

**Cultural and Community Development Grant Application
FY 2013-14**

Event/Project/Organization EL DORADO WESTERN RAILROAD
for which funds are requested:

Event/Project Location: SPTC CORRIDOR FROM SHINGLE SPRINGS - EL DORADO

Name of Organization: EL DORADO WESTERN RAILWAY FOUNDATION

Address of Organization: EL DORADO WESTERN RAILWAY FOUNDATION

PO BOX 3517

DIAMOND SPRINGS, CA 95619

Website: http://museum.edcgov.us/el-dorado-western-railroad

Name of Contact Person: DAVEY "DOC" WISER or MARY CORY

Telephone Number: (530) 644-1106 or (530) 621-5828

E-mail address: werwiser@att.com or mary.cory@edcgov.us

Total Amount Requested: \$5,000.00

C.A.O.
EL DORADO COUNTY
2013 AUG 16 PM 4:56

1. Briefly describe the event/project/organization for which funds are being requested:

The El Dorado Western Railroad (EDWR) is the Living History Program of the El Dorado County Historical Museum, giving the public the experience of riding on the former historic Placerville Branch of the Southern Pacific Railroad. The EDWR is 8 miles long, operating between Shingle Springs and Diamond Springs every Sunday and at special events with 35 volunteers managing operations under the authority of the El Dorado County Historical Museum Administrator. Currently operating 3 Fairmont A-Cars, each holds 6 adults and the operator, and on any given Sunday, two A-Cars transport the public on a 30-45 minute ride with historical narration about the history of County railroads. Donations given by riders are expended on upgrading the track and equipment. Our goal is to operate full size railroad equipment: an 18 ton Plymouth locomotive with a 40 ft 1940s-era flat car outfitted with benches and a historic Southern Pacific caboose. (See attachment 1)

2. If the request is being made for a specific event/project, please briefly describe the operating organization responsible for the event/project. If the organization has a managing board, please describe the make-up of the board and provide your board bylaws.

Requesting this grant is the El Dorado Western Railway Foundation (EDWRF), a non-profit 501c3 CA corporation in good standing, established in 1996 to develop and support, along with the El Dorado County Historical Museum, the re-creation of a historic El Dorado County railroad. The Board of Directors meets monthly and is the primary fund-raising organization for the EDWR, provides it financial support and fiscal oversight, applies for grants, puts on fund raisers, and looks for other ongoing financial support. The 2013-2014 officers are Edward Cunha-President, Mary Dakers-Vice President, Bill Rodgers-Treasurer and Mary Cory-Secretary. (See attachment 2)

3. Briefly describe how Cultural and Community Development funds will be used, if awarded, and what percentage of the funds will go towards the actual event/project:

100% of the funds requested will support two projects identified by the EDWRF as priorities. The first project is the purchase, delivery and installation of a 40 foot storage container to be placed close to operations in El Dorado. It will provide much needed and secure storage space for equipment, including the A-Cars, supplies and tools needed during regular operations. The second project is the repair and upgrade of the EDWRF's 18 ton Plymouth locomotive. The locomotive was donated 2 years ago with the plan to use it for regular and necessary Maintenance of Way work and to eventually haul passenger cars.

4. When will the event/project/program occur, and when would Cultural and Community Development funds be used, if awarded:

If the funds are awarded, the purchase of the container will occur within two months of receiving the funds and after the area along the tracks in the El Dorado townsite has been prepared for placement of the container. The work on the locomotive will commence as soon as the grant is awarded with completion anticipated in approximately six months, and consistent with the passenger hauling operations.

5. What is the target market for the advertising/promotional efforts and how will this target market be reached (please include details as to any advertising that will take place in and outside of the County and to encourage attendance from outside the County):

The target market is broad based, concentrating on the El Dorado County region, with the goal of expanding to the Sacramento and Northern California markets as the program develops. Now we publicize in the local newspaper "Mountain Democrat", the weekly newspaper "Windfall," distributing program flyers, the County Museum brochure and website, and a Facebook page and blog. (See attachment 3)

6. **The Board of Supervisors wishes to encourage tourism, agriculture, and economic development in the County by supporting promotional, community, and cultural activities through the use of Cultural and Community Development funds. Please describe how the event/organization will support tourism, agriculture, community spirit, culture, and/or economic development.**

Tourist railroad programs are tremendously popular with the public, and "rail fans" travel far and wide to participate in these programs. Our Railroad is situated between world class Railroad Museums in Sacramento and Carson City, and attracts visitors who are traveling along the Highway 50 corridor. The El Dorado Western Railroad brings visitors to the communities of El Dorado and Shingle Springs. The funds EDWRF is requesting this year, will be used to help the Railroad grow and become one of the premier tourist attractions in El Dorado County.

7. **What goal is expected to be achieved from the use of Cultural and Community Development funds, if awarded (please detail expected increased tourism, overnight stays, economic impact, etc.), and how will this be measured:**

EDWRF expects to achieve the goal of an operating locomotive that will put into use on the tracks, first in the community of El Dorado, and then on the tracks in Shingle Springs. The locomotive will be a great asset to the process of repairing and upgrading the track, speeding up the ability to initiate a "big train" program for the public. In addition, the container will provide much needed secure storage close to the location of Railroad operations, allowing volunteers to spend their time on restoring and repairing rail equipment and rolling stock. As a result of these improvements to the EDWR program, EDWRF will be able to increase its advertising and promotion to a broader audience.

8. **How will El Dorado County, as a sponsor of the event/project/organization, be recognized in promotional materials and at the event/project/organization:**

If the funds are awarded to EDWRF, the El Dorado County and the Cultural and Community Development Grant will be identified as a sponsor, if the funds are awarded, in printed and web-based material, and in the El Dorado Western Railway Foundation's quarterly newsletter, "The Dispatch."

9. **Please provide any information on sponsorships for this event/project/organization:**

The EDWR program has had the ongoing support of the EDWRF, the County Museum, the El Dorado Museums Foundation (a local nonprofit) and the Mountain Democrat newspaper by publishing the EDWR schedule weekly for free. The EDWR received a generous gift from an individual for the purchase of railroad ties, the A-Cars, and wheel repair on the 18 ton Plymouth locomotive. The El Dorado merchants have supported the EDWR with fund raisers and the Shingle Springs Depot owner has been unwavering in his support, as has other merchants in the Shingle Springs area. The public who turn out every Sunday has been most generous through their donations, which often time exceeds the suggested amount.

10. **If Cultural and Community Development funds are awarded, will the amount be matched (either full or partial) and by what organization:**

The merchants of the town of El Dorado have pledged a match of \$1,500 and the 18 ton Plymouth locomotive will be upgraded by in-kind services of a professional engine mechanic equalling \$2,250.

HISTORY OF EVENT/PROJECT/ORGANIZATON

1. How long has this event/project/organization been in operation:

The EDWR has been operating regularly since June, 2011 with rides offered to the public every Sunday since that time. Museum volunteers and staff were making plans for the Railroad many years earlier while other locations were investigated. With concerns about the preservation of the remaining historic former Southern Pacific Railroad Placerville Branch tracks, the concept of operating standard gauge railroad equipment on the existing tracks in the town of El Dorado was proposed. The El Dorado County Historical Museum's proposal to develop a Historical Railroad Park on the widest part of the right of way in El Dorado was approved by the El Dorado County Board of Supervisors in August, 2009. The El Dorado Western Railroad, the living history program of the El Dorado County Historical Museum was approved by the El Dorado County Board of Supervisors in December, 2010.

2. What is the overall attendance (past and future anticipated) of the event/project/organization:

Overall attendance on the El Dorado Western Railroad since June 2011 is approximately 7,000 riders. Currently we can carry about 12 people per ride, or approximately 60 people each Sunday. Additional special events, such as operating during the town of El Dorado's Memorial Day Weekend Craft Bazaar, a special Holiday event, and "charter" rides for reserved groups, have become very popular. We anticipate increasing our ridership with the increase in capacity by adding another Fairmont A-Car, currently a separate EDWR project. But a substantial increase in ridership will occur when the 18 ton Plymouth locomotive, flat car outfitted with benches and the restored Southern Pacific Railroad steel bodied caboose - the "Big Train" is put into operation.

3. Have Cultural and Community Development funds been received for this purpose in the past? If so, how much and when? If funds were received, please attach the Post-Event Report for this event.

The El Dorado Western Railroad has not received Cultural and Community Development funds in the past.

BUDGET FOR EVENT/PROJECT

Please detail all revenue and expenditures associated with the event/project/organization for which funds are being requested (only include guaranteed funds, i.e. not the funds being requested that have not yet been approved).

Additionally, for private non-profit and public organizations, please include a copy of the most recently completed financial statement and a copy of the budget for the event or organization for which funds are requested.

Revenue for event/project:

1. Funding/Contributions:

| Source | Amount |
|---|-------------------|
| Cultural and Community Development grant | \$5,000.00 |
| El Dorado town merchants | \$1,500.00 |
| Professional mechanic in-kind services (\$75 x 30hrs) | \$2,250.00 |
| | |
| Total: | \$8,750.00 |

2. Other earnings (i.e. admission fee, retained earnings, sale of products, etc.):

| Type | Amount |
|---------------|---------------|
| (N/A) | |
| | |
| | |
| | |
| Total: | |

3. **Describe any in-kind assistance/match funds you expect to receive from individuals, businesses or other community groups in support of this event/project/organization, which have not be confirmed or detailed above:**

The merchants of the town of El Dorado, through the work of Gail Hartwick, have pledged their financial support with a matching gift of \$1,500 if the Cultural and Community Development grant is awarded. Bob McCormack, a professional engine mechanic, has evaluated the 18 ton Plymouth locomotive and has made the commitment to repair and upgrade it to the standards required by railroad regulations.

Expenditures

1. **Expenditures for advertising and promotions (should correlate with revenue sources stated above):**

| <u>Expenditures</u> Item or service | <u>Cost:</u> | <u>Funded By</u> |
|--|--------------|------------------|
| 40 ft storage container purchase | \$3,150.00 | grant and match |
| container delivery | \$650.00 | match |
| container preparation and paint | \$200.00 | match |
| Locomotive air tanks | \$1,588.00 | grant |
| Locomotive fuel tank | \$518.00 | grant |
| Misc. plumbing, fittings brackets | \$394.00 | grant |
| | | |
| | | |
| Total: | \$ 6,500.00 | |

SUBMITTAL

The undersigned, declares that he/she has carefully examined the El Dorado County Cultural and Community Development Program and fully understands its contents and implications, and if funds are awarded the proposer will contract with the County to furnish the services as specified, in accordance with this grant application attached. The undersigned further attests that all information contained in this application is accurate to the best of his/her knowledge. Advertising funds are awarded, that proposer

Signature: 
Edward Cunha, President

Title: _____
El Dorado Western Railway Foundation

Applicant Organization: _____
August 16, 2013

Date: _____

Return Grant Application No Later than August 16, 2013 at 5:00 PM to:

**Chief Administrative Office
Attn: Economic Development
330 Fair Lane
Placerville, CA 95667**

Cultural and Community Development Grant Application
FY 2013-14

EL DORADO WESTERN RAILWAY FOUNDATION ATTACHMENTS

1. El Dorado Western Railroad 2013 Ride Schedule
2. El Dorado Western Railway Foundation Bylaws
3. Publicity printed weekly by the Mountain Democrat *at no charge*
4. Photograph of the 40 ft container located near the Shingle Springs Depot
5. Plymouth 18 ton Locomotive Upgrade plan
6. Current photograph of the Plymouth 18 ton Locomotive
7. El Dorado Western Railway Foundation Current Board of Directors

EL DORADO WESTERN RAILROAD

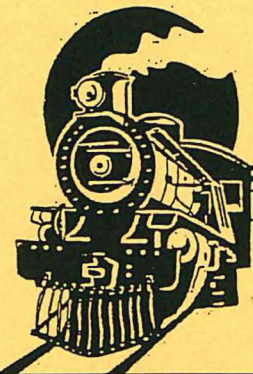

| Date | Location |
|--------------|---|
| May 5 | El Dorado Station |
| May 12 | Shingle Springs Depot |
| May 19 | El Dorado Station |
| May 26 | Shingle Springs Depot |
| June 2 | El Dorado Station |
| June 9 | Shingle Springs Depot |
| June 16 | El Dorado Station & join us at the County Fair! |
| June 23 | Shingle Springs Depot |
| June 30 | Shingle Springs Depot (Special Long Run) |
| July 7 | El Dorado Station |
| July 14 | Shingle Springs Depot |
| July 21 | El Dorado Station |
| July 28 | Shingle Springs Depot |
| August 4 | El Dorado Station |
| August 11 | Shingle Springs Depot |
| August 18 | El Dorado Station |
| August 25 | Shingle Springs Depot |
| September 1 | El Dorado Station |
| September 8 | Shingle Springs Depot |
| September 15 | El Dorado Station |
| September 22 | Shingle Springs Depot |
| September 29 | Shingle Springs Depot (Special Long Run) |
| October 6 | El Dorado Station |
| October 13 | Shingle Springs Depot |
| October 20 | El Dorado Station |
| October 27 | Shingle Springs Depot |
| November 3 | El Dorado Station |
| November 10 | Shingle Springs Depot |
| November 17 | El Dorado Station |
| November 24 | Shingle Springs Depot |
| December 1 | El Dorado Station |
| December 8 | Shingle Springs Depot |
| December 15 | El Dorado Station |
| December 22 | Shingle Springs Depot |
| December 29 | Shingle Springs Depot (Special Long Run) |

2013 Ride Schedule Every Sunday (Weather Permitting)

12:00pm to 4:00pm
Call (530) 409-8473 on Sunday for the time of the last ride's departure

**Now Arriving!
Every Sunday
in
El Dorado
or
Shingle
Springs!**

El Dorado County's own Railroad
Support the "oldest railroad line west of the Mississippi River" and ride a piece of history

Great family fun for all ages
\$5.00 donation for ages 9 and up
\$3.00 donation for ages 3 - 8

For information about tickets, reservations and charters, please call (530) 409-8473 and leave a message.

Regular Sunday rides are round trip, taking about 30—40 minutes. Special Two Hour round trip rides are scheduled on the 5th SUNDAY in March, June, September, and December. (Higher ticket prices will apply)

Boarding in El Dorado (6000 Oriental St.) Located next to the El Dorado Community Hall in the town of El Dorado. Take Hwy 49 to Pleasant Valley Road to the town of El Dorado. Then take Oriental Street (across from the Post Office) and keep left at the "Y" to the end of the road, then turn left to reach the station.
Boarding in Shingle Springs (4241 Mother Lode Dr.) Take Hwy 50 to Ponderosa Road exit and take Mother Lode Drive East (on the south side of Hwy 50) to the Historic Freight Depot on the left side of the road

Would you like to Volunteer? The El Dorado Western Railroad is operated and maintained by Museum Volunteers. Ask us about volunteering at a regular Sunday run, or contact Mary Cory, Museum Administrator, at mary.cory@edcgov.us or call her at 530.621.5828

The El Dorado Western Railroad is the Living History Program of the El Dorado County Historical Museum (<http://museum.edcgov.us>) Visit [facebook.com/ElDoradoWesternRailroad](https://www.facebook.com/ElDoradoWesternRailroad), eldoradowestern.blogspot.com, or call the County Museum at 530.621.5865 for more information

May 1, 2013

The EL DORADO WESTERN RAILROAD is the living history program of the El Dorado County Historical Museum, and through the efforts of volunteers, offers rides to the public on the historic PLACERVILLE BRANCH of what was the Southern Pacific Railroad line.

RAILROADS have been an important part of EL DORADO COUNTY'S HISTORY. After gold was discovered in 1848, the Gold Rush brought thousands of people to Northern California and with them, the idea of building a railroad from Sacramento to the Gold Fields. By 1853 the Sacramento Valley Railroad was begun, reaching Folsom in 1856. Due to competition among various investors to build the western portion of a future transcontinental railroad, the railroad line to Nevada did not go through Placerville to Carson City, but instead went through Auburn and the Donner Pass.

Because of heavy freight use along the Placerville-Lake Tahoe Wagon Road over Echo Summit, Placerville residents, pushed to continue the rail line from Folsom. With new investors, the track was laid to Latrobe in 1864 and to Shingle Springs by 1865. It took another 33 years to complete the rail line. The Placerville Depot opened for business in March, 1888 and the Placerville Branch carried lumber, fruit, butter and other produce, along with passengers bound for Sacramento, until 1986. After the Gold Rush lumber companies wanted to take advantage of the vast stands of timber in El Dorado County and two major logging railroads were built to transport logs and lumber. What eventually became the Michigan-California Lumber Company built an extensive network of narrow gauge rail to bring logs and rough cut lumber to the mills, including a cable which carried rail cars of lumber across the American River Canyon from the mill in Pino Grande on the north side of the river to the mill in Camino. Their standard gauge railroad, the Camino, Placerville & Lake Tahoe Railroad brought the milled lumber to Placerville to be loaded onto the Placerville Branch line. The Camino, Placerville & Lake Tahoe railroad right of way is now part of the El Dorado Trail.

Another logging railroad was put in by the Diamond & Caldor Lumber Company. Their network of narrow gauge rail was east of Grizzly Flat with a lumber mill in Caldor and another in Diamond Springs. The Shay Locomotive #4 currently undergoing restoration at the County Museum worked for

many years as a switch engine in the Diamond Springs Lumber Mill yard.

Southern Pacific's Placerville Branch had five combined freight and passenger depots, built to standard Southern Pacific Railroad designs: Latrobe, Shingle Springs, El Dorado, Diamond Springs and Placerville. The only existing structure is a portion of the Shingle Springs freight warehouse, built after a devastating 1896 fire burned the original 1865 station. The town of El Dorado now has a scaled version of the El Dorado Station through the generosity of volunteers and donors.

The boundaries of the EL DORADO WESTERN RAILROAD are Shingle Springs and Missouri Flat Road, with current operations at Shingle Springs and El Dorado. Plans to build the EL DORADO COUNTY HISTORICAL RAILROAD PARK facilities in El Dorado for exhibits and display track, a restoration shop and historical turntable are underway. Track repair is occurring on the 7.9 miles of track, and rolling stock is being restored. If you would like to VOLUNTEER, please contact one of the El Dorado Western Railroad volunteers or County Museum staff.

Additional historical information and photographs are at the El Dorado County Historical Museum, 104 Placerville Drive, Placerville, CA 95667. Information courtesy of Doug Noble's series of articles published in the Mountain Democrat Newspaper in 2007. Mary Cory, Museum Administrator, July 2012. Visit us at <http://museum.edcgov.us>



The El Dorado Depot, built in 1888, served both passengers and freight on the Placerville Branch of the Southern Pacific Railroad. This 1912 photo shows the school, now the El Dorado Community Hall on the left.

**BYLAWS OF THE
EL DORADO WESTERN RAILWAY FOUNDATION**

A California Nonprofit Public Benefit Corporation

Adopted: October 4, 1996
Amended: July 7, 2000
Amended: May 2, 2002
Amended Sept 28, 2005

ARTICLE I. NAME

The name of this Corporation is the El Dorado Western Railway Foundation, hereinafter called the "Foundation".

ARTICLE II. OFFICE

The principal office of the Foundation for its transaction of business is located at 104 Placerville Drive, Placerville, California 95667. The Board of Directors may change the principal office of the Foundation from one location to another in California. Any change of location of the principal office shall be noted by the Secretary in these Bylaws, but shall not be considered an amendment of these Bylaws.

ARTICLE III. PURPOSES AND LIMITATIONS

3.01. General Purposes:

The purpose of the Foundation shall be to restore and operate, between scenic locations within El Dorado County, California, historically accurate narrow gauge railroad equipment and related structures and artifacts, thereby promoting educational, scientific, and interpretative understanding of western logging history, and railroad technology and operation.

3.02. Limitations:

No substantial part of the activities of this Foundation shall consist of lobbying or propaganda, or otherwise attempting to influence legislation and the Foundation shall not participate or intervene in any political campaign (including the publishing or distribution of statements) on behalf of or in opposition to any candidate for public office.

ARTICLE IV. MEMBERS

4.01. Prohibition on Members:

The Foundation shall not have any members.

4.02. Effect of Prohibition:

Any action which would otherwise require approval by a majority of all members or approval by the members shall require only approval of the Board of Directors. All rights which would otherwise vest under law in the members shall vest in the Board of Directors.

ARTICLE V. DIRECTORS 5.01.

5.01. Number:

The Foundation shall have not less than 7 but no more than 15 Directors. The exact number of Directors shall be fixed from time to time, within the limits specified in this Section 5.01, by resolution of the Board of Directors. Collectively, the Directors shall be known as the Board of Directors.

5.02. Qualifications:

(a) Qualifications. Except as provided in this subsection, any person eighteen (18) years or older who supports the purposes of the Foundation is qualified to serve as a Director. However, only one member of a family may serve as a Director. For purposes of this subsection, a family includes spouses, children (including step or adopted children), grandchildren, parents, grandparents, aunts, uncles, and first cousins. (Amended July 7, 2000)

(b) Restriction on Interested Persons as Directors. No more than forty-nine percent (49 %) of the persons serving on the Board may be interested persons. An interested person is (1) any person compensated by the Foundation for services rendered to it within the previous twelve (12) months, whether as a full-time or part-time employee, independent contractor, or otherwise, excluding any reasonable compensation paid to a Director; and (2) any brother, sister, ancestor, descendant, spouse, brother-in-law, sister-in-law, son-in-law, daughter-in-law, mother-in-law, father-in-law of such person. However, any violation of the provisions of this subsection (b) of Section 5.02 shall not affect the validity or enforceability of any transaction entered into by the Foundation.

5.03. Terms of Office:

Each Director shall hold office three (3) years and until such Director's successor is elected and qualifies under Section 5.02 of these Bylaws. Directors shall be eligible for reelection without limitation to the number terms they may serve, provided they continue to meet the qualifications required by Section 5.02 of these Bylaws. One-third (1/3) of the Directors, or as near as may be, shall be elected each year. Initial terms of Directors shall be staggered, with the initial one, two, and three year terms determined by lot.

5.04. Election of Directors:

(a) Date of Election. An election of Directors shall occur each year, thirty (30) days prior to the end of the Foundation's current fiscal year, on a date established by the Board of Directors.

(b) Nominating Committee. At least sixty (60) days prior to the Date of Election set forth in subsection (a) of Section 5.04, the Board of Directors shall appoint a Nominating Committee composed of three (3) members. At least two (2) members of the Nominating Committee shall also be members of the Board of Directors.

(c) Report of Nominating Committee. At least thirty (30) days prior to the Date of Election set forth in subsection (a) of Section 5.04, the Nominating Committee shall submit its report to the Board of Directors and the nominees named in the report are deemed nominated. The Nominating Committee shall nominate at least enough nominees to fill the vacancies created by expiring terms, and may nominate more nominees.

(d) Election of Directors. On the Date of Election set forth in subsection (a) of Section 5.04, the Directors, including those Directors whose terms are expiring, shall elect the successor Directors. The candidates receiving the highest number of votes up to the number of Directors to be elected are elected.

5.05. Vacancies on Board of Directors:

(a) Vacancies. A vacancy or vacancies on the Board of Directors shall exist on the occurrence of the following:

- (1) the death or resignation of any Director;
- (2) the declaration by resolution of the Board of Directors of a vacancy in the office of a Director who has been declared of unsound mind by an order of court, convicted of a felony, or found by final order or judgment of any court to have breached a duty under Article 3 of Chapter 2 of the California Nonprofit Public Benefit Corporation Law;
- (3) the written vote of a majority of the Directors to remove any Director, with or without cause;
- (4) an increase of the authorized number of Directors; or

(5) the declaration by resolution of the Board of Directors of a vacancy in the office of a Director who has failed without excuse to attend three (3) meetings of the Board of Directors within a fiscal year.

(b) Filling Vacancies. Vacancies on the Board of Directors may be filled by a majority of the Directors then in office, whether or not less than a quorum, or by a sole remaining Director.

(c) Reduction of Number of Directors. No reduction of the authorized number of Directors shall have the effect of removing any Director before that Director's term of office expires at the end of the Foundation's current fiscal year.

5.06. Compensation:

The Directors shall serve without compensation except, as the Board in its discretion may determine by resolution, they shall be allowed and paid their actual and necessary expenses incurred in performing activities which further the purposes of the Foundation.

ARTICLE VI. BOARD OF DIRECTORS

6.01. Powers and Responsibilities:

(a) General Corporate Powers. Subject to the provisions and limitations of the California Nonprofit Public Benefit Corporation Law and any other applicable laws, and subject to any limitations of the Articles of Incorporation or these Bylaws, the Foundation's activities and affairs shall be managed, and all corporate powers shall be exercised, by or under the direction of the Board of Directors.

(b) Specific Powers and Responsibilities. Without prejudice to the general powers set forth in subsection (a) of Section 6.01, but subject to the same limitations, the Board of Directors shall have the power to:

- (1) Control and manage all equipment, supplies, assets, facilities, or all other property belonging to or entrusted to the Foundation;
- (2) Manage the financial affairs of the Foundation, including but not limited to the power to accept funds; and
- (3) To exercise any other authority determined to be in the best interest of the Foundation and authorized by the California Nonprofit Public Benefit Corporation law.

(c) The fiscal year shall commence on July 1 and end on June 30. The Board of Directors may change the fiscal year and such change shall be noted by the Secretary in these Bylaws, but shall not be considered an amendment of these Bylaws.

6.02. Meetings:

(a) Regular Meetings. Regular meetings of the Board of Directors shall occur, without call or notice, at 7:00 p.m., on the first Thursday of each month and held at the office of the Foundation as designated in Article II. **(Amended May 2, 2002)**

(b) Special Meeting. Special meetings of the Board may be called by the President, the Vice-President, the Secretary, or any two (2) Directors. Special meetings shall be held on four (4) days' notice by first class mail, postage prepaid, or on forty-eight (48) hours' notice delivered personally or by telephone, facsimile, or telegraph. The notice need not specify the purpose of the meeting. Notice of the special meeting need not be given to any Director who, either before or after the meeting, signs a waiver of notice or a written consent to holding the meeting or an approval of the minutes. All such waivers, consents, and approvals shall be filed with the Foundation's records or made a part of the minutes of the meetings. Notice of a meeting need not be given to any Director who attends the meeting and does not protest, before or at the commencement of the meeting, the lack of notice to him or her.

(c) Quorum. Five (5) Directors shall constitute a quorum for the transaction of business, except to adjourn. Every action taken or decision made by a majority of the Directors present at a duly held meeting at which a quorum is present shall be the act of the Board of the Directors. A meeting at which a quorum is initially present may continue to transact business, despite the withdrawal of Directors, if any action taken or decision made is approved by at least a majority of the required quorum for that meeting.

(d) Adjournment. A majority of the Directors present, whether or not a quorum is present, may adjourn any meeting to another time and place. Notice of the time and place of holding an adjourned meeting need not be given unless the original meeting is adjourned for more than 24 hours. If the original meeting is adjourned for more than 24 hours, notice must be given to the Directors who were not present at the time of the adjournment.

(e) Conduct of Meetings. The President or, in his or her absence, the Vice President shall preside at meetings of the Board of Directors. The Secretary of the Foundation or, in the Secretary's absence, any person appointed by the presiding officer shall act as Secretary of the Board. Members of the Board may participate in a meeting through use of conference telephone or similar communications equipment, so long as all members participating in such meeting can hear one another. Such participation shall constitute personal presence at the meeting

(f) Action Without Meeting. Any action required or permitted to be taken by the Board of Directors may be taken without a meeting, if all members of the Board of Directors individually or collectively consent in writing to such action. Such written consent or consents shall be filed with the minutes of the proceedings of the Board of Directors. Such action by written consent shall have the same force and effect as the unanimous vote of such Directors.

6.04. Committees:

The Board of Directors may, by resolution adopted by a majority of the number of Directors present at a meeting duly held at which a quorum is present, designate committees as needed to act for the Foundation to the extent specified in the resolution creating such committee(s). Each such committee shall consist of at least two (2) or more Directors and may include other persons who are not Directors. Appointments to committees shall be by the Board of Directors, and each committee shall serve at the pleasure of the Board. Committees shall have no legal authority to act for the Foundation, but shall report their findings and recommendations to the Board of Directors.

ARTICLE VII. OFFICERS

7.01. Number and Titles:

The officers of the Foundation shall be a President, a Vice-President, a Secretary, and a Chief Financial Officer.

7.02. Duties:

(a) President. The President is the general manager and chief executive officer of the Foundation and shall have broad discretion in supervising the Foundation's activities, affairs, and officers. The President is authorized to sign all contracts, notes, conveyances, and other papers, documents, and instruments in writing and in the name of the Foundation. The President shall preside at meetings the Board of Directors; and act as the Foundation's representative and liaison.

(b) Vice President. The Vice President shall assume the duties of the President in the President's absence or disability, and assist the President.

(c) Secretary. The Secretary shall record, maintain, and publish the minutes of all meetings of the Board of Directors, and shall keep and maintain those records and documents set forth in Section 8.01.

(d) Chief Financial Officer. The Chief Financial Officer is the chief financial officer of the Foundation, and is responsible for the receipt, maintenance, and disbursement of all funds and assets of the Foundation. The Chief Financial Officer shall maintain the financial records and records of all assets of the Foundation. In addition to any financial statements prepared at the request of the Board of Directors, the Treasurer shall prepare an annual report pursuant to Section 8.02 to be sent to the Directors of the Board as soon as reasonably practicable, but in no event no later than 120 days after the end of the Foundation's fiscal year.

7.03. Election, Term, Removal, and Vacancy:

(a) Election of Officers. Officers provided in this Article 8 shall be elected by the Board of Directors at the commencement of the fiscal year.

(b) Term of Office. Officers shall be elected for a term of one (1) year.

(c) Removal of Officers. Any officer elected or appointed by the Board of Directors may be removed from office at any time by the Board, with or without cause or prior notice.

(d) Vacancy of Office. A vacancy in an office caused by the death, resignation, or removal of the officer, shall be filled by appointment of the Board of Directors.

ARTICLE VIII. FOUNDATION RECORDS

8.01. Records and Documents:

(a) Minute Book. The Secretary shall keep or cause to be kept at the Foundation's principal office designated in Article II or such other place as the Board of Directors may direct, a book of minutes of all meetings, proceedings, and actions of the Board and of committees of the Board. The minutes of meetings shall include the time and place that the meeting was held, whether the meeting was regular or special, and, if special, how authorized, the notice given, the names of those present at Board and committee meetings.

(b) Records and Documents. Other than financial records, the Secretary shall maintain and keep, at the principal office set forth in Article II of these Bylaws or such other place as the Board of Directors may direct, all records concerning the Foundation, including a copy of the Articles of Incorporation and Bylaws, as amended to date.

8.02. Financial Records and Annual Report:

(a) Financial Records. The Chief Financial Officer shall keep and maintain, at the principal office set forth in Article II of these Bylaws or such other place as the Board of

Directors may direct, all financial records and records of Foundation assets.

(b) Annual Report. The Chief Financial Officer shall prepare an annual report which shall contain the following information, in appropriate detail, for the fiscal year:

- (1) The assets and liabilities of the Foundation as of the end of the fiscal year;
- (2) The principal changes in assets and liabilities;
- (3) The revenue or receipts of the Foundation; and
- (4) The expenses or disbursements of the Foundation.

The annual report shall be accompanied by any report of independent accountants, or, if there is no such report, a certificate by the Chief Financial Officer that the annual report was prepared without audit from the books and records of the Foundation.

ARTICLE IX. INDEMNIFICATION AND INSURANCE

9.01. Indemnification of Directors:

To the fullest extent permitted by law, this Foundation shall indemnify its directors, officers, employees, and other persons described in Section 5238(a) of the California Corporations Code, including persons formerly occupying any such position, against all expenses, judgments, fines, settlements, and other amounts actually and reasonably incurred by them in connection with any "proceeding," as that term is used in that Section 5238(a), and including an action by or in the right of the Foundation, by reason of the fact that the person is or was a person described in that Section 5238(a). "Expenses," as used in this Section 9.01, shall have the same meaning as in Section 5238(a) of the California Corporations Code.

9.02. Approval of Indemnity:

On written request to the Board of Directors by any person seeking indemnification under Section 5238(b) or Section 5238(c) of the California Corporations Code, the Board shall promptly determine under Section 5238(e) of the California Corporations Code whether the applicable standard of conduct set forth in Section 5238(b) or 5238(c) has been met and, if so, the Board shall authorize indemnification.

9.03. Advancement of Expenses:

To the fullest extent permitted by law and except as otherwise determined by the Board of Directors in a specific instance, expenses incurred by a person seeking indemnification under Sections 9.01 and 9.02 of these Bylaws in defending any proceeding covered by those Sections shall be advanced by the Foundation before final disposition of the proceeding, on receipt by the Foundation of an undertaking by or on behalf of that person that the advance will be repaid unless it is ultimately determined that the person is entitled to be indemnified by the Foundation for those expenses.

9.04. Insurance:

The Foundation shall have the right to purchase and maintain insurance to the fullest extent permitted by law on behalf of its officers, directors, employees, and other agents, against any liability asserted against or incurred by any officer, director, employee, or agent in such capacity or arising out of the officer's, director's, or agent's status as such.

ARTICLE X. AMENDMENTS

These Bylaws may be amended or repealed by a majority of the Directors present at a meeting duly held at which a quorum is present.

CERTIFICATE OF SECRETARY

I certify that I am the duly elected and acting Secretary of the EL DORADO WESTERN RAILWAY FOUNDATION, a California nonprofit public benefit corporation, that the above Bylaws, consisting of ten (10) pages, are the Bylaws of this Foundation as adopted by the Board of Directors on October 4, 1996, and that they have not been amended or modified since that date.

Executed on October 4, 1996, at Diamond Springs, California.

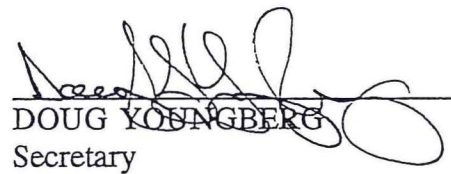

DOUG YOUNGBERG
Secretary

EL DORADO WESTERN RAILWAY FOUNDATION
AMENDMENT OF THE OCTOBER 4, 1996 BYLAWS

Pursuant to Article 10 of the Bylaws of the El Dorado Western Railway Foundation, Section 5150 of the California Corporations Code, Section 5342 of the California Non-Profit Public Benefit Corporation Law, and pursuant to a Board of Directors Meeting held on July 7, 2005, wherein it was proposed that the Bylaws of this Corporation be amended to allow associate members to become an active part of the El Dorado Western Railway Foundation.

ARTICLE IV: rticle IV, Section 4.01 of the Bylaws of the Foundation is deleted in its entirety and is amended to read as follows:

Article IV. MEMBERS.

- 4.01 Members. Any person interested in the purposes and limitations of the Foundation as set forth in Article III of the Bylaws shall be eligible for an associate membership in the Foundation upon the receipt of the required dues.
- 4.03 The term "members" as set forth in these Bylaws is not members within the meaning of Section 5056 of the California Corporations Code.
- 4.04 The annual dues in the amount established by the Board of Directors shall be due in January of each calendar year and payable in advance. The membership secretary shall notify members whose dues are not paid by February 15th, and those whose dues are not paid within 30 days thereafter shall be dropped from membership. New members may pay any time during the calendar year. There will be no proration of dues.

CERTIFICATION: This is to certify that the foregoing is a true and correct copy of the Amendment to the Bylaws of the Foundation named and entitled thereto and that such amended Bylaws were duly adopted by the members of said Foundation and certified by its secretary on the date set forth below.

DATE: Sept 28, 2005

Secretary

well oiled, it can fall apart. This was one of the most important things taught. We need each other, and we can't truly be leaders if we don't care about each other and work at a better life for us all.

Admittedly, I think part of the reason the class is so successful after seven years is because the people who are working

to get underway, so if you're interested, contact Laurel Brent-Bumb at 530-621-5885 or chamber@eldoradocounty.org. For more information, visit eldoradocounty.org/leadershipeldorado.html.

Patrick Ibarra is the managing editor of the Mountain Democrat.

Mt. Dem
August 14, 2013

ALL ABOARD!

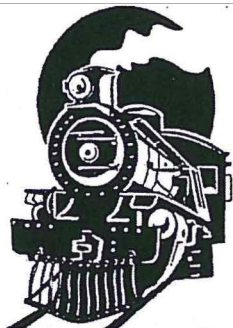

El Dorado Western Railroad

2013 Ride Schedule

**Now Arriving
Every Sunday!**
(Weather Permitting)

12:00pm to 4:00pm

**1st & 3rd Sundays
boarding in El Dorado**
6000 Oriental St. at the El Dorado Station
*(next to the El Dorado Community Hall
in the town of El Dorado)*

**2nd & 4th Sunday
boarding in Shingle Springs**
4241 Mother Lode Drive
(next to the Shingle Springs Depot)

| Date | Location |
|--------------|---|
| August 18 | El Dorado Station |
| August 25 | Shingle Springs Depot |
| September 1 | El Dorado Station |
| September 8 | Shingle Springs Depot |
| September 15 | El Dorado Station |
| September 22 | Shingle Springs Depot |
| September 29 | Shingle Springs Depot (Special Long Run) |
| October 6 | El Dorado Station |
| October 13 | Shingle Springs Depot |
| October 20 | El Dorado Station |
| October 27 | Shingle Springs Depot |
| November 3 | El Dorado Station |
| November 10 | Shingle Springs Depot |
| November 17 | El Dorado Station |
| November 24 | Shingle Springs Depot |
| December 1 | El Dorado Station |
| December 8 | Shingle Springs Depot |
| December 15 | El Dorado Station |
| December 22 | Shingle Springs Depot |
| December 29 | Shingle Springs Depot (Special Long Run) |

GREAT FAMILY FUN FOR ALL AGES

\$5.00 donation for ages 9 and up ~ \$3.00 donation for ages 3-8

El Dorado County's own Railroad

Rides are round trips, taking about 30-40 minutes.

Groups of 15 or more may call 530.626.8688 to make reservations.

Longer rides will be scheduled as part of the 5th Sunday Special Events in March, June, September, and December.

YS

n

umber® Pentagon
Ground Blind

03451493

TRUE TIMBER
CAMO



This is a view of the 40 ft secure storage container located near the Shingle Springs Depot. The EDWRF is requesting funds for a similar container to be placed near operations in El Dorado.

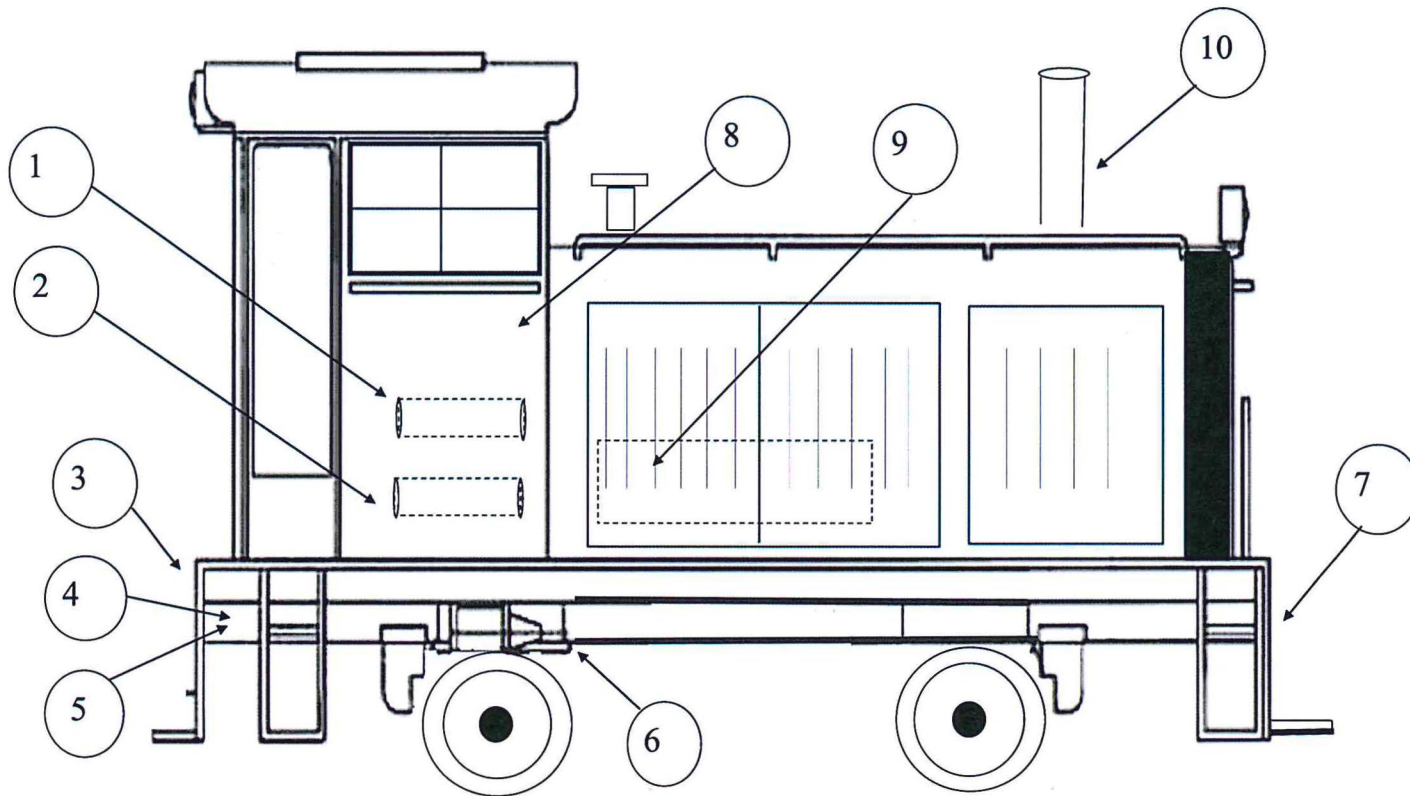

- ① REMOVE FUEL TANK FROM INSIDE OF CAB.
- ② REMOVE AIR TANK FROM INSIDE OF CAB.
- ③ INSTALL NEW 1 1/4 INCH AIR LINE FOR TRAIN BRAKES.
- ④ INSTALL NEW AIR TANK AT LOCATION SHOWN
- ⑤ INSTALL NEW AIR TANK AT LOCATION SHOWN (OPPOSITE SIDE)
- ⑥ SERVICE LOCOMOTIVE BRAKE CYLINDERS.
- ⑦ INSTALL NEW 1 1/4 INCH AIR LINE FOR TRAIN BRAKES.
- ⑧ INSTALL NEW TRAIN AIR BRAKE SYSTEM.
- ⑨ INSTALL NEW UNDER HOOD FUEL TANK
- ⑩ INSTALL NEW EXHAUST SPARK ARRESTER

PAINT LOCOMOTIVE WITH COLOR TO BE DETERMINED BY EL DORADO WESTERN RAILROAD.

WORK TO BE CONDUCTED IN ACCORDANCE WITH RECOGNIZED CODES AND STANDARDS AND APPLICABLE STATE AND FEDERAL REGULATION.

**El Dorado Western
Railroad**

PROJECT NO. 2013
 DRAWN: 2013
 DRAWN BY: EW CUNHA
 CHECKED BY:
 FILE NAME: Plymouth

**Plymouth 18 ton Locomotive
Upgrade**

NOT TO SCALE

PLATE

1



18 ton Plymouth Locomotive

**EL DORADO WESTERN RAILWAY FOUNDATION
BOARD OF DIRECTORS
AUGUST 2013**

| Expires June 30, 2014 | Expires June 30, 2015 | Expires June 30, 2016 |
|--|--|---|
| Keith Berry 6700 Crystal Blvd El Dorado, CA 95623 642-0742(h) 558-5168© eldorberry@comcast.net | Bob McCormack 6220 North St El Dorado, CA 95623 306-7775 robmcc8321@yahoo.com | Ed Cunha (President) 3465 Wedge Hill Rd Placerville, CA 95667 622-5206 cunha2@comcast.net |
| Mark Bruto 4731 Greenhills Rd Placerville, CA 95667 621-1458 burnzoil@yahoo.com | Kris Payne PO 609 Diamond Springs, CA 95619 642-5926 (w) 626-6474 (h) kris.payne@edcgov.us | Eric Stohl 4438 Park Woods Dr. Pollock Pines, CA 95726 (916) 635-7801 estohl@comcast.net |
| Steve Karoly PO Box 1007 Diamond Springs, CA 95619 622-1280 steve@seabeecook.com | | Mary Dakers (Vice President) 5385 Victory Mine Rd Placerville, CA 95667 626-8688, 409-8473 (cell) |
| Davey "Doc" Wisner PO Box 329 Placerville, CA 95667 644-1106(h) 957-4758(c) werwiser@att.com | | |

| | |
|--|--|
| Mary Cory, Museum Administrator (Secretary) And <i>ex officio</i> board member El Dorado County Museum 104 Placerville Dr. Placerville, CA 95667 621-5828 (w), 647-2677 (h) mary.cory@edcgov.us , museum@edcgov.us | Bill Rodgers (Treasurer) 2154 Old Vineyard Ln. Placerville, CA 95667 622-7415 rrogers@innercite.com |
|--|--|

EDWRF Mailing Address

PO Box 3517

Diamond Springs, CA 95619

Website: <http://museum.edcgov.us/el-dorado-western-railroad>

Blog: www.eldoradowestern.blogspot.com

Facebook page: www.facebook.com/eldoradowesternrailroad

Pie Schedule for 2013-2014

| | | | |
|--------|--------------------------|---------|---------------|
| Sept 3 | Ed Cunha | March 4 | Steve Karoly |
| Oct 7 | Keith Berry | April 1 | Bob McCormick |
| Nov 5 | Mary Dakers | May 6 | Kris Payne |
| Dec | Annual Meeting & Potluck | June 3 | Mark Bruto |
| Jan 7 | Eric Stohl | July 1 | Mary Cory |
| Feb 4 | Davey "doc" Wisner | Aug 5 | Open |

It is the mission of the El Dorado Western Railway Foundation, in association with the El Dorado County Historical Museum, to create a quality logging railroad facility that is historically accurate, promotes education about El Dorado County logging, and provides logging railroad re-enactment to the mutual satisfaction and benefit of the community.