



**COUNTY OF EL DORADO, CALIFORNIA  
CHIEF ADMINISTRATIVE OFFICE  
FACILITIES DIVISION**

**CONTRACT DOCUMENTS**

INCLUDING

**NOTICE TO BIDDERS,  
PROPOSAL, CONTRACT,  
AND CONDITIONS OF THE CONTRACT**

FOR

**COUNTY OF EL DORADO  
SOUTH LAKE TAHOE (SLT)  
HEALTH & HUMAN SERVICES AGENCY (HHSA)  
TENANT IMPROVEMENT PROJECT**

**BID #19-968-041**

**BIDS MUST BE RECEIVED BY:  
3:00 p.m. on March 20, 2019  
Procurement & Contracts  
330 Fair Lane, Placerville, CA 95667**

**COUNTY OF EL DORADO, STATE OF CALIFORNIA  
CHIEF ADMINISTRATIVE OFFICE  
FACILITIES DIVISION**

**COUNTY OF EL DORADO  
SOUTH LAKE TAHOE (SLT)  
HEALTH & HUMAN SERVICES AGENCY (HHSA)  
TENANT IMPROVEMENT PROJECT**

**BID #19-968-041**

**TABLE OF CONTENTS**

<b>NOTICE TO BIDDERS</b>	<b>N-1</b>
<b>INSTRUCTIONS TO BIDDERS</b>	<b>I-1</b>
<b>PROPOSAL</b>	<b>P-1</b>
<b>DRAFT AGREEMENT FOR CONSTRUCTION SERVICES</b>	<b>C-1</b>
<b>CONTRACTOR'S GUARANTEE</b>	<b>NO PAGE #</b>
<b>PAYMENT BOND</b>	<b>NO PAGE #</b>
<b>PERFORMANCE BOND</b>	<b>NO PAGE #</b>
<b>CALIFORNIA FORM 590 - 2015 WITHHOLDING CERTIFICATE</b>	<b>NO PAGE #</b>
<b>COUNTY OF EL DORADO PAYEE DATA RECORD FORM</b>	<b>NO PAGE #</b>
<b>CERTIFICATE OF INSURANCE FORM</b>	<b>NO PAGE #</b>
<b>CONDITIONS OF THE CONTRACT</b>	<b>CC-1</b>
<b>PLANS &amp; SPECIFICATIONS - SEPARATE</b>	
<b>TENANT IMPROVEMENT PLANS</b>	
<b>TENANT IMPROVEMENT SPECIFICATION</b>	
<b>ASBESTOS &amp; LEAD REPORT</b>	

**COUNTY OF EL DORADO, CALIFORNIA  
CHIEF ADMINISTRATIVE OFFICE  
FACILITIES DIVISION**

**NOTICE TO BIDDERS**

**NOTICE IS HEREBY GIVEN** by the County of El Dorado, State of California, that sealed bids for work in accordance with the Project Plans (Plans) and Bid Documents designated:

**COUNTY OF EL DORADO  
SOUTH LAKE TAHOE (SLT)  
HEALTH & HUMAN SERVICES AGENCY (HHSA)  
TENANT IMPROVEMENT PROJECT  
BID #19-968-041**

will be received by the Chief Administrative Office, Procurement & Contracts Division, at **330 FAIR LANE, PLACERVILLE, CALIFORNIA**, until **3:00 p.m. on MARCH 20, 2019**, at which time and place bids will be publicly opened and read by the Chief Administrative Office, Procurement & Contracts Division.

No Bid may be withdrawn after the time established for receiving bids or before the award and execution of the Contract, unless the award is delayed for a period exceeding sixty (60) calendar days. Bids shall be executed in accordance with the instructions given and on the forms provided in the Bid Documents furnished by the County of El Dorado, Chief Administrative Office, Procurement & Contracts Division at the mandatory Pre-Bid Meeting. All bids must be clearly marked on the envelope:

**“COUNTY OF EL DORADO  
SOUTH LAKE TAHOE  
HEALTH & HUMAN SERVICES AGENCY (HHSA)  
TENANT IMPROVEMENT PROJECT”  
BID #19-968-041  
TO BE OPENED AT 3:00 P.M. ON MARCH 20, 2019**

**LOCATION/DESCRIPTION OF THE WORK:** The project is located at 3368 Sandy Way, South Lake Tahoe, California in El Dorado County. The Work to be done as shown on the Plans, generally consists of, but is not limited to:

- A. The furnishing of all labor, materials and equipment for construction of the South Lake Tahoe (SLT) Health & Human Services (HHSA) Tenant Improvement Project as shown or required per the Bid Documents. Bids are required for the entire work described herein.
- B. The contract time shall be **ninety six (96) calendar days commencing from the date shown on the Notice to Proceed.**
- C. For bonding purposes the estimated project cost is **approximately \$800,000.**
- D. A Pre-Bid / Site Visit Meeting is scheduled for this project on **FEBRUARY 20, 2019 at 1:00 P.M. at 3368 SANDY WAY SOUTH LAKE TAHOE, CALIFORNIA. ATTENDANCE AT THE PRE-BID MEETING IS MANDATORY AND ONLY THE BIDS OF FIRMS WITH REPRESENTATIVES IN ATTENDANCE WILL BE CONSIDERED FOR EVALUATION AND AWARD. ANY BIDDER REPRESENTATIVE WHO HAS NOT SIGNED THE SIGN-IN SHEET BY 1:05 P.M. WILL NOT BE ABLE TO PARTICIPATE IN THE JOB WALK AND WILL NOT BE ABLE TO SUBMIT A BID.** In order to limit the disruption to the conduct of business, the meeting date listed will be the only opportunity for bidders to visit the site. The Bidder's representative will be required to sign an attendance sheet and provide the name of the firm being represented. The County will post on the Procurement & Contract's website such Addenda as the County in its discretion considers necessary in response to questions arising and information presented at the Pre-Bid / Site Visit Meeting. Oral statements shall not be relied

upon and will not be binding or legally effective. Addenda issued as a result of the Pre-Bid / Site Visit Meeting shall constitute the sole and exclusive record and statement of the results of the Pre-Bid / Site Visit Meeting.

**QUESTIONS:** Questions will be accepted in writing only, by email or in hard copy, until **5:00 p.m. on MARCH 10, 2019**. Questions can be emailed to: [michele.weimer@edcgov.us](mailto:michele.weimer@edcgov.us) or delivered to: County of El Dorado, Procurement & Contracts, 330 Fair Lane, Placerville, CA 95667. Answers to questions deemed relevant and appropriate will be emailed to all eligible bidders by **5:00 p.m. on MARCH 14, 2019**.

**OBTAINING OR INSPECTING BID DOCUMENTS:** The Bid Documents including Plans may be examined:

- Online at <http://edcapps.edcgov.us/contracts/invite.asp>
- At the County of El Dorado, Chief Administrative Office, Procurement & Contract Division located at 330 Fair Lane, Placerville, California, 95667
- Distributed at Pre-Bid Meeting on February 20, 2019

**ONLY BID DOCUMENTS DISTRIBUTED AT THE MANDATORY PRE-BID MEETING  
ON FEBRUARY 20, 2019 WILL BE ACCEPTABLE FOR BID SUBMITTAL.**

**CONTRACTORS LICENSE CLASSIFICATION:** Bidders must be properly licensed to perform the Work pursuant to the Contractors' State License Law (Business and Professions Code Section 7000 et seq.) and must possess a **Class B – General Building Contractor License** at the time bids are submitted, and must maintain a valid license and certification through completion and acceptance of the Work, including the guarantee and acceptance period. Failure of the successful Bidder to obtain proper adequate licensing at the time of contract award shall constitute a failure to execute the Contract and shall result in the forfeiture of the Bidder's security, and may result in legal penalties.

**BUSINESS LICENSE:** The County Business License Ordinance provides that it is unlawful for any person to furnish supplies or services, or transact any kind of business in the unincorporated territory of El Dorado County without possessing a County business license unless exempt under County Ordinance Code Section 5.08.070. The Bidder to whom an award is made shall comply with all of the requirements of the County Business License Ordinance, where applicable, prior to beginning work under this Contract and at all times during the term of this Contract.

**REQUIRED LISTING OF PROPOSED SUBCONTRACTORS:** Each Proposal shall have listed therein the name, contractor's license number, DIR number, and address of each subcontractor, to whom the Bidder proposes to subcontract portions of the work in an amount in excess of 1/2 of one percent of its total bid in accordance with the Subletting and Subcontracting Fair Practices Act, commencing with Section 4100 of the Public Contract Code. The Bidder shall also describe in the Subcontractor Listing the work to be performed by each subcontractor listed. The work to be performed by the subcontractor shall be shown by listing the description of the work, and portion of the work to be performed by the subcontractor in the form of a percentage calculated by dividing the work to be performed by the subcontractor by the lump sum bid price. At the time the bids are submitted all listed subcontractors shall be properly licensed to perform their designated portion of the work. The Bidder's attention is invited to other provisions of the Act related to the imposition of penalties for a failure to observe its provisions by using unauthorized subcontractors or by making unauthorized substitutions.

An inadvertent error in listing the California contractor license number on the Subcontractor List will not be grounds for filing a bid protest or grounds for considering the bid non-responsive if the Bidder submits the corrected contractor's license number via email to [michele.weimer@edcgov.us](mailto:michele.weimer@edcgov.us) within 24 hours after the bid opening, provided the corrected contractor's license number corresponds to the submitted name and location for that subcontractor.

**CONTRACTOR REGISTRATION:** No contractor or subcontractor may be listed on a bid proposal for public works project (submitted on or after March 1, 2015) or awarded a contract for a public works project (awarded on or after April 1, 2015) unless registered with the Department of Industrial Relations pursuant to Labor Code Sections 1771.1(a), 1725.5. An inadvertent error in listing a subcontractor who is not registered pursuant to Section 1725.5 in a bid proposal shall not be grounds for filing a bid protest or grounds for considering the bid nonresponsive if the requirements of Labor Code section 1771.1 are met.

**NONDISCRIMINATION:** Attention is directed to the following Notice that is required by Chapter 5 of Division 4 of Title 2, California Code of Regulations.

**NOTICE OF REQUIREMENT FOR NONDISCRIMINATION PROGRAM  
(GOVERNMENT CODE SECTION 12990)**

**PREVAILING WAGE REQUIREMENTS:** In accordance with the provisions of California Labor Code Sections 1770 et seq., the general prevailing rate of wages in the county in which the Work is to be done has been determined by the Director of the California Department of Industrial Relations. These wage rates appear in the California Department of Transportation publication entitled General Prevailing Wage Rates. Interested parties can obtain the current wage information by submitting their requests to the Department of Industrial Relations, Division of Labor Statistics and Research, P.O. Box 420603, San Francisco CA 94142-0603, Telephone (415) 703-4708 or by referring to the website at <http://www.dir.ca.gov/dlsr/PWD>. The rates at the time of the bid advertisement date of a project will remain in effect for the life of the project in accordance with the California Code of Regulations, as modified and effective January 27, 1997.

Copies of the general prevailing rate of wages in the county in which the Work is to be done are also on file at the Chief Administrative Office, Facilities Division, and are available upon request.

In accordance with the provisions of Labor Code 1810, eight (8) hours of labor shall constitute a legal day's work upon all work done hereunder, and Contractor and any subcontractor employed under this Contract shall conform to and be bound by the provisions of Labor Code Sections 1810 through 1815.

This Project is subject to the requirements of Title 8, Chapter 8, Subchapter 4.5 of the California Code of Regulations including the obligation to furnish certified payroll records directly to the Compliance Monitoring Unit under the Labor Commissioner within the Department of Industrial Relations Division of Labor Standards Enforcement in accordant with Section 16461.

**BID SECURITY:** A bid security shall be provided with each bid. Bid security shall be in an amount of not less than ten percent (10%) of the total amount bid for the Work and shall be cash, a certified check or cashier's check drawn to the order of the County of El Dorado or a Bidder's Bond executed by a surety satisfactory to the County of El Dorado on the **form(s) provided in the Proposal Section of these Bid Documents (do not detach the form)**.

**AWARD OF CONTRACT:** The County of El Dorado reserves the right after opening bids to reject any or all bids, to waive any irregularity in a bid, or to make award to the lowest responsive, responsible Bidder and reject all other bids, as it may best serve the interests of the County. The Purchasing Agent will recommend the bids for award by the Board of Supervisors.

As a condition of award, the successful Bidder will be required to submit bonds and evidence of insurance prior to execution of the Agreement by the County. Failure to meet this requirement shall constitute abandonment of the Bid by the Bidder and forfeiture of the Bidder's security. Award will then be made to the next lowest responsible Bidder.

**BIDDERS PROTEST PROCEDURES:**

Upon completion of the bid evaluation, the County of El Dorado Chief Administrative Office, Procurement & Contracts Division, will notify all bidders in writing of its recommendation including for award or rejection of bids, and the date and time on which the recommendation for award will be considered and acted upon by the Board of Supervisors ("Notice of Intent to Award"). All bidders may attend the Board of Supervisors meeting, address the Board, and be heard.

**Within 5 working days** from the date of the Notice of Intent to Award, the Bidder protesting the recommendation for award must submit a formal written protest to the Procurement & Contracts Division, stating in detail the basis and reason for the protest. The Bidder must provide facts to support the protest including any evidence Bidder wishes to be considered together with the law, rule, regulation, or criteria on which the protest is based. The Bidder may attend the Board of Supervisors meeting at which the recommendation and bid protest will be considered. If the Bidder is not in attendance at that time, the bid protest may be dismissed by the Board of Supervisors without further consideration of the merits and the decision of the Board of Supervisors on the bid protest will be final.

**PAYMENTS:** Attention is directed to Article 6.2 – APPLICATIONS FOR PAYMENT of the Conditions of the Contract.

**RETAINAGE FROM PAYMENTS:** The Contractor may elect to receive one hundred percent (100%) of payments due under the Contract from time to time, without retention of any portion of the payment by the County, by depositing securities of equivalent value with the County in accordance with the provisions of Section 22300 of the Public Contract Code.

Securities eligible for deposit hereunder shall be limited to those listed in Section 16430 of the Government Code, or bank or savings and loan certificates of deposit.

**PROJECT ADMINISTRATION:** All communications relative to the Bid Documents and Plans shall be directed to Michele Weimer in the County of El Dorado Chief Administrative Office, Procurement & Contracts Division, 330 Fair Lane, Placerville, CA 95667, telephone: (530) 621-5670 or email [michele.weimer@edcgov.us](mailto:michele.weimer@edcgov.us). No oral responses to any questions concerning the content of the Plans and Contract Documents will be given. All responses will be in the form of written Addenda to the Plans and/or Bid Documents, or written responses to bidder's inquiries.

**BY ORDER OF** the Board of Supervisors, County of El Dorado, State of California. Authorized by the Board of Supervisors on January 29, 2019 at Placerville, California.

Dated: \_\_\_\_\_

By: \_\_\_\_\_

Chair, Board of Supervisors

ATTEST:

James S. Mitrisin  
Clerk of the Board of Supervisors

By: \_\_\_\_\_  
Deputy Clerk

Dated: \_\_\_\_\_

**\* END OF NOTICE TO BIDDERS \***

**THESE INSTRUCTIONS SUPPLEMENT THE NOTICE TO BIDDERS, PROPOSAL,  
DRAFT AGREEMENT, AND CONDITIONS OF THE CONTRACT**

**COUNTY OF EL DOREADO  
SOUTH LAKE TAHOE (SLT)  
HEALTH & HUMAN SERVICES AGENCY (HHS)  
TENANT IMPROVEMENT PROJECT**

**BID #19-968-041**

**INSTRUCTIONS TO BIDDERS**

1. The County of El Dorado will receive sealed bids from Bidders as stipulated in the Notice to Bidders.
2. The County of El Dorado reserves the right after opening bids to reject any or all bids, to waive any irregularity in a bid, or to make award to the lowest responsive, responsible Bidder and reject all other bids, as it may best serve the interests of the County.
3. Bidders must submit bids only on forms provided in the Bid Documents provided at the Mandatory Pre-Bid Meeting, and shall be accompanied by all documents and information required to be submitted by these Instructions to Bidders, the Notice to Bidders, and by law. Bids not submitted on the required forms shall be deemed nonresponsive and shall not be considered. The Proposal is attached together with the Notice to Bidders, Instructions to Bidders, Agreement, and related documents. A Proposal shall be deemed "Non-Responsive" if the Bid is submitted without the entire package provided at the Mandatory Pre-Bid Meeting.
4. Bidders must submit Non-Collusion Affidavit form with their bids. Bids submitted without the affidavit will be deemed nonresponsive and will not be considered.
5. Bidders must submit signed Confidentiality of Information provided form with their bid. Bids submitted without the affidavit will be deemed nonresponsive and will not be considered.
6. Bidders must supply all information required by Bid Documents and specifications. Bids must be full and complete. The County reserves the right at its sole discretion to reject any bid as nonresponsive as a result of any error or omission in the bid.
7. Bidders may not modify Proposal Document or qualify their bids.
8. Submission of a bid signifies that the Bidder has done a careful examination of the Bid Documents and has a complete understanding of the nature, extent and location of Work to be performed. Bidder must complete the tasks listed below in subsections "a" and "b" as a condition to bidding, and submission of bid shall constitute the Bidder's express representation to the County that Bidder has fully completed the following:
  - a. Bidder has attended the mandatory pre-bid meeting and has examined thoroughly and understands the nature and extent of the Bid Documents, Work, Site, locality, actual conditions, as-built conditions, and all local conditions and federal, state and local laws and regulations that in any manner may affect cost, progress, performance or furnishing of Work or which relate to any aspect of the means, methods, techniques, sequences or procedures of construction to be employed by Bidder and safety precautions and programs incident thereto.

- b. Bidder has given the County representative during the bid period prompt written notice of all conflicts, errors, ambiguities or discrepancies that it has discovered in or among the Bid Documents and as built and actual conditions and the written resolution thereof by County is acceptable to Bidder.
9. **Substitutions:** If the Bidder lists a manufacturer in its Proposal that is a substitute (i.e. "or equal"), such listing shall be considered a substitution request by the Bidder. If the Bidder is the apparent low Bidder, the Bidder shall, within two (2) business days following the bid opening, submit data substantiating the request for the substitution with the "or equal" item. Failure to submit such substantiating data within two (2) business days following the bid opening may result in the County deeming the apparent low Bidder non-responsive. If no substitute manufacturer is listed in its Proposal, the Bidder shall supply all materials as specified in the Technical Specifications. NO substitution request will be considered after bid opening.
10. The following documents are to be executed and submitted by the apparent low Bidder after bids have been opened and duly inspected, and the County transmits the Notice of Award package to the successful Bidder. Failure to properly and timely submit these documents entitles the County to determine that the Bidder has abandoned the contract, and the bidder's security shall be forfeited to County.

Submit the following documents to Michele Weimer, Chief Administrative Office, Procurement & Contracts Division, 330 Fair Lane, Placerville, CA 95667 by 5:00 p.m. of the **TENTH** calendar day, following the date of the NOTICE OF AWARD OF CONTRACT letter. Execution of Contracts by the County depends upon approval of Insurance Certificates and Bonds, and associated contract documents.

- i. Contracts: The successful Bidder shall execute and submit the Agreements for the work associated with the Proposal Lump Sum Bid Price Schedule (See Draft Agreement). Submit two (2) originals of Agreement, each bearing an original signature.
- ii. County of El Dorado Performance Bond: To be executed by successful Bidder and surety each with notary acknowledgement.
- iii. County of El Dorado Payment Bond: To be executed by successful Bidder and surety each with notary acknowledgement.
- iv. Insurance certificates required by Contract Conditions and Article 8.
- v. California Form 590 – Withholding Exemption and County Payee Data Record Form.

**\* END OF INSTRUCTIONS TO BIDDERS \***



**THE USE OF PENCIL OR CORRECTION FLUID OR TAPE IS NOT ACCEPTABLE.  
BID DOCUMENTS COMPLETED IN PENCIL OR CONTAINING THE USE OF CORRECTION FLUID OR  
TAPE WILL BE REJECTED.**

**ALL CHANGES MUST BE LINED OUT AND CORRECTIONS INSERTED ADJACENT TO THE CHANGE AND  
INITIALED BY THE BIDDER'S AUTHORIZED REPRESENTATIVE**

**PROPOSAL**

**DO NOT DETACH ANY PAGES FROM THIS BOUND BID DOCUMENT.**

**TO: CHIEF ADMINISTRATIVE OFFICE, PROCUREMENT & CONTRACTS DIVISION  
COUNTY OF EL DORADO, STATE OF CALIFORNIA**

for the construction of

**SOUTH LAKE TAHOE (SLT)  
HEALTH & HUMAN SERVICES AGENCY (HHS)  
TENANT IMPROVEMENT PROJECT**

**BID #19-968-041**

NAME OF BIDDER: \_\_\_\_\_

BUSINESS MAILING ADDRESS: \_\_\_\_\_

CITY, STATE, ZIP: \_\_\_\_\_

BUSINESS STREET ADDRESS: \_\_\_\_\_

*(Please include even if P.O. Box used)*

CITY, STATE, ZIP: \_\_\_\_\_

TELEPHONE NO:      AREA CODE (      ) \_\_\_\_\_

FAX NO:      AREA CODE (      ) \_\_\_\_\_

The work for which this Proposal is submitted is for the construction in accordance with these Bid Documents (including the payment of not less than the State general prevailing wage rates set forth herein), the Project Plans described below, including any addenda thereto, the Contract annexed hereto, and also in accordance with the Labor Surcharge and Equipment Rental Rates in effect on the date the work is accomplished, and in accordance with the General Prevailing Wage rates. The Project Plans and other Bid Documents for the work to be done are entitled:

**SOUTH LAKE TAHOE (SLT)**  
**HEALTH & HUMAN SERVICES AGENCY (HHSA)**  
**TENANT IMPROVEMENT PROJECT**

**BID #19-968-041**

Bids are to be submitted for the entire work. The work includes LUMP SUM BID. Failure to submit a bid for the entire work will result in the bid being deemed non-responsive.

The Bidder shall set forth a lump sum total for the BID, in clearly legible figures in the respective space provided for this purpose.

If the item total for the lump sum is unreadable or otherwise unclear, or is omitted, the bid may be deemed irregular.

Symbols such as commas and dollar signs will be ignored and have no mathematical significance in establishing lump sums. The written lump sum in numbers will be interpreted according to the number of digits and, if applicable, decimal placement. In the event of a discrepancy, the written lump sum in words will govern over the written lump sum in numbers.

The foregoing provisions for the resolution of specific irregularities cannot be so comprehensive as to cover every omission, inconsistency, error or other irregularity which may occur in a bid. Any situation not specifically provided for will be determined in the discretion of the County of El Dorado, and that discretion will be exercised in the manner deemed by the County of El Dorado to best protect the public interest in the prompt and economical completion of the work. The decision of the County of El Dorado respecting the amount of a bid, or the existence or treatment of any irregularity in a bid, shall be final.

If this Proposal is accepted and the undersigned Bidder shall fail to enter into the Contract and furnish the two bonds in the sums required by the State Contract Act, with surety satisfaction to the County of El Dorado in accordance with the Special Provisions within ten (10) calendar days, of the date of the letter notice from the County of El Dorado that the Contract has been awarded, the County of El Dorado may, at its option, determine that the Bidder has abandoned the Contract, and thereupon this Proposal and the acceptance thereof shall be null and void and the forfeiture of such security accompanying this Proposal shall operate and the same shall be the property of the County of El Dorado.

**Attention! The undersigned Bidder acknowledges that a bid security must be submitted in amount of not less than ten percent (10%) of the estimated project cost of \$800,000.00 (\$80,000.00).**

The undersigned, as Bidder, declares under penalty of perjury under the laws of the State of California that the only persons or parties interested in this Proposal, as principals, are those named herein; that this Proposal is made without collusion with any other person, firm, or corporation; that it has carefully examined the location of the proposed work, the annexed proposed form of Contract, and the Plans therein referred to; and that it proposes, and agrees if this Proposal is accepted, that it will contract with the County of El Dorado, in the form of the copy of the Draft Agreement annexed hereto, to provide all necessary machinery, tools, apparatus, and other means of construction, and to do all the work and furnish all the materials specified in the Contract, in the manner and time therein prescribed, and according to the requirements of the Engineer as therein set forth, and that it will take in full payment therefore the following item prices, to wit:

Bidder will be responsible for the tenant improvements of 3368 Sandy Way South Lake Tahoe, California in El Dorado County. The Work to be done as described in the Technical Specifications section and as shown on the Plans, generally consists of, but is not limited to: furnishing of all labor, materials and equipment for the South Lake Tahoe (SLT) Health & Human Services Agency (HHSA) Tenant Improvement Project.

**ALTERNATES:**

- Alternate #1:** ADD – Replacement of five (5) existing windows with new window frame with new fixed reflective insulated glazing. (See plans and specifications for additional information.)
- Alternate #2:** DEDUCT – Reuse and add on to existing PEX piping. (See plans and specifications for additional information.)
- Alternate #3:** DEDUCT – Eliminate two (2) offices at loading dock, infill existing double doors with new storefront to match existing building storefront finishes. (See plans and specifications for additional information.)
- Alternate #4:** DEDUCT – Eliminate Unisex restroom and convert into storage room. (See plans and specifications for additional information.)

**THE USE OF PENCIL OR CORRECTION FLUID OR TAPE IS NOT ACCEPTABLE.  
 BID DOCUMENTS COMPLETED IN PENCIL OR CONTAINING THE USE OF CORRECTION FLUID OR TAPE WILL BE REJECTED.**

**ALL CHANGES MUST BE LINED OUT AND CORRECTIONS INSERTED ADJACENT TO THE CHANGE AND INITIALED BY THE BIDDER'S AUTHORIZED REPRESENTATIVE**

**PROPOSAL BID PRICE SCHEDULE**

**SOUTH LAKE TAHOE (SLT)  
HEALTH & HUMAN SERVICES AGENCY (HHS)  
TENANT IMPROVEMENT PROJECT**

**Note: Bid will be awarded on the basis of the lowest responsive, responsible bidder based upon the total of the LUMP SUM bid and meeting all other requirements.**

**Lump Sum Bid Amount: \$ \_\_\_\_\_**

**Alternate #1 ADD – Window Replacement – Bid Amount: \$ \_\_\_\_\_**

**Alternate #2 DEDUCT – Reuse PEX Pipe – Bid Amount: \$ \_\_\_\_\_**

**Alternate #3 DEDUCT – Eliminate Two Offices – Bid Amount: \$ \_\_\_\_\_**

**Alternate #4 DEDUCT – Unisex Restroom – Bid Amount: \$ \_\_\_\_\_**

NOTICE: Bidder's failure to execute the questionnaire and statements contained in this Bid as required by applicable laws and regulations, or the determinations by the County of El Dorado based upon those questionnaires and statements, may prohibit award of the subject Contract to the Bidder.





**THE USE OF PENCIL OR CORRECTION FLUID OR TAPE IS NOT ACCEPTABLE.  
BID DOCUMENTS COMPLETED IN PENCIL OR CONTAINING THE USE OF CORRECTION FLUID OR  
TAPE WILL BE REJECTED.**

**ALL CHANGES MUST BE LINED OUT AND CORRECTIONS INSERTED ADJACENT TO THE CHANGE AND  
INITIALED BY THE BIDDER'S AUTHORIZED REPRESENTATIVE**

**PUBLIC CONTRACT CODE SECTION 10285.1 STATEMENT**

In accordance with Public Contract Code Section 10285.1 (Chapter 376, Stats. 1985), the Bidder hereby declares under penalty of perjury under the laws of the State of California that the Bidder has \_\_\_\_\_, has not \_\_\_\_\_ been convicted within the preceding three years of any offenses referred to in that Section, including any charge of fraud, bribery, collusion, conspiracy, or any other act in violation of any state or Federal antitrust law in connection with the bidding upon, award of, or performance of, any public works contract, as defined in Public Contract Code Section 1101, with any public entity, as defined in Public Contract Code Section 1100. The term "Bidder" is understood to include any partner, member, officer, director, responsible managing officer, or responsible managing employee thereof, as referred to in Section 10285.1.

**NOTE:** The Bidder must place a check mark after "has" or "has not" in one of the blank spaces provided.

The above Statement is part of the Proposal. Signing this Proposal on the signature portion thereof shall also constitute signature of this Statement.

Bidders are cautioned that making a false certification may subject the certifier to criminal prosecution.

Signature: \_\_\_\_\_

Date: \_\_\_\_\_

Name: \_\_\_\_\_

Title: \_\_\_\_\_

Firm: \_\_\_\_\_

**THE USE OF PENCIL OR CORRECTION FLUID OR TAPE IS NOT ACCEPTABLE.  
BID DOCUMENTS COMPLETED IN PENCIL OR CONTAINING THE USE OF CORRECTION FLUID OR  
TAPE WILL BE REJECTED.**

**ALL CHANGES MUST BE LINED OUT AND CORRECTIONS INSERTED ADJACENT TO THE CHANGE AND  
INITIALED BY THE BIDDER'S AUTHORIZED REPRESENTATIVE**

### **PUBLIC CONTRACT CODE SECTION 10162 QUESTIONNAIRE**

In accordance with Public Contract Code Section 10162, the Bidder shall complete, under penalty of perjury under the laws of the State of California, the following questionnaire:

Has the Bidder, any officer of the Bidder, or any employee of the Bidder who has a proprietary interest in the Bidder, ever been disqualified, removed, or otherwise prevented from bidding on, or completing a federal, state, or local government project because of a violation of law or a safety regulation?

Yes: \_\_\_\_\_ No: \_\_\_\_\_

If the answer is yes, explain the circumstances in the following space:

### **PUBLIC CONTRACT CODE SECTION 10232 STATEMENT**

In accordance with Public Contract Code Section 10232, the Bidder hereby states under penalty of perjury under the laws of the State of California, that no more than one final unappealable finding of contempt of court by a Federal Court has been issued against the Bidder within the immediate preceding two year period because of the Bidder's failure to comply with an order of a Federal Court which orders the Bidder to comply with an order of the National Labor Relations Board.

**NOTE:**

The above Questionnaire and Statement are part of the Proposal. Signing this Proposal on the signature portion thereof shall also constitute signature of this Questionnaire and Statement.

Bidders are cautioned that making a false certification may subject the certifier to criminal prosecution.

**NONCOLLUSION AFFIDAVIT**  
(Title 23 United States Code Section 112 and  
Public Contract Code Section 7106)

In accordance with Title 23 United States Code, Section 112 and Public Contract Code Section 7106, the Bidder declares that the bid is not made in the interest of, or on behalf of, any undisclosed person, partnership, company, association, organization, or corporation; that the bid is genuine and not collusive or sham; that the Bidder has not directly or indirectly induced or solicited any other Bidder to put in false or sham bid, and has not directly or indirectly colluded, conspired, connived, or agreed with any Bidder or anyone else to put in a sham bid, or that anyone shall refrain from bidding; that the Bidder has not in any manner, directly or indirectly, sought by agreement, communication, or conference with anyone to fix the bid price of the Bidder or any other Bidder, or to fix any overhead, profit, or cost element of the bid price, or of that of any other Bidder, or to secure any advantage against the public body awarding the Contract of anyone interested in the proposed Contract; that all statements contained in the bid are true; and, further, that the Bidder has not, directly or indirectly, submitted his or her bid price or any breakdown thereof, or the contents thereof, or divulged information or data relative thereto, or paid, and will not pay, any fee to any corporation, partnership, company, association, organization, bid depository, or to any member or agent thereof to effectuate a collusive or sham bid.

**NOTE:**

The above Noncollusion Affidavit is part of the Proposal. Signing this Proposal on the signature portion thereof shall also constitute signature of this Noncollusion Affidavit.

Bidders are cautioned that making a false certification may subject the certifier to criminal prosecution.

Signature: \_\_\_\_\_

Date: \_\_\_\_\_

Name: \_\_\_\_\_

Title: \_\_\_\_\_

Firm: \_\_\_\_\_



**CONFIDENTIALITY OF INFORMATION PROVIDED**

Contractor shall maintain the confidentiality and privileged nature of all records. Upon completion of all Services, ownership and title to all reports, documents, plans, maps, specifications, estimates, compilations and any and all other materials or data given to Contractor as part of the Services requested shall be returned to the County.

Signature: \_\_\_\_\_

Date: \_\_\_\_\_

Name: \_\_\_\_\_

Title: \_\_\_\_\_

Firm: \_\_\_\_\_

## IRAN CONTRACTING ACT CERTIFICATION

(Public Contract Code Section 22000 *et seq.*)

As required by California Public Contract Code Section 2204, I certify subject to penalty for perjury that: (i) I am duly authorized to execute this certification on behalf of Bidder/Proposer; and (ii) the option checked below relating Bidder/Proposer's status in regard to the Iran Contracting Act of 2010 (Public Contract Code Section 2200 *et seq.*) is true and correct:

\_\_\_ Bidder/Proposer is not:

- (i) Identified on the current list of persons and entities engaging in investment activities in Iran prepared by the California Department of General Services in accordance with subdivision (b) of Public Contract Code Section 2203; or
  
- (ii) A financial institution that extends, for 45 days or more, credit in the amount of \$20,000,000 or more to any other person or entity identified on the current list of persons and entities engaging in investment activities in Iran prepared by the California Department of General Services in accordance with subdivision (b) of Public Contract Code Section 2203, if that person or entity uses or will use the credit to provide goods or services in the energy sector in Iran.

\_\_\_ The County has exempted Bidder/Proposer from the requirements of the Iran Contracting Act of 2010 after making a public finding that, absent the exemption, the County will be unable to obtain the goods and/or services to be provided pursuant to the contract.

Signature: \_\_\_\_\_

Date: \_\_\_\_\_

Name: \_\_\_\_\_

Title: \_\_\_\_\_

Firm: \_\_\_\_\_

*NOTE: In accordance with Public Contract Code Section 2205, false certification of this form shall be reported to the California Attorney General and may result in civil penalties equal to the greater of \$250,000 or twice the contract amount, termination of the contract and/or ineligibility to bid on public contracts for three (3) years.*

Accompanying this proposal is \_\_\_\_\_

(NOTICE: INSERT THE WORDS "CASH (\$\_\_\_\_)," "CASHIER'S CHECKS," "CERTIFIED CHECKS," OR "BIDDERS BONDS," AS THE CASE MAY BE)

**in amount equal to at least ten percent (10%) of the total of the estimated project cost of \$800,000.00 (\$80,000.00).**

**The names of all persons interested in the forgoing Proposal as principals are as follows:**

**IMPORTANT NOTICE:** If the Bidder or other interested person is a corporation, state legal name of corporation and place of incorporation, also names of the president, secretary, treasurer, and executive officer thereof; if a partnership, state name of partnership, also names of all individual partners; if Bidder or other interested person is an individual, state first and last names in full.

\_\_\_\_\_  
\_\_\_\_\_  
\_\_\_\_\_

Licensed in accordance with an act providing for the registration of Contractors,

License No. \_\_\_\_\_ Classification(s) \_\_\_\_\_

**A copy of the afore-referenced license must be attached hereto.**

**ADDENDA:** This Proposal is submitted with respect to the changes to the Contract included in addenda number(s)

\_\_\_\_\_  
(Fill in addenda numbers if addenda have been received and insert, in this Proposal, any Proposal Pay Items and Bid Price Schedules that were received as part of the addenda)

By my signature on this Proposal I certify, under penalty of perjury under the laws of the State of California, that the foregoing questionnaire and statements of Public Contract Code Sections 10162, 10232, and 10285.1 are true and correct and that I have complied with the requirements of Section 8103 of the Fair Employment and Housing Commission Regulations (Chapter 5 of Division 4 of Title 2 of the California Code of Regulations). By my signature on this Proposal I further certify, under penalty of perjury under the laws of the State of California and the United States of America that the Noncollusion Affidavit required by Title 23 United States Code, Section 112 and Public Contract Code Section 7106 is true and correct.

The person or persons executing this Proposal on behalf of a corporation or partnership shall be prepared to demonstrate by resolution, article, or otherwise, that such person is or that such persons are appropriately authorized to act in these regards for such corporation or partnership. Such authority shall be demonstrated to the satisfaction of the County of El Dorado.

If the signature is by an agent other than an officer of a corporation or a member of a partnership, a power of attorney authorizing said act by the agent on behalf of his principal shall be submitted with the bid forms; otherwise, the bid may be disregarded as irregular and unauthorized.

The Bidder's execution on the signature portion of this Proposal shall constitute an endorsement and execution of those affidavits, declarations and certifications which are part of this Proposal.

Executed this \_\_\_\_\_ day of \_\_\_\_\_, 20\_\_

at: \_\_\_\_\_ County, State of \_\_\_\_\_

Date: \_\_\_\_\_

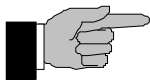

**SIGN HERE:** \_\_\_\_\_

Name and Title of Bidder: \_\_\_\_\_

Name of Firm: \_\_\_\_\_

**END OF PROPOSAL**

**COUNTY OF EL DORADO**

**BIDDER'S BOND**

**this form MUST be used**

**KNOW ALL PEOPLE BY THESE PRESENTS, THAT WE** \_\_\_\_\_  
\_\_\_\_\_, as **PRINCIPAL**, and  
\_\_\_\_\_

as Surety are held and firmly bound unto the County of El Dorado (Obligee), in the penal sum of **TEN (10) PERCENT OF THE AMOUNT OF THE TOTAL LUMP SUM BID PRICE** of the Principal above named, submitted by said Principal to the Obligee for the work described below, for the payment of which sum in lawful money of the United States, well and truly to be made to the Obligee, we the Principal and Surety bind ourselves, our heirs, executors, administrators and successors, jointly and severally, firmly by these presents. In no case shall the liability of the Surety hereunder exceed the sum of

**TEN PERCENT (10%) OF THE TOTAL OF THE ESTIMATED PROJECT COST OF \$800,000.00 (\$80,000.00)**

**THE CONDITION OF THIS OBLIGATION IS SUCH, THAT:**

**WHEREAS**, the Principal has submitted the above-mentioned Bid to the Obligee, as aforesaid, for certain construction specifically described as follows, for which bids are to be opened at Placerville, El Dorado County, California, for the construction of the:

**SOUTH LAKE TAHOE HEALTH & HUMAN SERVICES AGENCY (HHS)**  
**TENANT IMPROVEMENT PROJECT**

**NOW, THEREFORE**, if the aforesaid Principal is awarded the Contract and, within the time and manner required under the Bid Documents, after the prescribed forms are presented to it for signature, enters into a written contract, in the prescribed form, in accordance with the Bid, and files two bonds with the County of El Dorado, one to guarantee faithful performance and the other to guarantee payment for labor and materials, as required by law, then this obligation shall be null and void; otherwise, it shall remain in full force and virtue.

In the event suit is brought upon this bond by the Obligee and judgment is recovered, the Surety shall pay all costs incurred by the Obligee in such suit, including a reasonable attorney's fee to be fixed by the Court.

IN WITNESS WHEREOF, we have set our hands and seals on this \_\_\_\_\_ day of \_\_\_\_\_ 20\_\_\_\_

(seal) \_\_\_\_\_  
Principal

(seal) \_\_\_\_\_  
Surety

Address: \_\_\_\_\_  
\_\_\_\_\_

(NOTE: Signature of those executing for the Surety shall be properly acknowledged, and accompanied by a Certificate of Acknowledgment.)

**PRINCIPAL**

A notary public or other officer completing this certificate verifies only the identity of the individual who signed the document to which this certificate is attached, and not the truthfulness, accuracy, or validity of that document.

**ACKNOWLEDGMENT**

State of California

County of \_\_\_\_\_

On before me, \_\_\_\_\_,  
(here insert name and title of the officer)

personally appeared \_\_\_\_\_  
\_\_\_\_\_  
\_\_\_\_\_ ,

who proved to me on the basis of satisfactory evidence to be the person(s) whose name(s) is/are subscribed to the within instrument and acknowledged to me that he/she/they executed the same in his/her/their authorized capacity(ies), and that by his/her/their signature(s) on the instrument the person(s), or the entity upon behalf of which the person(s) acted, executed the instrument.

I certify under PENALTY OF PERJURY under the laws of the State of California that the foregoing paragraph is true and correct

WITNESS my hand and official seal.

Signature \_\_\_\_\_

(Seal)

**SURETY**

A notary public or other officer completing this certificate verifies only the identity of the individual who signed the document to which this certificate is attached, and not the truthfulness, accuracy, or validity of that document.

**ACKNOWLEDGMENT**

State of California

County of \_\_\_\_\_

On before me, \_\_\_\_\_,  
(here insert name and title of the officer)

personally appeared \_\_\_\_\_

\_\_\_\_\_

\_\_\_\_\_ ,

who proved to me on the basis of satisfactory evidence to be the person(s) whose name(s) is/are subscribed to the within instrument and acknowledged to me that he/she/they executed the same in his/her/their authorized capacity(ies), and that by his/her/their signature(s) on the instrument the person(s), or the entity upon behalf of which the person(s) acted, executed the instrument.

I certify under PENALTY OF PERJURY under the laws of the State of California that the foregoing paragraph is true and correct.

WITNESS my hand and official seal.

Signature \_\_\_\_\_

(Seal)

# County of El Dorado, State of California

## SOUTH LAKE TAHOE (SLT) HEALTH AND HUMAN SERVICES AGENCY (HHS) TENANT IMPROVEMENT PROJECT

**BID #19-968-041**

**THIS AGREEMENT** ("Agreement") approved by the County of El Dorado Board of Supervisors, this \_\_\_\_\_ day of \_\_\_\_\_, in the year of 20\_\_, made and concluded, in duplicate, between the COUNTY OF EL DORADO, a political subdivision of the State of California, by the Chief Administrative Office, Facilities Division thereof, the party of the first part hereinafter called "County," and \_\_\_\_\_ (Contractor) party of the second part hereinafter called "Contractor."

### **R E C I T A L S**

**WHEREAS**, County has caused the above-captioned project to be let to formal bidding process; and

**WHEREAS**, Contractor has duly submitted a bid response for the captioned project upon which County has awarded this Contract.

**NOW, THEREFORE**, the parties hereto have mutually covenanted and agreed, and by these presents do covenant and agree, each with the other, as follows:

#### **Article 1. THE WORK**

The improvement contemplated in the performance of this Contract is an improvement over which the County of El Dorado shall exercise general supervision. The County therefore, shall have the right, but not the duty to assume full and direct control over this Contract whenever the County at its sole discretion, shall determine that its responsibility is so required.

The Contractor shall complete the Work as specified or indicated under the County's Bid Documents entitled:

## SOUTH LAKE TAHOE (SLT) HEALTH & HUMAN SERVICES AGENCY (HHS) TENANT IMPROVEMENT PROJECT

The project is located at 3368 Sandy Way South Lake Tahoe, California in El Dorado County. The Work to be done as described in the Technical Specifications section and as shown on the Plans, generally consists of, but is not limited to: furnishing of all labor, materials and equipment for South Lake Tahoe (SLT) Health & Human Services Agency (HHS) Tenant Improvement Project:

- Alternate #1: ADD** – Replacement of five (5) existing windows with new window frame with new fixed reflective insulated glazing. (See plans and specifications for additional information.)
- Alternate #2: DEDUCT** – Reuse and add on to existing PEX piping. (See plans and specifications for additional information.)
- Alternate #3: DEDUCT** – Eliminate two (2) offices at loading dock, infill existing double doors with new storefront to match existing building storefront finishes. (See plans and specifications for additional information.)

**Alternate #4: DEDUCT** – Eliminate Unisex restroom and convert into storage room. (See plans and specifications for additional information.)

## **Article 2. CONTRACT DOCUMENTS**

The Contract Documents consist of: the Notice to Bidders; Supplemental Instructions to Bidders; the bid forms which include the accepted Proposal, Proposal Bid Price Schedule, Subcontractors Listing, Section 10285.1 Statement, Section 10162 Questionnaire, Section 10232 Statement, and the Noncollusion Affidavit; the Contract which includes this Agreement with all Exhibits thereto, the Performance Bond and Payment Bond; Conditions of the Contract; the drawings, specification and diagrams, listed and identified as the Project Plans; all Addenda incorporated in those documents before their execution, all Contract Change Orders, Architect's Supplemental Instructions, and Construction Change Directives issued in accordance with the Contract Documents which may be delivered or issued after the Effective Date of this Agreement and are not attached hereto; the prevailing Labor Surcharge And Equipment Rental Rates (when required) as determined by the Department of Industrial Relations to be in effect on the date the Work is accomplished; all the obligations of County and of Contractor which are fully set forth and described therein; and all Contract Documents which are hereby specifically referred to and by such reference made a part hereof. All Contract Documents are intended to cooperate so that any work called for in one and not mentioned in the other is to be executed the same as if mentioned in all Contract Documents. Contractor agrees to perform all of its promises, covenants, and conditions set forth in the Contract Documents, and to abide by and perform all terms and conditions set forth therein. In case of conflict between this Agreement and any other contract document, this Agreement shall take precedence.

## **Article 3. CONTRACT PRICE**

As compensation agreed upon for said Work, County shall pay or cause to be paid to Contractor, in full, and for the full contract price and compensation for said completion of the Work, including without limitation, all bonds and insurance, **THE NOT TO EXCEED SUM OF** (insert dollar amount in words) **DOLLARS** (\$(insert dollar amount in numbers)) which sum constitutes the Contract Price for the complete Project (the "Contract Price").

## **Article 4. COMMENCEMENT AND COMPLETION**

The Work to be performed under this Contract shall commence on the date specified in the Notice to Proceed issued by County. The work shall be diligently prosecuted to completion within **ninety six (96) calendar days** commencing from the date shown on the Contractor Notice to Proceed.

County and Contractor recognize that time is of the essence of the Agreement and that County will suffer loss if the Work is not completed within the time specified in the above paragraph, plus any extensions thereof allowed in accordance with Article 4.3.5 of the Conditions of the Contract. The parties also recognize delays, expense, and difficulties involved with proving in a legal proceeding the actual loss suffered by County if the Work is not completed on time. Accordingly, instead of requiring any such proof, County and Contractor agree that as liquidated damages for delay (but not as a penalty), Contractor shall pay County the sum of **ONE THOUSAND, FIVE HUNDRED DOLLARS (\$1,500)** for each and every calendar day, as liquidated damages and not as a penalty, for each and every calendar day's delay in finishing the Work in excess of the contract time prescribed herein; and Contractor agrees that County may deduct the amount thereof from any monies due or that may become due Contractor under this contract.

## **Article 5. PAYMENT**

Payment shall be made to Contractor as follows:

Progress payments are to be made monthly based on the percentage of completion method reached by the Contractor and invoiced using Exhibit "A", marked "Application and Certificate for Payment" incorporated herein and made by reference a part hereof.



Retention of 5% of the total Contract price will be held until the work is 50% complete, and thereafter at the option of County. Payment by County as herein provided shall not be construed as an absolute acceptance of defects in the work or improper materials.

#### **Article 6. INDEMNITY**

To the fullest extent allowed by law, Contractor shall defend, indemnify, and hold the County and its officers, directors, and employees harmless against and from any and all claims, suits, losses, damages, and liability for damages, including attorney's fees and other costs of defense brought for or on account of injuries to or death of any person, including but not limited to, workers and the public, or on account of injuries to or death of County employees, or damage to property, or any economic, consequential or special damages which are claimed or which shall in any way arise out of or be connected with Contractor's services, operations or performance hereunder, regardless of the existence or degree of fault or negligence on the part of the County, the Contractor, subcontractors or employees of any of these, except for the active, or sole negligence of the County, its officers and employees, or where expressly prescribed by statute.

The duty to indemnify and hold harmless the County specifically includes the duties to defend set forth in Section 2778 of the Civil Code. The insurance obligations of the Contractor are separate, independent obligations under the Contract Documents, and the provisions of this defense and indemnity are not intended to modify nor should they be construed as modifying or in any way limiting the insurance obligations set forth in the Contract Documents.

#### **Article 7. GUARANTEES**

Contractor shall repair or replace any or all work provided hereunder which is defective due to faulty materials, poor workmanship, or defective equipment at no expense to County, ordinary wear or tear and unusual abuse or neglect excepted, during the term of the Contract and for a period of one (1) year after Notice of Acceptance. Contractor shall be required to repair or replace any and all adjacent facilities or areas which have been damaged or displaced due to Contractor work performed under this Agreement at no expense to County during the term of this Contract and for a period of one (1) year after Notice of Acceptance.

If a warranty or guarantee exceeding one (1) year is provided by the supplier or manufacturer of any equipment or materials used in this Project, or if a warranty or guarantee exceeding one (1) year is required elsewhere in these Contract Documents, then the guarantee for such equipment or materials shall be extended for such term. Contractor expressly agrees to act as co-guarantor of such equipment and materials, and Contractor shall supply County with all warranty and guaranty documents relative to equipment and materials incorporated in the job and guaranteed by its suppliers or manufacturers.

The parties agree that this guarantee and the rights and obligations accruing therefrom shall be in addition to, and not by way of limitation in any manner whatsoever to, the rights, obligations, warranties or remedies otherwise provided for by law.

In the event of Contractor's failure to comply with the above mentioned conditions within ten (10) calendar days after being notified in writing by County, Contractor hereby authorizes County to proceed to have said defects repaired and made good at Contractor's expense, and Contractor will honor and pay all costs and charges therefore upon written demand.

#### **Article 8. NOTICE**

Any notice or other correspondence required to be given under this Agreement by either party to the other may be affected by personal delivery in writing or by mail, postage prepaid. Notices personally delivered during normal business hours shall be deemed received on the actual date of delivery; mailed notices shall be deemed received one (1) day after affixed postmark. Notices and correspondence to County shall be in duplicate and shall be delivered to it as follows:

Chief Administrative Office  
3000 Fairlane Court, Suite One  
Placerville, CA 95667

Attn.: Russell Fackrell  
Facilities Division Manager

Notices and correspondence to Contractor shall be delivered when personally delivered to, or if mailed, addressed to Contractor at:

Contractor's Business Name  
Street Address  
City, State Zip

Attn.: Name of Notices Recipient  
Title of Notices Recipient

Either party may change its address for notices by giving written notice pursuant to this Article.

**Article 9. VENUE**

The Contract Documents and all provisions thereto shall be governed by the laws of the State of California. Any litigation arising out of this Contract shall be brought in El Dorado County.

**Article 10. PERFORMANCE BOND**

As a part of the execution of this Contract, Contractor shall furnish a bond of a surety company authorized to do business in the State of California, conditioned upon the faithful performance of all covenants and stipulations under this Contract. The amount of this bond shall be one hundred percent (100%) of the total Contract Price and shall be executed upon the form provided by County.

**Article 11. PAYMENT BOND**

As a part of the execution of this Contract, Contractor shall furnish a bond of a surety company authorized to do business in the State of California, conditioned upon the payment in full of all claims for labor and materials in accordance with the provisions of the law of the State of California. The amount of this bond shall be one hundred percent (100%) of the total Contract Price and shall be executed upon the form provided by County.

**Article 12. NOTIFICATION OF SURETY COMPANY**

The surety company shall familiarize itself with all of the conditions and provisions of this Contract, and shall waive the right of special notification of any change or modifications of this Contract or extension of time, or of decreased or increased work, or of the cancellation of the Contract, or of any other act or acts by County or its authorized agents, under the terms of this Contract; and failure to so notify the aforesaid surety company of changes shall in no way relieve the surety company of its obligation under this Contract.

**Article 13. ASSIGNMENT OF ANTITRUST ACTIONS**

In entering into a public works contract or a subcontract to supply goods, services, or materials pursuant to a public works contract, the Contractor offers and agrees and will require all of its subcontractors and suppliers to agree to assign to the awarding body all rights, title, and interest in and to all causes of action it may have under Section 4 of the Clayton Act (15 U.S.C. Sec. 15) or under the Cartwright Act (Chapter 2 (commencing with Section 16700) of Part 2 of Division 7 of the Business and Professions Code), arising from purchases of goods, services, or materials pursuant to the public works contract or the subcontract. This assignment shall be made and become effective at the time the awarding body tenders final payment to Contractor, without further acknowledgment by the parties.

If an awarding body or public purchasing body receives, either through judgment or settlement, a monetary recovery for a cause of action assigned under Government Code Sections 4550-4554, the assignor shall be entitled to receive reimbursement for actual legal costs incurred and may, upon demand, recover from the public body any portion of the recovery, including treble damages, attributable to overcharges that were paid by the assignor but were not paid by the public body as part of the

bid price, less the expenses incurred in obtaining that portion of the recovery. Upon demand in writing by the assignor, the assignee shall, within one year from such demand, reassign the cause of action assigned under Government Code Sections 4550-4554 if the assignor has been or may have been injured by the violation of law for which the cause of action arose and (a) the assignee has not been injured thereby, or (b) the assignee declines to file a court action for the cause of action.

#### **Article 14. TERMINATION BY COUNTY FOR CONVENIENCE**

County reserves the right to terminate the Contract at any time upon determination by County's representative that termination of the Contract is in the best interest of County. County shall issue Contractor a written notice specifying that the Contract is to be terminated.

Upon receipt of said written notice, Contractor shall stop all work under the Contract except: (1) work specifically directed to be completed prior to termination, (2) work the Inspector deems necessary to secure the project for termination, (3) removal of equipment and plant from the site of the Work, (4) action that is necessary to protect materials from damage, (5) disposal of materials not yet used in the Work as directed by County, and (6) clean up of the site.

If the Contract is terminated for County's convenience as provided herein, all finished or unfinished work and materials previously paid for shall, at the option of County, become its property. Contractor shall be paid an amount which reflects costs incurred for work provided to the date of notification of termination. In addition, Contractor shall be paid the reasonable cost, as solely judged by County, and without profit, for all work performed to secure the project for termination.

#### **Article 15. TERMINATION BY COUNTY FOR CAUSE**

If Contractor is adjudged as bankrupt or insolvent, or makes a general assignment for the benefit of its creditors or if a trustee or receiver is appointed for Contractor or for any of its property, or if Contractor files a petition to take advantage of any debtor's act, or to reorganize under the bankruptcy or applicable laws, or on more than one occasion fails to supply sufficient skilled workmen or suitable material or equipment, or on more than one occasion fails to make prompt payments to subcontractors for labor, materials, or equipment, or disregards the authority of the County's representative, or the Engineer, if one is appointed, or otherwise violates any provision of the Contract Documents, then County may, without prejudice to any other right or remedy and after giving Contractor and its Surety a minimum of ten (10) calendar days from delivery of a written termination notice, terminate the services of Contractor and take equipment and machinery thereon owned by Contractor and finish the Work by whatever method County may deem expedient. In such case, Contractor shall not be entitled to receive any further payment until the Work is finished.

Without prejudice to other rights or remedies County may have, if Contractor fails to begin delivery of materials and equipment, to commence Work within the time specified, to maintain the rate of delivery of material, to execute the Work in the manner and at such locations as specified, or fails to maintain a work program which will ensure County's interest, or, if Contractor is not carrying out the intent of the Contract, an Inspector's written notice may be served upon Contractor and the Surety on its faithful performance bond demanding satisfactory compliance with the Contract. If Contractor or its Surety does not comply with such notice within five (5) calendar days after receiving it, or after starting to comply, fails to continue, County may exclude it from the premises and take possession of all material and equipment, and complete the Work by County's own forces, by letting the unfinished Work to another Contractor, or by a combination of such methods.

Where Contractor's services have been so terminated by County, said termination shall not affect any right of County against Contractor then existing or which may thereafter accrue. Any retention or payment of monies by County due Contractor will not release Contractor from compliance with the Contract Documents.

If the unpaid balance of the Contract price exceeds the direct and indirect costs of completing the Work, including compensation for additional professional services, such excess shall be paid to Contractor. If the sums under the Contract are insufficient for completion, Contractor or Surety shall pay to County within five (5) calendar days after the completion, all costs in excess of the Contract price. In any event, the cost of completing the Work shall be charged against Contractor and its Surety and may be deducted from any money due or becoming due from County.

The provisions of this Article shall be in addition to all other rights and remedies available to County under law.

If after notice of termination, it is determined for any reason that Contractor was not in default, the rights and obligations of the parties shall be the same as if the notice of termination had not been issued. The Contract shall be equitably adjusted to compensate for such termination.

**Article 16. SUCCESSORS AND ASSIGNS**

This Agreement shall bind and inure to the heirs, devisees, assignees, and successors in interest of Contractor and to the successors in interest of County in the same manner as if such parties had been expressly named herein.

**Article 17. REPORTING ACCIDENTS**

Contractor shall prepare and submit (within 24 hours of such incidents) reports of accidents at the site and anywhere else the work is in progress in which bodily injury is sustained or property loss in excess of Five Hundred Dollars (\$500.00) occurs.

**Article 18. WORKERS' COMPENSATION CERTIFICATION**

Contractor shall comply with Labor Code Sections 3700 et seq., requiring it to obtain Workers' Compensation Insurance, and sign a certificate of knowledge thereof.

**CERTIFICATE OF KNOWLEDGE - LABOR CODE SECTION 3700**

I am aware of the provisions of Section 3700 of the Labor Code, which require every employer to be insured against liability for workers' compensation or to undertake self-insurance in accordance with the provisions of that Code, and I will comply with such provisions before commencing the performance of work of this Contract.

Signed: \_\_\_\_\_ Date: \_\_\_\_\_

**Article 19. WARRANTY**

Contractor warrants to County that materials and equipment furnished for the Work will be of good quality and new, unless otherwise required or permitted under the Contract Documents, that the Work will be free from defects or flaws and is of the highest quality of workmanship and that the Work will conform with the requirements herein. Work not conforming to these requirements, including substitutions not properly approved and authorized, shall be considered defective.

**Article 20. RETAINAGE**

The retainage from payments is set forth in Section 6.4 "WITHHOLDINGS FROM PAYMENTS" of the Conditions of the Contract. Contractor may elect to receive one hundred percent (100%) of payments due as set forth in the Contract Documents, without retention, by depositing securities of equivalent value with County, in accordance with, and as set forth in Section 22300 of the Public Contract Code. Securities eligible for deposit hereunder shall be limited to those listed in Section 16430 of the Government Code, or bank or savings and loan certificates of deposit.

**Article 21. RESOLUTION OF CLAIMS**

Contractor's attention is directed to California Public Contract Code Section 9204, which describes procedures for the resolution of claims on public works projects. Among other things, Section 9204 requires the claimant to furnish reasonable documentation to support a claim, requires the public entity to respond to the claim within forty-five (45) days of receipt of the claim, and allows for the claimant to demand an informal meet and confer conference for settlement of the issues in dispute. For any portion of a claim that remains in dispute, Section 9204 requires submission of the claim to nonbinding mediation. Additionally, Section 9204 requires the public entity to make any payment due on an undisputed portion of the claim within sixty (60) days of the public entity's written response and to pay interest at the rate of seven percent (7%) per

annum on any amounts not paid in a timely manner. The provisions of Sections 20104 et seq. also apply to the resolution of claims under this Contract to the extent those sections are not in conflict with Section 9204.

**Article 22. PREVAILING WAGE REQUIREMENTS**

In accordance with the provisions of California Labor Code Sections 1770 et seq., the general prevailing rate of wages in the county in which the Work is to be done has been determined by the Director of the California Department of Industrial Relations. Interested parties can obtain the current wage information by submitting their requests to the Department of Industrial Relations, Division of Labor Statistics and Research, P.O. Box 420603, San Francisco, CA 94142-0603, Telephone (415) 703-4708 or by referring to the website at <http://www.dir.ca.gov/dlsr/PWD>. The rates at the time of the bid advertisement date of a project will remain in effect for the life of the project in accordance with the California Code of Regulations, as modified and effective January 27, 1997.

Copies of the general prevailing rate of wages in the county in which the Work is to be done are also on file at the Chief Administrative Office, Facilities Division, and are available upon request.

In accordance with the provisions of Labor Code 1810, eight (8) hours of labor shall constitute a legal day's work upon all work done hereunder, and Contractor and any subcontractor employed under this Contract shall conform to and be bound by the provisions of Labor Code Sections 1810 through 1815.

This Project is subject to the requirements of Title 8, Chapter 8, Subchapter 4.5 of the California Code of Regulations including the obligation to furnish certified payroll records directly to the Compliance Monitoring Unit under the Labor Commissioner within the Department of Industrial Relations Division of Labor Standards Enforcement in accordance with Section 16461.

**Article 23. CONTRACTOR REGISTRATION**

In accordance with California Labor Code Section 1771.1, a contractor or subcontractor shall not be qualified to bid on, be listed in a bid proposal, subject to the requirements of Section 4104 of the Public Contract Code, or engage in the performance of any contract for public work, as defined in this chapter, unless currently registered and qualified to perform public work pursuant to Section 1725.5. It is not a violation of this section for an unregistered contractor to submit a bid that is authorized by Section 7029.1 of the Business and Professions Code or by Section 10164 or 20103.5 of the Public Contract Code, provided the contractor is registered to perform public work pursuant to Section 1725.5 at the time the contract is awarded.

The contractor must post job site notices as prescribed by regulation 8 California Code of Regulations Section 16451. All contractors and subcontractors must furnish electronic certified payroll records directly to the Department of Industrial Relations (DIR). The work is subject to compliance monitoring and enforcement by the DIR.

**Article 24. AUDIT BY CALIFORNIA STATE AUDITOR**

Audit by California State Auditor: Contractor acknowledges that if total compensation under this agreement is greater than \$10,000.00, this Agreement is subject to examination and audit by the California State Auditor for a period of three (3) years, or for any longer period required by law, after final payment under this Agreement, pursuant to California Government Code §8546.7. In order to facilitate these potential examinations and audits, Contractor shall maintain, for a period of at least three (3) years, or for any longer period required by law, after final payment under the contract, all books, records and documentation necessary to demonstrate performance under the Agreement.

**Article 25. TAXES**

Contractor certifies that as of today's date, it is not in default on any unsecured property taxes or other taxes or fees owed by Contractor to County. Contractor agrees that it shall not default on any obligations to County during the term of this Agreement.

**Article 26. CHILD SUPPORT COMPLIANCE ACT**

For any Agreement in excess of \$100,000.00, the Contractor acknowledges in accordance with Public Contract Code 7110, that:

- a) The Contractor recognizes the importance of child and family support obligations and shall fully comply with all applicable state and federal laws relating to child and family support enforcement, including, but not limited to, disclosure of information and compliance with earnings assignment orders, as provided in Chapter 8 (commencing with section 5200) of Part 5 of Division 9 of the Family Code; and
- b) The Contractor, to the best of its knowledge is fully complying with the earnings assignment orders of all employees and is providing the names of all new employees to the New Hire Registry maintained by the California Employment Development Department.

**Article 27. LICENSES**

Contractor warrants and represents that it holds a valid California license pursuant to the Contractors' State License Law (Business and Professions Code Sections 7000, et seq.), that its license is in good standing and that it possesses Class B – General Building Contractor License, as required by the categories and type of the Work. Copies of Contractor's State Contractors' license must be provided with this Agreement.

In addition, Contractor hereby represents and warrants that Contractor and any of its subcontractors employed under this Agreement has all the applicable licenses, permits, and certifications that are legally required for Contractor and its subcontractors to practice its profession or provide the services or work contemplated under this Agreement in the State of California. Contractor and its subcontractors shall obtain or maintain said applicable licenses, permits, or certificates in good standing throughout the term of this Agreement

**Article 28. BUSINESS LICENSE**

The County Business License Ordinance provides that it is unlawful for any person to furnish supplies or services, or transact any kind of business in the unincorporated territory of El Dorado County without possessing a County business license unless exempt under County Ordinance Code Section 5.08.070. Contractor warrants and represents that it shall comply with all of the requirements of the County Business License Ordinance, where applicable, prior to beginning work under this Contract and at all times during the term of this Contract.

**Article 29. CONTRACT ADMINISTRATOR**

The County Officer or employee with responsibility for administering this Agreement is Russell Fackrell, Facilities Division Manager, Chief Administrative Office, or successor.

**Article 30. AUTHORIZED SIGNATURES**

The parties hereto represent that the undersigned individuals executing this Agreement on their behalf are fully authorized to do so by law or other appropriate instrument and to bind upon said parties the obligations set forth herein.

**Article 31. PARTIAL INVALIDITY**

If any provision of this Agreement is held by a court of competent jurisdiction to be invalid, void or unenforceable, the remaining provisions will continue in full force and effect without being impaired or invalidated in any way.



**IN WITNESS WHEREOF**, the County and Contractor have executed this Agreement on the dates indicated below, the latest shall be deemed to be the effective date of this Agreement.

**COUNTY OF EL DORADO**

By: \_\_\_\_\_ Dated: \_\_\_\_\_  
\_\_\_\_\_, Chair  
Board of Supervisors  
County of El Dorado

ATTEST:  
James S. Mitrison, Clerk  
Of the Board of Supervisors

By: \_\_\_\_\_ Dated: \_\_\_\_\_  
Deputy Clerk

**CONTRACTOR**

By: \_\_\_\_\_ Dated: \_\_\_\_\_  
President

By: \_\_\_\_\_ Dated: \_\_\_\_\_  
Secretary

License No.: \_\_\_\_\_ Federal Employer Identification No. \_\_\_\_\_

NOTE: If Contractor is a corporation, the legal name of the corporation shall be set forth above together with the signature of the officer or officers authorized to sign contracts on behalf of the corporation; if Contractor is a co-partnership, the true name of the firm shall be set forth above together with the signature of the partner or partners authorized to sign contracts on behalf of the co-partnership; and if Contractor is an individual, his/her signature shall be placed above. Contractor executing this document on behalf of a corporation or partnership shall be prepared to demonstrate by resolution, article, or otherwise that it is appropriately authorized to act in these regards. For such corporation or partnership, such authority shall be demonstrated to the satisfaction of County. If signature is by an agent, other than officer of a corporation or a member of a partnership, an appropriate Power of Attorney shall be on file with the Department prior to signing this document.

Mailing Address: \_\_\_\_\_

Business Address: \_\_\_\_\_

City, Zip: \_\_\_\_\_

Phone: \_\_\_\_\_ Fax: \_\_\_\_\_

**\* END OF AGREEMENT \***



**APPLICATION AND CERTIFICATE FOR PAYMENT - EXHIBIT A**

TO OWNER: PROJECT:

El Dorado County  
 360 Fair Lane  
 Placerville, CA 95667  
 FROM CONTRACTOR:

APPLICATION #: 1 Distribution to:

PERIOD TO:  
 PROJECT NOS:

County	
Cont Adm	
Contractor	

CONTRACT DATE:

**CONTRACTOR'S APPLICATION FOR PAYMENT**

Application is made for payment, as shown below, in connection with the Contract. Continuation Sheet is attached.

- 1. ORIGINAL CONTRACT SUM----- \$
- 2. Net change by Change Orders-----\$
- 3. CONTRACT SUM TO DATE (Line 1 +/- 2)
- 4. TOTAL COMPLETED & STORED TO DATE-\$  
 (Column G on Continuation Sheet)

- 5. RETAINAGE:
  - a. \_\_\_\_\_ of Completed Work  
 (Columns D+E on Continuation Sheet) \$
  - b. \_\_\_\_\_ of Stored Material  
 (Column F on Continuation Sheet) \$

Total Retainage (Line 5a + 5b or Total in Column 1 of Continuation Sheet----- \$

6. TOTAL EARNED LESS RETAINAGE----- \$

(Line 4 less Line 5 Total)

**7. LESS PREVIOUS CERTIFICATES FOR PAYMENT**

(Line 6 from prior Certificate)----- \$

8. CURRENT PAYMENT DUE----- \$

9. BALANCE TO FINISH, INCLUDING RETAINAGE

(Line 3 less Line 6) \$

CHANGE ORDER SUMMARY	ADDITIONS	DEDUCTIONS
Total changes approved in previous months by Contract Administrator		
Total approved this Month		
<b>TOTALS</b>		
<b>NET CHANGES by Change Order</b>		

The undersigned Contractor certifies that to the best of the Contractor's knowledge, information and belief the Work covered by this Application for Payment has been completed in accordance with the Contract Documents, that all amounts have been paid by the Contractor for Work for which previous Certificates for Payment were issued and payments received from the Owner, and that current payment shown therein is now due.

CONTRACTOR:

By: \_\_\_\_\_ Date: \_\_\_\_\_

State of: California  
 County of: El Dorado

**CERTIFICATE FOR PAYMENT**

In accordance with Contract Documents, based on on-site observations and the data comprising application, the Contract Administrator certifies to El Dorado County that to the best of the Contract Administrator's knowledge, information and belief the Work has progressed as indicated, the quality of the Work is in accordance with the Contract Documents, and the Contractor is entitled to payment of the AMOUNT CERTIFIED.

AMOUNT CERTIFIED ----- \$

(Attach explanation if amount certified differs from the amount applied for. Initial all figures on this application and on the Continuation Sheet that are changed to conform to the amount certified.)

CONTRACT ADMINISTRATOR

By: \_\_\_\_\_ Date: \_\_\_\_\_

This Certificate is not negotiable. The AMOUNT CERTIFIED is payable only to the Contractor named herein. Issuance, payment and acceptance of payment are without prejudice to any rights of the Owner of Contractor under this Contract.

**CONTINUATION SHEET**

ATTACHMENT TO PAY APPLICATION

APPLICATION NUMBER: 1

PROJECT:

APPLICATION DATE:

PERIOD TO:

CONTRACTOR'S PROJECT NO:

A Item No.	B Description of Work	C Scheduled Value	D		E Work Completed This Period	F Materials Presently Stored (Not In D or E)	G Total Completed And Stored To Date (D + E + F)	H Balance To Finish (C - G)	I Retainage
			From Previous Application (D + E)	Work Completed This Period					
1									
2									
3									
4									
5									
6									
7									
8									
9									
10									
11									
12									
13									
14									
15									
16									
17									
18									
19									
20									
21									
22									
23									
24									
25									
26									
27									
28									
<b>SUBTOTALS PAGE 2</b>									

**CONTRACTOR'S GUARANTEE**

**COUNTY OF EL DORADO  
SOUTH LAKE TAHOE (SLT)  
HEALTH & HUMAN SERVICES AGENCY (HHS) (HSA)  
TENANT IMPROVMENT PROJECT**

**BID #19-968-041**

As Contractor for the above referenced project, we hereby agree to repair or replace any or all work provided hereunder which is defective due to faulty materials, poor workmanship, or defective equipment at no expense to the County of El Dorado, ordinary wear and tear and unusual abuse or neglect excepted, during the term of the contract and provide the manufacturer one (1) year warranty period from the date of final acceptance of the work.

We further agree to repair or replace any and all adjacent areas which have been damaged or displaced due to our work performed under this contract at no expense to the County of El Dorado during the term of this contract for a period of one (1) year from the date of final acceptance of the work.

If a warranty or guarantee exceeding one (1) year is provided by the supplier or manufacturer of any equipment or materials used in this Project, or if a warranty or guarantee exceeding one (1) year is required elsewhere in these Contract Documents, then the guarantee for such equipment or materials shall be extended for such term. We expressly agrees to act as co-guarantor of such equipment and materials, and we shall supply County with all warranty and guaranty documents relative to equipment and materials incorporated in the job and guaranteed by its suppliers or manufacturers.

We agree that this guarantee and the rights and obligations accruing there from shall be in addition and not by way of limitation in any manner whatsoever to the rights, obligations, warranties or remedies otherwise provided for by law.

In the event of our failure to comply with the above mentioned conditions with ten (10) days after being notified in writing by the County of El Dorado, we hereby authorize the County of El Dorado to proceed to have said defects repaired and made good at our expense and we will honor and pay all costs and charges therefore upon written demand.

EXECUTED on this \_\_\_\_\_ day of \_\_\_\_\_, 2019.

CONTRACTOR

By \_\_\_\_\_

Title \_\_\_\_\_

By \_\_\_\_\_

Title \_\_\_\_\_

**\* END OF CONTRACTORS GUARANTEE \***

**COUNTY OF EL DORADO**

**PAYMENT BOND**

(Section 3247, Civil Code)

Bond No. \_\_\_\_\_

WHEREAS, the County of El Dorado, a political subdivision of the State of California, hereafter referred to as "Obligee", has awarded to Contractor

\_\_\_\_\_ hereafter referred to as "Principal", a contract for the work described as follows:

**SOUTH LAKE TAHOE (SLT)  
HEALTH & HUMAN SERVICES AGENCY (HHS)  
TENANT IMPROVEMENT PROJECT  
BID #19-968-041**

AND, WHEREAS, said Principal is required to furnish a bond in connection with said contract, guaranteeing the faithful performance thereof:

NOW, THEREFORE, we the undersigned Principal and Surety are held and firmly bound unto the Obligee, in the sum of \_\_\_\_\_ Dollars, (\$ \_\_\_\_\_) to be paid to the Obligee, for which payment we bind ourselves, jointly and severally.

**THE CONDITION OF THIS OBLIGATION IS SUCH,**

That if said Principal or its subcontractors shall fail to pay any of the persons named in Civil Code Section 3181, or amounts due under the Unemployment Insurance Code with respect to work or labor performed by such claimant, or any amounts required to be deducted, withheld, and paid over to the Franchise Tax Board from the wages of employees of the Principal and his subcontractors pursuant to Section 18806 of the Revenue and Taxation Code, with respect to such work and labor, that the Surety herein will pay for the same in an amount not exceeding the sum specified in this bond, otherwise the above obligation shall be void. In case suit is brought upon this bond, the Surety will pay a reasonable attorney's fee to be fixed by the court.

This bond shall inure to the benefit of any of the persons named in Civil Code Section 3181 as to give a right of action to such persons or their assigns in any suit brought upon this bond.

Dated: \_\_\_\_\_

Correspondence or Claims relating to this bond should be sent to the Surety at the following address:

\_\_\_\_\_  
\_\_\_\_\_  
\_\_\_\_\_

\_\_\_\_\_  
PRINCIPAL  
\_\_\_\_\_  
SURETY  
\_\_\_\_\_  
ATTORNEY-IN-FACT

NOTE: Signatures of those executing for the Principal and for the Surety must be properly acknowledged, and a Power of Attorney attached for the Surety.

**NOTARY ACKNOWLEDGMENTS ATTACHED**

**PRINCIPAL**

A notary public or other officer completing this certificate verifies only the identity of the individual who signed the document to which this certificate is attached, and not the truthfulness, accuracy, or validity of that document.

**ACKNOWLEDGMENT**

State of California

County of \_\_\_\_\_

On \_\_\_\_\_ before me, \_\_\_\_\_,  
(here insert name and title of the officer)

personally appeared \_\_\_\_\_

\_\_\_\_\_

\_\_\_\_\_ ,

who proved to me on the basis of satisfactory evidence to be the person(s) whose name(s) is/are subscribed to the within instrument and acknowledged to me that he/she/they executed the same in his/her/their authorized capacity(ies), and that by his/her/their signature(s) on the instrument the person(s), or the entity upon behalf of which the person(s) acted, executed the instrument.

I certify under PENALTY OF PERJURY under the laws of the State of California that the foregoing paragraph is true and correct.

WITNESS my hand and official seal.

Signature \_\_\_\_\_

(Seal)

# SURETY

A notary public or other officer completing this certificate verifies only the identity of the individual who signed the document to which this certificate is attached, and not the truthfulness, accuracy, or validity of that document.

## ACKNOWLEDGMENT

State of California

County of \_\_\_\_\_

On \_\_\_\_\_ before me, \_\_\_\_\_,  
(here insert name and title of the officer)

personally appeared \_\_\_\_\_  
\_\_\_\_\_  
\_\_\_\_\_ ,

who proved to me on the basis of satisfactory evidence to be the person(s) whose name(s) is/are subscribed to the within instrument and acknowledged to me that he/she/they executed the same in his/her/their authorized capacity(ies), and that by his/her/their signature(s) on the instrument the person(s), or the entity upon behalf of which the person(s) acted, executed the instrument.

I certify under PENALTY OF PERJURY under the laws of the State of California that the foregoing paragraph is true and correct.

WITNESS my hand and official seal.

Signature \_\_\_\_\_

(Seal)

**COUNTY OF EL DORADO**

**PERFORMANCE BOND**

Bond No. \_\_\_\_\_

KNOW ALL MEN BY THESE PRESENTS, that we \_\_\_\_\_

the Contractor in the Contract hereto annexed, as Principal, and \_\_\_\_\_

as Surety, are held firmly bound unto the County of El Dorado, a political subdivision of the State of California, hereinafter

called the "Obligee" in the sum of \_\_\_\_\_ DOLLARS,

(\$ \_\_\_\_\_ ) lawful money of the United States, for which payment, well and truly to be made, we

bind ourselves, jointly and severally, firmly by these presents.

Signed, sealed and dated: \_\_\_\_\_

The condition of the above obligation is such that if said Principal as Contractor in the Contract hereto annexed shall faithfully perform each and all of the conditions of said Contract to be performed by him, and shall furnish all tools, equipment, apparatus, facilities, transportation, labor and material, other than material, if any, agreed to be furnished by the Obligee, necessary to perform and complete, and to perform and complete in a good and workmanlike manner, the work of **BID #19-968-041 for the SOUTH LAKE TAHOE (SLT) HEALTH & HUMAN SERVICES AGENCY (HSA) TENANT IMPROVEMENT PROJECT** in strict conformity with the terms and conditions set forth in the Contract hereto annexed, then this obligation shall be null and void; otherwise this bond shall remain in full force and effect and the said Surety will complete the Contract work under its own supervision, by Contract or otherwise, and pay all costs thereof for the balance due under terms of the Contract, and the said Surety, for value received, hereby stipulates and agrees that no change, extension of time, alteration or addition to the terms of the Contract or to the work to be performed thereunder shall in any wise affect its obligation on this bond, and it does hereby waive notice of any such change, extension of time, alteration or addition to the terms of the Contract or to the work.

In the event suit is brought upon this bond by the Obligee and judgment is recovered, the Surety shall pay all costs incurred by the Obligee in such suit, including a reasonable attorney's fee to be fixed by the court.

This guarantee shall insure the Obligee during the work required by any Contract and for a period of one (1) year from the date of acceptance of the work against faulty or improper materials or workmanship that may be discovered during that time.

No right of action shall accrue under this bond to or for the use of any person other than the Obligee named herein.

Dated: \_\_\_\_\_, 20\_\_\_\_\_.

Correspondence or Claims relating to this bond should be sent to the Surety at the following address:

\_\_\_\_\_

\_\_\_\_\_

\_\_\_\_\_

\_\_\_\_\_

PRINCIPAL

\_\_\_\_\_

SURETY

\_\_\_\_\_

ATTORNEY-IN-FACT

NOTE: Signatures of those executing for the Principal and the Surety must be properly acknowledged, and a Power of Attorney attached for the Surety.

**NOTARY ACKNOWLEDGMENTS ATTACHED**

**PRINCIPAL**

A notary public or other officer completing this certificate verifies only the identity of the individual who signed the document to which this certificate is attached, and not the truthfulness, accuracy, or validity of that document.

**ACKNOWLEDGMENT**

State of California

County of \_\_\_\_\_

On \_\_\_\_\_ before me, \_\_\_\_\_,  
(here insert name and title of the officer)

personally appeared \_\_\_\_\_  
\_\_\_\_\_  
\_\_\_\_\_ ,

who proved to me on the basis of satisfactory evidence to be the person(s) whose name(s) is/are subscribed to the within instrument and acknowledged to me that he/she/they executed the same in his/her/their authorized capacity(ies), and that by his/her/their signature(s) on the instrument the person(s), or the entity upon behalf of which the person(s) acted, executed the instrument.

I certify under PENALTY OF PERJURY under the laws of the State of California that the foregoing paragraph is true and correct.

WITNESS my hand and official seal.

Signature \_\_\_\_\_

(Seal)



# SURETY

A notary public or other officer completing this certificate verifies only the identity of the individual who signed the document to which this certificate is attached, and not the truthfulness, accuracy, or validity of that document.

## ACKNOWLEDGMENT

State of California

County of \_\_\_\_\_

On \_\_\_\_\_ before me, \_\_\_\_\_,  
(here insert name and title of the officer)

personally appeared \_\_\_\_\_

\_\_\_\_\_  
\_\_\_\_\_ ,

who proved to me on the basis of satisfactory evidence to be the person(s) whose name(s) is/are subscribed to the within instrument and acknowledged to me that he/she/they executed the same in his/her/their authorized capacity(ies), and that by his/her/their signature(s) on the instrument the person(s), or the entity upon behalf of which the person(s) acted, executed the instrument.

I certify under PENALTY OF PERJURY under the laws of the State of California that the foregoing paragraph is true and correct.

WITNESS my hand and official seal.

Signature \_\_\_\_\_

(Seal)

**2015 Withholding Exemption Certificate****590****The payee completes this form and submits it to the withholding agent.****Withholding Agent** (Type or print)

Name \_\_\_\_\_

**Payee**Name \_\_\_\_\_  SSN or ITIN  FEIN  CA Corp no.  CA SOS file no.

Address (apt./ste., room, PO Box, or PMB no.) \_\_\_\_\_

City (If you have a foreign address, see instructions.) \_\_\_\_\_

State \_\_\_\_\_

ZIP Code \_\_\_\_\_

**Exemption Reason**

Check only one reason box below that applies to the payee.

By checking the appropriate box below, the Payee certifies the reason for the exemption from the California income tax withholding requirements on payment(s) made to the entity or individual.

 **Individuals — Certification of Residency:**

I am a resident of California and I reside at the address shown above. If I become a nonresident at any time, I will promptly notify the withholding agent. See instructions for General Information D, Definitions.

 **Corporations:**

The corporation has a permanent place of business in California at the address shown above or is qualified through the California Secretary of State (SOS) to do business in California. The corporation will file a California tax return. If this corporation ceases to have a permanent place of business in California or ceases to do any of the above, I will promptly notify the withholding agent. See instructions for General Information D, Definitions.

 **Partnerships or Limited Liability Companies (LLCs):**

The partnership or LLC has a permanent place of business in California at the address shown above or is registered with the California SOS, and is subject to the laws of California. The partnership or LLC will file a California tax return. If the partnership or LLC ceases to do any of the above, I will promptly inform the withholding agent. For withholding purposes, a limited liability partnership (LLP) is treated like any other partnership.

 **Tax-Exempt Entities:**

The entity is exempt from tax under California Revenue and Taxation Code (R&amp;TC) Section 23701 \_\_\_\_\_ (insert letter) or Internal Revenue Code Section 501(c) \_\_\_\_\_ (insert number). If this entity ceases to be exempt from tax, I will promptly notify the withholding agent. Individuals cannot be tax-exempt entities.

 **Insurance Companies, Individual Retirement Arrangements (IRAs), or Qualified Pension/Profit Sharing Plans:**

The entity is an insurance company, IRA, or a federally qualified pension or profit-sharing plan.

 **California Trusts:**

At least one trustee and one noncontingent beneficiary of the above-named trust is a California resident. The trust will file a California fiduciary tax return. If the trustee or noncontingent beneficiary becomes a nonresident at any time, I will promptly notify the withholding agent.

 **Estates — Certification of Residency of Deceased Person:**

I am the executor of the above-named person's estate or trust. The decedent was a California resident at the time of death. The estate will file a California fiduciary tax return.

 **Nonmilitary Spouse of a Military Servicemember:**

I am a nonmilitary spouse of a military servicemember and I meet the Military Spouse Residency Relief Act (MSRRA) requirements. See instructions for General Information E, MSRRA.

**CERTIFICATE OF PAYEE:** Payee must complete and sign below.

Under penalties of perjury, I hereby certify that the information provided in this document is, to the best of my knowledge, true and correct. If conditions change, I will promptly notify the withholding agent.

Payee's name and title (type or print) \_\_\_\_\_ Telephone (\_\_\_\_) \_\_\_\_\_

Payee's signature ► \_\_\_\_\_ Date \_\_\_\_\_

# 2015 Instructions for Form 590

## Withholding Exemption Certificate

References in these instructions are to the California Revenue and Taxation Code (R&TC).

### General Information

**Registered Domestic Partners (RDP)** – For purposes of California income tax, references to a spouse, husband, or wife also refer to a Registered Domestic Partner (RDP) unless otherwise specified. For more information on RDPs, get FTB Pub. 737, Tax Information for Registered Domestic Partners.

### A Purpose

Use Form 590, Withholding Exemption Certificate, to certify an exemption from nonresident withholding.

Form 590 does not apply to payments of backup withholding. For information on California backup withholding, go to [ftb.ca.gov](http://ftb.ca.gov) and search for **backup withholding**.

Form 590 does not apply to payments for wages to employees. Wage withholding is administered by the California Employment Development Department (EDD). For more information, go to [edd.ca.gov](http://edd.ca.gov) or call 888.745.3886.

**Do not** use Form 590 to certify an exemption from withholding if you are a **Seller of California real estate**. Sellers of California real estate use Form 593-C, Real Estate Withholding Certificate, to claim an exemption from real estate withholding.

**The following are excluded from withholding and completing this form:**

- The United States and any of its agencies or instrumentalities.
- A state, a possession of the United States, the District of Columbia, or any of its political subdivisions or instrumentalities.
- A foreign government or any of its political subdivisions, agencies, or instrumentalities.

### B Income Subject to Withholding

California Revenue and Taxation Code (R&TC) Section 18662 requires withholding of income or franchise tax on payments of California source income made to nonresidents of California.

Withholding is required on the following, but is not limited to:

- Payments to nonresidents for services rendered in California.
- Distributions of California source income made to domestic nonresident partners, members, and S corporation shareholders and allocations of California source income made to foreign partners and members.
- Payments to nonresidents for rents if the payments are made in the course of the withholding agent's business.

- Payments to nonresidents for royalties from activities sourced to California.
- Distributions of California source income to nonresident beneficiaries from an estate or trust.
- Endorsement payments received for services performed in California.
- Prizes and winnings received by nonresidents for contests in California.

However, withholding is optional if the total payments of California source income are \$1,500 or less during the calendar year.

For more information on withholding get FTB Pub. 1017, Resident and Nonresident Withholding Guidelines. To get a withholding publication, see Additional Information.

### C Who Certifies this Form

Form 590 is certified by the payee. California residents or entities exempt from the withholding requirement should complete Form 590 and submit it to the withholding agent before payment is made. The withholding agent is then relieved of the withholding requirements if the agent relies in good faith on a completed and signed Form 590 unless notified by the Franchise Tax Board (FTB) that the form should not be relied upon.

An incomplete certificate is invalid and the withholding agent should not accept it. If the withholding agent receives an incomplete certificate, the withholding agent is required to withhold tax on payments made to the payee until a valid certificate is received. In lieu of a completed certificate on the preprinted form, the withholding agent may accept as a substitute certificate a letter from the payee explaining why the payee is not subject to withholding. The letter must contain all the information required on the certificate in similar language, including the under penalty of perjury statement and the payee's taxpayer identification number. The withholding agent must retain a copy of the certificate or substitute for at least four years after the last payment to which the certificate applies, and provide it upon request to the FTB.

For example, if an entertainer (or the entertainer's business entity) is paid for a performance, the entertainer's information must be provided. **Do not** submit the entertainer's agent or promoter information.

The grantor of a grantor trust shall be treated as the payee for withholding purposes. Therefore, if the payee is a grantor trust and one or more of the grantors is a nonresident, withholding is required. If all of the grantors on the trust are residents, no withholding is required. Resident grantors can check the box on Form 590 labeled "Individuals — Certification of Residency."

### D Definitions

For California non-wage withholding purposes, **nonresident** includes all of the following:

- Individuals who are not residents of California.
- Corporations not qualified through the California Secretary of State (CA SOS) to do business in California or having no permanent place of business in California.
- Partnerships or limited liability companies (LLCs) with no permanent place of business in California.
- Any trust without a resident grantor, beneficiary, or trustee, or estates where the decedent was not a California resident.

Foreign refers to non-U.S.

For more information about determining resident status, get FTB Pub. 1031, Guidelines for Determining Resident Status. Military servicemembers have special rules for residency. For more information, get FTB Pub. 1032, Tax Information for Military Personnel.

#### Permanent Place of Business:

A corporation has a permanent place of business in California if it is organized and existing under the laws of California or if it is a foreign corporation qualified to transact intrastate business by the CA SOS. A corporation that has not qualified to transact intrastate business (e.g., a corporation engaged exclusively in interstate commerce) will be considered as having a permanent place of business in California only if it maintains a permanent office in California that is permanently staffed by its employees.

### E Military Spouse Residency Relief Act (MSRRA)

Generally, for tax purposes you are considered to maintain your existing residence or domicile. If a military servicemember and nonmilitary spouse have the same state of domicile, the MSRRA provides:

- A spouse shall not be deemed to have lost a residence or domicile in any state solely by reason of being absent to be with the servicemember serving in compliance with military orders.
- A spouse shall not be deemed to have acquired a residence or domicile in any other state solely by reason of being there to be with the servicemember serving in compliance with military orders.

**Domicile** is defined as the one place:

- Where you maintain a true, fixed, and permanent home.
- To which you intend to return whenever you are absent.

A military servicemember's nonmilitary spouse is considered a nonresident for tax purposes if the servicemember and spouse have the same domicile outside of California and the spouse is in California solely to be with the servicemember who is serving in compliance with Permanent Change of Station orders.

California may require nonmilitary spouses of military servicemembers to provide proof that they meet the criteria for California personal income tax exemption as set forth in the MSRRRA.

Income of a military servicemember's nonmilitary spouse for services performed in California is not California source income subject to state tax if the spouse is in California to be with the servicemember serving in compliance with military orders, and the servicemember and spouse have the same domicile in a state other than California.

For additional information or assistance in determining whether the applicant meets the MSRRRA requirements, get FTB Pub. 1032.

## Specific Instructions

### Payee Instructions

Enter the withholding agent's name.

Enter the payee's information, including the taxpayer identification number (TIN) and check the appropriate TIN box.

You must provide an acceptable TIN as requested on this form. The following are acceptable TINs: social security number (SSN); individual taxpayer identification number (ITIN); federal employer identification number (FEIN); California corporation number (CA Corp no.); or CA SOS file number.

**Private Mail Box (PMB)** – Include the PMB in the address field. Write "PMB" first, then the box number. Example: 111 Main Street PMB 123.

**Foreign Address** – Enter the information in the following order: City, Country, Province/Region, and Postal Code. Follow the country's practice for entering the postal code. **Do not** abbreviate the country's name.

Check the box that reflects the reason why the payee is exempt from the California income tax withholding requirement.

### Withholding Agent Instructions

Keep Form 590 for your records. **Do not** send this form to the FTB unless it has been specifically requested.

For more information, contact Withholding Services and Compliance, see Additional Information.

The payee must notify the withholding agent if any of the following situations occur:

- The individual payee becomes a nonresident.
- The corporation ceases to have a permanent place of business in California or ceases to be qualified to do business in California.
- The partnership ceases to have a permanent place of business in California.
- The LLC ceases to have a permanent place of business in California.
- The tax-exempt entity loses its tax-exempt status.

If any of these situations occur, then withholding may be required. For more information, get Form 592, Resident and Nonresident Withholding Statement, Form 592-B, Resident and Nonresident Withholding Tax Statement, and Form 592-V, Payment Voucher for Resident and Nonresident Withholding.

## Additional Information

For additional information or to speak to a representative regarding this form, call the Withholding Services and Compliance telephone service at:

Telephone: **888.792.4900**  
916.845.4900

Fax: 916.845.9512

OR write to:

WITHHOLDING SERVICES AND  
COMPLIANCE MS F182  
FRANCHISE TAX BOARD  
PO BOX 942867  
SACRAMENTO CA 94267-0651

You can download, view, and print California tax forms and publications at **ftb.ca.gov**.

OR to get forms by mail write to:

TAX FORMS REQUEST UNIT  
FRANCHISE TAX BOARD  
PO BOX 307  
RANCHO CORDOVA CA 95741-0307

For all other questions unrelated to withholding or to access the TTY/TDD numbers, see the information below.

### Internet and Telephone Assistance

Website: **ftb.ca.gov**

Telephone: 800.852.5711 from within the  
United States  
916.845.6500 from outside the  
United States

TTY/TDD: 800.822.6268 for persons with  
hearing or speech impairments

### Asistencia Por Internet y Teléfono

Sitio web: **ftb.ca.gov**

Teléfono: 800.852.5711 dentro de los  
Estados Unidos  
916.845.6500 fuera de los Estados  
Unidos

TTY/TDD: 800.822.6268 para personas con  
discapacidades auditivas  
o del habla



# County of El Dorado

OFFICE OF AUDITOR-CONTROLLER

360 FAIR LANE  
PLACERVILLE, CALIFORNIA 95667  
Phone: (530) 621-5487 FAX: (530) 295-2535

JOE HARN, CPA  
Auditor-Controller

BOB TOSCANO  
Assistant Auditor-Controller

## PAYEE DATA RECORD

(Required in lieu of IRS W-9 when receiving payment from the County of El Dorado) Version: April 2014

PAYEE DATA RECORD	<b>INSTRUCTIONS:</b> Complete all information on this form. Sign, date, and return to the address shown at the bottom of this page. Prompt return of the <b>fully completed</b> form will prevent delays in processing payments. Information provided in this form will be used by the County of El Dorado to prepare Information Returns (Forms 1099), for withholding on payments to nonresident payees, and for reporting to the Employment Development Department (EDD).									
	Name (as shown on your income tax return)									
	Business name/Doing business as/Disregarded entity name, if different from above									
	Physical address (number, street, and apt. or suite)					Remittance address (if different than physical)				
	City, state, zip code					City, state, zip code				
NAME AND ADDRESS	Phone number			Fax number (optional)			Email (optional)			
	<b>Check appropriate federal tax classification</b>									
	<input type="checkbox"/> Individual / sole proprietor <input type="checkbox"/> Partnership <input type="checkbox"/> Trust / estate <input type="checkbox"/> Other (see instructions) ▶ _____									
	<input type="checkbox"/> C Corporation <input type="checkbox"/> S Corporation            If you are a corporation, do you provide legal or medical services? <input type="checkbox"/> Yes <input type="checkbox"/> No									
	<input type="checkbox"/> Limited liability company. Enter the tax classification (C=C Corporation, S=S Corporation, P=Partnership) _____									
FEDERAL TAX CLASSIFICATION & EXEMPTIONS	<b>NOTE: IF YOU ARE A SINGLE MEMBER LLC (DISREGARDED ENTITY), ENTER THE TAX CLASSIFICATION OF THE OWNER IDENTIFIED ON THE NAME LINE.</b>									
	Exempt payee code (if any) – see instructions _____					Exemption from FATCA reporting code (if any) – see instructions _____				
TAX IDENTIFICATION NUMBER	<b>Tax identification number (TIN)</b>									
	Enter your TIN in the appropriate box. If you are an individual or sole proprietor, you must enter your SSN. You may choose to provide your EIN in addition to, but not instead of, the SSN. Single member LLCs (disregarded entities) must enter the TIN of the owner identified on the Name line.						Social Security Number			
							Employer Identification Number			
RESIDENCY STATUS	<b>Check appropriate box for residency status</b>									
	<input type="checkbox"/> California resident / exempt from nonresident withholding – qualified to do business in California or maintains a permanent place of business in California (attach CA Form 590)									
	<input type="checkbox"/> California nonresident (see instructions)									
	<b>NOTE:</b> Payments to California <b>nonresidents</b> for services performed in California and for certain rents derived from properties located in California that exceed \$1,500 in a calendar year will be subject to 7% nonresident withholding unless you have obtained a waiver or have been approved for reduced withholding by the Franchise Tax Board. There is no withholding on payments for product and for services performed outside of California.									
	<input type="checkbox"/> Obtained Franchise Tax Board waiver of State withholding (attach a copy if applicable) <input type="checkbox"/> Obtained Franchise Tax Board approval for reduced withholding (attach a copy if applicable)									
California sales tax permit number										
(required only for California nonresident vendors that charge California sales tax)										
CERTIFICATION	<b>Under penalties of perjury, I certify that:</b>									
	1) the TIN shown on this form is my correct taxpayer identification number (or I am waiting for a number to be issued to me) <b>and</b>									
	2) I am not subject to backup withholding <b>and</b> 3) I am a U.S. citizen or other U.S. person <b>and</b> 4) the FATCA code(s) entered on this form (if any) indicating that I am exempt from FATCA reporting is correct.									
	Authorized Payee Representative's Name (Type or Print)						Title			
Signature			Date			Telephone				
Should my residency status or any other information provided above change, I will promptly notify County of El Dorado at the address listed above.										
RETURN FORM TO	Please return completed form to:									
	Department/office:									
	Mailing address:									
	Phone:		Fax:		Email:		18-1912 Revised B 45 of 606			
BOS Rcvd 1-24-19										

COUNTY OF EL DORADO, PAYEE DATA RECORD (REVERSE)

<p><b>PAYEE DATA RECORD</b></p>	<p>A completed Payee Data Record is required for payments to all entities and will be kept on file at the County of El Dorado Auditor-Controller's Office. Payees who do not wish to complete the Payee Data Record may elect to not do business with the County of El Dorado. If the payee does not complete the form and the required payee data is not otherwise provided, payment may be reduced for federal backup withholding, California backup withholding and California nonresident withholding.</p>
<p><b>FEDERAL TAX CLASSIFICATION</b></p>	<p>Check the applicable federal tax classification. Note that if an LLC is disregarded as an entity separate from its owner, enter the appropriate tax classification of the owner identified on the "Name" line.</p> <p><b>Individual:</b> Enter the name shown on your income tax return. If the account is in joint names, list first, and then circle, the name of the person or entity whose SSN you entered on the form.</p> <p><b>Sole proprietor:</b> Enter your individual name as shown on your income tax return on the "Name" line. You may enter your business, trade, or "doing business as" name on the "Business name/Doing business as/Disregarded entity name" line.</p> <p><b>Partnership, C Corporation, or S Corporation:</b> Enter the entity's name on the "Name" line and any business, trade, or "doing business as" name on the "Business name/Doing business as/Disregarded entity name" line.</p> <p><b>Disregarded entity:</b> Enter the owner's name on the "Name" line. The name of the entity entered on the "Name" line should never be a disregarded entity. The name on the "Name" line must be the name shown on the income tax return on which the income should be reported. Check the appropriate box for the U.S. federal tax classification of the person whose name is entered on the "Name" line (individual/sole proprietor, partnership, C corporation, S corporation, trust/estate).</p> <p><b>Limited liability company (LLC):</b> If the person identified on the "Name" line is an LLC, check the "Limited Liability Company" box only and enter the appropriate code for the U.S. federal tax classification.</p> <p><b>Other entities:</b> Enter your business name as shown on required U.S. federal tax documents on the "Name" line. This name should match the name shown on the charter or other legal document creating the entity. You may enter any business, trade or DBA name on the "Business name/Doing business as/Disregarded entity name" line.</p>
<p><b>EXEMPTIONS</b></p>	<p><b>Exemptions:</b> If you are exempt from backup withholding and/or FATCA reporting, enter in the exemptions box any code(s) that may apply to you. Generally, individuals (including sole proprietors) are not exempt from backup withholding. Corporations are exempt from backup withholding for certain payments, such as interest and dividends. Corporations are not exempt from backup withholding for payments made in settlement of payment card or third party network transactions. The following codes identify payees that are exempt from backup withholding: <b>1</b> – an organization exempt from tax under section 501(a), any IRA, or a custodial account under section 403(b)(7) if the account satisfies the requirements of section 401(f)(2); <b>2</b> – The United States or any of its agencies or instrumentalities; <b>3</b> – A state, the District of Columbia, a possession of the United States, or any of their political subdivisions or instrumentalities; <b>4</b> – A foreign government or any of its political subdivisions, agencies, or instrumentalities; <b>5</b> – A corporation; <b>6</b> – A dealer in securities or commodities required to register in the United States, the District of Columbia, or a possession of the United States; <b>7</b> – A futures commission merchant registered with the Commodity Futures Trading Commission; <b>8</b> – A real estate investment fund; <b>9</b> – An entity registered at all times during the tax year under the Investment Company Act of 1940; <b>10</b> – A common trust fund operated by a bank under section 584(a); <b>11</b> – A financial institution; <b>12</b> – A middleman known in the investment community as a nominee or custodian; <b>13</b> – A trust exempt from tax under section 664 or described in section 4947.</p> <p><b>Exemption from FATCA reporting.</b> The following codes identify payees that are exempt from reporting under FATCA. These codes apply to persons submitting this form for accounts maintained outside of the United States by certain foreign financial institutions. Therefore, if you are only submitting this form for an account you hold in the United States, you may leave this field blank. Consult with the person requesting this form if you are uncertain if the financial institution is subject to these requirements. <b>A</b>—An organization exempt from tax under section 501(a) or any individual retirement plan as defined in section 7701(a)(37); <b>B</b>—The United States or any of its agencies or instrumentalities; <b>C</b>—A state, the District of Columbia, a possession of the United States, or any of their political subdivisions or instrumentalities; <b>D</b>—A corporation the stock of which is regularly traded on one or more established securities markets, as described in Reg. section 1.1472-1(c)(1)(i); <b>E</b>—A corporation that is a member of the same expanded affiliated group as a corporation described in Reg. section 1.1472-1(c)(1)(i); <b>F</b>—A dealer in securities, commodities, or derivative financial instruments (including notional principal contracts, futures, forwards, and options) that is registered as such under the laws of the United States or any state.</p>
<p><b>TAX IDENTIFICATION NUMBER</b></p>	<p>Enter your tax identification number (TIN) in the appropriate box. If you are a single member LLC that is disregarded as an entity separate from its owner, enter the owner's SSN (or EIN, if the owner has one). Do not enter the disregarded entity's EIN. If the LLC is classified as a corporation or partnership, enter the entity's EIN. <b>The TIN for individuals and sole proprietors is the Social Security Number (SSN).</b> Sole proprietors may provide their EIN in addition to but not instead of a SSN.</p> <p>The County of El Dorado requires that all parties entering into business transactions that may lead to payment(s) from the County provide their Taxpayer Identification Number (TIN). The TIN is also required by the California Revenue and Taxation Code Section 18646 to facilitate tax compliance enforcement activities and the preparation of Form 1099 and other information returns as required by the Internal Revenue Code Section 6109(a).</p>
<p><b>RESIDENCY STATUS</b></p>	<p><b>Are you a California resident or nonresident?</b></p> <p>A <b>corporation</b> will be defined as a "resident" if it has a permanent place of business in California or is qualified through the Secretary of State to do business in California. A <b>partnership</b> is considered a resident partnership if it has a permanent place of business in California. An <b>estate</b> is a resident if the decedent was a California resident at time of death. A <b>trust</b> is a resident if at least one trustee is a California resident. For <b>individuals and sole proprietors</b>, the term "resident" includes every individual who is in California for other than a temporary or transitory purpose and any individual domiciled in California who is absent for a temporary or transitory purpose. Generally, an individual who comes to California for a purpose that will extend over a long or indefinite period will be considered a resident. However, an individual who comes to perform a particular contract of short duration will be considered a nonresident.</p> <p><b>Payments to all nonresidents may be subject to withholding.</b> Nonresident payees performing services in California or receiving certain rent, lease, or royalty payments from property (real or personal) located in California will have 7% of their total payments withheld for State income taxes. However, no withholding is required if total payments to the payee are \$1,500 or less for the calendar year or if payment is for product. Nonresidents who have been granted a waiver on payments of California source income from the California Franchise Tax Board must submit a copy of the waiver. For information on Nonresident Withholding, contact the Franchise Tax Board at the numbers listed below:</p> <p style="text-align: center;">Withholding Services and Compliance Section:      1-888-792-4900      E-mail address:      wscs.gen@ftb.ca.gov      For hearing impaired with TDD, call:      1-800-822-6268      Website:      www.ftb.ca.gov</p> <p>California nonresidents charging California sales tax are required to provide their California sales tax number.</p>
<p><b>CERTIFICATION</b></p>	<p>Provide the name, title, signature, and telephone number of the authorized individual completing this form. Provide the date the form was completed. <b>NOTE:</b> You must cross out item 2 in the certification block if you have been notified by the IRS that you are currently subject to backup withholding because you have failed to report all interest and dividends on your tax return.</p>

**CERTIFICATE OF INSURANCE FORM FOR CONTRACTORS, ARCHITECTS AND/OR ENGINEERS**

CERTIFICATE ISSUER  PHONE ( )	DATE EXECUTED:  THIS CERTIFICATE DOES NOT AMEND, EXTEND, OR ALTER THE COVERAGE AFFORDED BY THE POLICIES BELOW. COMPANIES AFFORDING COVERAGE		
INSURED  PHONE ( )	COMPANY A LETTER  COMPANY B LETTER  COMPANY C LETTER  COMPANY D LETTER  COMPANY E LETTER	COMPANY RATING  COMPANY RATING  COMPANY RATING  COMPANY RATING  COMPANY RATING	
PROJECT DESCRIPTION  PROJECT TITLE:  PROJECT NUMBER:  LOCATION:			

THIS IS TO CERTIFY that policies of insurance listed below have been issued to the insured named above for the policy period indicated. Notwithstanding any requirement, term or condition of any contract or other document with respect to which this certificate may be issued or may pertain, the insurance afforded by the policies described herein is subject to all the terms, exclusion and conditions of such policies.

CL	Type of Insurance Coverage	Policy Number	Policy Effective Date	Policy Expiration Date	Limits of Liability (in Thousands)
	GENERAL LIABILITY <input type="checkbox"/> Commercial General Liability <input type="checkbox"/> Occurrence <input type="checkbox"/> Claims Made <input type="checkbox"/> Owner's & Contractor's Protective <input type="checkbox"/> General Aggregate * <input type="checkbox"/> Per Project <input type="checkbox"/> Per Location				GENERAL AGGREGATE \$ PRODUCTS-COMP/OPS AGGREGATE \$ PERSONAL & ADVERTISING INJURY \$ EACH OCCURRENCE \$ FIRE DAMAGE (ANY ONE FIRE) \$ MEDICAL EXPENSES (ANY ONE PERSON) \$ DEDUCTIBLE \$
	ARCHITECT'S AND/OR ENGINEER'S PROFESSIONAL LIABILITY <input type="checkbox"/> Claims Made <input type="checkbox"/> Project				GENERAL AGGREGATE \$ EACH CLAIM \$  DEDUCTIBLE \$
	AUTOMOBILE LIABILITY <input type="checkbox"/> Any Auto <input type="checkbox"/> All Owned Autos <input type="checkbox"/> Scheduled Autos <input type="checkbox"/> Hired Autos <input type="checkbox"/> Non-Owned Autos <input type="checkbox"/> Garage Liability				COMBINED SINGLE LIMIT \$ BODILY INJURY (PER PERSON) \$ BODILY INJURY (PER ACCIDENT) \$ PROPERTY DAMAGE \$ DEDUCTIBLE \$
	EXCESS LIABILITY <input type="checkbox"/> Umbrella Form <input type="checkbox"/> Other Than Umbrella Form				EACH OCCURRENCE \$ AGGREGATE \$
	<input type="checkbox"/> WORKER'S COMPENSATION				-----STATUTORY-----
	EMPLOYER'S LIABILITY				(EACH ACCIDENT) \$ (DISEASE - POLICY LIMIT) \$ (DISEASE - EACH EMPLOYEE) \$
	OTHER <input type="checkbox"/> Installation Floater <input type="checkbox"/> Builder's Risk <input type="checkbox"/>				\$ \$ \$

\* The General Aggregate limit, under Limits of Insurance, applies separately to each of the projects away from premises owned by or rented by you.

DESCRIPTION OF OPERATIONS/LOCATIONS/VEHICLES/SPECIAL ITEMS/ADDITIONAL INSURED: The County of El Dorado its officers, officials, employees and volunteers are made additional insured, but only insofar as the operations under this contract are concerned. OTHER ADDITIONAL ISSURED:
---

CERTIFICATE HOLDER	SHOULD ANY OF THE ABOVE DESCRIBED POLICIES BE CANCELLED OR TERMINATED BEFORE THE EXPIRATION DATE THEREOF, THE ISSUING COMPANY WILL GIVE THIRTY (30) DAYS WRITTEN NOTICE TO THE CERTIFICATE HOLDER NAMED TO THE LEFT, IN ADVANCE OF THE EFFECTIVE DATE OF SUCH CANCELLATION OR TERMINATION.  AUTHORIZED REPRESENTATIVE SIGNATURE, TITLE, TYPED NAME, SSN AND PHONE NUMBER:
--------------------	---

**COUNTY OF EL DORADO**  
**SOUTH LAKE TAHOE (SLT**  
**HEALTH & HUMAN SERVICES AGENCY (HHS)**  
**TENANT IMPROVEMENT PROJECT**

**BID #19-968-041**

**CONDITIONS OF THE CONTRACT**

**ARTICLE 1**

**GENERAL PROVISIONS**

**1.1 BASIC DEFINITIONS**

- 1.1.1 **County:** The County of El Dorado, a political subdivision of the State of California.
- 1.1.2 **Owner:** The County of El Dorado is the Owner and is identified as the Owner in the Contract and these Contract Conditions. The term Owner, and pronouns in place of the same shall mean the County of El Dorado acting by and through its duly authorized representative.
- 1.1.3 **Owner's Representative:** The Chief Administrative Office, Facilities Division Manager, or designated representative.
- 1.1.4 **Architect:** The person holding a valid California State Architect's license, whose firm has been designated within the Contract Documents as the Architect to provide services on the Project. When the Architect is referred to within the Contract Documents and no Architect has in fact been designated, then the matter shall be referred to the County and shall be interpreted as Owner's Representative.
- 1.1.5 **Project Manager:** Project Manager or such other designated representative of the Owner. The Project Manager has such duties and authority as may be set forth in the Contract Documents.
- 1.1.6 **Contractor:** The person or entity identified as such in the Contract and is referred to throughout the Contract Documents as if singular in number. The term Contractor refers to the Contractor or the Contractor's authorized representative.
- 1.1.7 **Inspector:** The individual designated by the Owner as the Inspector as set forth in Paragraph 2.1.2.
- 1.1.8 **Subcontractor:** Those contractors, of whatever tier, furnishing labor or material, or both, for the Work under the Contract with the Contractor.
- 1.1.9 **Substantial Completion:** The stage in the progress of the Work when the Work or designated portion thereof is sufficiently complete in accordance with the Contract Documents so the Owner can occupy or utilize the Work for its intended use.
- 1.1.10 **Final Acceptance:** Conditions upon which the County will accept Work as satisfactorily completed in accordance with the Contract Documents. Requirements include, but are not limited to:
1. All Systems having been tested and accepted as having met requirements of the Contract Documents.



2. One (1) PDF format and one (1) hard copy of all as-builts, manufacturer's product data and maintenance manuals having been submitted by the Contractor and reviewed and accepted by the Owner.
  3. All punch list work, as directed by the Owner, having been completed by the Contractor.
  4. Acceptance of the Work by the Owner.
- 1.1.11 **Final Payment:** The Final Payment shall be the only Payment made to Contractor and shall not be considered to be the payment of any or all of the retention.
- 1.1.12 **Architect's Supplemental Instructions/Instruction Bulletins:** A written order of the Architect and reviewed by the Owner's Representative directing the Contractor to provide supplemental instructions, interpretations, or conduct minor changes in work involving neither extra cost nor extra time and being consistent with the scope and functioning of the project, if applicable.
- 1.1.13 **Construction Change Directive:** A written order issued by the Owner directing a change in the Work and stating a proposed basis for adjustment, if any, of Contract Time or Sum. The Owner may by Change Directive, without invalidating the Contract and without Contractor's agreement, order changes in the Work. This procedure will be used in the absence of agreement between Owner and Contractor, for subsequent inclusion in a Change Order.
- 1.1.14 **Change Order:** A Change Directive signed by the Owner and Contractor stating their agreement upon all of the following: 1) a change in the Work, 2) the amount of the adjustment in the Contract Price, if any, and 3) the extent of the adjustment in the Contract Time, if any.
- 1.1.15 **Contract Documents:** The Contract Documents shall include the documents described in Article 2 of the Contract, including Architect's Supplemental Instructions, Construction Change Directives, and Change Orders.
- 1.1.16 **Work:** The construction and services required by the Contract Documents, including all labor, materials, equipment and services provided or to be provided by the Contractor to fulfill the Contractor's obligations.
- 1.1.17 **Project:** The total construction of the Work performed under the Contract Documents.
- 1.1.18 **Plans:** The graphic and pictorial portions of the Contract Documents, wherever located and whenever issued, showing the design, location and dimensions of the Work, generally including plans, elevations, sections, details, schedules, and diagrams, specifically the plans and specifications for this Project..
- 1.1.19 **Technical Specifications:** That portion of the Contract Documents Division 1 through 26 consisting of the technical written requirements for materials, equipment, construction systems, standards and workmanship for the Work, and performance of related services.
- 1.1.20 **Claim:** A demand or assertion by the Contractor seeking, as a matter of right, adjustment or interpretation of Contract terms, payment of money, extension of time, or other relief with respect to the terms of the Contract. Claims must be made by written notice and shall include a demand for the Owner's decision. The responsibility to substantiate claims and to resolve the claims of subcontractors of whatever tier shall rest with the Contractor.
- 1.1.21 **Work Not Included:** Except for such auxiliary work as shown or specified, or is necessary as part of the construction, the following is NOT included in this contract: Any work shown but marked "Not in Contract" (NIC) or otherwise designated to be done under another contract or by Owner.
- 1.1.22 **Furnish (material):** To supply and deliver to the project ready for installation and in operating condition.

- 1.1.23 **Install (Service or Labor):** To place in final position, complete, anchored, connected, and in operable condition with respect to required codes and/or governing agency requirements.
- 1.1.24 **Provide:** To furnish and install complete. When “Furnish”, “Install”, or “Provide” is stated, “Provide” is implied.
- 1.1.25 **Construct:** To “Furnish” materials to “Install” in final position, complete, anchored, and connected with respect to required codes, requirements, Contract Documents, and details.
- 1.1.26 **Day(s):** All references to “day” or “days” in these Contract Documents shall be defined as calendar-day or calendar-days.
- 1.1.27 **Normal Working Hours:** Includes the hours from 7:30 a.m. to 4:30 p.m. Monday through Friday, except for County holidays.

## **1.2 CONTRACT DOCUMENTS**

- 1.2.1 **One Document:** The Contract Documents are one document and any work shown or mentioned shall be performed or furnished. The Contractor admits and agrees that the Contract Documents exhibit the intent and purpose of the Owner in regard to the Work, and that they are not complete in every detail and are to be considered as showing the purpose and intent only; and Contractor further agrees to furnish all labor or material for any detail that is necessary to carry out the intent and purpose of the Specifications without extra charge.
- 1.2.2 **Misuse of Words or Punctuation:** The misplacement, addition, or omission of any word, letter, or punctuation mark will not in any way change the intent or meaning of the Contract Documents. Any part of the Work, or any article pertaining thereto which is not specifically set forth in these Contract Documents, but which is necessary for the proper completion of the Work, is to be supplied and set in place at the Contractor's expense, the same as if it had been mentioned in these Contract Documents. The Contractor shall furnish all things necessary to make a good and workmanlike job in accordance with the intent and purpose of the Contract Documents.

## **1.3 ASSIGNMENT OF CONTRACT**

- 1.3.1 **Mutual Consent:** Neither party to the Contract shall assign the Contract without the written consent of the other party, nor shall the Contractor assign any moneys due or to become due to him hereunder without the written consent of the Owner.
- 1.3.2 **Assignment Under Anti-Trust Claims:** In accordance with Section 4552 of the California Government Code, and Section 7103 of the Public Contract Code, Contractor and subcontractors shall conform to the following requirements:
1. In entering into a public works contract or a subcontract to supply goods, services, or materials pursuant to a public works contract, Contractor or subcontractors offers and agrees to assign to the Owner all rights, title, and interest in and to all causes of action it may have under Section 4 of the Clayton Act (15 U.S.C Section 15) or under the Cartwright Act, [Chapter 2 (commencing with Section 16700) of Part 2 of Division 7 of the Business and Professions Code], arising from purchases of goods, services, or materials pursuant to the public works contract or the subcontract. This assignment shall be made and become effective at the time the Owner tenders Final Payment to the Contractor, without further acknowledgment by the parties.
  2. If an awarding body or public purchasing body receives, either through judgment or settlement, a monetary recovery for a cause of action assigned under Government Code Sections 4550-4554, the

assignor shall be entitled to receive reimbursement for actual legal costs incurred and may, upon demand, recover from the public body any portion of the recovery, including treble damages, attributable to overcharges that were paid by the assignor but were not paid by the public body as part of the bid price, less the expenses incurred in obtaining that portion of the recovery. Upon demand in writing by the assignor, the assignee shall, within one year from such demand, reassign the cause of action assigned under Government Code Sections 4550-4554 if the assignor has been or may have been injured by the violation of law for which the cause of action arose and (a) the assignee has not been injured thereby, or (b) the assignee declines to file a court action for the cause of action.

#### **1.4 WAIVER OF "COMMON PRACTICE"**

1.4.1 The Contractor shall waive "common practice" and "common usage" as construction criteria wherever the Contract Documents details, plans, technical specifications, governing codes, or ordinances require greater quantity or better quality than common practice or common usage would require.

#### **1.5 EXCESSIVE COSTS**

1.5.1 Failure to Comply with Contract: If Contractor fails to comply with any Contract requirements, including any required coordination with other contractors, and that failure results in additional costs to Owner, then Contractor shall be liable for such additional costs.

1.5.2 Construction Methods: If Contractor's construction methods and techniques result in additional costs to Owner, after notice, such Contractor shall be responsible for cost attributable to his methods and techniques.

### **ARTICLE 2**

#### **OWNER**

##### **2.1 OWNER'S REPRESENTATIVE**

2.1.1 Owner Representative: The Owner will be represented by the Owner's Representative who shall oversee the performance of the Contract on behalf of the Owner.

2.1.2 Owner May Appoint Inspector: Owner shall be entitled to appoint an agent as Inspector who shall see that the performance of the Work is in strict accordance with the Contract Documents on behalf of the Owner.

2.1.3 Communication: In order that the Owner may act upon expert advice and upon good procedure, all communications from the Contractor shall be in writing and will be through said Owner's Representative or Inspector, as the Owner may direct, and all communications and instructions from the Owner to the Contractor will be so routed. The Owner reserves the right to alter this procedure without the consent of the Contractor. All communications not in compliance herewith, shall be considered non-binding on the Owner.

##### **2.2 RIGHTS OF OWNER**

2.2.1 Right to Clean Up: Subject to the strict prohibition against maintaining a nuisance, if a dispute arises between the Contractor, Subcontractors, or separate contractors as to the responsibility under their respective Contracts for maintaining the premises and surrounding area free from waste materials and rubbish the Owner may, but need not, clean up and allocate the cost among those responsible as the Inspector determines to be just.

2.2.2 **Right to Accept Imperfect Work:** If any part or portion of the Work completed under this Contract is defective and not in accordance with the Plans or Contract Documents, and if the imperfection is judged by Owner to be not of sufficient magnitude or importance so as to make the Work unacceptable, then Owner shall have the right and authority to retain such Work but will make such deductions in Contract Price as may be equitable and reasonable. However, Owner does not by this section; waive any other rights provided for herein.

2.2.3 **Right to do Adjacent Work:** The Owner reserves the right to perform construction or operations on the site of the Work. In doing this Owner may use its own forces or award separate contracts in connection with other construction or operations on the site but not covered by the Contract Documents. Contractor shall defend, indemnify, and hold Owner harmless for costs incurred by Owner that are payable to a separate contractor because of delays, improperly timed activities, or defective construction by the Contractor, unless such costs are incurred due to the sole or active negligence of Owner.

2.2.4 **Right to Finish Contractor's Work:** If the Contractor defaults or neglects to carry out all or any part of the Work in accordance with the Contract Documents, the Owner has the right, exercisable solely at Owner's discretion, to commence and continue completion of the Work with diligence and promptness. In such an event, if the Owner's cost to complete to Work exceeds the remaining balance of the Contract with the Contractor, Contractor shall reimburse the Owner for such excess costs.

2.2.5 **Right of Partial Use of Project:** The Owner may occupy or use any completed or partially completed portion of the Work at any stage, upon agreement of Owner and Contractor.

1. Such partial occupancy or use may commence whether or not the portion is substantially complete, provided the Owner and Contractor have accepted in writing the responsibilities assigned to each of them for payments, retainage if any, security, maintenance, heat, utilities, damage to work and insurance, and have agreed in writing concerning the period for correction of the Work and commencement of warranties required by the Contract Documents.
2. Consent of the Contractor to partial occupancy or use shall not be unreasonably withheld.
3. Immediately prior to such partial occupancy or use, the Owner and Contractor shall jointly inspect the area to be occupied or portion of the Work to be used in order to determine and record the condition of the Work.
4. Unless otherwise agreed upon in writing, partial occupancy or use of a portion or portions of the Work shall not constitute acceptance of work not complying with the requirements of the Contract Documents.
5. No claim for acceleration, delay, or hindrance, may be made by Contractor on his own behalf or that of any of his subcontractors, for any delays, accelerations, or hindrances that may arise out of Owner's partial occupancy of the Project.

2.2.6 **Right to Audit:** Contractor shall maintain and make available to the County, State Auditor, or to any of their duly authorized representatives all books, papers, job cost records, detailed cost estimates, claims, and accounts, including payment, property, payroll, personnel, subcontractor records, and financial records related to or which arise out of the Work or under terms of this Contract. Contractor shall maintain such books, records, data and documents in accordance with generally accepted accounting principles and in accordance with these Contract Conditions and federal and state requirements. These books, papers, records, claims, and accounts shall be made available for examination during normal business hours and shall be readily available and accessible at Contractor's principal place of business in California, for audit during normal business hours at such place of business. Contractor shall provide office space, photocopies and other assistance to enable audit or inspection representatives to conduct such audits or inspections. This right to audit books and records directly related to this Contract shall also extend to any first-tier subcontractors employed under this Contract. Contractor shall incorporate this provision in any

subcontract entered into as a result of this Contract and shall require its subcontractors to agree to cooperate with the above-listed agencies by making all appropriate and relevant Project records available to those agencies for audit and copying.

All of Contractor's books, papers, job cost records, detailed cost estimates, claims, and accounts, including payment, property, payroll, personnel, subcontractor records, and financial records related to or which arise out of the work or under terms of this Contract shall be retained for access, inspection and/or audit by the County, the State Auditor, or their duly authorized representatives for at least three (3) years after County's final payment to Contractor and/or the final resolution of any claims under this Contract. Contractor shall incorporate this provision in any subcontract entered into as a result of this Contract.

## **2.3 RESPONSIBILITIES OF OWNER**

**2.3.1 Removal, Relocation, or Protection of Underground Infrastructure:** If the Contractor while performing the contract discovers utility facilities not identified by the Owner in the contract plans or specifications, Contractor shall immediately notify the Owner in writing. Owner shall have the sole discretion to perform the repairs or relocation work itself, or to permit the Contractor to do such repairs or relocation work at a reasonable price. In the event that the Owner authorizes the Contractor to perform the work, the parties shall proceed with a written Change Order as set forth in Article 5 herein. Compensation to the Contractor for said costs shall be in accordance with Section 4215 of the Government Code.

Nothing herein shall be construed to require the Owner to locate the presence of any existing services not expressly included in Government Code Section 4215, nor to limit the Owner's rights or remedies set forth therein.

In accordance with the provisions of Section 4215 of the California Government Code, Contractor shall not be assessed liquidated damages for delay in completion of the project, when such delay was caused by the failure of the Owner or owner of the utility to provide for the removal or relocation of such utility facilities.

## **ARTICLE 3**

### **CONTRACTOR'S RESPONSIBILITIES**

#### **3.1 REVIEW OF CONTRACT DOCUMENTS AND FIELD CONDITIONS**

**3.1.1 Reporting Errors in Contract Documents:** The Contractor shall carefully study and compare the Contract Documents with each other and shall at once report to the Inspector errors, inconsistencies, or omissions discovered. If the Contractor performs any construction activity knowing it involves a recognized error, inconsistency, or omission in the Contract Documents without such notice to the Owner, the Contractor shall assume responsibility for such performance and shall bear all costs for correction.

**3.1.2 Reporting Errors in Field Conditions:** The Contractor shall take field measurements and verify field conditions and shall carefully compare such field measurements and conditions and other information known to the Contractor with the Contract Documents before commencing activities. Errors, inconsistencies, or omissions discovered shall be reported to the Owner at once.

**3.1.3 No Implied Warranty:** No warranty is to be implied nor shall any warranty arise by operation of law, or by interpretation of this Contract, that the Plans and Contract Documents are adequate and sufficient to construct the Project.

## 3.2 SUPERVISION AND CONSTRUCTION PROCEDURES

- 3.2.1 Supervision of Work: The Contractor shall supervise and direct the Work, using the Contractor's best skill and attention. The Contractor shall be solely responsible for and have control over construction means, methods, techniques, sequences, and procedures and for coordinating all portions of the Work under the Contract, unless Contract Documents give other specific instructions concerning these matters.
- 3.2.2 Acts of Employees and Agents: The Contractor shall be responsible to the Owner for acts and omissions of the Contractor's employees, subcontractors and their agents and employees, and other persons performing portions of the Work under a contract with the Contractor.
- 3.2.3 Acts Do Not Waive Contractor's Obligation: The Contractor shall not be relieved of obligations to perform the Work in strict accordance with the Contract Documents either by activities or duties of the Owner's Representative or the Inspector in the administration of the Contract, or by tests, inspections, or approvals required or performed by persons other than the Contractor.

## 3.3 PROSECUTION OF WORK

- 3.3.1 Time of the Essence: It is expressly understood and agreed that the time of beginning, rate of progress, and time of completion of the Work are of the essence. The time for completion of this contract shall be **ninety-six (96) calendar days** commencing from the date shown on the Contractor Notice to Proceed.
- 3.3.2 Owner and Contractor recognize that time is of the essence of the Agreement and that Owner will suffer financial loss if the Work is not completed within the times specified, plus any extensions thereof. They also recognize the delays, expense, and difficulties involved with proving in a legal proceeding the actual loss suffered by Owner if the Work is not completed on time. Accordingly, instead of requiring any such proof, Owner and Contractor agree that Contractor shall pay Owner the sum of **One Thousand, Five Hundred Dollars (\$1,500) per day**, as liquidated damages and not as a penalty, for each and every calendar day's delay in finishing the Work in excess of the contract time prescribed herein.
- 3.3.3 Work During Operational Hours: The Facility will be operational during the Work. The Contractor shall not interfere or hinder government center operations. The Contractor shall keep all equipment and materials within designated work areas and out of hallways and doorways. Emergency exit routes shall be maintained at all times.
- 3.3.4 Construction Schedule: The Contractor shall coordinate the final critical path method (CPM) construction schedule with the Owner. The CPM schedule is required to be submitted within five (5) calendar days of issuance of Notice to Proceed. The CPM schedule will be for Owner's information only. Silence or inaction with regard to Contractor's schedule shall not be construed as acquiescence or acceptance of the schedule as being binding on Owner. Contractor's schedule shall provide for the completion date not to exceed nor shall it provide for the completion date earlier than the time limits for completion set forth in the Contract Documents. Float, whether for the entire Project or for specific tasks therein, shall be deemed to be for the benefit of the Owner. The Contractor shall keep the construction schedule current, and shall submit weekly updates to the Owner's Representative and Inspector, if any. The Contractor shall further prepare and keep current a schedule of submittals which is coordinated with the construction schedule, and which allows the Owner reasonable time to review the submittals.

## 3.4 SUBMITTALS

- 3.4.1 Use of Listed Manufacturers; Review of "Or Equals": Contractor shall utilize only the manufacturer designated in its Proposal for major equipment items listed therein. In accordance with the provisions of Section 3400 of the California Public Contract Code, but subject to Subsection (b) thereof, if requesting approval of an "or equal" product, Contractor shall within two (2) business days following the bid opening

submit data substantiating its request. Failure to submit such substantiating data within two (2) business days following the bid opening shall constitute submission of a non-responsive bid.

### **3.5 STATE AND FEDERAL LABOR REQUIREMENTS**

#### **3.5.1 Hours of Work:**

1. Eight (8) hours of labor shall constitute a legal day's work upon all work done hereunder, and it is expressly stipulated that no workman employed at any time by the Contractor, or by any subcontractor under this Contract, upon the Work, shall be required or permitted to work thereon more than eight (8) hours in any one (1) calendar day and/or more than forty (40) hours in any one (1) calendar week except as provided in Section 1815 of the Labor Code of California, and it is further expressly stipulated that for each and every violation of said last named stipulation, said Contractor shall forfeit, as penalty to the said Owner, \$25.00 for each workman employed in the execution of this Contract, or by any subcontractor under this Contract, for each calendar day during which said workman is required or permitted to labor more than eight (8) hours in any one (1) calendar day or more than forty (40) hours in any one (1) calendar week in violation of the provisions of said Labor Code.
2. In accordance with the provisions of Section 1776 of the Labor Code of the State of California, the Contractor, and each subcontractor, shall also keep an accurate record showing the names and actual hours worked for all workers employed by him in connection with the Work contemplated by the Agreement, which record shall be open at all reasonable hours to the inspection of the Owner or its officers or agents, and to the Chief of the Division of Labor Statistics and Law Enforcement or the Department of Industrial Relations, his deputies or agents.

#### **3.5.2 Apprentice Employment:**

1. Pursuant to the provisions of Section 1777.5 of the Labor Code as amended, the Contractor or subcontractor employing tradesmen in any apprenticeable occupation shall apply to the joint apprenticeship committee nearest the site of the public works project and which administers the apprenticeship program in that trade for a Certificate of Approval. The certificate will also fix the ratio of apprentices to journeymen that will be used in the performance of the Contract. All requirements and exceptions to those requirements set forth herein for Apprenticeship Employment are contained in Labor Code Section 1777.5 and are available from the applicable Joint Apprenticeship Committee.
2. The Contractor shall make contributions to funds established for the administration of the apprenticeship programs if he employs registered apprentices or journeymen in any apprenticeable trade on such contracts and if other contractors on the public works site are making such contributions.
3. The Contractor and any subcontractor under him shall comply with the requirements of Sections 1777.5 and 1777.6 in the employment of apprentices. Information relative to apprenticeship standards, wage schedules, and other requirements may be obtained from the Director of Industrial Relations, ex officio the Administrator of Apprenticeship, San Francisco, California, or from the Division of Apprenticeship Standards and its branch offices.

#### **3.5.3 Wage Rates:**

1. Pursuant to Labor Code Section 1770 et seq., each laborer or mechanic of Contractor or any subcontractor engaged in work on the Project under this Contract shall be paid not less than the hourly wage rate of per diem wages set forth in the prevailing wage rate schedule published by the Director of Industrial Relations regardless of any contractual relationship which may be alleged to exist between Contractor or any subcontractor and such laborers and mechanics.

2. Any laborer or mechanic employed to perform work on the Project under this Contract, which work is not covered by any of the foregoing classifications, shall be paid not less than the prevailing rate of per diem wages specified herein for the classification which most nearly corresponds to the work to be performed by him.
3. The foregoing specified prevailing wage rates are minimum rates only, and the Contractor may pay any wage rate in excess of the applicable rate contained in this Contract.
4. Pursuant to Labor Code Section 1775, the Contractor as a penalty to the Owner shall forfeit \$50.00 for each calendar day, or portion thereof for each worker paid less than prevailing rate established by the Department of Industrial Relations for such work or craft in which such worker is employed. The difference between such prevailing wage rates and the amount paid to each worker for each calendar day or portion thereof for which the worker was paid less than the prevailing wage rate shall be paid to each worker by the Contractor.
5. An error on the part of an awarding body does not relieve the Contractor from responsibility for payment of the prevailing rate of per diem wages and penalties pursuant to Labor Code Sections 1770 - 1775.
6. All Contractors and subcontractors are subject to the provisions of Sections 1810-1814 of the California Labor Code which provide that the maximum hours a worker is to be employed is limited to eight (8) hours a day and forty (40) hours a week and the Contractor or subcontractor shall forfeit, as a penalty, \$25.00 for each worker employed in the execution of the Contract for each calendar day during which a worker is required or permitted to labor more than eight (8) hours in any calendar day or more than forty (40) hours in any calendar week and is not paid overtime.
7. Section 1815 of the California Labor Code requires that notwithstanding the provisions of Sections 1810-1814, employees of Contractors who work in excess of eight (8) hours per day and forty (40) hours per week shall be compensated for all hours worked in excess of eight (8) hours per day at not less than 1-1/2 times the basic rate of pay.
8. In the case of federally funded projects, where federal and state prevailing wage requirements apply, compliance with both is required. This project is funded in whole or part by federal funds. Contractor's attention is directed to the requirements of, and compliance with the Copeland Act (18 U.S.C. 874 and 29 CFR Part 3), the Davis-Bacon Act (40 U.S.C. 276a to 276a-7 and 29 CFR Part 5), and the Contract Work Hours and Safety Standards Act (40 U.S.C. 327-330 and 29 CFR Part 5).
9. If there is a difference between the minimum wage rates predetermined by the Secretary of Labor and the general prevailing wage rates determined by the Director of the California Department of Industrial Relations for similar classifications of labor, Contractor and subcontractors shall pay not less than the higher wage rate. The Department will not accept lower State wage rates not specifically included in the Federal minimum wage determinations. This includes "helper" (or other classifications based on hours of experience) or any other classification not appearing in the Federal wage determinations. Where Federal wage determinations do not contain the State wage rate determination otherwise available for use by Contractor and subcontractors, Contractor and subcontractors shall pay not less than the federal minimum wage rate which most closely approximates the duties of the employees in question.
10. Interested parties can obtain the current wage information by submitting requests to the Department of Industrial Relations, Division of Labor Statistics and Research, PO Box 420603, San Francisco CA 94142-0603, Telephone (415) 703-4708 or by referring to the website at <http://www.dir.ca.gov/dlsr/PWD>. The rates at the time of the bid advertisement date of a project will remain in effect for the life of the project in accordance with the California Code of Regulations, as modified and effective January 27, 1997.



11. Copies of the applicable state prevailing wage rates are on file with the County of El Dorado, Chief Administrative Office, Facilities Division, 3000 Fairlane Court, Placerville, CA 95667, and they are available to any interested party on request.

**3.5.4** Certified Payroll: As required under the provisions of Labor Code Section 1776 Contractor and subcontractors shall keep accurate payroll records:

1. The payroll records shall show the name, address, social security number, work classification, straight time and overtime hours worked each day and week, and the actual per diem wages paid to each journeyman, apprentice, worker, or other employee by him or her in connection with the Project.
2. A certified copy of all payroll records enumerated above shall be available for inspection at all reasonable hours at the principal office of the Contractor as follows:
  - a. Make available or furnish to the employee or his or her authorized representative on request.
  - b. Make available for inspection or furnished upon request to a representative of the Owner, the Division of Labor Standards Enforcement, and the Division of Apprenticeship Standards of the Department of Industrial Relations.
  - c. Make available upon request by the public for inspection or copies thereof made; provided, however, that a request by the public shall be made through either the Owner, the Division of Labor Standards Enforcement, or the Division of Apprenticeship Standards. The requesting party shall, prior to being provided the records, reimburse the costs of preparation by the Contractor, subcontractor, and the entity through which the request was made. The public shall not be given access to the records at the principal office of the Contractor.

**3.5.5** Discrimination In Employment: No discrimination shall occur in the employment of persons upon the Work because of race, color, sex, national origin, or ancestry or religion of such persons.

**3.5.6** Convict-Made Materials: Except as may be provided by law, the Contractor agrees that no materials manufactured or produced in a penal or correctional institution shall be incorporated in the construction under this Contract.

## **3.6 TAXES**

**3.6.1** Contractor Pays Taxes: The Contractor and subcontractors shall pay all local, state, and federal taxes upon labor or materials involved in their branch of the Work, cost of same to be included in the Contract price.

## **3.7 COMPLIANCE WITH LAW AND LOCAL REQUIREMENTS**

**3.7.1** Regulations: The Contractor and all subcontractors shall conform to and abide by all city, county, and state laws, ordinances, rules, and regulations, as the same pertain to the Work contemplated by said Plans and Contract Documents.

**3.7.2** Permits, Licenses, and Fees: The County shall procure and pay for all permits and inspection fees that may be required to commence, carry on, and complete the Contract. Contractor shall be responsible for all applicable license fees.

**3.7.3** Patent Rights, Copyrights, Trade Names, and Royalties: The Contractor shall indemnify and save harmless the Owner and all persons acting under him for all liability on account of any patent rights, copyrights, or trade names which may affect the articles or materials or their application under the Contract Documents. The Contractor shall pay all royalties, or other charges that may arise, due to methods, types of

construction, processes, materials or use of equipment, and shall hold the Owner harmless from any charges whatsoever which may arise, and shall furnish written assurance, satisfactory to the Owner, that such charges have been paid.

### **3.8 GUARANTEE**

3.8.1 **Final Guarantee:** The Contractor shall guarantee all materials and equipment furnished and work performed for a period of one (1) year. Contractor warrants and guarantees for a period of one year from the date of the Notice of Acceptance that the Work is free from all defects due to faulty materials or workmanship and Contractor shall promptly make such corrections as may be necessary, including repairs of any damage to other parts of the Work resulting from such defects. Owner will give notice of observed defects with reasonable promptness. In the event that Contractor should fail to make such repairs, adjustments, or other work that may be made necessary by such defects within ten (10) calendar days after being notified in writing by Owner, Owner may do so and charge Contractor the cost thereby incurred.

3.8.2 **Extended Guarantees:** If a guaranty exceeding one year is provided by the supplier or manufacturer of any equipment used in this Project, then the guarantee for such materials shall be extended for such term. Contractor expressly agrees to act as co-guarantor of such equipment and materials, and Contractor shall supply Owner with all warranty and guaranty documents relative to equipment and materials incorporated in the job and guaranteed by their suppliers or manufacturers.

### **3.9 WARRANTY**

3.9.1 **Contract Warranty:** The Contractor warrants to the Owner that materials and equipment furnished under the Contract will be of good quality and new, unless otherwise required or permitted by the Contract, that the Work will be free from defects or flaws and is of the highest quality of workmanship and that the Work will conform with the requirements of the Contract. Work not conforming to these requirements, including substitutions not properly approved and authorized, shall be considered defective.

### **3.10 INDEMNIFICATION**

3.10.1 **Owner Not Liable for Damages:** The Owner or its authorized representative shall not in any way or manner be answerable or suffer loss, damage, expense, or liability for any loss or damage that may happen to said Work, or part thereof, or in or about the same during its construction and before acceptance and the said Contractor shall assume all liabilities of every kind or nature arising from said Work, either by accident, negligence, theft, vandalism, or any cause whatever; and shall hold the Owner and its authorized representatives harmless from all liability of every kind and nature arising from accident, negligence, or any cause whatever, other than for the active negligence of the Owner, its officers, agents and employees.

3.10.2 **Owner Not Liable for Debts:** Indebtedness incurred for any cause in connection with this Work must be paid by the Contractor, and the Owner is hereby relieved at all times from any indebtedness or claim other than the Contract price.

3.10.3 **Indemnity:** To the fullest extent allowed by law, Contractor shall defend, indemnify, and hold the County and its officers, directors, and employees, harmless against and from any and all claims, suits, losses, damages, and liability for damages, including attorney's fees and other costs of defense brought for or on account of injuries to or death of any person, including but not limited to, workers and the public, or on account of injuries to or death of County employees or damage to property, or any economic, consequential or special damages which are claimed or which shall in any way arise out of or be connected with Contractor's services, operations or performance hereunder, regardless of the existence or degree of fault or negligence on the part of the County, the Contractor, subcontractors or employees of any of these, except

for the active, or sole negligence of the County its officers and employees, or where expressly prescribed by statute.

The duty to indemnify and hold harmless the County specifically includes the duties to defend set forth in Section 2778 of the Civil Code. The insurance obligations of Contractor are separate, independent obligations under the Contract Documents, and the provisions of this defense and indemnity are not intended to modify nor should they be construed as modifying or in any way limiting the insurance obligations set forth in the Contract Documents.

**3.10.4 Environmental Indemnification:** To the fullest extent allowed by law, from and after recording of the Notice of Acceptance, Contractor shall indemnify, defend, and save harmless Owner from all losses or damages resulting from injury to or death of any person and damage to property, and any fine, which is occasioned by or arises out of any breach of Environmental and Toxics Warranty, representations, or covenants of Contractor under this Contract. Contractor further agrees to indemnify and hold harmless Owner, its officers, employees, and agents, from and against any and all liability as follows:

1. Including all foreseeable and all unforeseeable consequential damages, directly or indirectly arising out of the use, generation, storage, or disposal of hazardous materials in any location by Contractor, and
2. Including, without limitation, the cost of any required or necessary repair, cleanup, or detoxification and the preparation of any closure or other required plans, whether such action is required or necessary prior to or following filing of the Notice of Acceptance to the full extent that such action is attributable, directly or indirectly, to the presence or use, generation, storage, release, threatened release, or disposal of hazardous materials by any person on the Project prior to filing of the Notice of Acceptance. Contractor's obligations pursuant to the foregoing indemnity shall survive the filing of the Notice of Acceptance of the Project.
3. This agreement as to indemnity and reimbursement as above set forth to be undertaken by the Contractor shall survive the performance of the remainder of said Contract and shall remain in full force and effect notwithstanding such performance.
4. The foregoing duties of indemnity shall not apply to loss, damage, expense, or liability caused solely by the active negligence of the Owner or the Owner's agents, servants or independent contractors.

### **3.11 WORK REQUIREMENTS**

**3.11.1 Conduct of Work:** The Contractor shall confine the storage of his equipment and materials to limits as designated. He shall at all times exercise due caution and provide all necessary barricades and other safety equipment around the Work to protect the general public from injury to person and property during the entire time of performance of the Work. The Contractor shall not create excessive dust or noise.

**3.11.2 Maintenance of Site:** Strict prohibition against committing nuisances in or about the Work shall be maintained, and the Contractor shall not in any way obstruct or interfere with movements of traffic on any public right of way without first obtaining the necessary approval of the proper public agency.

**3.11.3 Clean Up of Site:** The Contractor shall keep the premises and surrounding area free from accumulation of waste materials or rubbish caused by operations under the Contract. At completion of the Work the Contractor shall remove from and about the Project waste materials, rubbish, the Contractor's tools, construction equipment, machinery, and surplus materials. If the Contractor fails to clean up as provided in the Contract Documents, the Owner may do so and the cost thereof shall be charged to the Contractor.

#### 3.11.4 Cutting and Patching:

1. The Contractor shall be responsible for cutting, fitting, or patching required to complete the Work or to make its parts fit together properly.
2. The Contractor shall not damage or endanger a portion of the Work or fully or partially completed construction of the Owner or separate contractors by cutting, patching, or otherwise altering such construction, or by excavation. The Contractor shall not cut or otherwise alter such construction by the Owner or a separate contractor except with written consent of the Owner and of such separate contractor; such consent shall not be unreasonably withheld. The Contractor shall not unreasonably withhold from the Owner or a separate contractor the Contractor's consent to cutting or otherwise altering the Work.

### **3.12 SUBCONTRACTORS**

3.12.1 Contractor Responsible for Subcontractor's Acts: Contractor shall be fully responsible to Owner for the acts and omissions of his subcontractors, and of persons either directly or indirectly employed by them, as he is for the acts and omissions of persons directly employed by him.

3.12.2 Contractor's Subcontract: Contractor shall cause appropriate provisions to be inserted in all subcontracts relative to the Work to bind subcontractors to Contractor by the terms of the Contract Documents insofar as applicable to the Work of subcontractors and to give Contractor the same power as regards terminating any subcontract that Owner may exercise over Contractor under any provisions of the Contract Documents. The percentage of retention withheld from any subcontractor by the Contractor shall not exceed the percentage of retention withheld from the Contractor as provided herein.

3.12.3 Ineligible Subcontractor: Contractor is prohibited from performing work with a subcontractor who is ineligible to perform work pursuant to Labor Code Section 1777.1 or 1777.7.

### **3.13 SUPERINTENDENT**

3.13.1 Work Superintendent: The Contractor will employ and maintain on the worksite a qualified supervisor or Superintendent who shall have been designated in writing by the Contractor as the Contractor's representative at the sites. The Superintendent shall have full authority to act on behalf of the Contractor, and all communications given to the Superintendent shall be as binding as if given to the Contractor. The Superintendent shall be present on the site at all times as required to perform adequate supervision and coordination of the Work.

### **3.14 LABOR AND MATERIALS**

3.14.1 Skilled Labor: All labor must be especially skilled for each kind of work, and must be thorough and first class in all respects. Any person whom the Inspector or Owner may deem incompetent or disorderly shall be promptly discharged from the Project and not re-employed.

3.14.2 Quality of Materials: All materials used on this Contract shall be new and the best market quality, unless specified or shown otherwise. All Work executed under this Contract shall be done in the best, most thorough, substantial and workmanlike manner and without flaws. All materials and labor shall be subject to the approval of the Inspector as to its quality and fitness, and shall be immediately removed if it does not meet with his approval. The Inspector may refuse to issue the Certificate for Payment until all defective materials or work have been removed and other material of proper quality substituted therefore. All removal and replacement with same shall be done at the Contractor's expense. Manufactured articles,

materials, and equipment shall be applied, installed, connected, erected, used, cleaned, and conditioned as directed by the manufacturer.

## **ARTICLE 4**

### **ADMINISTRATION OF CONTRACT**

#### **4.1 ADMINISTRATION OF CONTRACT**

4.1.1 Contract Communications: Unless otherwise provided in the Contract or when direct communications have specifically been authorized, all parties shall communicate through the Owner's Representative or the Inspector if the Owner so directs. Communications by and with the subcontractors and material suppliers shall be through the Contractor. Communications by Contractor to separate contractors, architect, or Project Manager shall be through the Owner's Representative.

4.1.2 Control of Work: The Owner's Representative or the Inspector will not have control over or charge of and will not be responsible for construction means, methods, techniques, sequences or procedures, or for safety precautions and programs in connection with the Work, since these are solely the Contractor's responsibility. The Owner's Representative or the Inspector will not be responsible for the Contractor's failure to carry out the Work in accordance with the Contract Documents. The Owner's Representative or the Inspector will not have control over or charge of and will not be responsible for acts or omissions of the Contractor, subcontractors, or their agents or employees, or of any other persons performing portions of the Work.

4.1.3 Recommendation for Payments: Based on his or her observations and evaluations of the Contractor's Applications for Payment, the Owner's Representative will review amounts due the Contractor and will recommend to Owner, payments to Contractor as set forth in the section entitled CERTIFICATION FOR PAYMENTS.

4.1.4 Inspector's Authority: The Inspector will have the authority to stop work whenever necessary to ensure a proper execution of the Work. The Inspector will also have authority to reject Work which does not conform to the Contract Documents. Whenever the Inspector considers it necessary or advisable for implementation of the intent of the Contract Documents, the Inspector will have authority to require additional inspection or testing of the Work in accordance with the following section whether or not such Work is fabricated, installed, or completed. However, neither this authority of the Inspector nor a decision made in good faith either to exercise or not to exercise such authority shall give rise to a duty or responsibility of the Inspector to the Contractor, subcontractors, material and equipment suppliers, their agents or employees, or other persons performing portions of the Work. In the event an Inspector is not appointed by the Owner, the Owner's Representative shall have the authority set forth herein.

#### **4.2 INSPECTION AND TESTING**

4.2.1 Advance Notice: Contractor shall provide Owner's Representative seventy-two (72) hours notice prior to beginning work at a specific location and for a specific department. Contractor shall notify Owner's Representative and Inspector forty-eight (48) hours prior to any day in which Contractor will 1) require an inspection of any portion of the Work, 2) work in excess of eight (8) hours or any time Contractor intends to work weekends, and 3) require shut down of all or any portion of building systems (electrical, plumbing, fire, mechanical, etc.). Any work not performed subject to inspection will not be accepted and will be rejected and/ or ordered removed by Owner, or Inspector.

4.2.2 Access to Work: The Owner's Representative, the Architect, the Project Manager, and the Inspector will at all times have access to the Work. In addition, authorized representatives and agents of any participating Federal or State Agency shall be permitted to inspect all Work, materials, payrolls, and records on

personnel, invoices of materials, and other relevant data and records. The Contractor will provide proper facilities for such access and observation of the Work and also for any inspection or testing thereof.

4.2.3 Costs of Tests: The Owner shall bear all costs related to testing for conformance of the Work to the Contract requirements. However, if the Contractor has called for any testing, and that test fails, subsequent tests, and all related costs, shall be borne by the Contractor.

4.2.4 Preparation of Change Directives/Orders: The Owner's Representative or the Inspector, if one is appointed, will prepare Change Orders and Construction Change Directives, and may authorize minor changes in the Work as provided in the section entitled CHANGES IN WORK.

### 4.3 CLAIMS

4.3.1 Concealed or Unforeseen Conditions: It is understood by both parties that Contractor has made a pre-contract investigation of the site. All concealed, unforeseen, or materially differing conditions are the responsibility of the Contractor in the absence of an actual material, intentional misrepresentation by the Owner as to the conditions on the site. Contractor shall give written notice of any conditions encountered at the site which are unforeseen, concealed, or materially different from those set forth in the Plans or Contract Documents, or ordinarily encountered and generally recognized as inherent in the Work. Such written notice shall be given within five (5) calendar days of his discovery of any such facts.

4.3.2 Notice of Discovery of Hazardous Waste or Unusual Conditions:

1. The Contractor shall promptly, and before the following conditions are disturbed, notify the Owner in writing, in the event the Contractor encounters any of the following:
  - a. Material that the Contractor believes may be hazardous waste, as defined in Section 25117 of the Health and Safety Code that is required to be removed to a Class I, Class II, or Class III disposal site in accordance with provisions of existing law.
  - b. Unknown physical conditions at the site of any unusual nature, different materially from those ordinarily encountered and generally recognized as inherent in the work of the character provided for in the contract.
2. The Owner shall promptly investigate the conditions, and if it finds that the conditions do materially so differ, or do involve hazardous waste, or cause a decrease or increase in the Contractor's cost of, or time required for, performance of any part of the work shall issue a change order under the procedures described herein.
3. In the event a dispute arises between the Owner and the Contractor whether the conditions materially differ, or involve hazardous waste, or cause a decrease or increase in the Contractor's cost of, or time required for, performance of any part of the work, the Contractor shall not be excused from any scheduled completion date provided for in the contract, but shall proceed with all work to be performed under the Contract. The Contractor shall retain any and all rights provided either by contract or by law which pertain to the resolution of disputes and protests between the Contractor and the Owner.

4.3.3 Time Limits on Claims: Claims by Contractor must be made within ten (10) calendar-days after occurrence of the event giving rise to such Claim, except that claims made due to delay or hindrances which Contractor claims was caused by Owner shall be made within five (5) calendar-days after occurrence of the event giving rise to such Claim. Claims must be made by written notice. Failure to make such claim in writing in the time set forth herein shall bar Contractor from recourse for such claim. All claims must be filed on or before the payment date of Final Payment.

4.3.4 Claims for Additional Costs:

1. If Contractor wishes to make a Claim for an increase in the Contract Price, he shall give the Owner written notice thereof within the time set forth in Paragraph 4.3.3. This notice shall be given by the Contractor before proceeding to execute the work, except in an emergency endangering life or property in which case the Contractor shall, as soon as possible, advise Owner of his intent to do the Work.
2. Increases in Contract Price due to Claims shall be calculated based on the Cost Reimbursement method detailed in Paragraph 5.4.1.3.
3. Under no circumstances shall Contractor recover any administrative overhead costs or recover on the basis of any "Home Office" damages formula, "Total Cost" recovery formula, or any other such formula.

4.3.5 Claims for Additional Time:

1. If the Contractor wishes to make Claim for an increase in the Contract Time, written notice as provided herein shall be given. The Contractor's Claim shall include an estimate probable effect of delay on progress of the Work.
2. If adverse weather conditions are the basis for a Claim for additional time, such Claim shall be documented by data substantiating that weather conditions were abnormal for the period of time and could not have been reasonably anticipated, and that weather conditions had an adverse effect on the scheduled construction.
3. The Owner shall not be liable for any damages on account of any reasonable delay or hindrance of the Owner. However, Contractor shall be entitled to an extension of time for any delay or hindrance caused by the Owner. Any delay or hindrance by Owner which is unreasonable and not within the contemplation of the parties may subject Owner to a claim for damages. Contractor shall make any claims in writing within the time set forth in Paragraph 4.3.3., for any unreasonable delay or hindrance caused by Owner, and specifying the cause thereof as required in paragraph "Submittal of Claims".

4.3.6 Submittal of Claims: Any disputes relating to this Contract, or its breach, which is not disposed of by agreement shall be promptly submitted as a claim to the Owner's Representative who shall issue a written response on the dispute. Claims shall be submitted by the Contractor to the Owner's Representative with adequate supporting data and include a demand for the Owner's Representative's decision. Adequate supporting data shall include, but is not limited to, a statement of the reasons for the asserted entitlement, the certified payroll, invoice for material and equipment rental, and an itemized breakdown of any adjustment sought.

4.3.7 Submission Under Penalty of Perjury: The Contractor shall certify, at the time of submission of a claim, as follows:

"I certify under penalty of perjury under the laws of the State of California, that the claim is made in good faith, that the supporting data are accurate and complete, and that the amount requested accurately reflects the contract adjustment for which the Owner is liable.

By: \_\_\_\_\_  
“(Contractor's signature)”

4.3.8 Third Party Claims: Owner will notify Contractor of receipt of any third party claim relating to the contract within five (5) calendar days of receipt of such claim.

## 4.4 DISPUTES RESOLUTION

4.4.1 Continue Work During Dispute: In the event of any dispute between the Owner and the Contractor, the Contractor will not stop Work but will prosecute the work diligently to completion in the manner directed by the Owner, and the dispute shall be resolved as set forth herein after completion of the Work. However, all disputes must be submitted by Contractor in accordance with the subsequent provisions of this section.

4.4.2 Requirements for Filing a Claim: For any claim subject to this Article, the following requirements apply: the claim shall be in writing and include the documents necessary to substantiate the claim. Claims must be filed on or before the date of final payment. Nothing in this subdivision is intended to extend the time limit or supersede notice requirements otherwise provided by this contract for the filing of claims.

1. For claims of less than fifty thousand dollars (\$50,000.00), the Owner shall respond in writing to any written claim within forty five (45) days of receipt of the claim, or may request, in writing, within thirty (30) days of receipt of the claims or relating to defenses or claims the Owner may have against the Contractor, any additional documentation supporting the claim or relating to defenses to the claim the Owner may have against the Contractor.

If additional information is thereafter required, it shall be requested and provided pursuant to this subdivision, upon mutual agreement of the Owner and the Contractor.

The Owner's written response to the claim, as further documented, shall be submitted to the Contractor within fifteen (15) days after receipt of the further documentation or within a period of time not greater than that taken by the Contractor in producing the additional information, whichever is greater.

2. For claims of over fifty thousand dollars (\$50,000.00) and less than or equal to three hundred seventy-five thousand dollars (\$375,000.00), the Owner shall respond in writing to all written claims within sixty (60) days of receipt of the claim, or may request, in writing, within thirty (30) days of receipt of the claim, any additional documentation supporting the claim or relating to the defenses or claims the Owner may have against the Contractor.

If additional information is thereafter required, it shall be requested and provided pursuant to this subdivision, upon mutual agreement of the Owner and the Contractor.

The Owner's written response to the claim, as further documented, shall be submitted to the Contractor within thirty (30) days of receipt of the further documentation, or a period of time no greater than that taken by the Contractor in producing the additional information or requested documentation, whichever is greater.

3. If the Contractor disputes the Owner's written response, or the Owner fails to respond within the time prescribed, the Contractor may so notify the Owner, in writing, either within fifteen (15) days of receipt of the Owner's written response or within fifteen (15) days of Owner's failure to respond within the time prescribed, respectively, and demand an informal conference to meet and confer for settlement of the issues in dispute. Upon a demand, the Owner shall schedule a meet and confer conference within thirty (30) days for settlement of the dispute.
4. If following the meet and confer conference the claim or any portion remains in dispute, the Contractor may file a claim pursuant to Chapter 1 (commencing with Section 900) and Chapter 2 (commencing with Section 910) of Part 3 of Division 3.6 of Title 1 of the Government Code, and in accordance with Section 20104.2 of the Public Contract Code.

4.4.3 Owner's Review of Claim: The Owner's Representative shall review the facts pertinent to the claim, secure assistance from legal and other advisors, coordinate with the contract administrators, and promptly provide a written response. The response shall be furnished to the Contractor by certified mail, return receipt



requested, or any other method that provides evidence of receipt. The Owner's Representatives' response shall be final and conclusive except as is otherwise provided herein.

**4.4.4** Claims Exempt from Review: The procedures and remedies provided in this Section 4.4 do not apply to:

1. Any claims by the Owner.
2. Any claim for or respecting personal injury or death or reimbursement or other compensation arising out of or resulting from liability for personal injury or death.
3. Any claim or dispute relating to stop payment requests or stop notices.
4. Any claim related to the approval, refusal to approve, or substitution of subcontractors, regardless of tier, and suppliers.

**4.4.5** Suit in El Dorado County Only: Any litigation arising out of this Contract shall be brought in El Dorado County. The Owner and the Contractor shall follow procedures established for all civil actions filed to resolve claims pursuant to Public Contract Code Section 20104 et seq., including but not limited to Section 20104.4.

**4.4.6** Payment of Undisputed Portion of Claim: Payment by Owner of undisputed portion of claim; interest on arbitration award or judgment.

1. Owner shall pay Contractor such portion of a claim which is undisputed except as otherwise provided in the contract.
2. In any suit filed pursuant to Public Contract Code Section 20104.4, the provisions of Section 20104.6 shall apply.
3. The rate of interest payable on unpaid and undisputed claims shall be 6 percent per annum. Interest shall begin to accrue sixty-one (61) days after the Contractor submits to the Owner information in sufficient detail to enable the Owner to accept the claim statement.
4. The rate of interest payable on any judgment or award in arbitration shall not exceed 6% per annum in accordance with Civil Code Section 3287 et seq.

## **ARTICLE 5**

### **CHANGES IN WORK**

#### **5.1 WAIVER**

**5.1.1** Waivers of Contract Provisions: It is expressly understood and agreed that no waiver granted by the Inspector or the Owner of any term, provision, or covenant of this Contract shall constitute a precedent for breach of the same or any other terms, provisions, or covenants of this Contract.

#### **5.2 CHANGES**

**5.2.1** Owner May Order Changes in Work: The Contractor agrees that the Owner, without invalidating the Contract, may order changes in Work by altering, adding to, or deducting from the Work, the Contract Amount and Time being adjusted according to the provisions of Section 5.4 and Section 5.5. Contractor agrees to enter into a modification of his original Contract for such changes.

5.2.2 **Cost Proposals:** Upon request of the Owner for a quotation on the change to the Work, the Contractor shall promptly submit to Owner's Representative, and the Inspector, if one is appointed, in writing a detailed breakdown of the work and of the amount of deduction or addition claimed. In no case shall Cost Proposals be provided later than ten (10) calendar days from the date requested. The Owner's request for quotations on alterations to the Work shall not be considered authorization to proceed with the work prior to issuance of a Change Order, nor shall such request justify any delay in existing work. If Contractor fails to provide Cost Proposals within ten (10) calendar days, Owner may prepare the Cost Proposal based on estimates of labor, materials, and equipment. This proposal, prepared by Owner, shall be binding on the Contractor, will become the basis for Contract Price adjustment, and shall not be subject to dispute or claim.

5.2.3 **Contract Change Instrument:** Changes in work involving a change in Contract Price or Contract Time shall be done only pursuant to an Architect's Supplemental Instructions (if applicable), Change Order, or Construction Change Directive as set forth below in this article.

5.2.4 **Changes Shall Conform to Contract:** Changes in work shall be performed in conformance with applicable provisions of the Contract Documents, and the Contractor shall proceed promptly unless otherwise provided in the Architect's Supplemental Instructions (if applicable), Change Order, or Change Directive.

### **5.3 CONTRACT CHANGE INSTRUMENTS**

5.3.1 **Architect's Supplemental Instructions (ASI) (if applicable):** The Owner's Representative or the Architect, may order minor changes in work by use of an Architect's Supplemental Instruction. These minor changes will involve neither changes in the Contract Price or Contract Time. If the Contractor disagrees that the change does not involve a change in cost or time, then a Change Order or Change Directive shall be used.

5.3.2 **Change Order (CO):** The Change Order shall be used in cases where Owner and Contractor agree on the change in work, the amount of or method of computing the Contract Amount, and the amount of adjustment in Contract Time.

5.3.3 **Construction Change Directive (CCD):** In the event that the Owner and Contractor do not agree on the proposed change in work, and/or the proposed adjustment of Contract Price and Time, or in the event it is essential that the Contractor proceed expeditiously and without delay, then Owner may, by issuance of a Construction Change Directive, order changes in work, and the Contractor shall promptly proceed with the change in work involved.

1. **Acceptance of Change Directive:** If Contractor agrees with the Change Directive, the Contractor shall by his signature thereon, indicate his acceptance of the terms of the Directive, including adjustments to price and time, and the Change Directive shall then be followed by a Change Order.
2. **Non-Acceptance of Change Directive:** If the Contractor disagrees with the method of computing an increase in Contract Price, then the amount of adjustment shall be computed by the Cost Reimbursement method detailed in Basis for Adjustment. Disagreements with amounts or credits, under the Cost Reimbursement method, or time, shall be considered a dispute, and processed under the section on Disputes Resolution.

### **5.4 BASIS OF ADJUSTMENT**

5.4.1 **Methods of Adjustment:** The amount of adjustments to Contract Price, whether a credit or payment, shall be computed by one of the methods detailed below. The method used shall be at the sole determination of the Owner.

1. Unit Prices: Those prices stipulated in the Bid Proposal shall be utilized where they are applicable. In the event the change in original quantity is in excess of twenty five (25) percent of the original bid quantity, and the total dollar value of that bid is greater than \$5,000, the Owner shall review the unit price to determine if a new unit price shall be renegotiated. Unit prices for new items shall be negotiated and mutually agreed upon.
2. Lump Sum: A total lump sum for the Work negotiated and mutually acceptable to the Contractor and Owner. Lump sum quotations for modifications to the Work shall include substantiating documentation with an itemized breakdown of Contractor's and subcontractor's costs, including labor, materials, rentals, approved services, overhead, and profit all calculated as specified in the Cost Reimbursement method which follows.
3. Cost Reimbursement (Extra Work): In this method, the payment for Extra Work shall be made on a time and expense basis that is on an accounting of the Contractor's forces, materials, equipment, and other items of cost as required and used to do the Work. Payment will be made for the documented actual cost of the following:
  - a. Costs of direct labor, excluding supervisory personnel, including social security, old age and unemployment insurance, fringe benefits required by agreement, labor insurance and labor taxes established by law.
  - b. Costs of materials, supplies, and equipment, including cost of transportation and sales tax, whether incorporated if paid for by the Contractor or his subcontractor.
  - c. Rental costs, prevailing in the area, of machinery and equipment for the actual time used, and including transportation costs for items having value in excess of \$100.00.
  - d. Costs of premiums for all bonds and insurance, permit fees, and sales, use or similar taxes related to the Work.

To the above cost the Contractor shall be allowed a markup of fifteen (15) percent on direct labor charges and fifteen (15) percent for all other cost items. When any or all of the Extra Work is done by one of the Contractor's subcontractors, the markups set forth above shall be applied to the subcontractor's actual costs to which a five (5) percent markup shall be allowed the Contractor. These markups shall be considered to be full compensation, covering the cost of general supervision, administration, overhead, profit, and any and all other general expenses, including, but not limited to, uniforms, hand tools, safety equipment, travel and lodging.

## **5.5 EXTENSION OF TIME FOR COMPLETION**

**5.5.1 Contractor Delayed or Hindered:** Should the Contractor be delayed or hindered in the completion of the Work by the neglect of the Owner, or by fire, by strikes, lockouts, embargoes or earthquakes, and any other causes the Inspector approves as not having been reasonably foreseeable at the time of execution of the Contract Documents, then the time allowance herein fixed for the completion of the Work shall be extended for a period equivalent to the time lost by reason of any or all of the causes aforesaid. Time extensions must be requested in accordance with Section 4.3.

**5.5.2 Agreement on Time Extension:** In addition, the Contractor and the Owner reserve the right to mutually agree in writing upon an extension of time for completion for causes other than enumerated above.

**5.5.3 Time Extension Not Waiver:** The granting of an extension of time by the Owner for performance by the Contractor shall not operate as a waiver or stop the Owner from claiming damages due to any other delays, prior or subsequent, which were not approved by the Owner as provided herein.

## ARTICLE 6

### PAYMENTS AND COMPLETION

#### 6.1 GENERAL

- 6.1.1 Contract Price: The Contract Price stated in the Contract is the total amount payable by the Owner to the Contractor for performance of the Work under the Contract Documents.
- 6.1.2 Waiver: Neither the acceptance of the Work by the Owner nor the payment of any part or all of the sum due the Contractor hereunder shall constitute a waiver by the Owner of any claim which the Owner may have against the Contractor or Surety under this Contract or otherwise.
- 6.1.3 Manner of Paying Warrants: Payment becomes due under the terms of this Contract in the manner prescribed by law. The Auditor shall cause a warrant for the Certified amount to be drawn upon the proper fund of the Treasurer of the Owner, which warrant shall be approved and issued to Contractor within that period of time customarily required to process said warrants in the ordinary course of Owner's business.

#### 6.2 APPLICATIONS FOR PAYMENT

- 6.2.1 Submittal of Applications: The Contractor shall submit to the Owner OR Owner's Representative, an Application for Payment form, which will be provided by the Owner. Such application shall be supported by such data substantiating the Contractor's right to payment as the Owner may require, such as copies of requisitions from subcontractors and material suppliers.
- 6.2.2 Basis for Payment: The Payment shall be based upon the total Contract price and upon percentage of completion of the Work at the time of the submittal of the application for payment.
- 6.2.3 Before submitting an Application for Payment (Final or Partial) the Contractor shall reach an agreement with the Project Manager concerning the percentage complete of the Work and the dollar value for which the Application for Payment may be submitted.
- 6.2.4 Work Free of Liens: The Contractor warrants that upon submittal of an Application for Payment, all work for which Certificates for Payment have been previously issued and payments received from the Owner shall be free and clear of liens, claims, security interests, or encumbrances against Contractor by subcontractors, material suppliers, or other persons or entities making a claim by reason of having provided labor, materials, and equipment in relation to the Work.

#### 6.3 CERTIFICATION FOR PAYMENT

- 6.3.1 Certification Determination: The Owner's Representative will review as soon as practicable for the purpose of determining whether it is a proper payment request and shall within seven (7) days after receipt of the Contractor's Application for Payment, either issue to the Owner a Certification for Payment, with a copy to the Contractor, for such amount as determined to be properly due, or notify the Contractor of the reasons why the payment request is not proper and for withholding certification of payment in whole or in part as provided in Section 6.4.1.
- 6.3.2 The Owner shall pay or cause to be paid to Contractor, an amount equal to ninety five percent (95%) as noted in Section 6.4.3 of the amount set forth in the approved Certificate for Payment within thirty (30) days of receipt of an Application for Payment approved by the Owner's representative as provided for in Paragraph 6.3.1 above, and shall retain the remaining five percent (5%) as noted in 6.4.3 until the time provided for in Section 6.6.4. The Owner shall withhold amounts pursuant to stop notices received in

addition to the retainage. Failure of Owner to make payments provided herein in a timely manner shall not constitute a default by the Owner of the Contract, but may entitle the Contractor to interest as provided by law.

## **6.4 WITHHOLDING FROM PAYMENTS**

6.4.1 Reasons for Withholding: The Owner, upon recommendation of the Inspector, may withhold payments, or on account of subsequently discovered evidence nullify the whole or a part of any progress or retention payments to such extent as may be necessary to protect the Owner from loss on account of:

1. Defective work or material not remedied or replaced.
2. The filing of claims or Stop Notices to withhold, or reasonable evidence indicating probable filing of such claims or notices.
3. Failure of the Contractor to make payments properly to subcontractors, or for materials or labor.
4. Failure to make payments to any person or entity for financial obligations of the Contractor under terms of this Contract.
5. A reasonable doubt that the Contract can be completed for the balance then unpaid.
6. Damage to another contractor.
7. Performance of work in violation of the terms of the Contract Documents.
8. Excessive costs to Owner.
9. Failure of Contractor to comply with requirements for timely submittal of specified documentation, including but not limited to construction schedules, cost proposals, and submittals.

6.4.2 Release of Payment: When the above grounds for withholding are removed, payment shall be made for amounts withheld because of them.

6.4.3 Method of Retainage: The Department will retain 5% of the value of each progress payment from each progress payment. The retained funds shall be retained until thirty-five (35) days after recordation of the Notice of Acceptance.

## **6.5 SUBSTITUTE SECURITIES FOR RETENTION**

6.5.1 Substitution of Securities: Bidders are hereby put on notice that the successful bidder may substitute securities for any monies withheld by the County of El Dorado to insure performance of the Contract pursuant to Public Contract Section 22300. This section provides that the Contractor may elect to receive 100 percent of payments due under the Contract Documents from time to time, without retention from any portion of the payment by the County of El Dorado, by depositing eligible securities of equivalent value with the County of El Dorado or qualified escrow agent in accordance with the provisions of Public Contract Code Section 22300. Eligible securities shall be limited to those listed in Section 16430 of the Government Code, or bank or savings and loan certificates of deposit from a qualified institution. Any such escrow agreement shall follow the form set forth in Public Contract Code Section 22300(f) and provided by the Owner.

## **6.6 FINAL COMPLETION AND PAYMENT OF RETAINAGE**

- 6.6.1** Affidavit of Payment: After the date of Substantial Completion of the Work, and before final acceptance of the Work, the Contractor shall file with the Owner his affidavit, sworn to before a Notary Public, stating that all workmen and persons employed, all firms supplying materials, and all subcontractors upon the project for either labor or material have been paid in full, except certain items, if any, to be set forth in such affidavit covering disputed claims, including claims for acceleration, disruption, delays, inefficiencies, and hindrance, or items in connection with which Stop Notices have been filed under the provisions of the Statutes of the State of California. The filing of such affidavit by the Contractor shall be one of the prerequisites to the making, by the Owner, of the final retainage payment on the Contract.
- 6.6.2** Final Inspection: Upon receipt of written notice that the Work is ready for final inspection and acceptance and upon receipt of the Application for Payment, the Owner will promptly make such inspection. The Contractor shall complete all punch list items within two (2) days of receipt of the written punch list. When the Owner's Representative finds the work acceptable under the Contract Documents and the Contract fully performed, the Owner's Representative will promptly recommend to Owner that Owner may consider the Project complete, accept the project, and that the Notice of Acceptance may be issued.
- 6.6.3** Final Certification: Before issuance of payment, Contractor shall file, with Owner, a certificate in which he certifies that to the best of the Contractor's knowledge, information, and belief, and on the basis of observations and inspections, the Work has been completed in accordance with terms and conditions of the Contract Documents.
- 6.6.4** Payment of Retention: Thirty-five (35) days after the Notice of Acceptance has been filed, provided the Work is fully completed and the Contract fully performed, the balance due under the Contract shall be paid, less any monies held for stop notices. Payment shall not be construed as an absolute acceptance of the work done up to the time of such payment. The Contractor, if requested by the Owner, shall furnish receipts or other vouchers showing his payments for materials and labor. Owner may withhold from payment an amount not to exceed 150 percent of any amount in dispute.
- 6.6.5** Notice of Acceptance: The Work shall be accepted in writing in the form of a Notice of Acceptance when the whole of the work has been completed satisfactorily to the Owner. In judging the Work, no allowance for deviations from the original Contract Documents will be made unless already approved in writing at the proper times and in the manner as called for herein.

## **ARTICLE 7**

### **PROTECTION OF PERSONS AND PROPERTY**

#### **7.1 PROTECTION OF WORK, PROPERTY, AND PERSONS**

- 7.1.1** Responsible for Damage to Owner's Property: The Contractor shall be entirely responsible for any damage to the property of the Owner due to careless handling of tools and/or materials or other causes attributed to the Contractor's Work in performing this Contract.
- 7.1.2** Responsible for Safety: The Contractor will take all necessary precautions for the safety of, and will provide the necessary protection to prevent damage, injury, or loss to all employees on the Work and other persons who may be affected thereby, all the Work and all materials or equipment to be incorporated therein, whether in storage on or off the site, and other property at the site or adjacent thereto, including trees, shrubs, lawns, walks, pavements, roadways, structures, and utilities not designated for removal, relocation, or replacement in the course of construction.
- 7.1.3** Safety and Convenience: The Contractor will comply with all applicable laws, ordinances, rules, regulations, and orders of any public body having jurisdiction. The Contractor will erect and maintain, as

required by the conditions and progress of the Work, all necessary safeguards for safety and protection. The Contractor will notify owners of adjacent utilities when prosecution of the Work may affect them.

- 7.1.4 Remedy Damages:** The Contractor will remedy all damage, injury, or loss to any property caused, directly or indirectly, in whole or part, by the Contractor, any subcontractor, or anyone directly or indirectly employed by any of them or anyone of whose acts any of them would be liable, except damage or loss attributable to the sole or active negligence of the Owner or the Inspector or anyone employed by them and not attributable, directly or indirectly, in whole or in part, to the fault or negligence of the Contractor.

## **ARTICLE 8**

### **INSURANCE AND BONDS**

#### **8.1 INSURANCE**

##### **GENERAL INSURANCE REQUIREMENTS**

The Contractor shall provide proof of a policy of insurance satisfactory to the El Dorado County Risk Management Division and documentation evidencing that the Contractor maintains insurance that meets the following requirements:

1. Full Workers' Compensation and Employers' Liability Insurance covering all employees of the Contractor as required by law in the State of California.
2. Commercial General Liability Insurance of not less than Two Million Dollars (\$2,000,000) combined single limit per occurrence for bodily injury and property damage, including but not limited to endorsements for the following coverage: Premises, personal injury, operations, products and completed operations, blanket contractual, and independent contractors liability. This insurance can consist of a minimum \$1 Million primary layer of CGL and the balance as an excess/umbrella layer, but only if the County is provided with written confirmation that the excess/umbrella layer "follows the form" of the CGL policy.
3. Automobile Liability Insurance of not less than One Million Dollars (\$1,000,000) is required in the event motor vehicles are used by the Contractor in performance of the contract.
4. In the event Contractor is a licensed professional and is performing professional services under this contract, Professional Liability Insurance is required with a limit of liability of not less than One Million Dollars (\$1,000,000).
5. Explosion, Collapse and Underground coverage is required when the scope of work includes XCU exposures. For the purpose of this contract, XCU coverage is not required.

##### **PROOF OF INSURANCE REQUIREMENTS**

1. Contractor shall furnish proof of coverage satisfactory to the El Dorado County Risk Management Division as evidence that the insurance required herein is being maintained. The insurance will be issued by an insurance company acceptable to the Risk Management Division, or be provided through partial or total self-insurance likewise acceptable to the Risk Management Division.
2. The County of El Dorado, its officers, officials, employees, and volunteers shall be included as additional insureds, but only insofar as the operations under this Contract are concerned. This provision shall apply to all general liability and excess liability policies. Proof that the County is named additional insured shall be made by providing the Risk Management Division with a certified copy, or other acceptable evidence, of an endorsement to Contractor's insurance policy naming the County additional insured.

3. In the event Contractor cannot provide an occurrence policy, Contractor shall provide insurance covering claims made as a result of performance of this contract for not less than three (3) years following completion of performance of this Contract.
4. Any deductibles or self-insured retentions must be declared to and approved by the County. At the option of the County, either: the insurer shall reduce or eliminate such deductibles or self-insured retentions as respects the County, its officers, officials, employees and volunteers; or the Contractor shall procure a bond guaranteeing payment of losses and related investigations, claim administration and defense expenses.
5. Contractor shall require each of its subcontractors to procure and maintain commercial general liability insurance, automobile liability insurance, and workers compensation insurance of the types and in the amounts specified above, or shall insure the activities of its subcontractors in its own policy in like amounts. Contractor shall also require each of its subcontractors to name Contractor and County of El Dorado as additional insureds.

#### **INSURANCE NOTIFICATION REQUIREMENTS**

1. Contractor agrees no cancellation or material change in any policy shall become effective except upon thirty (30) days prior written notice to the County of El Dorado, Chief Administrative Office, Russell Fackrell, Facilities Division Manager, at 3000 Fairlane Court, Placerville, CA 95667.
2. Contractor agrees that the insurance required herein shall be in effect at all times during the term of this agreement. In the event said insurance coverage expires at any time or times during the term of this Contract, Contractor shall immediately provide a new certificate of insurance as evidence of the required insurance coverage. In the event Contractor fails to keep in effect at all times insurance coverage as herein provided, County may, in addition to any other remedies it may have, terminate this Contract upon the occurrence of such event. New certificates of insurance are subject to the approval of the Risk Management Division.

#### **ADDITIONAL STANDARDS**

Certificates shall meet such additional standards as may be determined by the Department either independently or in consultation with the Risk Management Division, as essential for protection of the County.

#### **COMMENCEMENT OF PERFORMANCE**

Contractor shall not commence performance of this Contract unless and until compliance with each and every requirement of the insurance provisions is achieved.

#### **MATERIAL BREACH**

Failure of Contractor to maintain the insurance required herein, or to comply with any of the requirements of the insurance provisions, shall constitute a material breach of the entire Contract.

#### **REPORTING PROVISIONS**

Any failure to comply with the reporting provisions of the policies shall not affect coverage provided to the County, its officers, officials, employees or volunteers.

#### **PRIMARY COVERAGE**

The Contractor's insurance coverage shall be primary insurance as respects the County, its officers, officials, employees and volunteers. Any insurance or self-insurance maintained by the County, its officers, officials, employees or volunteers shall be in excess of the Contractor's insurance and shall not contribute with it.

#### **PREMIUM PAYMENTS**

The insurance companies shall have no recourse against the County of El Dorado its officers, agents, employees, or any of them for payment of any premiums or assessments under any policy issued by any insurance company.



## CONTRACTOR'S OBLIGATIONS

Contractor's indemnity and other obligations shall not be limited by the insurance required herein and shall survive the expiration of this Contract.

### 8.2 BONDS

- 8.2.1 **General Requirements for Bonds:** Before commencing any Work under the Contract, the Contractor shall provide all bonds to the Owner. These bonds shall be in the amounts and for the purposes specified below. They shall be Surety bonds and shall be issued by corporations duly and legally licensed and qualified to transact business in the State of California. They shall be maintained by him and at his expense during the entire life of the Contract or later as provided.
- 8.2.2 **Performance Bond:** One bond shall be in the amount of 100 percent of the Awarded Contract and shall guarantee the faithful performance of the Contract and shall insure the Owner during the life of the Contract and the Guarantee period. The Contractor may provide, subject to approval by the Owner, a separate guarantee bond upon completion of and acceptance of the work.
- 8.2.3 **Payment Bond:** One bond shall be in the amount of 100 percent of the Awarded Contract and shall guarantee the payment in full of all claims for labor and materials in accordance with the provisions of the laws of the State of California.
- 8.2.4 **Change of Surety:** If, at any time a Surety on such bonds becomes irresponsible or loses its right to do business in the State of California, the Owner may require another Surety which the Contractor shall furnish within ten (10) calendar days after receipt of written notice to do so.
- 8.2.5 **Authentication of Bonds:** Evidence of authority of an attorney-in-fact acting for the corporate Surety must be provided in the form of a certificate as to his power of attorney and to the effect that it is not terminated and remains in full force and effect on the date of the bonds. The form of the bonds shall be in accordance with those provided in the Draft Agreement.

## ARTICLE 9

### UNCOVERING AND CORRECTION OF WORK

#### 9.1 DEVIATION FROM CONTRACT DOCUMENTS

- 9.1.1 **Improper Work:** If the Contractor shall vary from the Contract Documents in the form or quality of the Work, or the amount or value of the materials herein provided for, the Owner shall have the right to order such improper work or materials removed, remade, or replaced. In the event that the Work is ordered changed, any other work disturbed or damaged by such alteration shall be made good at the Contractor's expense.

#### 9.2 CORRECTION OF WORK

- 9.2.1 **Covered or Completed Work:** If any work is covered contrary to the written instructions of the Owner's Representative, or the Inspector, if one is appointed, it must, if requested, be uncovered for observation and replaced at the Contractor's expense.
- 9.2.2 **Inspection of Covered Work:** If the Owner's Representative or the Inspector, if one is appointed, considers it necessary or advisable that covered Work be inspected or tested by others, the Contractor, upon request, will uncover, expose, or otherwise make available for observation, inspection, or testing as the Inspector may require, that portion of the Work in question, furnishing all necessary labor, materials, tools, and

equipment. If it is found that such Work is defective, the Contractor will bear all the expenses of such uncovering, exposure, observation, inspection, and testing and of satisfactory reconstruction; if, however, such Work is not found to be defective, the Contractor will be allowed an increase in the Contract price or an extension of the Contract time, or both, directly attributable to such uncovering, exposure, observation, inspection, testing, and construction, and an appropriate Change Order shall be issued.

9.2.3 Rejected Work: The Contractor shall promptly remove from the premises all Work rejected by Owner for failure to comply with the Contract Documents, whether incorporated in the construction or not, and the Contractor shall promptly replace and re-execute the work either during the term of the Contract or during the warranty period, in accordance with the Contract Documents and without expense to the Owner and shall bear the expense of making good all Work of other contractors destroyed or damaged by such removal or replacement.

9.2.4 Cost of Correction: All removal and replacement Work shall be done at the Contractor's expense. If the Contractor does not take action to remove such rejected Work within ten (10) days after receipt of written notice, the Owner may remove such Work and store the materials at the expense of the Contractor. Owner also may perform such Work or repairs itself and charge the expense to the Contractor.

## **ARTICLE 10**

### **SUSPENSION OF CONTRACT**

#### **10.1 SUSPENSION OF WORK**

10.1.1 Owner May Suspend: The Owner may suspend the Work or any portion thereof for a period of not more than ninety (90) days or such further time as agreed upon by the Contractor, by written notice to the Contractor and the Inspector which shall fix the date on which work shall be resumed.

10.1.2 Resumption of Work: The Contractor shall resume that Work on the dates so fixed. The Contractor shall be allowed an increase in the Contract price or an extension of the Contract time, or both, directly attributed to any suspension.

**\* END OF CONDITIONS OF THE CONTRACT \***

EXHIBIT B

COUNTY OF EL DORADO

HHSA TENANT IMPROVEMENT

3368 SANDY WAY SOUTH LAKE TAHOE, CA 96150

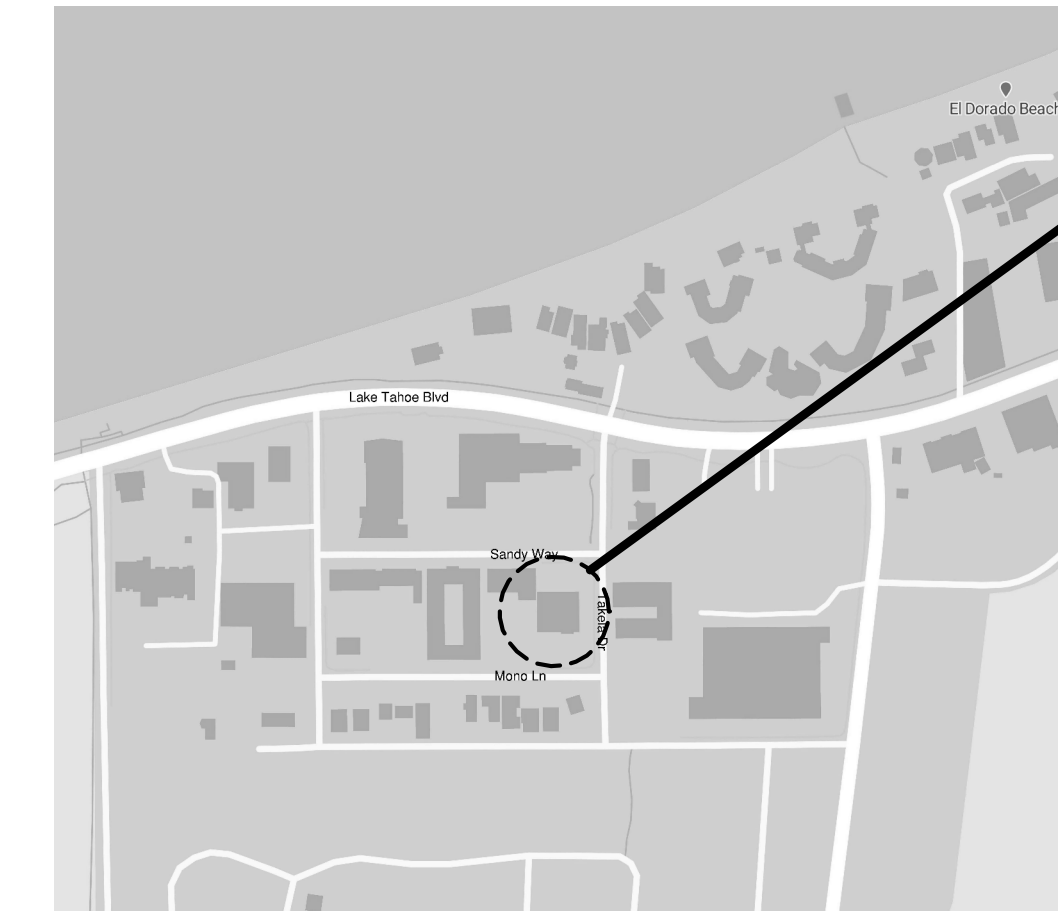

PROJECT LOCATION

VINCINITY MAP

Nexus Project #: 18117

Owner Project #:

01.02.2019

CONSTRUCTION DOCUMENTS

OWNER

COUNTY OF EL DORADO

3000 Fairlane Court, Suite 1 Placerville, CA 95667

CONTACT: DAN EVANS PHONE: 530.621.5836

E-MAIL: INTERNET:



ARCHITECT ARCHITECTURAL NEXUS, INC.

930 R St Sacramento, CA 95811

CONTACT: Richard Price PHONE: 916.642.8425

E-MAIL: rprice@archnexus.com INTERNET: http://www.archnexus.com

MECHANICAL & PLUMBING CAPITAL ENGINEERING

11020 Sun Center Drive, Suite 100 Rancho Cordova, CA 95670

CONTACT: Kevin Stillman PHONE: 916.851.3500

E-MAIL: kstillman@capital-engineering.com INTERNET: www.capital-engineering.com

ELECTRICAL THE ENGINEERING ENTERPRISE

1125 High St Auburn, CA 95603

CONTACT: Andy Bell PHONE: 530.927.5791

E-MAIL: andy@engent.com INTERNET:

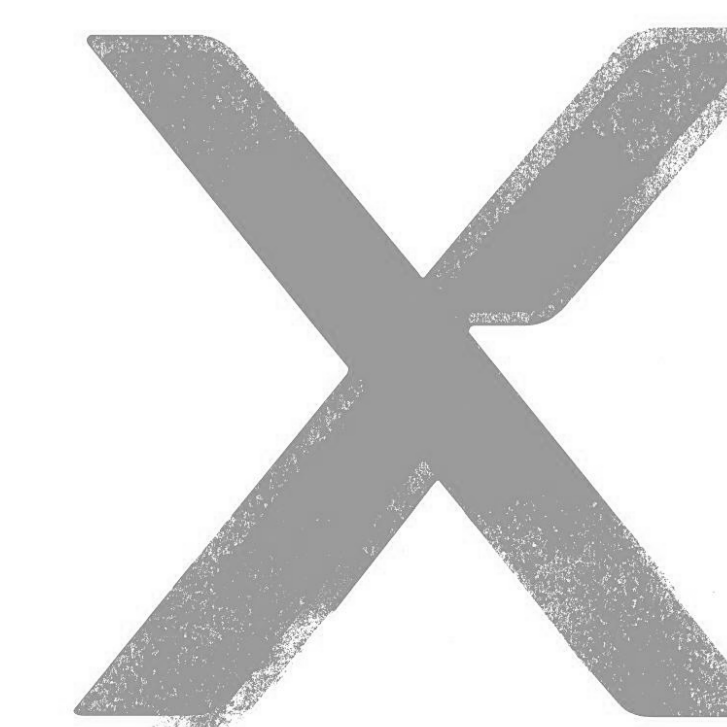

ARCH | NEXUS

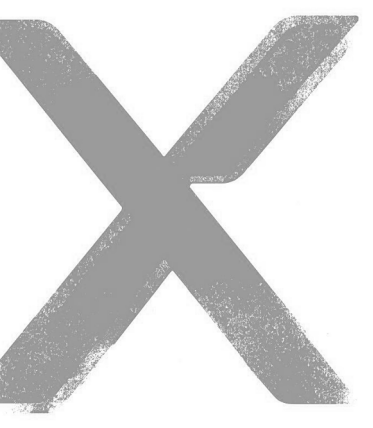

ARCH | NEXUS

Architectural NEXUS, Inc. 930 R Street Sacramento, California 95811 T 916.443.5911 http://www.archnexus.com

Original drawings remain the property of the Architect and as such the Architect retains total ownership and control. The design represented by these drawings is sold to the client for a one time use, unless otherwise agreed upon in writing by the Architect. © Architectural Nexus, Inc. 2014



COUNTY OF EL DORADO HHSA TENANT IMPROVEMENT 3368 SANDY WAY SOUTH LAKE TAHOE, CA 96150

# Date Revision

CONSTRUCTION DOCUMENTS

NEXUS PROJ. #: 18117 CHECKED BY: RP DRAWN BY: MR/CJ DATE: 01.02.2019

COVER SHEET

G001 18-1912 Revised B 75 of 606 BOS Rcvd 1-24-19

**LIST OF ABBREVIATIONS**

<b>A</b>	AIR CONDITIONING	<b>G</b>	GAUGE	<b>R</b>	RISER OR RADIUS
AC	AREA DRAIN	GA	GALVANIZED	RAD	RADIUS
AD	ABOVE FINISHED CEILING	GALV	GLASS-FIBER-REINFORCED	RCP	REFLECTED CEILING PLAN
AFC	ABOVE FINISHED FLOOR	GFRG	CONCRETE	RD	ROOF DRAIN
AFF	AIR HANDLING UNIT	GFRG	GLASS-FIBER-REINFORCED GYPSUM	REF	REFRIGERATOR
AHU	AIR HANDLING UNIT	GL	GLASS	REQD	REQUIRED
ALUM	ALUMINUM	GMB	GYPSUM WALL BOARD	REV	REVISION
ANOD	ANODIZED	GYP	GYPSUM	RH	RELATIVE HUMIDITY
ARCH	ARCHITECT			RM	ROOM
@	AT			RO	ROUGH OPENING
		<b>H</b>	HIGH	RTU	ROOF TOP UNIT
<b>B</b>	BOARD	HB	HOSE BIBB	RWL	RAIN WATER LEADER
BD	BUILDING	HDR	HEADER		
BLDG	BUILDING	HM	HOLLOW METAL		
BO	BOTTOM OF	HPT	HIGH POINT		
		HR	HOUR		
		HT	HEIGHT		
<b>C</b>	CELSIUS			<b>S</b>	SMOKE DETECTOR
CH	COAT HOOK			SAM	SELF ADHESIVE MEMBRANE
CFI	CONTRACTOR FURNISHED, CONTRACTOR INSTALLED	<b>I</b>	INSIDE DIAMETER, INSIDE DIMENSION	SCHED	SCHEDULE
CG	CORNER GUARD	ID	INSIDE DIAMETER, INSIDE DIMENSION	SECT	SECTION
CJ	CONTINUOUS INSULATION	IN	INCH	SIM	SIMILAR
CI	CONTROL JOINT	INFO	INFORMATION	SPEC	SPECIFICATION
CL	CENTERLINE	INT	INTERIOR	SS	STAINLESS STEEL
CLG	CEILING			STD	STANDARD
CLO	CLOSET	<b>J</b>	JANITOR	STRUCT	STRUCTURAL
CLR	CLEAR	JAN	JANITOR		
CMU	CONCRETE MASONRY UNIT	<b>K</b>	(NOT USED)	<b>T</b>	TREAD
COL	COLUMN			TEL	TELEPHONE
CONC	CONCRETE			TEMP	TEMPORARY
CONT	CONTINUOUS	<b>L</b>	LABORATORY	THK	THICK
CORR	CORRIDOR	LAV	LAVATORY	TOC	TOP OF CONCRETE
CT	CERAMIC TILE	LBS	POUNDS	TOM	TOP OF MASONRY
CTJ	CONSTRUCTION JOINT	LLH	LONG LEG HORIZONTAL	TOP	TOP OF PARAPET
CUH	CABINET UNIT HEATER	LLV	LONG LEG VERTICAL	TOS	TOP OF SLAB, TOP OF STEEL
		LPT	LOW POINT	TOW	TOP OF WALL
				TP	TYPICAL
<b>D</b>	DEEP			TO	TOP OF
DG	DEGREE	<b>M</b>	MACHINE ROOM		
DEMO	DEMOLITION	MACH RM	MACHINE ROOM	<b>U</b>	UNDERWRITER'S LABORATORIES
DF	DRINKING FOUNTAIN	MAX	MAXIMUM	UL	UNLESS NOTED OTHERWISE
DIA	DIAMETER	MFR	MANUFACTURER	UNO	
DM	DIMENSION	MECH	MECHANICAL		
DN	DOWN	MEZZ	MEZZANINE	<b>V</b>	VINYL COMPOSITE TILE
DS	DOWNSPROUT	MIN	MINIMUM	VCT	VERTICAL
DMSS	DRAWINGS	MO	MASONRY OPENING	VERT	VESTIBULE
				VIF	VERIFY IN FIELD
<b>E</b>	EXISTING	<b>N</b>	NEW	<b>W</b>	WITH
EA	EACH	(N)	NEW	WO	WITHOUT
EJ	EXPANSION JOINT	NA	NOT APPLICABLE	WD	WOOD
EIFS	EXTERIOR INSULATION AND FINISH SYSTEM	NIC	NOT IN CONTRACT	WH	WALL HYDRANT
EL	ELEVATION	NOM	NOMINAL	WP	WORKING POINT
ELEC	ELECTRICAL	NTS	NOT TO SCALE	WRB	WEATHER RESISTIVE BARRIER
ELEV	ELEVATOR			<b>XYZ</b>	(NOT USED)
EOS	EDGE OF SLAB	<b>O</b>	ON CENTER		
ERD	EXISTING ROOF DRAIN	OC	OUTSIDE DIAMETER		
EQ	EQUAL	OD	OUTSIDE DIAMETER		
EQUIP	EQUIPMENT	OFD	OVERFLOW DRAIN		
EWC	ELECTRIC WATER COOLER	OH DR	OVERHEAD DOOR		
EXIST	EXISTING	OPH	OPPOSITE HAND		
EXP	EXPOSED	OPP	OPPOSITE		
EXT	EXTERIOR	ORIG	ORIGINAL		
		<b>P</b>	PLASTIC LAMINATE		
<b>F</b>	FAHRENHEIT	PLAM	PLASTIC LAMINATE		
FA	FIRE ALARM	PLAS	PLASTER		
FACP	FIRE ALARM CONTROL PANEL	PLUMB	PLUMBING		
FDC	FIRE DEPARTMENT CONNECTION	PR	PAIR		
FD	FLOOR DRAIN	PSI	POUNDS PER SQUARE INCH		
FEC	FIRE EXTINGUISHER CABINET	PSF	POUNDS PER SQUARE FOOT		
FE	FIRE EXTINGUISHER	PVC	POLYVINYL CHLORIDE		
FG	FINISH GRADE				
FHC	FIRE HOSE CABINET	<b>Q</b>	QUARRY TILE		
FIN	FINISH	QT	QUARRY TILE		
FLR	FLOOR				
FND	FOUNDATION				
FO	FINISHED OPENING				
FOC	FACE OF CONCRETE				
FOM	FACE OF MASONRY				
FOS	FACE OF STUD				
FOW	FACE OF WALL				
FRG	FIBER REINFORCED GYPSUM				
FSP	FIRE STANDPIPE				
FT	FEET				
FV	FIELD VERIFY				

**DRAWING SYMBOL LEGEND**

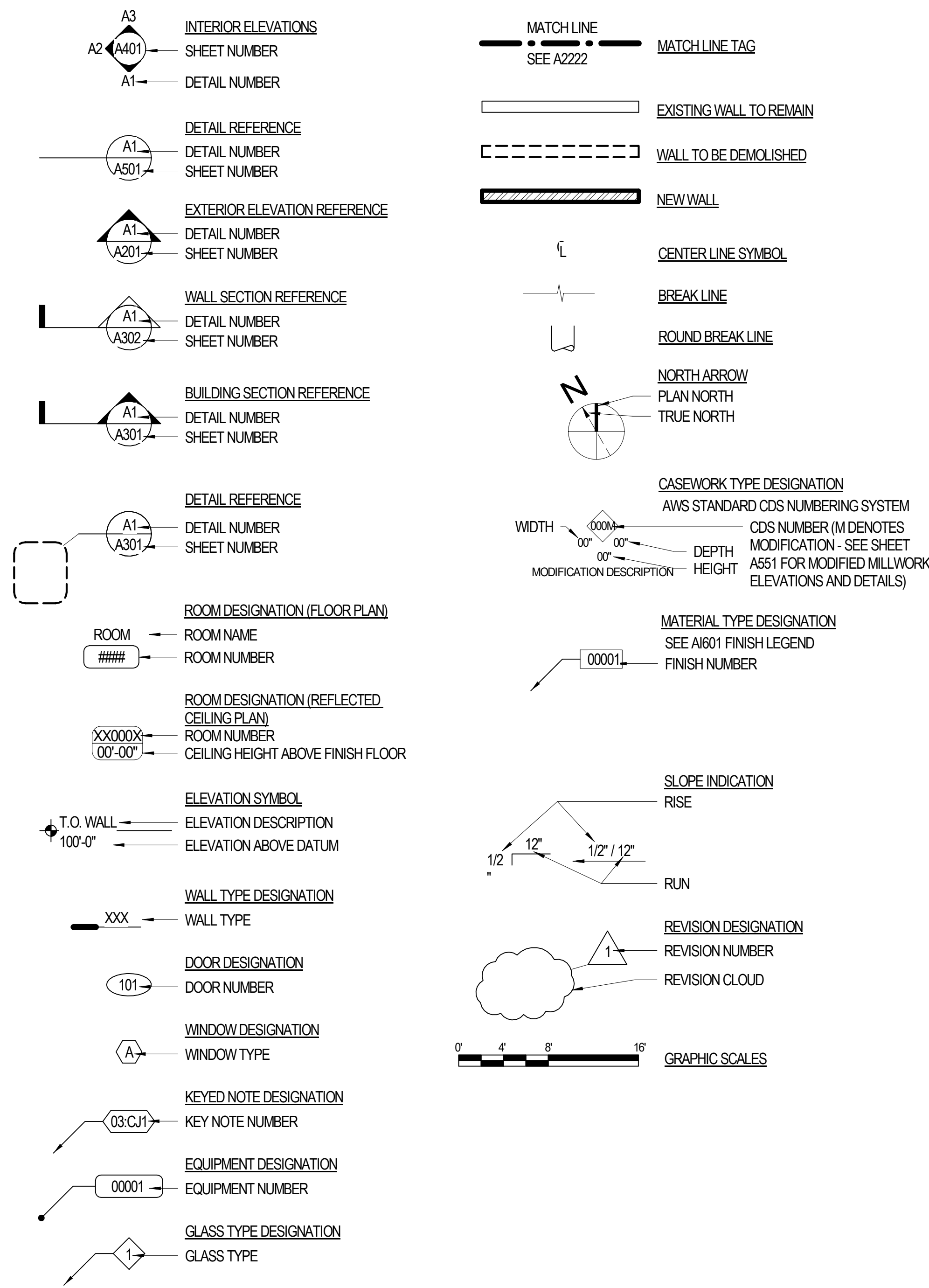

**HATCH LEGEND**

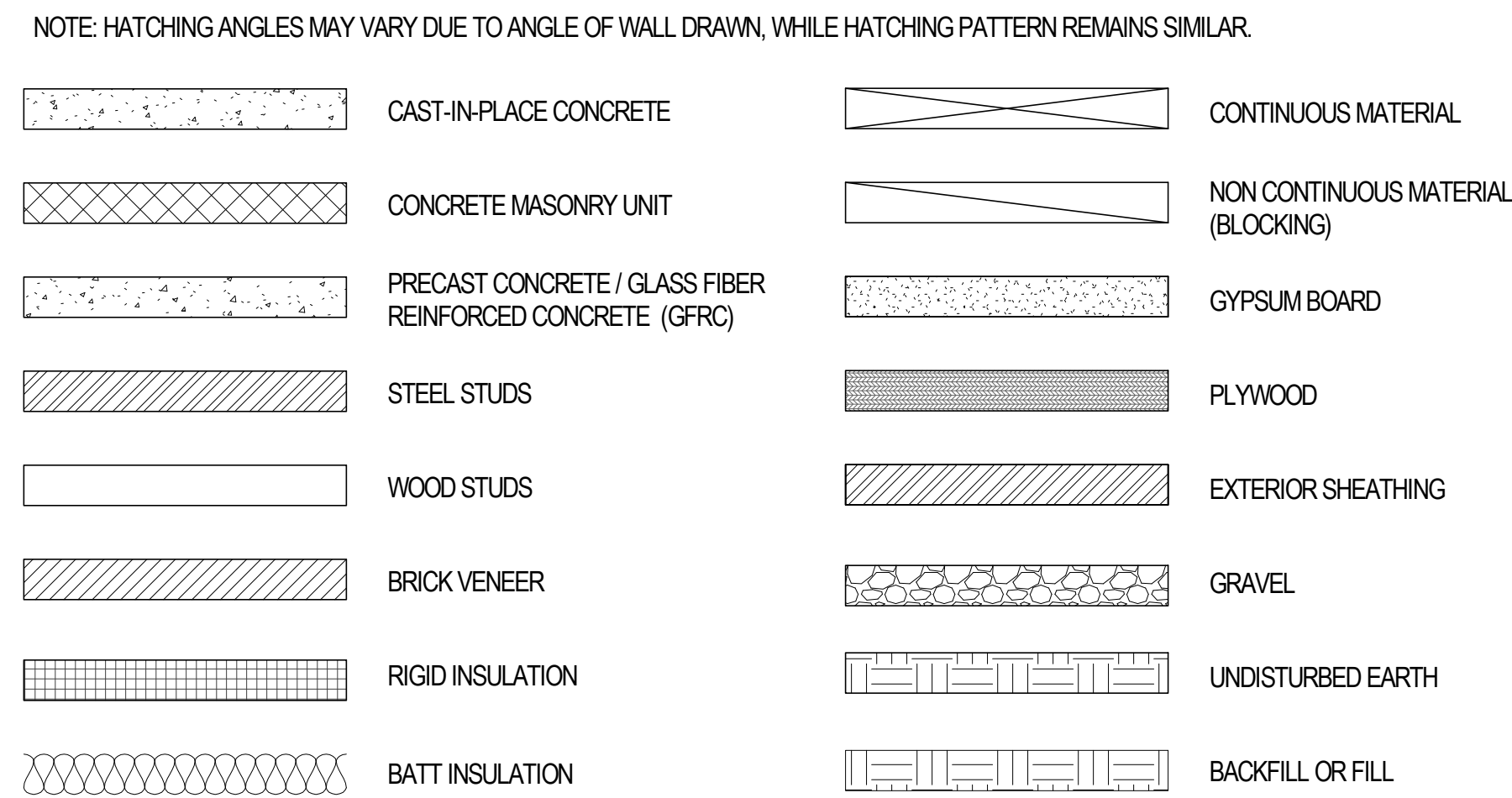

**DESIGN CRITERIA**

**APPLICABLE CODES**

ACCESSIBILITY CODE	CBC CHAPTER 11B 2016 EDITION
CALIFORNIA BUILDING CODE	2016 EDITION
CALIFORNIA ENERGY CONSERVATION CODE	2016 EDITION
CALIFORNIA FIRE CODE	2016 EDITION
CALIFORNIA MECHANICAL CODE	2016 EDITION
CALIFORNIA PLUMBING CODE	2016 EDITION
CALIFORNIA ELECTRICAL CODE	2016 EDITION
ZONING ORDINANCE:	South Lake Tahoe Zoning Ordinance

**PROJECT SCOPE**

- TENANT IMPROVEMENT OF EXISTING BUILDING, REFURBISH INTERIOR
- SPACE TO ACCOMMODATE A NEW OFFICE SPACE. NO SITE WORK - NIC.

**DEFERRED SUBMITTALS**

FIRE ALARM	

**SHEET INDEX**

<b>GENERAL:</b>	
G001	COVER SHEET
G101	EXITING AND OCCUPANCY PLANS
G501	ASSEMBLY TYPES & DETAILS
G701	ACCESSIBILITY COMPLIANCE
G002	GENERAL INFORMATION
<b>ARCHITECTURAL:</b>	
AS101	ARCHITECTURAL SITE PLAN
AD101	DEMOLITION PLAN
A101	FLOOR PLAN
A102	ALTERNATES
A121	ROOF PLAN
A151	REFLECTED CEILING PLAN
A201	BUILDING ELEVATIONS
A251	INTERIOR ELEVATIONS
A252	INTERIOR ELEVATIONS
A301	BUILDING SECTIONS
A501	DETAILS
A601	WINDOW AND DOOR SCHEDULES AND DETAILS
A602	WINDOW DETAILS
A701	TYPICAL DETAILS
A1601	FINISH PLAN
A1602	FINISH & FIXTURE SCHEDULES
<b>MECHANICAL:</b>	
M000	HVAC LEGENDS AND NOTES
M001	HVAC SCHEDULES
M002	TITLE 24 COMPLIANCE
M100	HVAC DEMO PLAN
M101	HVAC FLOOR PLAN
M201	HVAC ROOF PLAN
M500	HVAC DETAILS
P000	PLUMBING LEGENDS, NOTES, AND SCHEDULES
P001	PLUMBING SCHEDULES
P100	PLUMBING DEMO PLAN
P101	PLUMBING FLOOR PLAN
P500	PLUMBING DETAILS
<b>ELECTRICAL:</b>	
E000	SYMBOLS, ABBREVIATIONS AND SHEET INDEX
E001	PROJECT NOTES AND SCHEDULES
E002	LOW VOLTAGE INSTRUCTIONS & SPECS
E003	TITLE 24
E100	DEMO PLAN
E200	LIGHTING PLAN
E300	POWER & SIGNAL PLAN
E301	POWER & SIGNAL PLAN ROOF
E400	FIRE ALARM PLAN
E500	POWER ON-LINE DIAGRAM
E501	RISER DIAGRAMS
E600	POWER ONE-LINE DIAGRAM
E601	DETAILS

**ALTERNATES**

**ADDITIVE ALTERNATE #1: REPLACE EXISTING WINDOWS**

1. BASE BID: NO WORK ASSOCIATED WITH EXISTING EXTERIOR WINDOWS, TYPICAL OF FIVE LOCATIONS.
2. ADDITIVE ALTERNATE: REMOVE EXISTING PUNCHED WINDOWS AND REPLACE WITH NEW FIXED, INSULATED LOW-E REFLECTIVE GLAZING IN ALUMINUM WINDOW FRAMES TO MATCH STOREFRONT SYSTEM. WORK INCLUDES REMOVING ADJACENT EXTERIOR WOOD TRIM, INSTALLING FLASHING AND RE-INSTALLING WOOD TRIM AS NECESSARY FOR WATERTIGHT INSTALLATION. TYPICAL OF FIVE. WATER TEST (HOSE STREAM) TO BE PERFORMED ON ALL WINDOWS. SEE FLOOR PLAN FOR EXACT LOCATION.

**DEDUCTIVE ALT #2: RE-USE EXISTING PEX PLUMBING PIPING**

1. BASE BID: REMOVE AND REPLACE PREVIOUSLY INSTALLED PEX PLUMBING PIPING IN ITS ENTIRETY. INSTALL NEW COPPER IN WALLS AND CEILING CAVITY PER ISOMETRIC. EXISTING PEX UNDERGROUND WALL REMAIN. MAKE CONNECTION AS NEEDED.
2. DEDUCTIVE ALTERNATE: TEST EXISTING PEX PLUMBING PIPING TO CONFIRM FUNCTIONALITY. IF FOUND TO HAVE NO LEAKS AND TO BE IN LIKE NEW CONDITION, LEAVE IN PLACE/CONTINUE USE OF PEX SYSTEM FOR NEW PLUMBING FIXTURES. CONTRACTOR TO FULLY WARRANTY SYSTEM AS IF NEW.

**DEDUCTIVE ALT #3: LOADING DOCK ENCLOSURE**

1. BASE BID: ENCLOSE COVERED LOADING DOCK WITH STOREFRONT SYSTEM. INFILL BUILD OUT OFFICE 119 & 120 (405 SF) AND ASSOCIATED MECHANICAL AND ELECTRICAL SYSTEMS
2. DEDUCTIVE ALTERNATE: LEAVE LOADING DOCK IN PLACE. DO NOT ENCLOSE/BUILD OUT NEW OFFICES. INFILL EXISTING EXTERIOR DOUBLE DOOR w/ NEW STOREFRONT. REKEY, PAINT TWO (2) DOORS & FRAMES TO REMAIN. PROVIDE (N) HARDWARE AT EXIT DOOR w/ ACCESS CONTROL. (N) GUARDRAIL O/OI. SEE FLOOR PLAN FOR MORE INFORMATION.

**DEDUCTIVE ALT #4: UNISEX STAFF RESTROOM (65 SF)**

1. BASE BID: BUILD OUT ROOM 116 AS UNISEX TOILET ROOM. INCLUDE SINK, RELATED PLUMBING AND TOILET ROOM ACCESSORIES.
2. DEDUCTIVE ALTERNATE: OMIT TOILET, SINK, ASSOCIATED PLUMBING AND ACCESSORIES FROM SCOPE. FINISH ROOM TO MATCH ROOM 124, INCLUDING REVISION OF DOOR HARDWARE. SEE FLOOR PLAN FOR MORE INFORMATION.

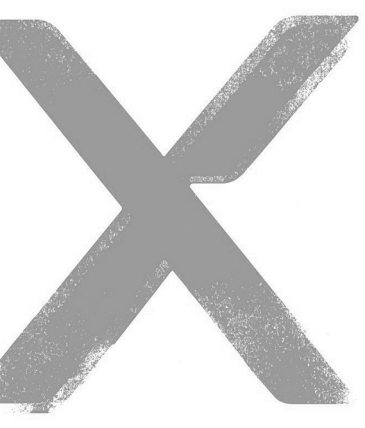

ARCH | NEXUS

Architectural NEXUS, Inc.  
930 R Street  
Sacramento, California 95811  
T 916.443.5911  
http://www.archnexus.com

Original drawings remain the property of the Architect and as such the Architect retains total ownership and control. The design represented by these drawings is sold to the client for a one time use, unless otherwise agreed upon in writing by the Architect. ©Architectural Nexus, Inc. 2014



COUNTY OF EL DORADO  
**HHSA TENANT IMPROVEMENT**  
3368 SANDY WAY  
SOUTH LAKE TAHOE, CA 96150

#	Date	Revision
---	------	----------

**CONSTRUCTION DOCUMENTS**

NEXUS PROJ. #: 18117  
CHECKED BY: RP  
DRAWN BY: MR  
DATE: 01.02.2019

**GENERAL INFORMATION**

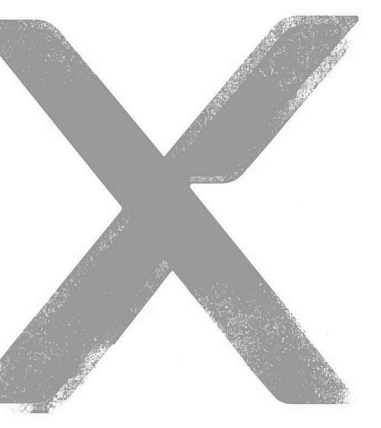

ARCH | NEXUS

Architectural NEXUS, Inc.  
930 R Street  
Sacramento, California 95811  
T 916.443.5911  
http://www.archnexus.com

Original drawings remain the property of the Architect and as such the Architect retains total ownership and control. The design represented by these drawings is sold to the client for a one time use, unless otherwise agreed upon in writing by the Architect. © Architectural Nexus, Inc. 2014



COUNTY OF EL DORADO  
**HHSA TENANT IMPROVEMENT**  
3368 SANDY WAY  
SOUTH LAKE TAHOE, CA 96150

### CBC 2016 - GENERAL CODE REQUIREMENTS EXISTING BUILDING - ALTERATION

CODE REFERENCE	(E) BUILDING	ALTERATION
<b>OCCUPANCY CLASSIFICATION:</b> (CHAPTER 3)	A-2	B
<b>CONSTRUCTION TYPE:</b> (CHAPTER 6)	V-B	V-B
<b>REQUIRED SEPARATION OF OCCUPANCIES (HOURS)</b> (CHAPTER 5 AND CHAPTER 7)		
<b>REQUIRED SEPARATION (NON-SPRINKLERED)</b> <sup>(1) (PER 509)</sup>	0	0
<b>PROVIDED SEPARATION</b>	0	0
<b>ALLOWABLE AREA</b> (SECTION 506 & TABLE 506.2)		
<b>BASE ALLOWABLE AREA (PER FLOOR)</b> (TYPE I-VL, NON-SPRINKLERED)	9000SF	9000SF
<b>ACTUAL AREA</b>	6432SF	6847SF
<b>FIRE RATINGS</b> (TABLE 601.5(2))		
<b>STRUCTURE</b>	0	0
<b>EXTERIOR WALLS</b>	EXISTING - NO CHANGE	EXISTING - NO CHANGE
<b>EGRESS WIDTH</b> (SECTION 1005.3.2)		
<b>DOORWAY WIDTH REQUIRED</b>	N/A	36"
<b>DOORWAY WIDTH PROVIDED</b>	N/A	12'-0"
<b>EXITS</b> (SECTION 1009, TABLE 1009.2)	5	3
<b>YEAR BUILDING WAS CONSTRUCTED:</b>	1964	-
<b>ALLOWABLE BUILDING HEIGHT</b>	N/A	40'-0"
<b>BUILDING HEIGHT IN FEET:</b>	15'-0"	15'-0"
<b>COMPARTMENTATION:</b>	NO	NO
<b>FIRE SPRINKLER:</b>	NO	NO
<b>FIRE ALARM SYSTEM:</b>	N/A	YES
<b>MAXIMUM EXIT ACCESS TRAVEL DISTANCE:</b>	N/A	200'
<b>MAXIMUM COMMON PATH OF EGRESS TRAVEL DISTANCE:</b>	N/A	75'
<b>MEANS OF EGRESS EMERGENCY LIGHTING:</b>	N/A	YES
<b>MIXED OCCUPANCIES:</b>	N/A	NO

### CPC 2016 - FIXTURE REQUIREMENTS

OCCUPANCY BY SPECIFIC USE (PER TABLE 422.1)

WC:	FEMALE	URINAL:	LAVS:	FEMALE
MALE	1:1-25	1:1-100 MALE	MALE	1:1-50
1:1-50	1:1-25	2:101-200	1:1-75	1:1-50
2:51-100	2:26-50		2:76-150	2:51-100
3:201-400	3:51-100			

50% MALE = 65 OCC      50% FEMALE = 65 OCC      DRINKING FOUNTAINS  
 2 WATER CLOSETS REQUIRED      3 WATER CLOSETS REQUIRED      1:1-250  
 1 URINAL REQUIRED      2 LAVATORY REQUIRED

**EXITING AND OCCUPANCY LEGEND**

- > EXIT EGRESS PATH OF TRAVEL
- WALL
- EXISTING WALLS - NO FIRE RATING
- - - EXISTING WALLS - 1 HOUR
- █ NEW WALLS - NO FIRE RATING
- █ NEW WALLS - 1 HOUR
- PH PANIC HARDWARE

ROOM NUMBER	ROOM NAME	AREA	OCC LOAD FACTOR	OCC LOAD
100	VESTIBULE	117 SF	0	0
102	RECEPTION	278 SF	100	3
103	WAITING	317 SF	15	21
104	INTERVIEW BOOTHS	359 SF	100	4
105	WORK BOOTHS	216 SF	0	0
106	CORRIDOR	561 SF	0	0
107	CLIENT RESOURCE OFFICE	232 SF	100	3
108	LARGE CONFERENCE	250 SF	15	17
109	MEETING ROOM	90 SF	15	6
110	JANITOR	113 SF	0	0
111	TOILET	88 SF	0	0
112	MEN'S RESTROOM	146 SF	0	0
113	CORRIDOR	107 SF	0	0
114	WOMEN'S RESTROOM	182 SF	0	0
115	LACTATION	53 SF	0	0
116	UNISEX STAFF RESTROOM	64 SF	0	0
117	BREAK ROOM	180 SF	15	13
118	OPEN OFFICE	2492 SF	100	25
119	OFFICE	142 SF	100	2
120	OFFICE	142 SF	100	2
121	ELECTRICAL / IT / MDF	128 SF	300	0
122	WORK/MAIL	29 SF	0	0
123	LARGE MEETING ROOM	457 SF	15	31
124	CLOSET	22 SF	0	0

TOTAL SQUARE FT = 6847 SF    TOTAL OCCUPANTS = 127

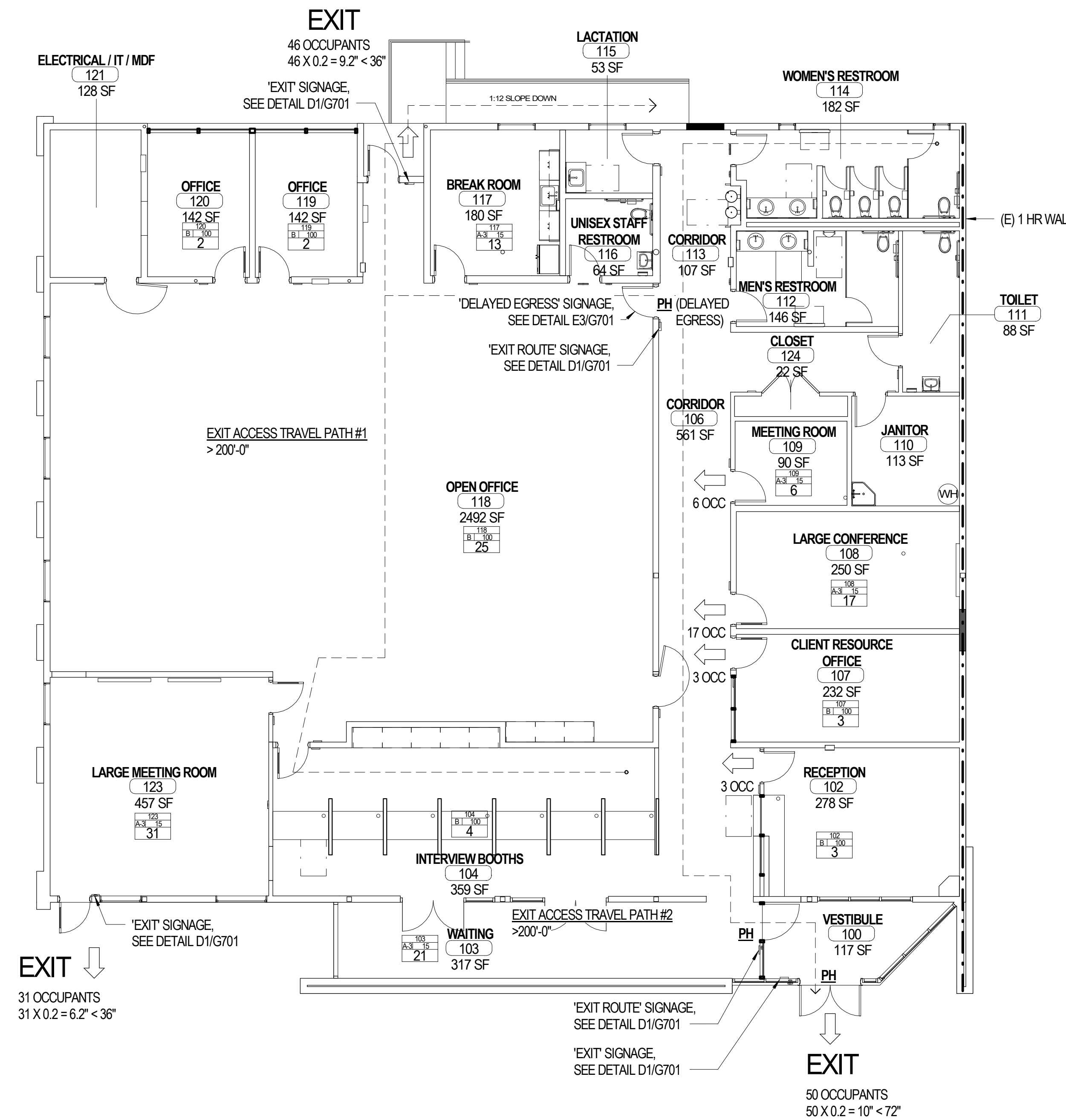

**B1 LEVEL 01 - EXITING AND OCCUPANCY PLANS**  
G101 1/8" = 1'-0"

# Date Revision

### CONSTRUCTION DOCUMENTS

NEXUS PROJ. #: 18117  
CHECKED BY: RP  
DRAWN BY: MR/CJ  
DATE: 01.02.2019

### EXITING AND OCCUPANCY PLANS

**G101**  
18-1912 Revised B 77 of 606  
BOS Rcvd 1-24-19

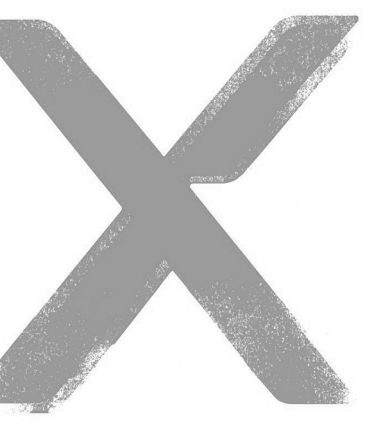

ARCH | NEXUS

Architectural NEXUS, Inc.  
930 R Street  
Sacramento, California 95811  
T 916.443.5911  
http://www.archnexus.com

Original drawings remain the property of the Architect and as such the Architect retains total ownership and control. The design represented by these drawings is sold to the client for a one time use, unless otherwise agreed upon in writing by the Architect. © Architectural Nexus, Inc. 2014



COUNTY OF EL DORADO  
**HHSA TENANT IMPROVEMENT**  
3368 SANDY WAY  
SOUTH LAKE TAHOE, CA 96150

# Date Revision

CONSTRUCTION DOCUMENTS

NEXUS PROJ. #: 18117  
CHECKED BY: RP  
DRAWN BY: MR  
DATE: 01.02.2019

ASSEMBLY TYPES & DETAILS

G501  
18-1912 Revised B 78 of 606  
BOS Rcvd 1-24-19

WALL TYPE:	FIRE RATING:	NONE
<b>W6</b>	FIRE TEST:	N/A
HEIGHT: STRUCTURE ABOVE	SOUND RATING:	N/A
HEAD DETAIL: 8/G501	SOUND TEST:	N/A
SILL DETAIL: C4/A701	SOUND TEST:	N/A

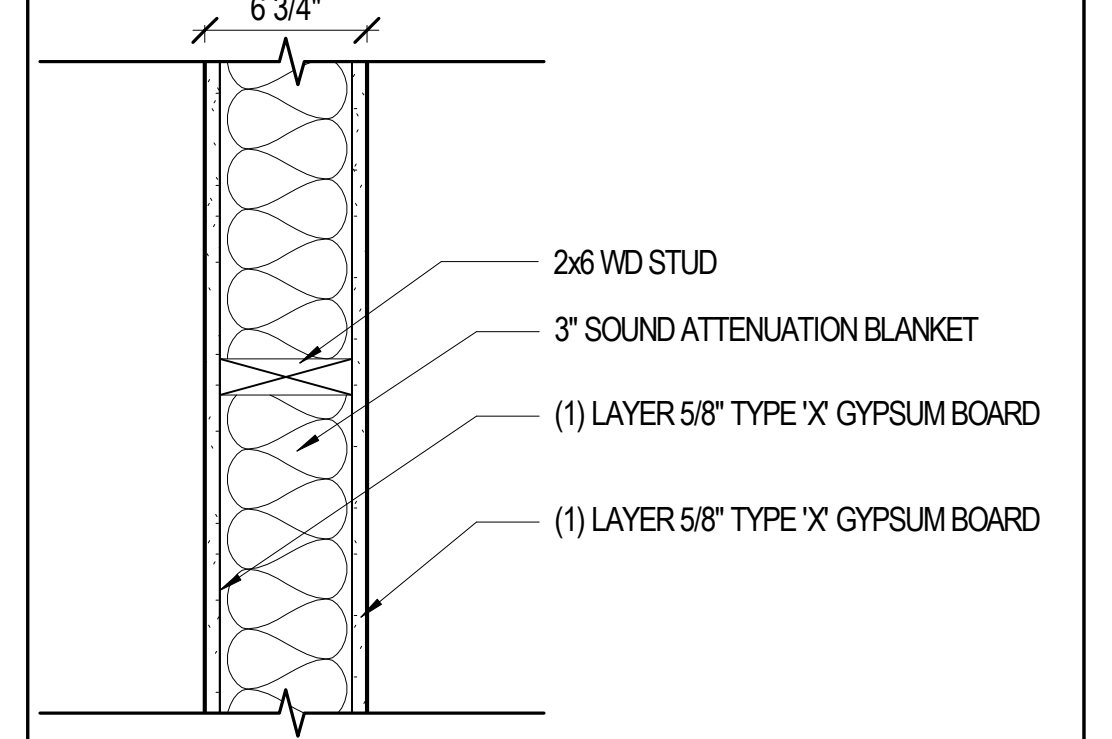

WALL TYPE:	FIRE RATING:	NONE
<b>W6-A50</b>	FIRE TEST:	N/A
HEIGHT: STRUCTURE ABOVE	SOUND RATING:	STC 50
HEAD DETAIL: 8/G501	SOUND TEST:	N/A
SILL DETAIL: C4/A701	SOUND TEST:	N/A

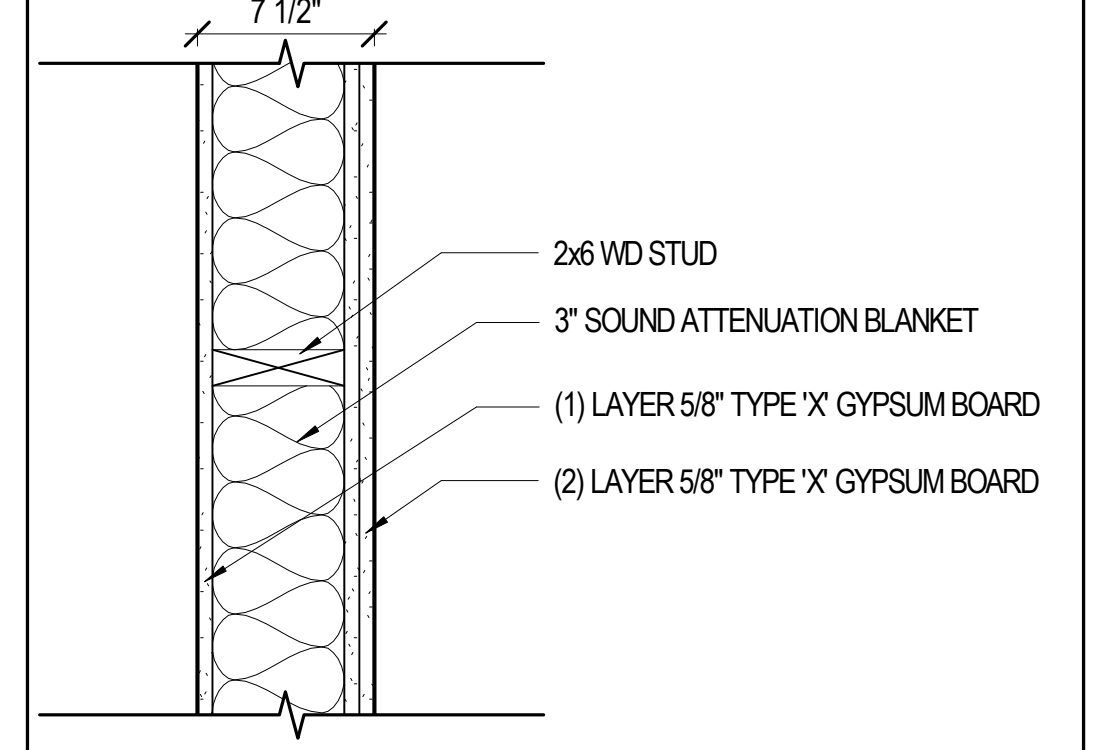

WALL TYPE:	FIRE RATING:	NONE
<b>W4-C</b>	FIRE TEST:	N/A
HEIGHT: 6" ABV CLG	SOUND RATING:	N/A
HEAD DETAIL: E5/A701	SOUND TEST:	N/A
SILL DETAIL: C4/A701	SOUND TEST:	N/A

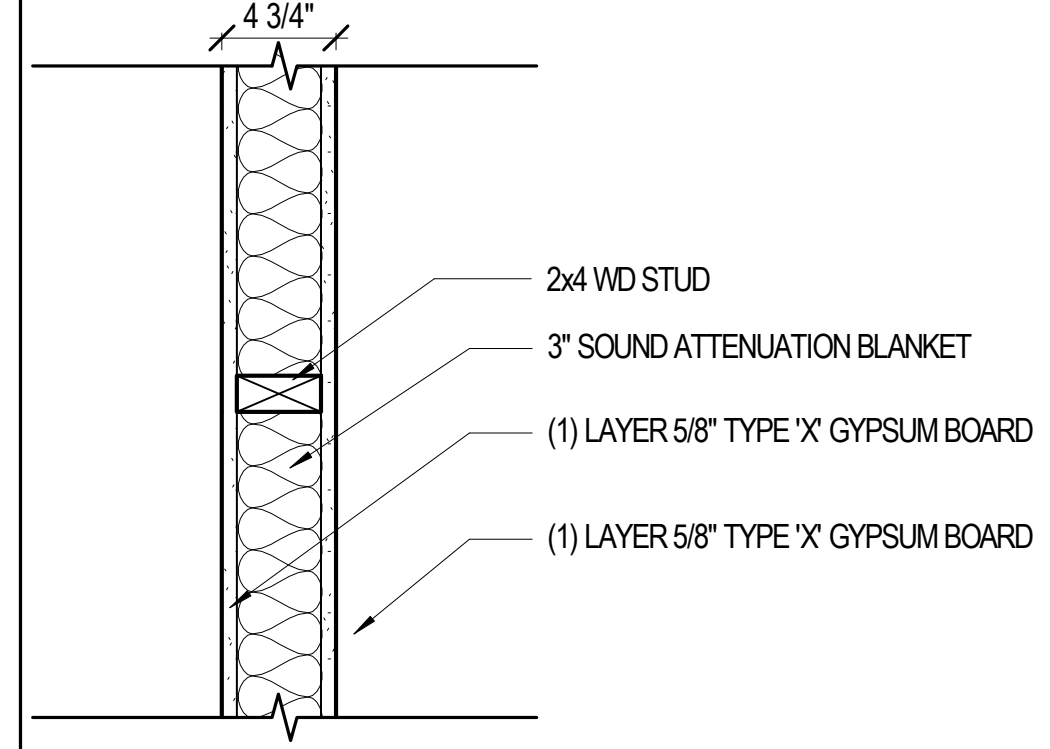

WALL TYPE:	FIRE RATING:	NONE
<b>W4-A50</b>	FIRE TEST:	N/A
HEIGHT: STRUCT ABOVE	SOUND RATING:	STC 50
HEAD DETAIL: 8/G501	SOUND TEST:	N/A
SILL DETAIL: C4/A701	SOUND TEST:	N/A

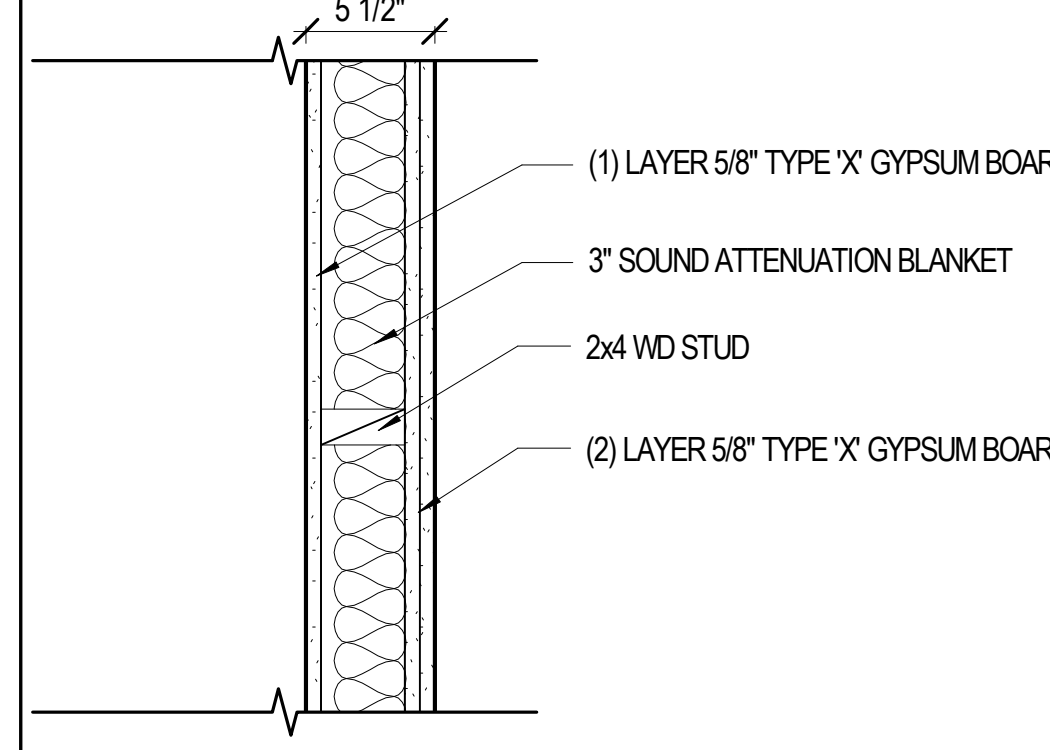

WALL TYPE:	FIRE RATING:	NONE
<b>W6-C</b>	FIRE TEST:	N/A
HEIGHT: 6" ABOVE CLG	SOUND RATING:	N/A
HEAD DETAIL: E5/A701	SOUND TEST:	N/A
SILL DETAIL: C4/A701	SOUND TEST:	N/A

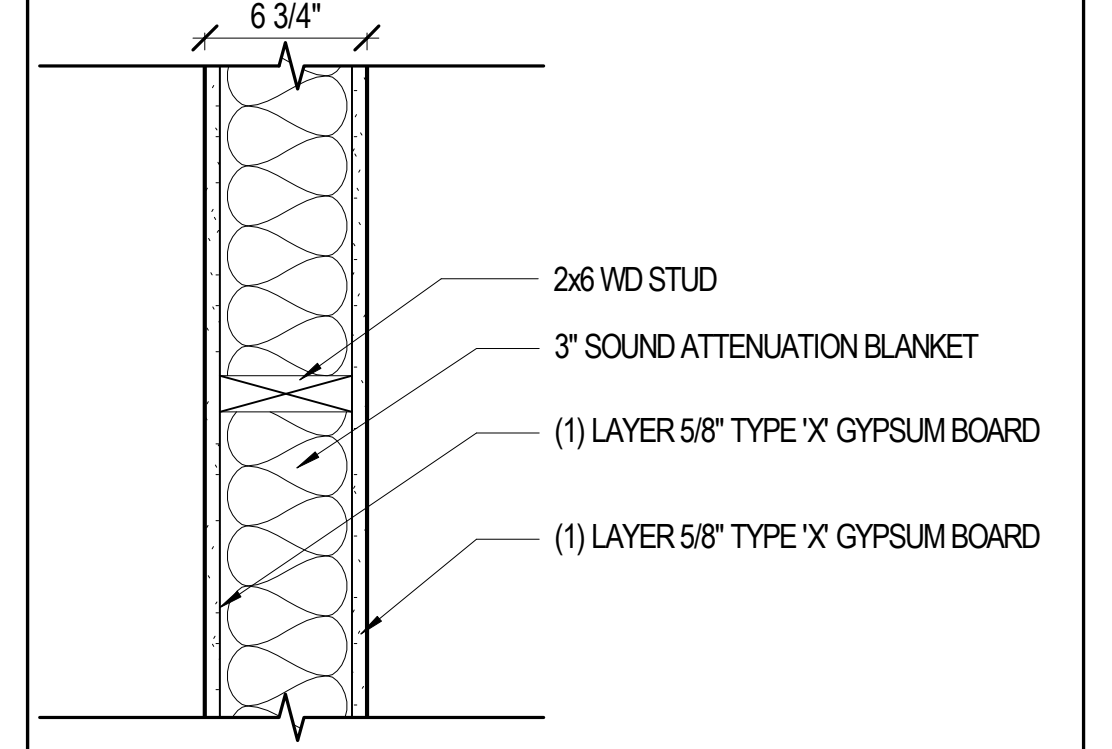

WALL TYPE:	FIRE RATING:	NONE
<b>W4</b>	FIRE TEST:	N/A
HEIGHT: STRUCTURE ABOVE	SOUND RATING:	N/A
HEAD DETAIL: 8/G501	SOUND TEST:	N/A
SILL DETAIL: C4/A701	SOUND TEST:	N/A

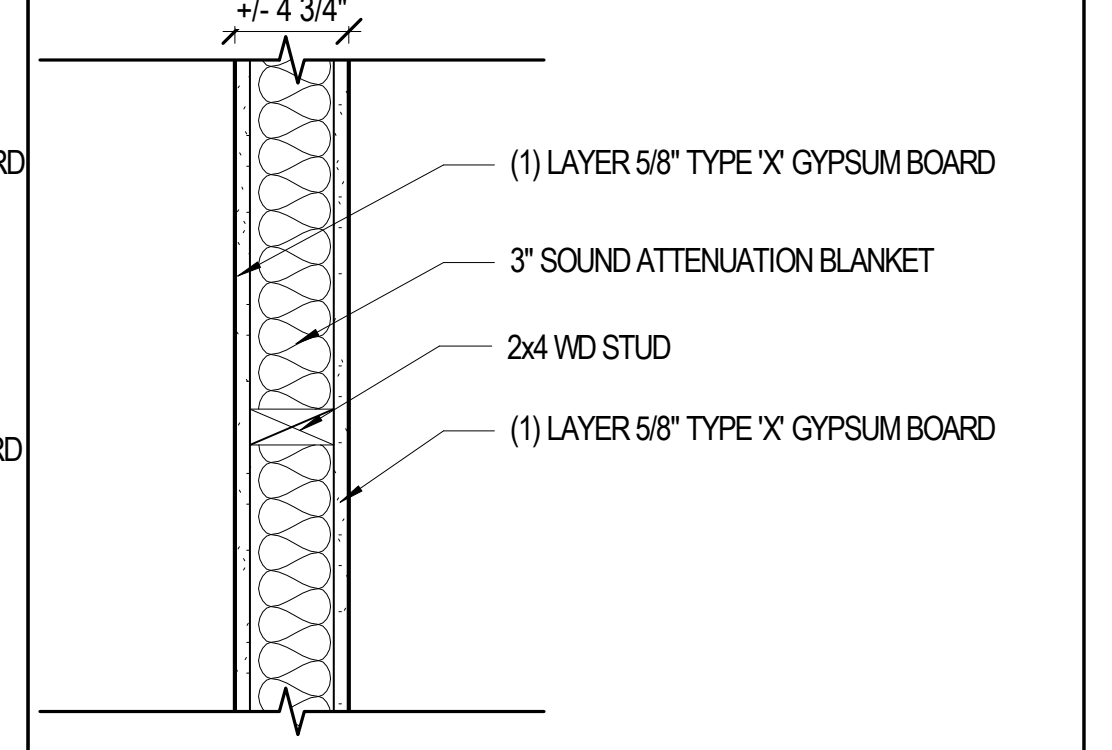

WALL TYPE:	FIRE RATING:	NONE
<b>XW6</b>	FIRE TEST:	-
HEIGHT: VARIES - SEE PLAN	SOUND RATING:	N/A
HEAD DETAIL: 8/G501, UNO	SOUND TEST:	N/A
SILL DETAIL: C4/A701	SOUND TEST:	N/A

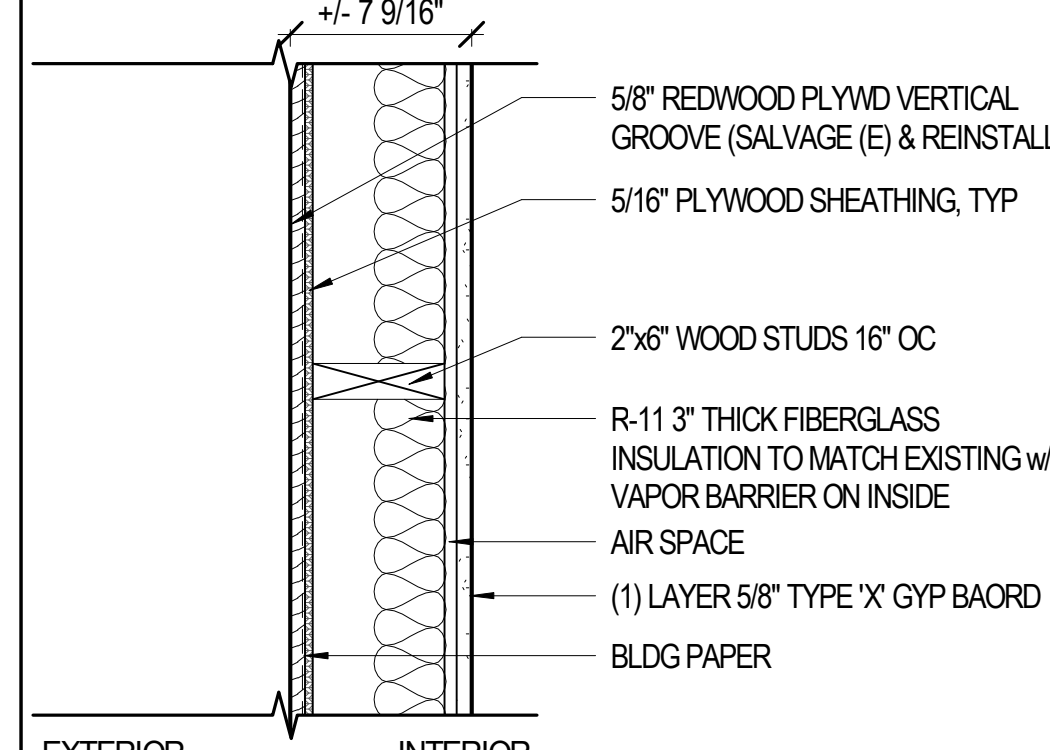

WALL TYPE:	FIRE RATING:	1 HOUR
<b>XW61</b>	FIRE TEST:	SEE PLAN
HEIGHT: INFILL (E) OPENING	SOUND RATING:	N/A
HEAD DETAIL: B1/G501	SOUND TEST:	N/A
SILL DETAIL: B1/G501	SOUND TEST:	N/A

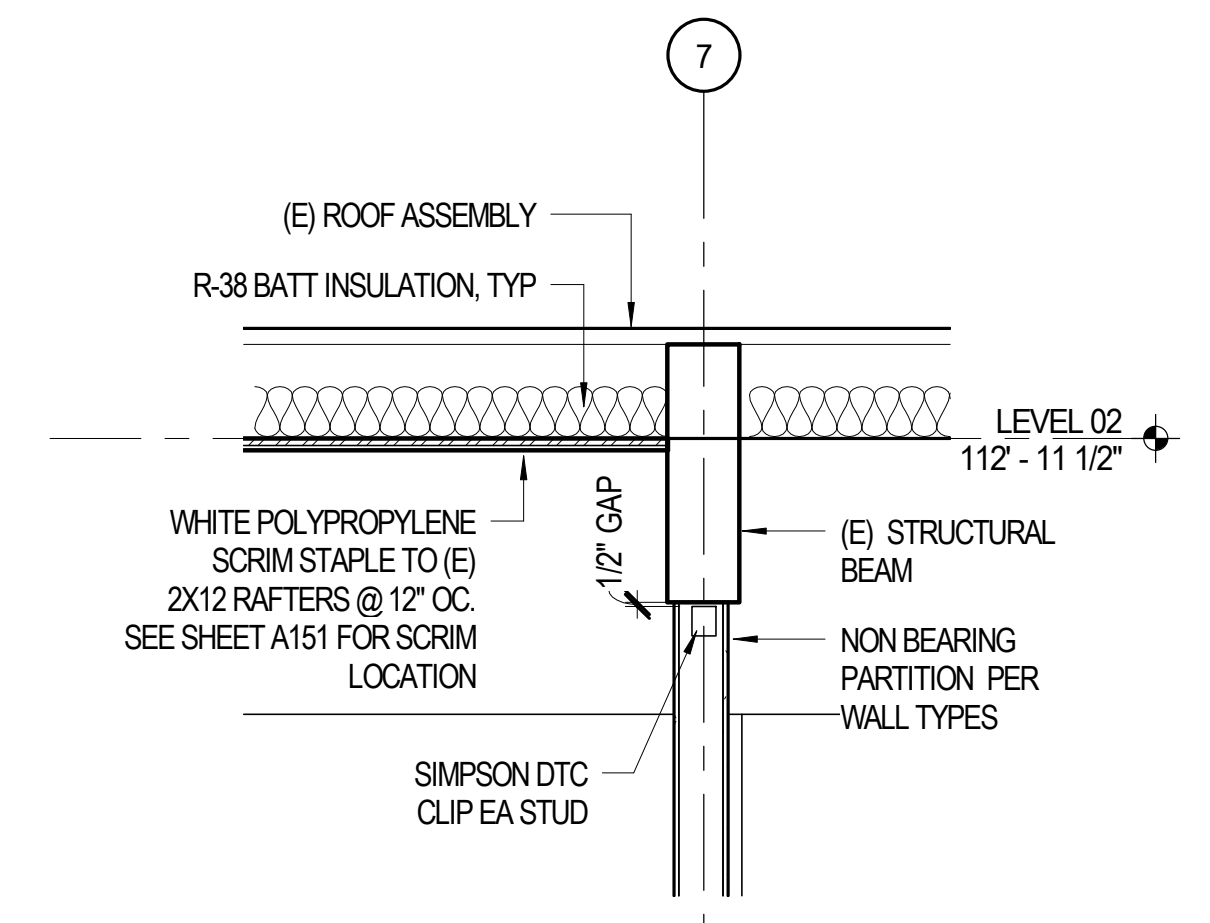
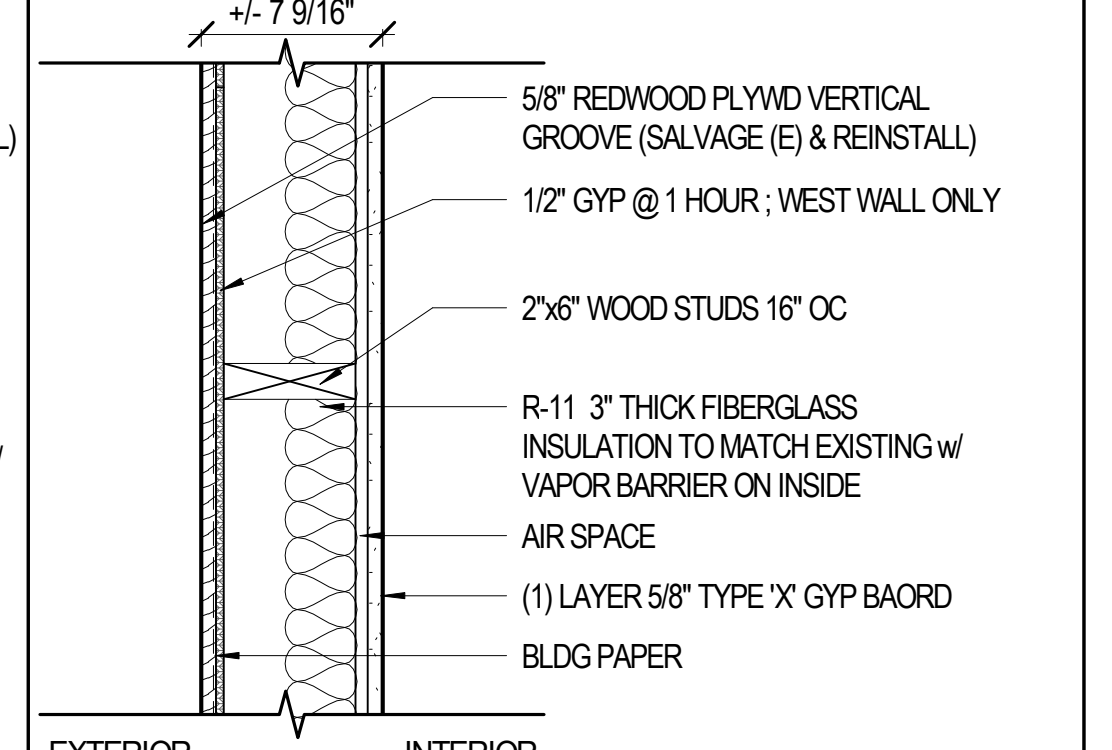

2 (N) WALL TO (E) BEAM  
G501 1/2" = 1'-0"

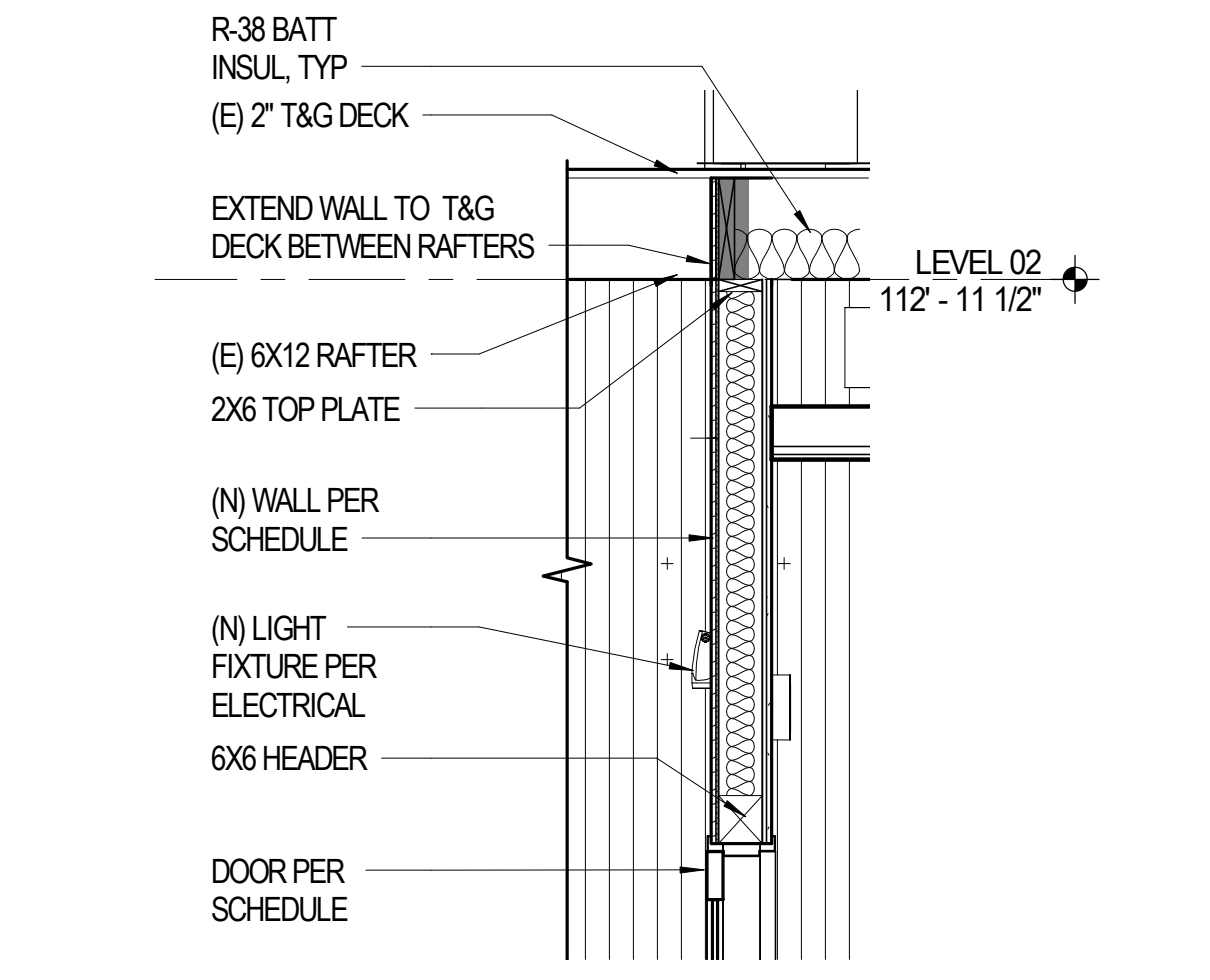

4 WALL SECTION  
G501 1/2" = 1'-0"

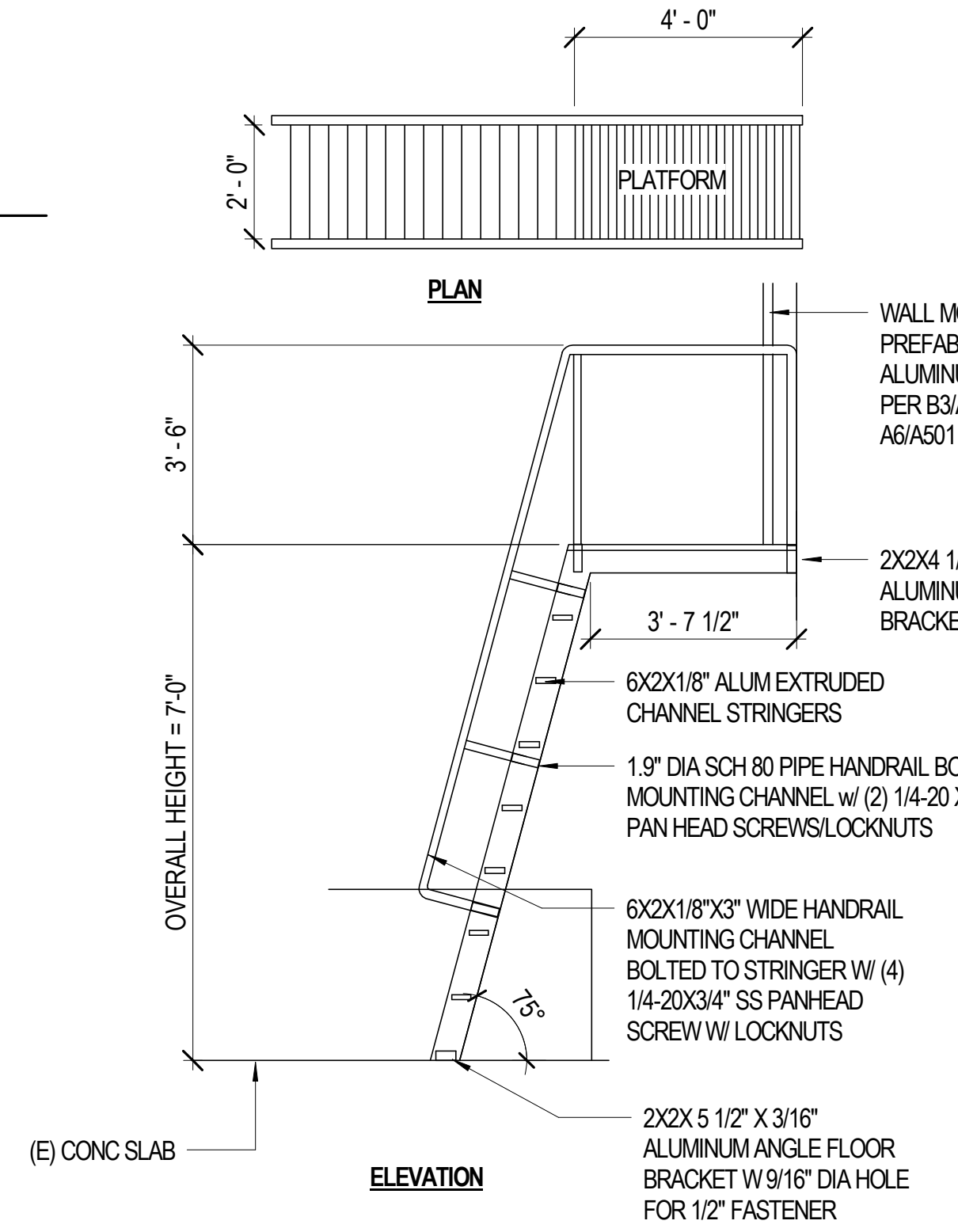

5 SHIPS LADDER WITH LANDING PLATFORM  
G501 3/8" = 1'-0"

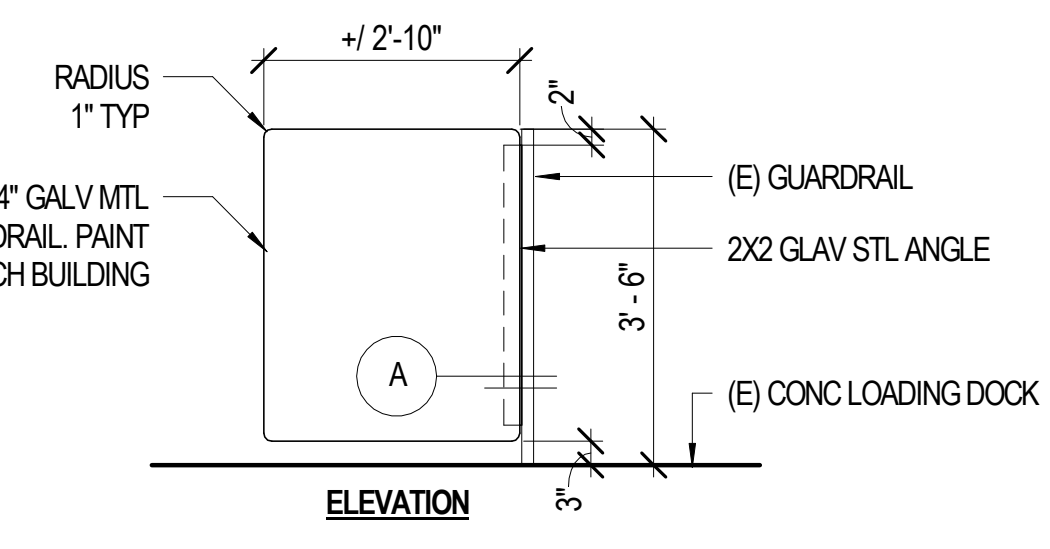
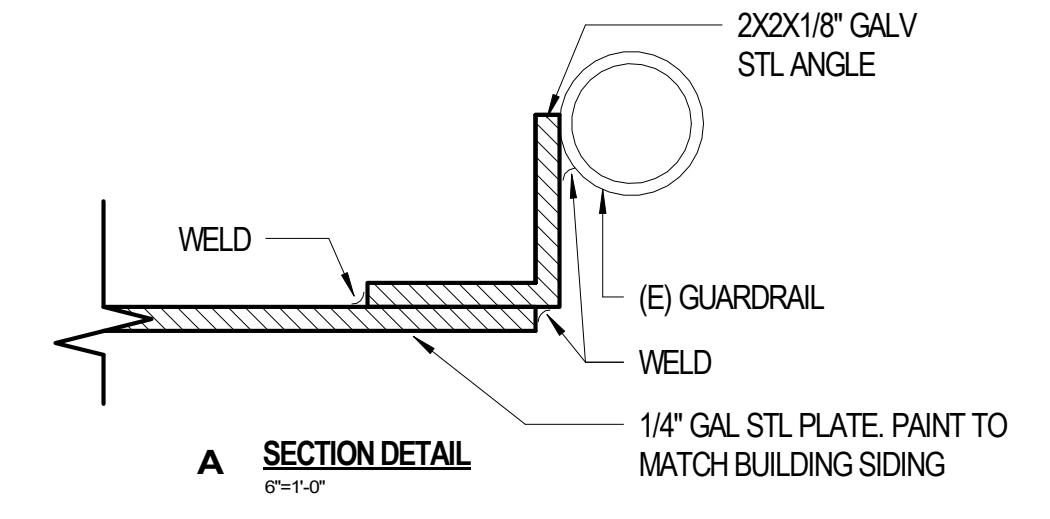

6 GUARDRAIL SOUTH ENTRANCE - OFOI  
G501 1/2" = 1'-0"

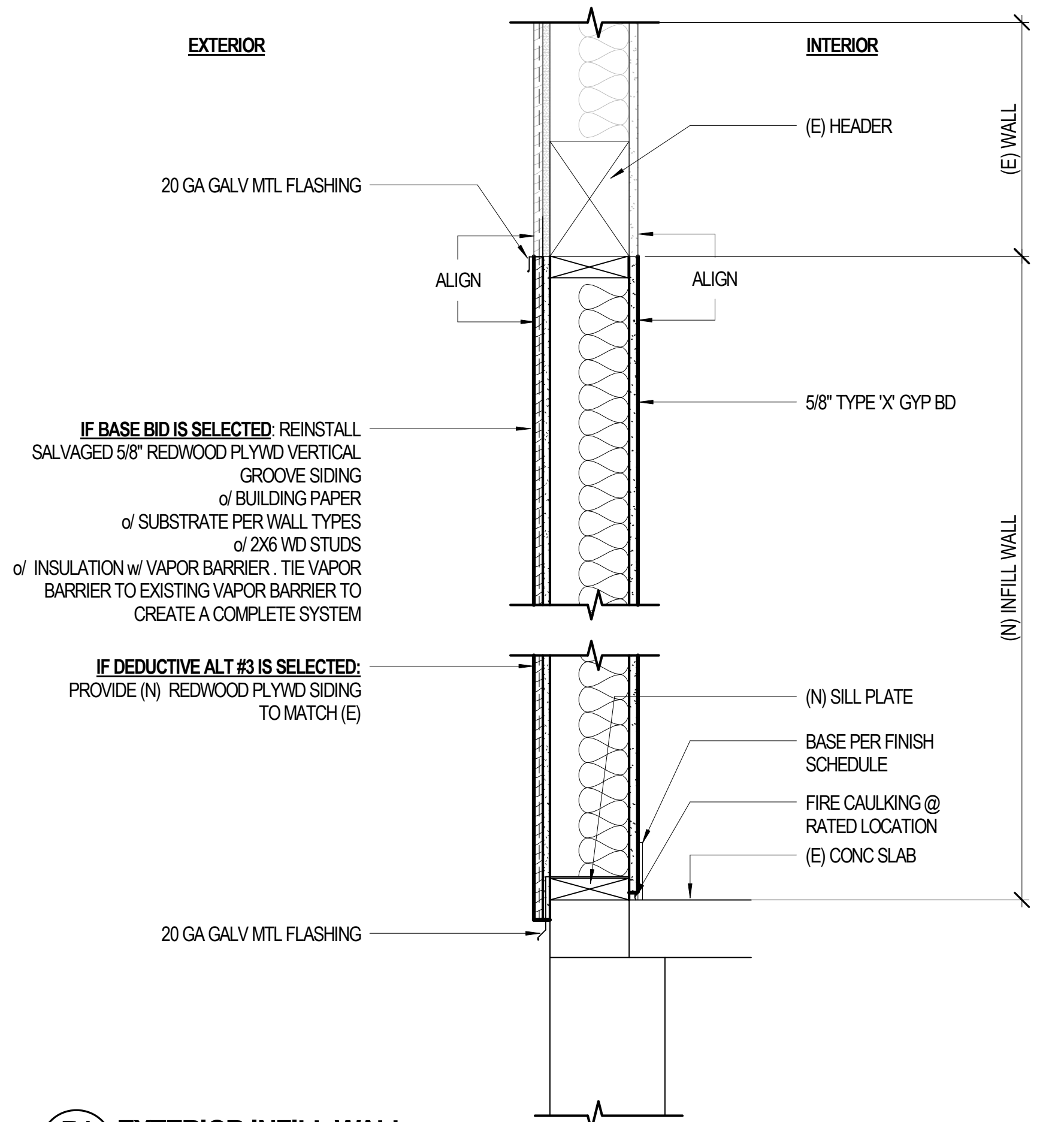

B1 EXTERIOR INFILL WALL  
G501 1 1/2" = 1'-0"

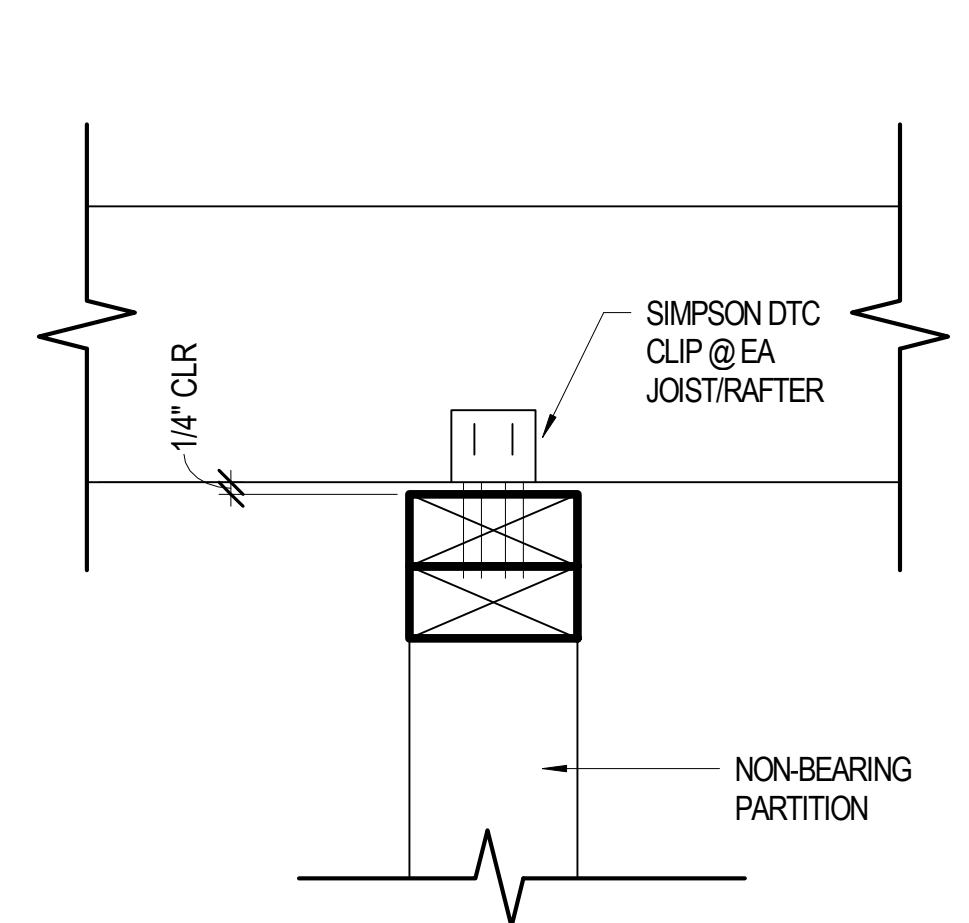

8 NON-BEARING WALL TO JOISTS/RAFTERS  
G501 3" = 1'-0"

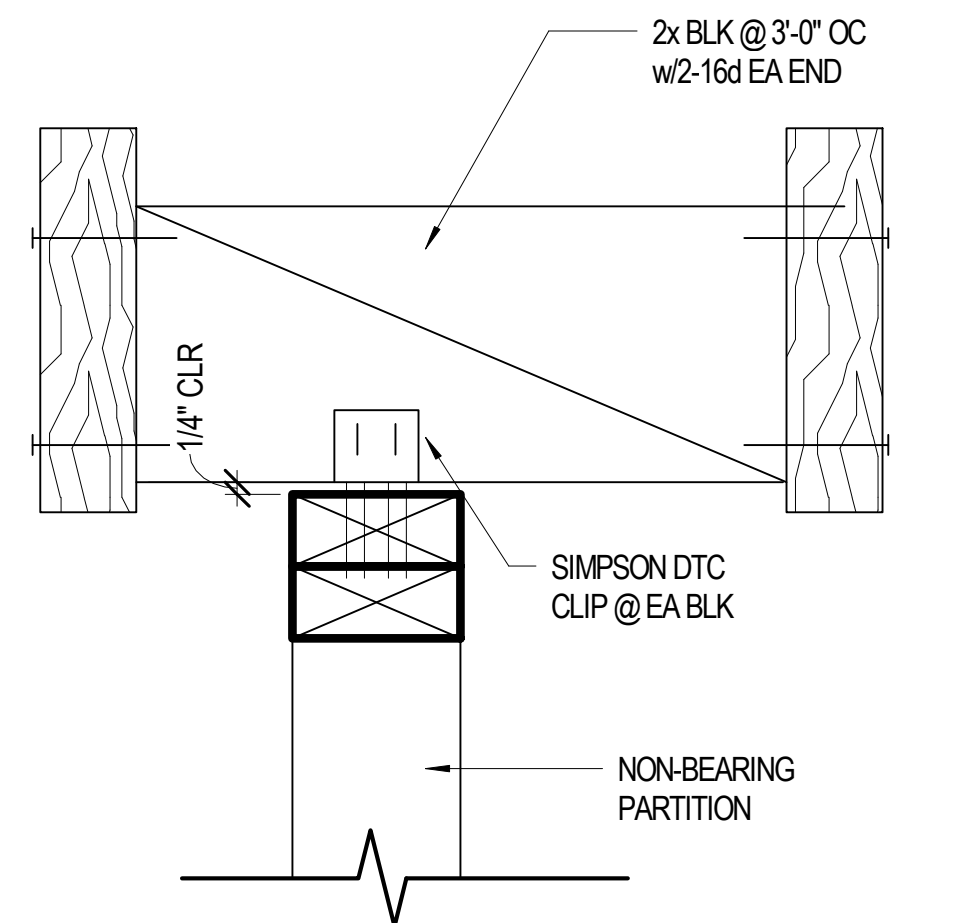

E

D

C

B

A

1/20/2019 4:37:18 PM

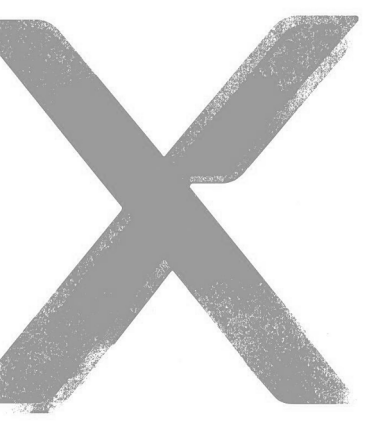

ARCH | NEXUS

Architectural NEXUS, Inc.  
930 R Street  
Sacramento, California 95811  
T 916.443.5911  
http://www.archnexus.com

Original drawings remain the property of the Architect and as such the Architect retains total ownership and control. The design represented by these drawings is sold to the client for a one time use, unless otherwise agreed upon in writing by the Architect. © Architectural Nexus, Inc. 2014

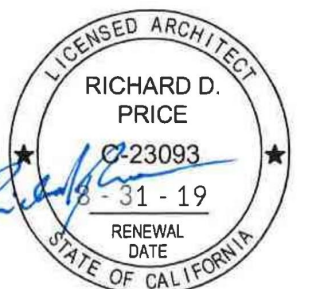

COUNTY OF EL DORADO  
**HHSA TENANT IMPROVEMENT**  
3368 SANDY WAY  
SOUTH LAKE TAHOE, CA 96150

# Date Revision

CONSTRUCTION DOCUMENTS

NEXUS PROJ. #: 18117  
CHECKED BY: RP  
DRAWN BY: MR  
DATE: 01.02.2019

ACCESSIBILITY COMPLIANCE

G701  
18-1912 Revised B 79 of 606  
BOS Rcvd 1-24-19

- NOTES:
1. MOUNT SIGN ON DOOR, LOCATE ABOVE AND WITHIN 12" OF THE DOOR EXIT HARDWARE.
  2. SIGNS SHALL BE LAMINATED ACRYLIC WITH RADIUS CORNERS.
  3. CHARACTERS & BACKGROUND TO HAVE A NON-GLARE FINISH.
  4. CHARACTERS SHALL CONTRAST WITH THEIR BACKGROUND.

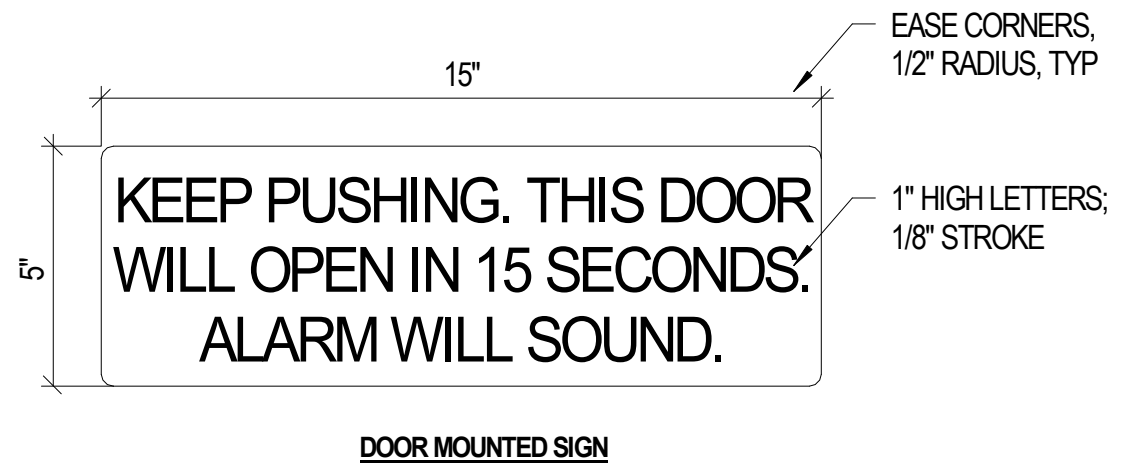

DOOR MOUNTED SIGN

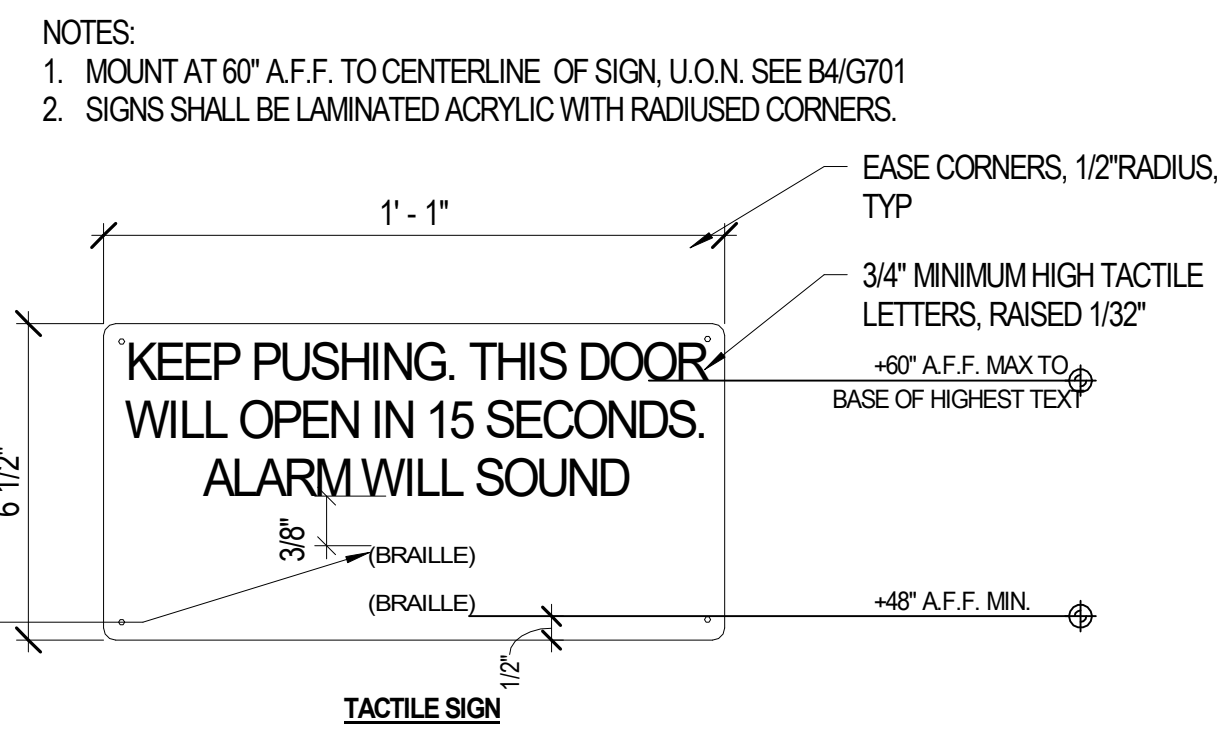

E3 SIGN - DELAYED EGRESS  
G701 3" = 1'-0"

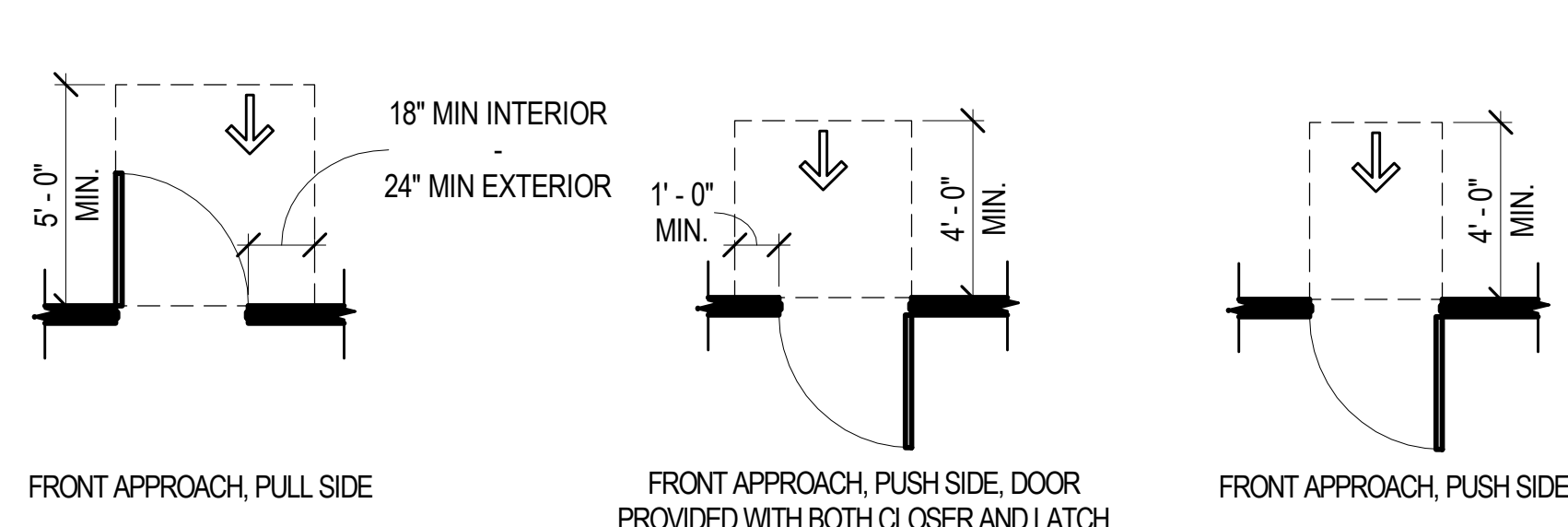

E2 ADA DOOR CLEARANCES  
G701 1/4" = 1'-0"

- TYPICAL NOTES:
1. MOUNT AT 60" A.F.F. TO CENTERLINE OF SIGN, U.O.N. SEE B4/G701
  2. SIGNS SHALL BE LAMINATED ACRYLIC WITH RADIUS CORNERS.
  3. ATTACH EXTERIOR SIGNS WITH (4) TAMPER PROOF FASTENERS AND ADHESIVE AT EXTERIOR CONDITION, UNLESS MOUNTED ON GLASS.
  4. ADHESIVE FOR MOUNTING ON GLASS SHALL BE TRANSPARENT AND COVER THE ENTIRE BACK SIDE OF SIGN. VISUAL INSTALLATION IS SUBJECT TO INSPECTION AND ACCEPTANCE FROM ARCHITECT.

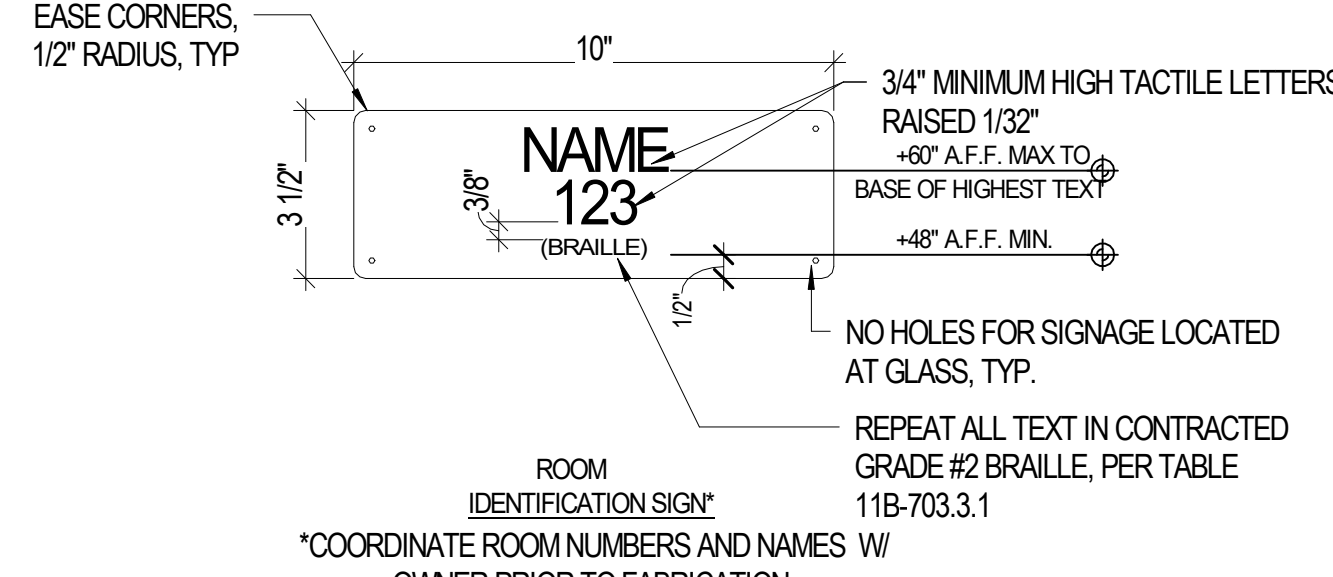

D2 SIGN ROOM IDENTIFICATION  
G701 3" = 1'-0"

GENERAL NOTE - ACCESSIBILITY

- A. THESE DETAILS ARE SHOWN FOR MINIMUM ACCESSIBILITY REQUIREMENTS. SEE PROJECT SPECIFIC DETAILS FOR ADDITIONAL INFORMATION. VERIFY WITH ARCHITECT ANY DIFFERENCES BEFORE PROCEEDING WITH CONSTRUCTION.

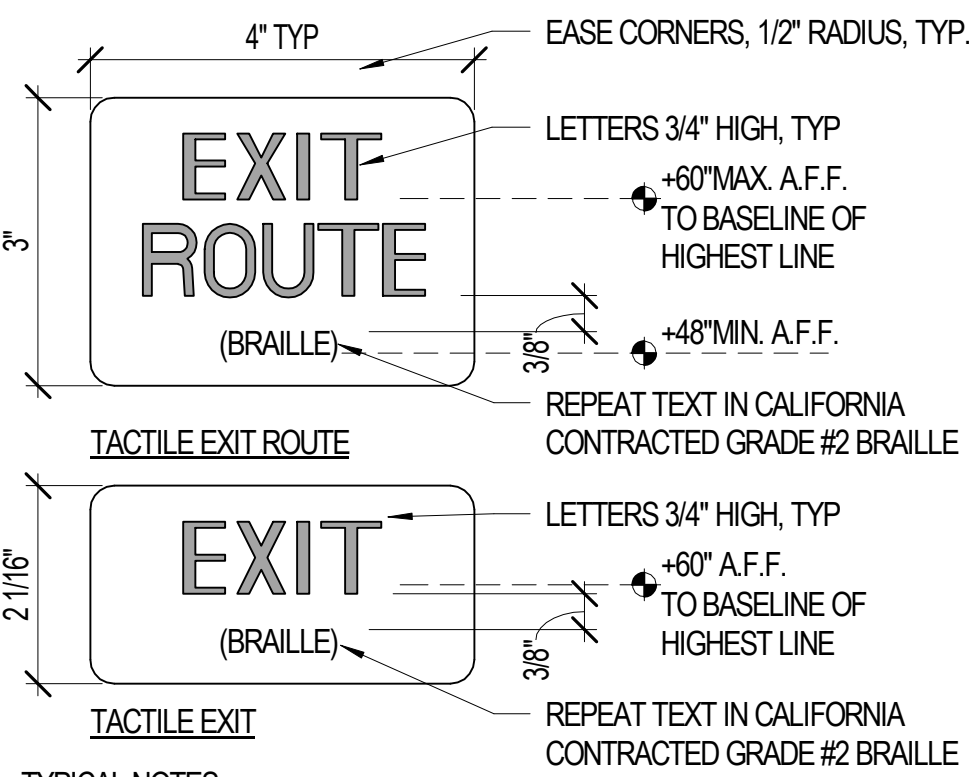

- TYPICAL NOTES:
1. SIGNS SHALL BE OF LAMINATED ACRYLIC WITH TACTILE TEXT AND BRAILLE, RAISED 1/32". CORNERS SHALL BE ROUNDED.
  2. ATTACH EXTERIOR SIGN WITH (4) TAMPER PROOF FASTENERS AND ADHESIVE AT EXTERIOR CONDITION, UNLESS MOUNTED ON GLASS.
  3. ADHESIVE FOR MOUNTING ON GLASS SHALL BE TRANSPARENT AND COVER THE ENTIRE BACK SIDE OF SIGN. VISUAL INSTALLATION IS SUBJECT TO INSPECTION AND ACCEPTANCE FROM ARCHITECT.

D1 TACTILE EXIT SIGNS  
G701 6" = 1'-0"

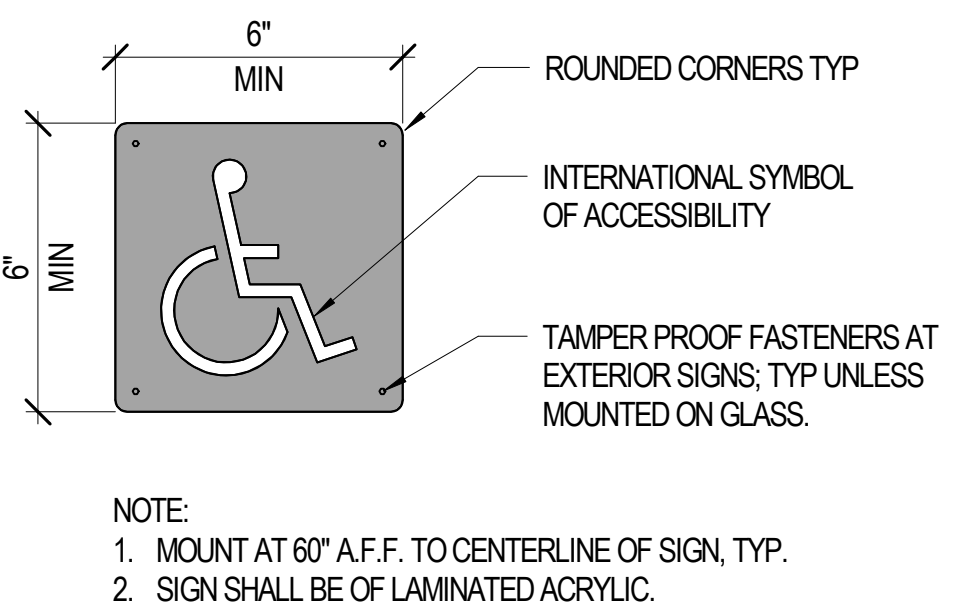

- NOTE:
1. MOUNT AT 60" A.F.F. TO CENTERLINE OF SIGN, TYP.
  2. SIGN SHALL BE OF LAMINATED ACRYLIC.

C1 SYMBOL OF ACC. SIGN  
G701 3" = 1'-0"

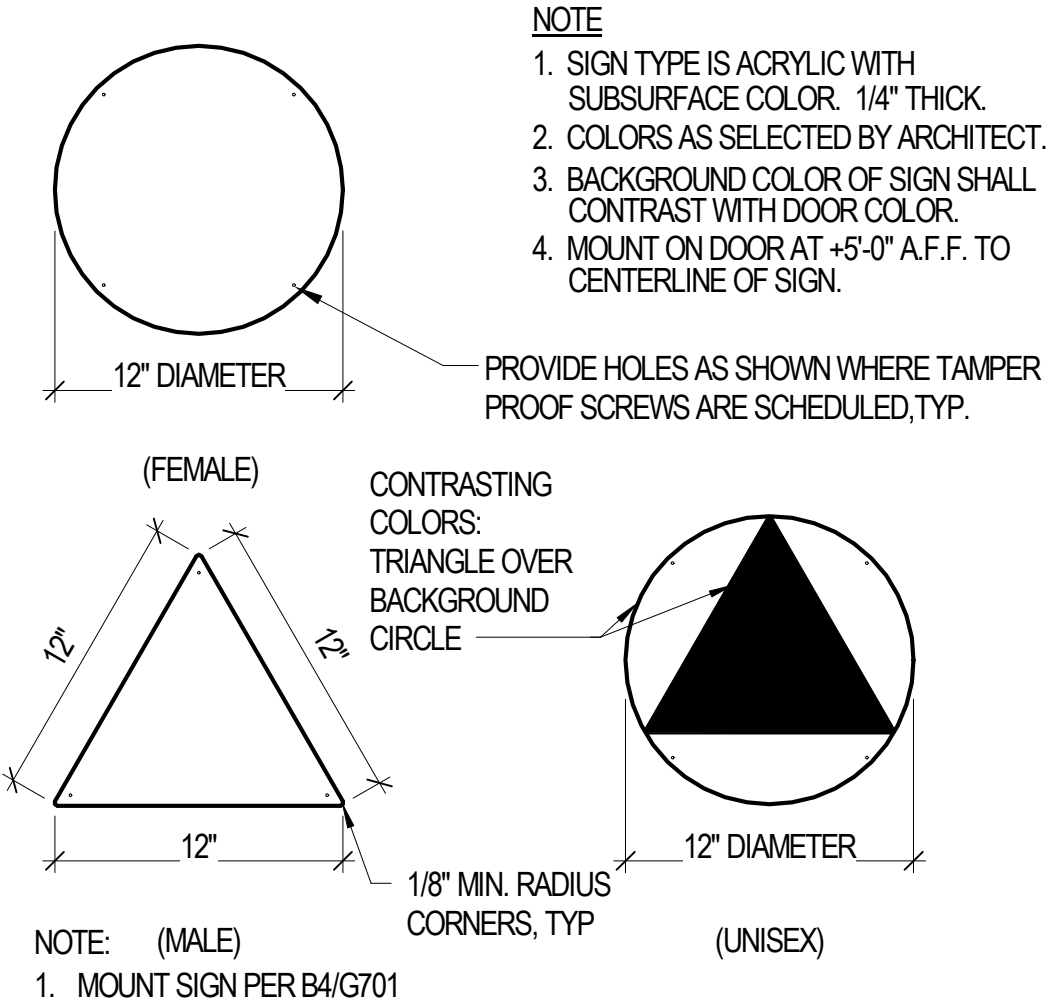

B1 TOILET ROOM DOOR SIGNS  
G701 1 1/2" = 1'-0"

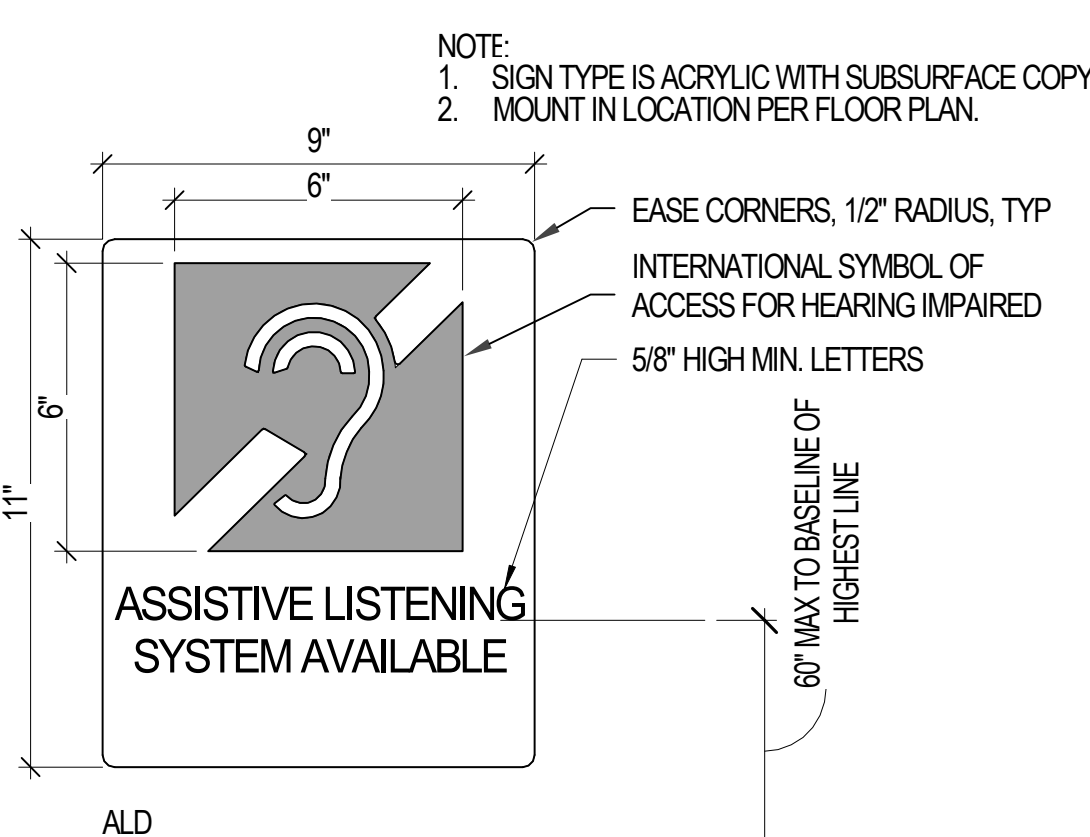

A ASSISTED LISTENING SIGN  
G701 3" = 1'-0"

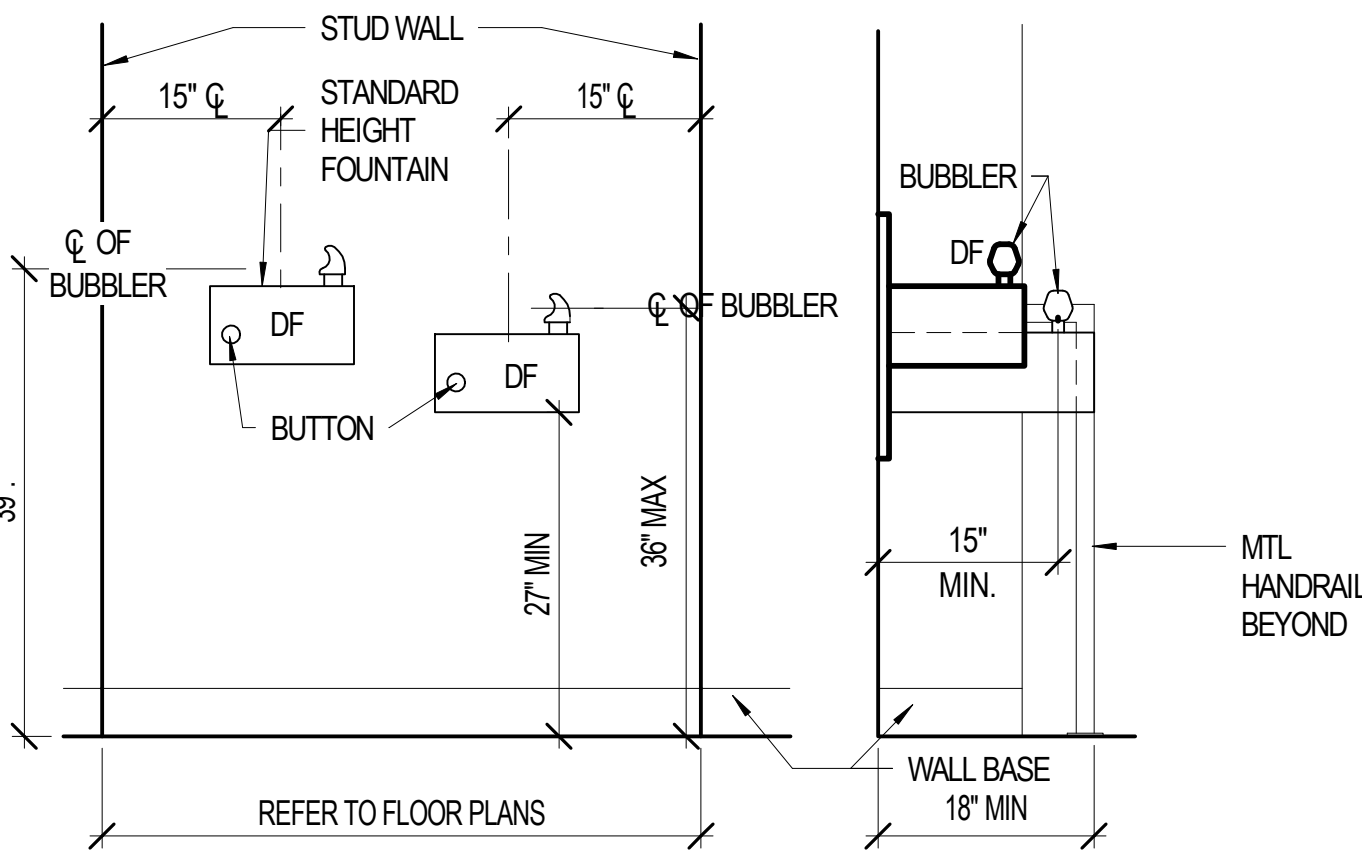

C3 DRINKING FOUNTAIN HI-LO  
G701 3/4" = 1'-0"

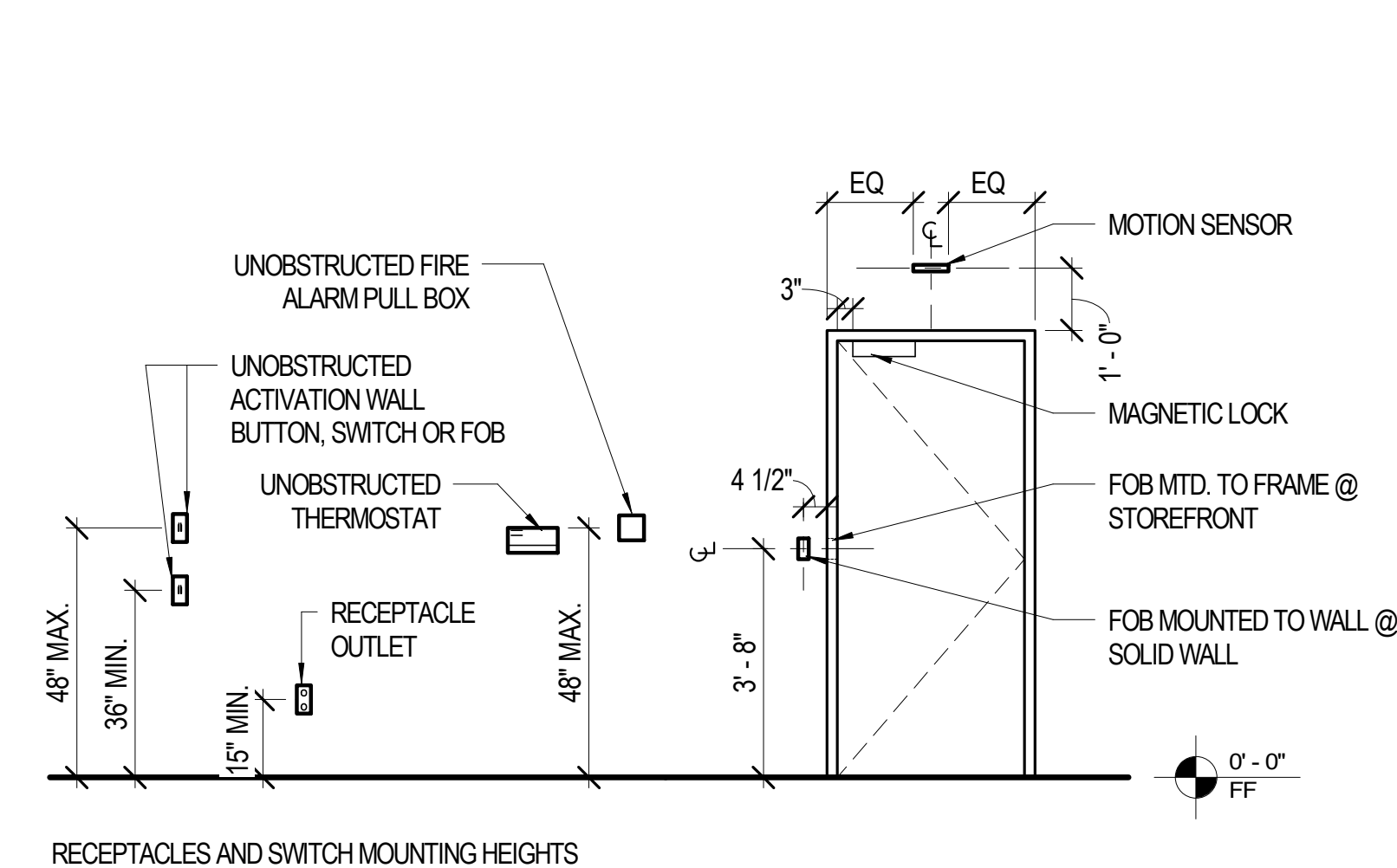

B3 MISC. MOUNTING HEIGHTS  
G701 3/8" = 1'-0"

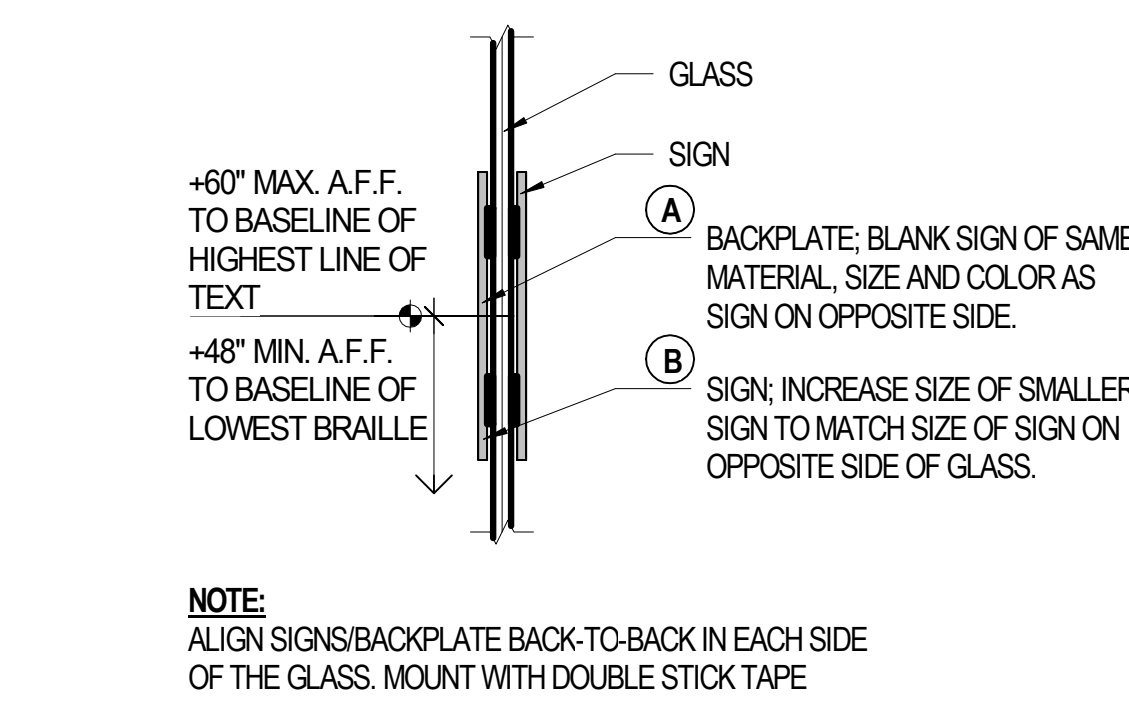

D3 SIGN MOUNTED ON GLASS  
G701 6" = 1'-0"

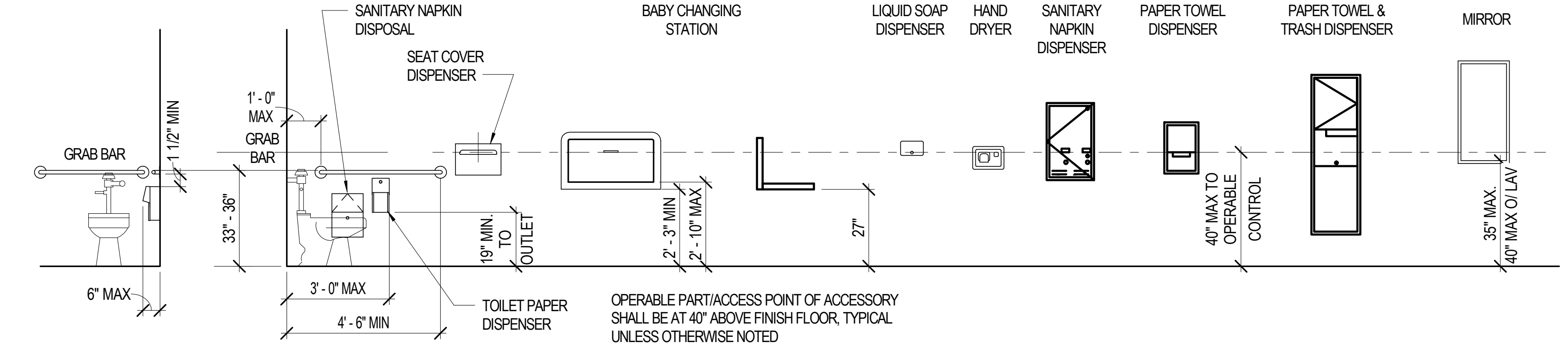

C4 RESTROOM MOUNTING HEIGHTS  
G701 3/8" = 1'-0"

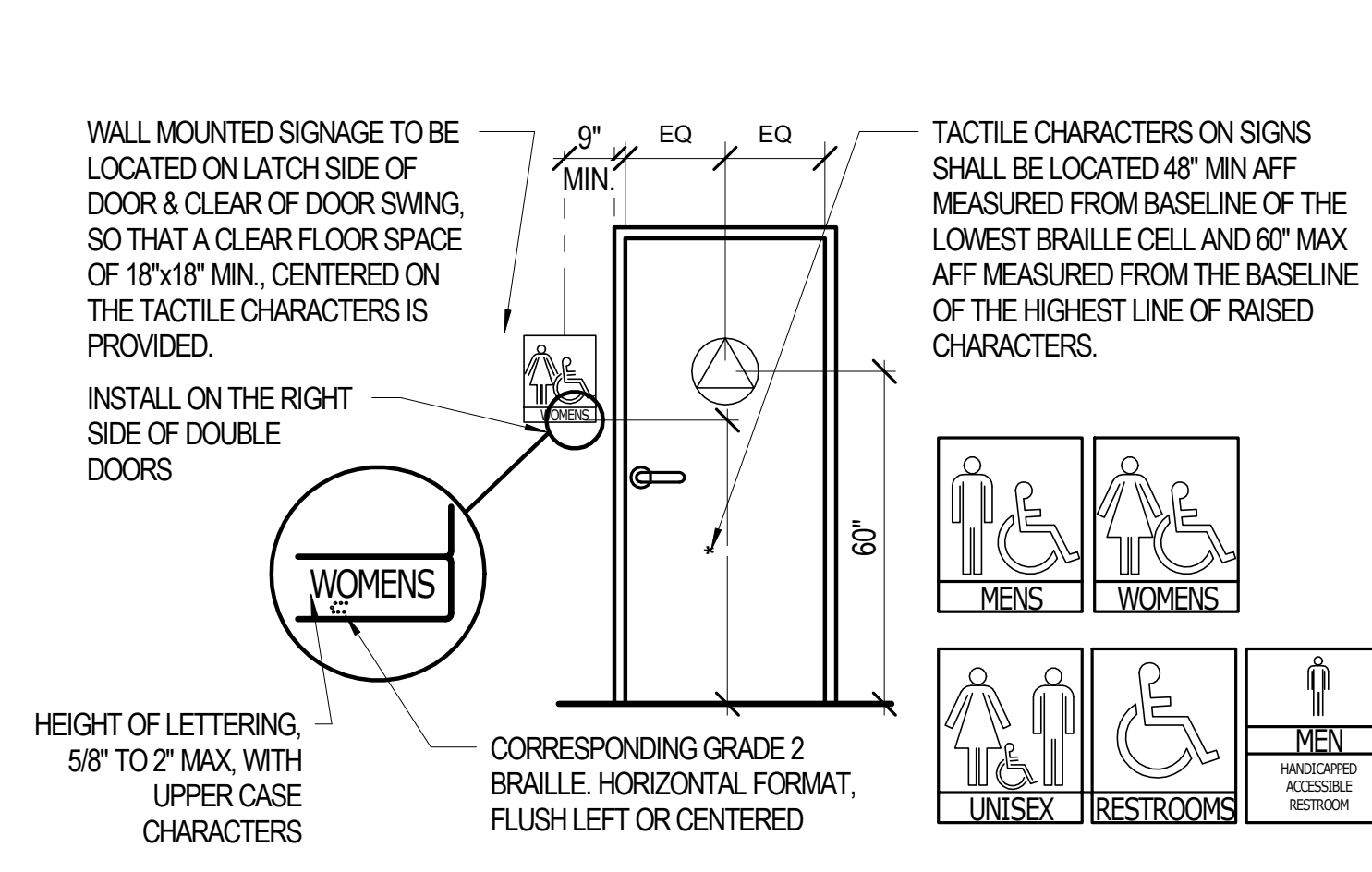

B4 SIGNAGE MOUNTING  
G701 3/8" = 1'-0"

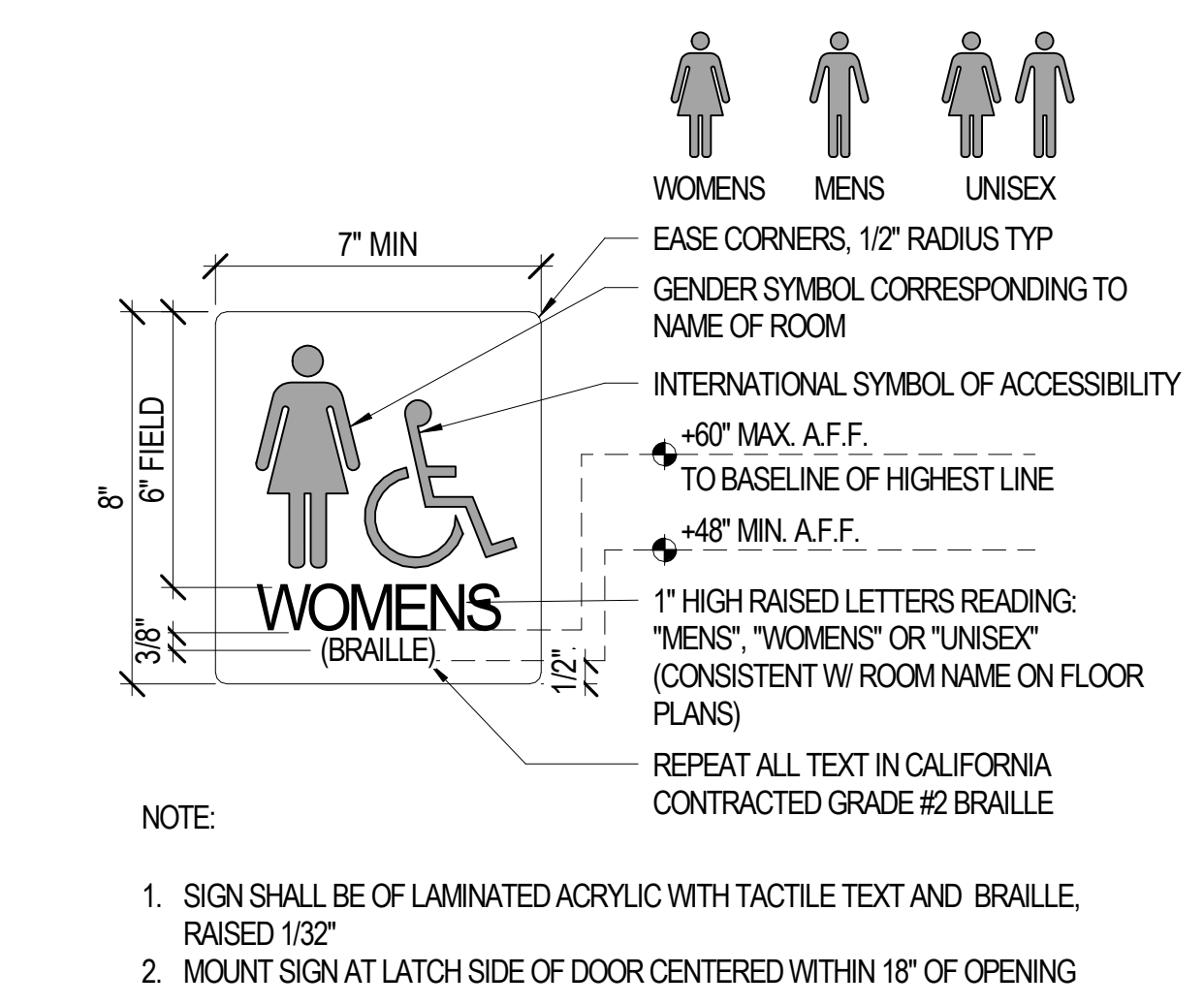

B6 TOILET ROOM IDENTIFICATION SIGN  
G701 3" = 1'-0"

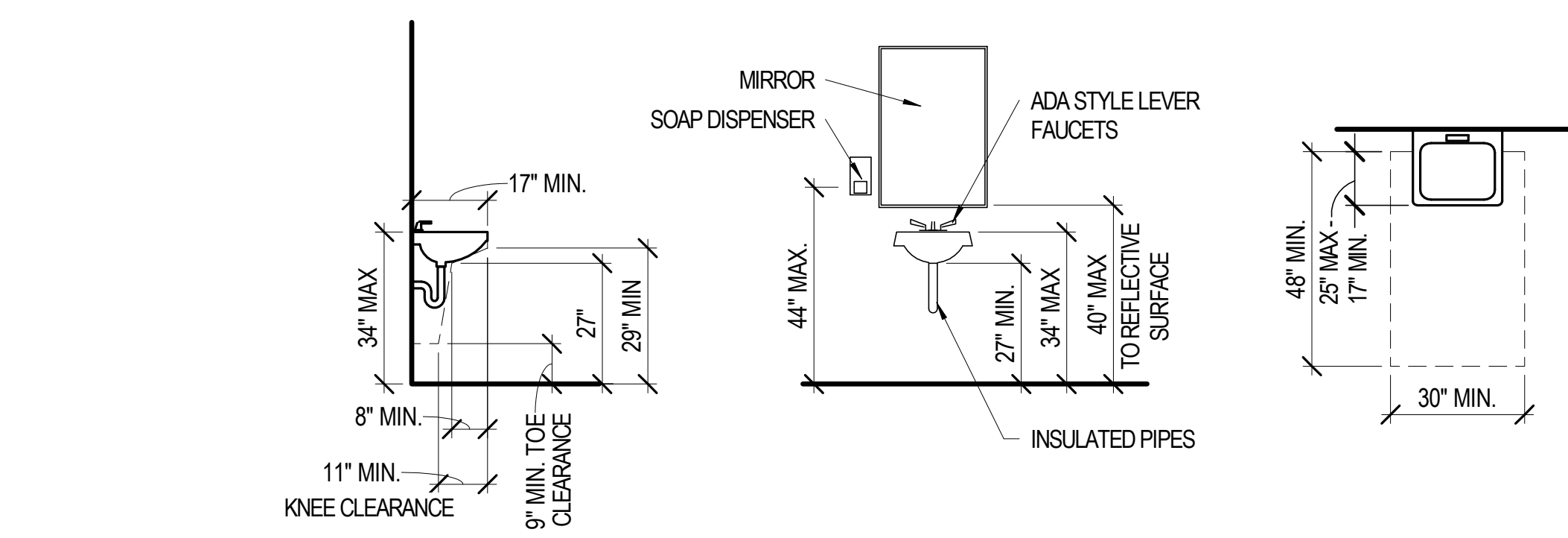

A1 URINAL MOUNTING HEIGHT  
G701 3/8" = 1'-0"

A2 ACCESSIBLE SINK DETAIL  
G701 3/8" = 1'-0"

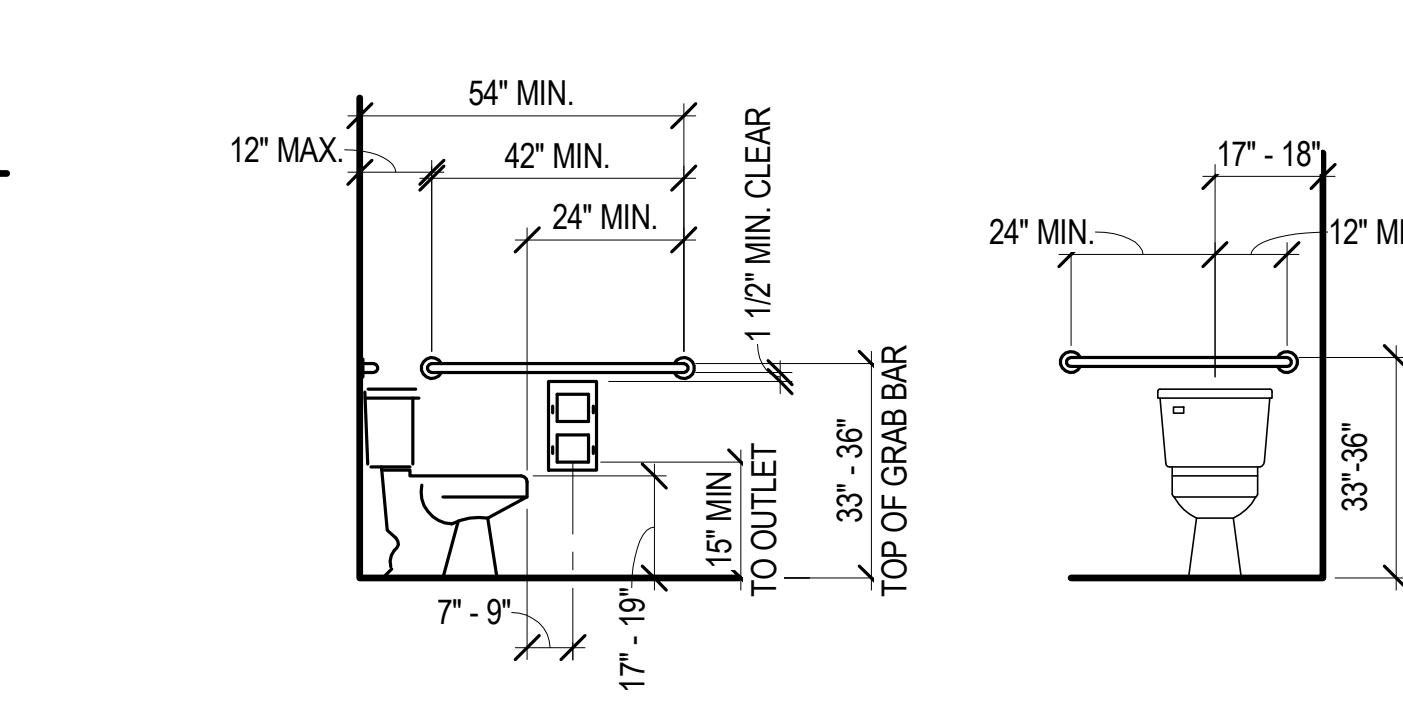

A3 ACCESSIBLE FLOOR MOUNTED TOILET DETAIL  
G701 3/8" = 1'-0"

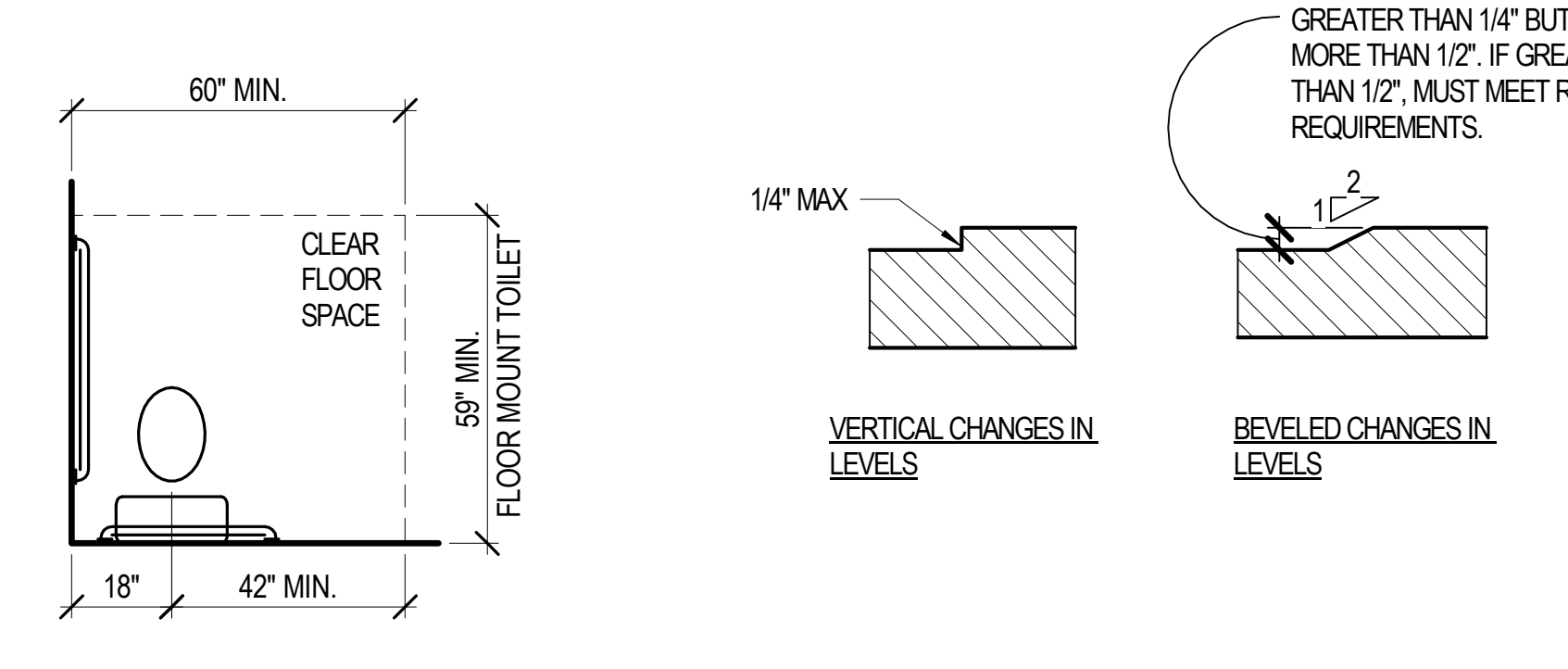

B5 CHANGE IN LEVELS  
G701 6" = 1'-0"

10/20/19 4:37:22 PM

**GENERAL NOTE - SITE PLAN**

A. NOTE: ALL SITE WORK IS NIC

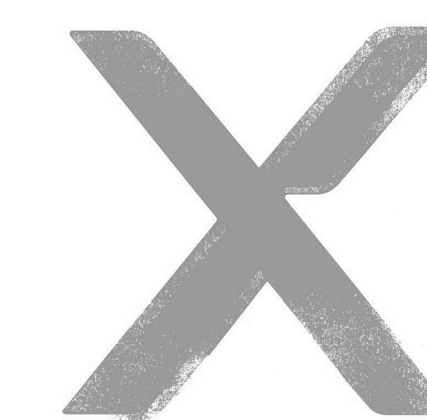

ARCH | NEXUS

Architectural NEXUS, Inc.  
930 R Street  
Sacramento, California 95811  
T 916.443.5911  
http://www.archnexus.com

Original drawings remain the property of the Architect and as such the Architect retains total ownership and control. The design represented by these drawings is sold to the client for a one time use, unless otherwise agreed upon in writing by the Architect.  
© Architectural Nexus, Inc. 2014



COUNTY OF EL DORADO  
**HHSA TENANT IMPROVEMENT**  
3368 SANDY WAY  
SOUTH LAKE TAHOE, CA 96150

#	Date	Revision

**CONSTRUCTION DOCUMENTS**

NEXUS PROJ. #: 18117  
CHECKED BY: RP  
DRAWN BY: MR  
DATE: 01.02.2019

**ARCHITECTURAL SITE PLAN**

**AS101**  
18-1912 Revised B 80 of 606  
BOS Rcvd 1-24-19

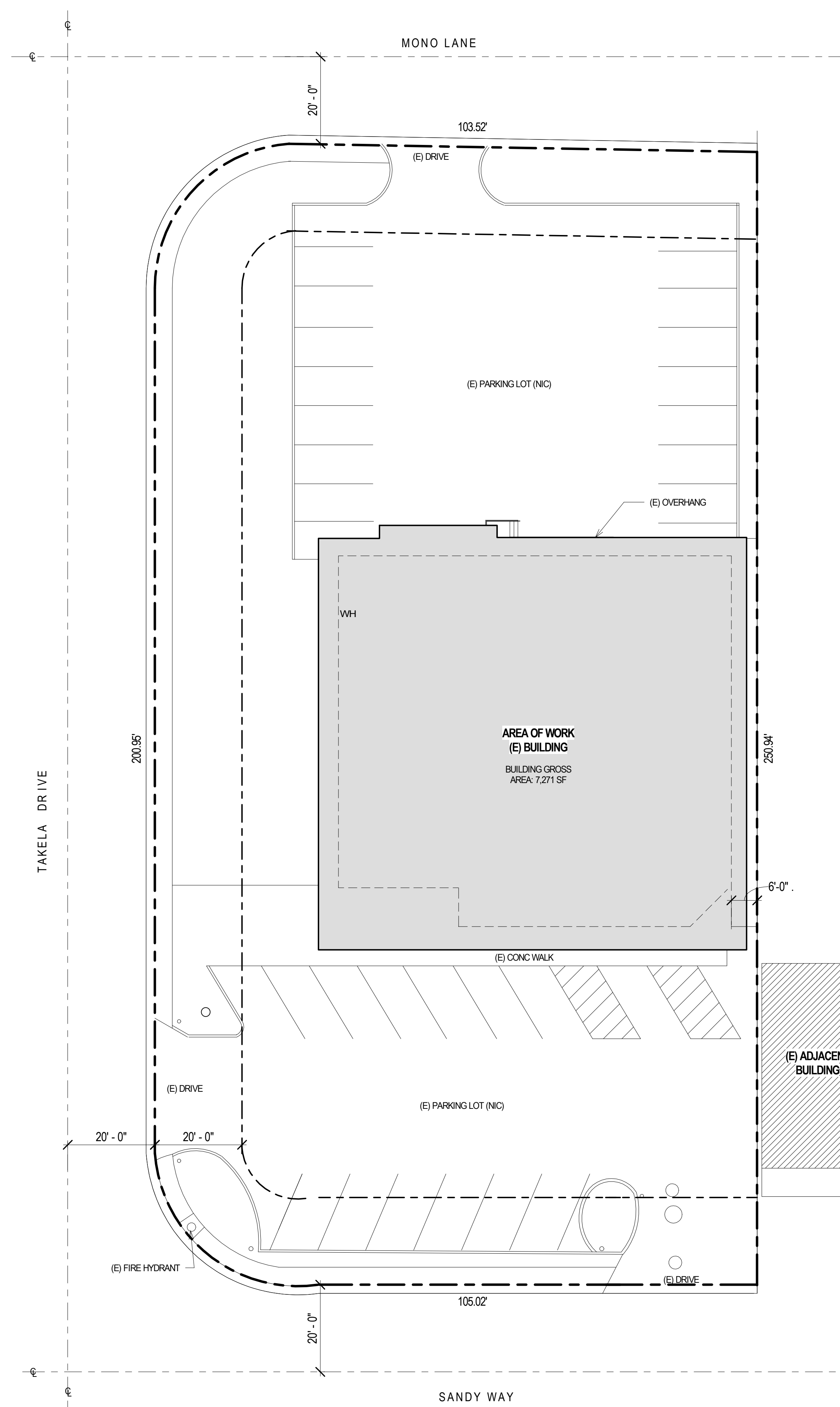

**A1 LEVEL 01 - ARCHITECTURAL SITE PLAN**  
AS101 1/16" = 1'-0"

((E) SITE PLAN SHOWN FOR REFERENCE ONLY)

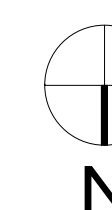



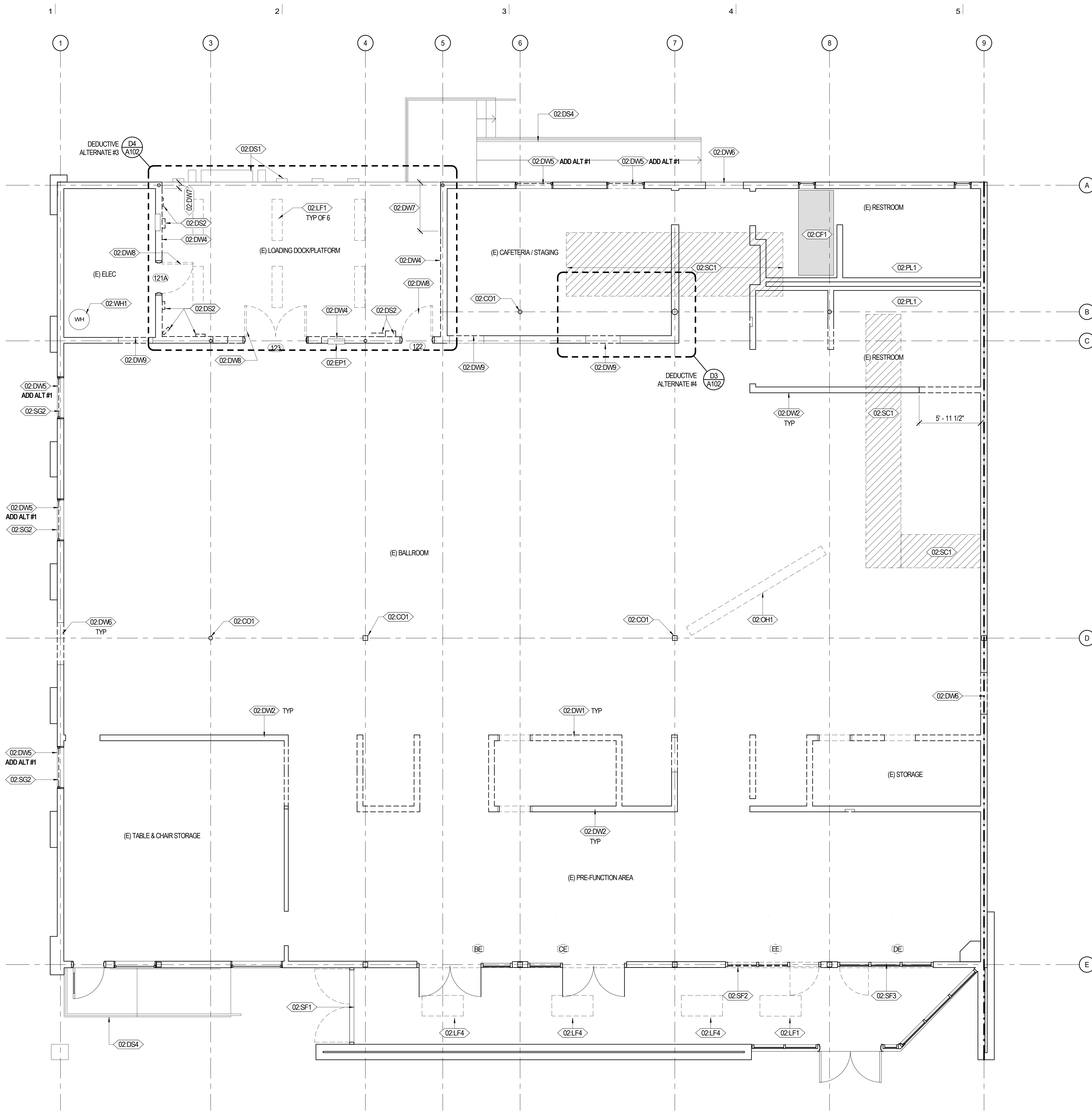

**A1 LEVEL 01 - DEMOLITION PLAN**  
AD101 1/4" = 1'-0"

**GENERAL NOTE - DEMOLITION PLAN**

- A. PROTECT WALLS, CEILINGS, FLOORS AND OTHER EXISTING FINISH WORK THAT ARE TO REMAIN OR THAT ARE EXPOSED DURING SELECTIVE DEMOLITION OPERATIONS
- B. PATCH AND REPAIR DAMAGE IN WALLS, CEILINGS, AND FLOORS RESULTING FROM DEMOLITION OF EXISTING ITEMS OR CONSTRUCTION OF NEW ITEMS AND/OR REPLACE WITH NEW TO MATCH EXISTING. CLEAN AND PREPARE TO RECEIVE NEW FINISH. ALL EXISTING DAMAGE TO BE REPAIRED FOR NEW FINISH. PROVIDE FLOOR PREP AS NEEDED THROUGHOUT. REMOVE ALL EXCESS MORTAR, GRIND, INFILL AND FLOAT AS NEEDED FOR NEW FLOOR FINISH. THIS INCLUDES ALL EXISTING FLOOR CONDITIONS AND CONCRETE POUR-BACK.
- C. TRANSPORT DEMOLISHED MATERIALS OFF OWNERS PROPERTY AND LEGALLY DISPOSE OF DEBRIS.
- D. FIELD VERIFY EXISTING CONDITIONS AND THEIR COMPATIBILITY WITH NEW CONSTRUCTION PRIOR TO THE COMMENCEMENT OF WORK. COORDINATE DISCREPANCIES WITH ARCHITECT.
- E. CLEAN ADJACENT AREAS OF DUST, DIRT, AND DEBRIS CAUSE BY SELECTIVE DEMOLITION OPERATIONS. RETURN ADJACENT AREAS TO CONDITION EXISTING BEFORE SELECTIVE DEMOLITION OPERATIONS BEGAN.
- F. SEE MECHANICAL AND ELECTRICAL DRAWINGS FOR ADDITIONAL INFORMATION. COORDINATE DISCREPANCIES WITH ARCHITECT PRIOR TO PROCEEDING WITH WORK.
- G. RETURN ALL REMOVED DOORS & HARDWARE TO OWNER.
- H. SALVAGE & REUSE WOOD STUDS WHERE POSSIBLE.
- I. (E) CONDUITS, BOXES, HANGERS AND CONDUCTORS FOR EXTERIOR LIGHTS ARE TO BE TEMPORARILY REMOVED FROM WALL & SUSPENDED TO ALLOW FOR DRYWALL FINISH AT ALL OPEN AREA CONDITIONS WHERE SCRM SHEET WILL BE APPLIED. SEE SHEET A 151 FOR SCRM LOCATION. REINSTALL AFTER DRYWALL IS INSTALLED. ANY EXPOSED CONDUITS/BOXES IN OPEN CEILING AREAS TO BE PAINTED TO MATCH ADJACENT SURFACE.

**WALL TYPE LEGEND - DEMO**

- EXISTING WOOD STUD WALL TO REMAIN
- EXISTING 1 HOUR WALL TO REMAIN
- WALL TO BE REMOVED

KEYNOTE LEGEND	
Key Value	Keynote Text
02.CF1	PREP FLOOR AS REQUIRED FOR NEW FINISH
02.CO1	(E) COLUMN TO REMAIN, PROTECT IN PLACE
02.DS1	EXISTING WALL MOUNTED EQUIPMENT AT LOADING DOCK TO REMAIN
02.DS2	REMOVE EXISTING EQUIPMENT AT LOADING DOCK (SHOWN DASHED)
02.DS4	(E) RAMP, STAIR & HANDRAIL TO REMAIN - NIC
02.DW1	DEMOLISH PORTION OF EXISTING WALL (SHOWN DASHED). SALVAGE & REUSE STUDS WHERE POSSIBLE
02.DW2	ASSUME ALL (E) INTERIOR WALLS TO REMAIN ARE BARE STUDS, UNO. EXISTING WALLS TO REMAIN TO RECEIVE 5/8" GYP BOTH SIDES & INSULATION
02.DW4	REMOVE (E) EXTERIOR WALL FINISH AND SALVAGE FOR REINSTALLATION AT EXTERIOR INFILL LOCATIONS
02.DW5	ADD ALT#1: REMOVE (E) GLAZING & FRAME. PREP OPENINGS FOR (N) FRAME & GLAZING
02.DW6	REMOVE (E) TEMPORARY COVERS AT OPENINGS FOR INFILL
02.DW7	PORTION OF (E) SIDING TO REMAIN. COORDINATE WITH (N) FLOOR PLAN
02.DW8	REMOVE (E) DOOR & FRAME
02.DW9	REMOVE PORTION OF (E) WALL FOR NEW DOOR OPENING
02.EP1	(E) ELECTRICAL PANEL TO REMAIN
02.LF1	(E) LIGHT FIXTURE TO BE REMOVED. PATCH FINISHES AS REQUIRED
02.LF4	REMOVE (E) 2X4 LIGHT FIXTURE PREP OPENING FOR NEW 2X4 LIGHT FIXTURE.
02.OH1	REMOVE (E) OVERHEAD COILING GRILLE & SUPPORTS. PATCH FLOOR AS REQUIRED. VERIFY LOCATION IN FIELD
02.PL1	(E) DRAIN & WASTE LINES TO REMAIN
02.SC1	SAWCUT & REMOVE PORTION OF (E) SLAB AS REQUIRED FOR NEW WORK. SEE PLUMBING DRAWINGS FOR MORE INFORMATION
02.SF1	REMOVE (E) DOORS, (E) FRAMES AND GLAZING TO REMAIN. PROTECT. PREP OPENINGS FOR NEW GLAZING
02.SF2	REMOVE & SALVAGE (E) STOREFRONT SYSTEM. PREP FOR REINSTALLATION. SEE NEW FLOOR PLAN FOR MORE INFORMATION
02.SF3	(E) STOREFRONT TO REMAIN. PREP FOR MODIFICATION OF DOOR LOCATION. SEE NEW FLOOR PLAN FOR NEW DOOR LOCATION
02.SG2	REMOVE (E) MTL SECURITY GRILLES
02.WH1	REMOVE & RELOCATE (E) WATER HEATER. SEE NEW FLOOR PLAN FOR LOCATION

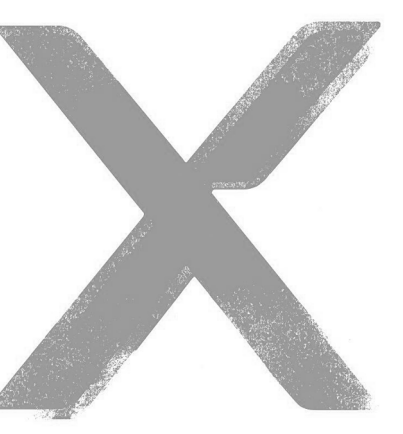

ARCH | NEXUS  
Architectural NEXUS, Inc.  
930 R Street  
Sacramento, California 95811  
T 916.443.5911  
http://www.archnexus.com

Original drawings remain the property of the Architect and as such the Architect retains total ownership and control. The design represented by these drawings is sold to the client for a one time use, unless otherwise agreed upon in writing by the Architect.  
© Architectural Nexus, Inc. 2014



COUNTY OF EL DORADO  
**HHSA TENANT IMPROVEMENT**  
3368 SANDY WAY  
SOUTH LAKE TAHOE, CA 96150

#	Date	Revision

**CONSTRUCTION DOCUMENTS**

NEXUS PROJ. #: 18117  
CHECKED BY: RD  
DRAWN BY: CJ/MR  
DATE: 01.02.2019

**DEMOLITION PLAN**

**AD101**  
18-1912 Revised B 81 of 606  
BOS Revd 1-24-19

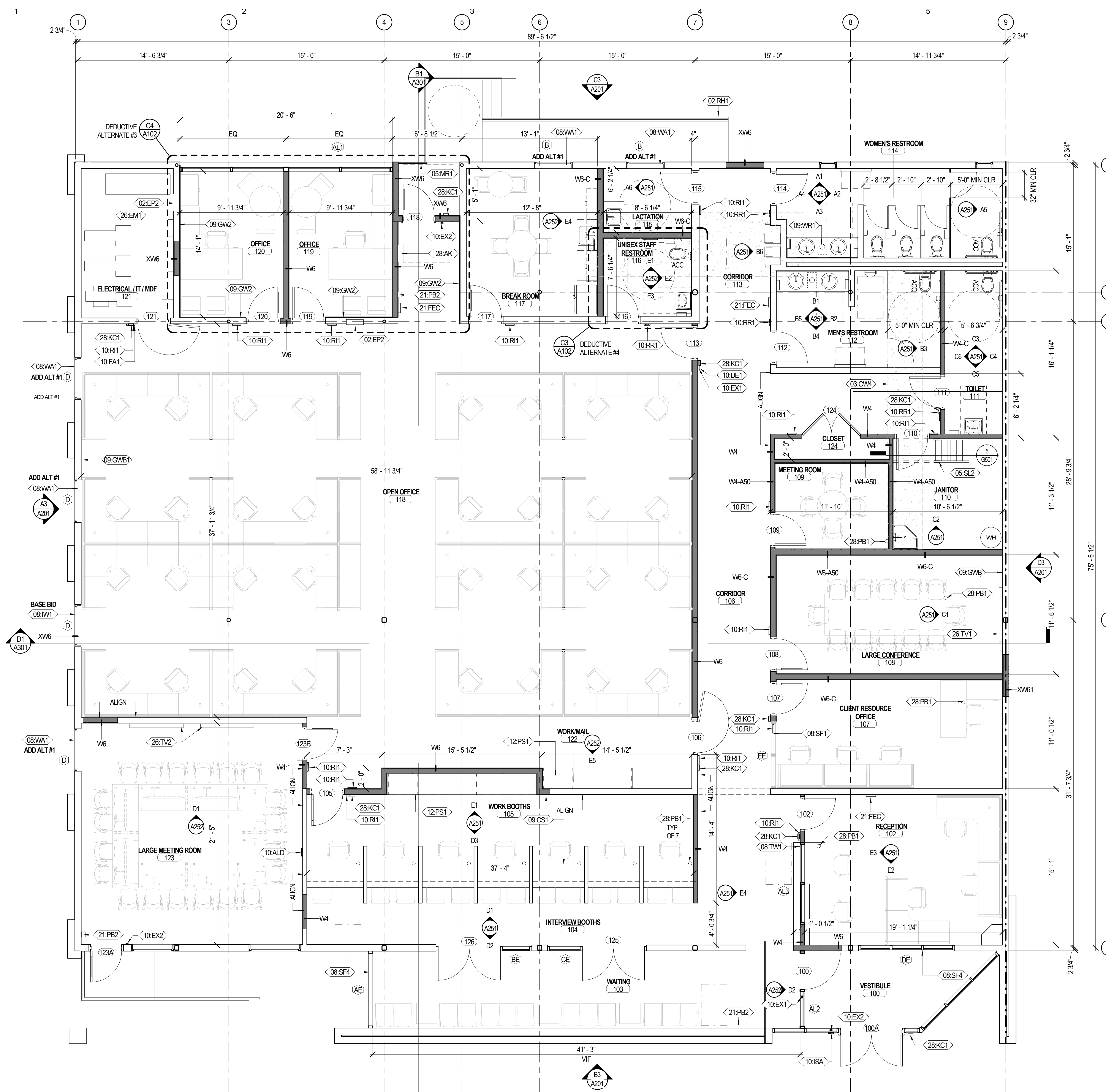

**GENERAL NOTE - FLOOR PLAN**

- A. PLAN WALL DIMENSIONS ARE TO GRID LINE OR FACE OF WALL STRUCTURE. "CLEAR" DIMENSIONS ARE TO FACE OF WALL FINISH.
- B. FIELD VERIFY ALL EXISTING CONDITIONS AND THEIR COMPATIBILITY WITH NEW CONSTRUCTION PRIOR TO THE COMMENCEMENT OF WORK. COORDINATE DISCREPANCIES WITH ARCHITECT.
- C. DO NOT SCALE DRAWINGS.
- D. SEE PLUMBING AND ELECTRICAL DRAWINGS FOR MORE INFORMATION.
- E. SEE G SERIES SHEETS FOR WALL TYPES AND TYPICAL ACCESSIBILITY CLEARANCE AND COMPLIANCE REQUIREMENTS.
- F. PROVIDE BACKING BEHIND ALL SURFACE MOUNTED EQUIPMENT AND/OR FIXTURES PER DETAIL 26/A701
- G. SHIM & SHAVE (E) WOOD FRAMING FOR INSTALLATION OF NEW DRYWALL.
- H. PAINT ALL EXPOSED CONDUIT, BOXES AND RELATED ITEMS IN OPEN CEILING AREA.
- I. SEE TYPICAL NEW FRAMED WALL OPENING & TYPICAL INFILL FRAMING ON SHEET A501.

**WALL TYPE LEGEND**

- EXISTING WOOD STUD WALL TO REMAIN
- EXISTING 1 HOUR WALL TO REMAIN
- WALL TO BE REMOVED
- NEW OR INFILL WOOD FRAMING
- NEW 1 HOUR WALL

**KEYNOTE LEGEND**

Key Value	Keynote Text
02:EP2	(E) ELECTRICAL PANEL TO REMAIN
02:RH1	(E) RAMP & RAILING TO REMAIN - NIC. ALL SITE WORK TO BE DONE BY OTHERS
03:CW4	PATCH & REPAIR (E) CONC. SLAB AS REQUIRED FOR NEW WORK. SEE DETAIL D1/A501
05:MR1	1/4" THICK GALVANIZED STL PLATE GUARDRAIL. PAINT TO MATCH BUILDING SIDING; NIC - OFOI
05:SL2	SHIPS LADDER W/ LANDING PLATFORM TO ROOF ACCESS. SEE DETAIL 5/G501
08:IW1	INFILL (E) OPENING & INSTALL NEW WINDOW. INCLUDE IN BASE BID
08:SF1	REINSTALL (E) STOREFRONT
08:SF4	(E) STOREFRONT FRAME & GLAZING. INFILL (E) DOOR OPENING WITH (N) GLAZING & STOPS
08:TW1	TRANSACTION WINDOW
08:WA1	ADD ALT #1 REPLACE EXISTING WINDOWS WITH NEW FRAME AND REFLECTIVE GLAZING.
09:CS1	BUILT-IN COUNTERS W/ MODESTY PANELS BELOW. PARTITION DIVIDERS BETWEEN WITH ACOUSTIC PANELS ON FACES.
09:GW2	PATCH WALL AS REQUIRED. PROVIDE NEW LAYER OF GYP BD.
09:GWB	PATCH (E) GYP BD AS REQUIRED. TYP.
09:GWB1	CONTINUE GYP BD TO STRUCTURE ABOVE AT OPEN CLNG AREA, TYP. REINSTALL & PAINT ALL SURFACE MOUNTED CONDUIT & ACCESSORIES TO MATCH ADJACENT SURFACE. REFURBISHING OF (E) AFFECTED LIGHT FIXTURES, BY OWNER.
09:WR1	PROVIDE 6" DIAMETER OPENING IN COUNTER FOR ACCESS TO WASTE RECEPTACLE BELOW. LOCATE SO THAT WASTE RECEPTACLE WILL NOT OBSTRUCT ACCESSIBLE FLOOR CLEARANCE TO LAVATORY
10:ALD	SIGN, ASSISTED LISTENING DEVICE. SEE DETAIL A/G701
10:DE1	SIGN, DELAYED EGRESS. SEE DETAIL E3/G701
10:EX1	SIGN, EXIT ROUTE. SEE DETAIL D1/G701
10:EX2	SIGN, EXIT. SEE DETAIL D1/G701
10:FA1	SIGN, FIRE ALARM CONTROL PANEL.
10:ISA	SIGN, INTERNATIONAL SYMBOL OF ACCESSIBILITY. SEE DETAIL C1/A701
10:RI1	SIGN, ROOM IDENTIFICATION. SEE DETAIL D2/G701
10:RR1	SIGN, RESTROOM. SEE DETAIL B1, B4, B6/G701
12:PS1	PRINTING STATION
21:FEC	RE-USED SEMI-RECESSED FIRE EXTINGUISHER CABINET. SEE DETAIL C3/A701
21:PB2	FIRE ALARM PULL BOX
26:EM1	ELECTRICAL ROOM EQUIPMENT - SEE ELECTRICAL DRAWINGS FOR LOCATIONS & ADDITIONAL INFO
26:TV1	WALL MOUNT TV SCREEN & CAMERA, OFOI. CONTRACTOR TO PROVIDE BACKING.
26:TV2	MEDIA CENTER W/ WALL MOUNT 65" LCD FLATSCREEN, SMARTBOARD & CAMERA, OFOI. CONTRACTOR TO PROVIDE BACKING.
28:AK	ALARM KEYPAD. SEE ELECTRICAL
28:KC1	KEYCARD ACCESS
28:PB1	PANIC BUTTON



Architectural NEXUS, Inc.  
930 R Street  
Sacramento, California 95811  
T 916.443.5911  
http://www.archnexus.com

Original drawings remain the property of the Architect and as such the Architect retains total ownership and control. The design represented by these drawings is sold to the client for a one time use, unless otherwise agreed upon in writing by the Architect.  
© Architectural Nexus, Inc. 2014



**COUNTY OF EL DORADO**  
**HHSA TENANT IMPROVEMENT**  
3368 SANDY WAY  
SOUTH LAKE TAHOE, CA 96150

#	Date	Revision

**CONSTRUCTION DOCUMENTS**

NEXUS PROJ. #: 18117  
CHECKED BY: RP  
DRAWN BY: CJ/MR  
DATE: 01.02.2019

**FLOOR PLAN**

**A1 LEVEL 01 - OVERALL FLOOR PLAN**  
A101 1/4" = 1'-0"

(FURNITURE, NIC - SHOWN FOR REFERENCE ONLY)

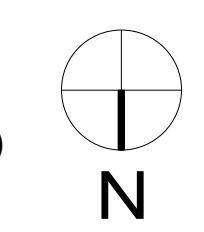

10/20/19 3:36:16 PM

**A101**  
18-1912 Revised B 82 of 606  
BOS Revd 1-24-19

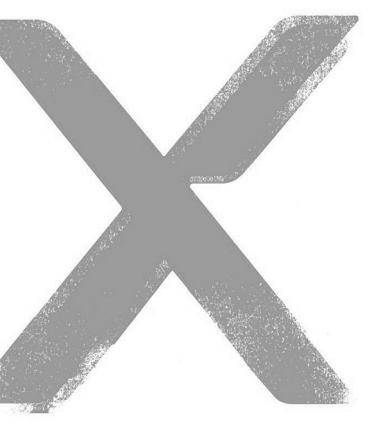

ARCH | NEXUS

Architectural NEXUS, Inc.  
930 R Street  
Sacramento, California 95811  
T 916.443.5911  
http://www.archnexus.com

Original drawings remain the property of the Architect and as such the Architect retains total ownership and control. The design represented by these drawings is sold to the client for a one time use, unless otherwise agreed upon in writing by the Architect.  
© Architectural Nexus, Inc. 2014



COUNTY OF EL DORADO  
**HHSA TENANT IMPROVEMENT**  
3368 SANDY WAY  
SOUTH LAKE TAHOE, CA 96150

KEYNOTE LEGEND	
Key Value	Keynote Text
02.DO1	(E) DOOR TO REMAIN
02.DS1	EXISTING WALL MOUNTED EQUIPMENT AT LOADING DOCK TO REMAIN
02.DW1	DEMOLISH PORTION OF EXISTING WALL (SHOWN DASHED). SALVAGE & REUSE STUDS WHERE POSSIBLE
02.DW8	REMOVE (E) DOOR & FRAME
02.EP1	(E) ELECTRICAL PANEL TO REMAIN
02.EP2	(E) ELECTRICAL PANEL TO REMAIN
02.SC1	SAWCUT & REMOVE PORTION OF (E) SLAB AS REQUIRED FOR NEW WORK. SEE PLUMBING DRAWINGS FOR MORE INFORMATION
05.MG2	(N) GUARDRAIL TO MATCH (E) ADJACENT RAIL, OFOI
06.CJ4	(E) CEILING FRAMING TO REMAIN
08.DO1	REMOVE (E) HARDWARE
08.DO2	EXIT DOOR. REPLACE (E) HARDWARE W/ PANIC HARDWARE. REKEY E/ EF CYLINDER PROVIDE ILLUMINATED EXIT SIGN & TACTILE EXIT SIGN
08.DO3	REKEY DOOR W/ EF CYLINDER
08.SF5	PREP & PATCH WALL AS REQUIRED FOR INSTALLATION OF (N) STOREFRONT SYSTEM
26.LF1	(E) LIGHT FIXTURE TO REMAIN. PAINT ALL EXPOSED SURFACE MOUNTED CONDUIT & ACCESSORIES TO MATCH ADJACENT SURFACE. REFURBISHING OF LIGHT FIXTURE BY OWNER, AS REQUIRED
28.KC1	KEYCARD ACCESS
28.SC1	EXTERIOR, VANDAL PROOF SECURITY CAMERA W/ NIGHT VISION & HEATER, TYP OF 3 OFCI

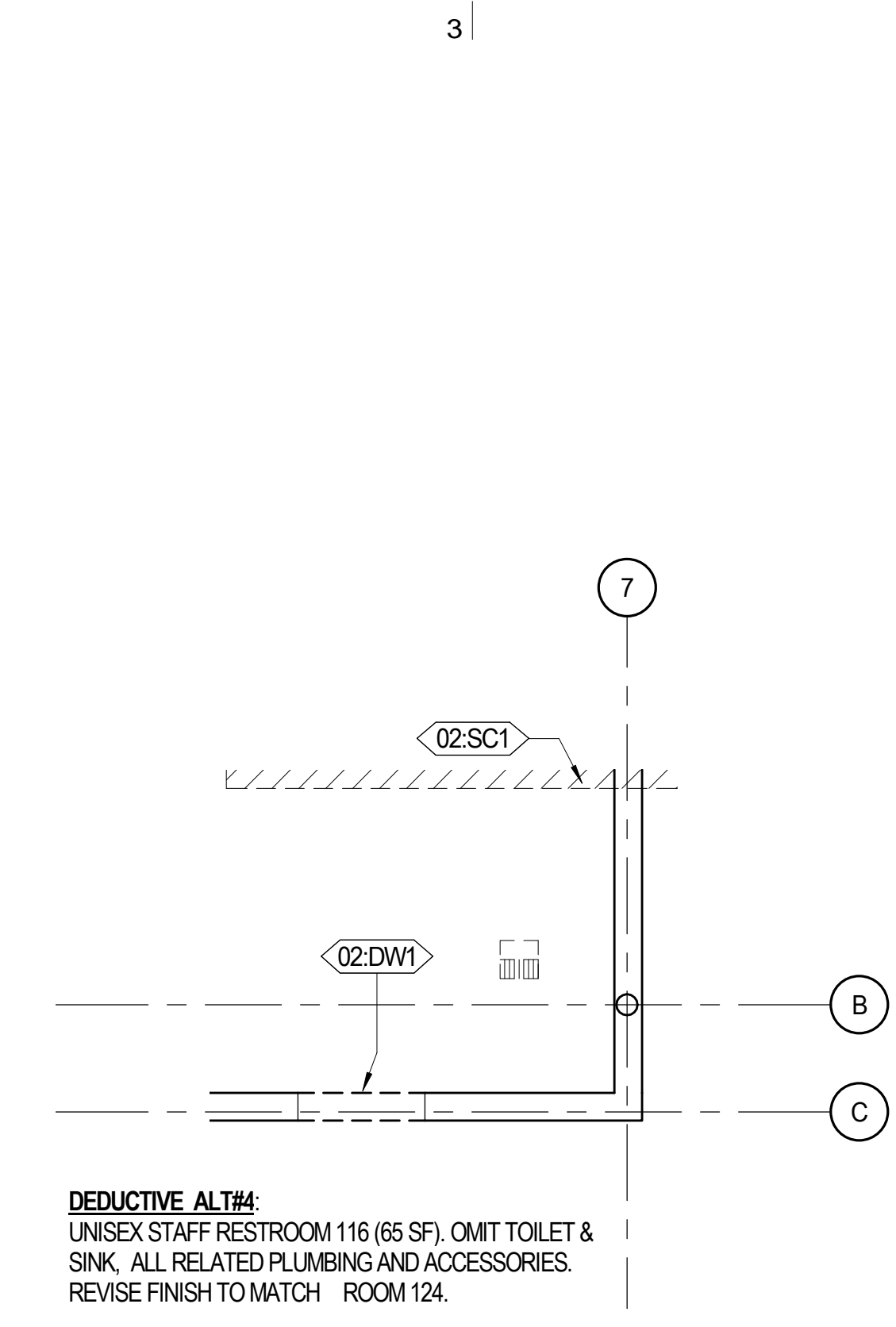

**D3 DEMO PLAN DEDUCTIVE ALTERNATE #4**  
A102 1/4" = 1'-0"

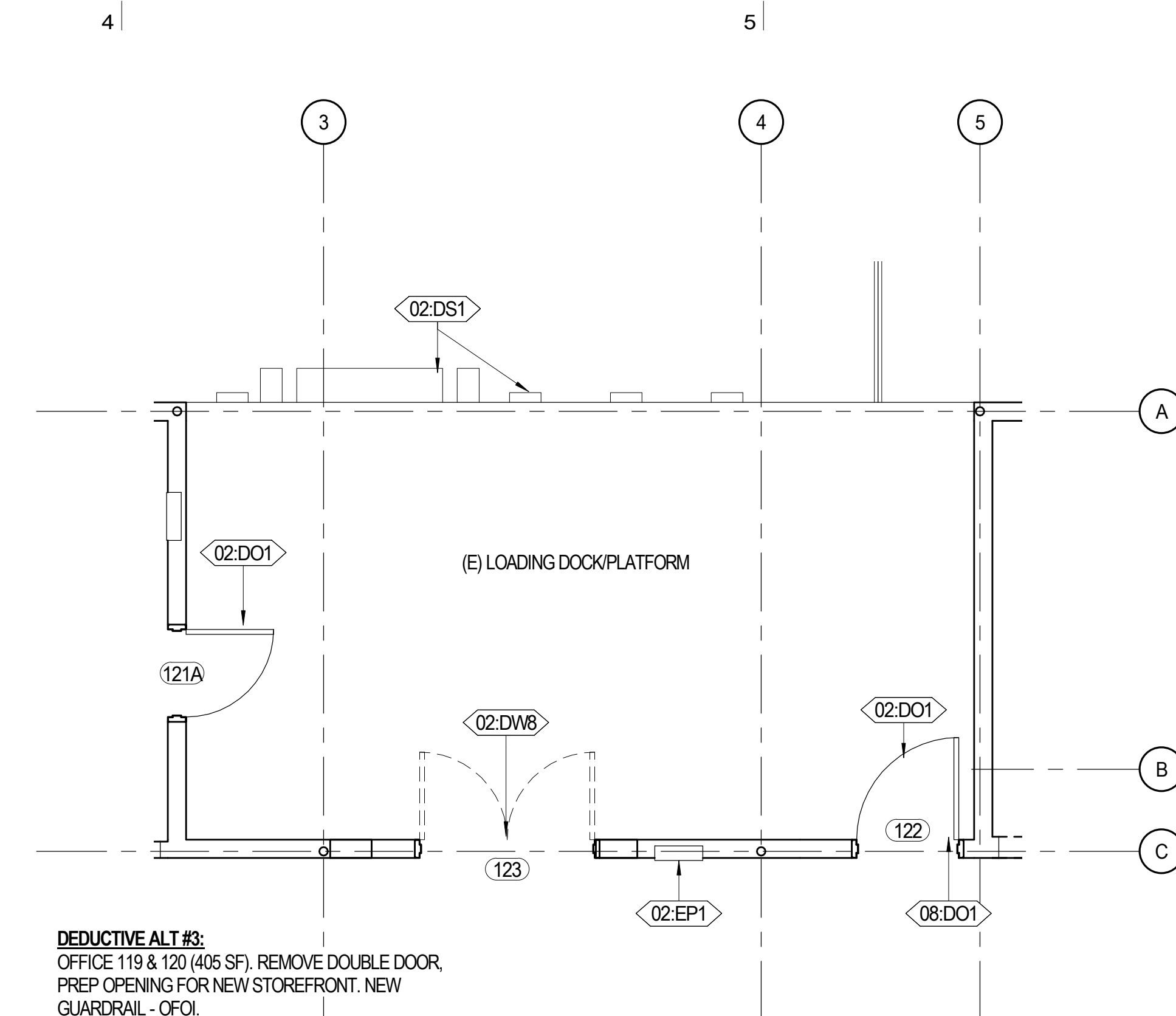

**D4 DEMO FLOOR PLAN DEDUCTIVE ALTERNATE #3**  
A102 1/4" = 1'-0"

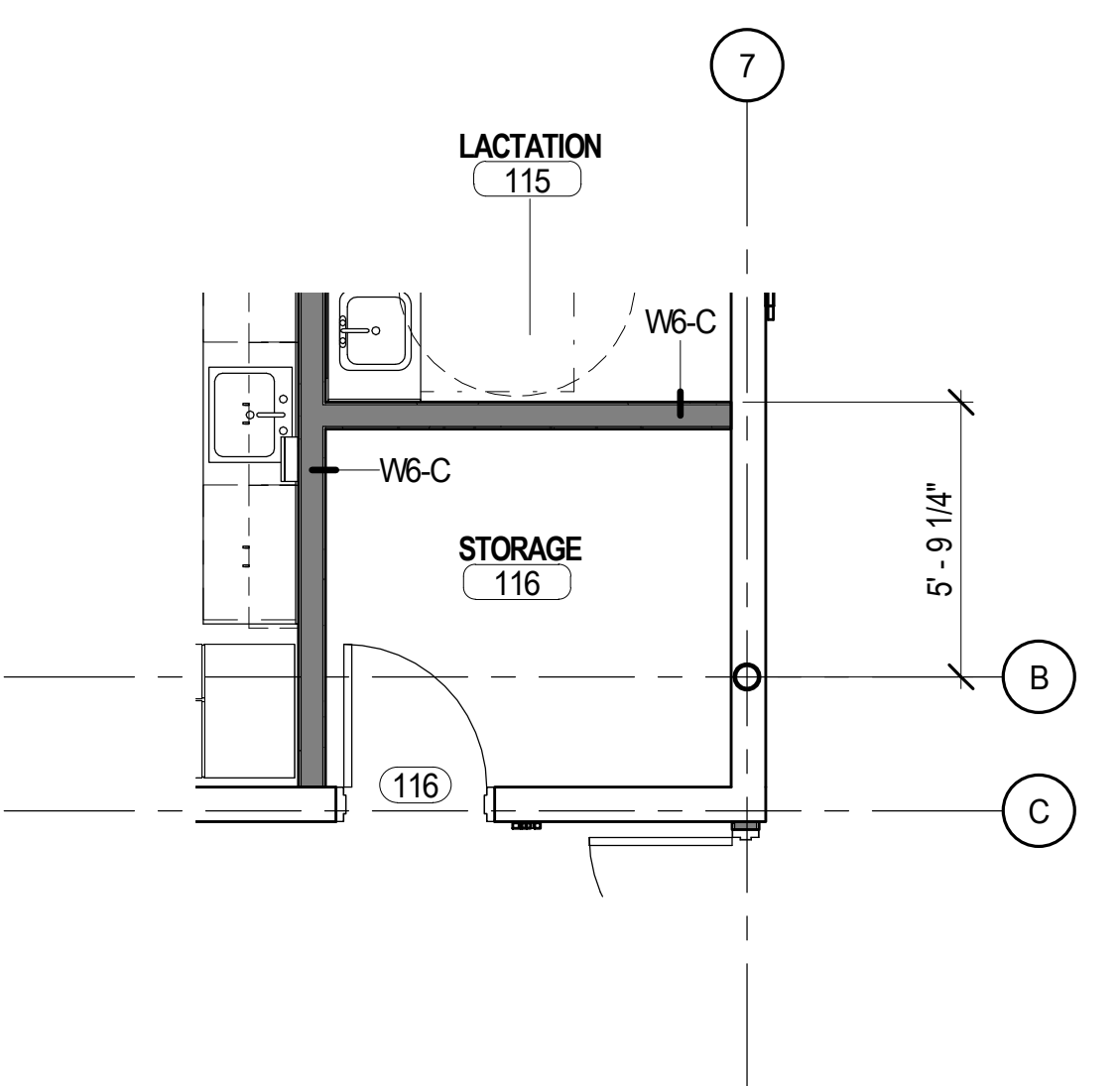

**C3 FLOOR PLAN DEDUCTIVE ALTERNATE #4**  
A102 1/4" = 1'-0"

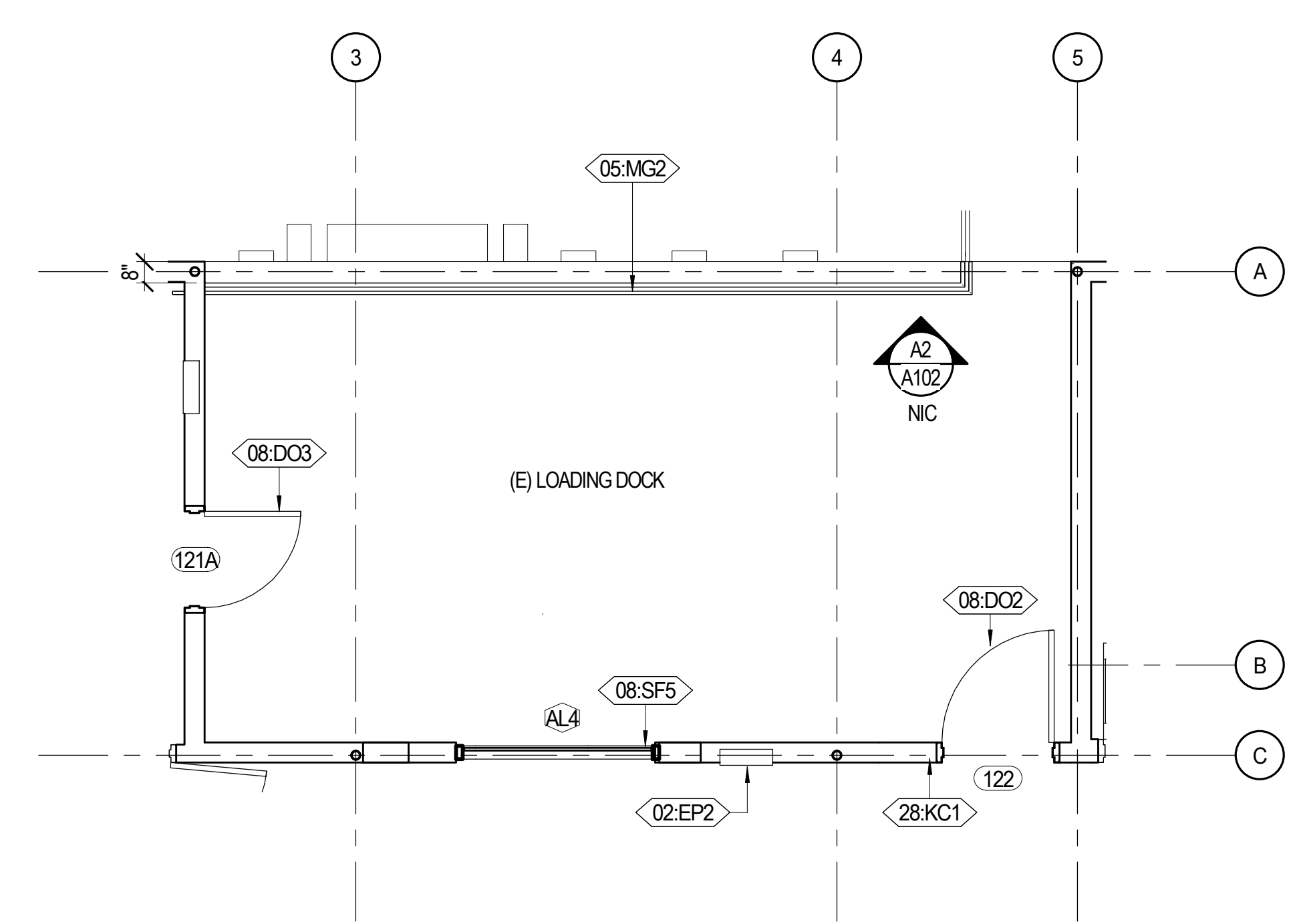

**C4 FLOOR PLAN DEDUCTIVE ALTERNATE #3**  
A102 1/4" = 1'-0"

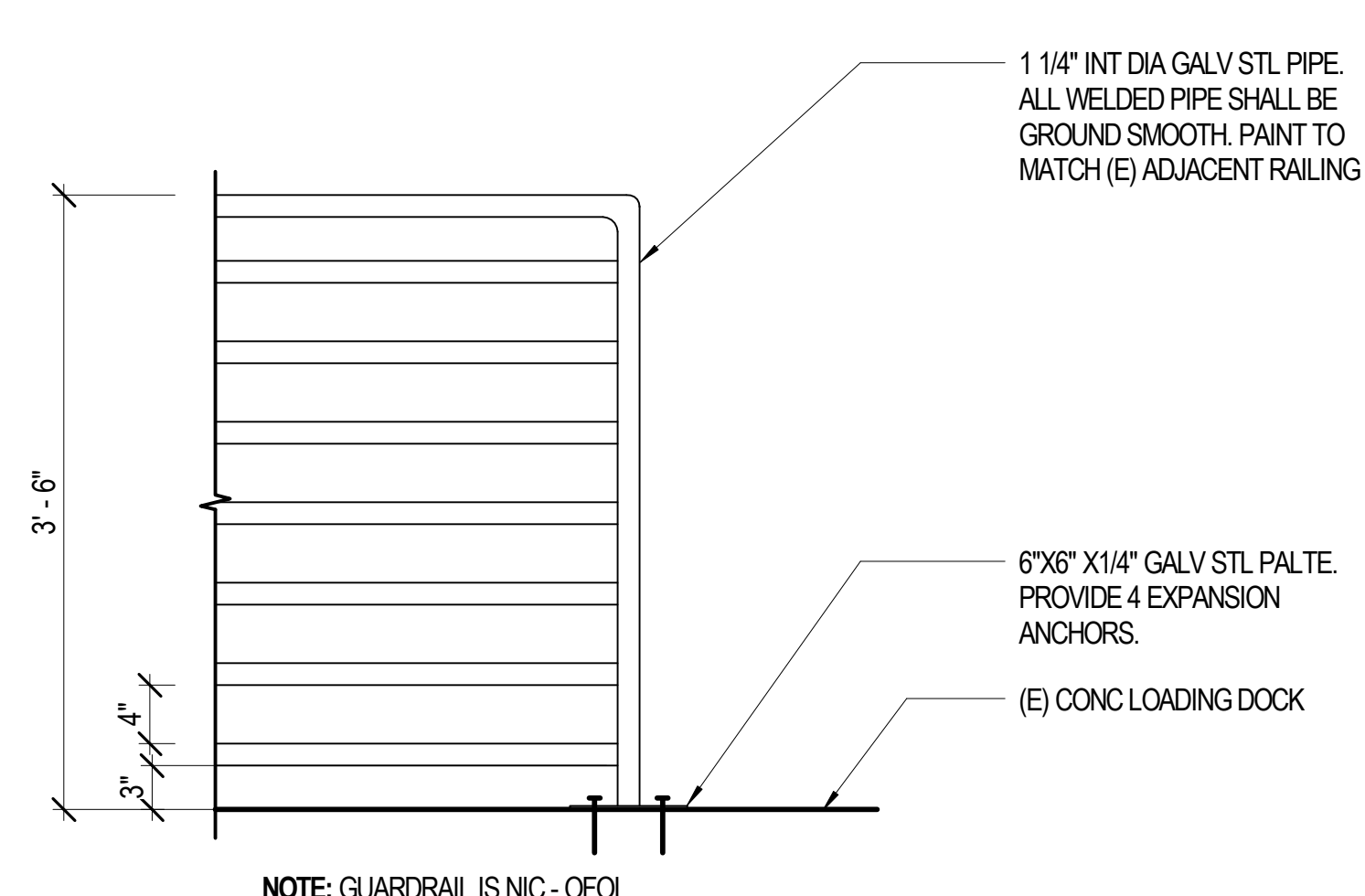

**A2 #3 - OFOI**  
A102 1" = 1'-0"

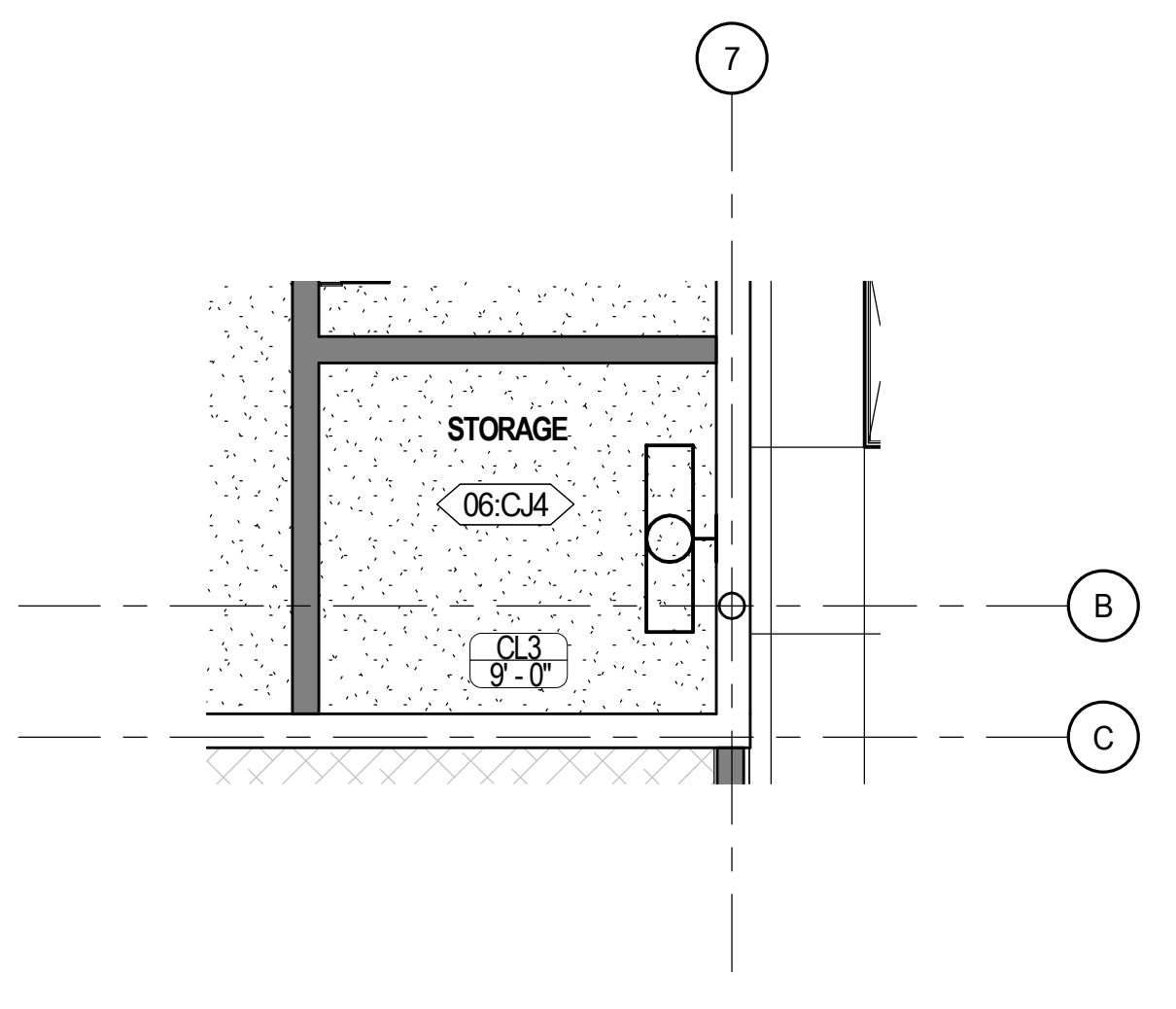

**A3 #4**  
A102 1/4" = 1'-0"

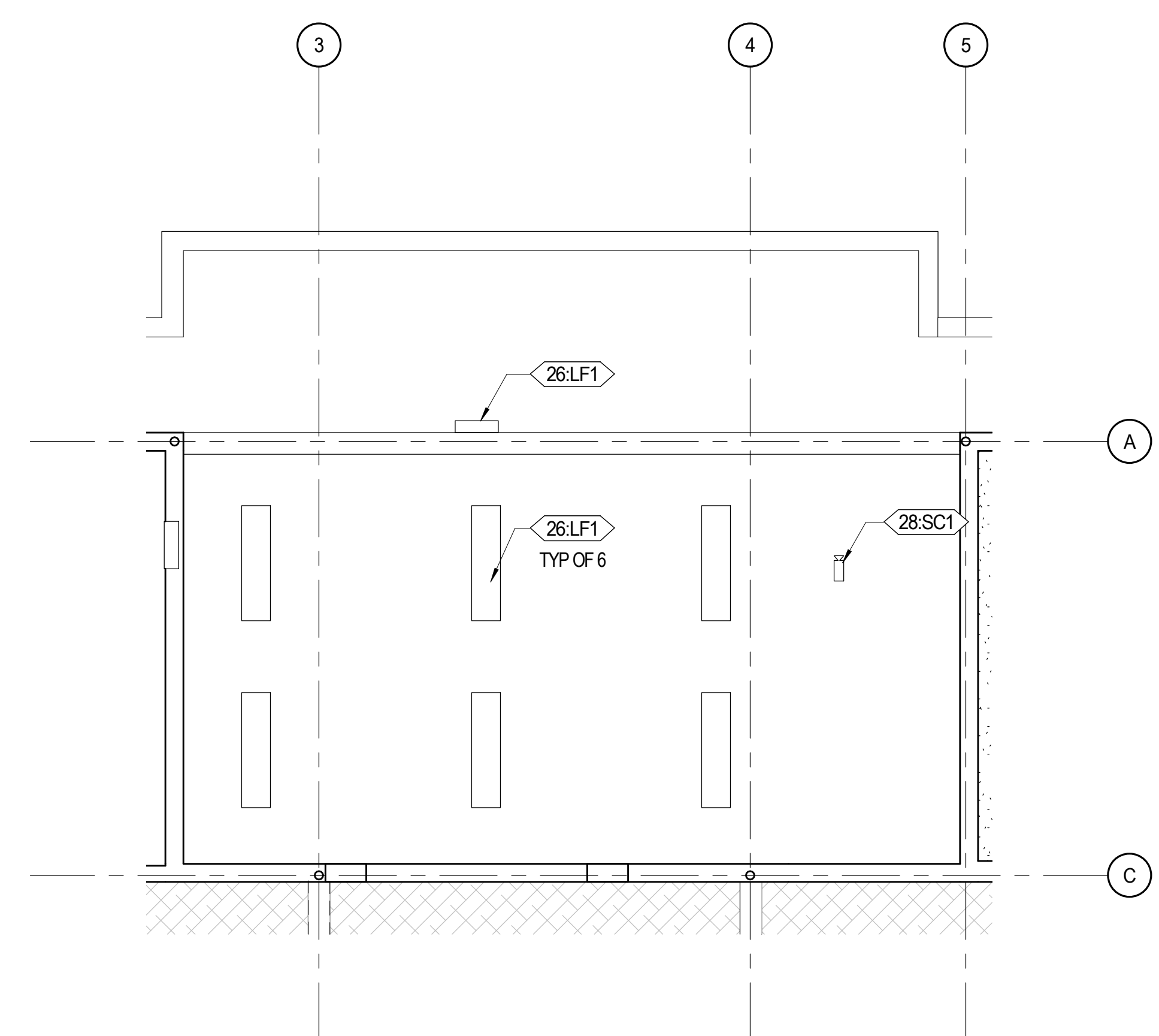

**A4 REFLECTED CEILING PLAN DEDUCTIVE ALTERNATE 3**  
A102 1/4" = 1'-0"

# Date Revision

**CONSTRUCTION DOCUMENTS**

NEXUS PROJ. #: 18117  
CHECKED BY: RP  
DRAWN BY: MR  
DATE: 01.02.2019

**ALTERNATES**

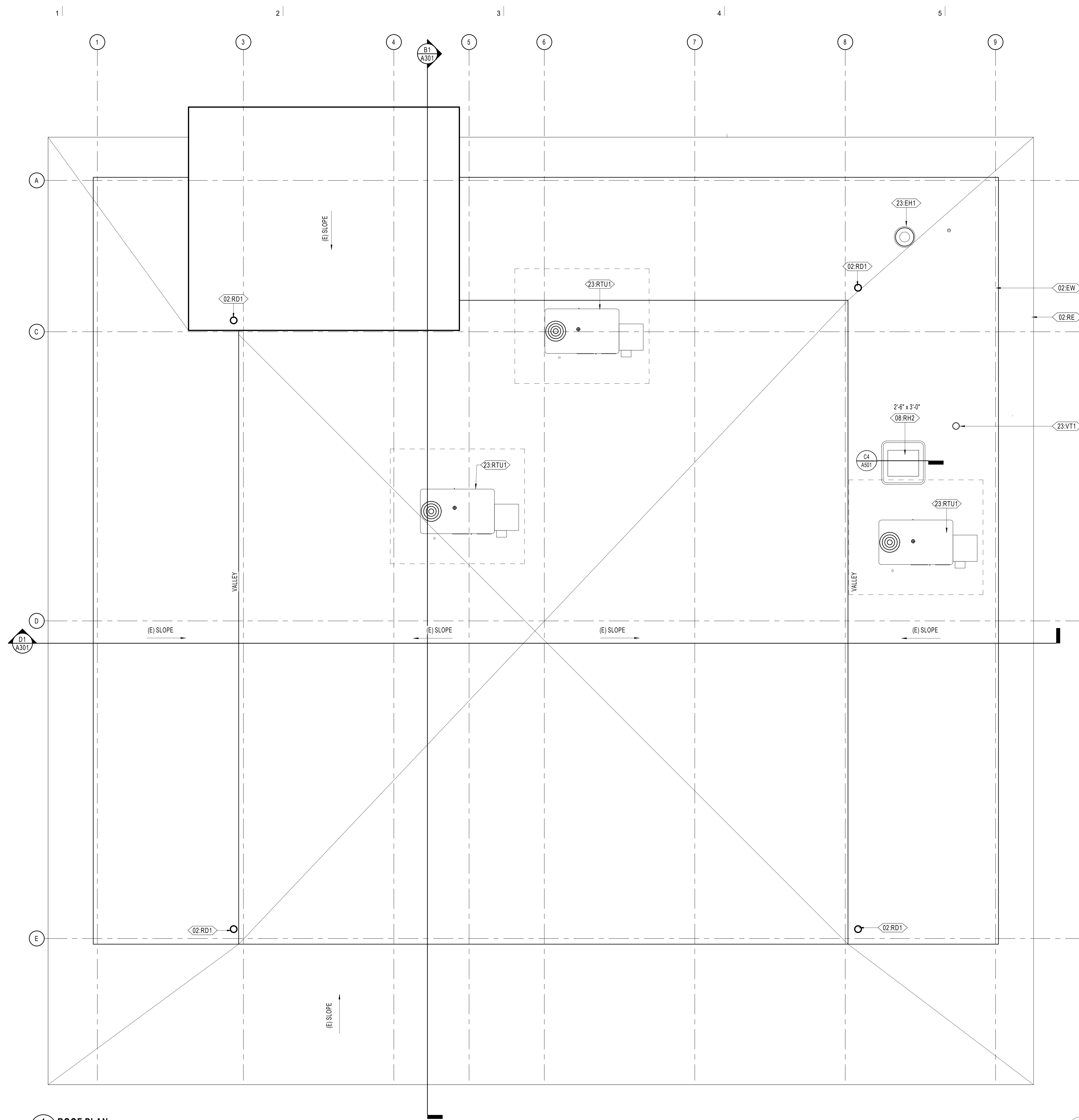

**GENERAL NOTE - ROOF PLAN**

A. COORDINATE ALL PENETRATIONS OF ROOF SYSTEM WITH MECHANICAL AND ELECTRICAL DRAWINGS.

KEYNOTE LEGEND	
Key Value	Keynote Text
02:EW	EXTERIOR WALL BELOW
02:RD1	(E) ROOF & DRAIN TO REMAIN
02:RE	EDGE OF ROOF
08:RH2	(N) ROOF ACCESS HATCH WITH 14" CURB, SAFETY RAIL & LADDER-UP SAFETY POST. SEE DETAIL C5/A501
23:EH1	EXHAUST FAN PER MECHANICAL
23:RTU1	REPLACE (E) ROOF TOP UNIT ON (E) CURB. PROTECT (E) OPENING FOR REUSE. SEE MECHANICAL FOR MORE INFORMATION
23:VT1	VENT THRU ROOF, PER MECHANICAL. SEE DETAIL C5/A701



Architectural NEXUS, Inc.  
930 R Street  
Sacramento, California 95811  
T 916.443.5911  
http://www.archnexus.com

Original drawings remain the property of the Architect and as such the Architect retains total ownership and control. The design represented by these drawings is sold to the client for a one time use, unless otherwise agreed upon in writing by the Architect. © Architectural Nexus, Inc. 2014



**COUNTY OF EL DORADO**  
**HHSA TENANT IMPROVEMENT**  
3368 SANDY WAY  
SOUTH LAKE TAHOE, CA 96150

#	Date	Revision

**CONSTRUCTION DOCUMENTS**

NEXUS PROJ. #: 18117  
CHECKED BY: RP  
DRAWN BY: MR  
DATE: 01.02.2019

**ROOF PLAN**

**1 ROOF PLAN**  
A121 1/4" = 1'-0"

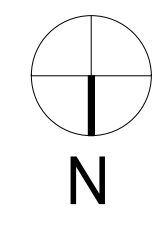

14/02/2019 1:56:54 PM

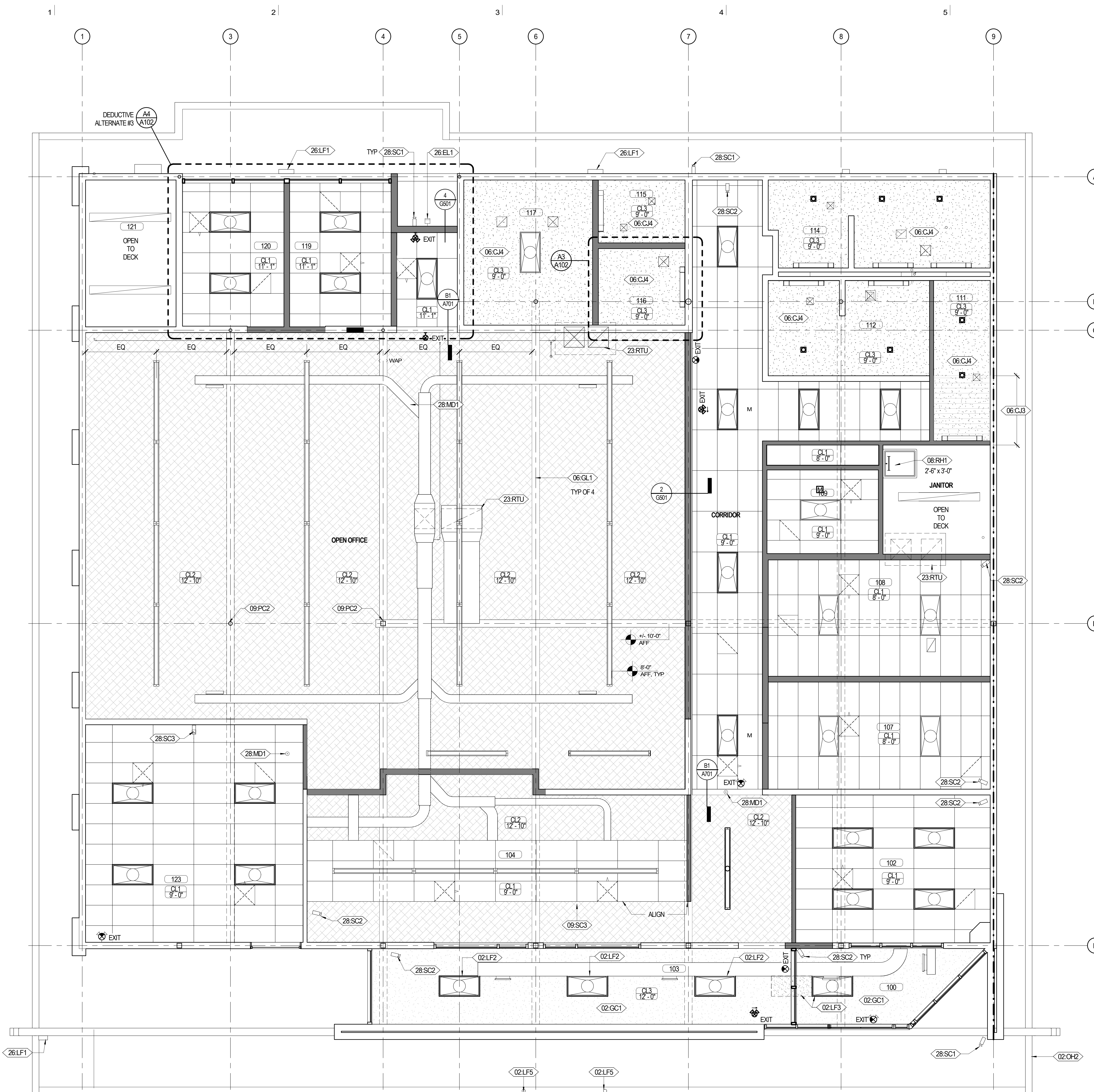

**A1** LEVEL 01 - REFLECTED CEILING PLAN  
 A151 1/4" = 1'-0"

**GENERAL NOTE - RCP**

- A. SEE MECHANICAL AND ELECTRICAL DRAWINGS FOR ADDITIONAL LIGHTING AND DIFFUSER INFORMATION.
- B. THE CEILING HEIGHT SHOWN IN THE ROOM TAG INDICATES THE HEIGHT OF THE DOMINANT CEILING FINISH. SEE ADDITIONAL CEILING FINISH CALLOUTS FOR OTHER CEILING HEIGHT OR FEATURES.
- C. THE CONTRACTOR SHALL COORDINATE ALL TRADES TO ENSURE THAT DESIGNATED CEILING HEIGHTS CAN BE ACHIEVED. NOTIFY ARCHITECT OF ANY CONFLICTS OR CONDITIONS THAT PREVENT THIS FROM OCCURRING BEFORE PROCEEDING WITH THE WORK.

**REFLECTED CEILING PLAN LEGEND**

- 2x4' ACOUSTICAL PANEL CEILING
- 2x4' ACOUSTICAL PANEL CEILING
- GYP. BD. CEILING
- FABRIC SCRIM
- EXPOSED STRUCTURE
- 2x4' DOUBLE LAMP FIXTURE
- WALL MOUNTED LIGHT FIXTURE
- CHAIN SUSPENDED LINEAR
- SUSPENDED LINEAR
- CAMERA
- CEILING MOUNTED LINEAR FIXTURE
- WALL MOUNTED EXTERIOR FIXTURE

**KEYNOTE LEGEND**

Key Value	Keynote Text
02:GC1	(E) GYP BOARD CEILING TO REMAIN. PATCH AS REQUIRED.
02:LF2	(N) 2X4 LIGHT FIXTURE TO BE INSTALLED IN (E) CEILING WHERE PREVIOUS 2X4 FIXTURES WERE DEMOLISHED. PROVIDE TRIM FOR NEW LIGHT FIXTURES AS REQUIRED
02:LF3	(N) 2X4 LIGHT FIXTURE TO BE INSTALLED IN (E) CEILING. PATCH (E) LIGHT FIXTURE OPENING.
02:LF5	(E) LIGHT FIXTURE TO REMAIN
02:OH2	(E) OVERHANG
06:CJ3	NEW 2X4 CEILING JOISTS. MATCH EXISTING ADJACENT IN SPACING AND HEIGHT.
06:CJ4	(E) CEILING FRAMING TO REMAIN
06:GL1	(E) EXPOSED GLUED-LAMINATED BEAM TO REMAIN. CLEAN AS REQUIRED
08:RH1	(N) ROOF HATCH SEE DETAIL C4/A501. PROVIDE LADDER FOR ACCESS TO OPENING
09:PC2	PAINT (E) EXPOSED COLUMN
09:SC3	CONTINUE SCRIM SHEET ABOVE DROPPED CEILING
23:RTU	(E) ROOF TOP UNIT LOCATION (ABOVE). COORDINATE LOCATION WITH (N) MECHANICAL UNITS - UTILIZE (E) OPENING
26:EL1	SURFACE MOUNTED EXTERIOR LIGHT FIXTURE; SEE ELECTRICAL
26:LF1	(E) LIGHT FIXTURE TO REMAIN. PAINT ALL EXPOSED SURFACE MOUNTED CONDUIT & ACCESSORIES TO MATCH ADJACENT SURFACE. REFURBISHING OF LIGHT FIXTURE BY OWNER, AS REQUIRED
28:MD1	MOTION DETECTOR W/ SOUND RECORDING
28:SC1	EXTERIOR, VANDAL PROOF SECURITY CAMERA W/ NIGHT VISION & HEATER, TYP OF 3 OFC
28:SC2	INTERIOR SECURITY CAMERA, TYP OF 7 OFCI
28:SC3	INTERIOR MEDIA CAMERA, OFOI

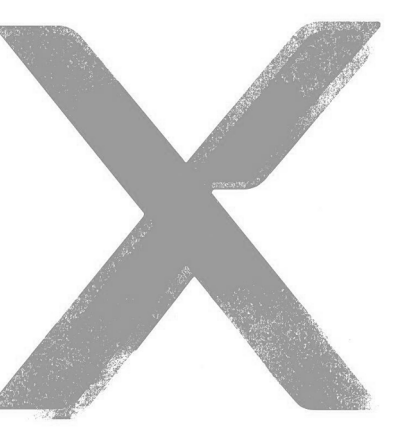

ARCH | NEXUS  
 Architectural NEXUS, Inc.  
 930 R Street  
 Sacramento, California 95811  
 T 916.443.5911  
 http://www.archnexus.com

Original drawings remain the property of the Architect and as such the Architect retains total ownership and control. The design represented by these drawings is sold to the client for a one time use, unless otherwise agreed upon in writing by the Architect.  
 © Architectural Nexus, Inc. 2014



**COUNTY OF EL DORADO**  
**HHSA TENANT IMPROVEMENT**  
 3368 SANDY WAY  
 SOUTH LAKE TAHOE, CA 96150

#	Date	Revision

**CONSTRUCTION DOCUMENTS**

NEXUS PROJ. #: 18117  
 CHECKED BY: RP  
 DRAWN BY: MR  
 DATE: 01.02.2019

**REFLECTED CEILING PLAN**

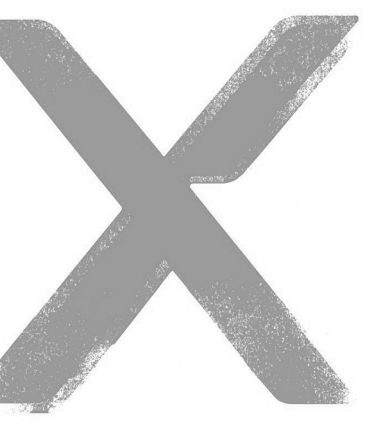

ARCH | NEXUS

Architectural NEXUS, Inc.  
930 R Street  
Sacramento, California 95811  
T 916.443.5911  
http://www.archnexus.com

Original drawings remain the property of the Architect and as such the Architect retains total ownership and control. The design represented by these drawings is sold to the client for a one time use, unless otherwise agreed upon in writing by the Architect. © Architectural Nexus, Inc. 2014



COUNTY OF EL DORADO  
**HHSA TENANT IMPROVEMENT**  
3368 SANDY WAY  
SOUTH LAKE TAHOE, CA 96150

KEYNOTE LEGEND	
Key Value	Keynote Text
02:DP1	(E) DRAIN PIPE TO REMAIN
02:LV2	(E) LOUVER TO REMAIN. INFILL WALL
05:MR1	1/4" THICK GALVANIZED STL PLATE GUARDRAIL. PAINT TO MATCH BUILDING SIDING, NIC - OFCI
08:IW1	INFILL (E) OPENING & INSTALL NEW WINDOW. INCLUDE IN BASE BID
08:WA1	ADD ALT #1 REPLACE EXISTING WINDOWS WITH NEW FRAME AND REFLECTIVE GLAZING.
09:EX1	INFILL OPENING IN (E) 1 HOUR WALL. REUSE SIDING FROM LOADING DOCK AREA
09:EX2	INFILL OPENING IN (E). REUSE SIDING FROM LOADING DOCK AREA
09:EX3	DEDUCTIVE ALT #3; INFILL WALL IN (E) WALL. PROVIDE NEW REDWOOD PLYWOOD SIDING & TRIM TO MATCH (E)
23:RTU1	REPLACE (E) ROOF TOP UNIT ON (E) CURB. PROTECT (E) OPENING FOR REUSE. SEE MECHANICAL FOR MORE INFORMATION
23:SCU	SPLIT SYSTEM OUTDOOR UNIT PER MECHANICAL
26:EL1	SURFACE MOUNTED EXTERIOR LIGHT FIXTURE; SEE ELECTRICAL
26:LF1	(E) LIGHT FIXTURE TO REMAIN. PAINT ALL EXPOSED SURFACE MOUNTED CONDUIT & ACCESSORIES TO MATCH ADJACENT SURFACE. REFURBISHING OF LIGHT FIXTURE BY OWNER, AS REQUIRED
28:SC1	EXTERIOR, VANDAL PROOF SECURITY CAMERA W/ NIGHT VISION & HEATER, TYP OF 3 OFCI

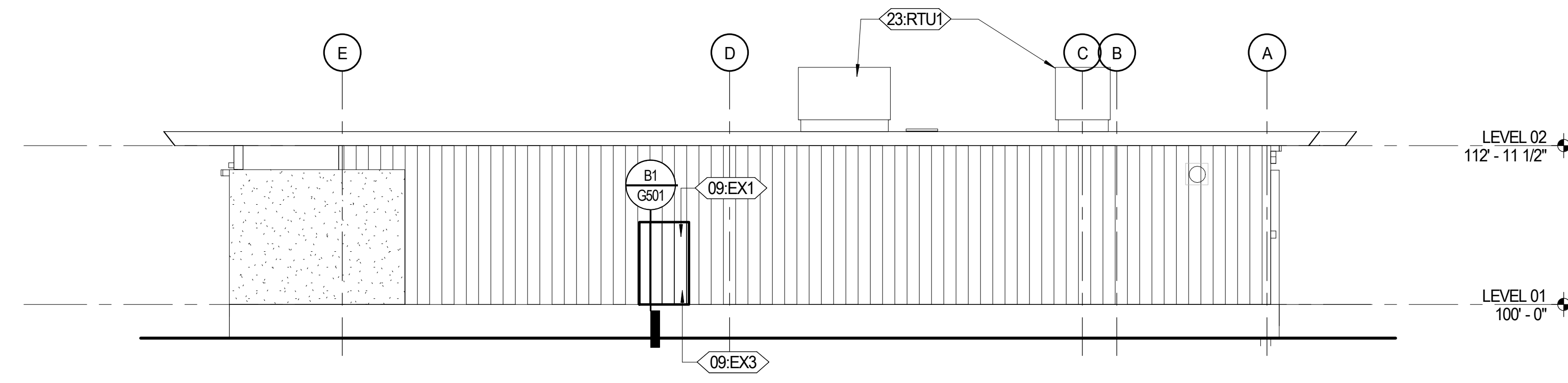

**D3 WEST ELEVATION**  
A201 1/8" = 1'-0"

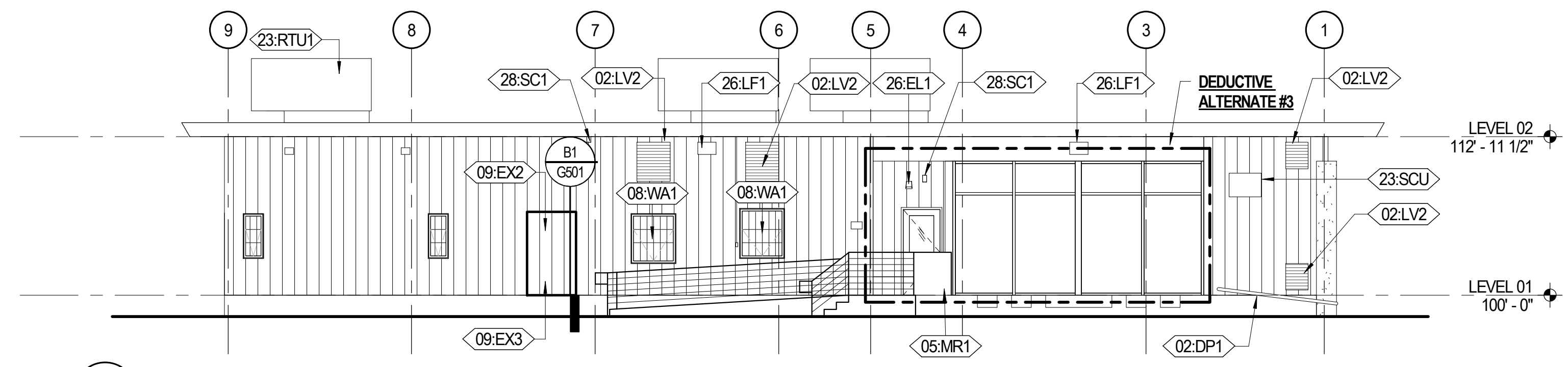

**C3 SOUTH ELEVATION**  
A201 1/8" = 1'-0"

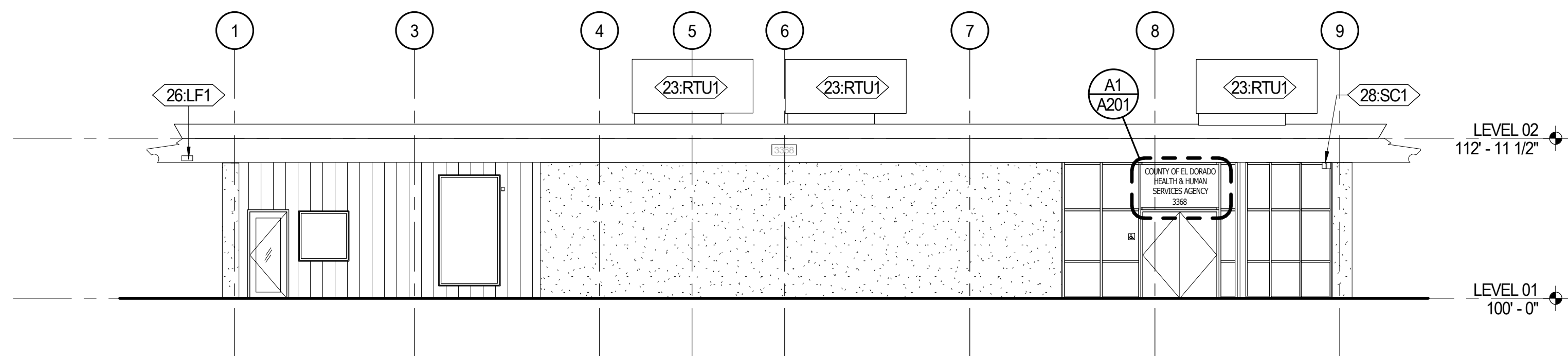

**B3 NORTH ELEVATION**  
A201 1/8" = 1'-0"

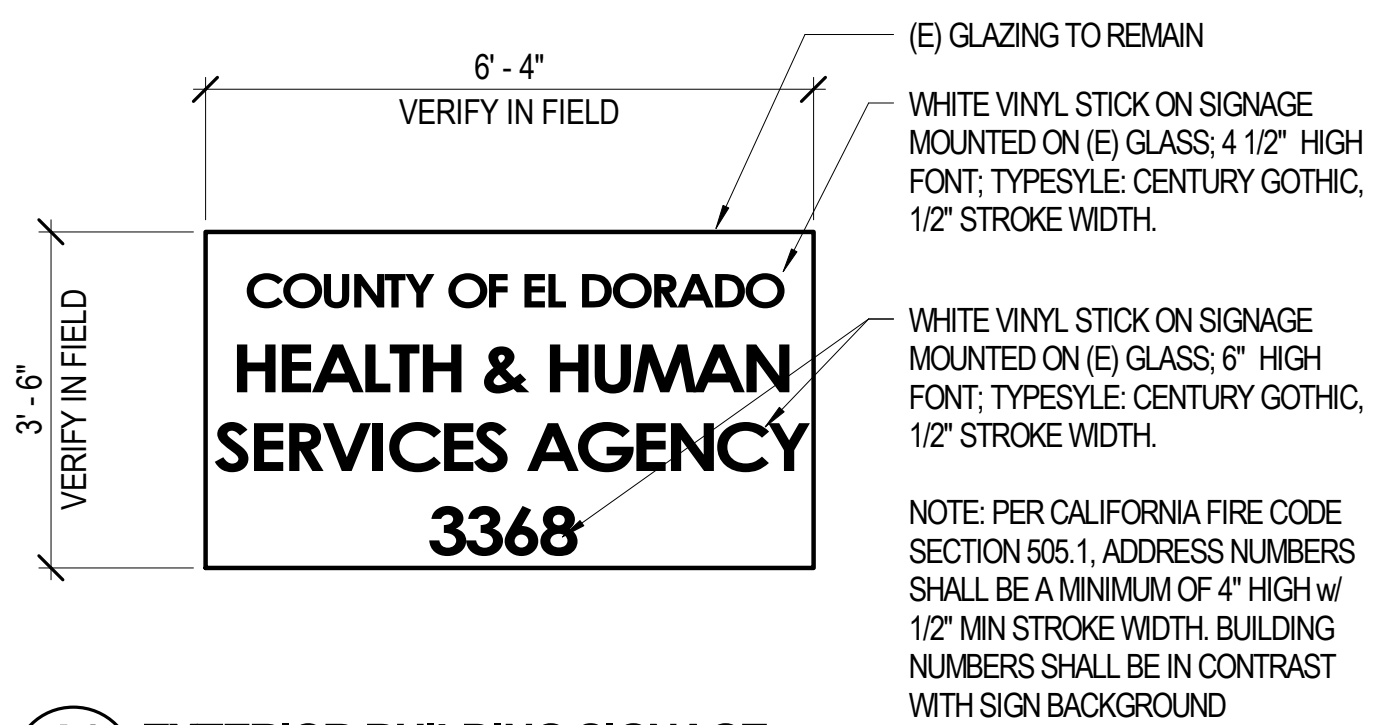

**A1 EXTERIOR BUILDING SIGNAGE**  
A201 1/2" = 1'-0"

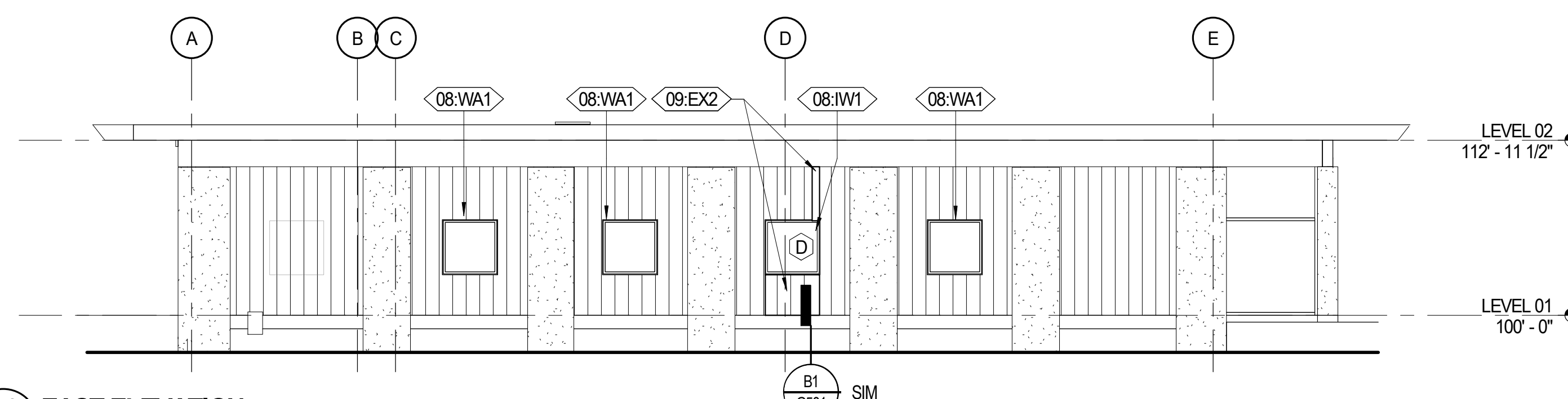

**A3 EAST ELEVATION**  
A201 1/8" = 1'-0"

# Date Revision

**CONSTRUCTION DOCUMENTS**

NEXUS PROJ. #: 18117  
CHECKED BY: RP  
DRAWN BY: MR  
DATE: 01.02.2019

**BUILDING ELEVATIONS**

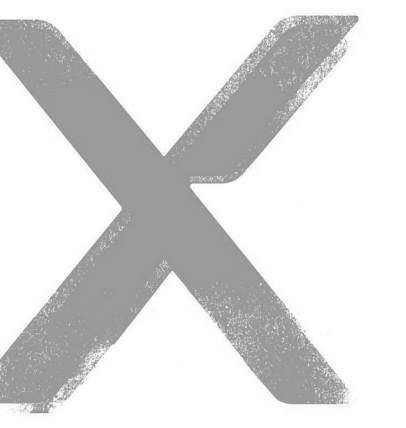

ARCH | NEXUS

Architectural NEXUS, Inc.  
930 R Street  
Sacramento, California 95811  
T 916.443.5911  
http://www.archnexus.com

Original drawings remain the property of the Architect and as such the Architect retains total ownership and control. The design represented by these drawings is sold to the client for a one time use, unless otherwise agreed upon in writing by the Architect.  
© Architectural Nexus, Inc. 2014



COUNTY OF EL DORADO  
**HHSA TENANT IMPROVEMENT**  
3368 SANDY WAY  
SOUTH LAKE TAHOE, CA 96150

### GENERAL NOTE - INTERIOR ELEVATION

- A. ENSURE THAT ALL REQUIRED FIXTURE AND CABINET CLEARANCES AND OTHER REQUIREMENTS ARE MAINTAINED PURSUANT TO ADA AND ANSI A117.1. SEE SHEET G701 FOR GENERAL GUIDANCE ON COMMON MOUNTING HEIGHTS AND ACCESSIBILITY COMPLIANCE.
- B. PROVIDE BLOCKING/BACKING AS NECESSARY FOR MOUNTING OF WALL-MOUNTED CABINETS, FIXTURES AND EQUIPMENT PER MANUFACTURERS RECOMMENDATIONS. COORDINATE THIS REQUIREMENT THROUGH ALL FLOOR PLANS, EQUIPMENT PLANS, AND INTERIOR ELEVATIONS.
- C. ON ALL EXPOSED CABINET SIDES, INCLUDING KNEE OPENINGS, PROVIDE FINISHED FACE TO MATCH CABINET FRONTS. PROVIDE SIDESPLASHES WHENEVER COUNTERTOPS ARE ADJACENT TO WALLS.

KEYNOTE LEGEND	
Key Value	Keynote Text
06:CB1	COUNTER BRACING, SEE DETAIL 2/A501
06:PB1	3/4" PARTICLE BOARD
06:PB2	3/4" WOOD-VENEERED PARTICLE BOARD
06:PL1	PLASTIC LAMINATE
06:PL2	PLASTIC LAMINATE
06:SS1	SOLID SURFACE
06:WB1	CONT. WOOD BACKER STRIP
08:RH4	ROOF HATCH LADDER. SEE DETAIL B3/A501
08:SP1	CR LAURENCE 725A CRL SATIN ANODIZED SEMICIRCULAR TICKET WINDOW W/ 10 1/2" X 5 1/4" OPENINGS & LATCHING COVER PLATE
08:SP2	CR LAURENCE CRL ANODIZED ALUMINUM NO-DRAFT SPEAK-THRU, SATIN ALUMINUM, 834A
08:TW2	TRANSACTION WINDOW: 1/4" FULLY TEMPERED FLOAT GLASS; SEALANT TYPE AS RECOMMENDED BY MFR.
09:AP2	2X4 LAY-IN ACOUSTICAL PANEL CEILING W/ 4" PERIMETER TRIM.
09:FP1	PAINTED FINISH; SEE FINISH LEGEND
09:FRL1	FIBER REINFORCED LAMINATE, FRL1 SEE FINISH LEGEND
09:FRP1	FIBERGLASS REINFORCED PANEL FRP1 SEE FINISH LEGEND
09:FS	SCHEDULED FINISH
09:P2	SEMI-GLOSS PAINT, P2 SEE FINISH LEGEND
09:PV1	PROVIDE PRIVACY FILM AT SHADED AREA
09:WB1	SCHEDULED WALL BASE; SEE FINISH SCHEDULE
09:WR1	PROVIDE 6" DIAMETER OPENING IN COUNTER FOR ACCESS TO WASTE RECEPTACLE BELOW. LOCATE SO THAT WASTE RECEPTACLE WILL NOT OBSTRUCT ACCESSIBLE FLOOR CLEARANCE TO LAVATORY
10:BC1	BABY CHANGING STATION
10:GB1	42" GRAB BAR
10:GB2	36" GRAB BAR
10:GB5	1 1/2" DIAMETER PROTECTIVE METAL PIPE RAIL AT DRINKING FOUNTAIN ALCOVE.
10:MR1	MIRROR (24"X36")
10:PT1	PAPER TOWEL DISPENSER
10:SC1	TOILET SEAT COVER DISPENSER
10:SN1	SANITARY NAPKIN DISPOSAL UNIT
10:TP1	TOILET PARTITION
10:TT1	TOILET TISSUE DISPENSER
11:AV1	AUDIO-VISUAL EQUIPMENT
21:FEC	RE-USED SEMI-RECESSED FIRE EXTINGUISHER CABINET. SEE DETAIL C3/A701
22:DF1	DRINKING FOUNTAIN. SEE DETAIL C3/G701 FOR MOUNTING REQUIREMENTS
22:TT2	FLOOR MOUNT TOILET
22:UW1	WALL MOUNT URINAL
22:WS1	WALL MOUNT SINK
26:LW1	WALL MOUNTED LIGHT FIXTURE; SEE ELECTRICAL
26:TV1	WALL MOUNT TV SCREEN & CAMERA. OFOL CONTRACTOR TO PROVIDE BACKING.
28:PB1	PANIC BUTTON

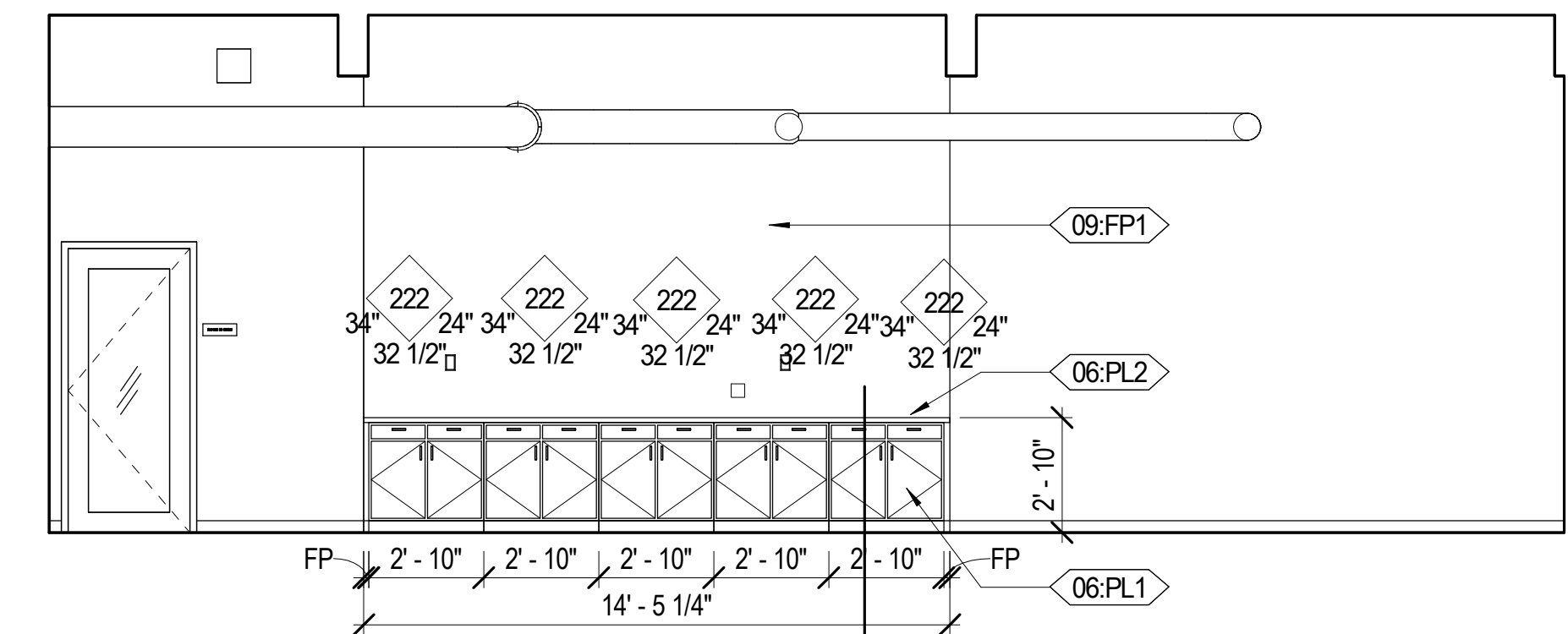

**E1 STAFF WORK BOOTHS 105 - NORTH**  
A251 1/4" = 1'-0"

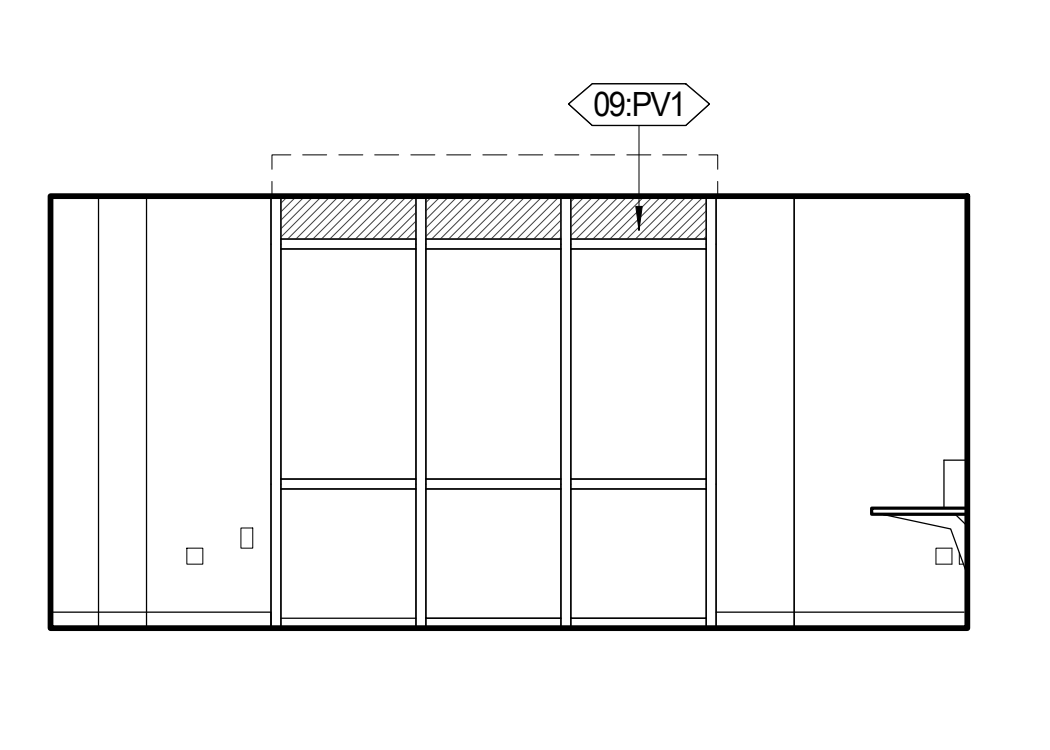

**E2 RECEPTION 102 - SOUTH**  
A251 1/4" = 1'-0"

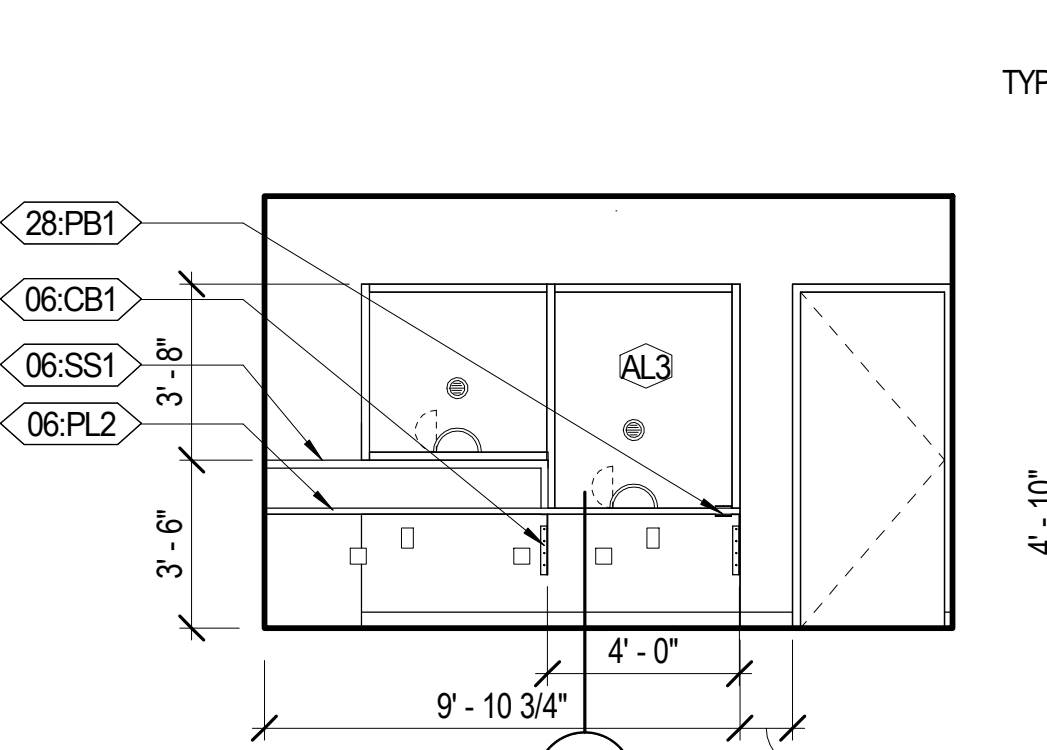

**E3 RECEPTION 102 - EAST**  
A251 1/4" = 1'-0"

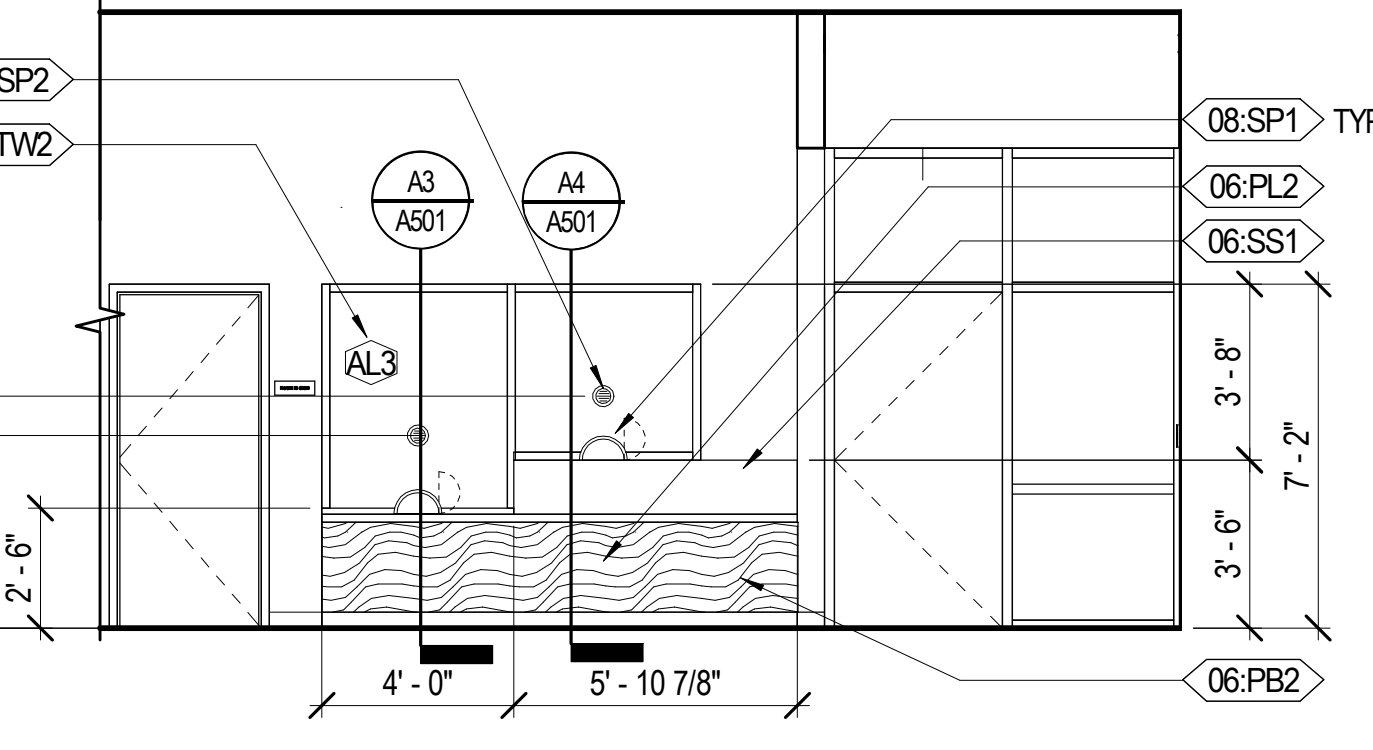

**E4 CORRIDOR 106**  
A251 1/4" = 1'-0"

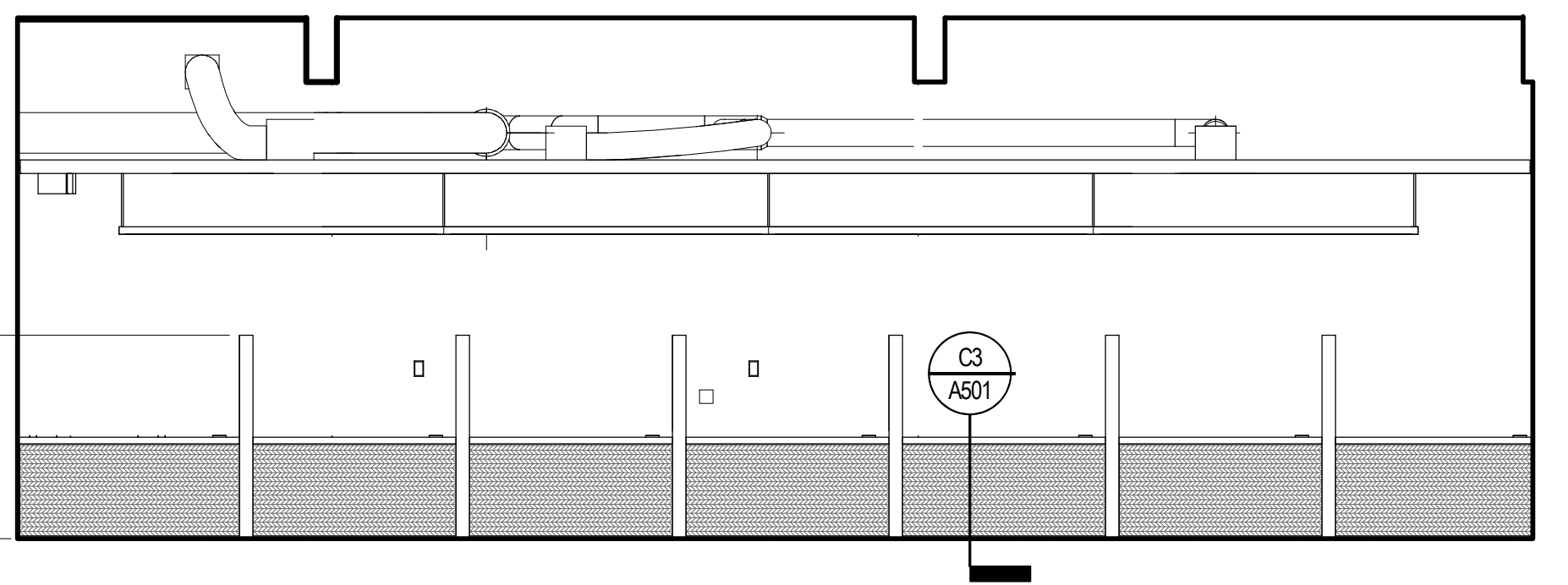

**D1 INTERVIEW BOOTHS 104**  
A251 1/4" = 1'-0"

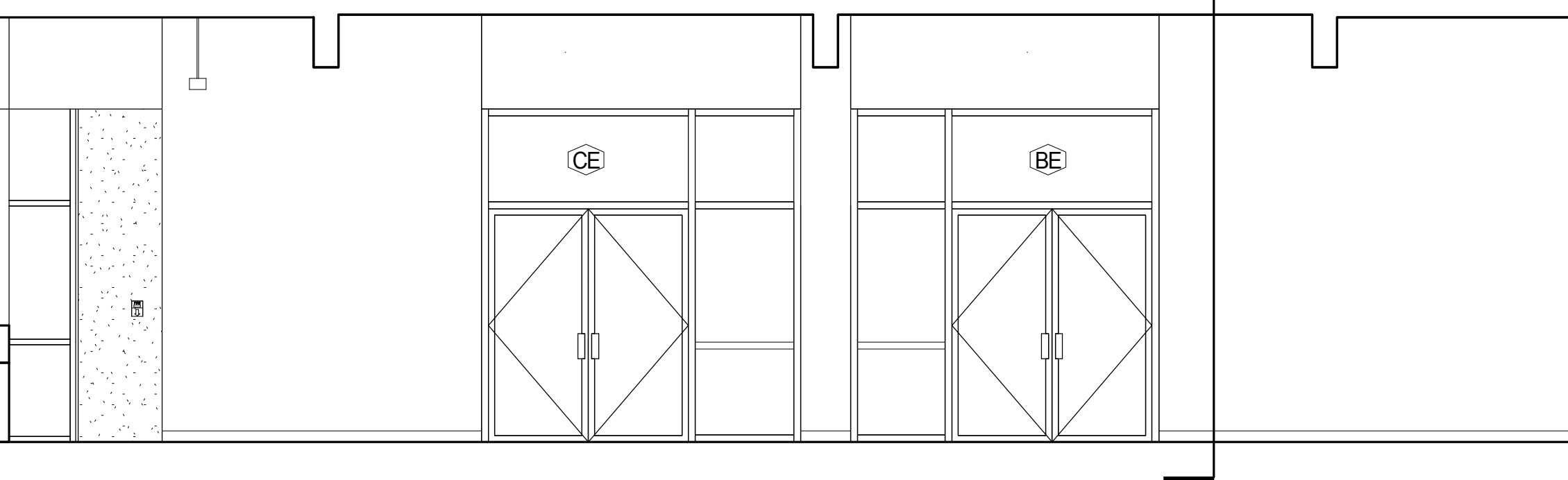

**D2 INTERVIEW BOOTH 104 - NORTH**  
A251 1/4" = 1'-0"

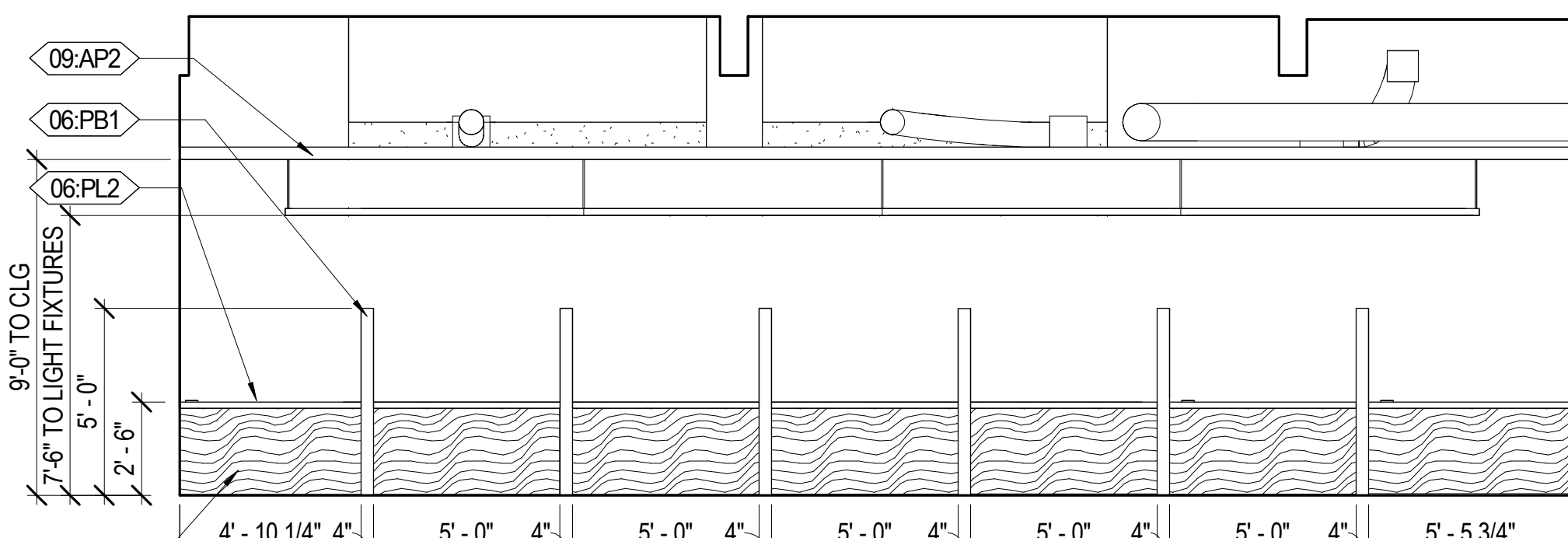

**D3 STAFF WORK BOOTHS 105 - NORTH**  
A251 1/4" = 1'-0"

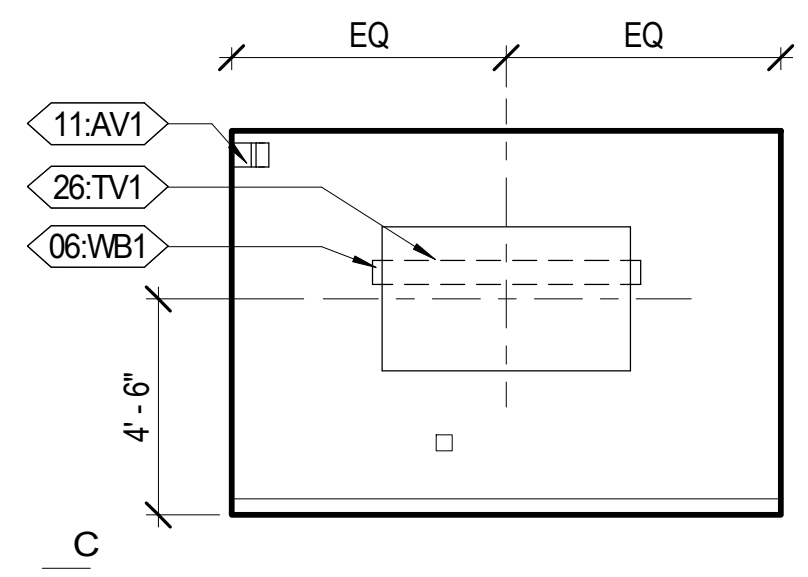

**C1 LARGE CONFERENCE 108 - WEST**  
A251 1/4" = 1'-0"

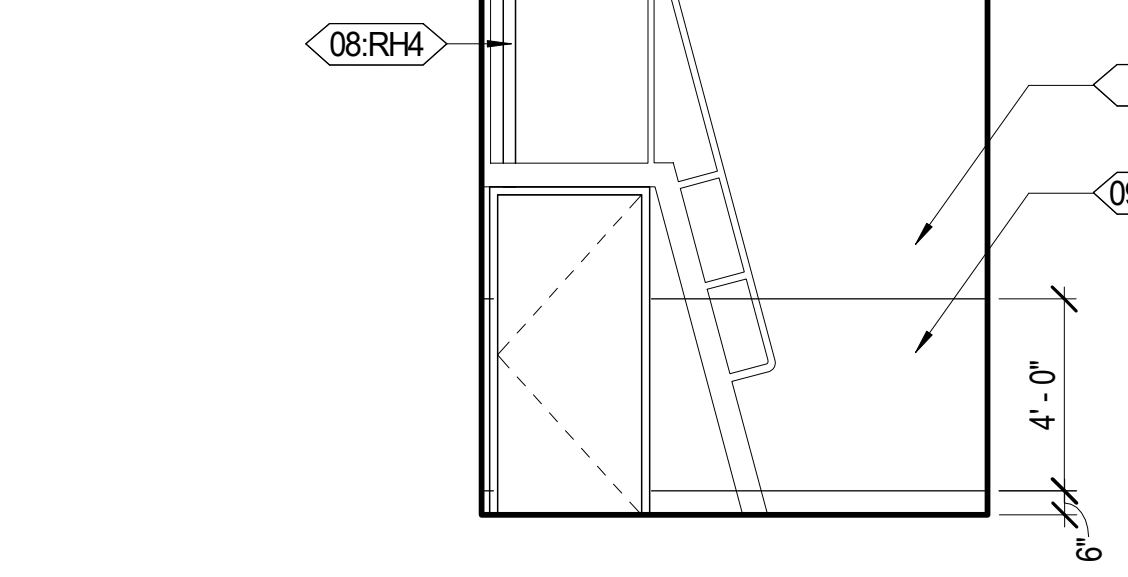

**C2 JANITOR 110 - SOUTH**  
A251 1/4" = 1'-0"

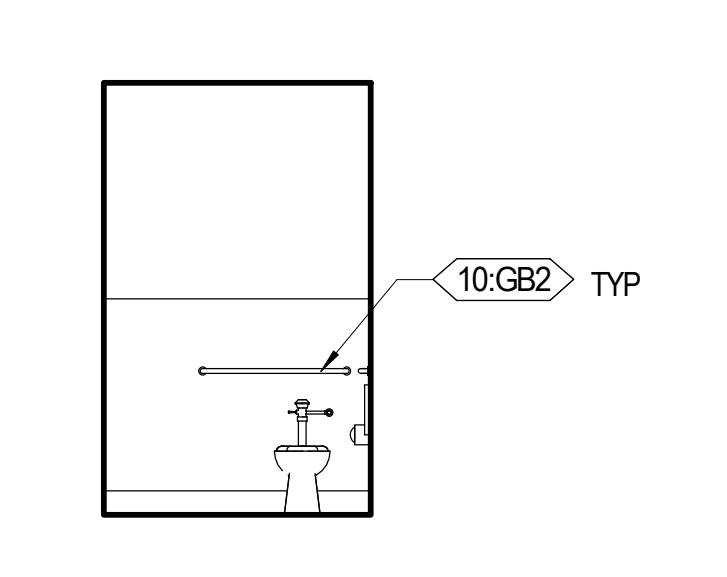

**C3 TOILET 111 - SOUTH**  
A251 1/4" = 1'-0"

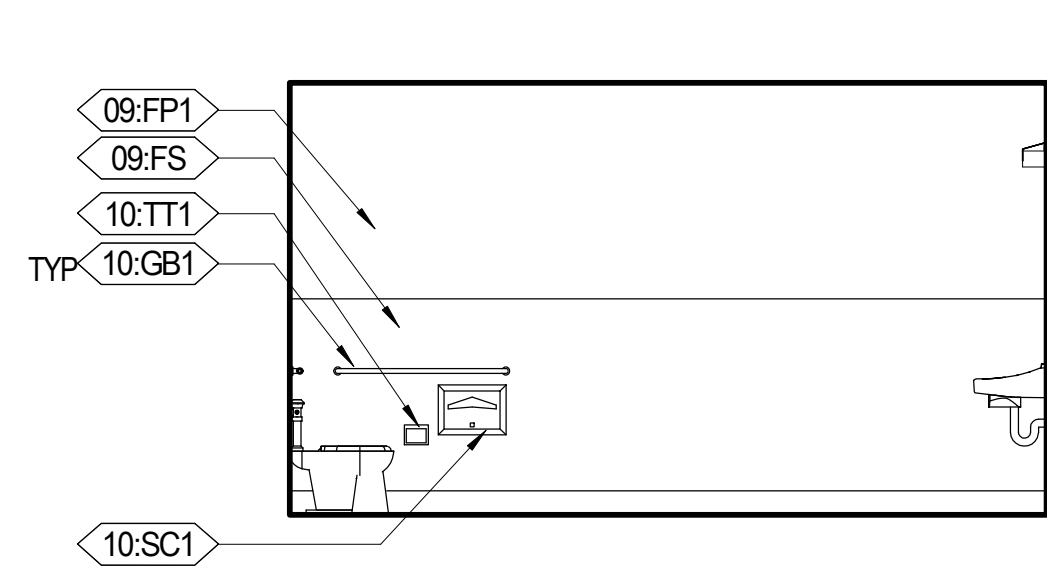

**C4 TOILET 111 - WEST**  
A251 1/4" = 1'-0"

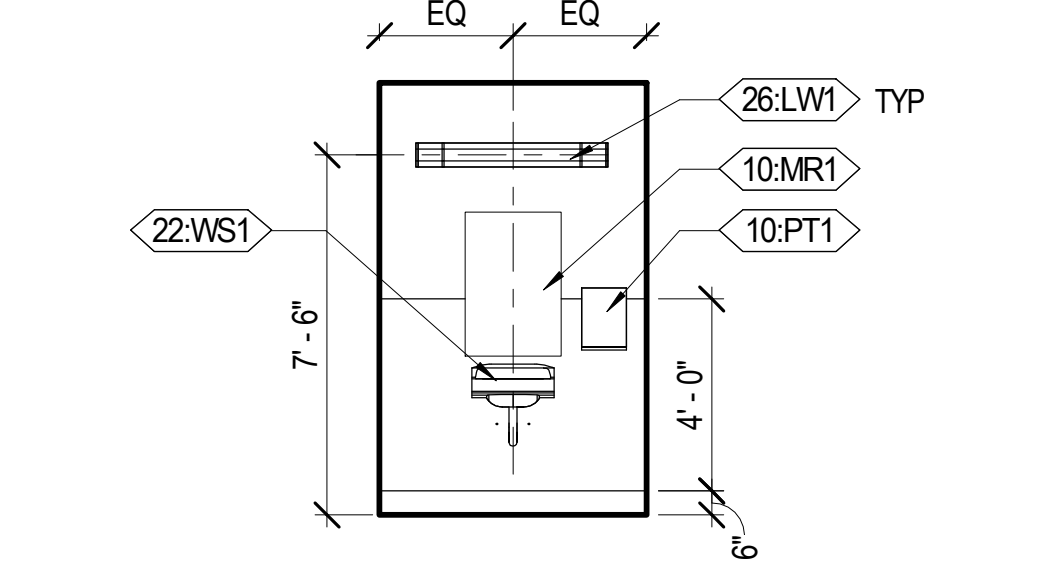

**C5 TOILET 111 - NORTH**  
A251 1/4" = 1'-0"

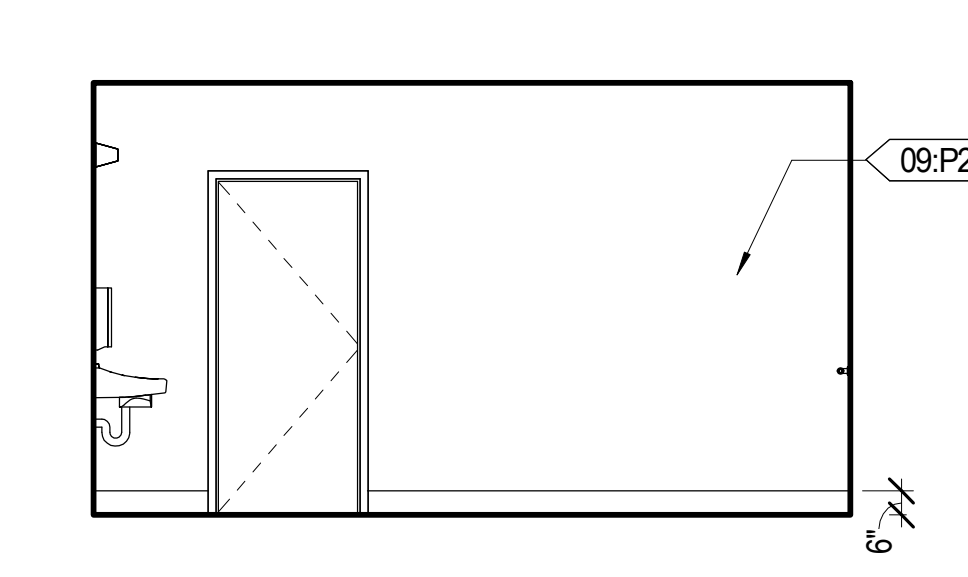

**C6 TOILET 111 - EAST**  
A251 1/4" = 1'-0"

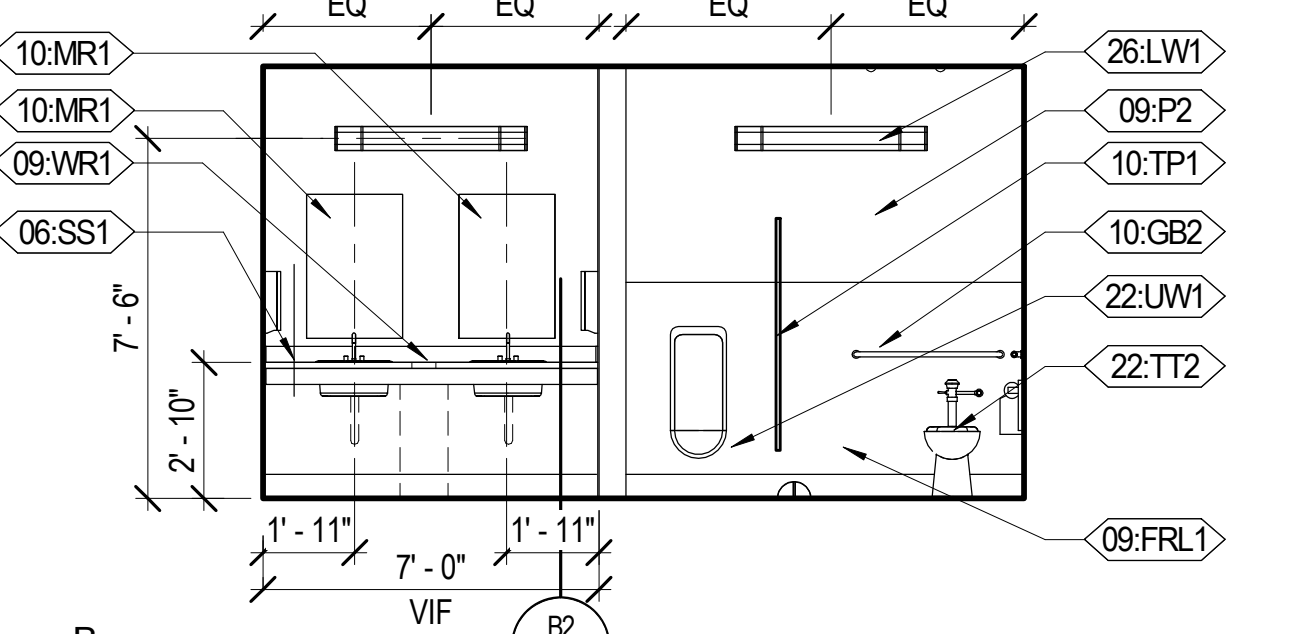

**B1 MEN'S RESTROOM 112 - SOUTH**  
A251 1/4" = 1'-0"

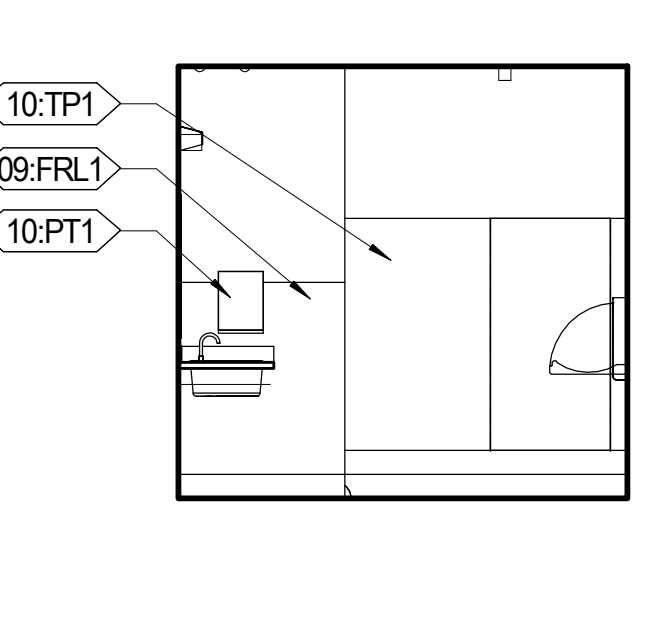

**B2 MEN'S RESTROOM 112 - WEST**  
A251 1/4" = 1'-0"

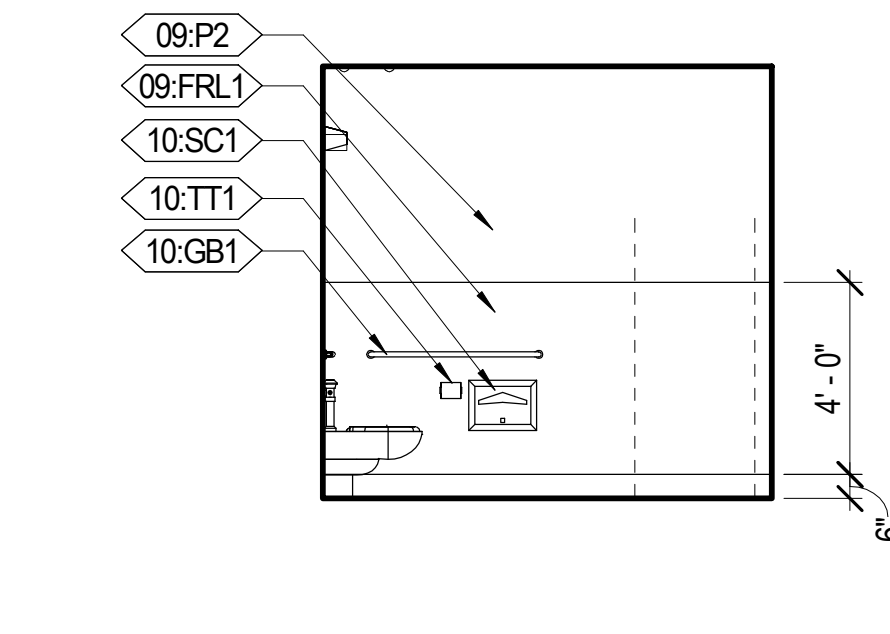

**B3 MEN'S RESTROOM 112 - ACC. STALL - WEST**  
A251 1/4" = 1'-0"

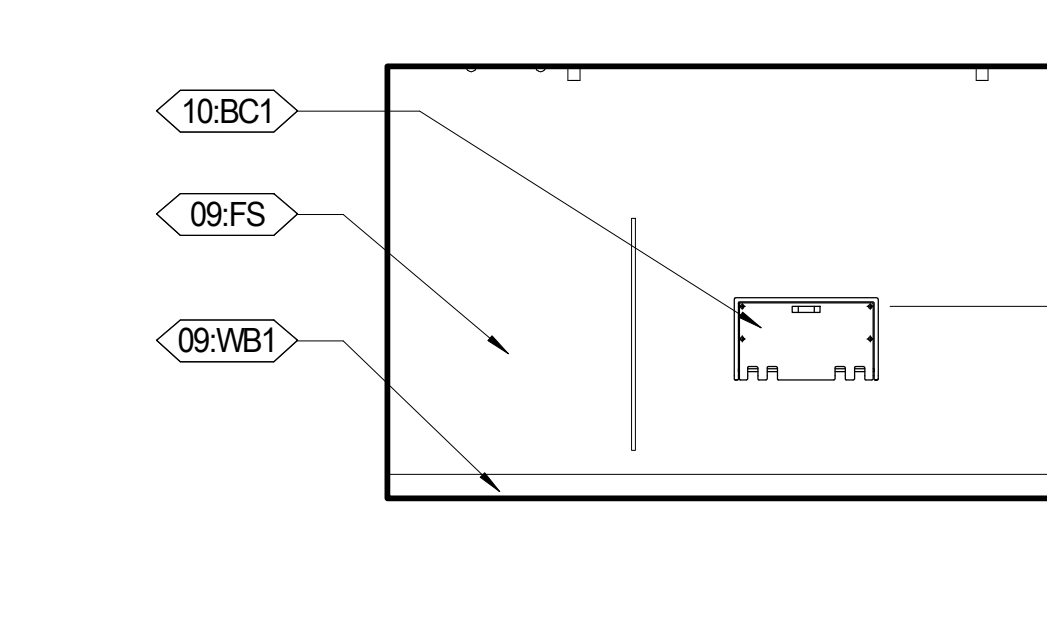

**B4 MEN'S RESTROOM 112 - NORTH**  
A251 1/4" = 1'-0"

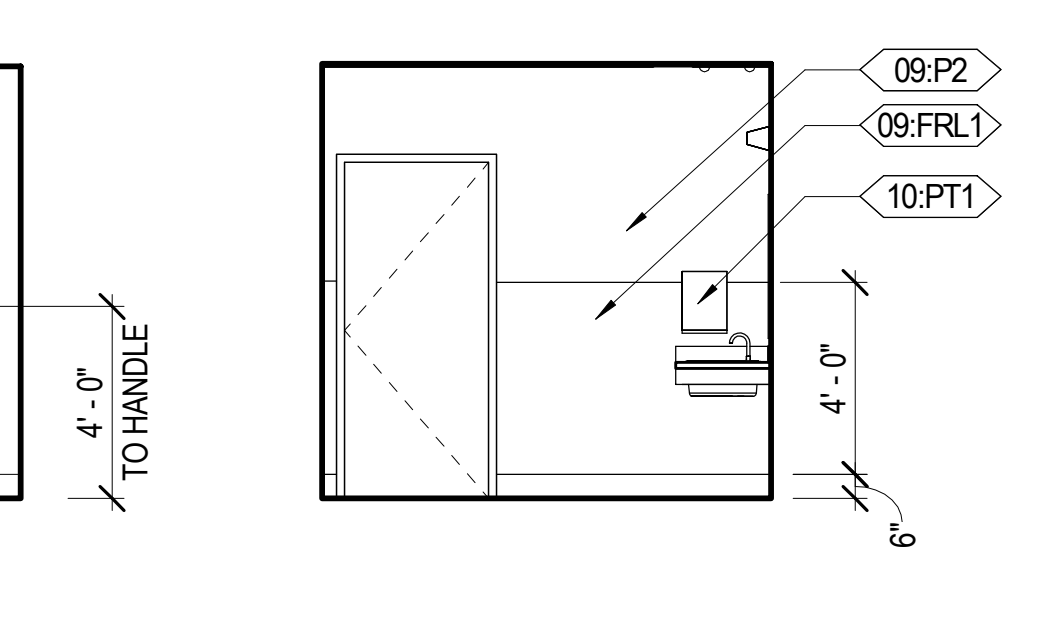

**B5 MEN'S RESTROOM 112 - EAST**  
A251 1/4" = 1'-0"

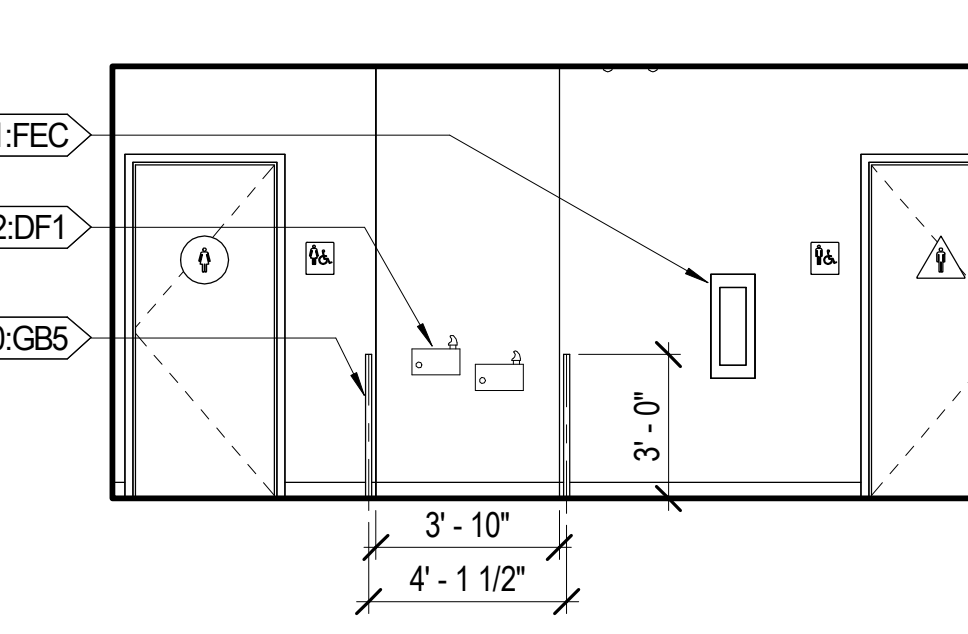

**B6 CORRIDOR 113 - WEST**  
A251 1/4" = 1'-0"

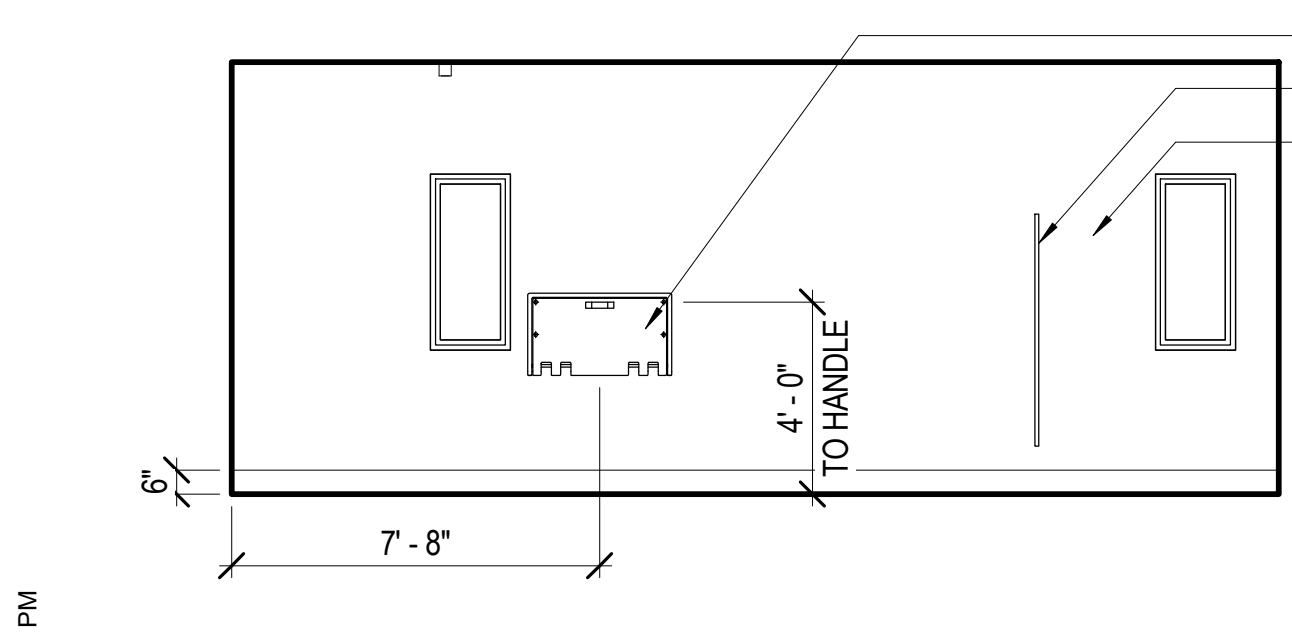

**A1 WOMEN'S RESTROOM 114 - SOUTH**  
A251 1/4" = 1'-0"

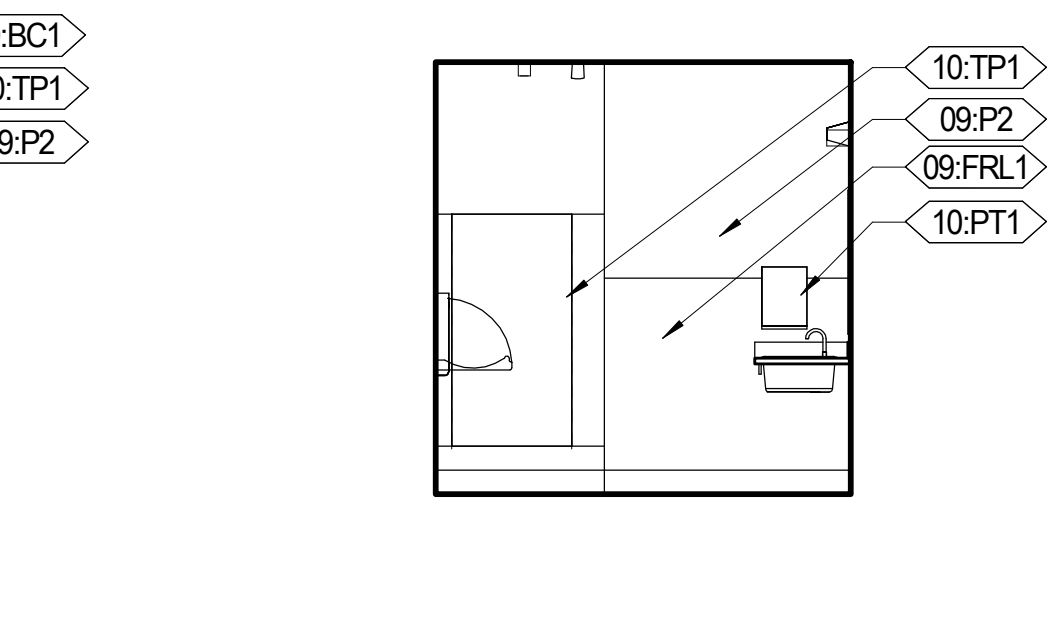

**A2 WOMEN'S RESTROOM 114 - WEST**  
A251 1/4" = 1'-0"

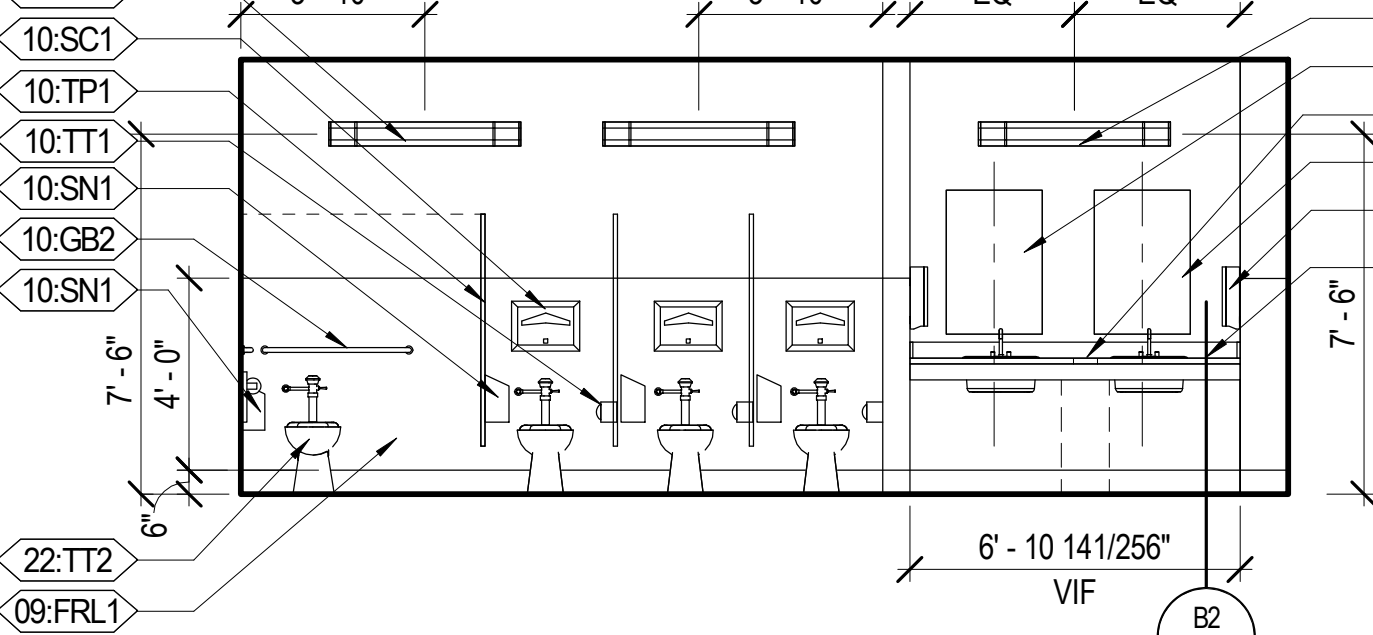

**A3 WOMEN'S RESTROOM 114 - NORTH**  
A251 1/4" = 1'-0"

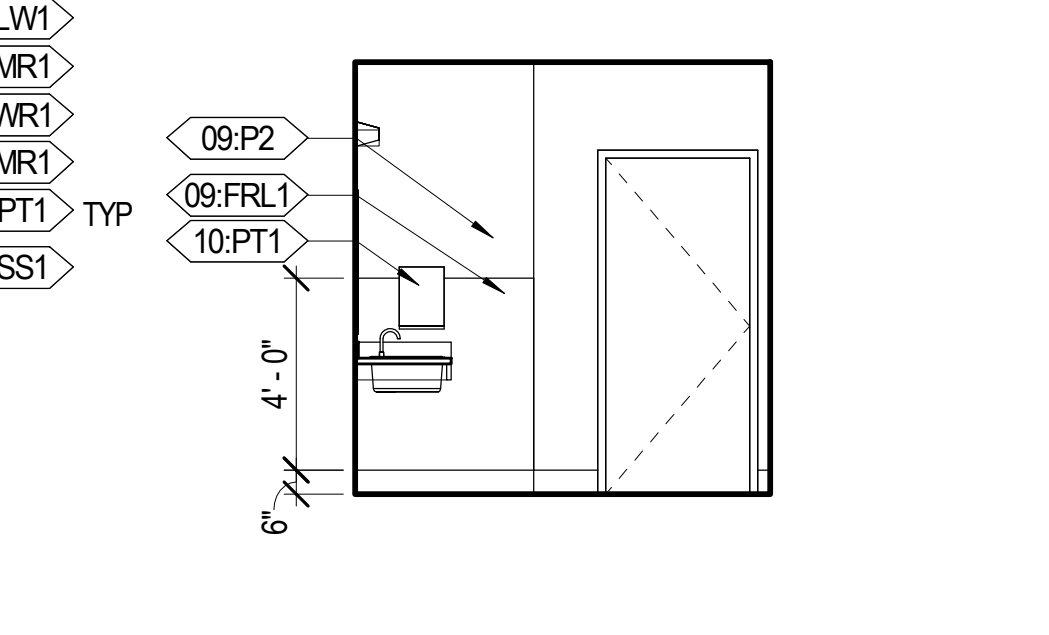

**A4 WOMEN'S RESTROOM 114 - EAST**  
A251 1/4" = 1'-0"

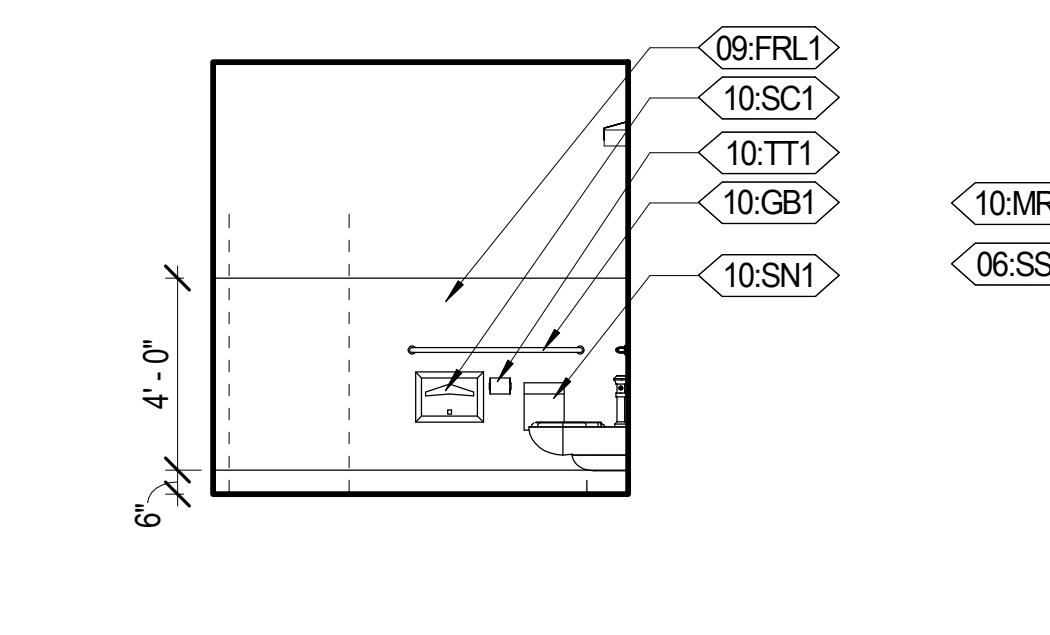

**A5 WOMEN'S RESTROOM 114 - ACC**  
A251 1/4" = 1'-0"

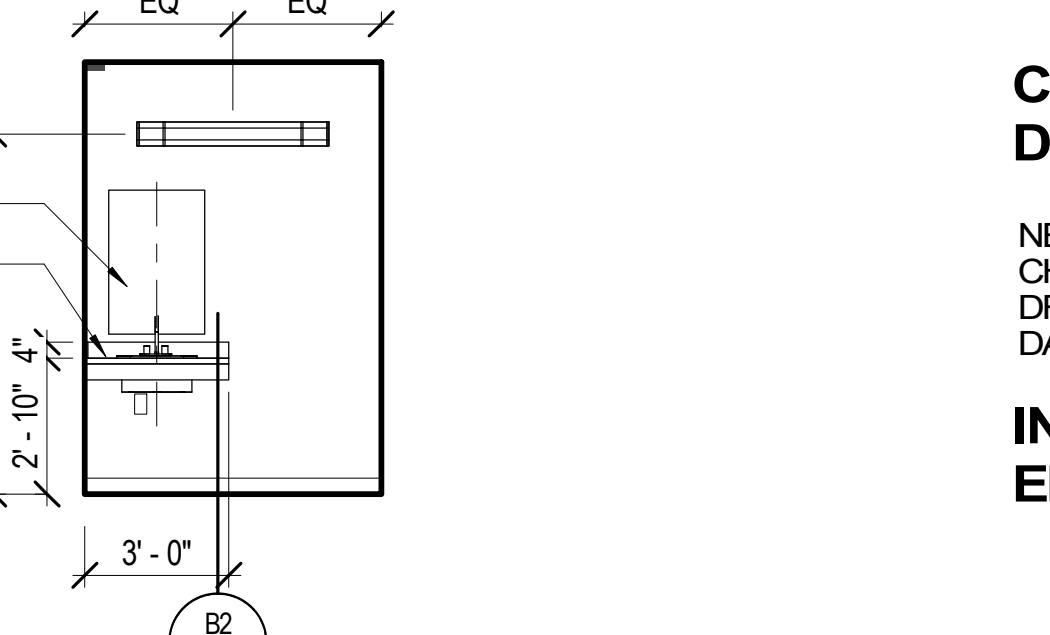

**A6 LACTATION 115 - EAST**  
A251 1/4" = 1'-0"

# Date Revision

### CONSTRUCTION DOCUMENTS

NEXUS PROJ. #: 18117  
CHECKED BY: CJ  
DRAWN BY: RP  
DATE: 01.02.2019

### INTERIOR ELEVATIONS

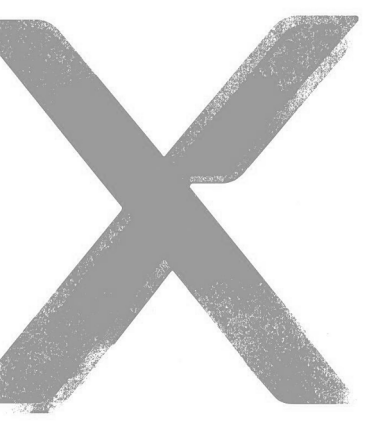

ARCH | NEXUS

Architectural NEXUS, Inc.  
930 R Street  
Sacramento, California 95811  
T 916.443.5911  
http://www.archnexus.com

Original drawings remain the property of the Architect and as such the Architect retains total ownership and control. The design represented by these drawings is sold to the client for a one time use, unless otherwise agreed upon in writing by the Architect. © Architectural Nexus, Inc. 2014



COUNTY OF EL DORADO  
**HHSA TENANT IMPROVEMENT**  
3368 SANDY WAY  
SOUTH LAKE TAHOE, CA 96150

**GENERAL NOTE - INTERIOR ELEVATION**

- A. ENSURE THAT ALL REQUIRED FIXTURE AND CABINET CLEARANCES AND OTHER REQUIREMENTS ARE MAINTAINED PURSUANT TO ADAAG AND ANSI A117.1. SEE SHEET G701 FOR GENERAL GUIDANCE ON COMMON MOUNTING HEIGHTS AND ACCESSIBILITY COMPLIANCE
- B. PROVIDE BLOCKING/BACKING AS NECESSARY FOR MOUNTING OF WALL-MOUNTED CABINETS, FIXTURES AND EQUIPMENT PER MANUFACTURERS RECOMMENDATIONS. COORDINATE THIS REQUIREMENT THROUGH ALL FLOOR PLANS, EQUIPMENT PLANS, AND INTERIOR ELEVATIONS.
- C. ON ALL EXPOSED CABINET SIDES, INCLUDING KNEE OPENINGS, PROVIDE FINISHED FACE TO MATCH CABINET FRONTS. PROVIDE SIDESPLASHES WHENEVER COUNTERTOPS ARE ADJACENT TO WALLS.

KEYNOTE LEGEND	
Key Value	Keynote Text
06:PL1	PLASTIC LAMINATE
06:PL2	PLASTIC LAMINATE
06:SS1	SOLID SURFACE
06:WB1	CONT. WOOD BACKER STRIP
09:FP1	PAINTED FINISH; SEE FINISH LEGEND
09:FRL1	FIBER REINFORCED LAMINATE, FRL1 SEE FINISH LEGEND
09:P2	SEMI-GLOSS PAINT, P2 SEE FINISH LEGEND
09:WB1	SCHEDULED WALL BASE; SEE FINISH SCHEDULE
10:GB1	42" GRAB BAR
10:GB2	36" GRAB BAR
10:MR1	MIRROR (24"X36")
10:PT1	PAPER TOWEL DISPENSER
10:SC1	TOILET SEAT COVER DISPENSER
10:SN1	SANITARY NAPKIN DISPOSAL UNIT
10:TT1	TOILET TISSUE DISPENSER
11:AV1	AUDIO-VISUAL EQUIPMENT
22:WS1	WALL MOUNT SINK
26:LW1	WALL MOUNTED LIGHT FIXTURE; SEE ELECTRICAL
26:TV2	MEDIA CENTER W/ WALL MOUNT 65" LCD FLATSCREEN, SMARTBOARD & CAMERA, OFOI, CONTRACTOR TO PROVIDE BACKING

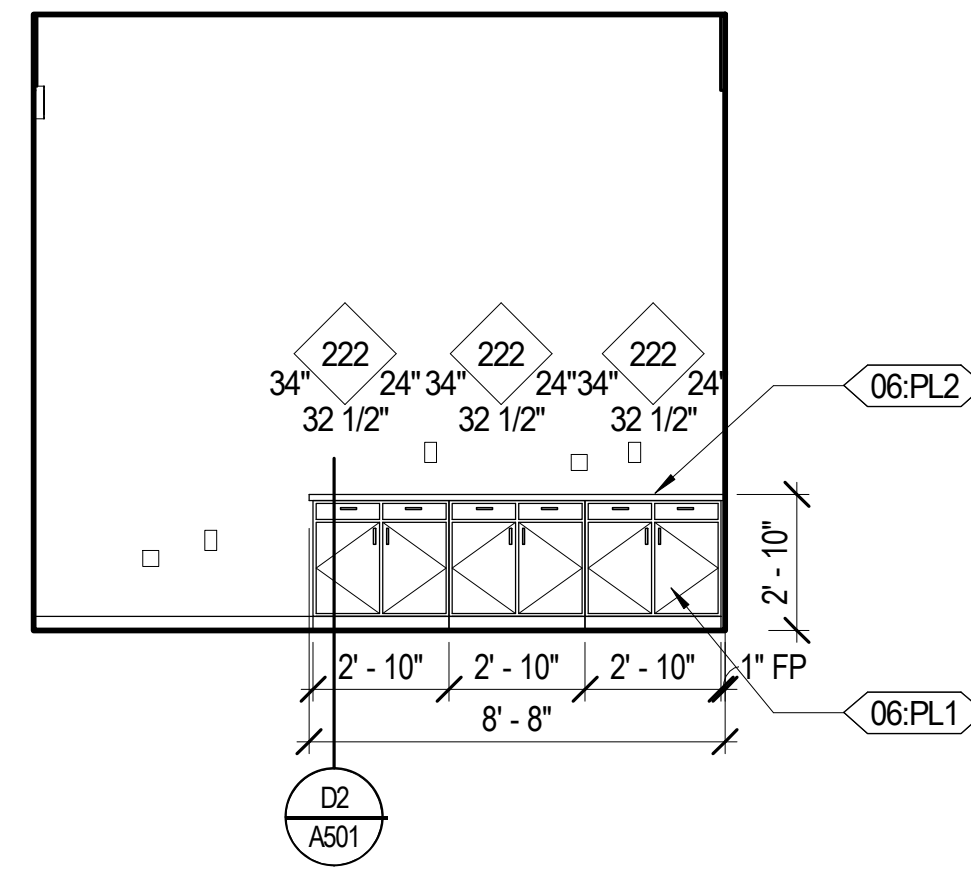

**E5 WORK/MAIL 122 - NORTH**  
A252 1/4" = 1'-0"

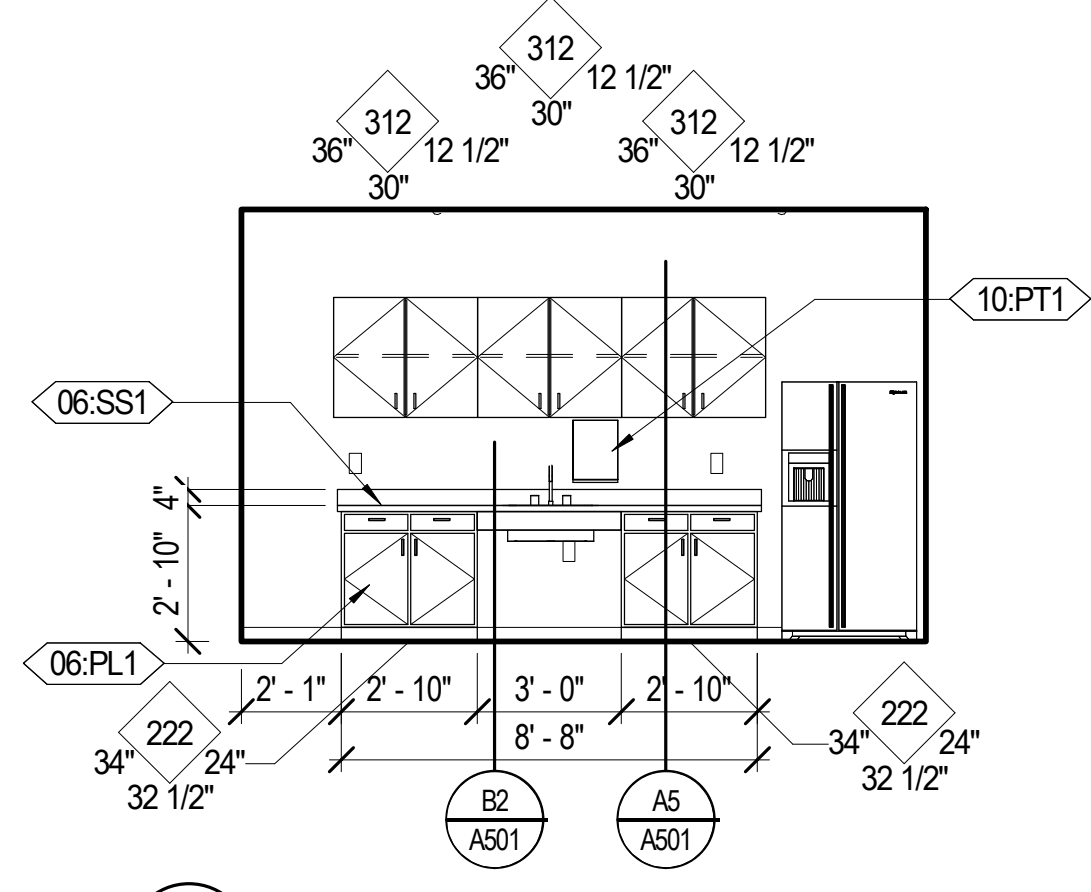

**E4 BREAK ROOM 117 - WEST**  
A252 1/4" = 1'-0"

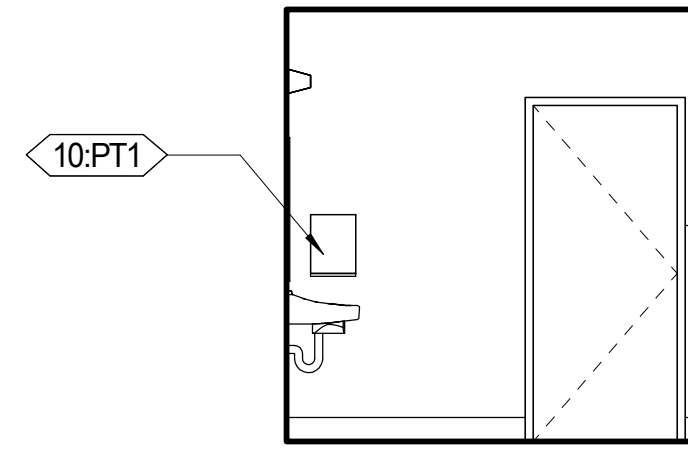

**E3 UNISEX STAFF RESTROOM 116 - NORTH**  
A252 1/4" = 1'-0"

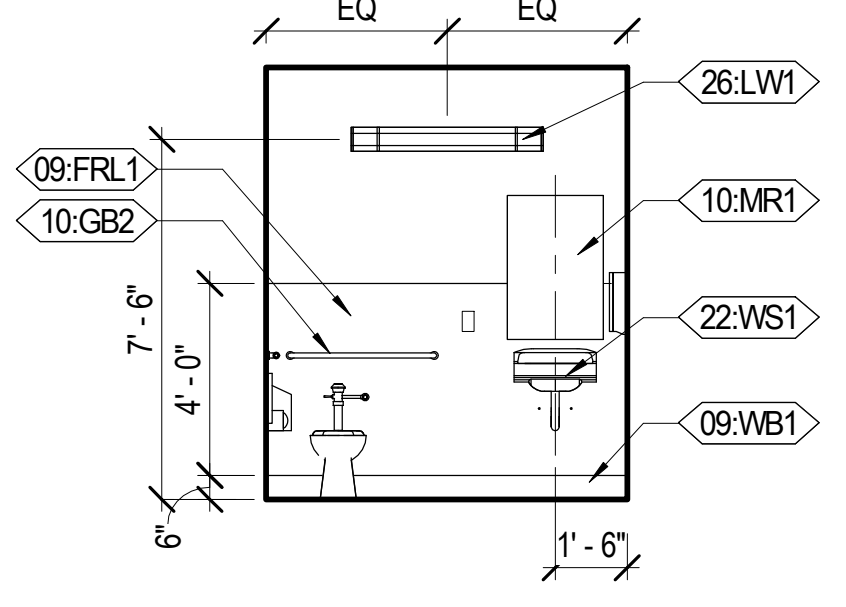

**E2 UNISEX STAFF RESTROOM 116 - WEST**  
A252 1/4" = 1'-0"

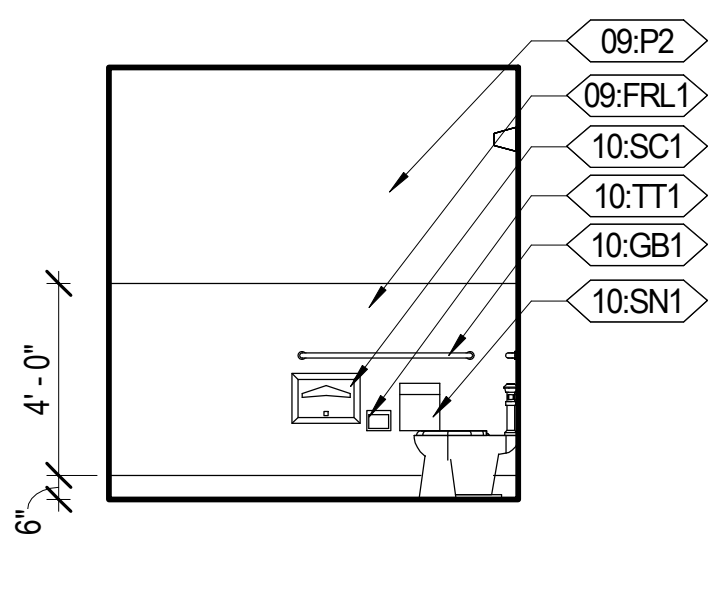

**E1 UNISEX STAFF RESTROOM 116 - SOUTH**  
A252 1/4" = 1'-0"

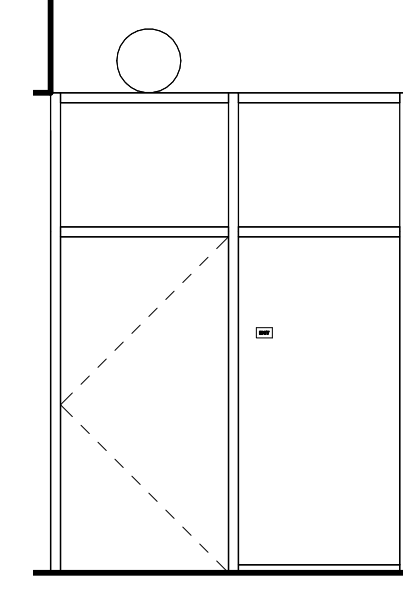

**D2 WAITING 103**  
A252 1/4" = 1'-0"

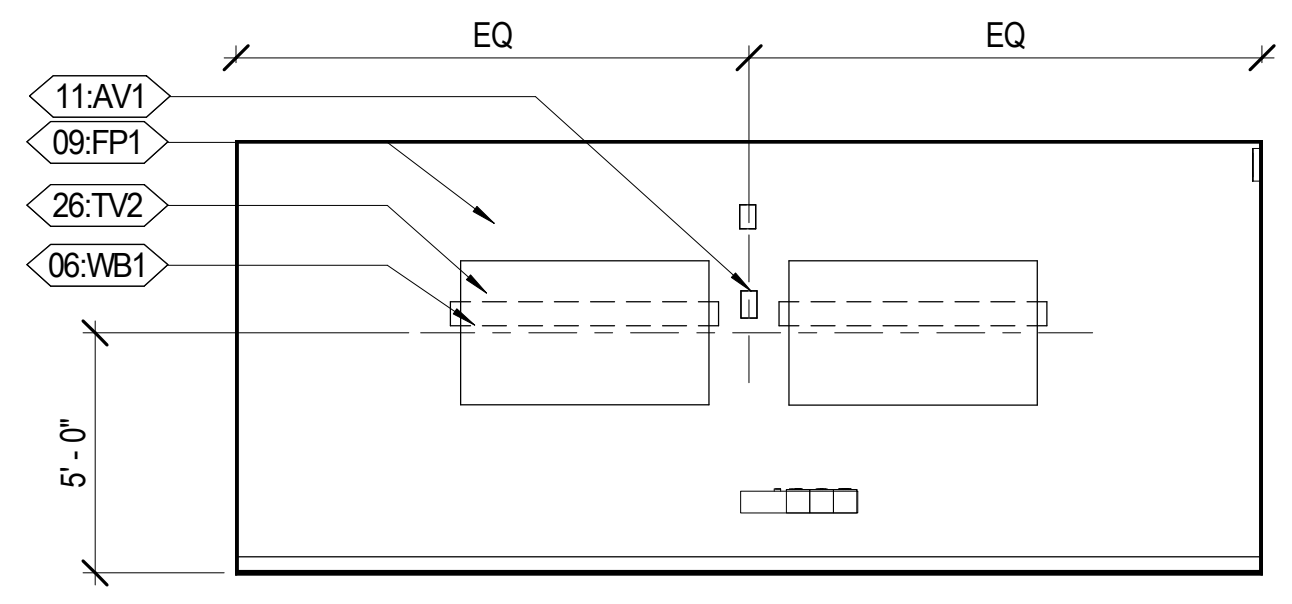

**D1 LARGE MEETING ROOM 123 SOUTH**  
A252 1/4" = 1'-0"

# Date Revision

**CONSTRUCTION DOCUMENTS**

NEXUS PROJ. #: 18117  
CHECKED BY: RP  
DRAWN BY: CJ  
DATE: 01.02.2019

**INTERIOR ELEVATIONS**



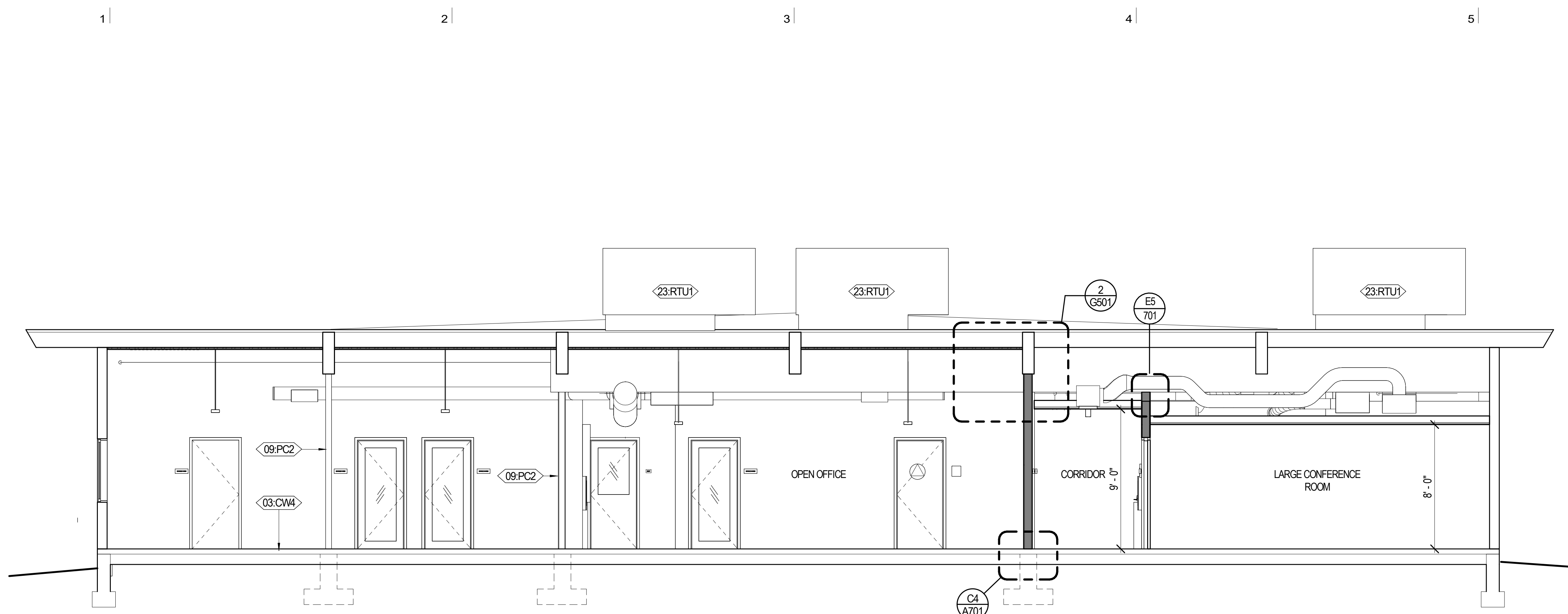

**D1 BUILDING SECTION A**  
A301 1/4" = 1'-0"

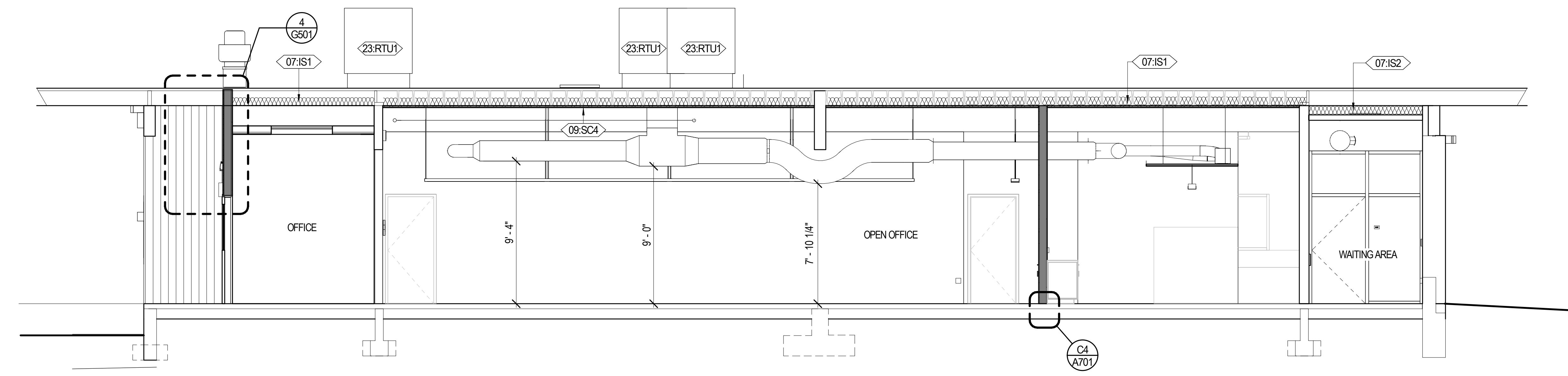

**B1 BUILDING SECTION B**  
A301 1/4" = 1'-0"

**GENERAL NOTE - SECTION**

- A. WALL DIMENSIONS ARE TO GRID LINE OR FACE OF WALL STRUCTURE. "CLEAR" DIMENSIONS ARE TO FACE OF WALL FINISH.
- B. SEE CIVIL, STRUCTURAL, MECHANICAL AND ELECTRICAL DRAWINGS FOR MORE INFORMATION.
- C. SEE G SERIES SHEETS FOR WALL TYPES AND TYPICAL ACCESSIBILITY CLEARANCE AND COMPLIANCE REQUIREMENTS.
- D. DO NOT SCALE DRAWINGS.

KEYNOTE LEGEND	
Key Value	Keynote Text
03: CW4	PATCH & REPAIR (E) CONC SLAB AS REQUIRED FOR NEW WORK. SEE DETAIL D1/A501
07: IS1	R-38 BATT INSULATION. INSTALL BETWEEN ROOF JOISTS, TYP
07: IS2	R-38 BATT INSULATION TO BE INSTALLED AT EXISTING CEILING IN WAITING
09: PC2	PAINT (E) EXPOSED COLUMN
09: SC4	WHITE POLYPROPYLENE SCRIM.
23: RTU1	REPLACE (E) ROOF TOP UNIT ON (E) CURB. PROTECT (E) OPENING FOR REUSE. SEE MECHANICAL FOR MORE INFORMATION



ARCH | NEXUS  
Architectural NEXUS, Inc.  
930 R Street  
Sacramento, California 95811  
T 916.443.5911  
http://www.archnexus.com

Original drawings remain the property of the Architect and as such the Architect retains total ownership and control. The design represented by these drawings is sold to the client for a one time use, unless otherwise agreed upon in writing by the Architect.  
© Architectural Nexus, Inc. 2014



COUNTY OF EL DORADO  
**HHSA TENANT IMPROVEMENT**  
3368 SANDY WAY  
SOUTH LAKE TAHOE, CA 96150

#	Date	Revision

**CONSTRUCTION DOCUMENTS**

NEXUS PROJ. #: 18117  
CHECKED BY: RP  
DRAWN BY: MR  
DATE: 01.02.2019

**BUILDING SECTIONS**

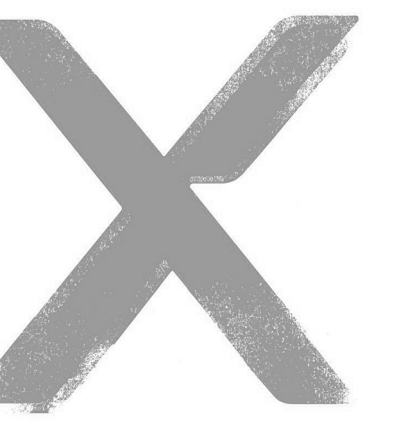

ARCH | NEXUS

Architectural NEXUS, Inc.  
930 R Street  
Sacramento, California 95811  
T 916.443.5911  
http://www.archnexus.com

Original drawings remain the property of the Architect and as such the Architect retains total ownership and control. The design represented by these drawings is sold to the client for a one time use, unless otherwise agreed upon in writing by the Architect. © Architectural Nexus, Inc. 2014



COUNTY OF EL DORADO  
**HHSA TENANT IMPROVEMENT**  
3368 SANDY WAY  
SOUTH LAKE TAHOE, CA 96150

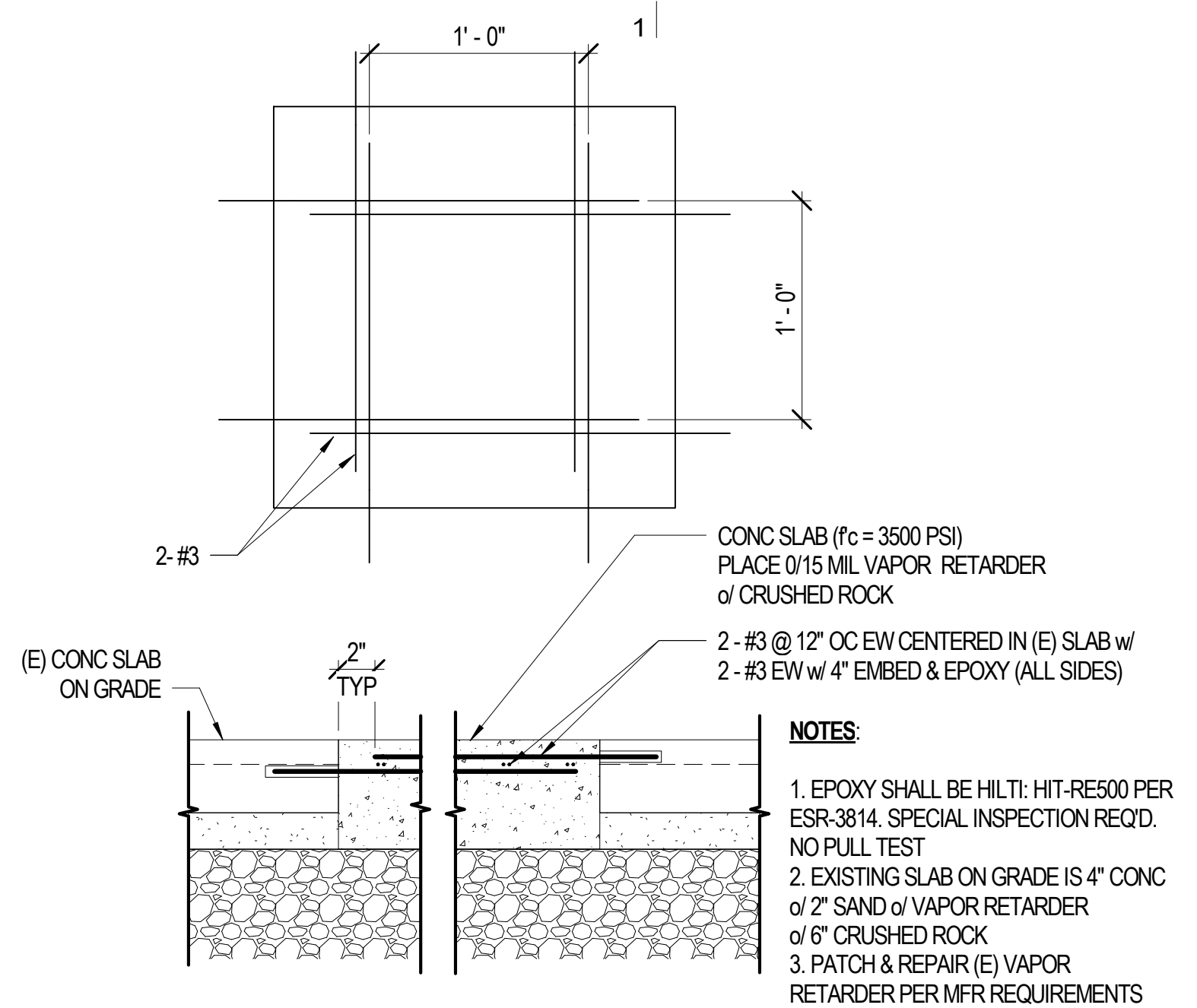

**D1 (E) SLAB REPAIR**  
A501 1 1/2" = 1'-0"

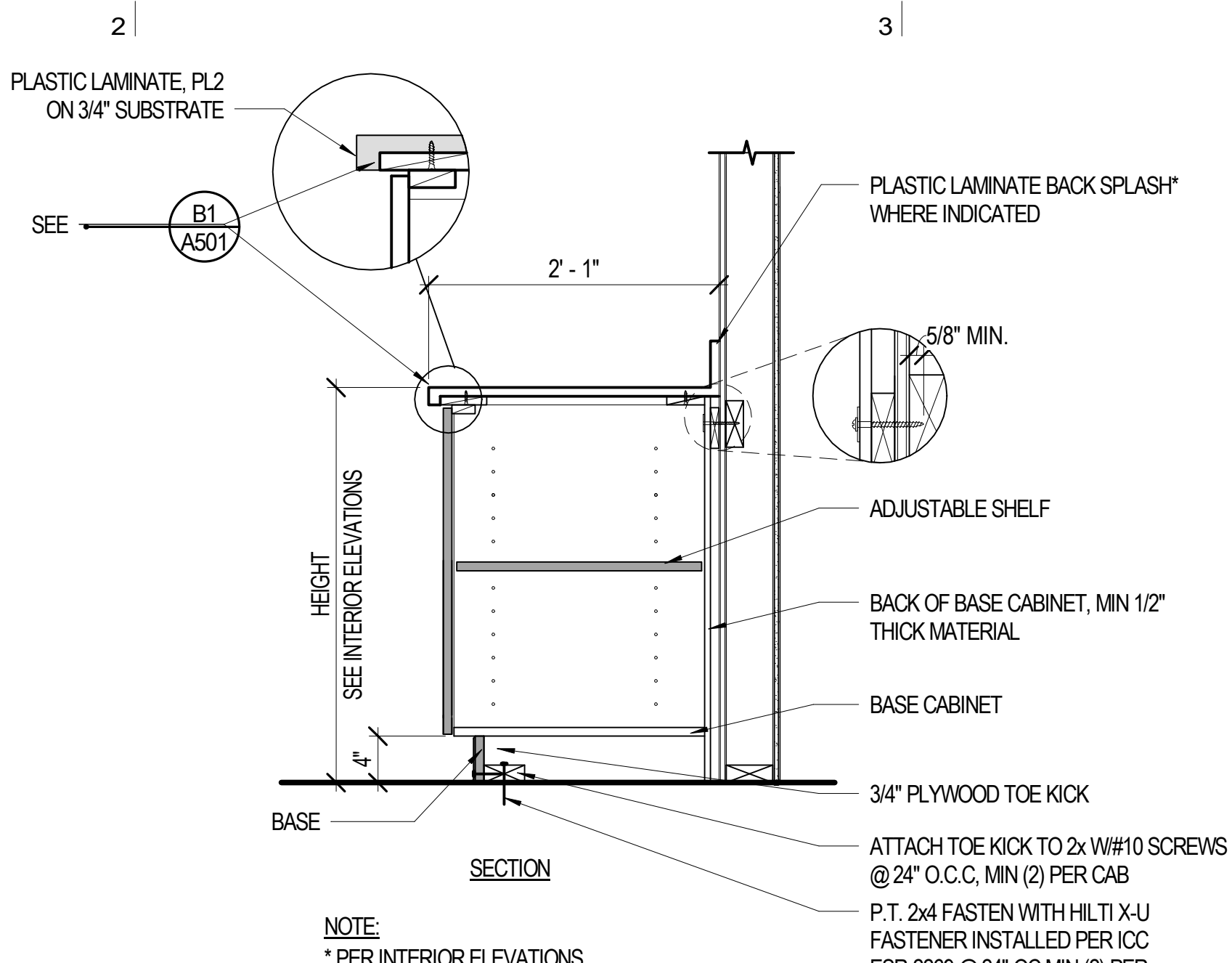

**D2 BASE CAB DOORS**  
A501 1" = 1'-0"

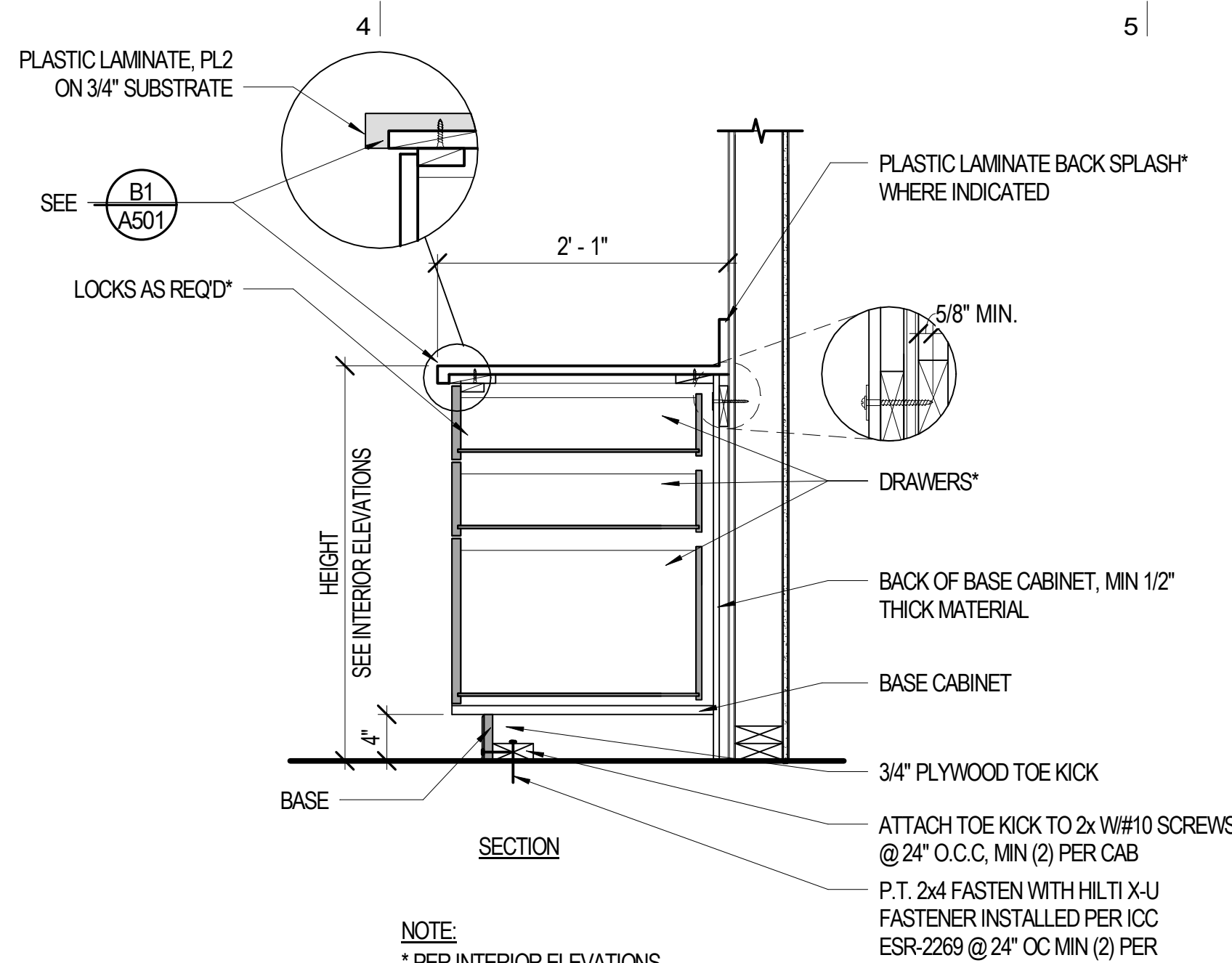

**D3 BASE CABINETS - DRAWERS**  
A501 1" = 1'-0"

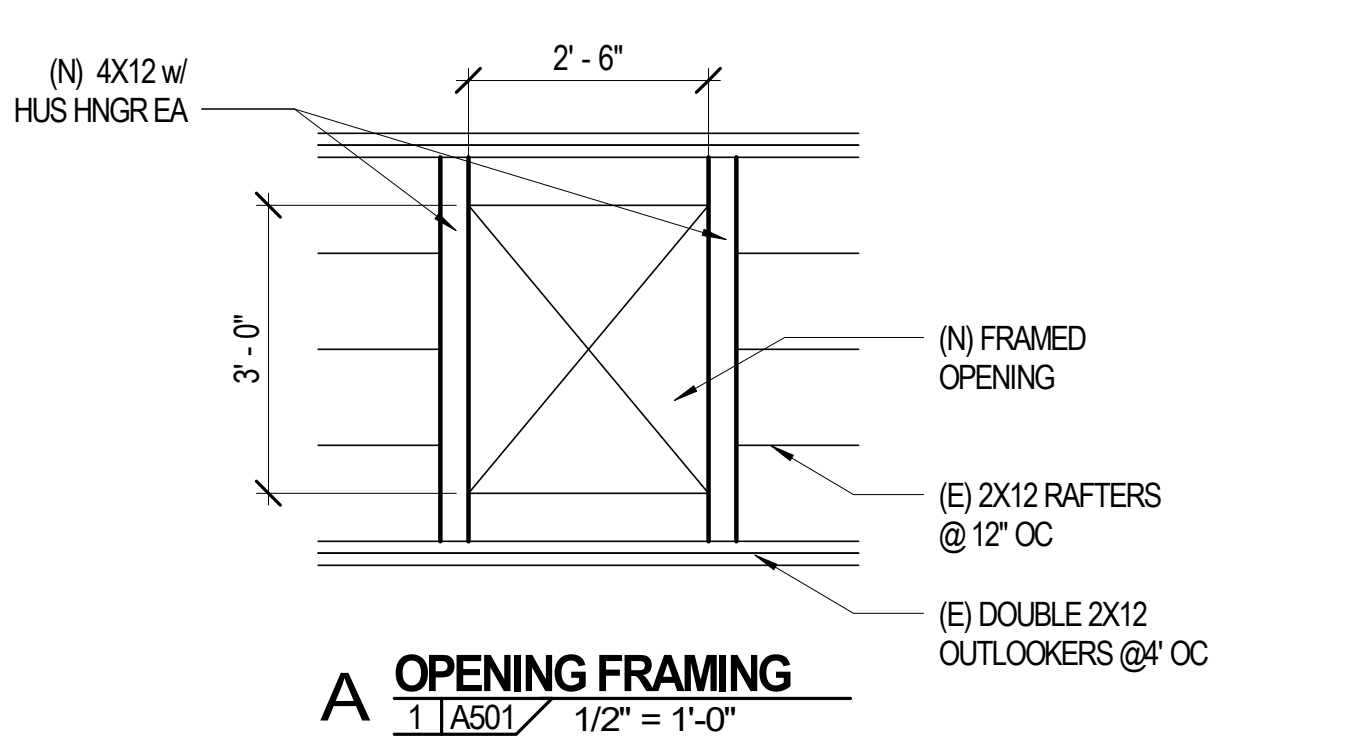
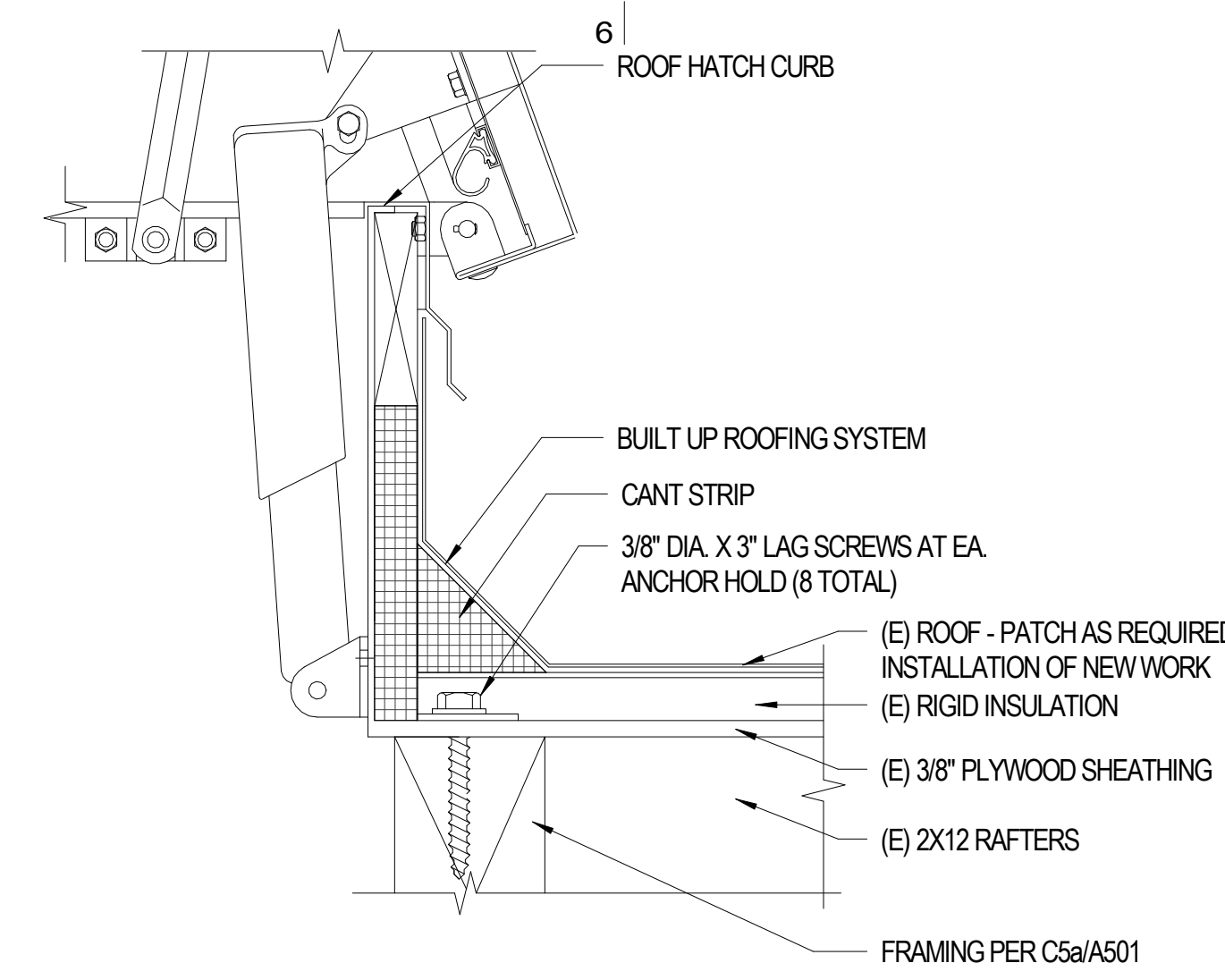

**C4 ROOF HATCH**  
A501 3" = 1'-0"

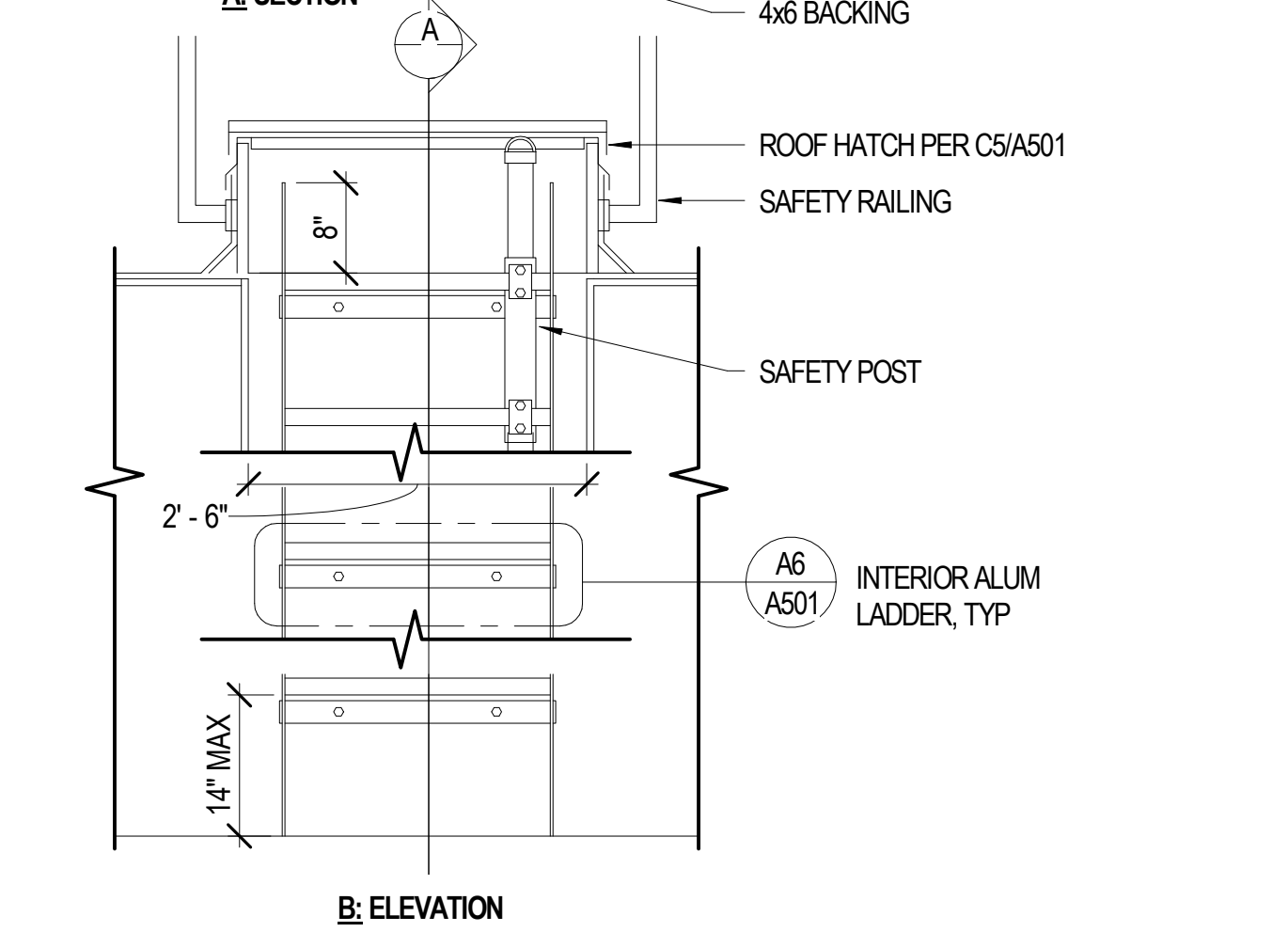
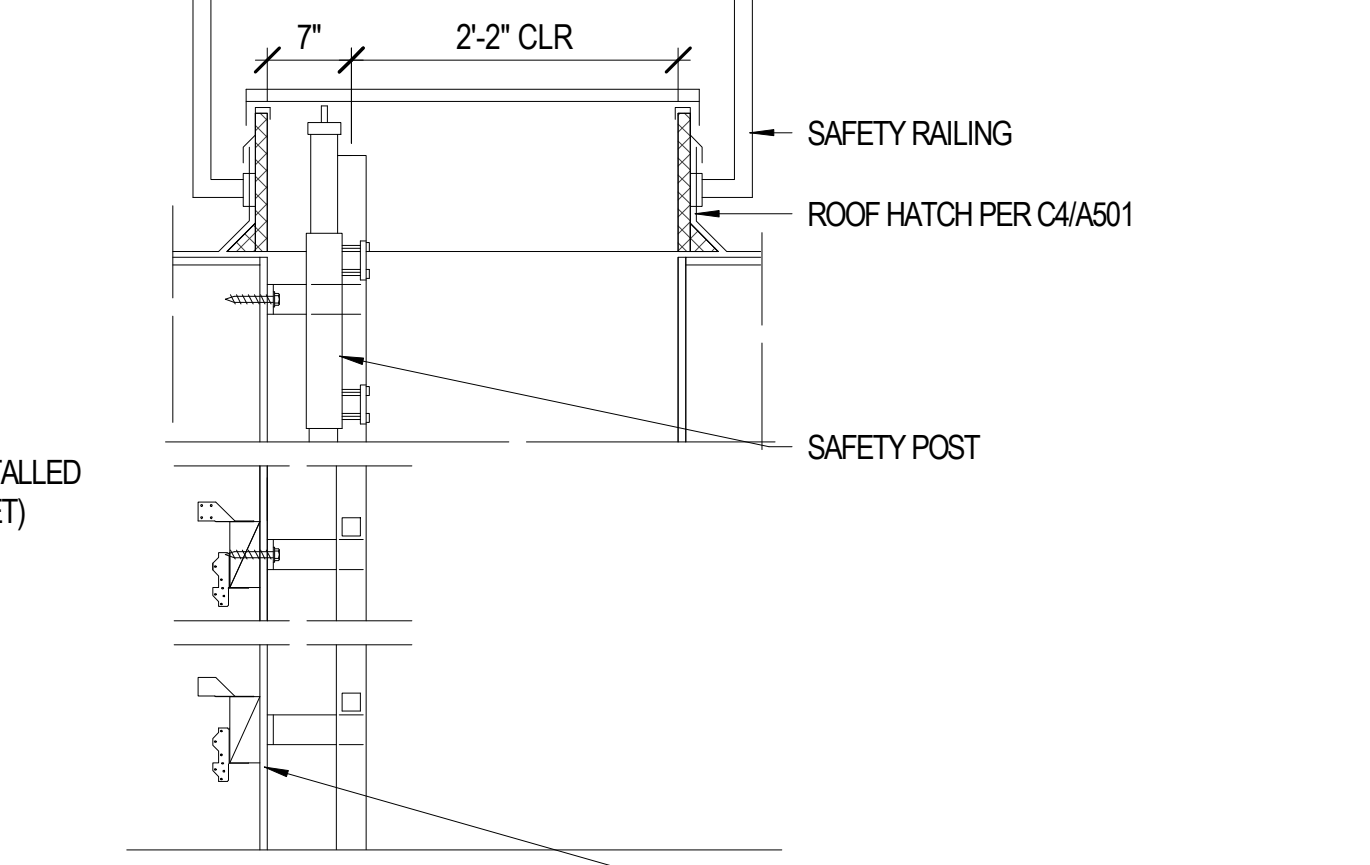

**B3 ROOF HATCH LADDER**  
A501 3/4" = 1'-0"

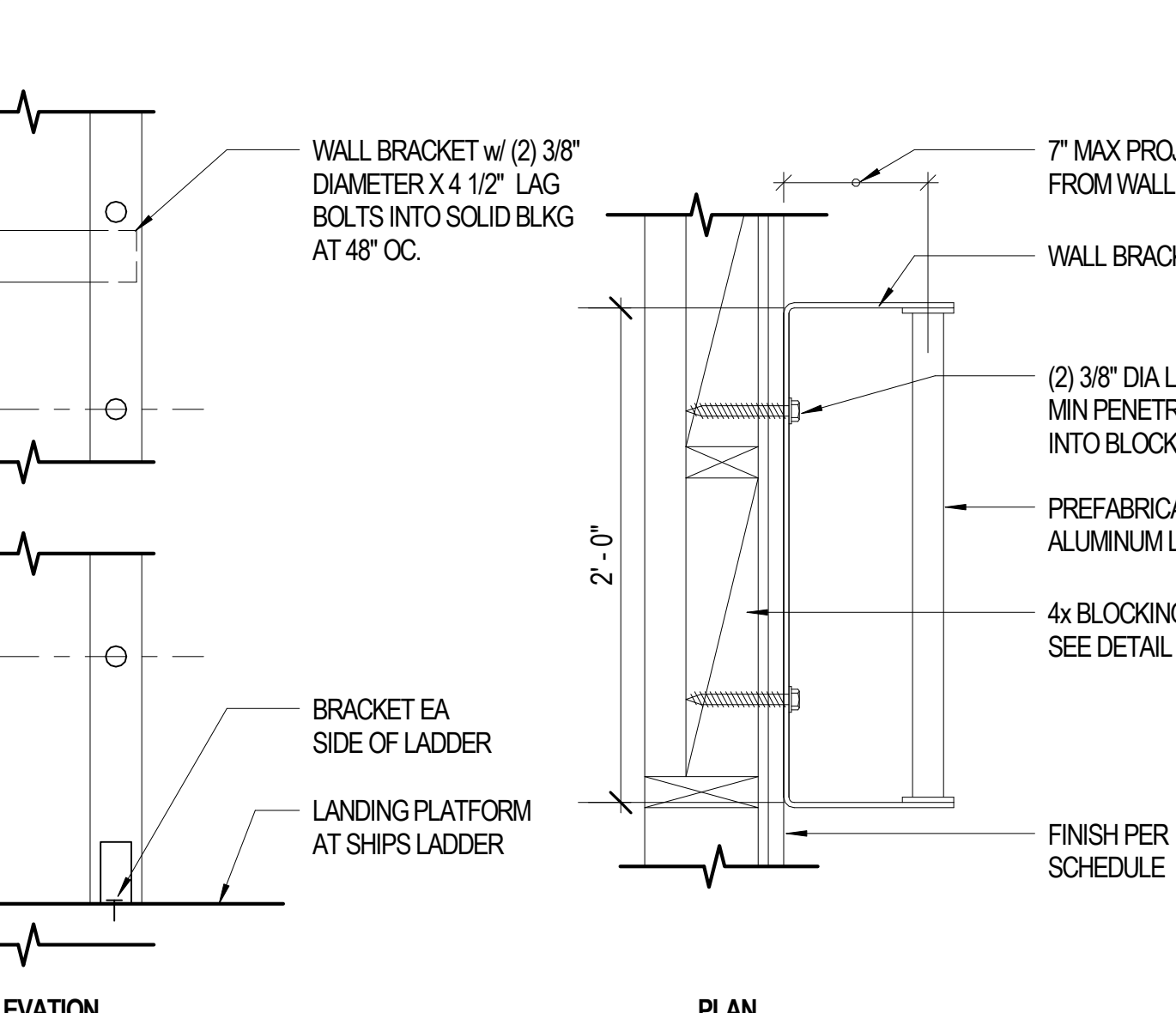

**A6 INTERIOR ALUM LADDER**  
A501 1 1/2" = 1'-0"

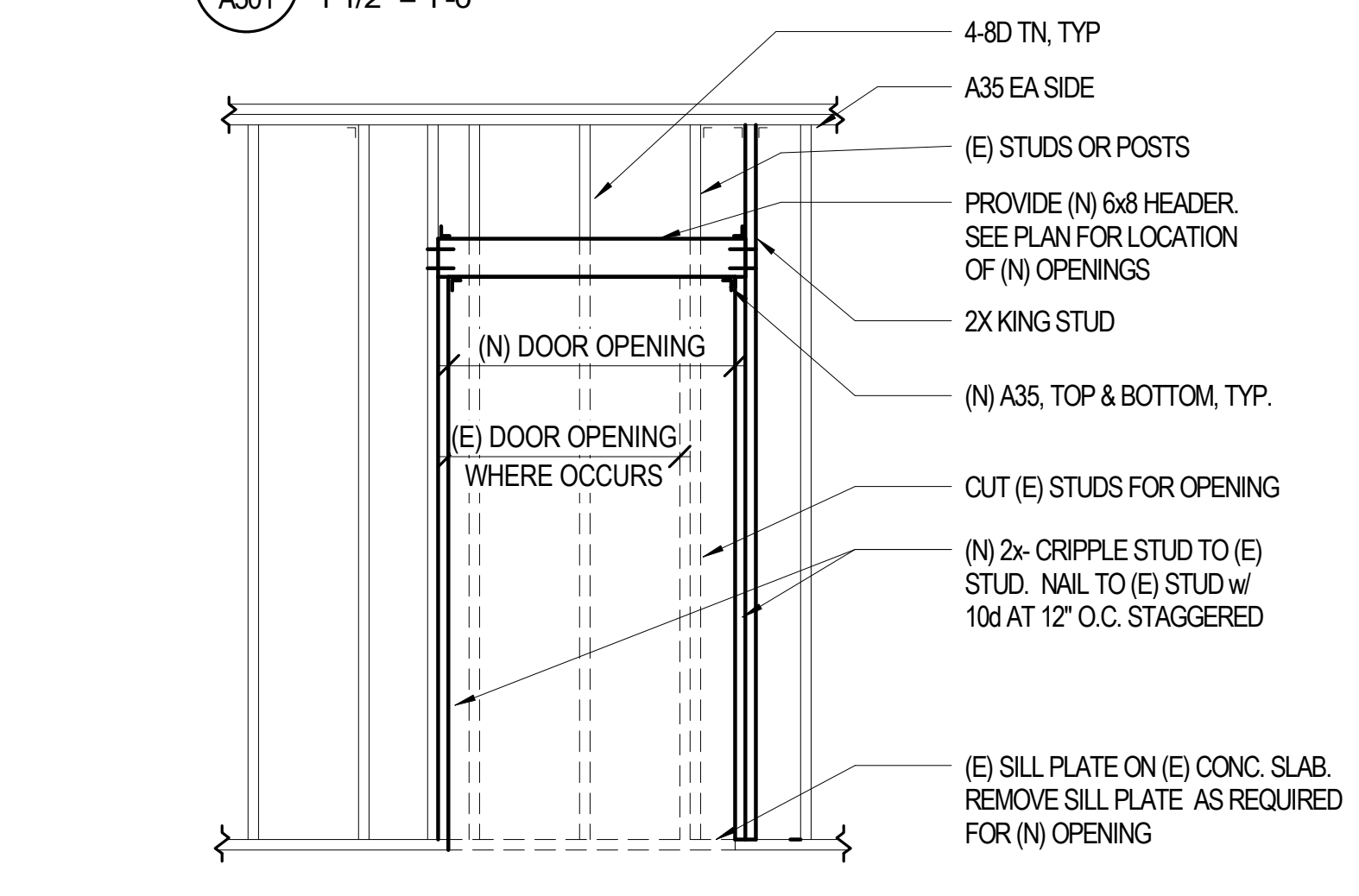

**C1 TYPICAL NEW FRAMED WALL OPENING**  
A501 1/2" = 1'-0"

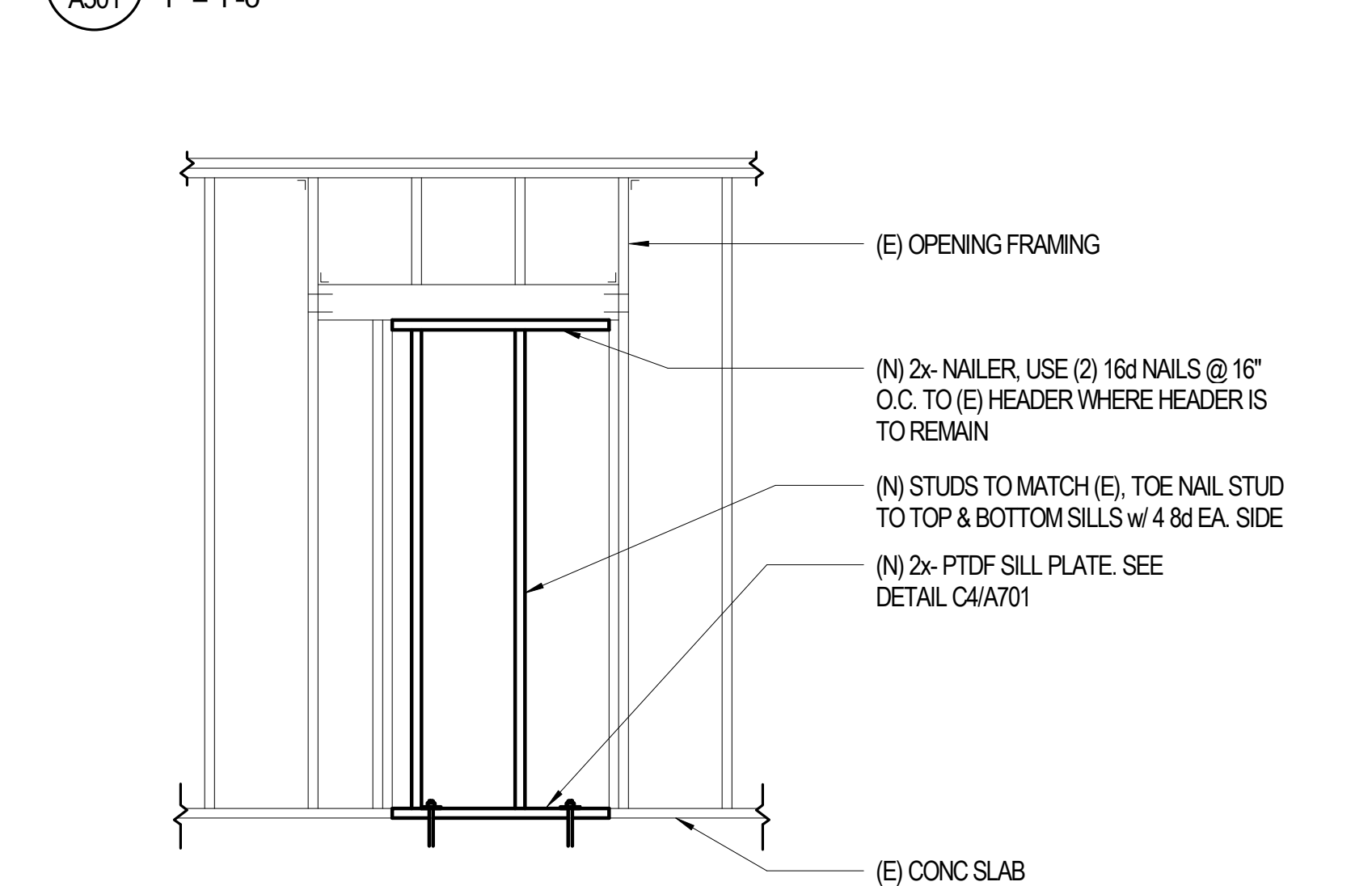

**C2 TYPICAL INFILL FRAMING**  
A501 1/2" = 1'-0"

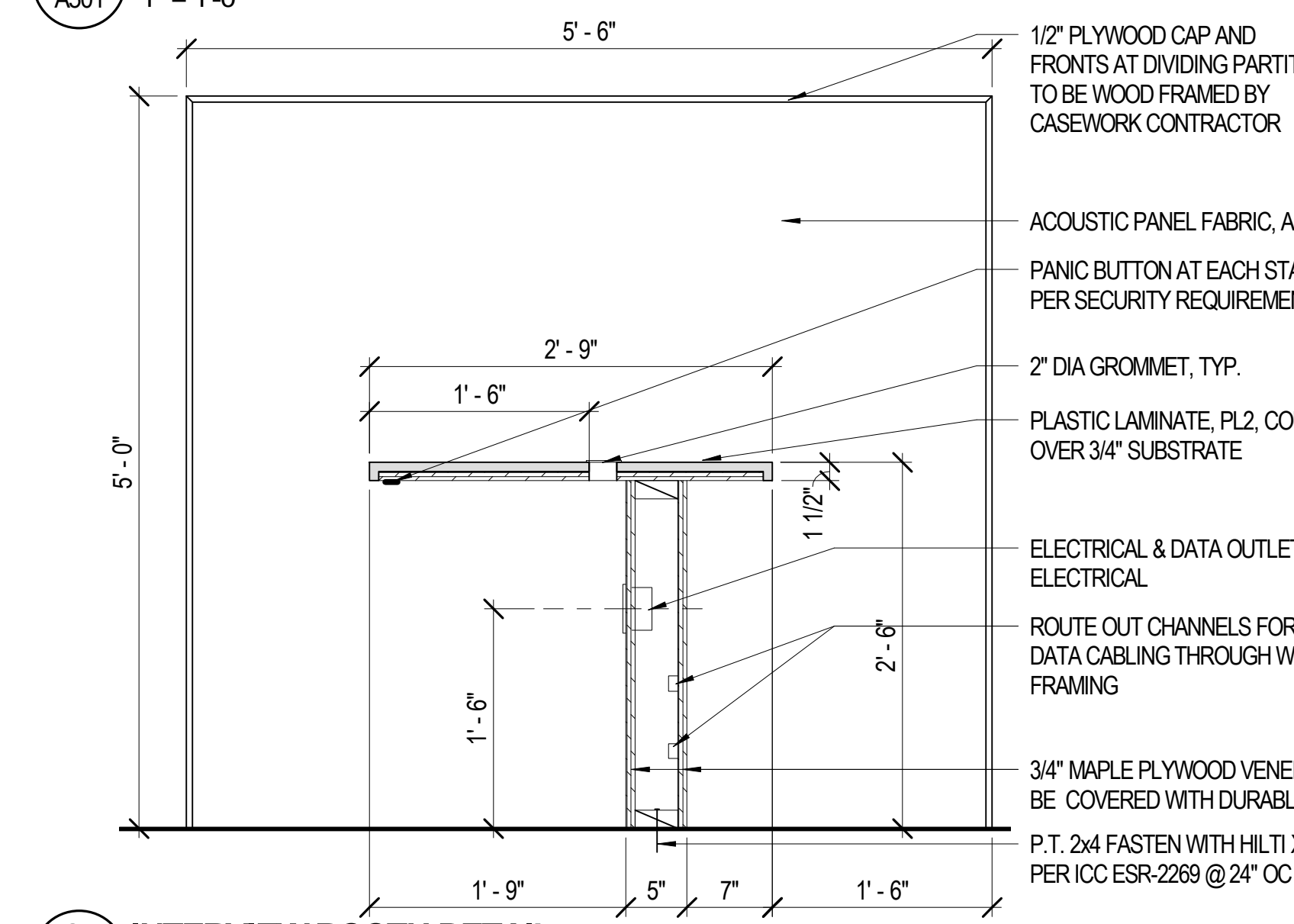

**C3 INTERVIEW BOOTH DETAIL**  
A501 1" = 1'-0"

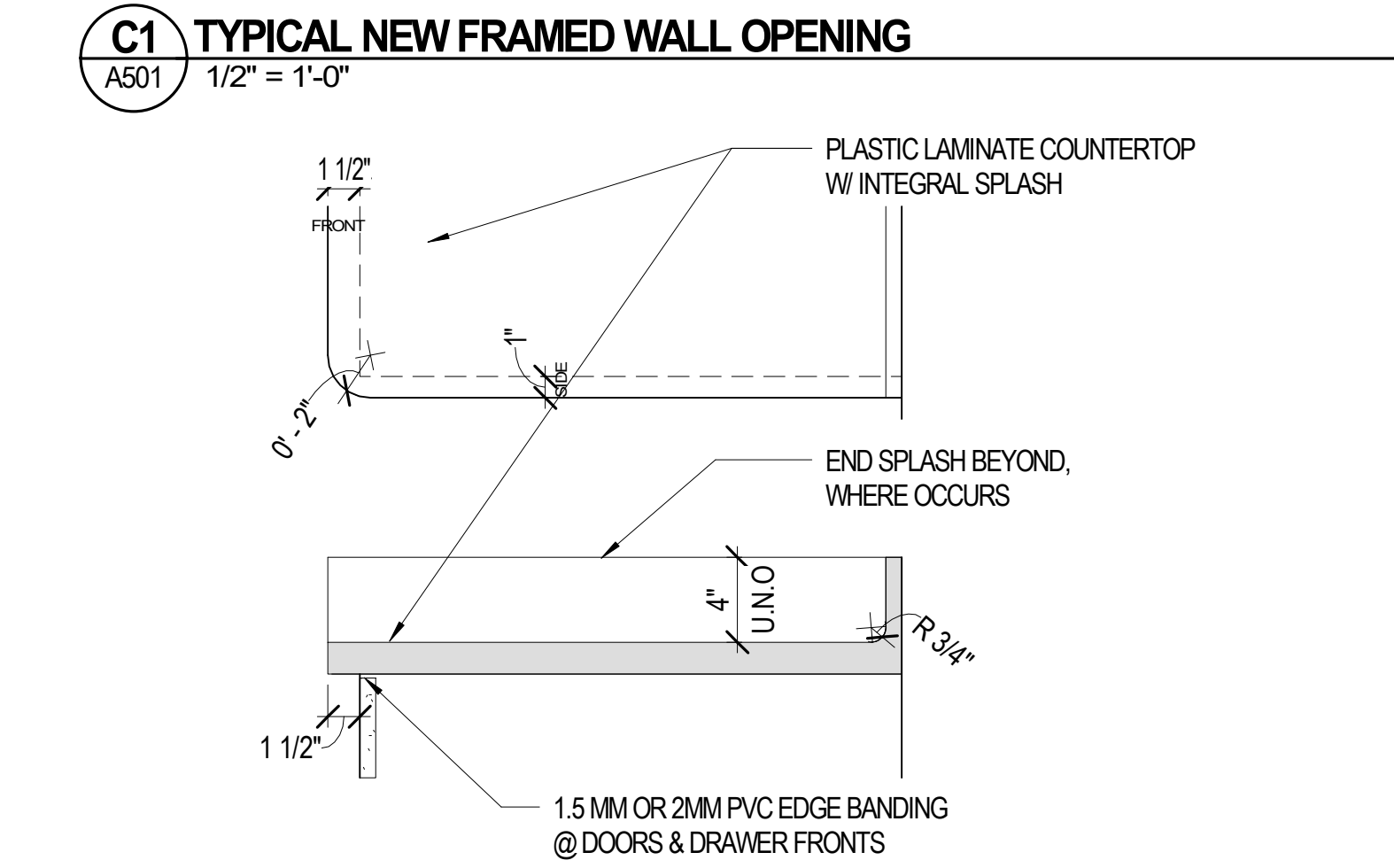

**B1 TYPICAL CASEWORK COUNTERTOP DETAILS**  
A501 1 1/2" = 1'-0"

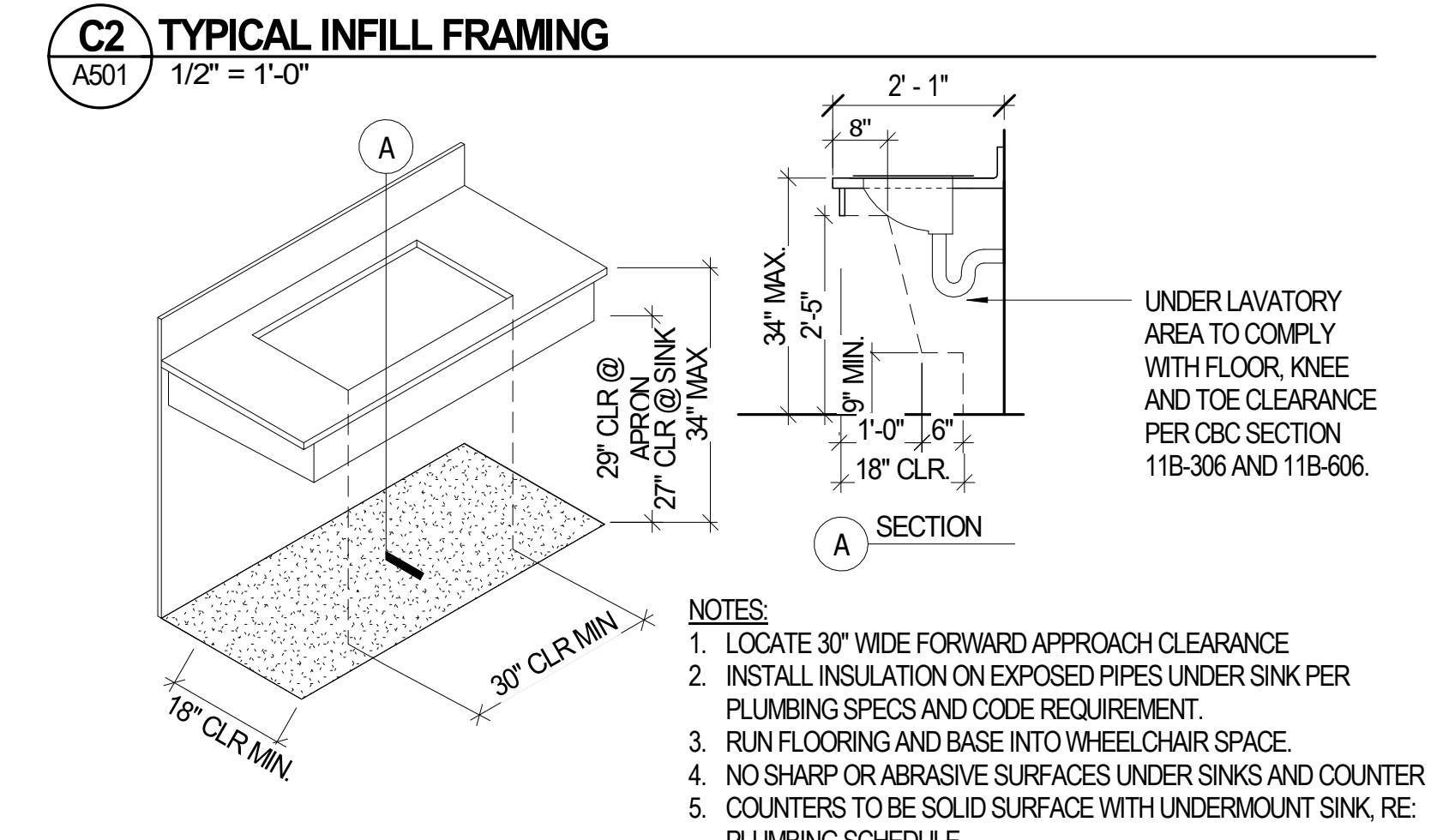

**B2 TYPICAL ACCESSIBLE SINK COUNTER CLEARANCES**  
A501 1/2" = 1'-0"

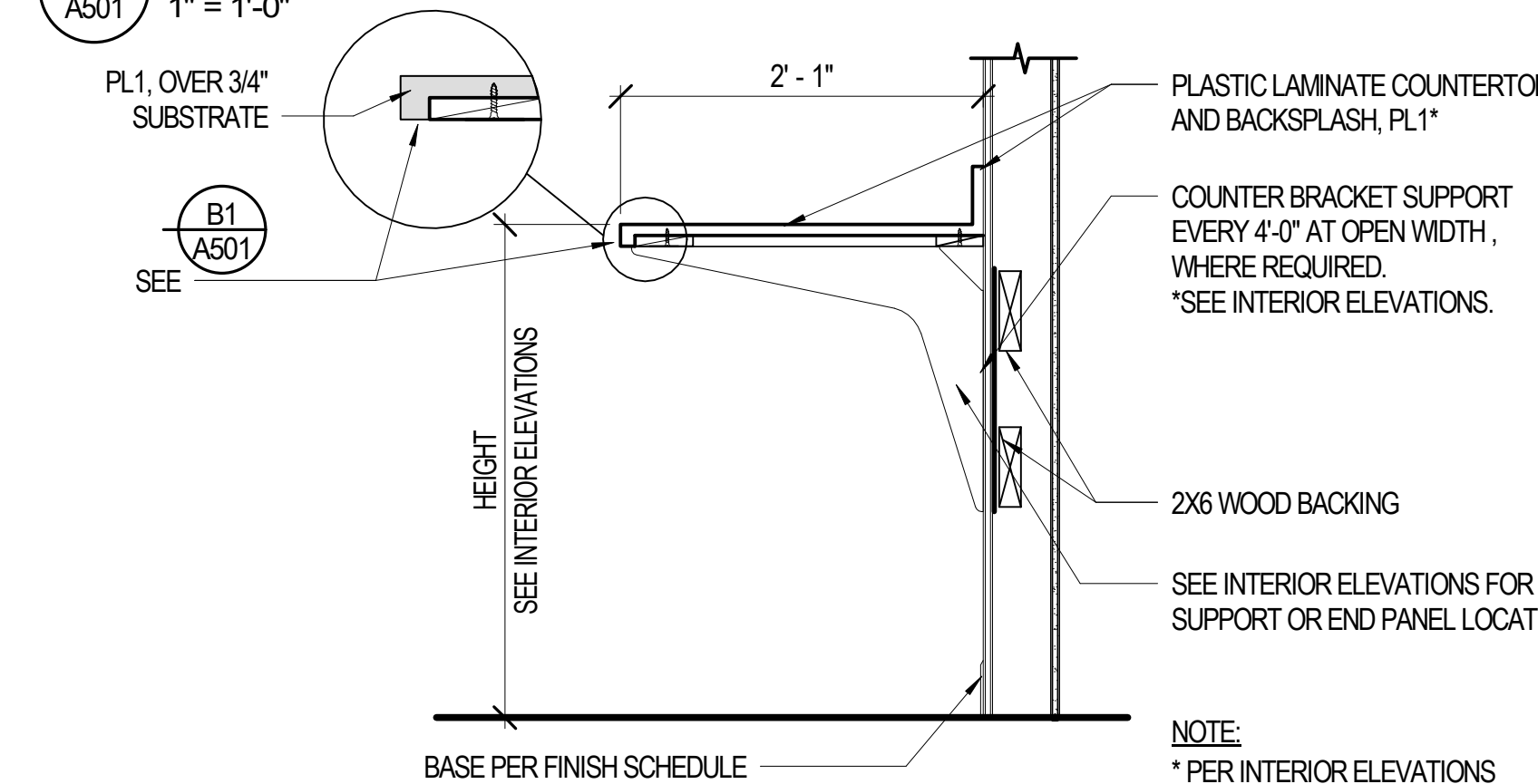

**2 OPEN COUNTERTOP WITH SUPPORT**  
A501 1" = 1'-0"

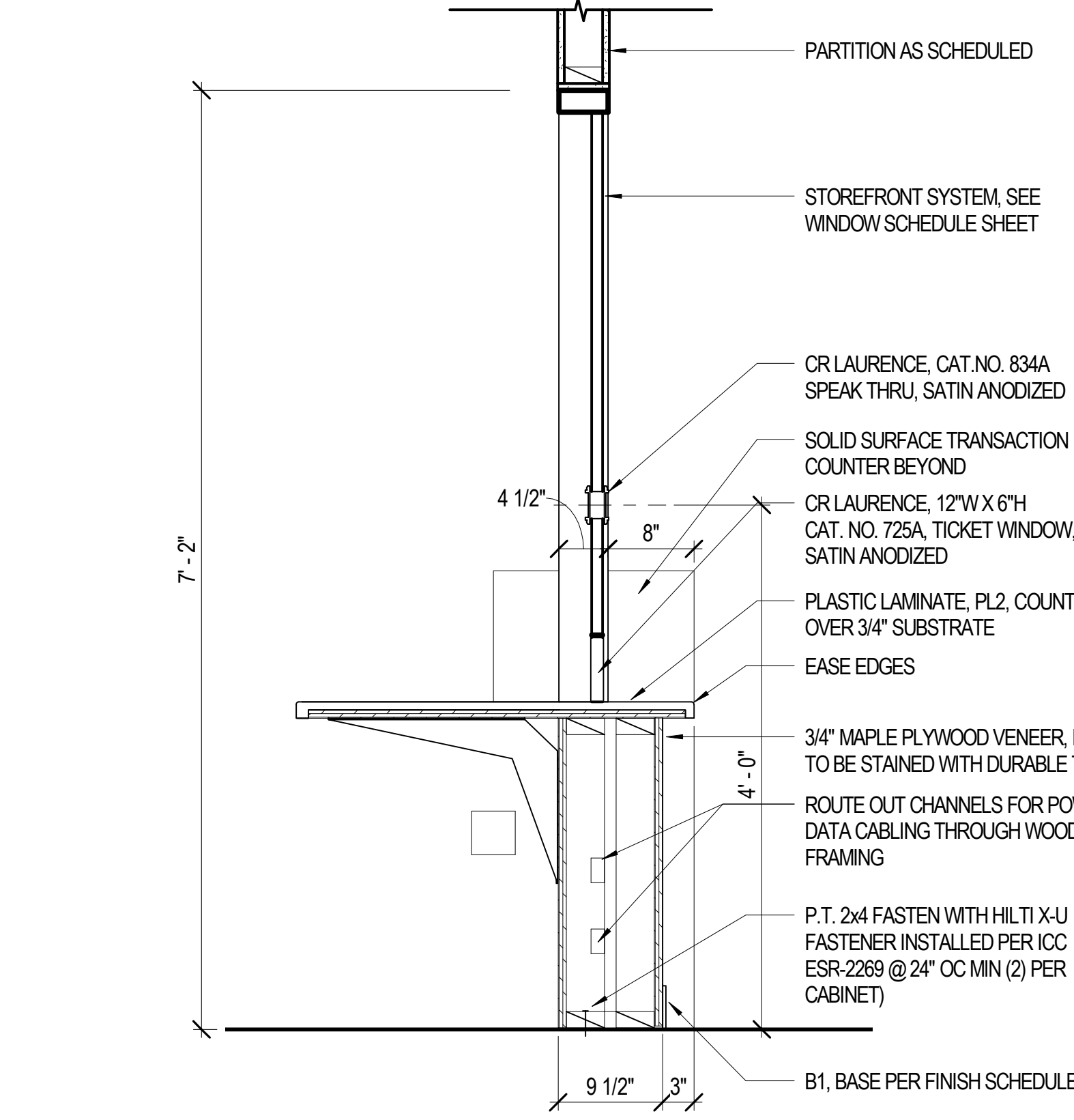

**A3 RECEPTION ACCESSIBLE COUNTER DETAIL**  
A501 1" = 1'-0"

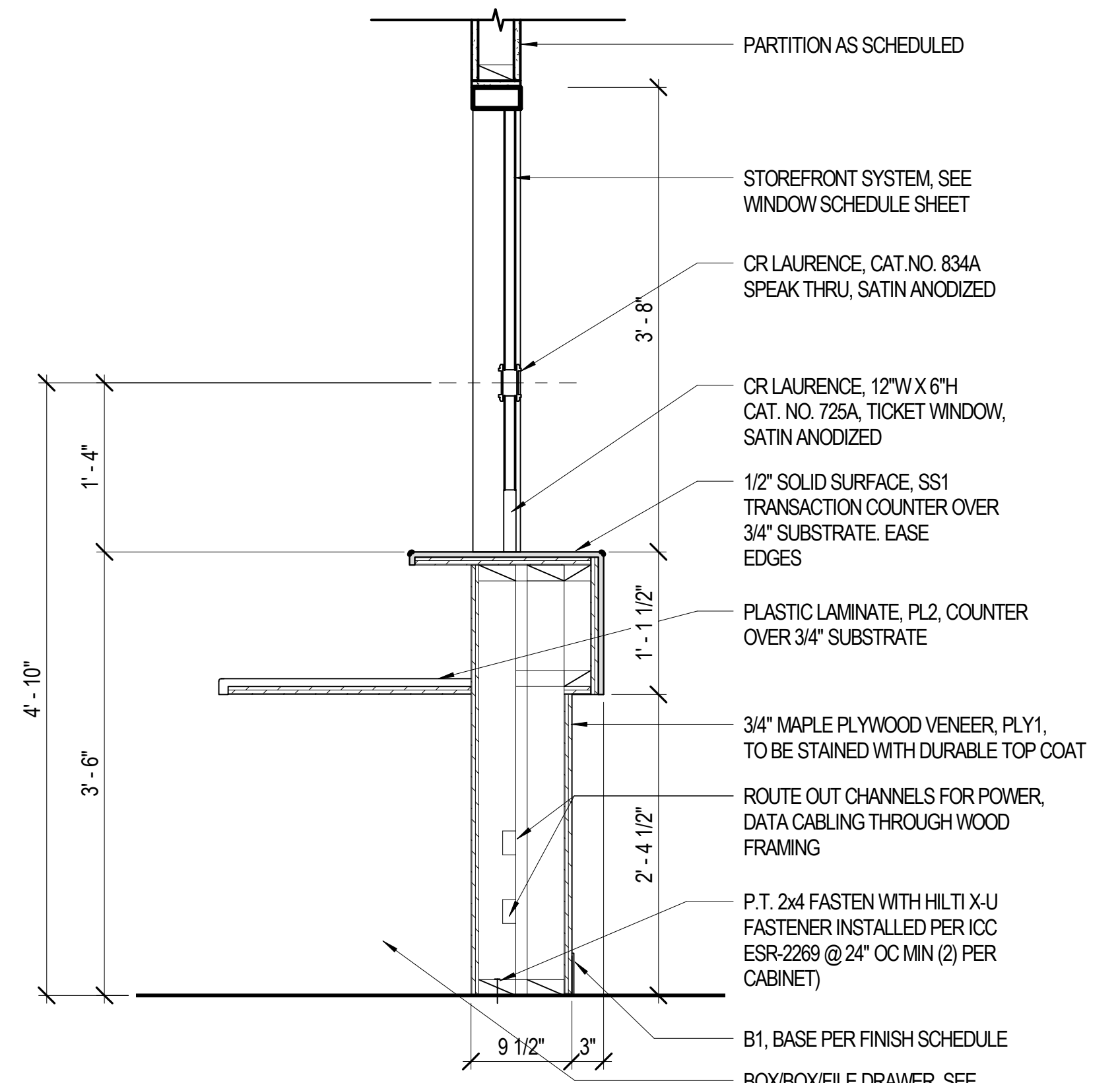

**A4 RECEPTION TRANSACTION COUNTER DETAIL**  
A501 1" = 1'-0"

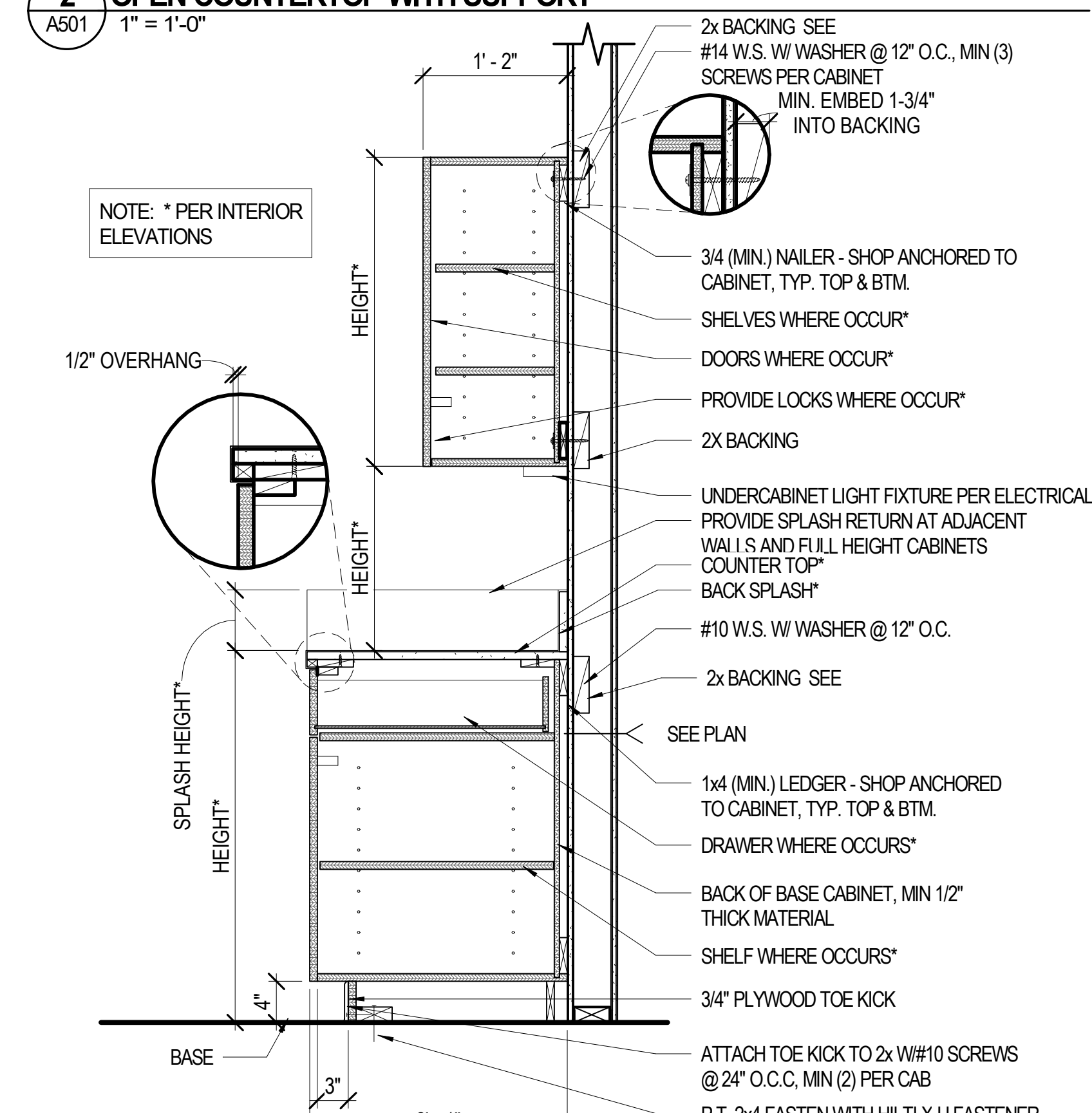

**A5 CASEWORK - BASE & UPPER CABINET**  
A501 1" = 1'-0"

# Date Revision

**CONSTRUCTION DOCUMENTS**

NEXUS PROJ. #: 18117  
CHECKED BY: RP  
DRAWN BY: MR  
DATE: 01.02.2019

**DETAILS**

**A501**  
18-1912 Revised B 9/01/66  
BOS Revd 1-24-19

10/20/19 2:36:49 PM

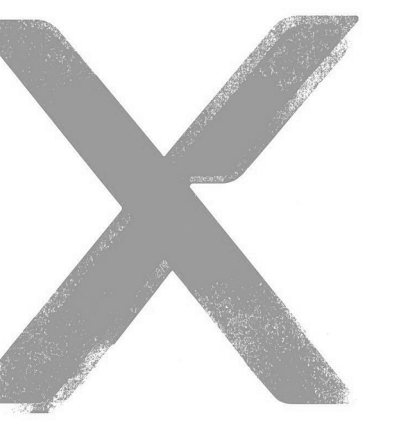

ARCH | NEXUS

Architectural NEXUS, Inc.  
930 R Street  
Sacramento, California 95811  
T 916.443.5911  
http://www.archnexus.com

Original drawings remain the property of the Architect and as such the Architect retains total ownership and control. The design represented by these drawings is sold to the client for a one time use, unless otherwise agreed upon in writing by the Architect. © Architectural Nexus, Inc. 2014



COUNTY OF EL DORADO  
**HHSA TENANT IMPROVEMENT**  
3368 SANDY WAY  
SOUTH LAKE TAHOE, CA 96150

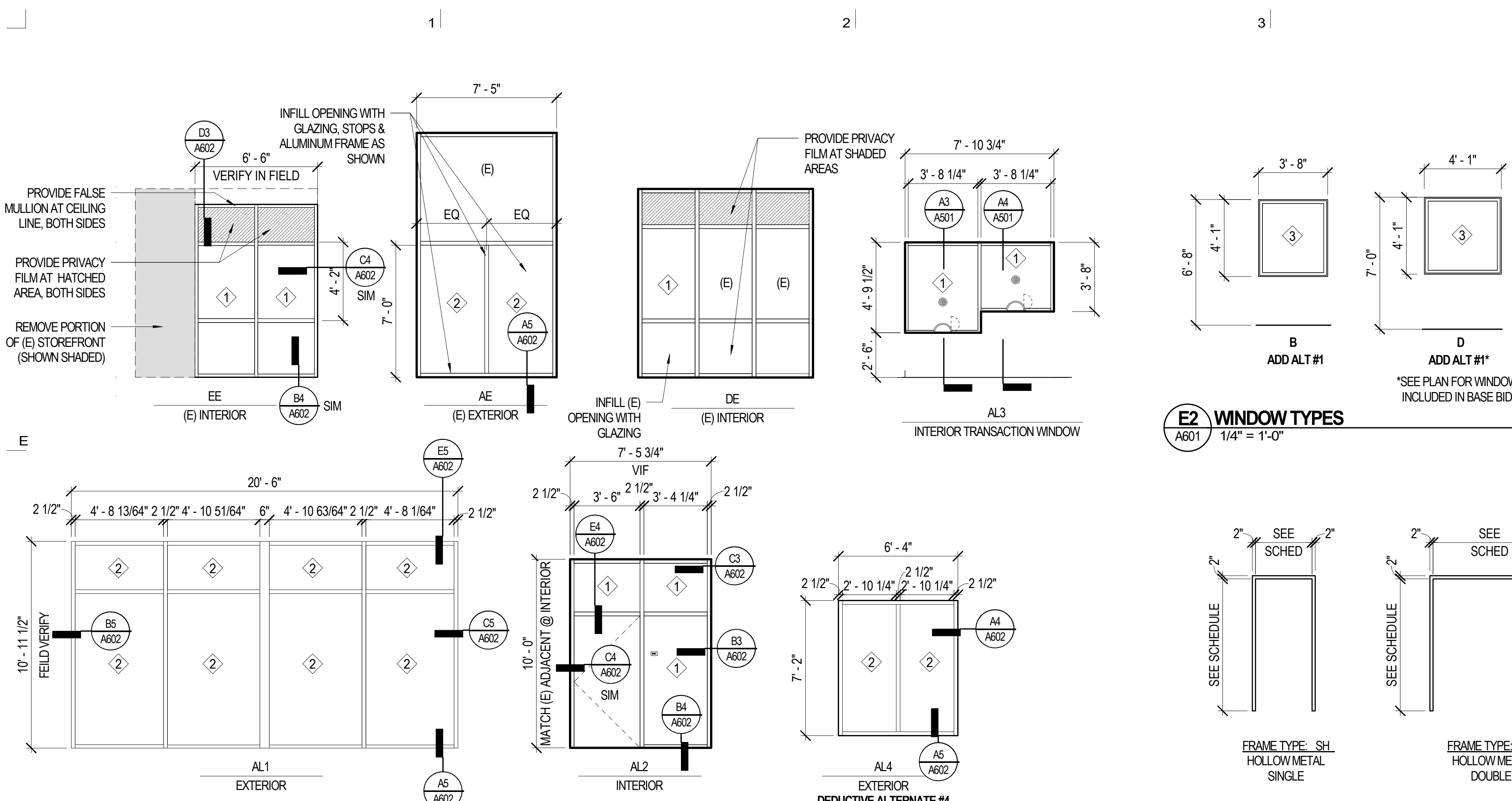

NUMBER	DOOR				FRAME				FIRE RATING	HARDWARE GROUP	NOTES	NUMBER
	SIZE		TYPE	FINISH	HEAD	JAMB	THRES	TYPE				
	WIDTH	HEIGHT										
100	3'-6"	7'-0"	AL01	F	-	-	SEE STOREFRONT TYPE : AL2	F				100
100A	6'-0"	7'-0"	(E)	(E)	(E)	(E)	(E)	(E)				100A
102	3'-0"	7'-0"	WS01	SGV	B4/A601	B4/A601 SIM	-	SH	P2SG			102
105	3'-0"	7'-0"	WS04	SGV	B4/A601	B4/A601 SIM	-	SH	P2SG			105
106	3'-0"	7'-0"	WS01	SGV	B4/A601	B4/A601 SIM	-	SH	P2SG			106
107	3'-0"	7'-0"	WS04	SGV	B4/A601	B4/A601 SIM	-	SH	P2SG			107
108	3'-0"	7'-0"	WS04	SGV	B4/A601	B4/A601 SIM	-	SH	P2SG			108
109	3'-0"	7'-0"	WS01	SGV	B4/A601	B4/A601 SIM	-	SH	P2SG			109
110	3'-0"	6'-8"	HSO4	P2SG	B4/A601	B4/A601 SIM	-	SH	P2SG			110
111	3'-0"	7'-0"	WS01	SGV	B4/A601	B4/A601 SIM	-	SH	P2SG			111
112	3'-0"	7'-0"	WS01	SGV	B4/A601	B4/A601 SIM	-	SH	P2SG			112
113	3'-0"	7'-0"	WS01	SGV	B4/A601	B4/A601 SIM	-	SH	P2SG			113
114	3'-0"	7'-0"	WS01	SGV	B4/A601	B4/A601 SIM	-	SH	P2SG			114
115	3'-0"	7'-0"	WS01	SGV	B4/A601	B4/A601 SIM	-	SH	P2SG			115
116	3'-0"	7'-0"	WS01	SGV	B4/A601	B4/A601 SIM	-	SH	P2SG			116
117	3'-0"	7'-0"	WS04	SGV	B4/A601	B4/A601 SIM	-	SH	P2SG			117
118	3'-0"	7'-0"	HSO3	P2SG	A6/A601	B6/A601	B5/A601	SH	P2SG			118
119	3'-0"	7'-0"	WS04	SGV	B4/A601	B4/A601 SIM	-	SH	P2SG			119
120	3'-0"	7'-0"	WS04	SGV	B4/A601	B4/A601 SIM	-	SH	P2SG			120
121	3'-0"	7'-0"	HS01	P2SG	B4/A601	B4/A601 SIM	-	SH	P2SG			121
121A	3'-0"	7'-0"	(E)	(E)	(E)	(E)	(E)	(E)	P2SG			121A
122	3'-0"	7'-0"	(E)	(E)	(E)	(E)	(E)	(E)	P2SG			122
123	6'-0"	7'-0"	(E)	(E)	(E)	(E)	(E)	(E)	(E)			123
123A	3'-0"	7'-0"	(E)	(E)	(E)	(E)	(E)	(E)	(E)			123A
123B	3'-0"	7'-0"	WS04	SGV	B4/A601	B4/A601 SIM	-	SH	P2SG			123B
124	5'-8"	6'-8"	WD01	SGV	B4/A601	B4/A601 SIM	-	SH	P2SG			124
125	6'-0"	7'-0"	(E)	(E)	(E)	(E)	(E)	(E)	(E)			125
126	6'-0"	7'-0"	(E)	(E)	(E)	(E)	(E)	(E)	(E)			126

ABBREVIATIONS		NOTES	
P2SG	PAINT COLOR P2; SEMI-GLOSS	A	MAXIMUM EFFORT TO OPERATE DOORS SHALL NOT EXCEED 5#S FOR EXTERIOR DOORS, 5#S FOR INTERIOR DOORS PER 2016 CBC 11B-404
F	FACTORY FINISH	B	MOUNT PANO DEVICE 3'-4" AFF (TOP SHALL NOT EXCEED 3'-6" AFF)
SGV	SEMI-GLOSS VARNISH	C	LEVER PLACEMENT SHALL BE 3'-4" AFF
DOOR SCHEDULE NOTES		D	SEE DETAIL A4/A601 FOR TYPICAL HOLLOW METAL FRAME INFORMATION
1	KEYCARD ACCESS	E	SEE DETAIL A5/A601 FOR DOORS NOT DIMENSIONED ON FLOOR PLAN
2	EXISTING DOOR TO REMAIN - PROVIDE NEW HARDWARE	F	SEE SPEC SECTION FOR HARDWARE GROUPS
3	DEDUCTIVE ALTERNATE #3 - SEE SHEET A102		
4	STC 50 RATING		
5	HARDWARE TO BE PROVIDED & INSTALLED BY SONITROL		
6	REKEY DOOR IF REUSED		
7	PROVIDE FRAMES w ANSI PREPPED STRIKE, 4-7/8" & RCI ELECTRIFIED STRIKE. ELECTRIFIED STRIKE CONNECTION BY SONITROL GC TO PROVIDE & INSTALL ELECTRIFIED STRIKE.		
8	(E) NO WORK AT THIS OPENING		
9	DELAYED EGRESS - ALARMED EXITING		

WINDOW SCHEDULE									
Type Mark	R.O.		Type	Finish	Head	Jamb	Sill	Glazing Type	Comments
B	3'-8"	4'-1"	WN_Fixed	ALUM - F	A1/A601 SIM	A1/A601 SIM	A1/A601 SIM	SEE WINDOW TYPE	ADD ALT #1
D	4'-1"	4'-1"	WN_Fixed	ALUM - F	A1/A601	A1/A601	A1/A601	SEE WINDOW TYPE	ADD ALT #1, UNO

- GENERAL NOTE - WINDOW TYPES**
- A. FIELD VERIFY ALL DIMENSIONS PRIOR TO SHOP DRAWING SUBMITTAL & SUBSEQUENT FABRICATION OF ALL DOOR AND WINDOW FRAMES.
  - B. PROVIDE CLEARANCE REQUIRED BY ACCESSIBILITY CODES ANSI A117.1 AND ADAAG AT ALL DOORS, AS DEPICTED IN DETAILS ON SHEET G002.
- GLAZING SCHEDULE**
- 1. 1/4" TEMPERED GLAZING UNIT
  - 2. 1/4" TEMPERED INSULATED CLEAR GLAZING UNIT
  - 3. 1/4" INSULATED REFLECTIVE GLAZING UNIT

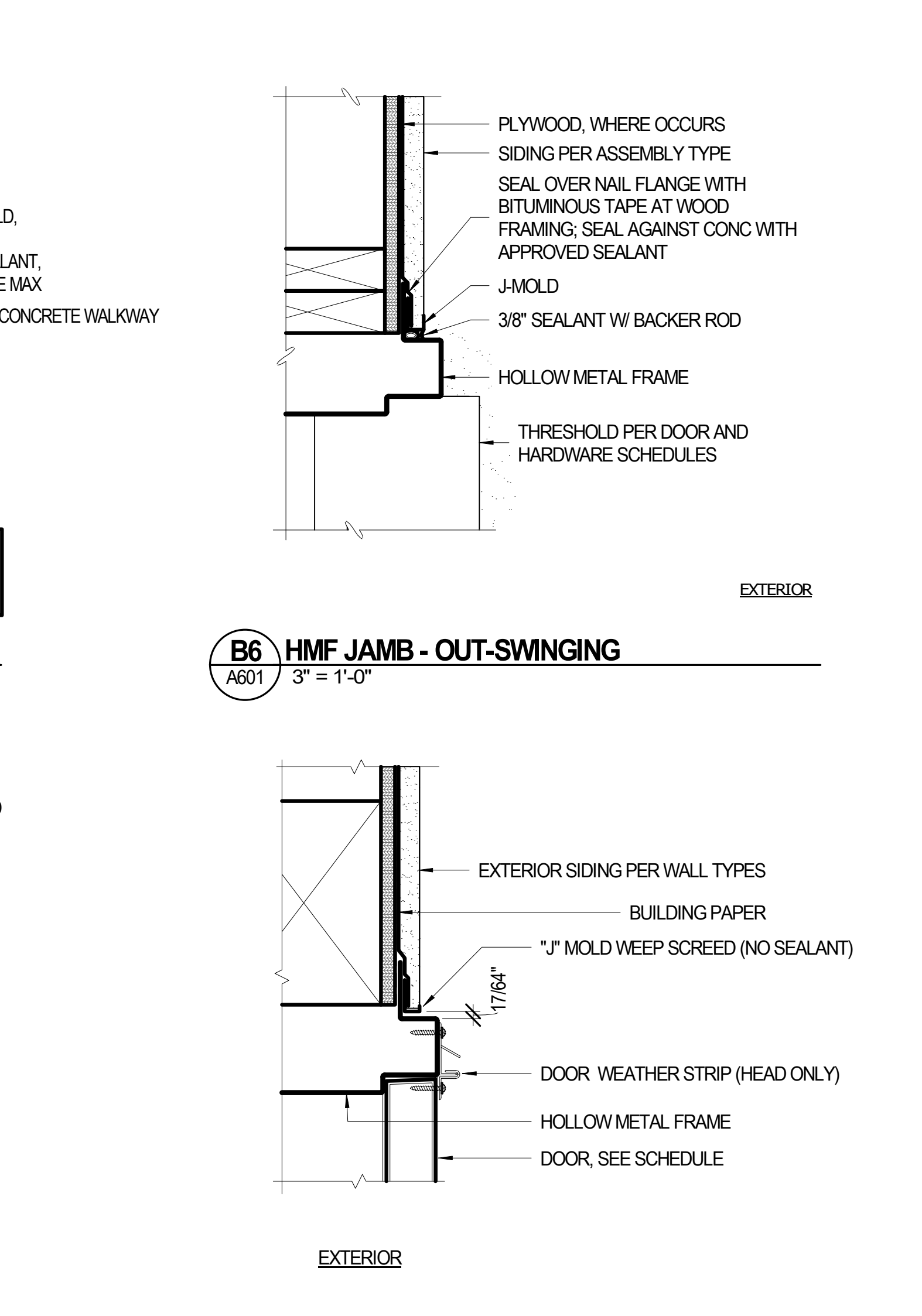
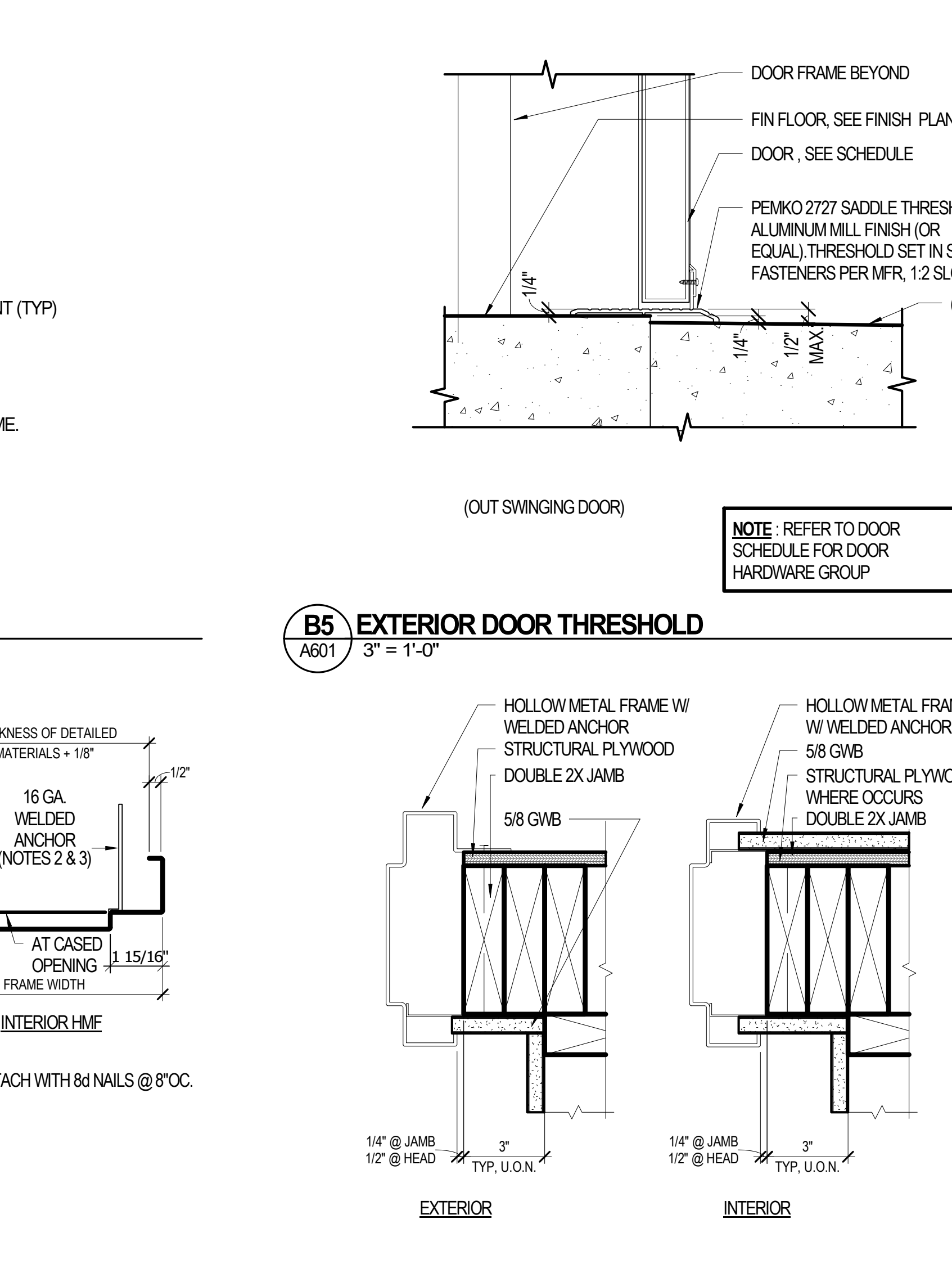
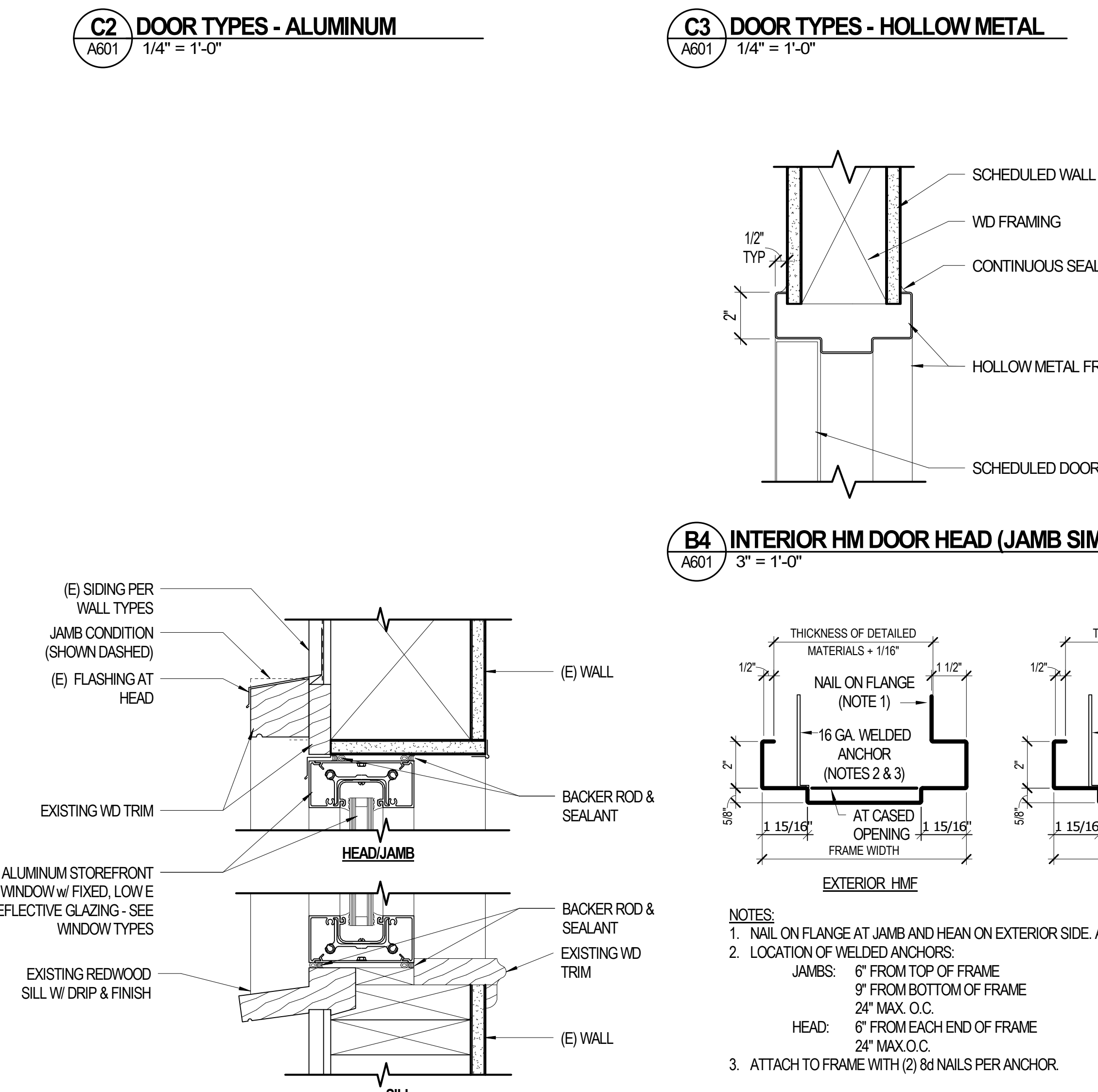
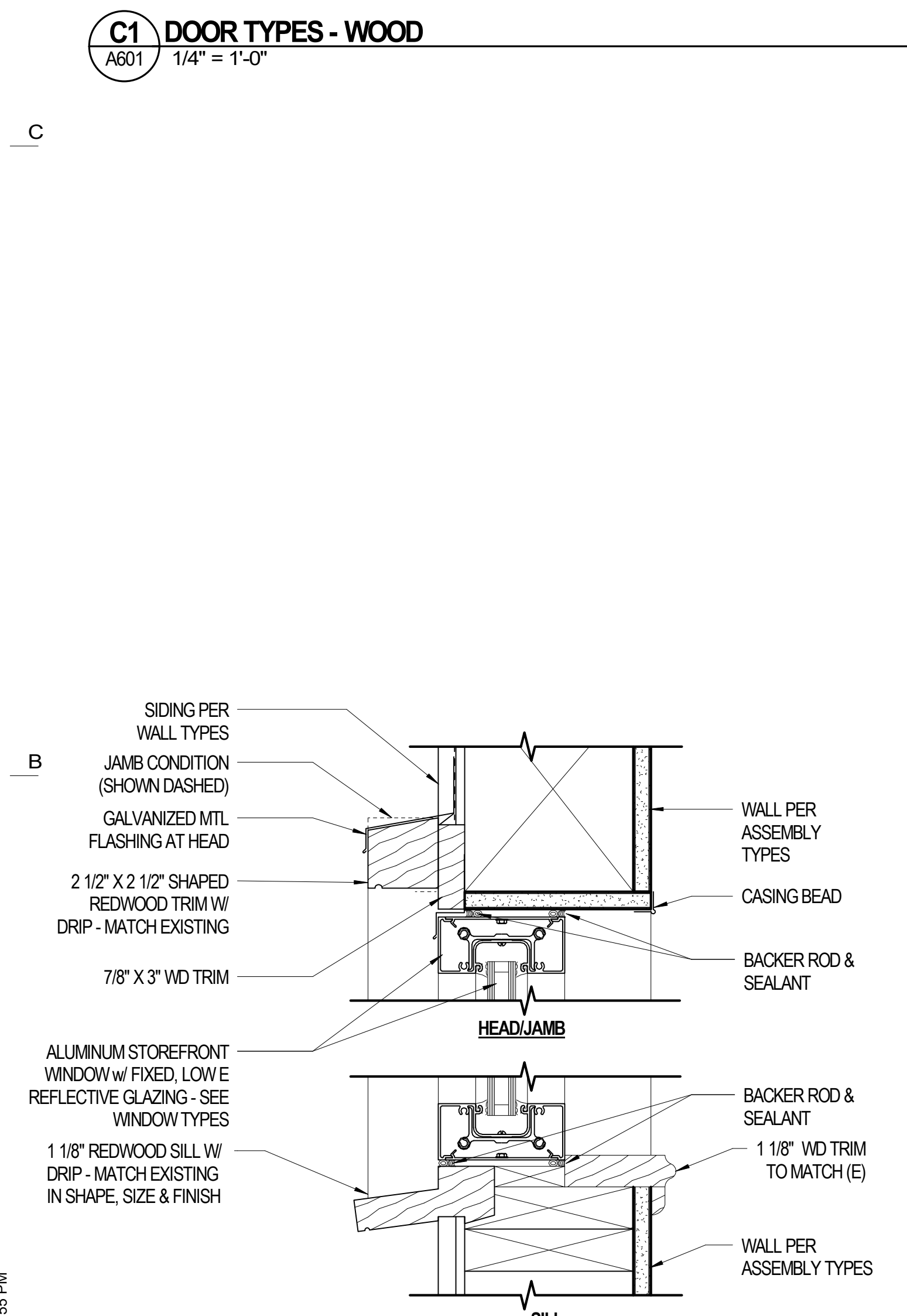
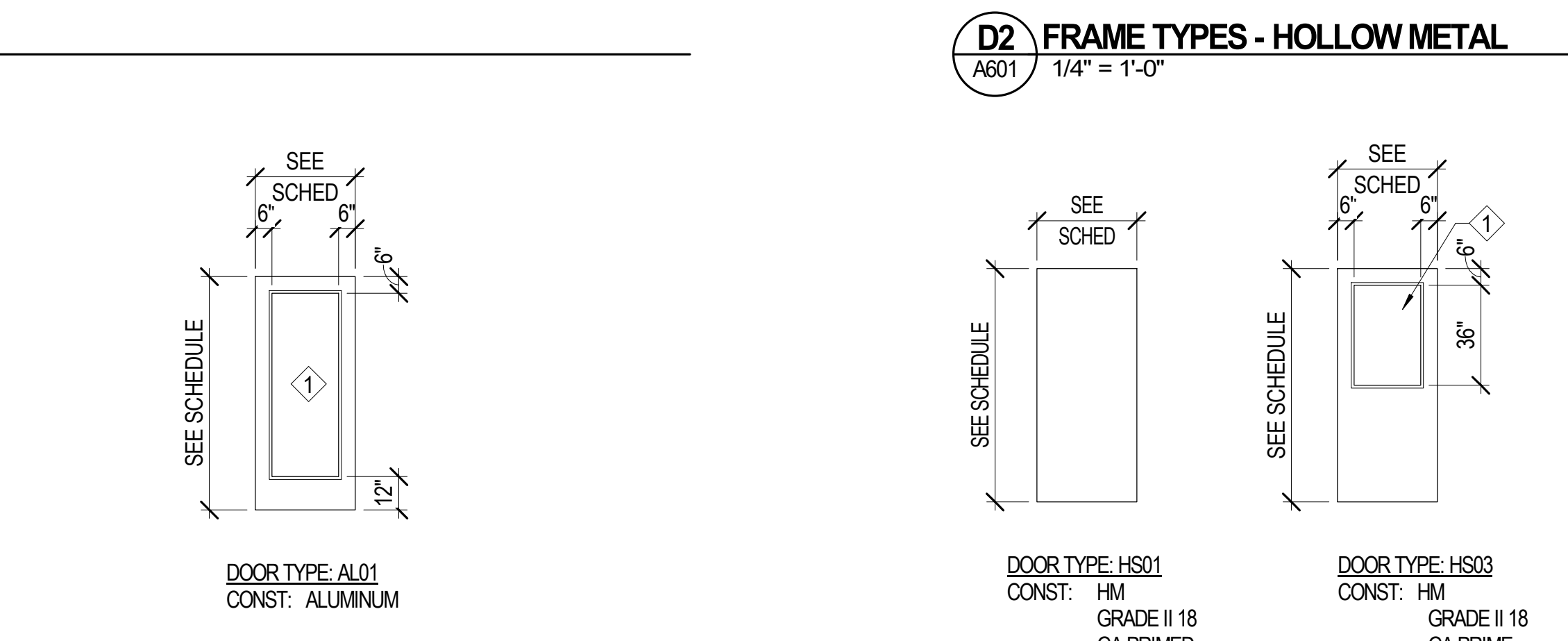
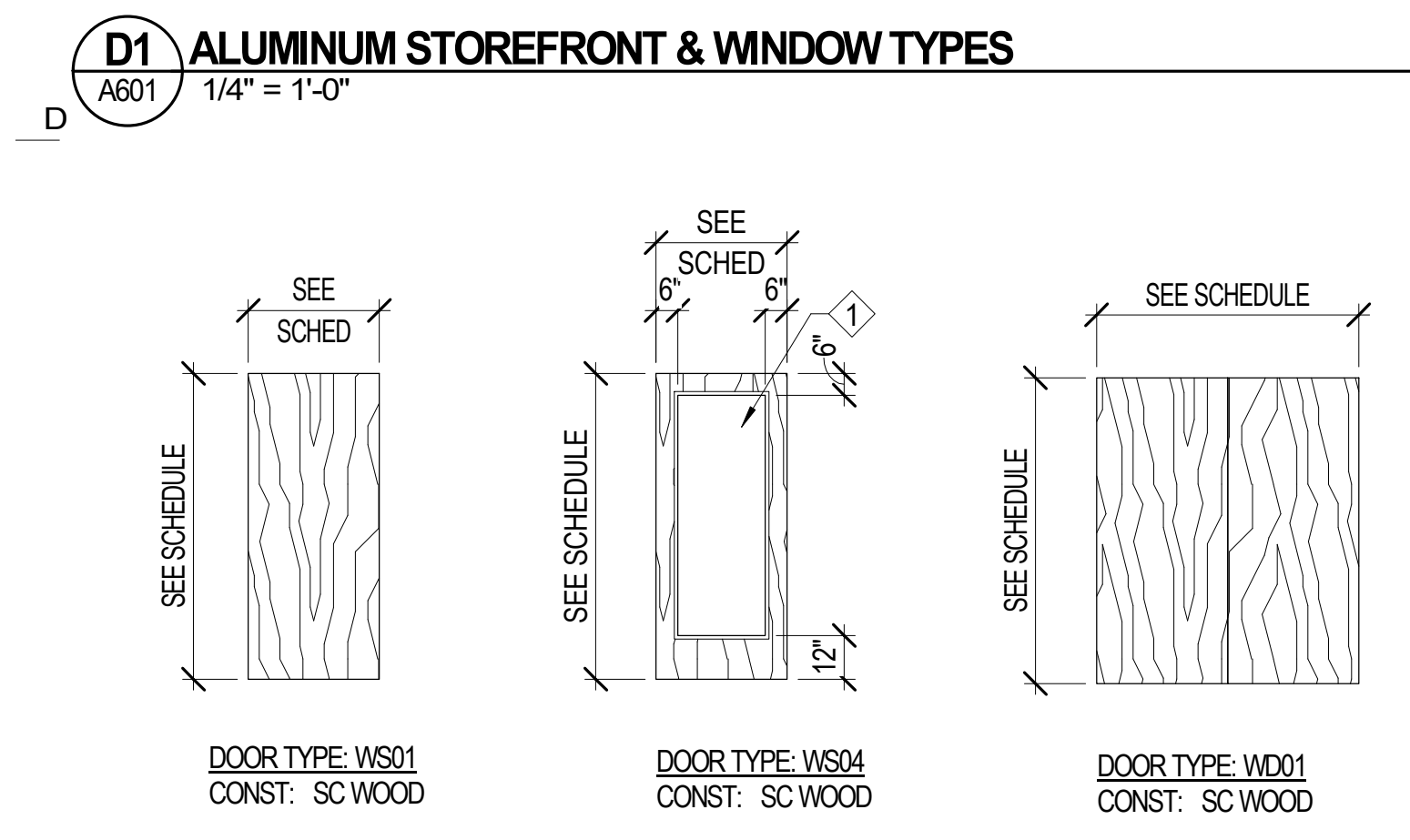

**A1 ALUMINUM WINDOW DETAIL**  
A601 3" = 1'-0"

**A4 HOLLOW METAL FRAMES ANCHORAGE**  
A601 3" = 1'-0"

**A5 HOLLOW METAL FRAME - JAMB**  
A601 3" = 1'-0"

**A6 HOLLOW METAL FRAME - HEAD EXTERIOR**  
A601 3" = 1'-0"

**CONSTRUCTION DOCUMENTS**  
NEXUS PROJ. #: 18117  
CHECKED BY: RP  
DRAWN BY: MR  
DATE: 01.02.2019  
**WINDOW AND DOOR SCHEDULES AND DETAILS**

**A601**  
18-1912 Revised B 91 of 606  
BOS Rcvd 1-24-19

E  
D  
C  
B  
A

1

2

3

4

5

6

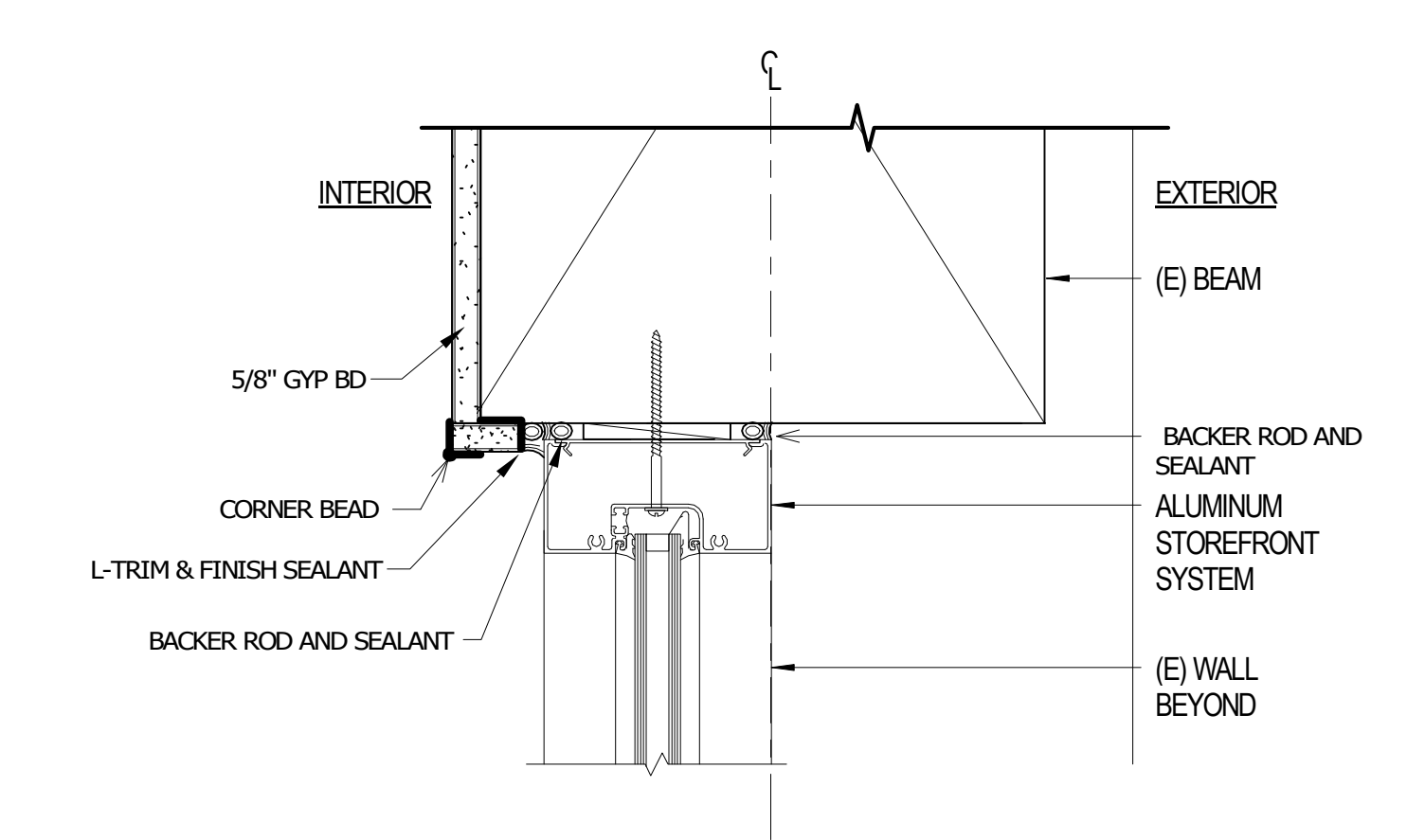
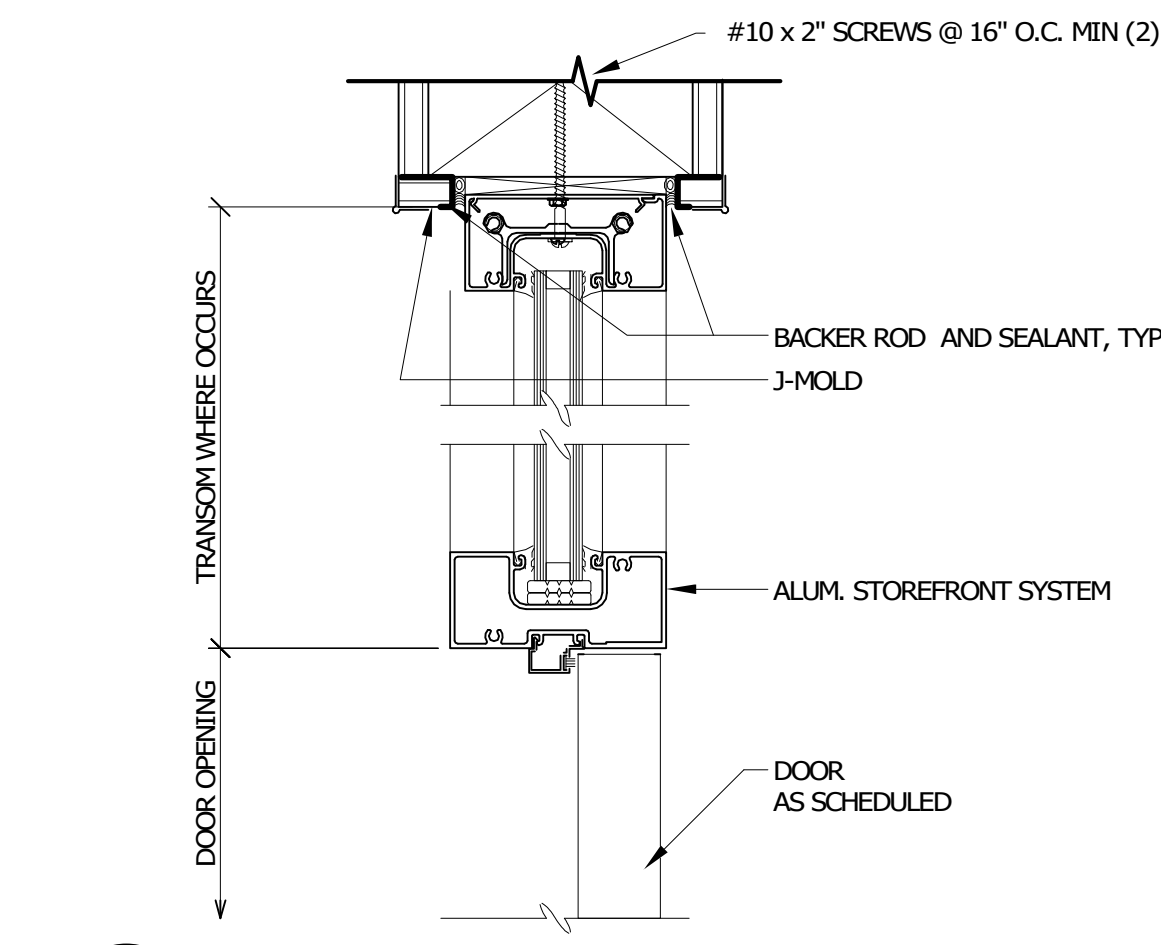
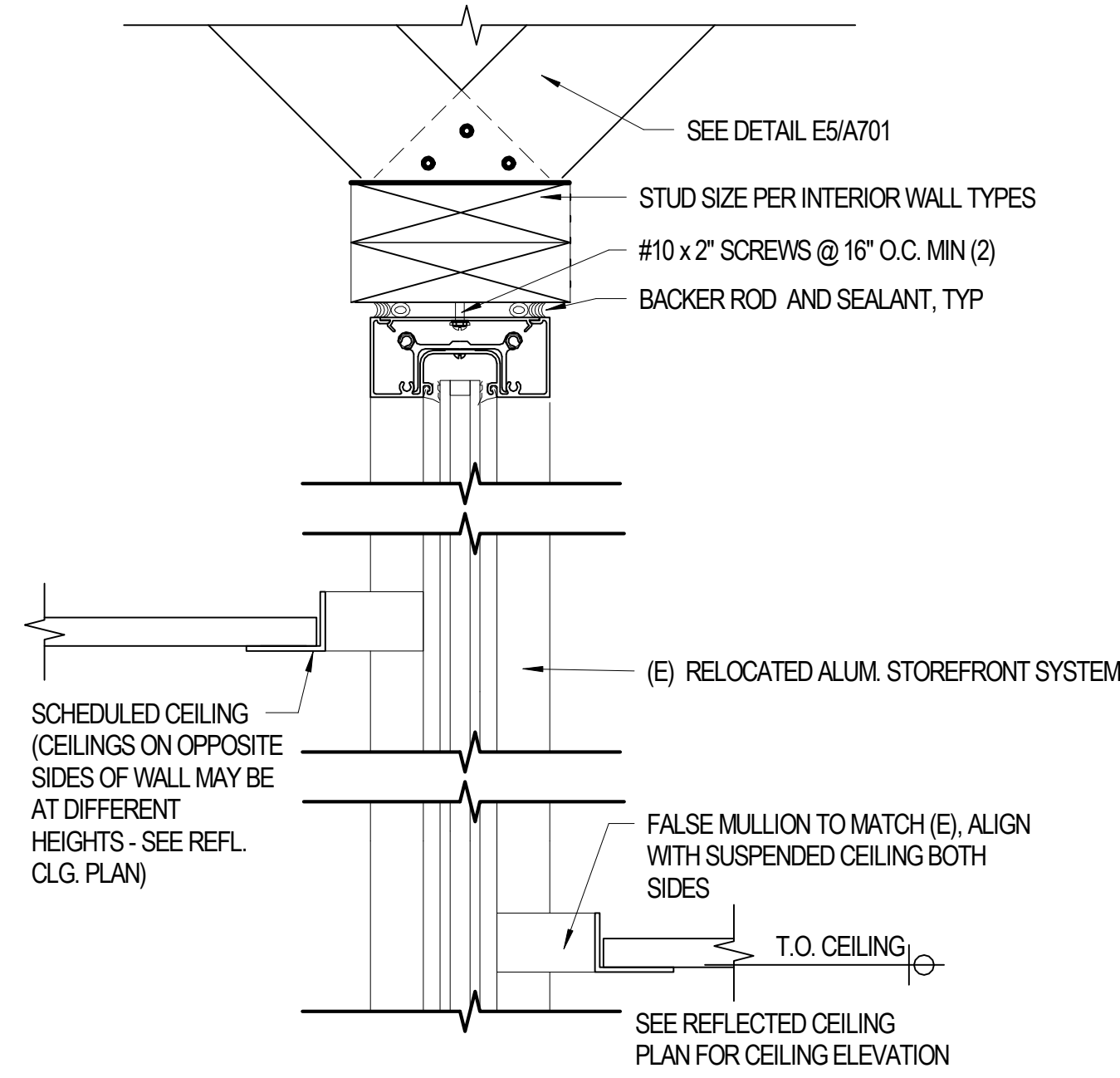

**D3 INTERIOR STOREFRONT**  
 A602 3" = 1'-0"

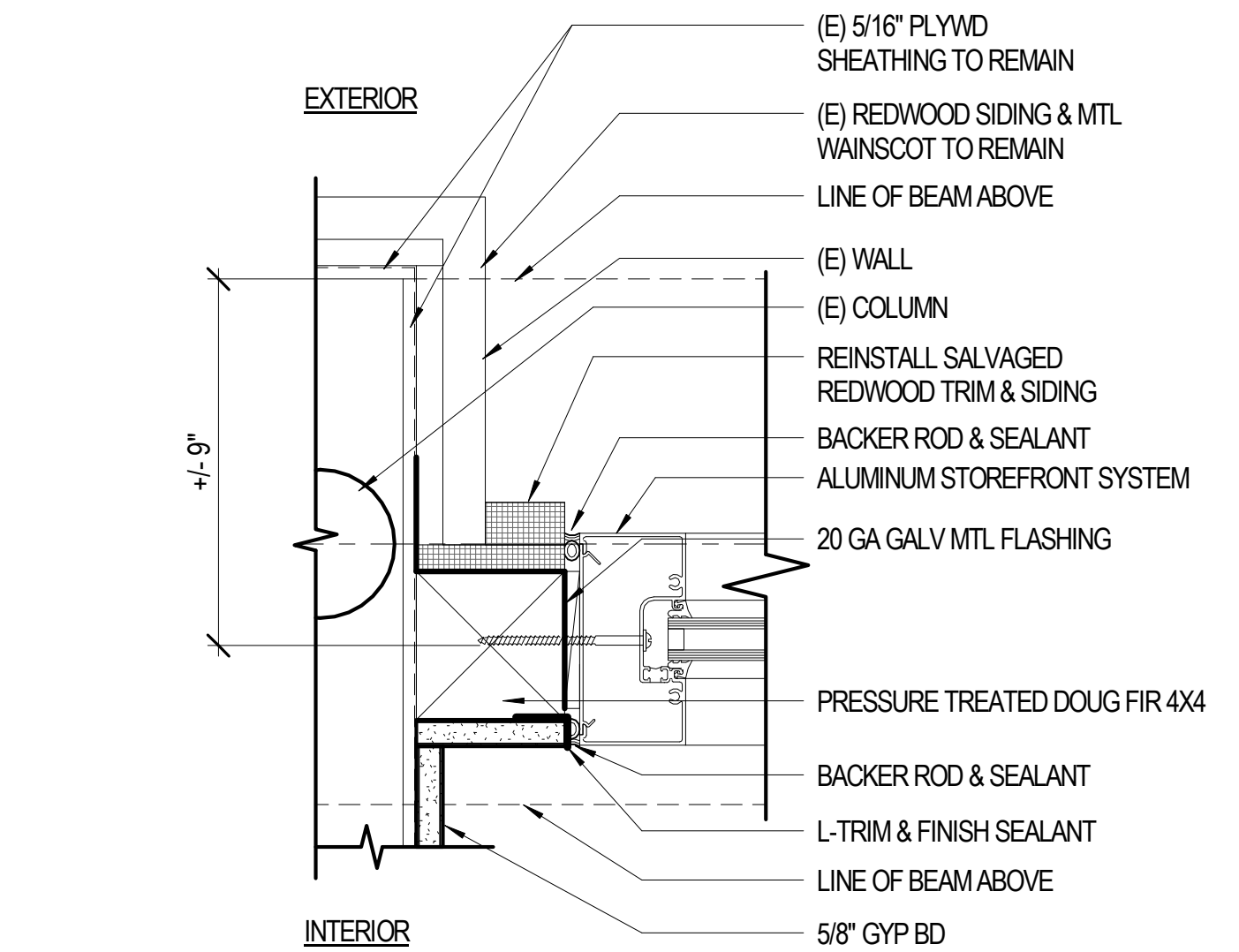
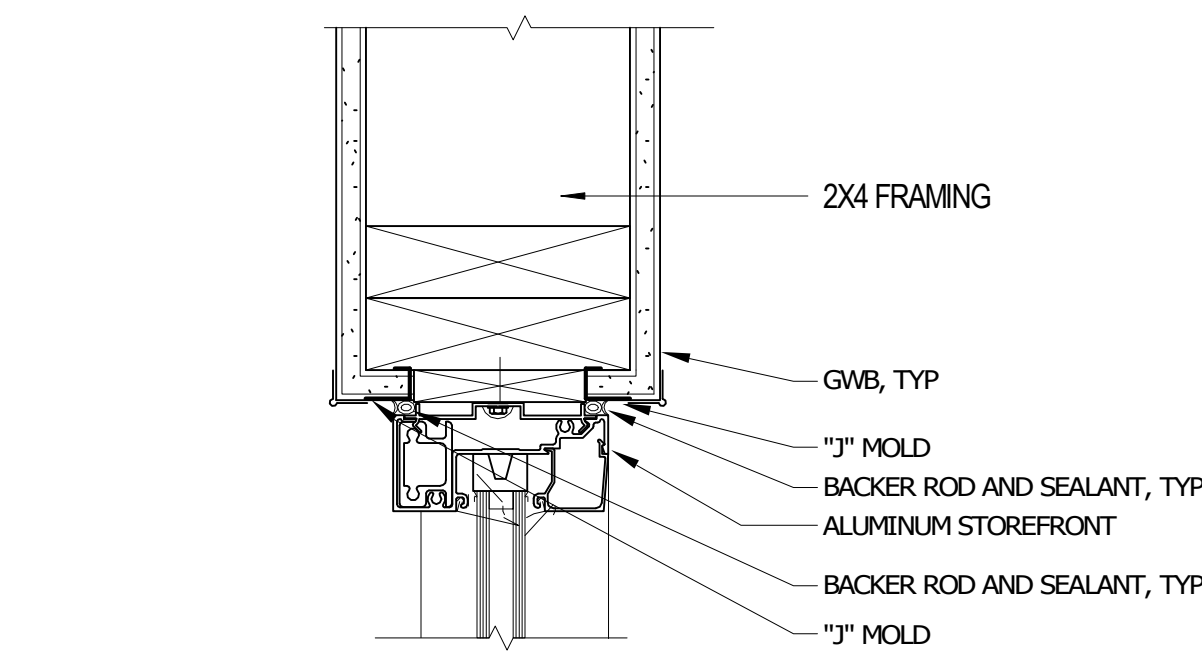
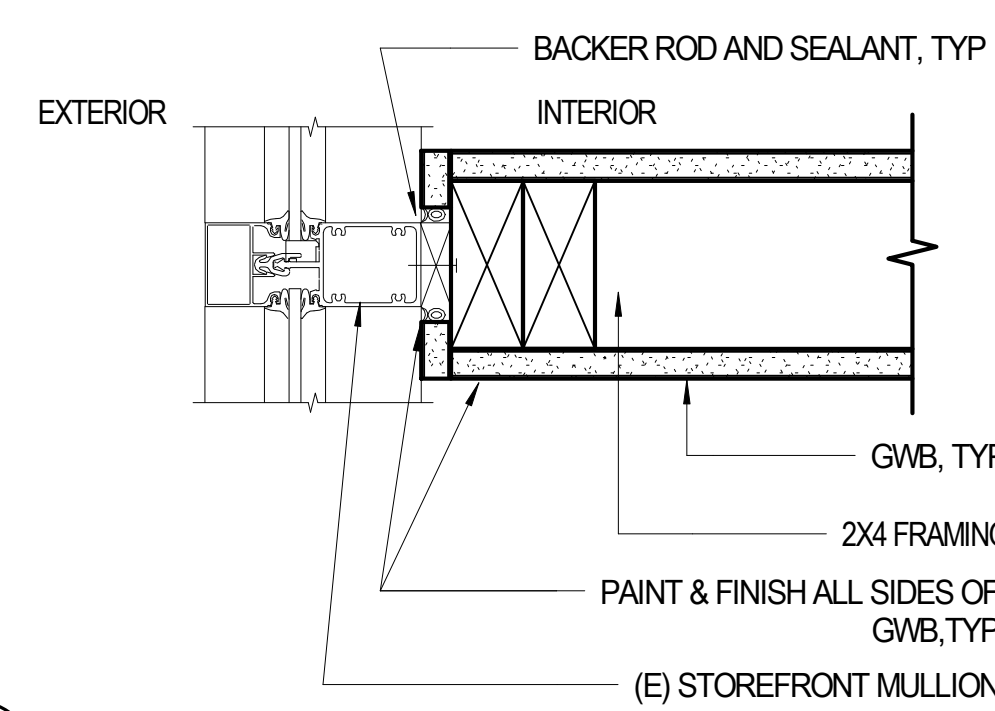

**C3 INTERIOR STOREFRONT JAMB A**  
 A602 3" = 1'-0"

**C4 INTERIOR STOREFRONT HEAD/JAMB**  
 A602 3" = 1'-0"

**C5 EXTERIOR STOREFRONT JAMB AT EXISTING WALL**  
 A602 3" = 1'-0"

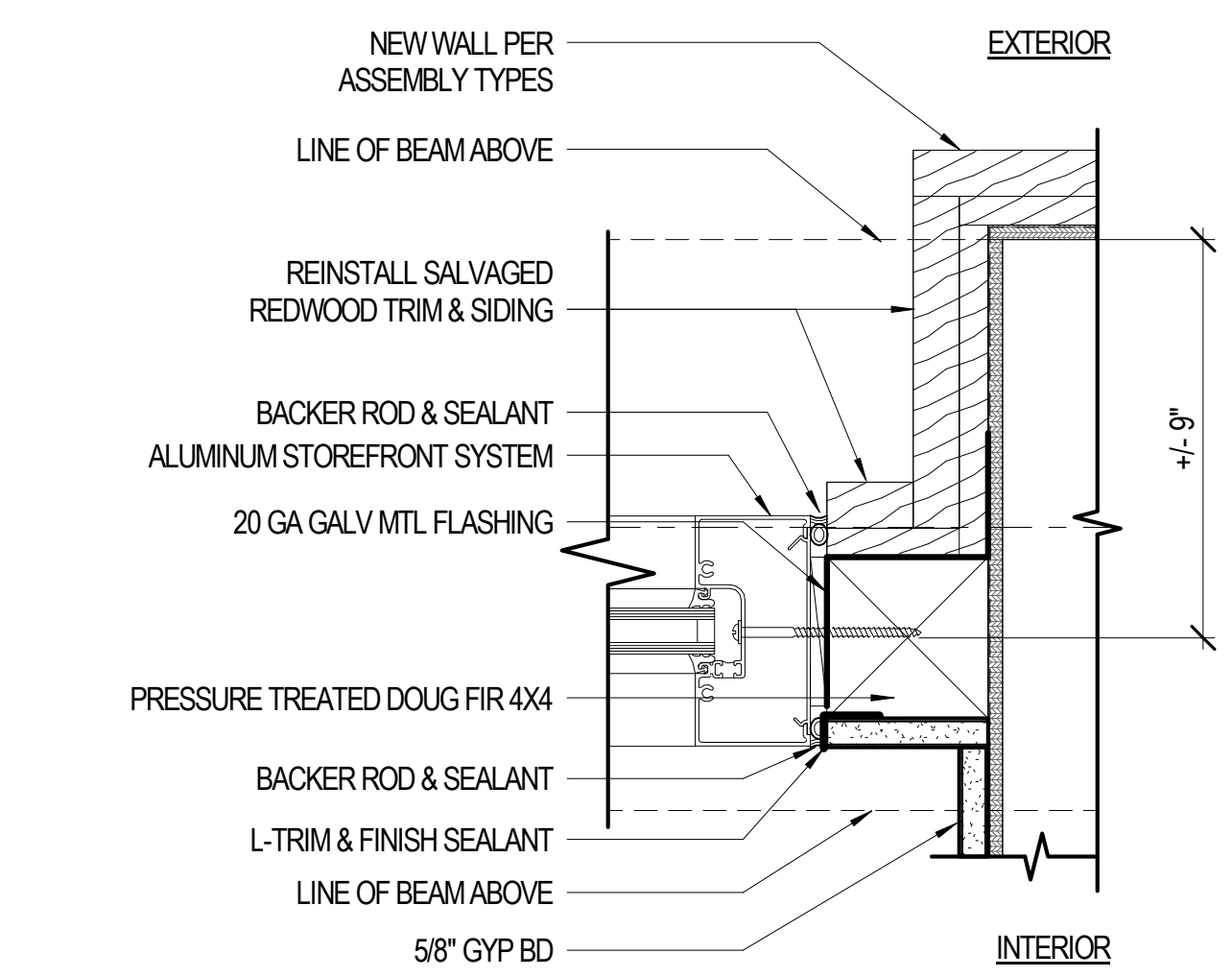
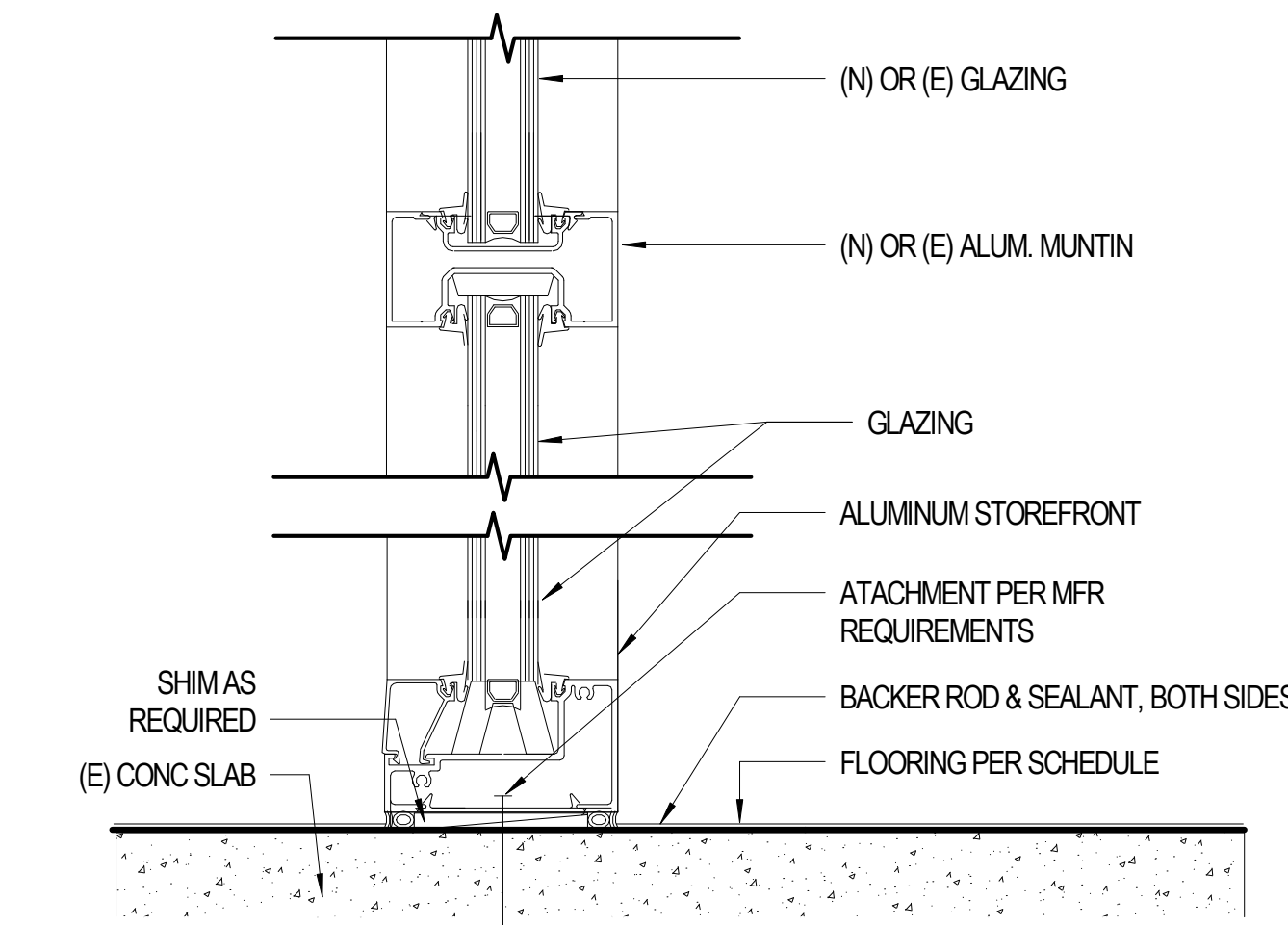
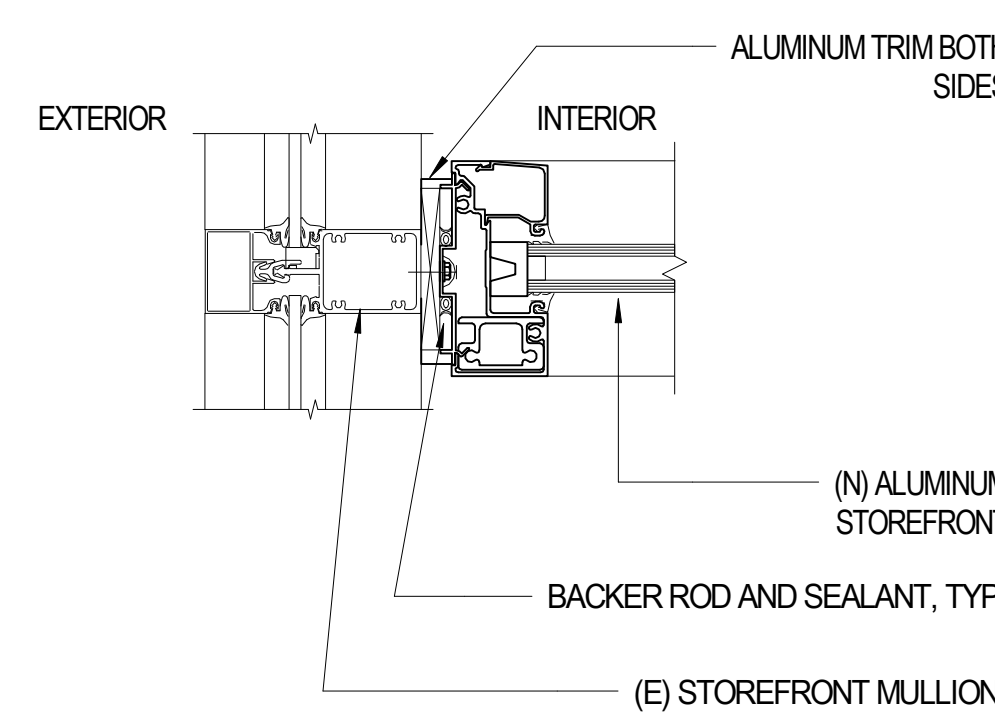

**B3 INTERIOR STOREFRONT JAMB B**  
 A602 3" = 1'-0"

**B4 STOREFRONT SILL**  
 A602 3" = 1'-0"

**B5 EXTERIOR STOREFRONT JAMB AT NEW WALL**  
 A602 3" = 1'-0"

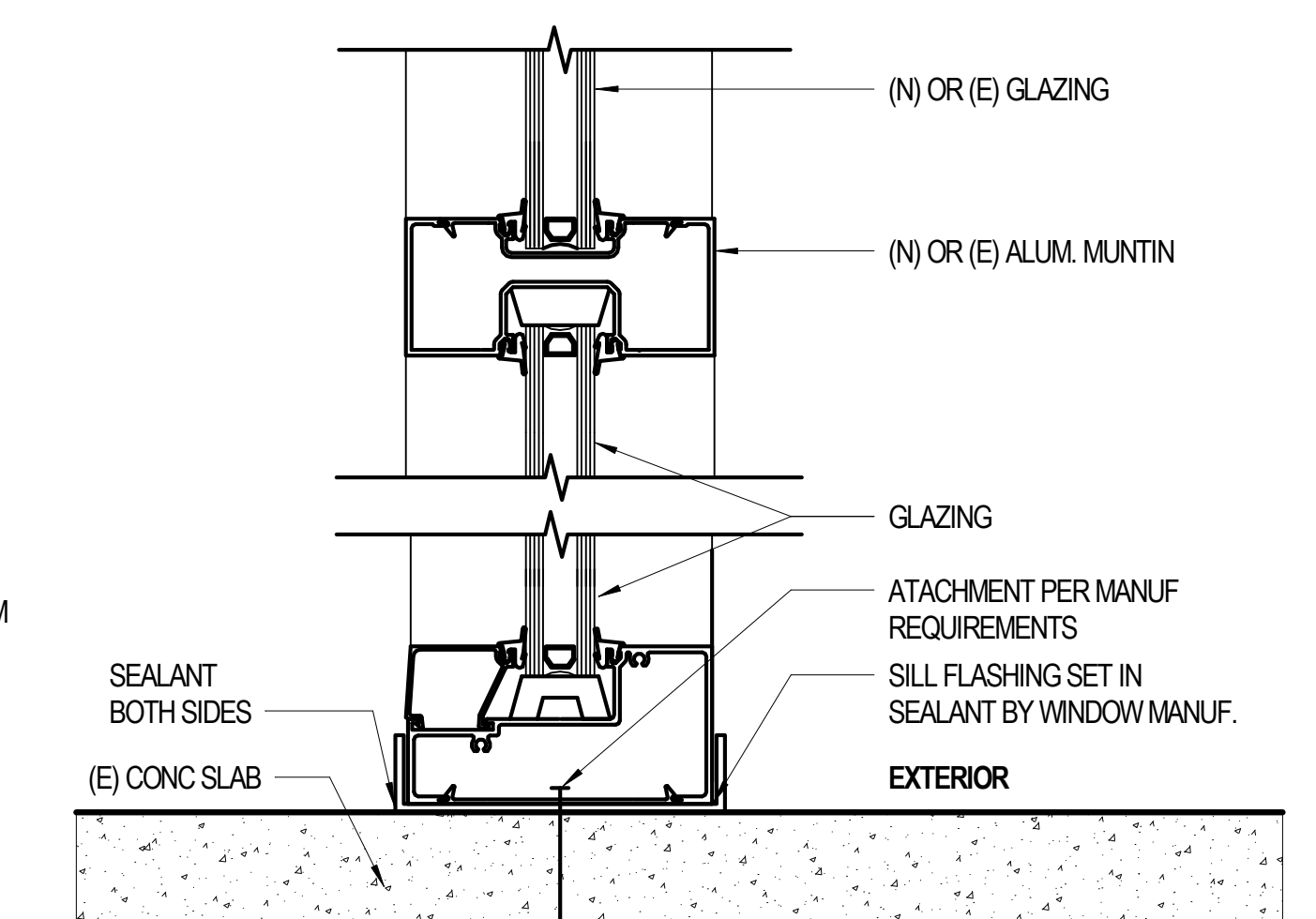
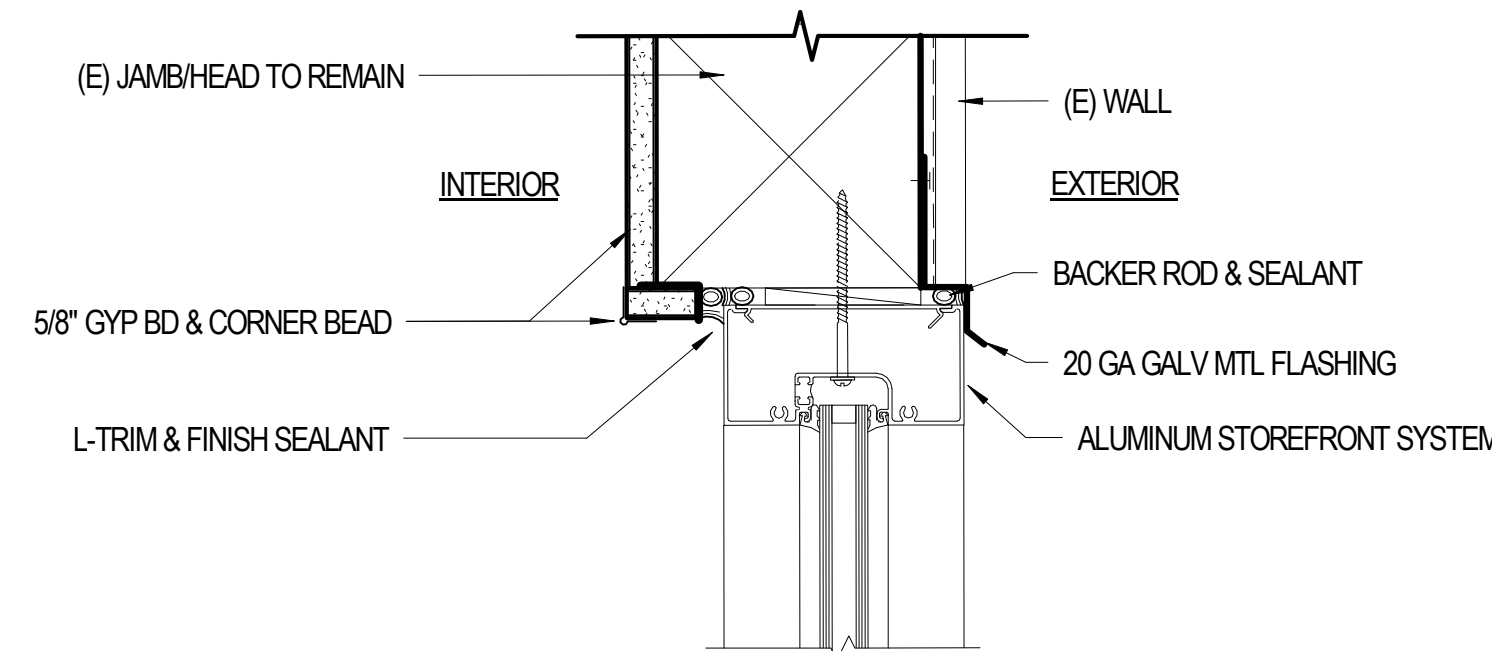

**A4 STOREFRONT HEAD/JAMB DEDUCTIVE ALTERNATE #3**  
 A602 3" = 1'-0"

**A5 EXTERIOR STOREFRONT SILL**  
 A602 3" = 1'-0"

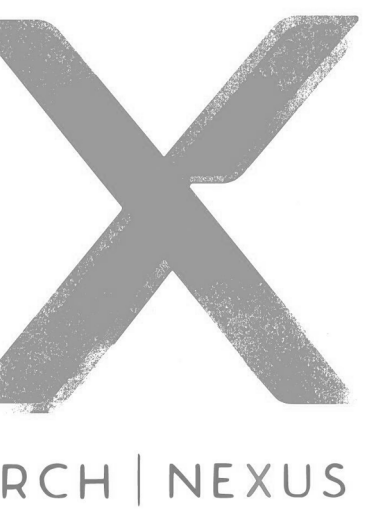

Architectural NEXUS, Inc.  
 930 R Street  
 Sacramento, California 95811  
 T 916.443.5911  
 http://www.archnexus.com

Original drawings remain the property of the Architect and as such the Architect retains total ownership and control. The design represented by these drawings is sold to the client for a one time use, unless otherwise agreed upon in writing by the Architect. © Architectural Nexus, Inc. 2014



COUNTY OF EL DORADO  
**HHSA TENANT IMPROVEMENT**  
 3368 SANDY WAY  
 SOUTH LAKE TAHOE, CA 96150

# Date Revision

**CONSTRUCTION DOCUMENTS**

NEXUS PROJ. #: 18117  
 CHECKED BY: RP  
 DRAWN BY: MR  
 DATE: 01.02.2019

**WINDOW DETAILS**

**A602**  
 18-1912 Revised B 9/2/06  
 BOS Revd 1-24-19

14/02/2019 7:32:11 AM

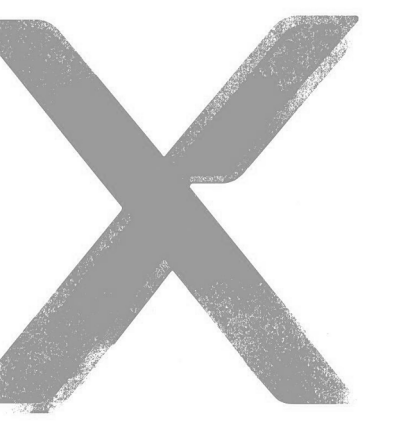

ARCH | NEXUS

Architectural NEXUS, Inc.  
930 R Street  
Sacramento, California 95811  
T 916.443.5911  
http://www.archnexus.com

Original drawings remain the property of the Architect, and as such the Architect retains total ownership and control. The design represented by these drawings is sold to the client for a one time use, unless otherwise agreed upon in writing by the Architect. © Architectural Nexus, Inc. 2014



COUNTY OF EL DORADO  
**HHSA TENANT IMPROVEMENT**  
3368 SANDY WAY  
SOUTH LAKE TAHOE, CA 96150

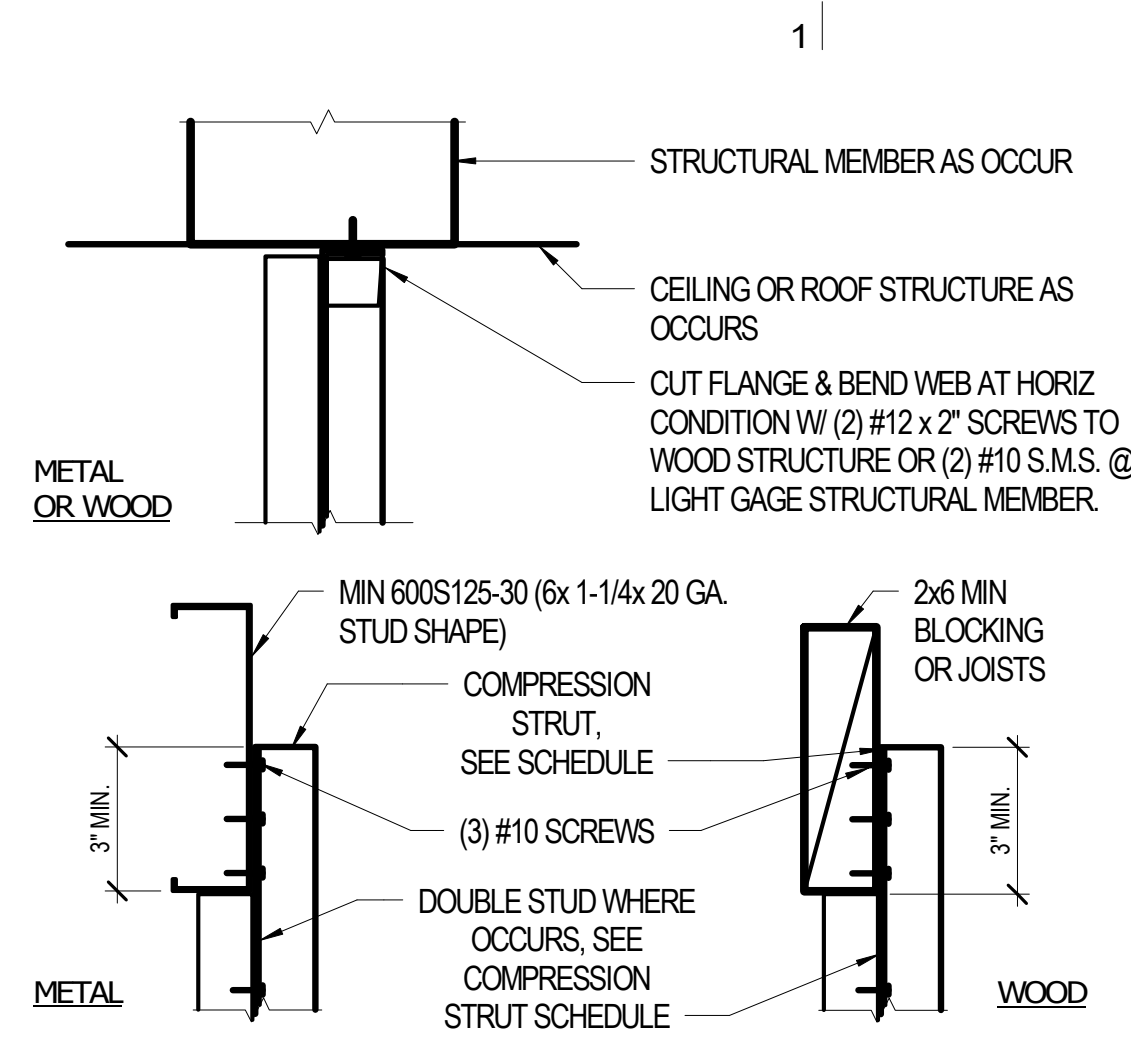

**E2 COMPRESSION STRUT ANCHORAGE**  
A701 3" = 1'-0"

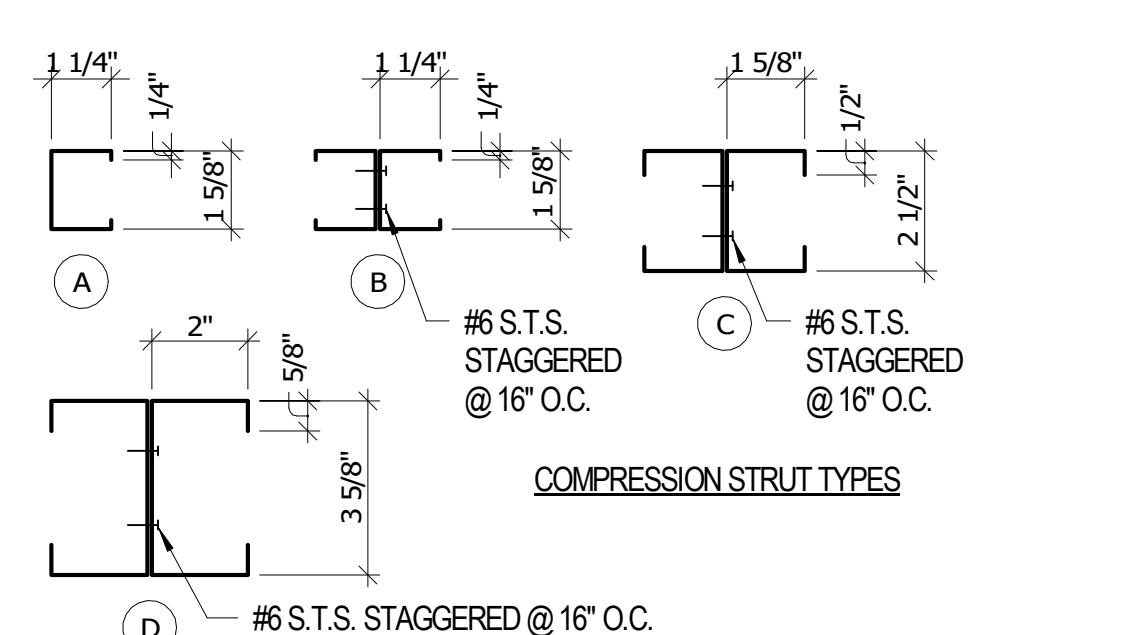

COMPRESSION STRUT SCHEDULE (H < 200)

TYPE	MAX HEIGHT	DESCRIPTION	SSMA* DESIGNATION	ry	rx
A	7'-4"	1-5/8" x 1 1/4" STUD	162S125	0.440	0.679
B	10'-6"	2-1 5/8" x 1 1/4" STUDS	162S125	0.630	0.675
C	14'-9"	2-2 1/2" x 1 5/8" STUDS	250S162	0.889	1.027
D	17'-9"	2-3 5/8" x 2" STUDS	362S200	1.064	1.471

\* STEEL STUD MANUFACTURERS ASSOCIATION STUD DIMENSIONS SHALL BE AS DETAILED (SSMA STANDARDS). STEEL THICKNESS SHALL BE BETWEEN 25 AND 20 GAUGE (.0188" TO .0346" THICK)

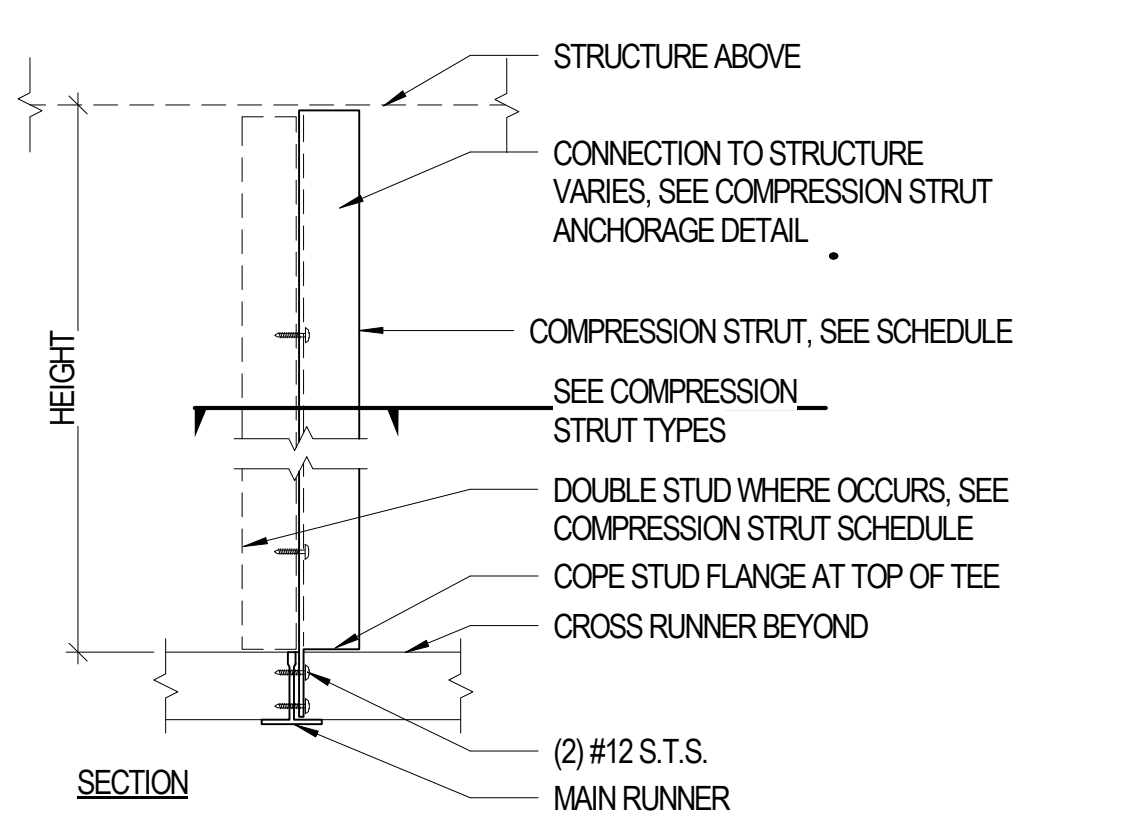

**C1 COMPRESSION STRUT**  
A701 3" = 1'-0"

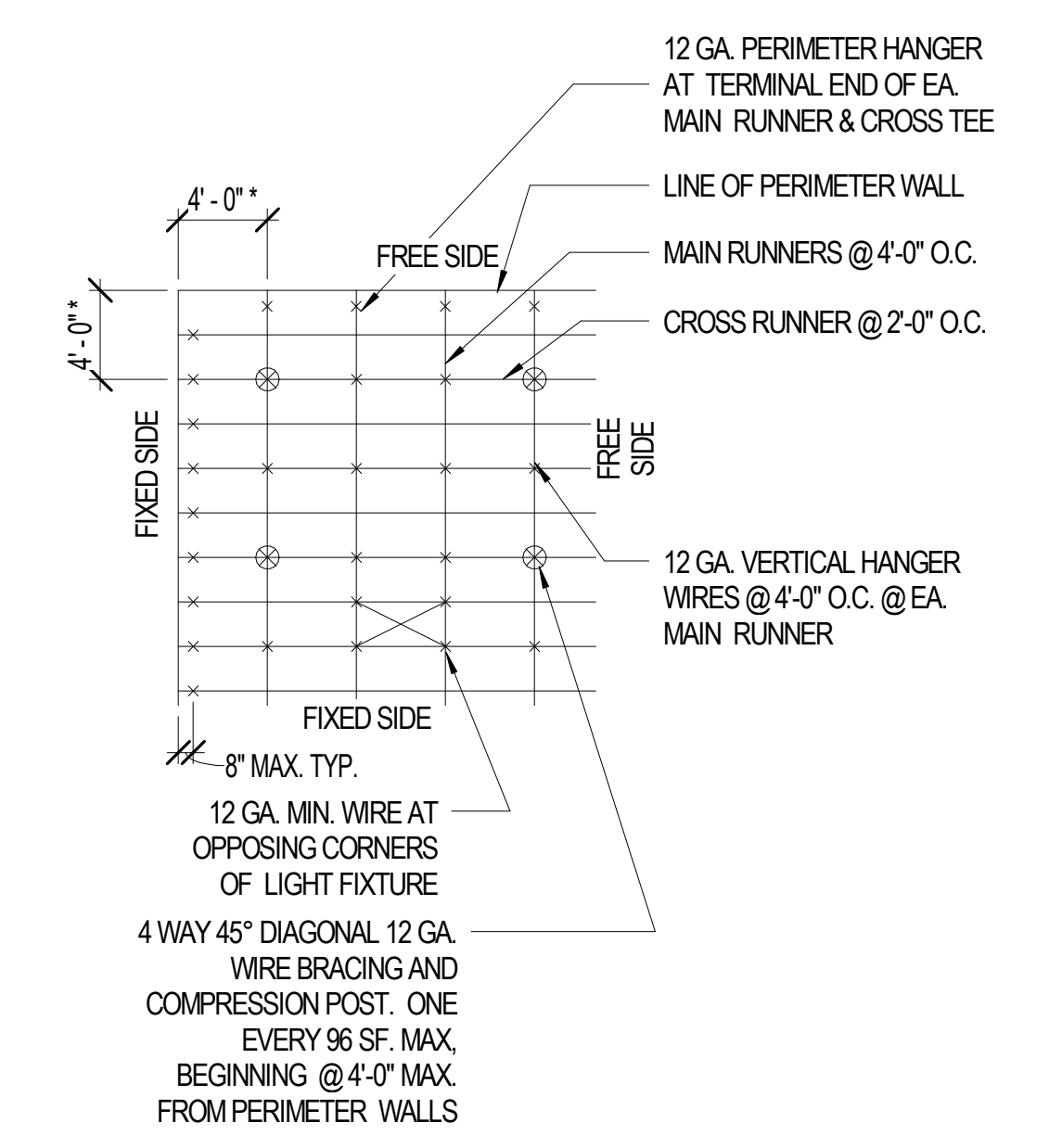

**A1 REQUIREMENTS**  
A701 1/8" = 1'-0"



**E5 A701 - CEILING DETAIL**  
A701 3" = 1'-0"

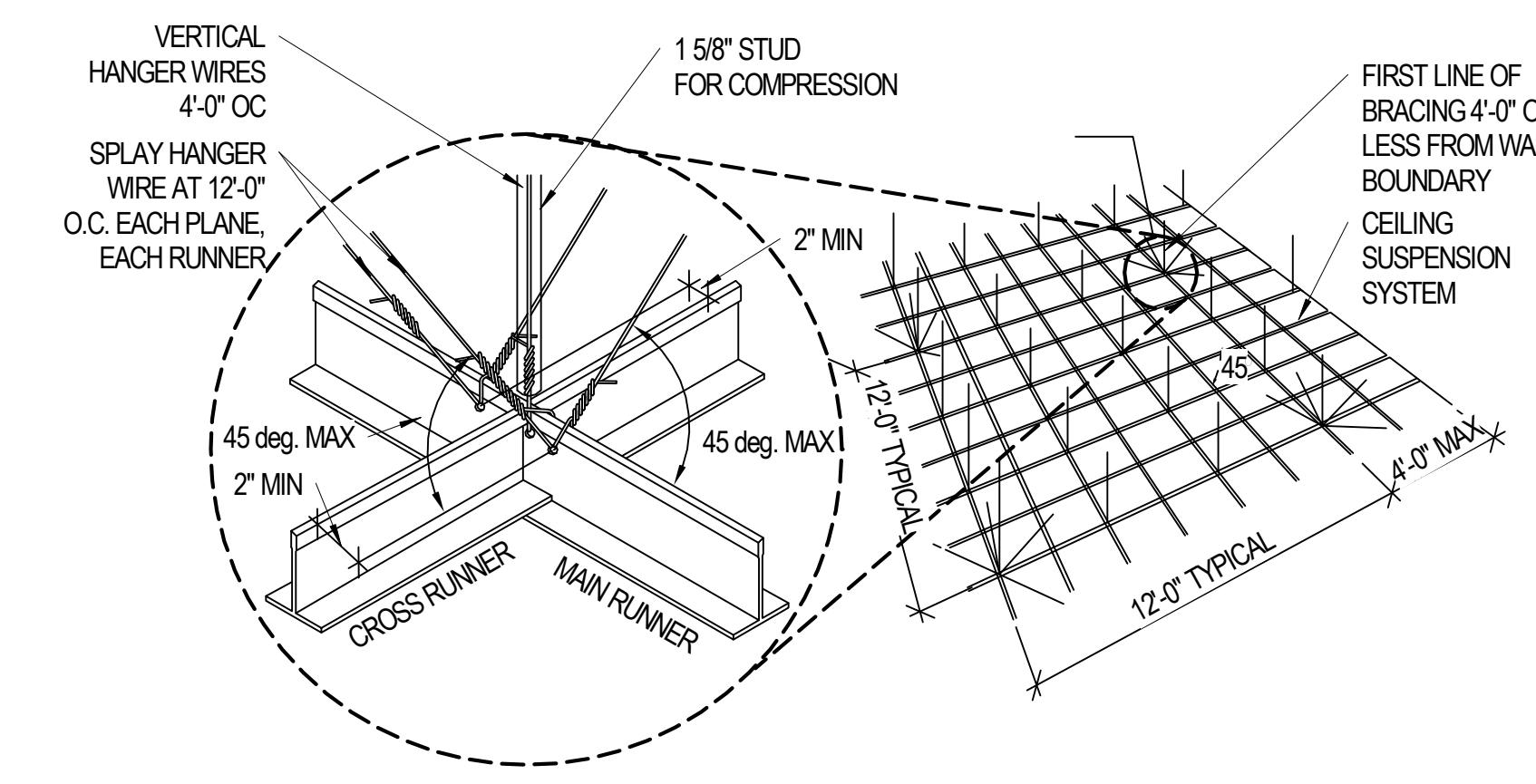

**D4 A701 - TYP. SEISMIC BRACING DETAIL**  
A701 3" = 1'-0"

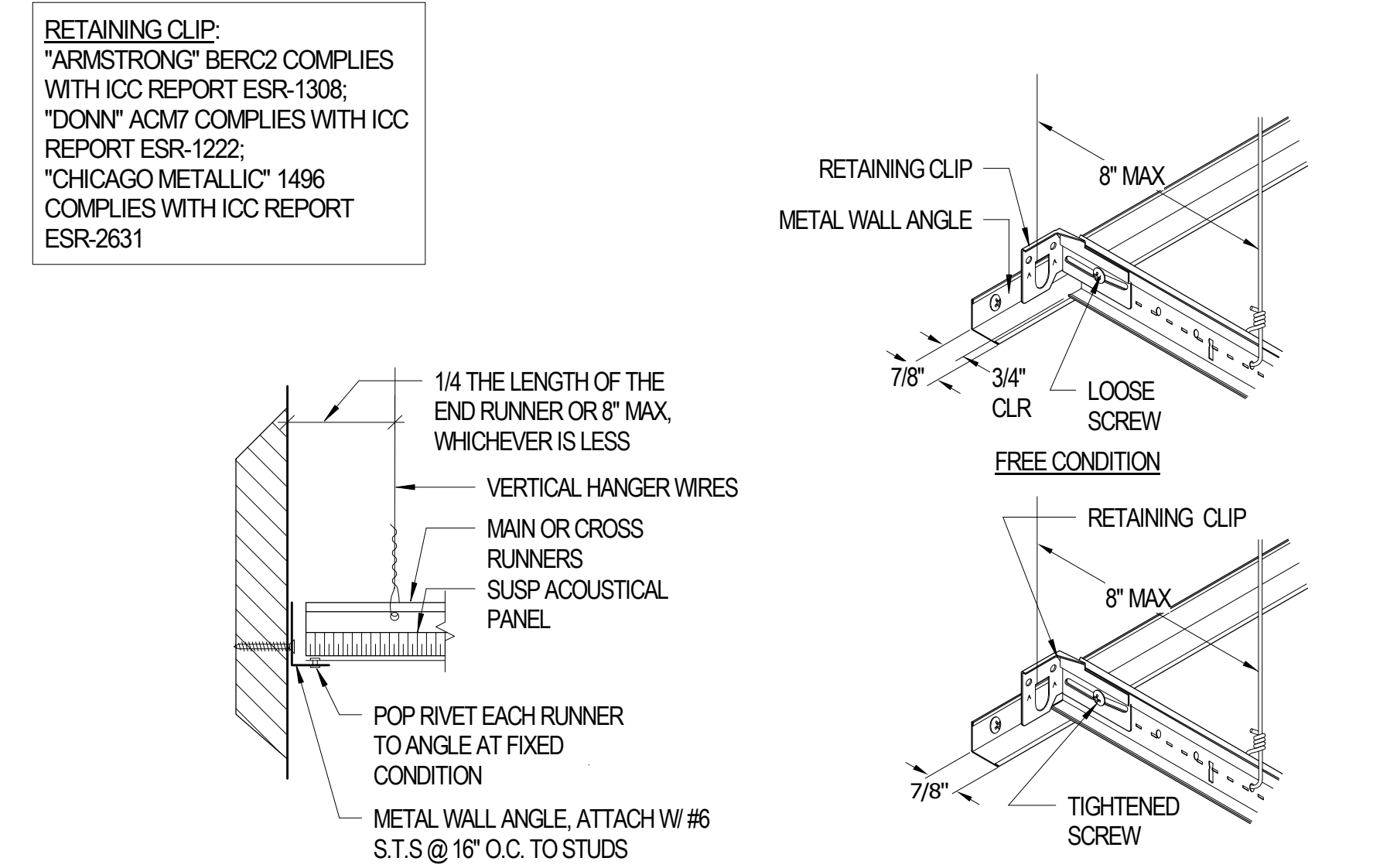

**SUSPENDED CEILING AT WALL**  
SCALE: 3" = 1'-0"

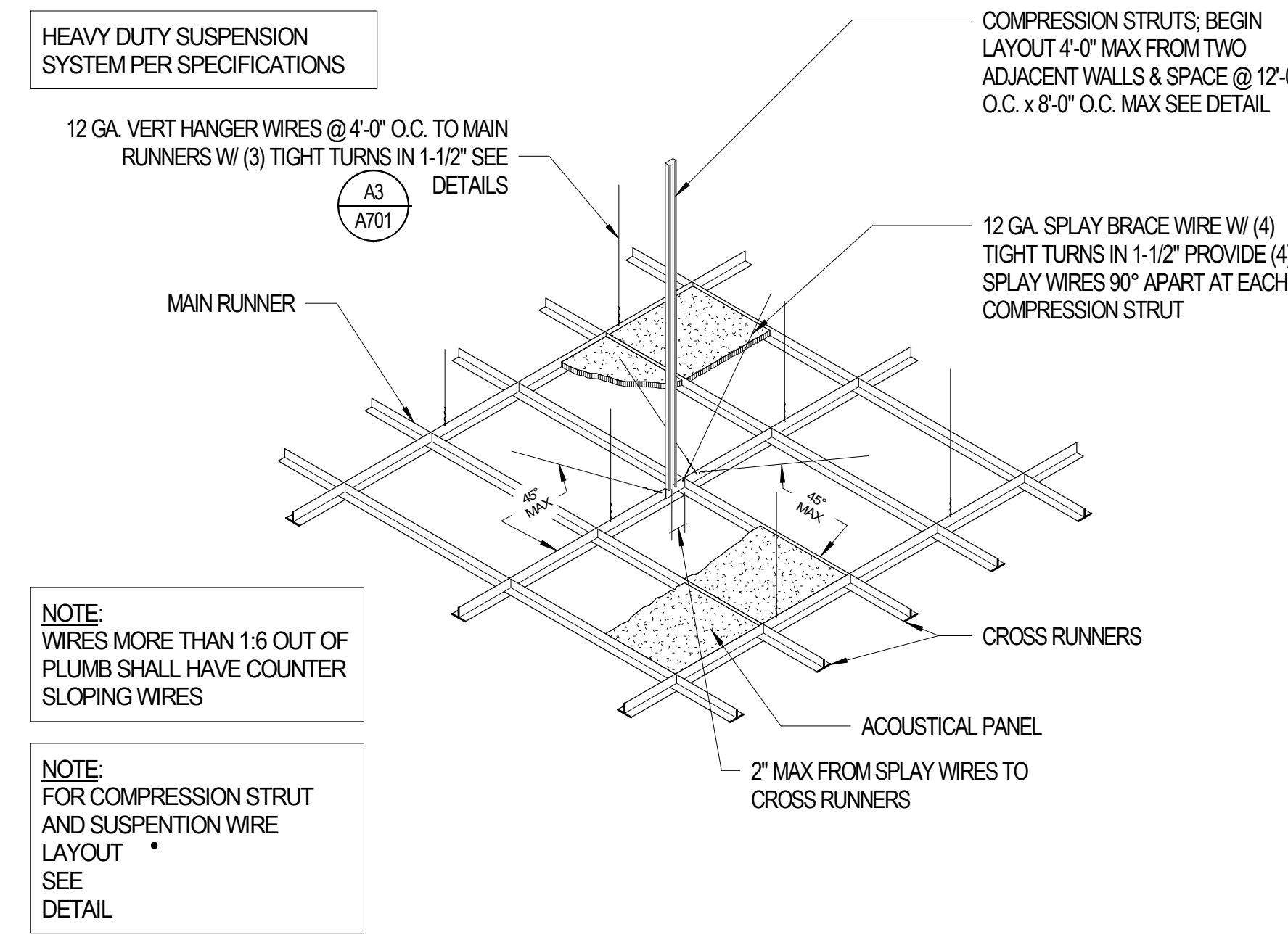

**SUSPENDED CEILING GRID**  
SCALE: 1/4" = 1'-0"

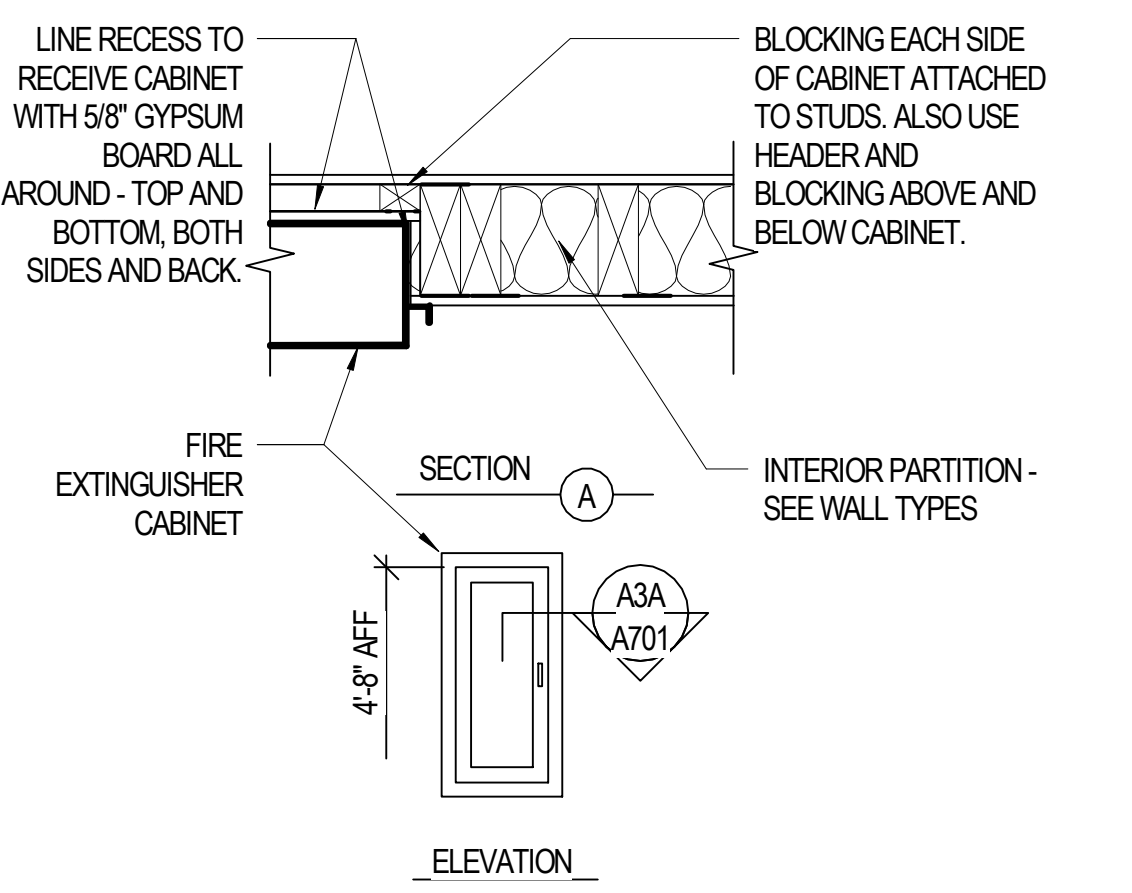

**C3 FIRE EXTINGUISHER CAB. DETAIL 02**  
A701 3" = 1'-0"

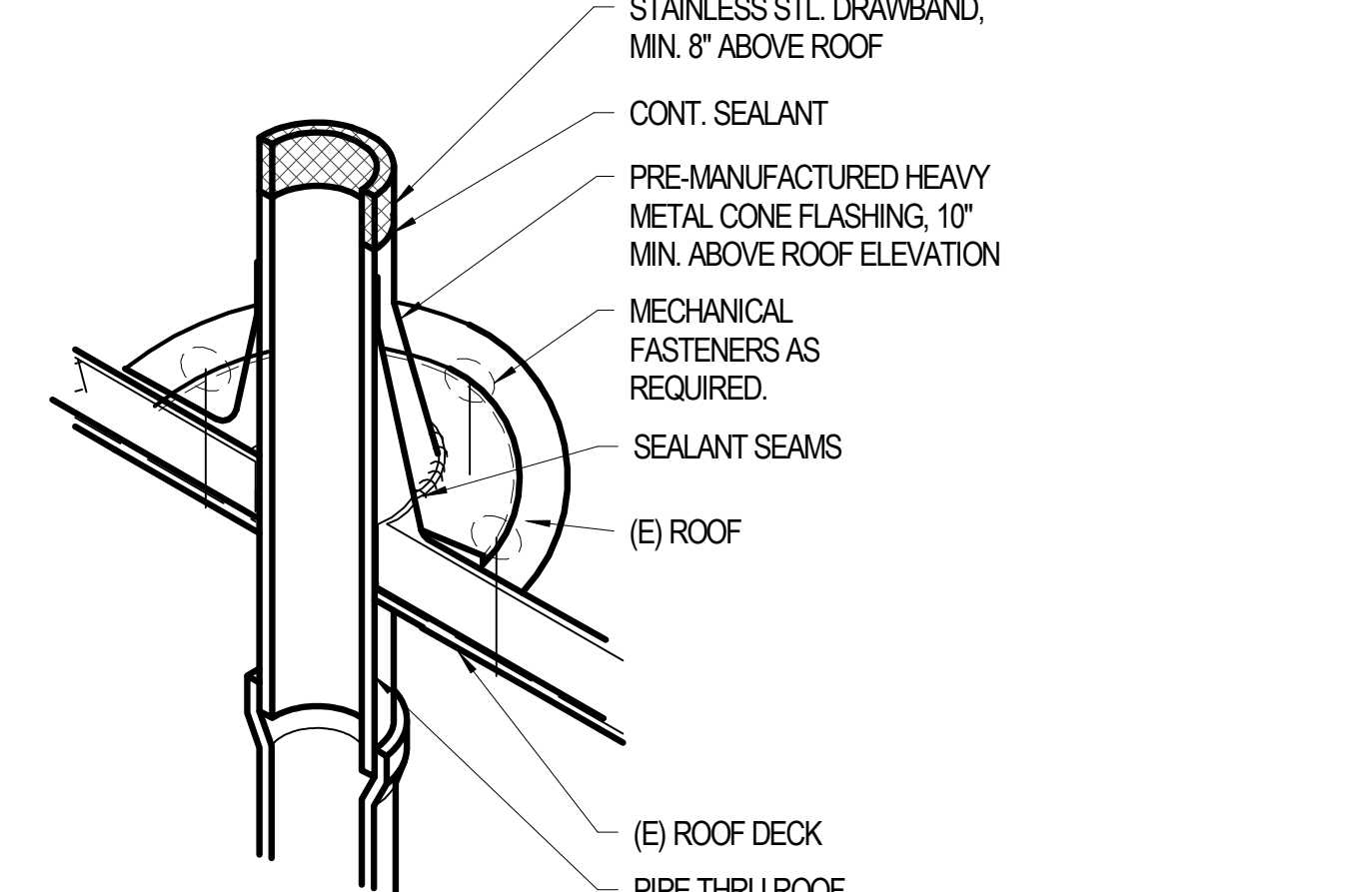

**C5 TYPICAL PIPE FLASHING DETAIL**  
A701 3" = 1'-0"

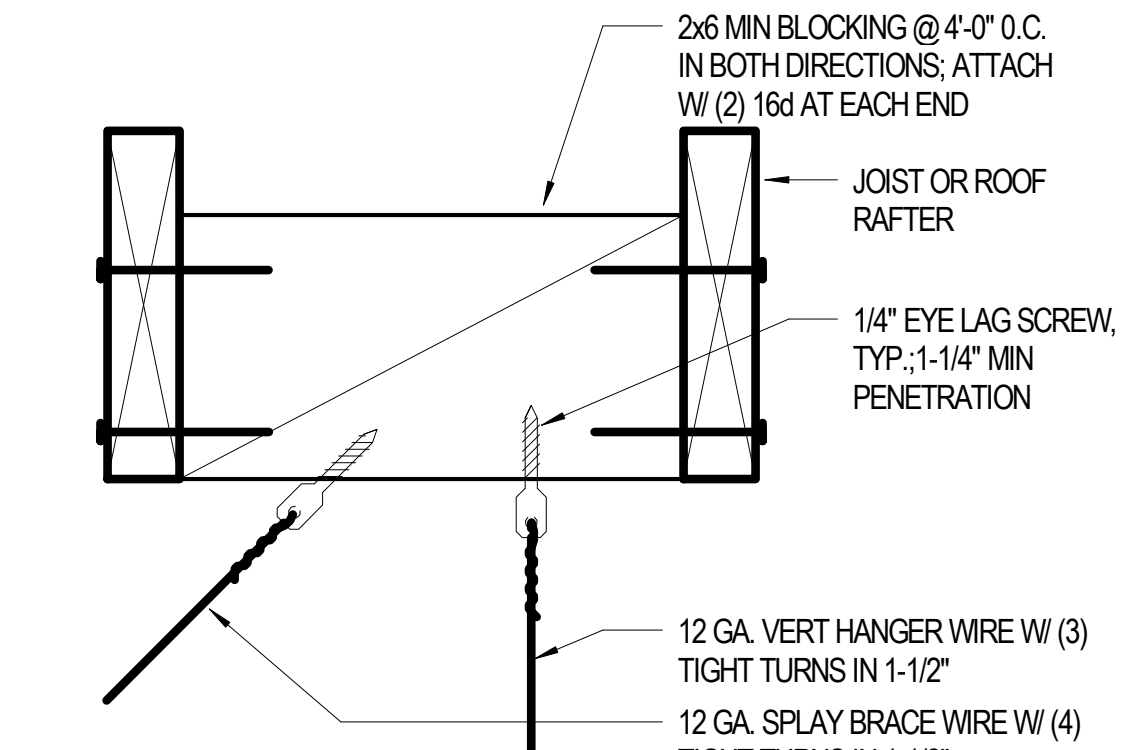

**C4 TYP SILL PLATE ATTACHMENT**  
A701 1 1/2" = 1'-0"

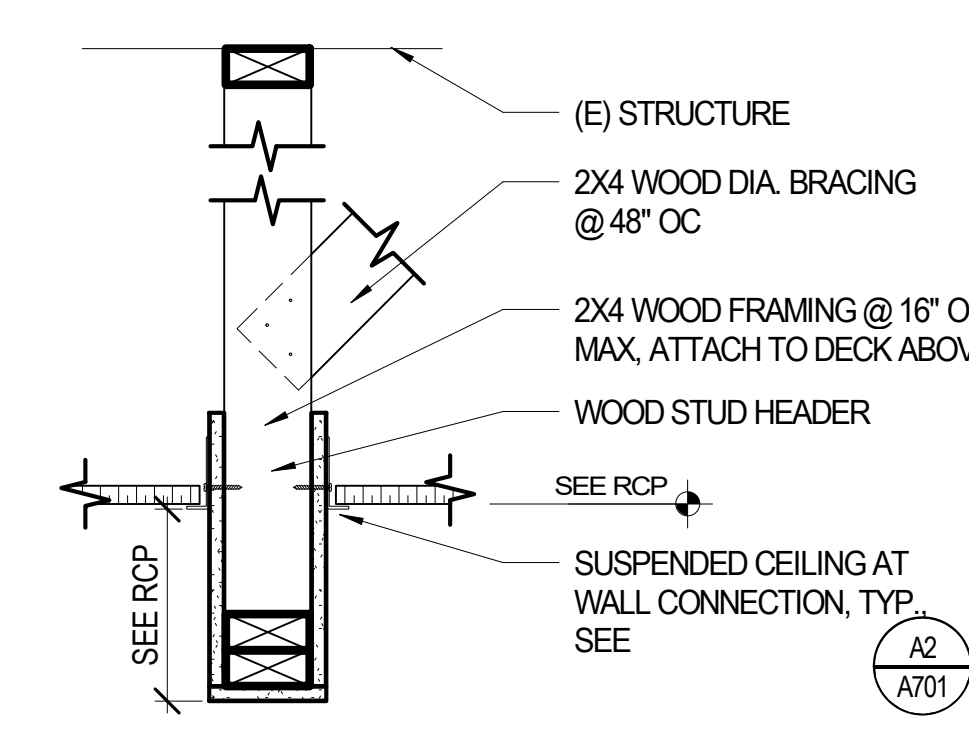

**B1 SOFFIT HEADER DETAIL**  
A701 1 1/2" = 1'-0"

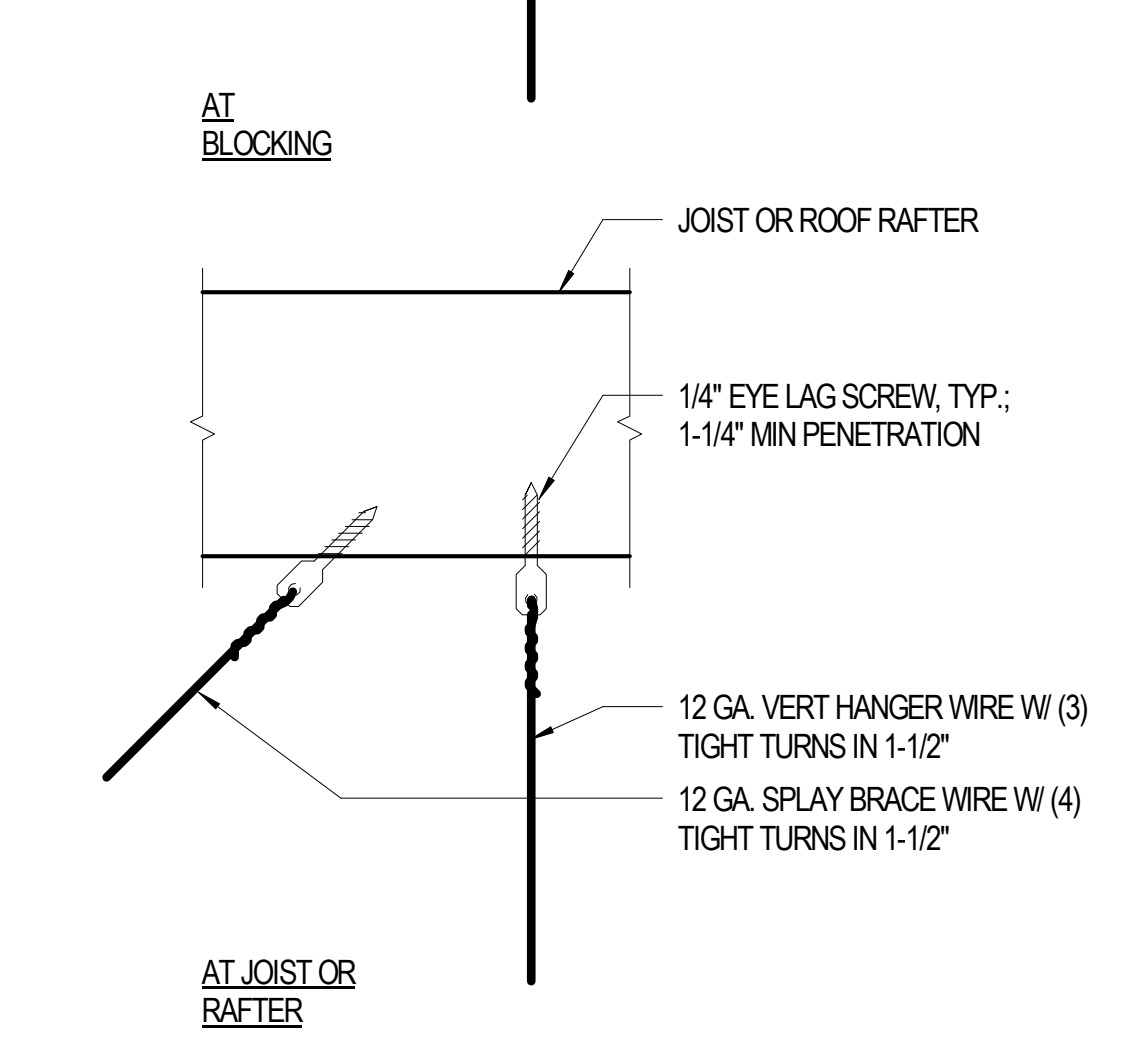

**A3 WIRE CONNECTION AT JOIST/RAFTER**  
A701 3" = 1'-0"

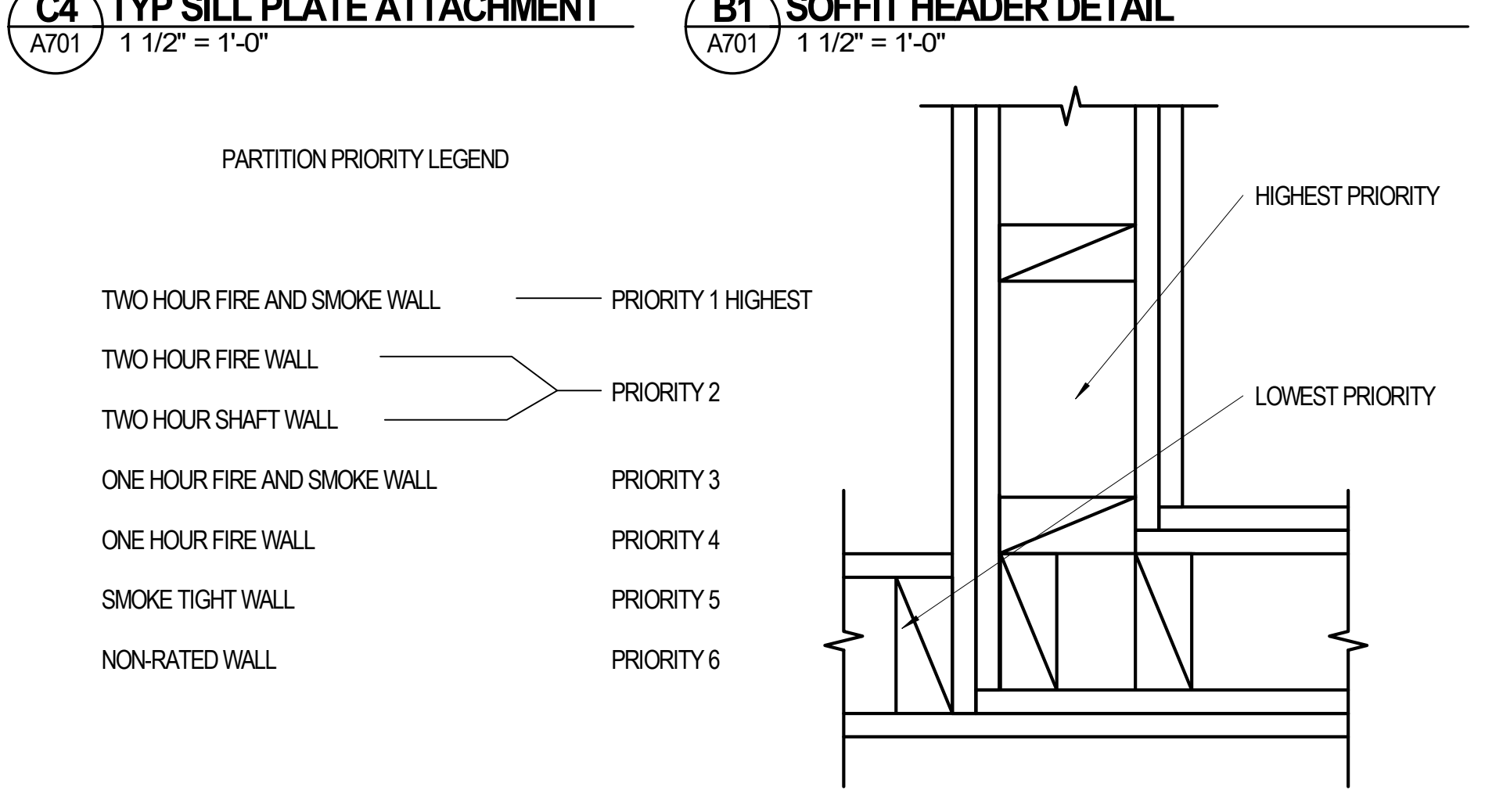

**A4 PARTITION PRIORITY LEGEND**  
A701 3" = 1'-0"

Revision table with columns for #, Date, and Revision.

**CONSTRUCTION DOCUMENTS**

NEXUS PROJ. #: 18117  
CHECKED BY: RP  
DRAWN BY: MR  
DATE: 01.02.2019

**TYPICAL DETAILS**

**A701**  
18-1912 Revised B 93 of 606  
BOS Rcvd 1-24-19

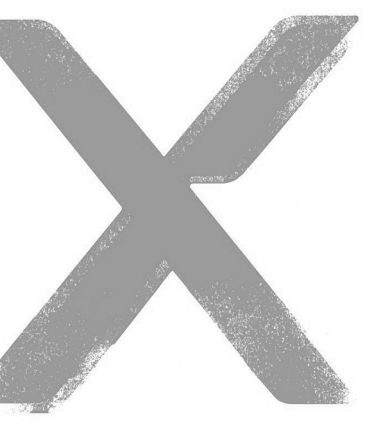

ARCH | NEXUS

Architectural NEXUS, Inc.  
930 R Street  
Sacramento, California 95811  
T 916.443.5911  
http://www.archnexus.com

Original drawings remain the property of the Architect and as such the Architect retains total ownership and control. The design represented by these drawings is sold to the client for a one time use, unless otherwise agreed upon in writing by the Architect. © Architectural Nexus, Inc. 2014



COUNTY OF EL DORADO  
**HHSA TENANT IMPROVEMENT**  
3368 SANDY WAY  
SOUTH LAKE TAHOE, CA 96150

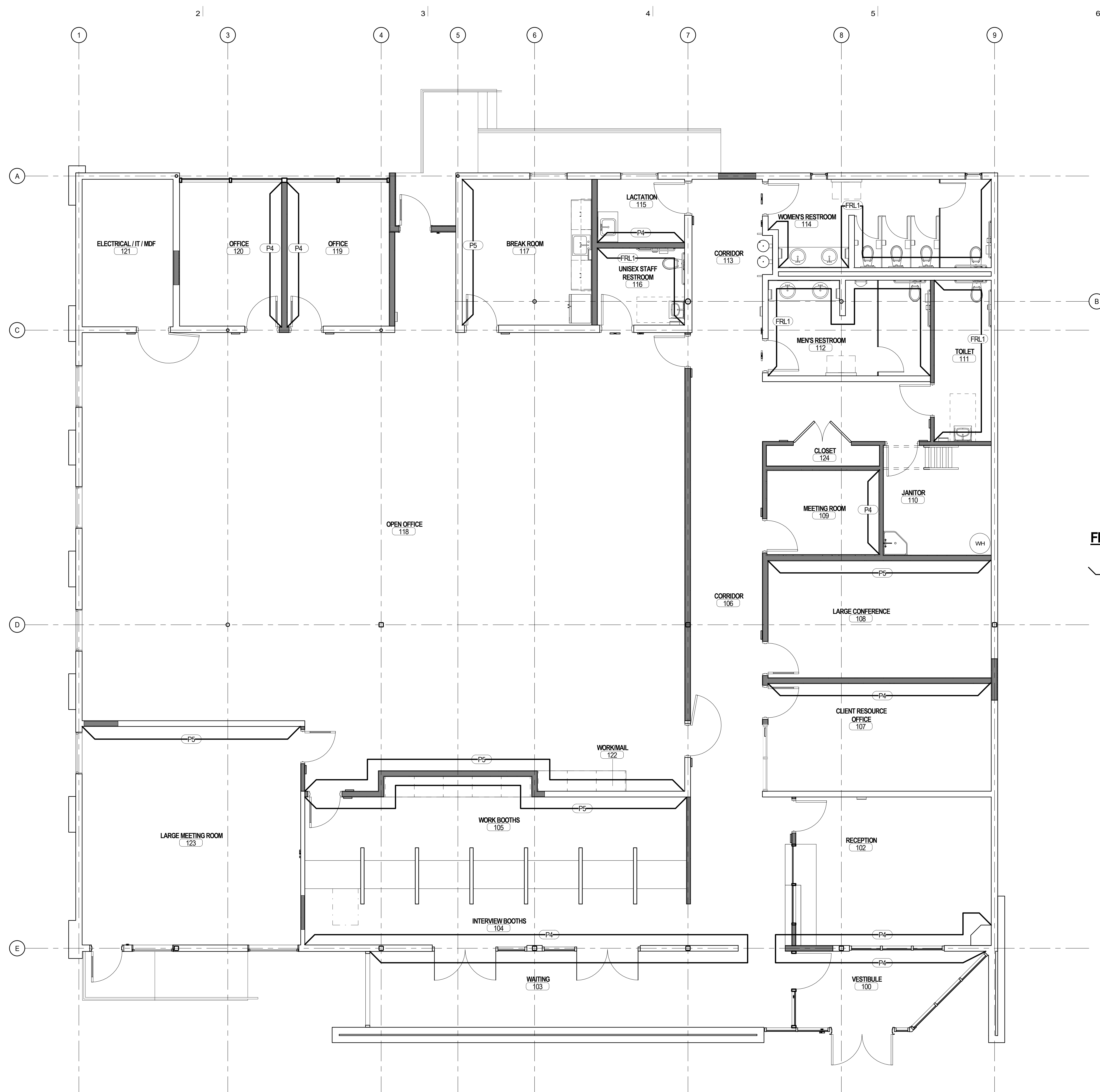

**FINISH PLAN LEGEND**

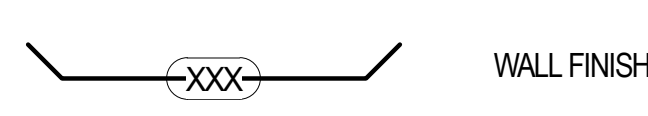

WALL FINISH

#	Date	Revision

**CONSTRUCTION DOCUMENTS**

NEXUS PROJ. #: 18117  
CHECKED BY: RP  
DRAWN BY: CJ  
DATE: 01.02.2019

**FINISH PLAN**

**A1 LEVEL 01 - FINISH FLOOR PLAN**  
1/4" = 1'-0"

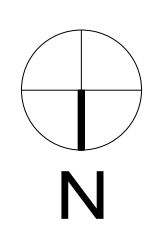

1/2/2019 4:37:02 PM

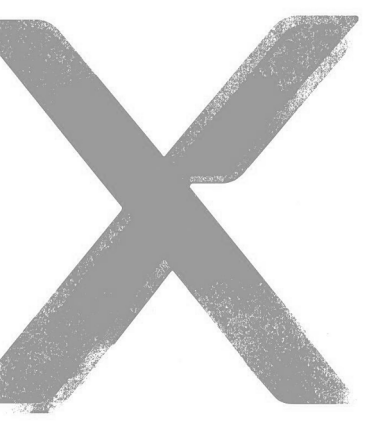

ARCH | NEXUS

Architectural NEXUS, Inc.  
930 R Street  
Sacramento, California 95811  
T 916.443.5911  
http://www.archnexus.com

Original drawings remain the property of the Architect and as such the Architect retains total ownership and control. The design represented by these drawings is sold to the client for a one time use, unless otherwise agreed upon in writing by the Architect. © Architectural Nexus, Inc. 2014



COUNTY OF EL DORADO  
**HHSA TENANT IMPROVEMENT**  
3368 SANDY WAY  
SOUTH LAKE TAHOE, CA 96150

# Date Revision

CONSTRUCTION DOCUMENTS

NEXUS PROJ. #: 18117  
CHECKED BY: RP  
DRAWN BY: CJ  
DATE: 01.02.2019

FINISH & FIXTURE SCHEDULES

AI602  
18-1912 Revised B 95 of 606  
BOS Revd 1-24-19

ROOM FINISH SCHEDULE									
Room	Name	Floor	Base	Walls			Ceiling Finish	Notes	
				N	E	S	W		
100	VESTIBULE	C2	B1	P1	P1	P4	P1	P3	
102	RECEPTION	C1	B1	P4	P1	P1	P1		OPEN CEILING WITH CLOUD CEILING
103	WAITING	C1	B1	P4	P1	P1	P1	P3	
104	INTERVIEW BOOTHS	C1	B1	P4	P1	P1	P1	1	PROVIDE 4" TRIM AT SUSPENDED CEILING CLOUDS
105	WORK BOOTHS	C1	B1	P1	P1	P5	P1		
106	CORRIDOR	C1	B1	P1	P1	P1	P1		
107	CLIENT RESOURCE OFFICE	C1	B1	P4	P1	P1	P1		
108	LARGE CONFERENCE	C1	B1	P1	P1	P5	P1		
109	MEETING ROOM	C1	B1	P1	P1	P1	P4		
110	JANITOR	SC	B1	P2/FRP1	P2/FRP1	P2/FRP1	P2/FRP1		SEE INTERIOR ELEVATIONS
111	TOILET	SVF1	B2	P2/FRL1	P2	P2/FRL1	P2/FRL1	P3	SEE INTERIOR ELEVATIONS
112	MEN'S RESTROOM	SVF1	B2	P2	P2/FRL1	P2/FRL1	P2/FRL1	P3	SEE INTERIOR ELEVATIONS
113	CORRIDOR	C1	B1	P1	P1	P1	P1		
114	WOMEN'S RESTROOM	SVF1	B2	P2	P2/FRL1	P2/FRL1	P2/FRL1	P3	SEE INTERIOR ELEVATIONS
115	LACTATION	SVF1	B1	P4	P1	P1	P1	P3	
116	UNISEX STAFF RESTROOM	SVF1	B2	P2	P2	P2/FRL1	P2/FRL1	P3	SEE INTERIOR ELEVATIONS
117	BREAK ROOM	SVF1	B1	P1	P5	P1	P1	P3	
118	OPEN OFFICE	C1	B1	P5	P1	P1	P1		
119	OFFICE	C1	B1	P1	P4	P1	P1		
120	OFFICE	C1	B1	P1	P1	P1	P4		
121	ELECTRICAL / IT / MDF	SC	B1	P1	PLY2	P1	P1		PLY2 TO BE INSTALLED ABOVE BASE, floor by EDC
122	WORK/MAIL	C1	B1	P1	P1	P4	P1		
123	LARGE MEETING ROOM	C1	B1	P1	P1	P5	P1		
124	CLOSET	C1	B1	P1	P1	P1	P1		

FINISH LEGEND			
MANUFACTURER	CODE	DESCRIPTION	REMARKS
<b>BASE FINISHES</b>			
JOHNSONITE	B1	4" RUBBER THERMOSET BASE, TSB-28-4, MEDIUM GRAY	
INTEGRAL COVE BASE	B2	6" INTEGRAL COVE BASE - TO BE WHERE SVF1 IS LOCATED	
<b>CEILING FINISHES</b>			
USG	CL1	2310, 2' x 4' ACOUSTICAL CEILING PANEL	
	CL2	FABRIC SCRIM, TO BE WHITE	OPEN OFFICE CEILING
	CL3	GYPSUM BOARD CEILING	
<b>FLOOR FINISHES</b>			
PATCRAFT	C1	10301 - VIM, 00523 - MOONGLOW, 24"x24" CARPET TILE	ECOWORK TILE BACKING, ASHLAR INSTALLATION, LOCK DOTS INSTALL SYSTEM
PATCRAFT	C2	10305 - ON THE RIGHT FOOT MODULAR - 00450 NAVY WALK-OFF MATT	ECOWORK TILE BACKING, QUARTER-TURN INSTALLATION
CUSTOME PATCRAFT	SC	SEAL EXPOSED EXISTING CONCRETE	WORK TO BE DONE BY OWNER
	SVF1	STYLE: 140V IVY WALK, SHEET VINLY FLOORING	CHEMICAL BOND AT SEAMS
<b>MILLWORK</b>			
WILSONART	PL1	MISSION MAPLE, 7990-38	CABINETRY VERTICAL PLASTIC LAMINATE
PIONITE	PL2	HEAD OVER HEELS AB300-SD	COUNTERTOPS AT INTERVIEW BOOTH & NON-SINK LOCATIONS, U.O.N.
MAPLE PLYWOOD	PLY1	MAPLE VENEER PLYWOOD, 4'X8 SHEETS, INSTALLED HORIZONTAL	FACE OF DESKS AT INTERVIEW BOOTHS & RECEPTION
WILSONART	SS1	ZEN GREY 9115GS SOLID SURFACE	RECEPTION TRANSACTION COUNTERS & SINK COUNTERS
<b>WALL FINISHES</b>			
ACOUSTIC FABRIC	AF1	TRIKES NUFELT FABRIC, COLOR TO BE SELECTED FROM MANUFACTURERS FULL RANGE	ACOUSTIC FABRIC AT INTERVIEW BOOTH WALLS
NEVAMAR	FRL1	FIBER REINFORCED LAMINATE, PENNY LANE NA190	RESTROOM WALL PROTECTION, 48" ABOVE INTEGRAL BASE
MARLITE	FRP1	FIBERGLASS REINFORCED PLASTIC, STANDARD FRP, PEBBLE SURFACE P100 WHITE	JANITOR CLOSET WALLS
SHERWIN WILLIAMS	P1	NAVAJO WHITE SW 6126 - EGG SHELL	FIELD PAINT
SHERWIN WILLIAMS	P2	NAVAJO WHITE SW 6126 - SEMI-GLOSS	RESTROOM FIELD PAINT
SHERWIN WILLIAMS	P3	CEILING BRIGHT WHITE SW 7007	GYPSUM BOARD CEILING PAINT
SHERWIN WILLIAMS	P4	AQUA-SPHERE SW 7613	ACCENT PAINT
SHERWIN WILLIAMS	P5	CARAMELIZED SW 9186	ACCENT PAINT
FIRE RATED PLYWOOD	PLY2	FIRE RATED PLYWOOD, 4X8 SHEETS	ELECTRICAL/MDF/IT BOARD, INSTALLED ABOVE BASE

**GENERAL NOTE - FINISH SCHEDULE**

- A. SEE REFLECTED CEILING PLANS FOR CEILING FEATURES AND INTERIOR ELEVATIONS FOR FINISH LOCATIONS AND DETAILS.
- B. SHEET VINYL FLOORING TO BE CHEMICALLY WELDED.
- C. INTERVIEW BOOTHS TO HAVE MAPLE PLYWOOD, PLY1, AT FACE OF STATIONS.
- D. FLOORING CONTRACTOR TO PROVIDE SEAMING DIAGRAM AND CARPET TILE PATTERN LAYOUT FOR APPROVAL PRIOR TO PURCHASE.
- E. PLEASE REFER TO SPECIFICATIONS FOR ADDITIONAL INFORMATION.
- F. SEE DEDUCT ALTERNATES #3 AND #4 FOR INFORMATION ON WHERE FINISHES WOULD BE REDUCED/REMOVED.

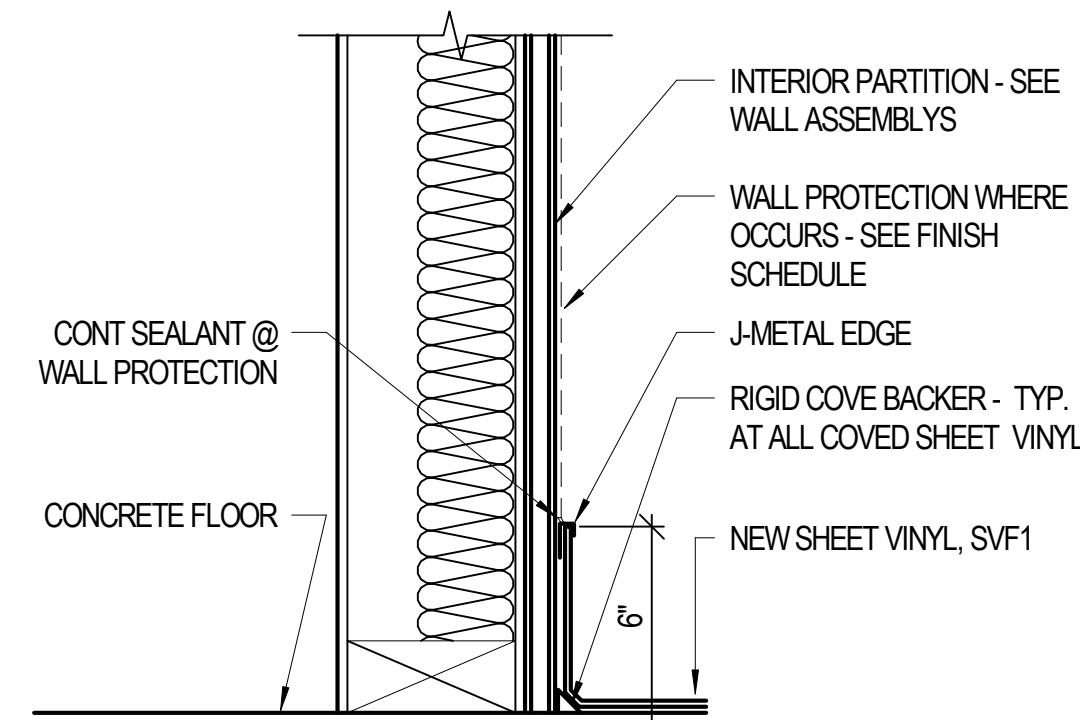

**1 INTEGRAL COVERED BASE DETAIL**  
AI602 3" = 1'-0"

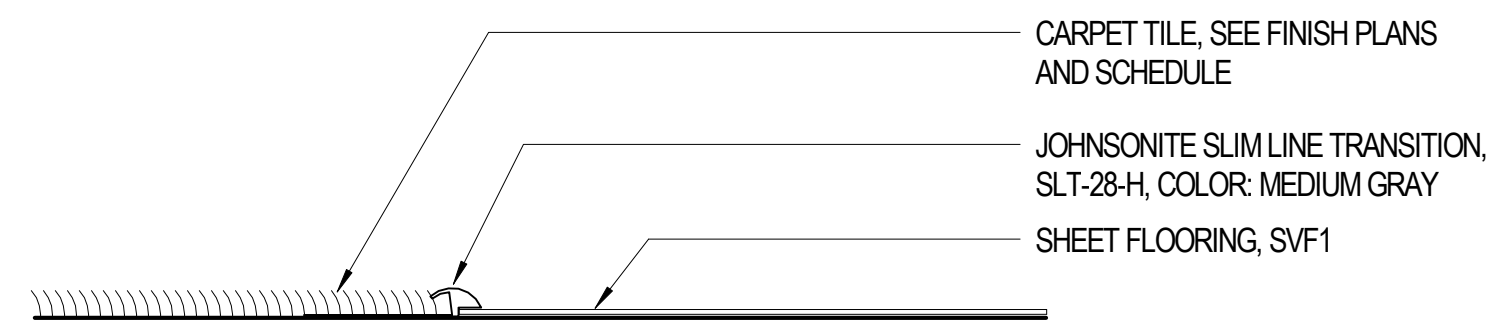

**2 CARPET TILE TO RESILIENT FLOORING TRANSITION**  
AI602 1 1/2" = 1'-0"

**EQUIPMENT & ACCESSORY SCHEDULE**

ITEM	MANUFACTURER	PRODUCT	KEYNOTE	QUANTITY	RESPONSIBILITY
EXTERIOR SECURITY CAMERA			28-SC1	3	CFCI
INTERIOR SECURITY CAMERA			28-SC2	7	CFCI
INTERIOR MEDIA CAMERA			28-SC3	1	CFCI
KEYCARD ACCESS			28-KC1	9	CFCI
LCD FLATPANEL SCREEN			26-TV1	1	CFCI
LCD FLATPANEL SCREEN			26-TV2	2	CFCI
MDF RACKS					SEE SPECIFICATIONS
MDF SWITCHES					CFCI
TOILET TISSUE DISPENSER	AMERICAN SPECIALTIES	0030, SURFACE MTD. TOILET TISSUE DISPENSER	10-TT1	7	CFCI
PAPER TOWEL DISPENSER	AMERICAN SPECIALTIES	0210, PAPER TOWEL DISPENSER	10-PT1	5	CFCI
LIQUID SOAP DISPENSER - WALL				7	CFCI
GRAB BAR (36")	AMERICAN SPECIALTIES	3801-36, 36" GRAB BAR	10-GB2	4	CFCI
GRAB BAR (42")	AMERICAN SPECIALTIES	3801-42, 42" GRAB BAR	10-GB1	4	CFCI
MIRROR, 24"X36"	AMERICAN SPECIALTIES	0620-2436, 24"X36" MIRROR	10-MR1	7	CFCI
SANITARY NAPKIN DISPOSAL	AMERICAN SPECIALTIES	0852, SURFACE MTD. DISPOSAL	10-SN1	5	CFCI
SEAT COVER DISPENSER	AMERICAN SPECIALTIES	0477-SM, SURFACE MTD.	10-SC1	7	CFCI
DRINKING FOUNTAIN GRAB BAR	BOBRICK	819236, 1-1/2" GRAB BAR	10-GB5	2	CFCI
UNDER LAVATORY PIPE GUARDS				7	CFCI
MOP & BROOM HOLDER	AMERICAN SPECIALTIES	1308-3, UTILITY SHELF & MOP STRIP, SURFACE MOUNTED		1	CFCI
BABY CHANGING STATION	AMERICAN SPECIALTIES	9013-9, SURFACE MTD.	10-BC1	2	CFCI
COAT CLOSET RACK	CUSTOM			1	CFCI
PORTABLE ASSISTED LISTENING SYSTEM				1	OFI
PANIC BUTTON	PROVIDED & INSTALLED BY SONITROL		28-PB1	11	CFCI

HVAC ABBREVIATIONS			
ABBREVIATION	DESCRIPTION	ABBREVIATION	DESCRIPTION
ABC	ABOVE CEILING	LBS	POUNDS
AC	AIR CONDITIONING	LDB	LEAVING DRY BULB
BHP	BRAKE HORSE POWER	LRA	LOCKED ROTOR AMPS
BTUH	BRITISH THERMAL UNITS PER HOUR	LWB	LEAVING WET BULB
CAP	CAPACITY	MAX	MAXIMUM
CD	CONDENSATE DRAIN	MBH	THOUSAND BTUs PER HOUR
CFH	CUBIC FEET OF GAS PER HOUR	MFR	MANUFACTURER
CFM	CUBIC FEET OF AIR FLOW PER MINUTE	(N)	NEW
CLG	CEILING	OA	OUTSIDE AIR
CONT	CONTINUATION	OC	ON CENTER
DIA	DIAMETER	OH	OVERHEAD
DTR	DOWN THROUGH ROOF	PD	PRESSURE DROP
(E)	EXISTING	PRV	PRESSURE REDUCING/REGULATING VALVE
EA	EXHAUST AIR	PSI (G) (A)	POUNDS PER SQUARE INCH (GAUGE) (ABSOLUTE)
EDB	ENTERING DRY BULB	PTAC	PACKAGED TERMINAL AIR CONDITIONER
EER	ENERGY EFFICIENCY RATING	RA	RETURN AIR
EF	EXHAUST FAN	RPM	REVOLUTIONS PER MINUTE
ESP	EXTERNAL STATIC PRESSURE	SA	SUPPLY AIR
EWB	ENTERING WET BULB	SAC	SPLIT AIR CONDITIONING
EWT	ENTERING WATER TEMPERATURE	SM	SHEET METAL
f	CUBIC FEET OF AIR FLOW PER MINUTE	SOV	SHUT OFF VALVE
F	DEGREES FAHRENHEIT	SP	STATIC PRESSURE
FA	FROM ABOVE	SPD	STATIC PRESSURE DROP
FB	FROM BELOW	SQ FT	SQUARE FEET
FLA	FULL LOAD AMPS	SQ IN	SQUARE INCHES
FT ( )	FOOT OR FEET	SS	STAINLESS STEEL
ft <sup>2</sup>	SQUARE FEET	STR	STRAINER
GPM	GALLONS PER MINUTE	TA	TO ABOVE
HP	HORSE POWER	TB	TO BELOW
HP	HEAT PUMP	TYP	TYPICAL
HW	HOT WATER	UON	UNLESS OTHERWISE NOTED
HHWR	HOT WATER RETURN	UTR	UP THROUGH ROOF
HHWS	HOT WATER SUPPLY	V (VTR)	VENT (VENT THROUGH ROOF)
IN. ( )	INCH	VVT	VARIABLE VOLUME & TEMPERATURE
IN <sup>2</sup>	SQUARE INCHES	WPD	WATER PRESSURE DROP FEET OF WATER COLUMN

DUCT LEGEND		
SINGLE LINE SYMBOL	DOUBLE LINE SYMBOL	DESCRIPTION
		RECTANGULAR DUCT, WIDTH x DEPTH (PLAN VIEW) DEPTH x WIDTH (SECTION VIEW)
		ACOUSTICALLY LINED RECTANGULAR DUCT - DIMENSIONS ARE OUTSIDE
		MANUAL AIR DAMPER
		RISE OR DROP DUCT IN DIRECTION OF AIR FLOW
		RECTANGULAR TO ROUND TRANSITION, MAX. SLOPE OF 1:3
		ROUND TO RECTANGULAR TRANSITION OR ROUND TO ROUND TRANSITION, MAX. SLOPE OF 1:3
		ELBOW, RECTANGULAR, SMOOTH RADIUS, WITHOUT TURNING VANES
		SQUARE/RECTANGULAR DUCT ELBOW WITH TURNING VANES
		CONVERGING OR DIVERGING TEE, 45° ENTRY, RECTANGULAR MAIN AND BRANCH, WHEN REDUCING MAIN, SIDE OF TAKE OFF OR ENTRY BRANCH TO BE FLAT, OTHER SIDES MAX. SLOPE OF 1:3
		ROUND DUCT TAKE OFF FROM RECTANGULAR VIA SMOOTH CONVERGING BELL MOUTH
		RECTANGULAR DUCT TEE, MAD'S ON THE 2 BRANCHES, THROAT SIZED FOR EQUAL PRESSURE DROP
		RECTANGULAR DUCT SPLIT, MAD'S, THROAT SIZED FOR EQUAL PRESSURE DROP
		3-WAY RECTANGULAR SPLIT WITH TWO TRANSITIONAL ELBOWS AND TRANSITIONING MAIN, DOWNSTREAM MAD'S OF THE TREE BRANCHES, THROATS SIZED FOR EQUAL PRESSURE DROP
		FOR CONCEALED DUCT, DROP TO DIFFUSER SHALL BE FULL SIZE OF DIFFUSER NECK, FOR EXPOSED DUCT, DROP SHALL BE FULL SIZE OF OD DIFFUSER FRAME, FLANGE FOR MOUNTING DIFFUSER TURNED IN, AIR EXTRACTOR AND EQUALIZER GRID AT CONNECTION TO MAIN.
		SUPPLY AIR, SUPPLY DROPRISE
		RETURN AIR, RETURN AIR DROPRISE
		EXHAUST AIR, EXHAUST AIR DROPRISE
		NEW - FLEXIBLE DUCT (ROUND)
		EXISTING - FLEXIBLE DUCT (ROUND)
		45° REDUCING LATERAL FITTING
		90° REDUCING TEE FITTING

CFM	DUCT SIZE (INCHES) ①			MIN. AREA (SQ. IN.) ②	REMARKS ③ ④
	ROUND	SQUARE	RECTANGULAR		
0-210	8"	8x8	8x8	48	8x8 MIN ON RA & EA
211-380	10"	10x10	10x8	80	
381-600	12"	12x12	12x10, 16x8	120	
601-900	14"	14x14	14x12, 18x10, 20x8	160	
901-1300	16"	16x16	16x14, 18x12, 22x10	220	
1301-1800	18"	18x18	18x16, 20x14, 22x12	264	
1801-2400	20"	20x20	22x16, 24x14, 30x12	340	

- NOTES:**
- SIZE OF BRANCH DUCT IF SHOWN ON PLANS OR FROM ABOVE TABLE IS NOT THE INLET SIZE TO DIFFUSER, GRILLE OR REGISTER, PROVIDE PLENUM BOX SEE NOTE ③
  - MINIMUM DUCT AREA TO BE USED FOR ALTERNATE DUCT SIZES (DIFFERENT THAN THIS TABLE) WHEN REQUESTED BY CONTRACTOR FOR SA, RA, AND EA.
  - SEE 6M550 FOR PLENUM BOX AT DIFFUSER/GRILLE AND FOR DETAIL OF DUCT BRANCH CONNECTION TO OUTLET (AND INLET) PLENUMS AT DIFFUSER/GRILLE.
  - ALL DUCT SIZES SHALL BE SHOWN CLEARLY ON THE CONTRACTOR'S SUBMITTAL DRAWINGS. SHOW SIZE OF EACH DUCT ON THE PLANS AT EACH DUCT LOCATION.

### MEP COMPONENT ANCHORAGE NOTE

ALL MECHANICAL, PLUMBING, AND ELECTRICAL COMPONENTS SHALL BE ANCHORED AND INSTALLED PER THE DETAILS ON THE APPROVED CONSTRUCTION DOCUMENTS. WHERE NO DETAIL IS INDICATED, THE FOLLOWING COMPONENTS SHALL BE ANCHORED OR BRACED TO MEET THE FORCE AND DISPLACEMENT REQUIREMENTS PRESCRIBED IN THE 2013 CBC, SECTIONS 1616A.1.18 THROUGH 1616A.1.26 AND ASCE 7-10 CHAPTER 13, 26 AND 30.

- ALL PERMANENT EQUIPMENT AND COMPONENTS.
- TEMPORARY OR MOVABLE EQUIPMENT THAT IS PERMANENTLY ATTACHED (e.g. HARD WIRED) TO THE BUILDING UTILITY SERVICES SUCH AS ELECTRICITY, GAS OR WATER.
- MOVABLE EQUIPMENT WHICH IS STATIONED IN ONE PLACE FOR MORE THAN 8 HOURS AND HEAVIER THAN 400 POUNDS OR HAS A CENTER OF MASS LOCATED 4 FEET OR MORE ABOVE THE ADJACENT FLOOR OR ROOF LEVEL THAT DIRECTLY SUPPORT THE COMPONENT ARE REQUIRED TO BE ANCHORED WITH TEMPORARY ATTACHMENTS.

THE FOLLOWING MECHANICAL AND ELECTRICAL COMPONENTS SHALL BE POSITIVELY ATTACHED TO THE STRUCTURE, BUT THE ATTACHMENT NEED NOT BE DETAILED ON THE PLANS. THESE COMPONENTS SHALL HAVE FLEXIBLE CONNECTIONS PROVIDED BETWEEN THE COMPONENT AND ASSOCIATED DUCTWORK, PIPING, AND CONDUIT.

- COMPONENTS WEIGHING LESS THAN 400 POUNDS AND HAVE A CENTER OF MASS LOCATED 4 FEET OR LESS ABOVE THE ADJACENT FLOOR OR ROOF LEVEL THAT DIRECTLY SUPPORT THE COMPONENT.
- COMPONENTS WEIGHING LESS THAN 20 POUNDS, OR IN THE CASE OF DISTRIBUTION SYSTEMS, LESS THAN 5 POUNDS PER FOOT, WHICH ARE SUSPENDED FROM A ROOF OR FLOOR OR HUNG FROM A WALL.

FOR THOSE ELEMENTS THAT DO NOT REQUIRE DETAILS ON THE APPROVED DRAWINGS, THE INSTALLATION SHALL BE SUBJECT TO THE APPROVAL OF THE DESIGN PROFESSIONAL IN GENERAL RESPONSIBLE CHARGE OR STRUCTURAL ENGINEER DELEGATED RESPONSIBILITY. THE PROJECT INSPECTOR WILL VERIFY THAT ALL COMPONENTS AND EQUIPMENT HAVE BEEN ANCHORED IN ACCORDANCE WITH ABOVE REQUIREMENTS.

### PIPING, DUCTWORK & ELECTRICAL DISTRIBUTION SYSTEM BRACING NOTE

PIPING, DUCTWORK, AND ELECTRICAL DISTRIBUTION SYSTEMS SHALL BE BRACED TO COMPLY WITH THE FORCES AND DISPLACEMENTS PRESCRIBED IN ASCE 7-10 SECTION 13.3 AS DEFINED IN ASCE 7-10 SECTION 13.6.5.6, 13.6.7, 13.6.8, AND 2016 CBC, SECTIONS 1616A.1.23, 1616A.1.24, 1616A.1.25 AND 1616A.1.26.

THE METHOD OF SHOWING BRACING AND ATTACHMENTS TO THE STRUCTURE FOR THE IDENTIFIED DISTRIBUTION SYSTEM ARE AS NOTED BELOW. WHEN BRACING AND ATTACHMENTS ARE BASED ON PREAPPROVED INSTALLATION GUIDE (e.g. SMACNA OR OSHPD OPM), COPIES OF THE BRACING SYSTEM INSTALLATION GUIDE OR MANUAL SHALL BE AVAILABLE ON THE JOBSITE PRIOR TO THE START OF AND DURING THE HANGING AND BRACING OF THE DISTRIBUTION SYSTEMS. THE STRUCTURAL ENGINEER OF RECORD SHALL VERIFY THE ADEQUACY OF THE STRUCTURE TO SUPPORT THE HANGER AND BRACE LOADS.

MECHANICAL PIPING (MP), MECHANICAL DUCTS (MD), PLUMBING PIPING (PP), ELECTRICAL DISTRIBUTION SYSTEMS (E):

MP  MD  PP  E  OPTION 1: DETAILED ON THE APPROVED DRAWINGS WITH PROJECT SPECIFIC NOTES AND DETAILS

MP  MD  PP  E  OPTION 2: SHALL COMPLY WITH THE APPLICABLE OSHPD PRE-APPROVED (OPM #) \_\_\_\_\_

MP  MD  PP  E  OPTION 3: SHALL COMPLY WITH THE SMACNA SEISMIC RESTRAINT MANUAL, OSHPD EDITION (2009), INCLUDING ANY ADDENDA, FASTENERS AND OTHER ATTACHMENTS NOT SPECIFICALLY IDENTIFIED IN THE SMACNA SEISMIC RESTRAINT MANUAL, OSHPD EDITION, ARE DETAILED ON THE APPROVED DRAWINGS WITH PROJECT SPECIFIC NOTES AND DETAILS. THE DETAILS SHALL ACCOUNT FOR THE APPLICABLE SEISMIC HAZARD LEVEL \_\_\_\_\_ AND CONNECTION LEVEL \_\_\_\_\_ FOR THE PROJECT AND CONDITIONS.

SYMBOLS LEGEND		
SYMBOL	ABBREVIATION	DESCRIPTION
	--	3 WAY MODULATING CONTROL VALVE
	--	3 WAY TWO POSITION CONTROL VALVE
	--	3 WAY VALVE
	--	ANCHOR
	--	ANGLE GLOBE VALVE
	AVN	ANGLE VALVE
	AQ	AQUASTAT
	AD	AREA DRAIN
	--	AUTOMATIC AIR VENT
	--	AUTOMATIC FLOW CONTROL
	BFP, BP, DCW	BACKFLOW PREVENTER, REDUCE PRESSURE, DOUBLE CHECKVALVE
	--	BALANCING VALVE
	--	BALL JOINT
	--	BALL VALVE
	--	BOTTOM CONNECTION
	--	BUTTERFLY VALVE
	BPT	BYPASS TIMER
	CBV	CALIBRATED BALANCE VALVE
	CB, RD	CATCH BASIN, ROOF DRAIN
	--	CHECK VALVE
	--	CIRCUIT SETTER VALVE
	CP	CIRCULATING PUMP
	CO	CLEANOUT
	CO2	CO2 SENSOR
	--	ECCENTRIC REDUCER
	EJ	EXPANSION JOINT
	FD	FIRE DAMPER
	FDC	FIRE DEPARTMENT CONNECTION
	FHC	FIRE HOSE RACK AND CABINET
	FH	FIRE HYDRANT
	FS	FIRE/SMOKE DAMPER
	--	FLEXIBLE CONNECTOR
	--	FLOAT & THERMOSTATIC TRAP
	FD	FLOOR DRAIN
	FS	FLOOR SINK
	--	FLOW ARROW
	FE	FLOW ELEMENT
	FLV	FLOW LIMITING VALVE
	FS	FLOW SWITCH
	GCK	GAGE COCK

HVAC SYSTEMS LEGEND		
SYMBOL	ABBREVIATION	DESCRIPTION
	EA	EXHAUST AIR
	OA	OUTSIDE AIR
	RA	RETURN AIR
	SA	SUPPLY AIR

HVAC DESIGN DATA		
	DRY BULB (F)	WET BULB (F)
SUMMER	85	56
WINTER	-2	--
	COOLING SET POINT (F)	HEATING SET POINT (F)
INDOOR	75	70

SYMBOLS LEGEND		
SYMBOL	ABBREVIATION	DESCRIPTION
	GSCX, PC	GAS COCK, PLUG COCK
	GM	GAS METER
	GPR	GAS PRESSURE REGULATOR
	--	GATE VALVE WITH HOSE ADAPTER
	--	GATE VALVE
	--	GLOBE VALVE
	HD	HOPPER DRAIN
	HB	HOSE BIBB
	HB	HOSE BIBB
	H	HUMIDISTAT
	--	INVERTED BUCKET TRAP
	--	LIMIT OF DEMOLITION
	--	MANUAL AIR VENT
	--	MODULATING CONTROL VALVE
	--	PIPE BREAK
	--	PIPE CAP
	--	PIPE DOWN
	--	PIPE GUIDE
	--	PIPE UP
	--	POINT OF CONNECTION
	PIV	POST INDICATOR VALVE
	PRV	PRESSURE REGULATING VALVE
	--	PRESSURE RELIEF VALVE
	--	REDUCER
	SD	SMOKE DAMPER
	SKD	SMOKE DETECTOR
	--	SOLENOID VALVE
	--	STRAINER
	TS	TEMPERATURE SENSOR
	--	TEST PLUG
	--	THERMOMETER
	T	THERMOSTAT
	TP	TRAP PRIMER
	--	TWO POSITION CONTROL VALVE
	--	UNION
	--	VALVE IN RISER/DROP
	VB	VALVE IN VALVE BOX
	--	WALL CLEANOUT
	WHA	WATER HAMMER ARRESTOR
	WM	WATER METER

### MECHANICAL GENERAL NOTES

- ALL WORK SHALL COMPLY WITH ALL APPLICABLE CODES, SPECIFICATIONS, LOCAL ORDINANCES, AND INDUSTRY STANDARDS.
- VERIFY EXACT LOCATION OF ALL (E) EQUIPMENT, DUCTWORK, DIFFUSERS, REGISTERS, AND GRILLES. NOTIFY ARCHITECT IMMEDIATELY OF ANY DISCREPANCIES BETWEEN (E) SYSTEMS AND DRAWINGS.
- COORDINATE EXACT LOCATION OF EQUIPMENT AND ALL PENETRATIONS THROUGH ROOF, FLOORS, AND WALLS WITH ARCHITECTURAL STRUCTURAL SYSTEMS PRIOR TO COMMENCING WORK.
- COORDINATE EXACT SIZE AND ROUTING OF DUCTWORK WITH ARCHITECTURAL PLANS, STRUCTURE, AND EQUIPMENT PRIOR TO COMMENCING WORK.
- SEE ARCHITECTURAL REFLECTED CEILING PLAN FOR EXACT LOCATION OF ALL CEILING DIFFUSERS, REGISTERS, AND GRILLES.
- FURNISH AND INSTALL MANUAL AIR DAMPERS AT ALL DUCT BRANCH TAKEOFFS TO A SINGLE SUPPLY DIFFUSER.
- FLEXIBLE DUCTWORK CONNECTIONS TO CEILING DIFFUSERS ARE LIMITED TO 5' MAXIMUM LENGTH.
- ALL DUCTWORK, CEILING DIFFUSERS/REGISTERS/GRILLES, EQUIPMENT, PIPING, ETC. ARE NEW UNLESS OTHERWISE NOTED (E) DUCTWORK AND P.O.C.'S SHOWN, ALL OTHER (E) DUCTWORK, ETC. TO REMAIN.
- (E) DUCTWORK AND ITEMS TO BE REMOVED ARE SHOWN CROSSED ("X") OUT. SEE LEGEND. COORDINATE CLOSELY WITH (N) DUCTWORK AND P.O.C.'S SHOWN. ALL OTHER (E) DUCTWORK, ETC. TO REMAIN.
- WHERE INLET DUCT DIAMETER AND DIFFUSER NECK SIZE ARE THE SAME (I.E. 6" AND 6x6) CONTRACTOR SHALL OVERSIZE THE SHEET METAL PLENUM TO ACCOMMODATE THE ROUND DUCT CONNECTION.

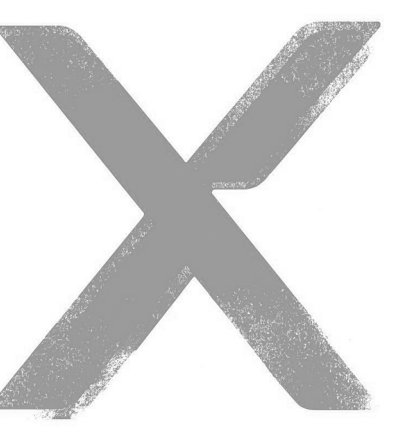

ARCH | NEXUS  
 Architectural NEXUS, Inc.  
 930 R Street  
 Sacramento, California 95811  
 T 916.443.5911  
 http://www.archnexus.com

Original drawings remain the property of the Architect and as such the Architect retains total ownership and control. The design represented by these drawings is sold to the client for a one time use, unless otherwise agreed upon in writing by the Architect. © Architectural Nexus, Inc. 2014

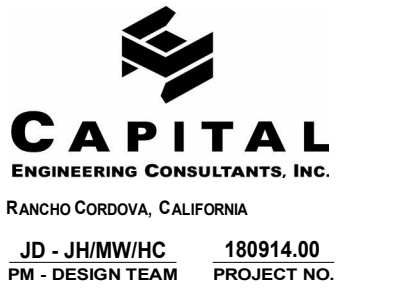

EL DORADO COUNTY  
**EDC HHS TENANT IMPROVEMENT**  
 3368 SANDY WAY  
 SOUTH LAKE TAHOE, CA 96150



DATE SIGNED: 1-02-19  
 # Date Revision

**CONSTRUCTION DOCUMENTS**

NEXUS PROJ. #: 18117  
 CHECKED BY: Checker  
 DRAWN BY: Author  
 DATE: 01.02.2019

**HVAC LEGENDS AND NOTES**



### AC UNIT SCHEDULE

EQUIPMENT TAG		LOCATION	MANUFACTURER	MODEL	CFM	DESIGN O.A. [CFM]	ESP [IN. W.G.]	SENS. COOLING CAP. [MBH]	TOTAL COOLING CAP. [MBH]	EVAP.		GAS HEATING			AC UNIT ELECTRICAL DATA										PWR. EXH. ECON. ELECTRICAL DATA					SEER [EER]	OPER. WT. [LBS.]	MOUNTING DETAIL	NOTES
TYPE	UNIT #									EDB [F]	EWB [F]	INPUT [MBH]	OUTPUT [MBH]	AFUE [%]	VOLT	PHASE	SUPPLY FAN BHP	QTY	RLA	MCA	MOCP [AMPS]	COND. FAN FLA	CFM	SP	FLA	MCA	MOCP						
AC	1	ROOF	TRANE	YHC067E3RHA	1800	575	0.8	39.4	51.6	78.2	58.7	130	104.0	80	230	3	0.59	1	16.2	31.7	45	2	1800	0.5	3.1	3.9	10	17.2	1500	4/M500	1,2,3,4		
AC	2	ROOF	TRANE	YHC067E3RHA	2250	875	0.8	51.6	53.8	79.2	58.3	130	104.0	80	230	3	0.74	1	16.2	31.7	45	2	2250	0.5	3.1	3.9	10	17.2	1500	4/M500	1,2,3,4		
AC	3	ROOF	TRANE	YHC037E3RHA	1440	650	0.8	32.1	33.4	79.3	58.3	100	80.0	80	230	3	0.54	1	11.6	23.3	30	1.5	1440	0.5	3.1	3.9	10	17.5	1200	4/M500	1,2,3,4		

- NOTES:
- PROVIDE CUSTOM ROOF ADAPTER CURB. WEIGHT OF ADAPTER CURB IS APPROXIMATELY 250LB.
  - AIR MOVING SYSTEMS THAT CUMULATIVELY SUPPLY AIR IN EXCESS OF 2,000 CUBIC FEET PER MINUTE TO ENCLOSED SPACES WITHIN BUILDINGS SHALL BE EQUIPPED WITH AUTOMATIC SHUTOFF BY SMOKE DETECTOR. HVAC SHUTDOWN SHALL BE TESTED IN THE PRESENCE OF THE FIRE INSPECTOR (2016 CMIC 608.1).
  - PROVIDE UNIT WITH "MICROMETL" 100% MODULATING POWER EXHAUST ECONOMIZER WITH VFD, STATIC PRESSURE TRANSMITTER, "BELIMO" LF SERIES ACTUATORS. PROVIDE SEPARATE POWER CONNECTIONS, APPROPRIATE CIRCUIT BREAKER(S), FEEDER(S), AND DISCONNECT(S) AS REQUIRED BY CODE.
  - PROVIDE UNIT WITH MERV-8 FILTERS.

### FAN SCHEDULE

EQUIPMENT TAG		LOCATION	"MFR" MODEL NO.	CFM	SP [IN. W.G.]	RPM	BHP	HP	PHASE	VOLT	OPER. WT. [LBS.]	MOUNTING DETAIL	NOTES
TYPE	UNIT #												
EF	1	ROOF	"GREENHECK" CUE-099-VG	575	0.50	1347	0.09	1/4	1	115	85	1/M500	1,2

- NOTES:
- PROVIDE WITH MANUFACTURER'S 20" INSULATED ROOF CURB.
  - INTERLOCK FAN WITH AC-3.

### SPLIT SYSTEM INDOOR UNIT SCHEDULE

EQUIPMENT TAG		MANUFACTURER	MODEL	LOCATION	TYPE	FAN AIR FLOW [CFM]	COOLING CAPACITY [BTUH]	HEATING CAPACITY [BTUH]	FILTER [MERV RATING]	MOUNTING DETAIL	OPERATING WEIGHT [LB]	NOTES
TYPE	UNIT #											
SHP	1	mitsubishi	PKA-A24KA7	121 - ELECTRICAL/IT/MDF	WALL MOUNTED	635	24000	26000	8	2/M500	60	1,2,3

- NOTES:
- PROVIDE WITH MANUFACTURER'S CONDENSATE PUMP ACCESSORY KIT. POWER WIRED FROM INDOOR UNIT.
  - INSTALL MANUFACTURER'S REFRIGERANT LINESET IN STRICT ACCORDANCE WITH MANUFACTURER'S INSTRUCTIONS. PROVIDE ADDITIONAL REFRIGERANT PIPING WHERE REQUIRED.
  - INDOOR UNIT POWERED FROM OUTDOOR UNIT. CONTRACTOR SHALL PROVIDE POWER AND CONTROL WIRING BETWEEN INDOOR AND OUTDOOR UNIT.

### SPLIT SYSTEM OUTDOOR UNIT SCHEDULE

EQUIPMENT TAG		MANUFACTURER	MODEL	LOCATION	COOLING CAPACITY [BTUH]	HEATING CAPACITY [BTUH]	REFRIGERANT LINE SIZE		ELECTRICAL				SEER	OPERATING WEIGHT [LB]	MOUNTING DETAIL	NOTES	
TYPE	UNIT #						RL [IN]	RS [IN]	PHASE	VOLT	MCA	MOP					FAN MOTOR AMPS
SCU	1	MITSUBISHI	PUZ-A24NH47	EXTERIOR WALL	24000	26000	3/8	5/8	1	208	19	26	0.4	21.4	200	3/M500	1

- NOTES:
- INSTALL MANUFACTURER'S REFRIGERANT LINESET IN STRICT ACCORDANCE WITH MANUFACTURER'S INSTRUCTIONS. PROVIDE ADDITIONAL REFRIGERANT PIPING WHERE REQUIRED.

### VAV BOX SCHEDULE

EQUIPMENT TAG		AREA SERVED	"TITUS" DESV SERIES	MIN CFM	MAX CFM	TOTAL AIR PRESSURE DROP	NC		CO2	NOTES
TYPE	UNIT #						DISCHARGE	RADIATED		
VAV	1	123 - LARGE MEETING ROOM	8	325	550	0.37	25	26	Yes	1,2

- NOTES:
- PROVIDE WITH COMBINATION THERMOSTAT/CO2 SENSOR. SEE FLOOR PLAN FOR LOCATION.
  - SCHEDULE MIN CFM IS THE AIR FLOW RATE THAT THE VAV BOX CAN TURN DOWN TO WHEN THE SPACE CO2 LEVEL IS LESS THAN THE DESIGN MINIMUM CO2 SET POINT OF 800 PPM.

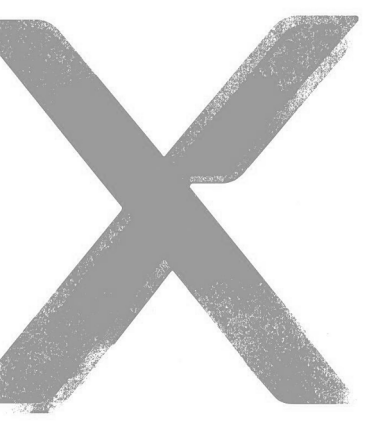

ARCH | NEXUS

Architectural NEXUS, Inc.  
 930 R Street  
 Sacramento, California 95811  
 T 916.443.5911  
 http://www.archnexus.com

Original drawings remain the property of the Architect and as such the Architect retains total ownership and control. The design represented by these drawings is sold to the client for a one time use, unless otherwise agreed upon in writing by the Architect. © Architectural Nexus, Inc. 2014



JD - JHM/WHC 189514.00  
 PW - DESIGN TEAM PROJECT NO.

EL DORADO COUNTY  
**EDC HHS TENANT IMPROVEMENT**  
 3368 SANDY WAY  
 SOUTH LAKE TAHOE, CA 96150



DATE SIGNED: 1-02-19  
 # Date Revision

### CONSTRUCTION DOCUMENTS

NEXUS PROJ. #: 18117  
 CHECKED BY: Checker  
 DRAWN BY: Author  
 DATE: 01.02.2019

### HVAC SCHEDULES

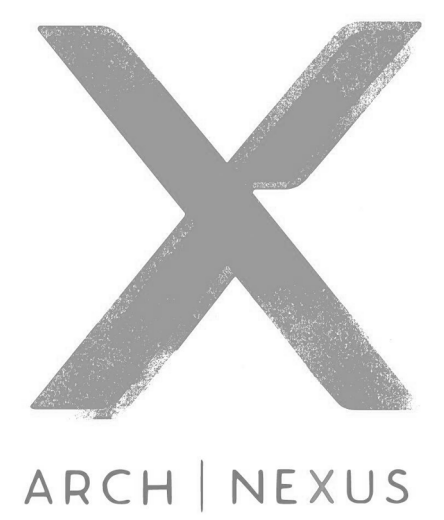

ARCHITECTURAL NEXUS, Inc.
930 R Street
Sacramento, California 95811
T 916.443.5911
http://www.archnexus.com

Original drawings remain the property of the Architect and as such the Architect retains total ownership and control. The design represented by these drawings is sold to the client for a one time use, unless otherwise agreed upon in writing by the Architect. © Architectural Nexus, Inc. 2014



EL DORADO COUNTY
EDC HHS TENANT IMPROVEMENT
3368 SANDY WAY
SOUTH LAKE TAHOE, CA 96150



DATE SIGNED: 1-02-19
# Date Revision

CONSTRUCTION DOCUMENTS

NEXUS PROJ. #: 18117
CHECKED BY: Checker
DRAWN BY: Author
DATE: 01.02.2019

TITLE 24 COMPLIANCE

M002
18-1912 Revised B 95 of 606
BOS Revd 1-24-19

STATE OF CALIFORNIA
REQUIRED ACCEPTANCE TESTS
CERTIFICATE OF COMPLIANCE
NRCC-MCH-04-E
Project Name: EDC HHS Tenant Improvement
Date Prepared: 11/14/2018

DOCUMENTATION AUTHOR'S DECLARATION STATEMENT
1. I certify that this Certificate of Compliance documentation is accurate and complete.
Documentation Author Name: Jessica Hughey
Signature Date: 11/14/2018

RESPONSIBLE PERSON'S DECLARATION STATEMENT
I certify the following under penalty of perjury, under the laws of the State of California:
1. The information provided on this Certificate of Compliance is true and correct.
2. I am eligible under Division 3 of the Business and Professions Code to accept responsibility for the building design or system design identified on this Certificate of Compliance (responsible designer).

CA Building Energy Efficiency Standards - 2016 Nonresidential Compliance January 2016

STATE OF CALIFORNIA
REQUIRED ACCEPTANCE TESTS
CERTIFICATE OF COMPLIANCE
NRCC-MCH-04-E
Project Name: EDC HHS Tenant Improvement
Date Prepared: 11/14/2018

Designer:
This compliance document is to be used by the designer and attached to the plans. Listed below are all the acceptance tests for mechanical systems. The designer is required to check the applicable boxes by all acceptance tests that apply and list all equipment that require an acceptance test.

Enforcement Agency:
Systems Acceptance. Before occupancy permit is granted for a newly constructed building or space, or a new space-conditioning system serving a building or space is operated for normal use, all control devices serving the building or space shall be certified as meeting the Acceptance Requirements for Code Compliance.

Systems Acceptance. Before occupancy permit is granted. All newly installed HVAC equipment must be tested using the Acceptance Requirements. The NRCC-MCH-04-E compliance document is not considered a completed document and is not to be accepted by the building department unless the correct boxes are checked.

Table with columns: Test Description, MCH-02-A, MCH-03-A, MCH-04-A, MCH-05-A, MCH-06-A, MCH-07-A, MCH-11-A, MCH-12-A, MCH-14-A, MCH-18-A, Test Performed By. Rows include AC-1, AC-2, AC-3, SHP-1.

CA Building Energy Efficiency Standards - 2016 Nonresidential Compliance January 2016

STATE OF CALIFORNIA
REQUIRED ACCEPTANCE TESTS
CERTIFICATE OF COMPLIANCE
NRCC-MCH-04-E
Project Name: EDC HHS Tenant Improvement
Date Prepared: 11/14/2018

A. MECHANICAL COMPLIANCE FORMS & WORKSHEETS
(indicate if worksheet is included)

For detailed instructions on the use of this and all Energy Standards compliance documents, refer to the 2016 Nonresidential Manual. Note: The Enforcement Agency may require all compliance documents to be incorporated onto the building plans.

Table with columns: YES, NO, Form, Title. Rows include NRCC-MCH-04-E (1 of 2), NRCC-MCH-04-E (2 of 2), NRCC-MCH-05-E (1 of 2), NRCC-MCH-05-E (2 of 2).

CA Building Energy Efficiency Standards - 2016 Nonresidential Compliance January 2016

STATE OF CALIFORNIA
REQUIRED ACCEPTANCE TESTS
CERTIFICATE OF COMPLIANCE
NRCC-MCH-05-E
Project Name: EDC HHS Tenant Improvement
Date Prepared: 11/14/2018

DOCUMENTATION AUTHOR'S DECLARATION STATEMENT
1. I certify that this Certificate of Compliance documentation is accurate and complete.
Documentation Author Name: Jessica Hughey
Signature Date: 11/14/2018

RESPONSIBLE PERSON'S DECLARATION STATEMENT
I certify the following under penalty of perjury, under the laws of the State of California:
1. The information provided on this Certificate of Compliance is true and correct.
2. I am eligible under Division 3 of the Business and Professions Code to accept responsibility for the building design or system design identified on this Certificate of Compliance (responsible designer).

CA Building Energy Efficiency Standards - 2016 Nonresidential Compliance January 2016

STATE OF CALIFORNIA
REQUIRED ACCEPTANCE TESTS
CERTIFICATE OF COMPLIANCE
NRCC-MCH-05-E
Project Name: EDC HHS Tenant Improvement
Date Prepared: 11/14/2018

Table with columns: Equipment Tag(s), MANDATORY MEASURES, PRESCRIPTIVE MEASURES. Rows include Heating Equipment Efficiency, Cooling Equipment Efficiency, Thermostats, Furnace Standby Loss Control, etc.

Notes:
1. Provide equipment tags (e.g. AC1 or AC1 to 10). Multiple units of the same make and model with the same application and accessories can be grouped together.
2. Enter the following information as appropriate: Unit Manufacturer; Unit Model Number (including all accessories); Description of the unit (e.g. gas-pack or heat pump; rated heating capacity (enter "N/A" if no heating); and, rated cooling capacity (enter "N/A" if no cooling). For unit capacities include the units (e.g. kBtu/h or tons).

CA Building Energy Efficiency Standards - 2016 Nonresidential Compliance January 2016

STATE OF CALIFORNIA
REQUIREMENTS FOR PACKAGED SINGLE ZONE UNITS
CERTIFICATE OF COMPLIANCE
NRCC-MCH-05-E
Project Name: EDC HHS Tenant Improvement
Date Prepared: 11/14/2018

Table with columns: Equipment Tag(s), MANDATORY MEASURES, PRESCRIPTIVE MEASURES. Rows include Heating Equipment Efficiency, Cooling Equipment Efficiency, Thermostats, Furnace Standby Loss Control, etc.

Notes:
1. Provide equipment tags (e.g. AC1 or AC1 to 10). Multiple units of the same make and model with the same application and accessories can be grouped together.
2. Enter the following information as appropriate: Unit Manufacturer; Unit Model Number (including all accessories); Description of the unit (e.g. gas-pack or heat pump; rated heating capacity (enter "N/A" if no heating); and, rated cooling capacity (enter "N/A" if no cooling). For unit capacities include the units (e.g. kBtu/h or tons).

CA Building Energy Efficiency Standards - 2016 Nonresidential Compliance January 2016

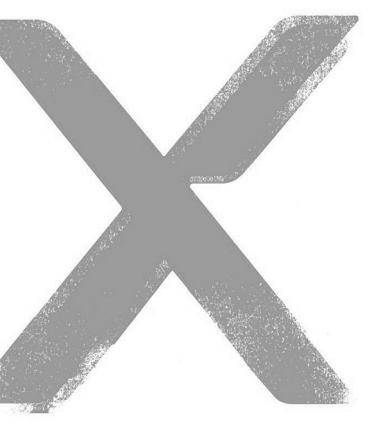

ARCH | NEXUS

Architectural NEXUS, Inc.  
930 R Street  
Sacramento, California 95811  
T 916.443.5911  
http://www.archnexus.com

Original drawings remain the property of the Architect and as such the Architect retains total ownership and control. The design represented by these drawings is sold to the client for a one time use, unless otherwise agreed upon in writing by the Architect. © Architectural Nexus, Inc. 2014



EL DORADO COUNTY  
**EDC HHS TENANT IMPROVEMENT**  
3368 SANDY WAY  
SOUTH LAKE TAHOE, CA 96150



DATE SIGNED: 1-02-19  
# Date Revision

**CONSTRUCTION DOCUMENTS**

NEXUS PROJ. #: 18117  
CHECKED BY: Checker  
DRAWN BY: Author  
DATE: 01.02.2019

**HVAC DEMO PLAN**

**M100**  
18-1912 Revised B 99 of 606  
BOS Rcvd 1-24-19

**KEYNOTES:**

① DEMOLISH (E) ROOFTOP AC UNIT. DUCT DROPS THRU ROOF AND ROOF CURB TO REMAIN. PREPARE FOR RECONNECTION TO NEW AC UNIT AND CURB ADAPTER.



**1** HVAC DEMO PLAN  
M100 SCALE: 1/4" = 1'-0"  
N



12/20/19 11:45:27 AM

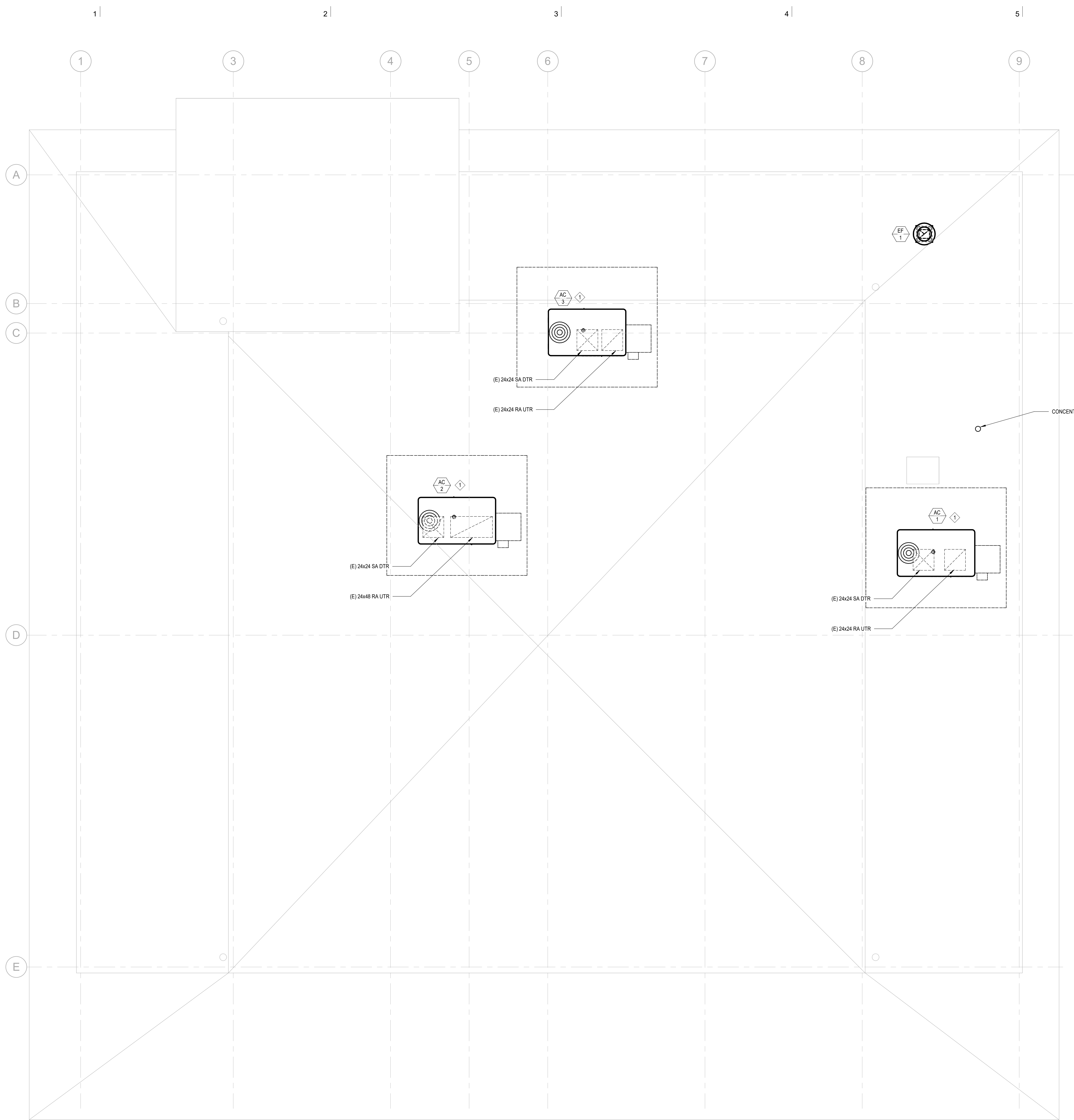

**KEYNOTES:**  
 1 PROVIDE UNITS WITH ROOF CURB ADAPTERS, TRANSITION (E) DUCTS TO AC UNIT CONNECTIONS AS REQUIRED.



**ARCH | NEXUS**  
 Architectural NEXUS, Inc.  
 930 R Street  
 Sacramento, California 95811  
 T 916.443.5911  
 http://www.archnexus.com

Original drawings remain the property of the Architect and as such the Architect retains total ownership and control. The design represented by these drawings is sold to the client for a one time use, unless otherwise agreed upon in writing by the Architect.  
 © Architectural Nexus, Inc. 2014

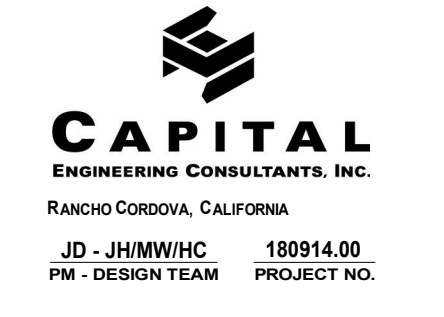

**EL DORADO COUNTY  
 EDC HHS TENANT IMPROVEMENT**  
 3368 SANDY WAY  
 SOUTH LAKE TAHOE, CA 96150



DATE SIGNED: 1-02-19  
 # Date Revision

**CONSTRUCTION DOCUMENTS**

NEXUS PROJ. #: 18117  
 CHECKED BY: Checker  
 DRAWN BY: Author  
 DATE: 01.02.2019

**HVAC ROOF PLAN**

**1 HVAC ROOF PLAN**  
 M201 SCALE: 1/4" = 1'-0"

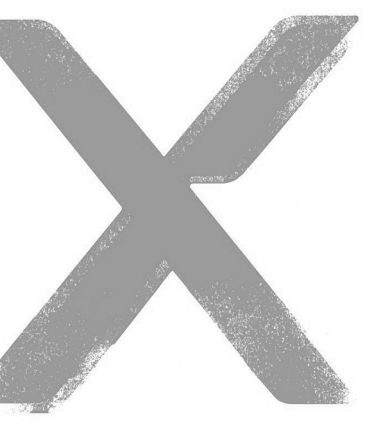

ARCH | NEXUS

Architectural NEXUS, Inc.  
930 R Street  
Sacramento, California 95811  
T 916.443.5911  
http://www.archnexus.com

Original drawings remain the property of the Architect and as such the Architect retains total ownership and control. The design represented by these drawings is sold to the client for a one time use, unless otherwise agreed upon in writing by the Architect. © Architectural Nexus, Inc. 2014

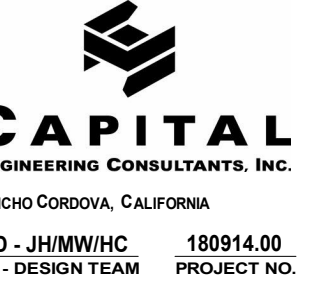

**EL DORADO COUNTY  
EDC HHS TENANT IMPROVEMENT**  
3368 SANDY WAY  
SOUTH LAKE TAHOE, CA 96150

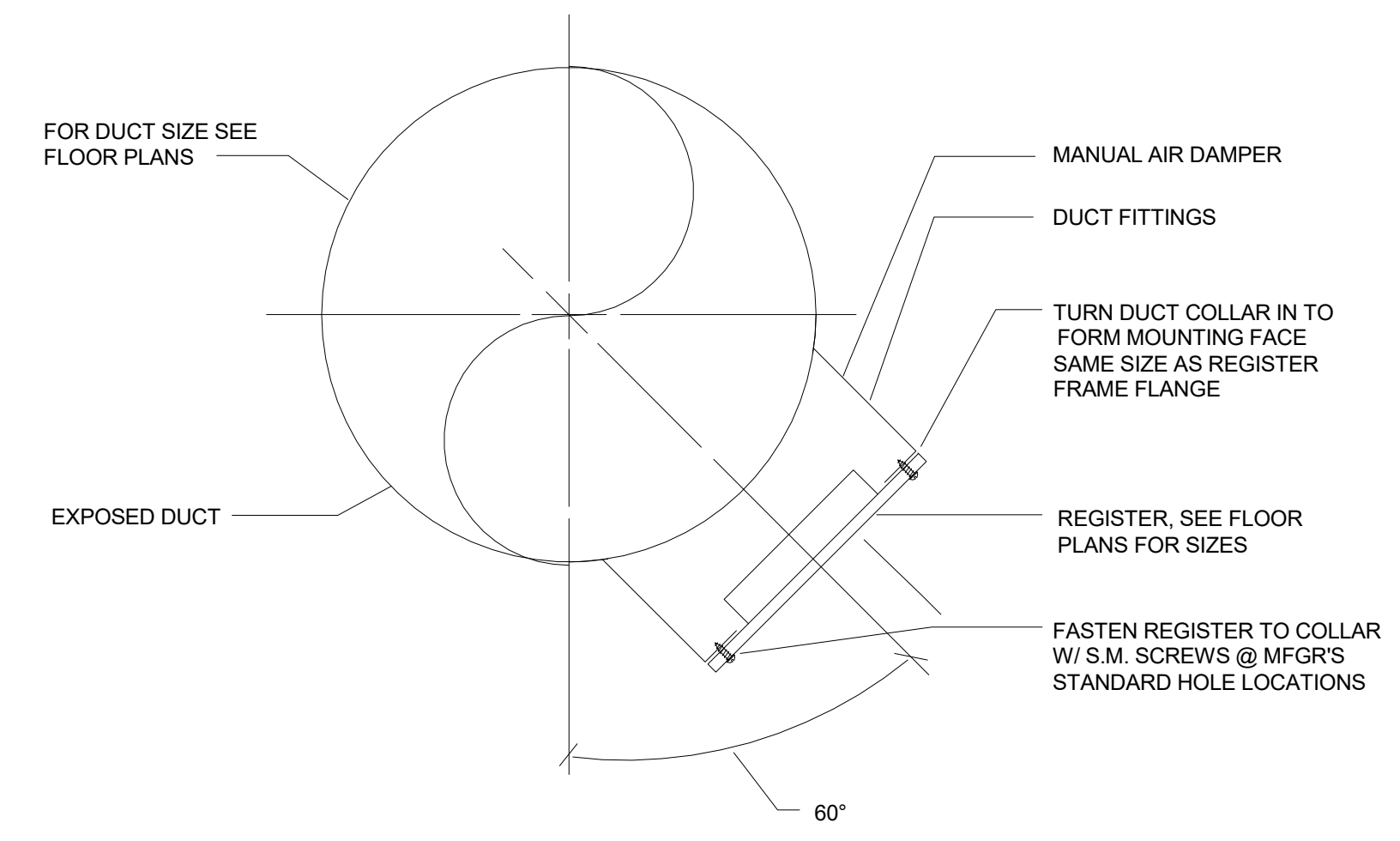

**DIFFUSER/GRILLE ON EXPOSED DUCT**  
SCALE: NONE

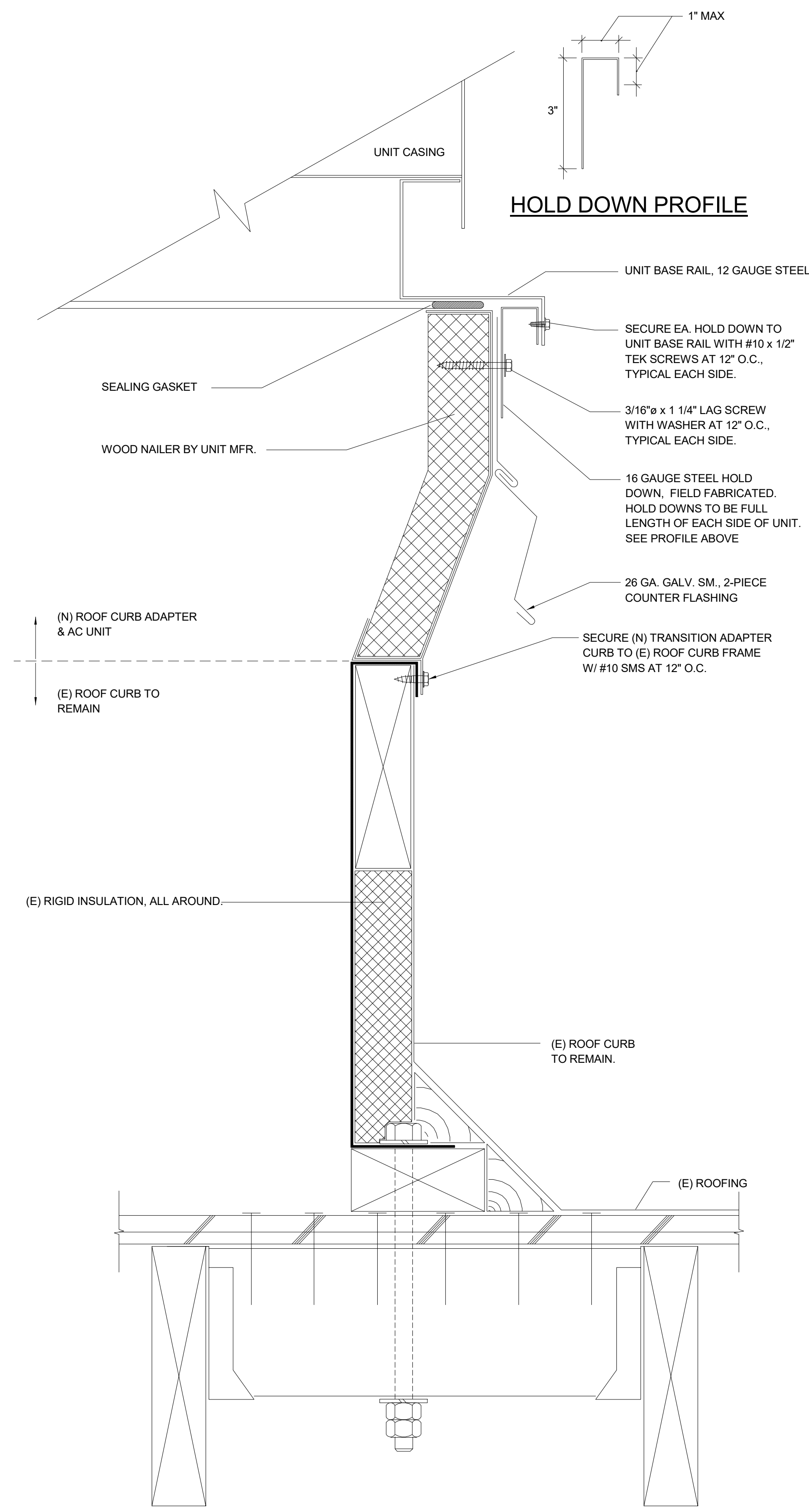

**AC UNIT MOUNTING**  
SCALE: NONE

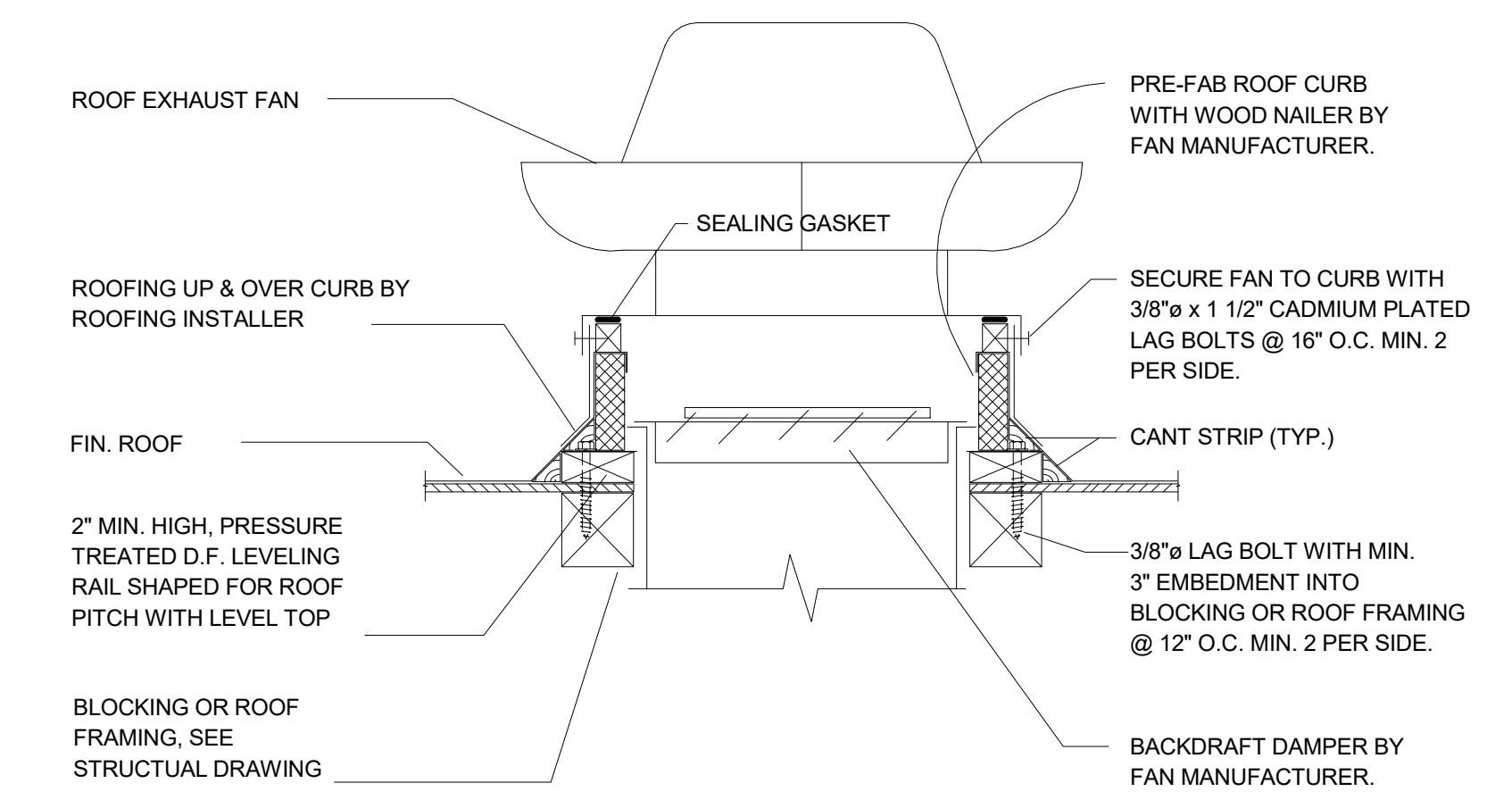

**ROOF EXHAUST FAN MOUNTING**  
SCALE: NONE

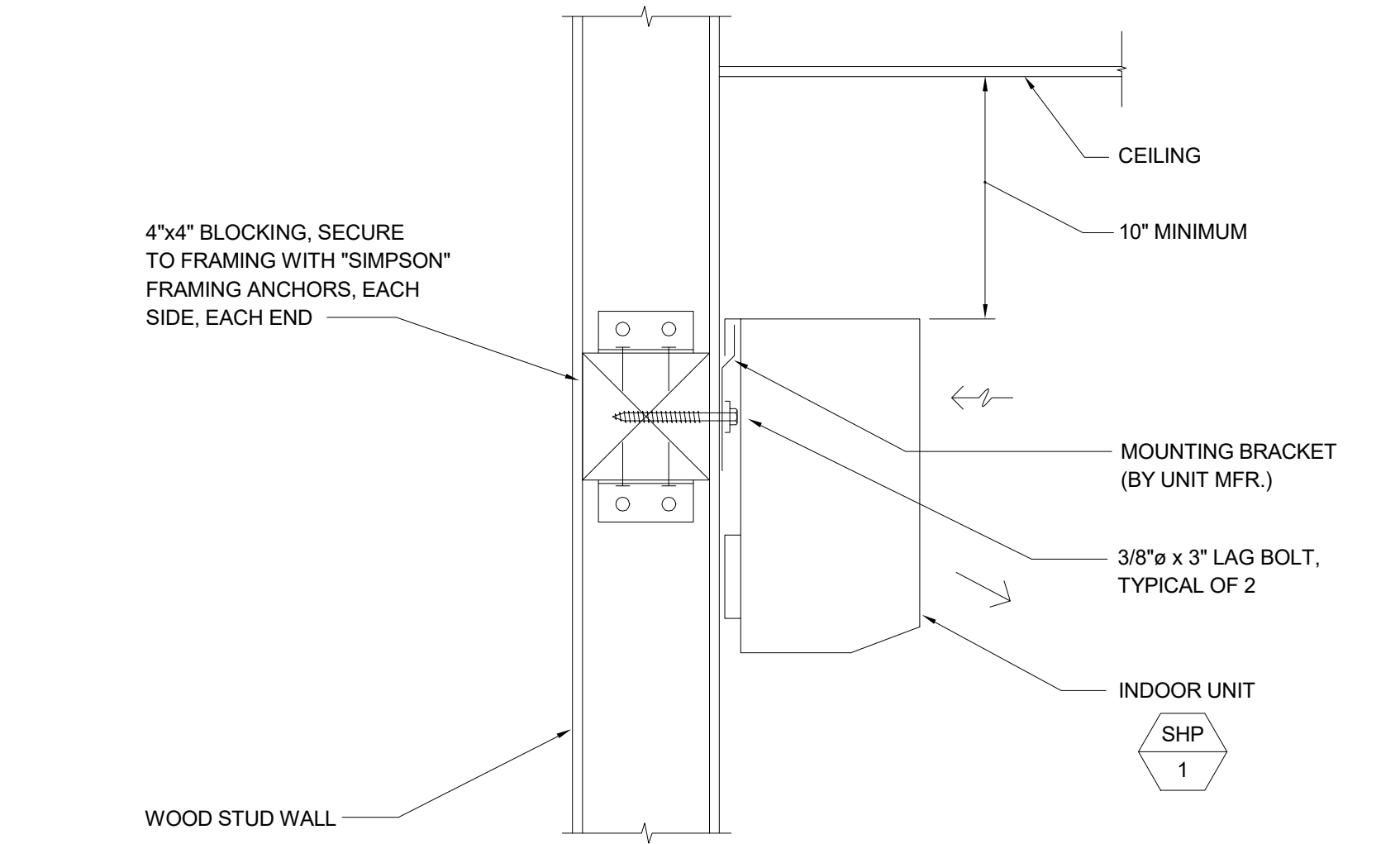

**SPLIT SYSTEM INDOOR MOUNTING**  
SCALE: NONE

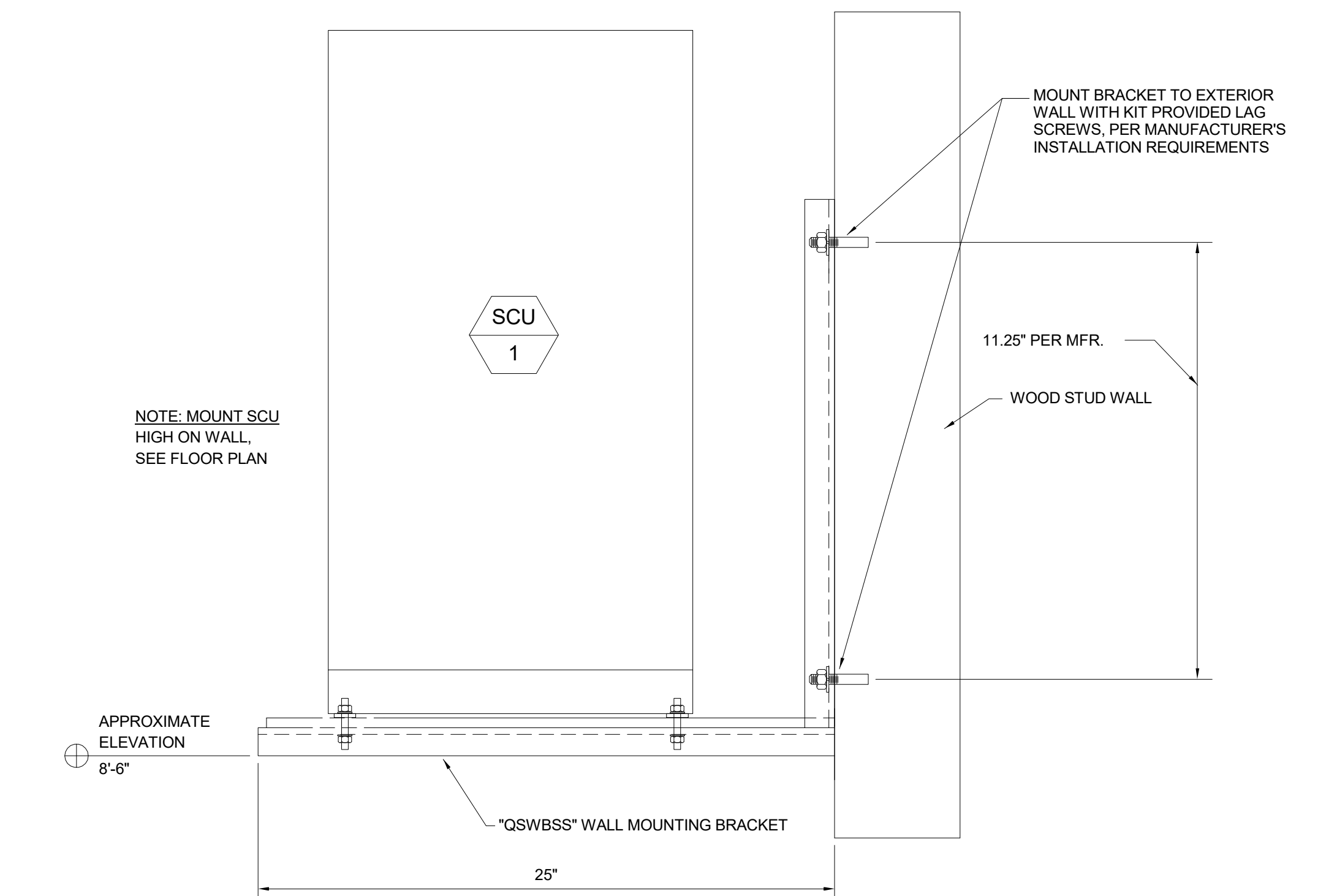

**SCU MOUNTING AT EXTERIOR WALL**  
SCALE: NONE

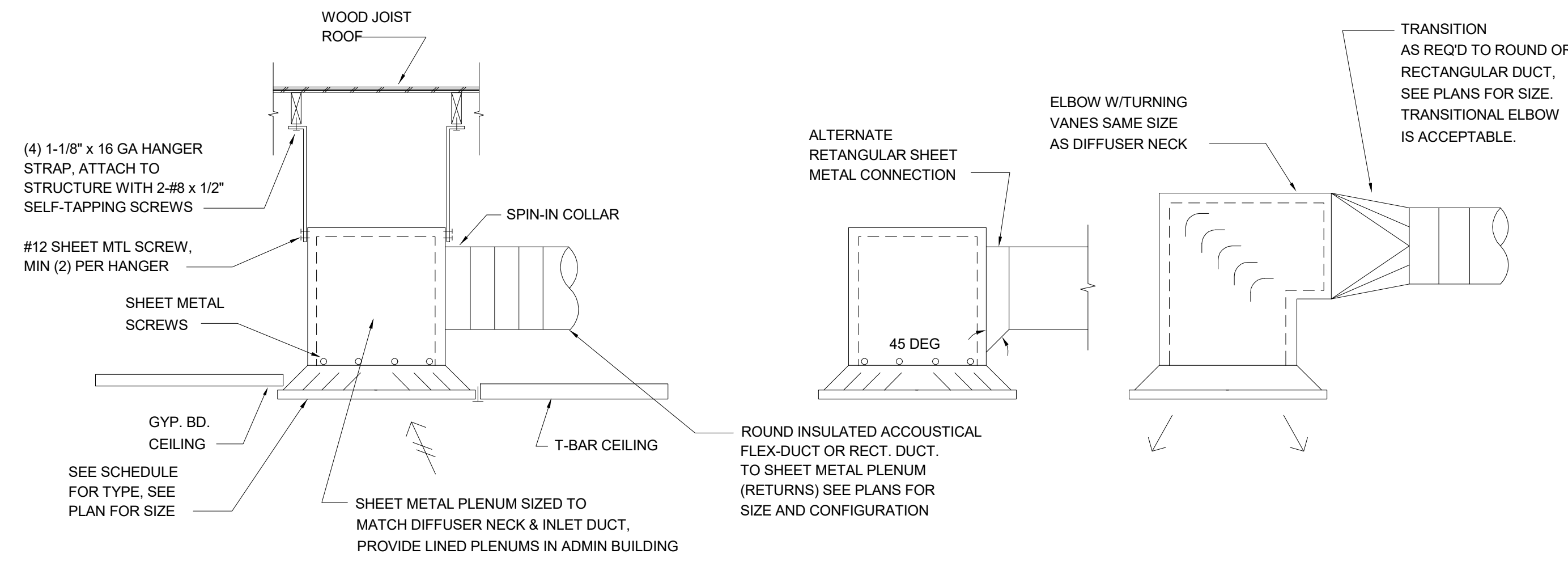

**SUPPLY, RETURN, & EXHAUST TERMINAL**  
SCALE: NONE



DATE SIGNED: 1-02-19  
# Date Revision

**CONSTRUCTION DOCUMENTS**

NEXUS PROJ. #: 18117  
CHECKED BY: Checker  
DRAWN BY: Author  
DATE: 01.02.2019

**HVAC DETAILS**

**M500**  
18-1912 Revised B 102 of 606  
BOS Revd 1-24-19

PLUMBING SYMBOLS			PLUMBING SYMBOLS		
SYMBOL	ABBREVIATION	DESCRIPTION	SYMBOL	ABBREVIATION	DESCRIPTION
	140 HW	140° HOT WATER			PENDANT SPRINKLER HEAD
	180 HW	180° HOT WATER		PD	PUMP DISCHARGE
	A	COMPRESSED AIR		PG	PRESSURE GAUGE
	AD	AREA DRAIN			PIPE DROP UNLESS OTHERWISE NOTED
		AQUASTAT			PIPE UP UNLESS OTHERWISE NOTED
		AUTOMATIC AIR VENT			PIPE IN PIPE CONDUIT/SLEEVE
		BEAM PENETRATION			PIPE ANCHOR
	BFP	BACKFLOW PREVENTER (BFP)			PLUGGED TEE
	BV	BALANCING VALVE			PLUG VALVE
	BAV	BALL VALVE		POC	POINT OF CONNECTION
		BRANCH CONNECTION		PRV	PRESSURE RELIEF VALVE
	BFV	BUTTERFLY VALVE			PRESSURE REDUCING VALVE ASSEMBLY
					PRESSURE REDUCING VALVE
				PSW	PRESSURE SWITCH
				RD	ROOF DRAIN
		RAIN WATER LEADER ABOVE GRADE OR FLOOR		RWL	RAIN WATER LEADER BELOW GRADE OR FLOOR
	CB	CATCH BASIN			REMOTE FLUSH PUSH BUTTON
	CD	CONDENSATE PIPING			
	CHO	CHASSIS OIL			
		CHECK VALVE			GAS SHUT-OFF VALVE
		CIRCULATING PUMP		SS	SOIL OR WASTE ABOVE GRADE OR FLOOR
	CW	COLD WATER		S OR W	SOIL OR WASTE BELOW GRADE OR FLOOR
	CWV	COMBINED WASTE AND VENT		SAWHA	SHOCK ABSORBER/WATER HAMMER ARRESTOR
	CO, WCO	CLEAN OUT, WALL CLEANOUT			SIDE WALL SPRINKLER HEAD
	LOW HIGH	DROP OR RISE			SOLENOID VALVE
		EXISTING TO BE REMOVED		SOV	SHUT OFF VALVE
	EL	EXPANSION LOOP		SP	STANDPIPE
		SCHEDULE REFERENCE NUMBER		SP	FIRE SPRINKLER
	F	FIRE SERVICE		SPD	FIRE SPRINKLER DRAIN
	FC	FLEXIBLE CONNECTOR		STR	STRAINER
	FCO	FLOOR CLEANOUT		SW	SOFTENED WATER
	FD	FLOOR DRAIN		T	THERMOMETER
	FDC	FIRE DEPARTMENT CONNECTION		TMV	THERMOSTATIC MIXING VALVE
	FH	FIRE HYDRANT		TP	TRAP PRIMER PIPING
	FHC	FIRE HOSE CABINET		TP	TRAP PRIMER
	FHR	FIRE HOSE RACK			TRAP
	FHV	FIRE HOSE VALVE		TPRV	TEMPERATURE AND PRESSURE RELIEF VALVE
	FS	FLOOR SINK			T & PRV PIPING
		FIRE SPRINKLER FLOOR CONTROL ASSY.		TW	TEMPERED WATER
	FSW	FLOW SWITCH		TWR	TEMPERED WATER RETURN
				U	UNION
	MPG	MEDIUM PRESSURE GAS			UPRIGHT SPRINKLER HEAD
	G	LOW PRESSURE GAS			
	GO	GRADE CLEANOUT		V	VENT
	GLV	GLOBE VALVE		V(R)	VENT (RISER)
	GPR	GAS PRESSURE REGULATOR			VENT INCREASER
	GVVB	GATE VALVE IN VALVE BOX		VB	VALVE BOX
	GW	GREASE WASTE PIPING		VB	VACUUM BREAKER
				VW	VACUUM WASTE
	HB	HOSE BIBB		VTR	VENT THRU ROOF
	HW	HOT WATER			
	HWR	HOT WATER RETURN		W	WASTE
	IW	INDIRECT WASTE		WH	WALL HOSE
				WHA	WATER HAMMER ARRESTOR
	MPG	MEDIUM PRESSURE GAS		WH	WALL HYDRANT
	OD	OVERFLOW DRAIN			EQUIPMENT DESIGNATION SCHEDULE REFERENCE NUMBER
	OFL	OVERFLOW LEADER ABOVE GRADE			FIXTURE DESIGNATION SCHEDULE REFERENCE NUMBER
	OFL	OVERFLOW LEADER BELOW GRADE			DETAIL NUMBER DRAWING REFERENCE NUMBER

PLUMBING ABBREVIATIONS		PLUMBING ABBREVIATIONS	
ABBREVIATION	DESCRIPTION	ABBREVIATION	DESCRIPTION
ABC	ABOVE CEILING	NO	NORMALLY OPEN
ACC DR	ACCESS DOOR	NTS	NOT TO SCALE
ACC P	ACCESS PANEL	OFCI	OWNER FURNISHED, CONTRACTOR INSTALLED
AFF	ABOVE FINISHED FLOOR	OFO	OWNER FURNISHED, OWNER INSTALLED
AFG	ABOVE FINISHED GRADE	OH	OVERHEAD
AFP	ABOVE FINISHED PAVEMENT	OS & Y	OUTSIDE SCREW AND YOKE
AHV	AIR HOSE VALVE	PH	PHASE
AIP	ABANDON IN PLACE	PLBG	PLUMBING
ASH	AUTOMATIC SPRINKLER HEAD	PLD	PLANTER DRAIN
BEL	BELOW	PO	PLUGGED OUTLET
BFF	BELOW FINISHED FLOOR	PRS	PRE-RINSE SINK
BFG	BELOW FINISHED GRADE	PS	POT SINK
BFP	BACKFLOW PREVENTER	PT	PLASTER TRAP
BLDG	BUILDING	(R)	RISER
CDC	CALIFORNIA DEPARTMENT OF CORRECTIONS	REC	RECESSED
CFE	CAPPED FOR FUTURE	REQD	REQUIRED
CLG	CEILING	REV	REVISION
CMP	CORRUGATED METAL PIPE	RM	ROOM
COL	COLUMN	RPBP	REDUCED PRESSURE BACKFLOW PREVENTER
CONN	CONNECT/CONNECTION	RWL	RAIN WATER LEADER
CONT	CONTINUATION	SD	STORM DRAIN
CWH	COLD WATER HEADER	SH	SHOWER
(D)	DROP	SPEC	SPECIFICATION
DF	DRINKING FOUNTAIN	SS	STAINLESS STEEL SERVICE SINK
DIA	DIAMETER	STD	STANDARD
DN	DOWN	STRUC	STRUCTURAL
DW	DRY WELL	(TA)	TO ABOVE
DW	DISHWASHER	(TB)	TO BELOW
DWG	DRAWING	T.C.C.	TEMPERATURE CONTROLS CONTRACTOR
(E)	EXISTING	TD	TRENCH DRAIN
EL	ELEVATION	TEMP	TEMPERATURE
ELEC	ELECTRICAL	TOC	TOP OF CONCRETE
EQUIP	EQUIPMENT	TS	TAMPER SWITCH
ES	EMERGENCY SHOWER	THW	TEMPERED HOT WATER
EW	EYE WASH	TYP	TYPICAL
EWC	ELECTRIC WATER COOLER	UF	UNDER FLOOR
FA	FROM ABOVE	UG	UNDERGROUND
FB	FROM BELOW	UL	UNDERWRITERS' LABORATORIES
FD	FLOOR DRAIN	UR	URNAL
FFE	FINISHED FLOOR ELEVATION	US	UNDER SLAB
FF	FINISHED FLOOR	V	VENT
FLR	FLOOR	VTR	VENT THRU ROOF
FSR	FIRE SPRINKLER RISER	VO	VALVED OUTLET
FT	FLOOR TOILET	VW	VACUUM WASTE
/FT	PER FOOT	W	WITH
FTK	FLUSH TANK	W/O	WITHOUT
FU	FIXTURE UNIT	W	WASTE
FV	FLUSH VALVE	WC	WATER CLOSET
GAL	GALLONS	WCL	WATER CLOSET AND LAVATORY
		WF	WASH FOUNTAIN
		ZCV	ZONE CONTROL VALVE
HC	HANDICAPPED		
HR	HOSE		
HS	HAND SINK		
HT	HEIGHT		
HTR	HEATER		
HWH	HOT WATER HEATER		
I	INVERT ELEVATION		
KEC	KITCHEN EQUIPMENT CONTRACTOR		
KS	KITCHEN SINK		
LV	LAVATORY		
MC	MOTOR CONTROLLER		
MECH	MECHANICAL		
MTD	MOUNTED		
(N)	NEW		
NC	NORMALLY CLOSED		

GENERAL NOTES	
1.	CLOSELY COORDINATE WORK WITH OTHER TRADES PRIOR TO TRENCHING OR INSTALLING PIPING AND ASSOCIATED ITEMS.
2.	DRAWINGS SHALL BE CONSIDERED DIAGRAMMATIC ONLY. CONTRACTOR SHALL FIELD VERIFY EXACT LOCATIONS, SIZES AND ELEVATIONS OF ALL ITEMS PRIOR TO THE INSTALLATION OF ALL NEW WORK. APPROVED SHOP DRAWINGS ARE REQUIRED PRIOR TO INSTALLATION OF ALL NEW WORK.
3.	KEEP VTR'S A MINIMUM OF 10 FEET FROM FRESH AIR INTAKES AND 4 FEET MINIMUM FROM EXTERIOR WALLS WHETHER SHOWN ON PLANS OR NOT.
4.	ALL BALL VALVES SHALL BE LINE SIZE.
5.	SLOPE ALL GRAVITY WASTE PIPING AT 1/4" PER FOOT UNLESS OTHERWISE NOTED.
6.	PROVIDE WATER HAMMER ARRESTORS (WHA) AS INDICATED IN SPECIFICATIONS, AT EVERY FIXTURE AND BANK OF FIXTURES, AND PRIOR TO ANY SOLENOID VALVE OR OTHER QUICK CLOSING VALVE. SIZE PER PDI.
7.	18"x18" (UON) ACCESS DOORS (AD) SHALL BE PROVIDED AS REQUIRED. CONTRACTOR SHALL ESTABLISH QUANTITY AND LOCATION OF ALL ACCESS PANELS NECESSARY FOR ACCESS TO ALL EQUIPMENT REQUIRING OPERATION OR SERVICING INCLUDING VALVES, WATER HAMMER ARRESTORS AND TRAP PRIMERS. REFER TO ARCHITECTURAL REFLECTED CEILING PLANS FOR COORDINATION.
8.	HVAC EQUIPMENT IS SHOWN FOR THE COORDINATION OF UTILITIES ONLY. SEE "M" SHEETS FOR MORE INFORMATION.
9.	CONNECT CONDENSATE DRAIN PIPING TO AC UNITS WITH P-TRAP. PROVIDE CLEAN OUTS AT ALL CHANGES IN DIRECTION. MIN DEPTH OF P-TRAP IS TO BE AS REQUIRED BY AC UNIT MANUFACTURER.
10.	PROVIDE TRAP PRIMERS FOR ALL FLOOR DRAINS, FLOOR SINKS, HOPPER DRAINS, AND SHOWER DRAINS. FOR DETAIL SEE 2/P500
11.	INSULATE HOT WATER FAUCET SUPPLIES UP TO THE FAUCETS IN ADDITION TO PIPE INSULATION SPECIFIED IN DIVISION 22.
12.	PROVIDE AND INSTALL CHECK VALVES ON CW & HW SUPPLIES TO ALL SINK FAUCETS WITH TEMPERING VALVES.
13.	MINIMUM DOMESTIC CW & HW SIZE SHALL BE 3/4".

PLUMBING EQUIPMENT SCHEDULE	
TAG	DESCRIPTION
	<b>EXPANSION TANK</b> "ARM-TROL" THERM-X-TROL, MODEL ST-12, STEEL TANK, HEAVY DUTY NSF/ANSI 61, POLYPROPYLENE LINER, 50 PSIG FACTORY PRECHARGE, 150 PSIG WORKING PRESSURE, (4.4 GALLON TANK VOLUME, 3.2 GALLON ACCEPTANCE VOLUME) (9 LBS. OPERATING WEIGHT)
	<b>DOMESTIC WATER CIRCULATION PUMP</b> "TACO" 0013 LEAD-FREE CIRCULATOR PUMP, INTEGRAL TO TMV-1 MIXING VALVE STATION (SEE ENTRY BELOW), 1/6 HP MOTOR, .5GPM @ 8.5 FT+20" HEAD, 120V/1ø POWER BY DIV. 26.

MEP COMPONENT ANCHORAGE NOTE	
ALL MECHANICAL, PLUMBING, AND ELECTRICAL COMPONENTS SHALL BE ANCHORED AND INSTALLED PER THE DETAILS ON THE DSA APPROVED CONSTRUCTION DOCUMENTS. WHERE NO DETAIL IS INDICATED, THE FOLLOWING COMPONENTS SHALL BE ANCHORED OR BRACED TO MEET THE FORCE AND DISPLACEMENT REQUIREMENTS PRESCRIBED IN THE 2013 CBC, SECTIONS 1616A.1.18 THROUGH 1616A.1.26 AND ASCE 7-10 CHAPTERS 13, 29 AND 30.	
<ol style="list-style-type: none"> <li>ALL PERMANENT EQUIPMENT AND COMPONENTS.</li> <li>TEMPORARY OR MOVABLE EQUIPMENT THAT IS PERMANENTLY ATTACHED (e.g. HARD WIRED) TO THE BUILDING UTILITY SERVICES SUCH AS ELECTRICITY, GAS OR WATER.</li> <li>MOVABLE EQUIPMENT WHICH IS STATIONED IN ONE PLACE FOR MORE THAN 6 HOURS AND HEAVIER THAN 400 POUNDS ARE REQUIRED TO BE ANCHORED WITH TEMPORARY ATTACHMENTS.</li> </ol>	
THE ATTACHMENT OF THE FOLLOWING MECHANICAL AND ELECTRICAL COMPONENTS SHALL BE POSITIVELY ATTACHED TO THE STRUCTURE, BUT NEED NOT BE DETAILED ON THE PLANS. THESE COMPONENTS SHALL HAVE FLEXIBLE CONNECTIONS PROVIDED BETWEEN THE COMPONENT AND ASSOCIATED DUCTWORK, PIPING, AND CONDUIT.	
<ol style="list-style-type: none"> <li>COMPONENTS WEIGHING LESS THAN 400 POUNDS AND HAVE A CENTER OF MASS LOCATED 4 FEET OR LESS ABOVE THE ADJACENT FLOOR OR ROOF LEVEL THAT DIRECTLY SUPPORT THE COMPONENT.</li> <li>COMPONENTS WEIGHING LESS THAN 20 POUNDS, OR IN THE CASE OF DISTRIBUTION SYSTEMS, LESS THAN 5 POUNDS PER FOOT, WHICH ARE SUSPENDED FROM A ROOF OR FLOOR OR HUNG FROM A WALL.</li> </ol>	
FOR THOSE ELEMENTS THAT DO NOT REQUIRE DETAILS ON THE APPROVED DRAWINGS, THE INSTALLATION SHALL BE SUBJECT TO THE APPROVAL OF THE STRUCTURAL ENGINEER OF RECORD AND THE DSA DISTRICT STRUCTURAL ENGINEER. THE PROJECT INSPECTOR WILL VERIFY THAT ALL COMPONENTS AND EQUIPMENT HAVE BEEN ANCHORED IN ACCORDANCE WITH ABOVE REQUIREMENTS.	

PIPING, DUCTWORK & ELECTRICAL DISTRIBUTION SYSTEM BRACING NOTE	
PIPING, DUCTWORK, AND ELECTRICAL DISTRIBUTION SYSTEMS SHALL BE BRACED TO COMPLY WITH THE FORCES AND DISPLACEMENTS PRESCRIBED IN ASCE 7-10 SECTION 13.3 AS DEFINED IN ASCE 7-10 SECTION 13.6.8, 13.6.7, 13.6.5.6, AND 2013 CBC, SECTIONS 1616A.1.23, 1616A.1.24, 616A.1.25 AND 1616A.1.26.	
THE BRACING AND ATTACHMENTS TO THE STRUCTURE SHALL BE DETAILED ON THE APPROVED DRAWINGS OR THEY SHALL COMPLY WITH ONE OF THE CSHPD PRE-APPROVALS (OPM #)	
COPIES OF THE MANUAL SHALL BE AVAILABLE ON THE JOBSITE PRIOR TO THE START OF HANGING THE BRACING OF THE PIPE, DUCTWORK, AND ELECTRICAL DISTRIBUTION SYSTEMS.	
THE STRUCTURAL ENGINEER OF RECORD SHALL VERIFY THE ADEQUACY OF THE STRUCTURE TO SUPPORT THE HANGER AND BRACE LOADS.	

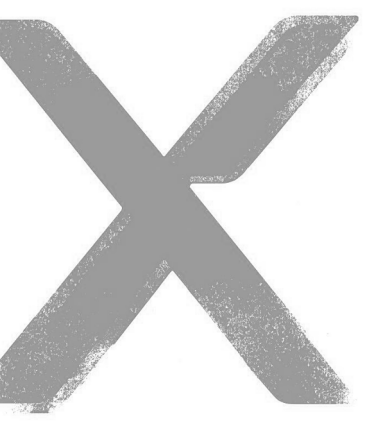

ARCH | NEXUS

Architectural NEXUS, Inc.  
930 R Street  
Sacramento, California 95811  
T 916.443.5911  
http://www.archnexus.com

Original drawings remain the property of the Architect and as such the Architect retains total ownership and control. The design represented by these drawings is sold to the client for a one time use, unless otherwise agreed upon in writing by the Architect.  
© Architectural Nexus, Inc. 2014



JD - JHM/WHC 189514.00  
PW - DESIGN TEAM PROJECT NO.

EL DORADO COUNTY  
EDC HHS TENANT IMPROVEMENT  
3368 SANDY WAY  
SOUTH LAKE TAHOE, CA 96150



DATE SIGNED: 1-02-19  
# Date Revision

CONSTRUCTION DOCUMENTS

NEXUS PROJ. #: 18117  
CHECKED BY: Checker  
DRAWN BY: Author  
DATE: 01.02.2019

PLUMBING LEGEND, NOTES, AND SCHEDULES

P000  
18-1912 Revised B 103 of 606  
BOS Revd 1-24-19

ADA	SYMBOL	FIXTURE	FIXTURE MANUFACTURER AND MODEL No.	FAUCET OR VALVE MANUFACTURER AND MODEL No.	TRIM AND SUPPORT MANUFACTURER AND MODEL No.	REMARKS	VENT	WASTE		COLD WATER		HOT WATER	
								BRANCH	OUTLET	BRANCH	OUTLET	BRANCH	OUTLET
	WC-1	WATER CLOSET FLOOR MOUNTED FLUSH VALVE	*KOHLER* HIGHCLIFF NO. K-96057-SS. FLOOR MOUNTED, ELONGATED, SIPHON JET ACTION 1-1/2" TOP SPUD, 16-7/8" RIM HEIGHT, 1.28 GPF, ANTIMICROBIAL.	PROVIDE "SLOAN" ROYAL MODEL 111-1.28 MANUAL FLUSH FLUSHOMETER VALVE ASSEMBLY, 1.28 GPF, CHROMED PLATED WITH ADJUSTABLE TAILPIECE.	SEAT: "BEMIS COMMERCIAL" MODEL 195SCT195SSSCT, OPEN FRONT LESS COVER, ELONGATED, HEAVY DUTY, INJECTION MOLDED, SOLID PLASTIC FRONT SEAT.		2"	4"	4"	1-1/4"	1"	-	-
	WC-2	WATER CLOSET FLOOR MOUNTED FLUSH VALVE ADA	*KOHLER* HIGHCLIFF NO. K-96057-SS. FLOOR MOUNTED, ELONGATED, SIPHON JET ACTION 1-1/2" TOP SPUD, 16-7/8" RIM HEIGHT, 1.28 GPF, ANTIMICROBIAL.	PROVIDE "SLOAN" ROYAL MODEL 111-1.28 MANUAL FLUSH FLUSHOMETER VALVE ASSEMBLY, 1.28 GPF, CHROMED PLATED WITH ADJUSTABLE TAILPIECE.	SEAT: "BEMIS COMMERCIAL" MODEL 195SCT195SSSCT, OPEN FRONT LESS COVER, ELONGATED, HEAVY DUTY, INJECTION MOLDED, SOLID PLASTIC FRONT SEAT.		2"	4"	4"	1-1/4"	1"	-	-
	UR-1	URINAL WALL MOUNTED FLUSH VALVE	*KOHLER* BARDON 1/8 GPF NO. K-4991-ET WALL HUNG, VITREOUS CHINA, SIPHON JET ACTION 3/4" TOP SPUD, 2" THREADED OUTLET, 0.125 GPF.	PROVIDE "SLOAN" ROYAL 186 HEU 0.125, 0.125 GPF (MANUAL)	CARRIER: "J.R. SMITH" 637 SERIES		1-1/2"	2"	2"	1"	3/4"	-	-
	L-1	LAVATORY COUNTER MOUNT HOT AND COLD WATER ADA	*KOHLER* PENNINGTON MODEL K-2198-4. ADA LAVATORY, COUNTER MOUNT, VITREOUS CHINA, OVAL BASIN, FRONT OVERFLOW, 4" CENTERS, 20 1/4" x 14 1/2"	*DELTA* MODEL 500-DST, 4" DECK MOUNT MIXING FAUCET, SINGLE HANDLE 1.2 GPM, COMPLIES WITH ASME A112.18.1 / CSA B125.1 AND ASME A112.18.2 / CSA B125.2, ADA COMPLIANT	CAST BRASS LAVATORY GRID DRAIN WITH 1-1/4" 17 GAUGE SEAMLESS BRASS OFFSET TAILPIECE. INTEGRAL PERFORATED GRID ASSEMBLY FOR WHEELCHAIR, CHROME FINISH, MOUNT P-TRAP FLUSH TO WALL.	COUNTER MOUNTED	1-1/2"	2"	1-1/2"	3/4"	1/2"	3/4"	1/2"
	L-2	LAVATORY WALL HUNG HOT AND COLD WATER ADA	*KOHLER* KINGSTON MODEL K-2006. ADA LAVATORY, WALL HUNG, VITREOUS CHINA WITH CONCEALED ARM RECESS, FRONT OVERFLOW, WITH SOAP DEPRESSION, 4" CENTERS, 20" x 18" D-SHAPED BOWL.	*T&S BRASS* MODEL B-2867-04-F05, 6" DECK MOUNT MIXING FAUCET, RIGID GOOSE NECK, 5 GPM NON-AERATED SPRAY DEVICE, COMPRESSION CARTRIDGES, 4" WRIST ACTION HANDLES, CHROME PLATED ESCUTCHEONS AND 1/2" NPSM MALE INLETS WITH COUPLING NUTS, CERTIFIED TO ASME A112.18.1 / CSA B125.1, NSF 61-SECTION 9 AND MEETS ADA ANSIVICC A117.1	CAST BRASS LAVATORY GRID DRAIN WITH 1-1/4" 17 GAUGE SEAMLESS BRASS OFFSET TAILPIECE. INTEGRAL PERFORATED GRID ASSEMBLY FOR WHEELCHAIR, CHROME FINISH, MOUNT P-TRAP FLUSH TO WALL.	MOUNT AT HEIGHT INDICATED ON ARCHITECTURAL DRAWINGS. PROVIDE "J.R. SMITH" #0700-M31 CONCEALED ARMS AND FLOOR SUPPORT, WITH FEET OF SUPPORT ANCHORED TO FLOOR. IN ADDITION, ANCHOR TOP OF SUPPORT TO WALL CONSTRUCTION.	1-1/2"	2"	1-1/2"	3/4"	1/2"	3/4"	1/2"
	SS-1	SERVICE SINK FLOOR MOUNTED HOT AND COLD WATER ADA	*ACORN* TCR-28, TERRAZZO-WARE, 28"x28"x12" DEEP, FLOOR MOUNTED, TERRAZZO, WITH STAINLESS STEEL CAP UNIT SHALL INCLUDE MODEL #818 HOSE WITH WALL HANGER, 8MM MOP HANGER WITH 2 SPRING LOADED GRIPS ON A STAINLESS STEEL BRACKET.	*T&S BRASS* MODEL B-0665-CR-BSTR, 8" WALL MOUNT MIXING FAUCET WITH ROUGH CHROME PLATED BODY, ROUGH CHROME PLATED BRASS SPOUT WITH VACUUM BREAKER, PAL HOOK AND GARDEN HOSE MALE OUTLET, CERAMIC CARTRIDGES WITH CHECK VALVES, LEVEL HANDLES, 1/2" NPT FEMALE INLETS, BUILT IN SERVICE COPS IN BODY AND UPPER SUPPORT ROD.			1-1/2"	3"	3"	3/4"	1/2"	3/4"	1/2"
	S-1	KITCHEN SINK COUNTER MOUNTED HOT AND COLD WATER ADA	*TELKAY* LRADQ312245, 31"x22"x4 1/2" DEEP, TOP MOUNT, 304 STAINLESS STEEL, LUSTERSTONE FINISH, 18 GAUGE, ADA COMPLIANT, PROVIDE WITH 3 HOLE - 4" ON CENTER FAUCET MOUNTING HOLES.	*TELKAY* UK1000CR EVERY DAY THREE HOLE FAUCET WITH LEVER CHROME FINISH, 1.5GPM, USER ADJUSTABLE TEMPERATURE CONTROL, VANDAL RESISTANT AERATOR.	17 GAUGE ADJUSTED P-TRAP CHROME PLATED, CHROME PLATED ANGLE VALVE AND ESCUTCHEONS, LOOSE KEY, CHICAGO 1017 JUST JY35 CUP STRAINER. GARBAGE DISPOSER: "IN-SINK-ERATOR" MODEL EVOLUTION ESSENTIAL, 3/4HP, 120V, 16, 60HZ, 8.1 AMP.		1-1/2"	2"	1-1/2"	3/4"	1/2"	3/4"	1/2"
	S-2	SINK COUNTER MOUNTED HOT AND COLD WATER ADA	*TELKAY* LRADQ312245, 19"x22"x5 1/2" DEEP, TOP MOUNT, 304 STAINLESS STEEL, LUSTERSTONE FINISH, 18 GAUGE, ADA COMPLIANT, PROVIDE WITH 3 HOLE - 4" ON CENTER FAUCET MOUNTING HOLES.	*TELKAY* UK1000CR EVERY DAY THREE HOLE FAUCET WITH LEVER CHROME FINISH, 1.5GPM, USER ADJUSTABLE TEMPERATURE CONTROL, VANDAL RESISTANT AERATOR.	17 GAUGE ADJUSTED P-TRAP CHROME PLATED, CHROME PLATED ANGLE VALVE AND ESCUTCHEONS, LOOSE KEY, CHICAGO 1017 JUST JY35 CUP STRAINER.		1-1/2"	2"	1-1/2"	3/4"	1/2"	3/4"	1/2"
	HB-1	HOSE BIBB	*ACORN* MODEL 8121-LF HOSE BIBB, BRASS CONSTRUCTION, VACUUM BREAKER, BENT NOSE WITH FLANGE.			FOR INTERIOR WALL MOUNTING INSTALLATION	-	-	-	3/4"	1/2"	-	-
	FD-1	FLOOR DRAIN	*J.R. SMITH* MODEL 2010 CPHU-TT-BB		6" ROUND POLISHED NICKEL BRONZE STRAINER	PROVIDE FLASHING RING AND CLAMP AT FLOORS WITH WATER RESISTANT MEMBRANE. SET TOP OF DRAIN SLIGHTLY BELOW FLOOR TO INSURE DRAINAGE. INSTALL VENTED P-TRAP WHERE TRAP PRIMERS ARE INDICATED. PROVIDE PROPER CONNECTION TO P-TRAP.	2"	2" 3" 4"	2" 3" 4"	-	-	-	-
	FCO	FLOOR CLEAN OUT	*J.R. SMITH* MODEL 4024S-U-PB FINISHED FLOOR CLEAN OUT WITH TWIS-TO-FLOOR ADJUSTABLE TOP		PROVIDE WITH VANDAL PROOF, POLISHED BRONZE TOP		2"	2" 3" 4"	2" 3" 4"	-	-	-	-
	DF-1	DRINKING FOUNTAIN	*TELKAY* MODEL EDPF214C, STAINLESS STEEL, WALL MOUNTED STAINLESS STEEL BACK PANEL, FLEXI-GUARD BUBBLER.	PROVIDE WITH P-TRAP.	PROVIDE MANUFACTURER'S INTERNAL SUPPORT SYSTEM. SET AT HEIGHT INDICATED ON ARCH DRAWINGS.		1-1/2"	2"	1-1/2"	3/4"	1/2"	-	-
	DF-2	DRINKING FOUNTAIN	*TELKAY* MODEL EDPF214C, STAINLESS STEEL, WALL MOUNTED STAINLESS STEEL BACK PANEL, FLEXI-GUARD BUBBLER.	PROVIDE WITH P-TRAP.	PROVIDE MANUFACTURER'S INTERNAL SUPPORT SYSTEM. SET AT HEIGHT INDICATED ON ARCH DRAWINGS.		1-1/2"	2"	1-1/2"	3/4"	1/2"	-	-
	TP-1	TRAP PRIMER	*MIFAB* MR-500-NPB SERIES, PRESSURE DROP ACTIVATED TRAP SEAL PRIMER, WITH 1/2" MALE NPT INLET AND 1/2" FEMALE NPT OUTLET, COMPLETE WITH FOUR VIEW HOLES AND REMOVABLE FILTER SCREEN.		PROVIDE WITH "MIFAB" M-DU TRAP SEAL PRIMER DISTRIBUTION UNIT WITH FOUR 3/8" FPT BRASS NIPPLE OUTLET CONNECTIONS TO SERVE EITHER 2, 3, OR 4 FLOOR DRAIN TRAPS AND 1/2" MPT INLET CONNECTION. UNIT COMPLETE WITH FOUR 1/4" DIAMETER VENT HOLES IN THE LID AND THREE 1/8" DIAMETER PHILLIPS HEAD SCREWS TO SECURE THE LID TO THE BODY.		-	-	-	1/2"	1/2"	-	-
	WHA	WATER HAMMER ARRESTOR	*SIQUY CHEF* HYDRARESTOR, TYPE L, COPPER, MIP CONNECTOR 250°F MAX WORKING TEMPERATURE, 350 PSIG MAX WORKING PRESSURE, LAB TESTED TO 10,000 CYCLES, FACTORY TESTED TO 500,000 CYCLES WITHOUT FAILURE (MODEL 654-C TESTED)		PROVIDE WITH POLISHED BRONZE TOP	SIZE VARIES. SEE 3/P501 FOR INSTALLATION AND SIZING CHART	-	-	-	-	-	-	-

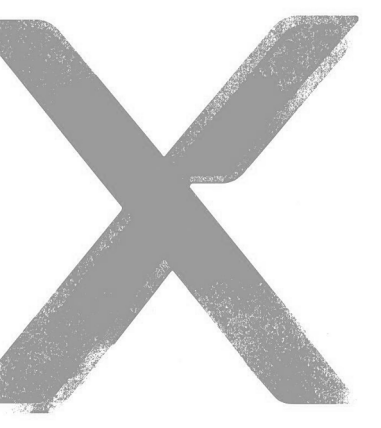

ARCH | NEXUS

Architectural NEXUS, Inc.  
930 R Street  
Sacramento, California 95811  
T 916.443.5911  
http://www.archnexus.com

Original drawings remain the property of the Architect and as such the Architect retains total ownership and control. The design represented by these drawings is sold to the client for a one time use, unless otherwise agreed upon in writing by the Architect. © Architectural Nexus, Inc. 2014



EL DORADO COUNTY  
EDC HHS TENANT IMPROVEMENT  
3368 SANDY WAY  
SOUTH LAKE TAHOE, CA 96150



DATE SIGNED: 1-02-19  
# Date Revision

CONSTRUCTION DOCUMENTS

NEXUS PROJ. #: 18117  
CHECKED BY: Checker  
DRAWN BY: Author  
DATE: 01.02.2019

PLUMBING SCHEDULES

E

D

C

B

A

1/2/2019 11:45:29 AM



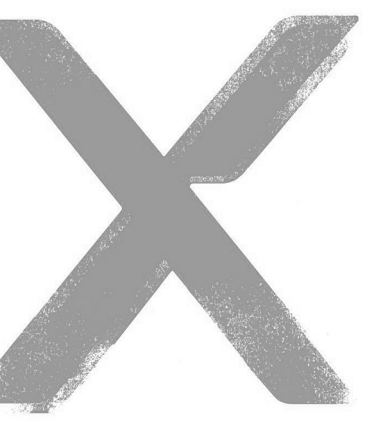

ARCH | NEXUS

Architectural NEXUS, Inc.  
930 R Street  
Sacramento, California 95811  
T 916.443.5911  
http://www.archnexus.com

Original drawings remain the property of the Architect and as such the Architect retains total ownership and control. The design represented by these drawings is sold to the client for a one time use, unless otherwise agreed upon in writing by the Architect. © Architectural Nexus, Inc. 2014

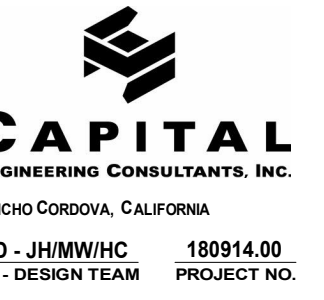

EL DORADO COUNTY  
**EDC HHS TENANT IMPROVEMENT**  
3368 SANDY WAY  
SOUTH LAKE TAHOE, CA 96150



DATE SIGNED: 1-02-19  
# Date Revision

**CONSTRUCTION DOCUMENTS**

NEXUS PROJ. #: 18117  
CHECKED BY: Checker  
DRAWN BY: Author  
DATE: 01.02.2019

**PLUMBING DEMO PLAN**

**P100**  
18-1912 Revised B 105 of 606  
BOS Rcvd 1-24-19

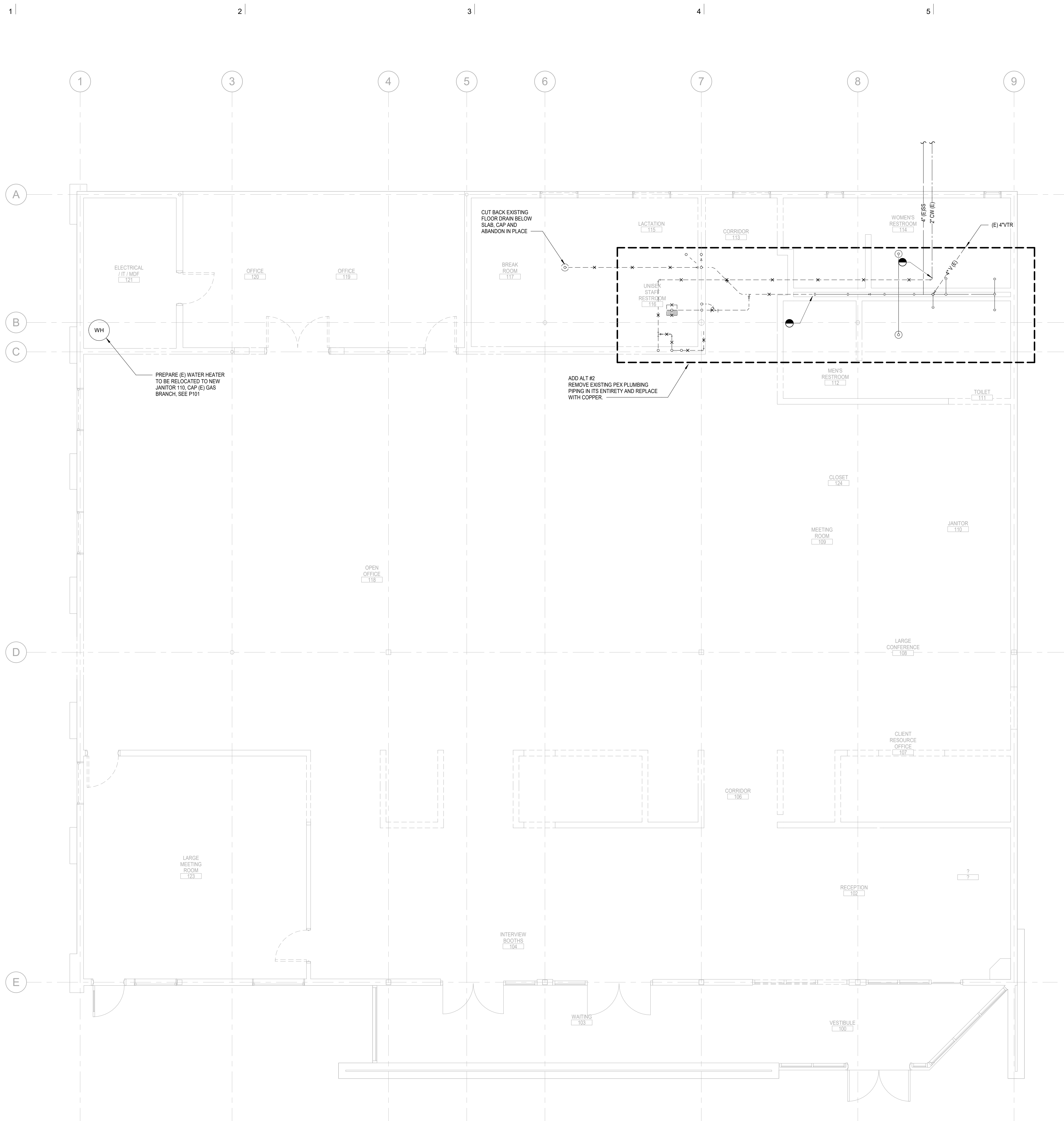

**1 PLUMBING DEMO PLAN**  
SCALE: 1/4" = 1'-0"  
N

1/2/2019 11:45:30 AM

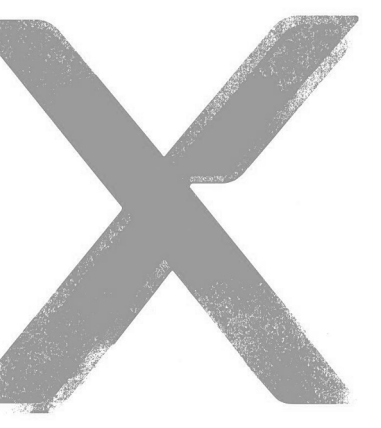

ARCH | NEXUS

Architectural NEXUS, Inc.  
930 R Street  
Sacramento, California 95811  
T 916.443.5911  
http://www.archnexus.com

Original drawings remain the property of the Architect and as such the Architect retains total ownership and control. The design represented by these drawings is sold to the client for a one time use, unless otherwise agreed upon in writing by the Architect. © Architectural Nexus, Inc. 2014



EL DORADO COUNTY  
**EDC HHS TENANT IMPROVEMENT**  
3368 SANDY WAY  
SOUTH LAKE TAHOE, CA 96150

KEYNOTES:

RELOCATED (E) WH

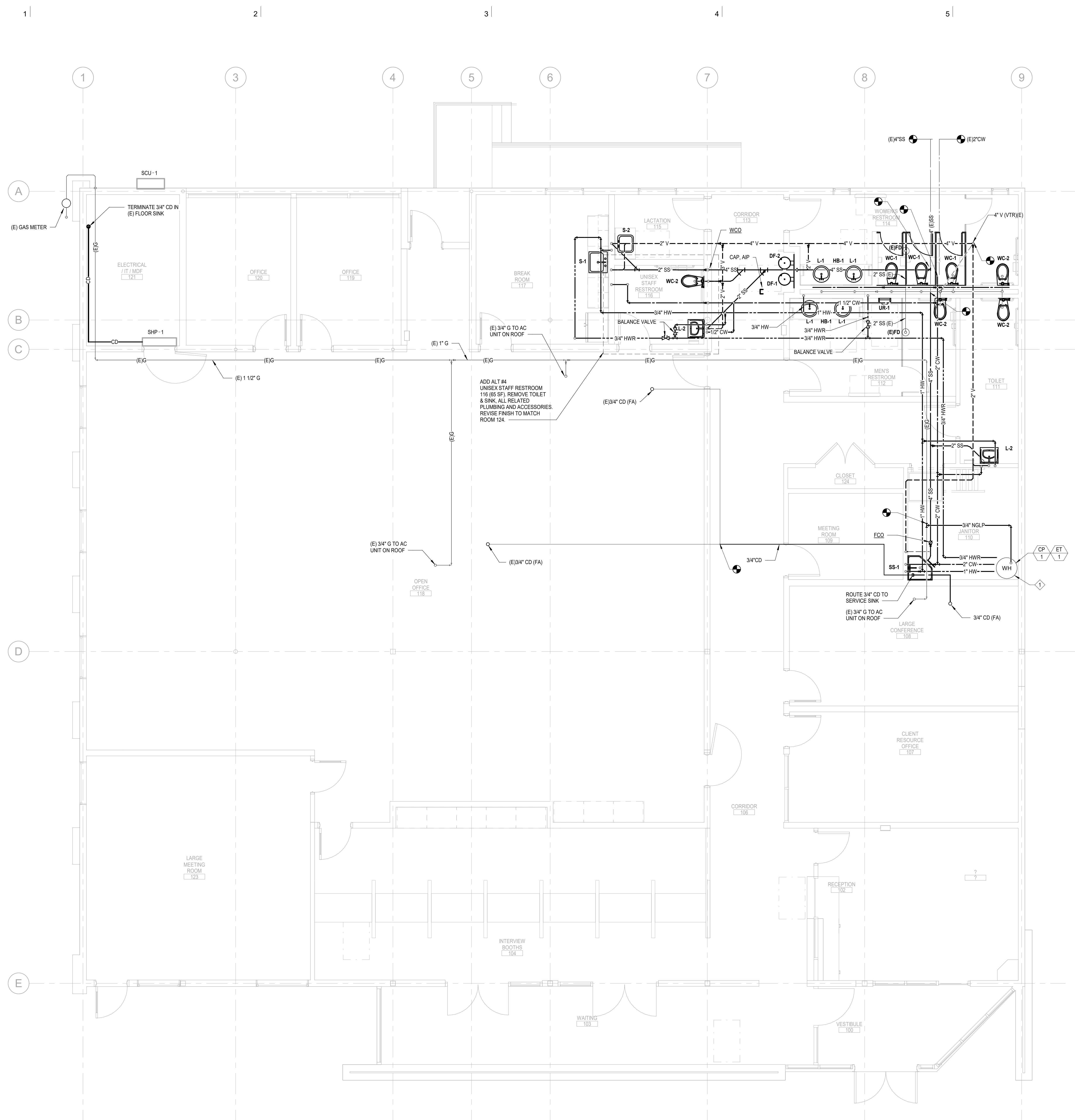

1 PLUMBING FLOOR PLAN  
P101 SCALE: 1/4" = 1'-0" N



DATE SIGNED: 1-02-19  
# Date Revision

CONSTRUCTION DOCUMENTS

NEXUS PROJ. #: 18117  
CHECKED BY: Checker  
DRAWN BY: Author  
DATE: 01.02.2019

PLUMBING FLOOR PLAN

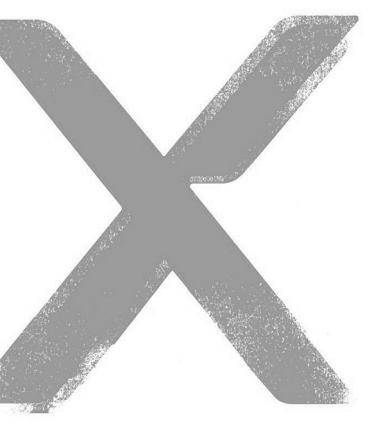

ARCH | NEXUS

Architectural NEXUS, Inc.  
930 R Street  
Sacramento, California 95811  
T 916.443.5911  
http://www.archnexus.com

Original drawings remain the property of the Architect and as such the Architect retains total ownership and control. The design represented by these drawings is sold to the client for a one time use, unless otherwise agreed upon in writing by the Architect. © Architectural Nexus, Inc. 2014



EL DORADO COUNTY  
**EDC HHS TENANT IMPROVEMENT**  
3368 SANDY WAY  
SOUTH LAKE TAHOE, CA 96150



DATE SIGNED: 1-02-19  
# Date Revision

**CONSTRUCTION DOCUMENTS**

NEXUS PROJ. #: 18117  
CHECKED BY: Checker  
DRAWN BY: Author  
DATE: 01.02.2019

**PLUMBING DETAILS**

**P500**  
18-1912 Revised B 107 of 606  
BOS Revd 1-24-19

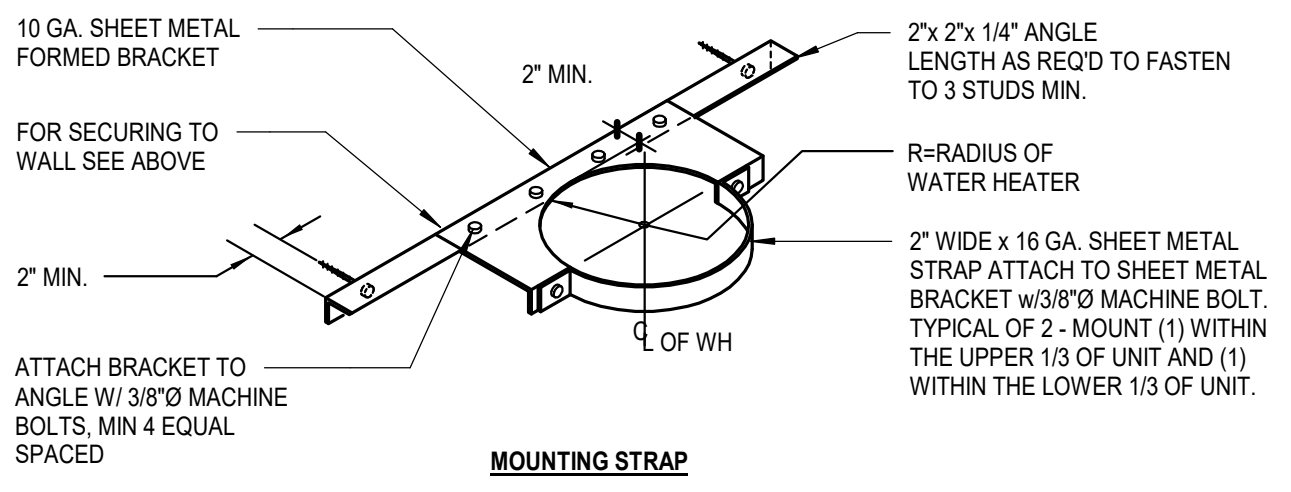
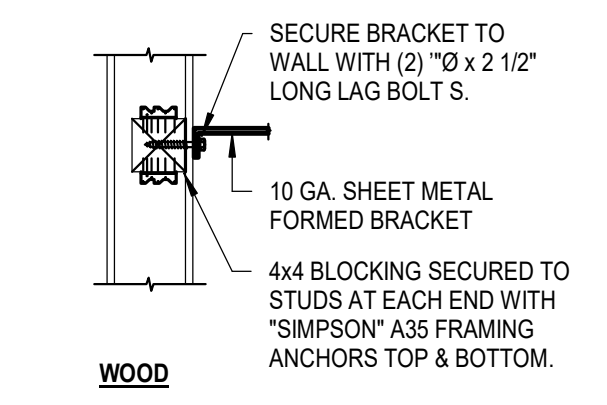

**4 WATER HEATER STRAP MOUNTING**  
SCALE: NOT TO SCALE

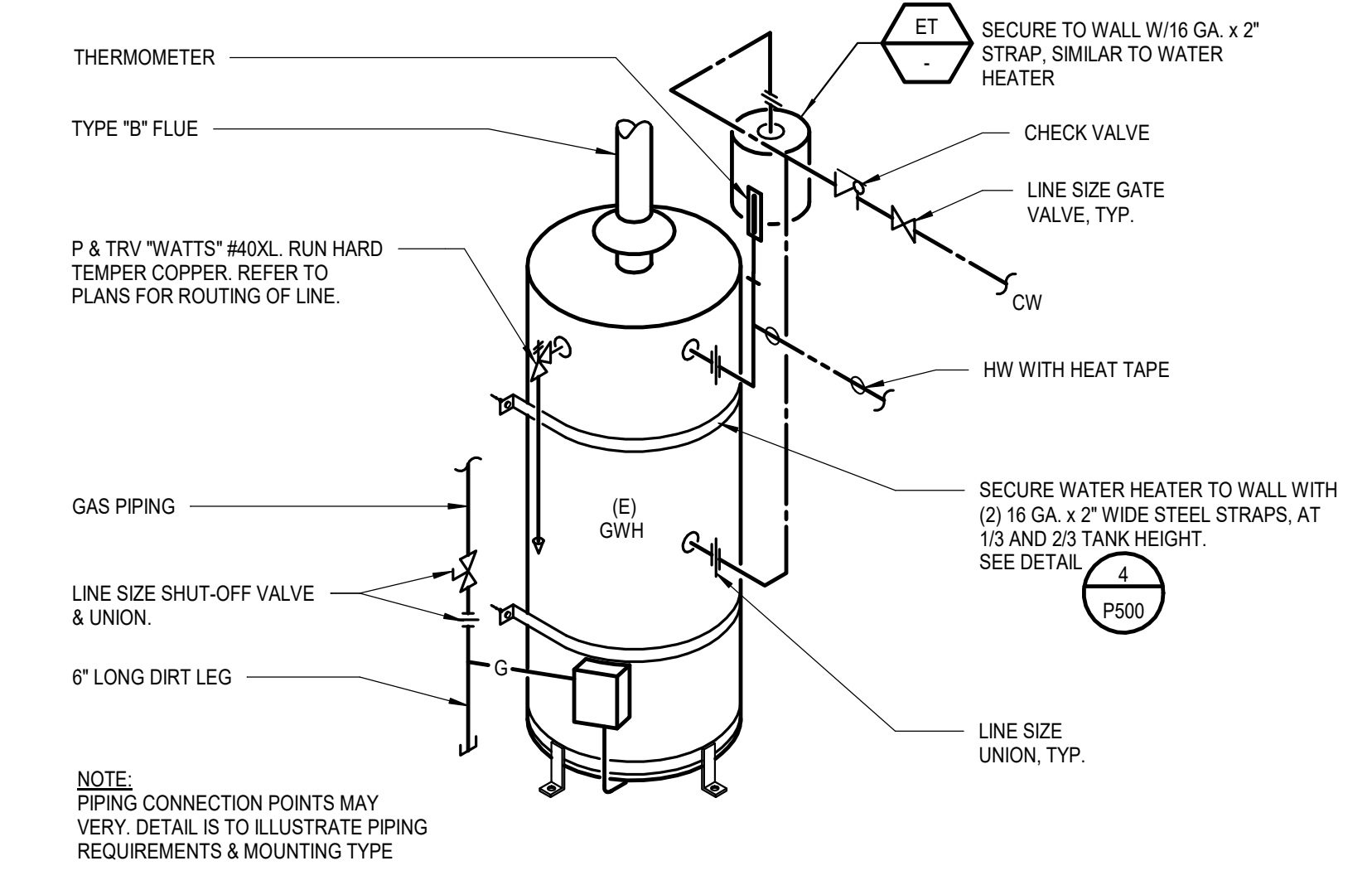

**1 GWH**  
SCALE: NOT TO SCALE

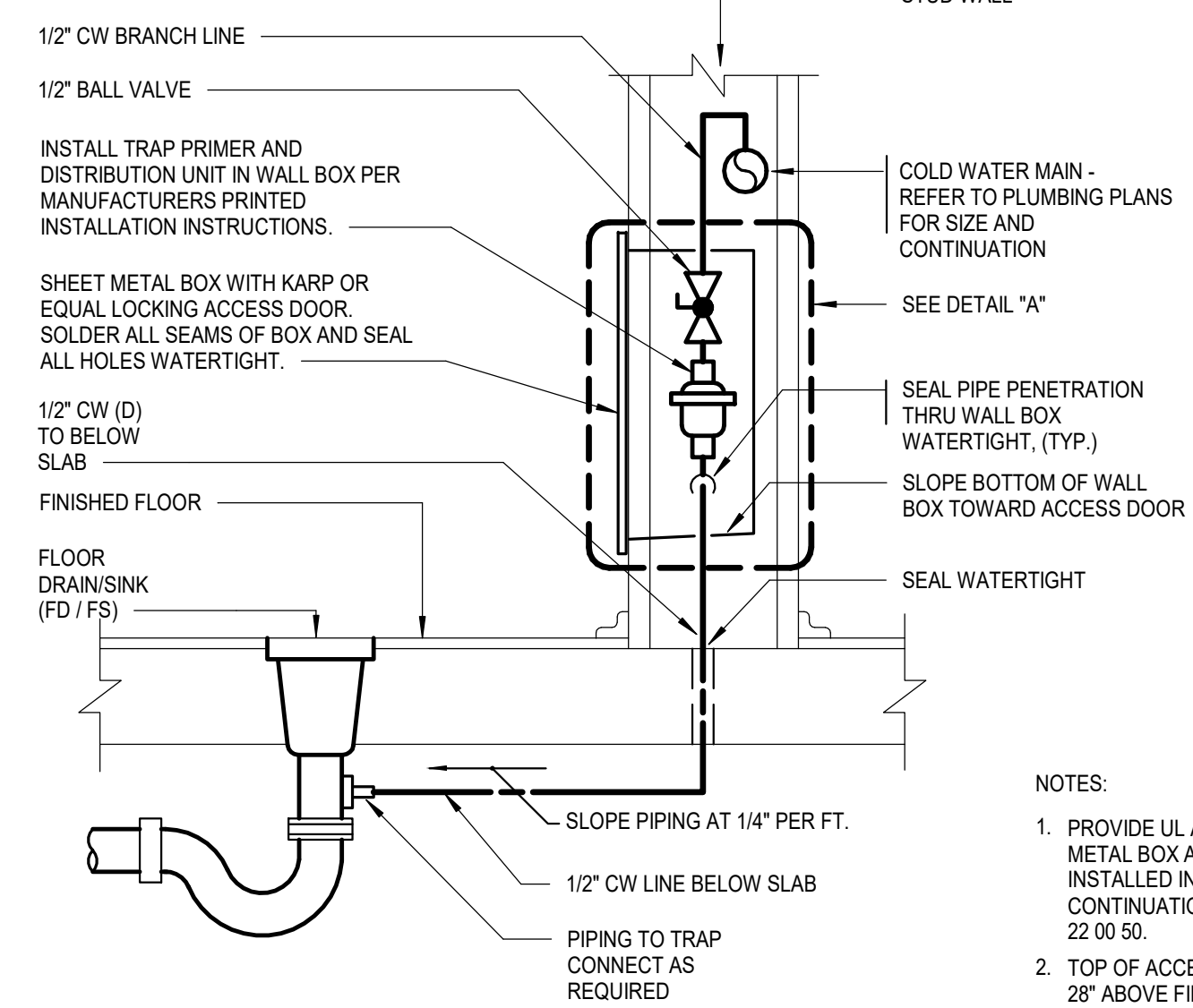
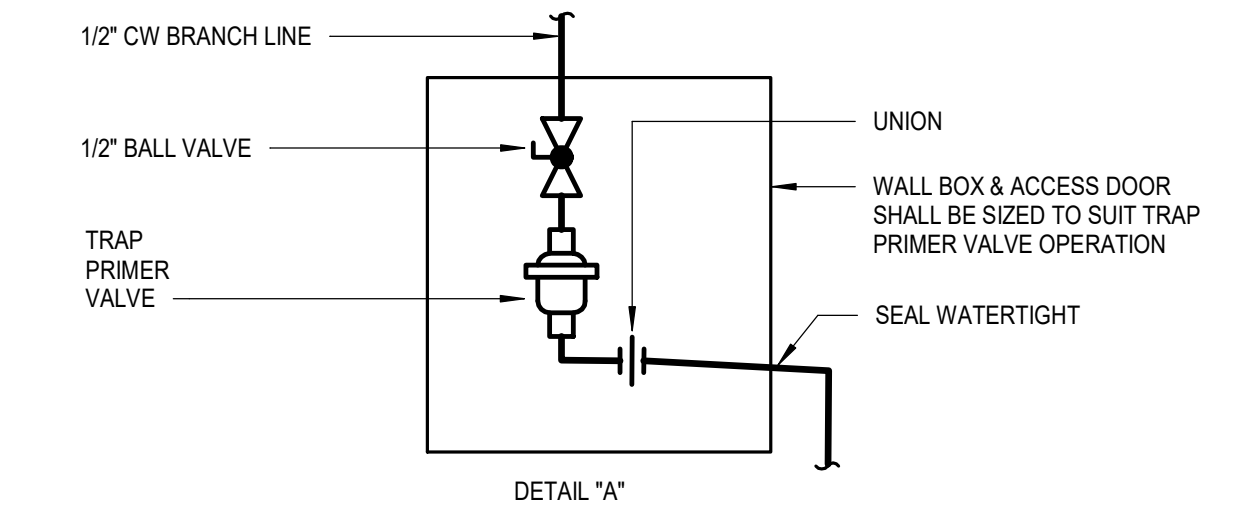

**2 TRAP PRIMER TO FLOOR DRAIN**  
SCALE: NOT TO SCALE

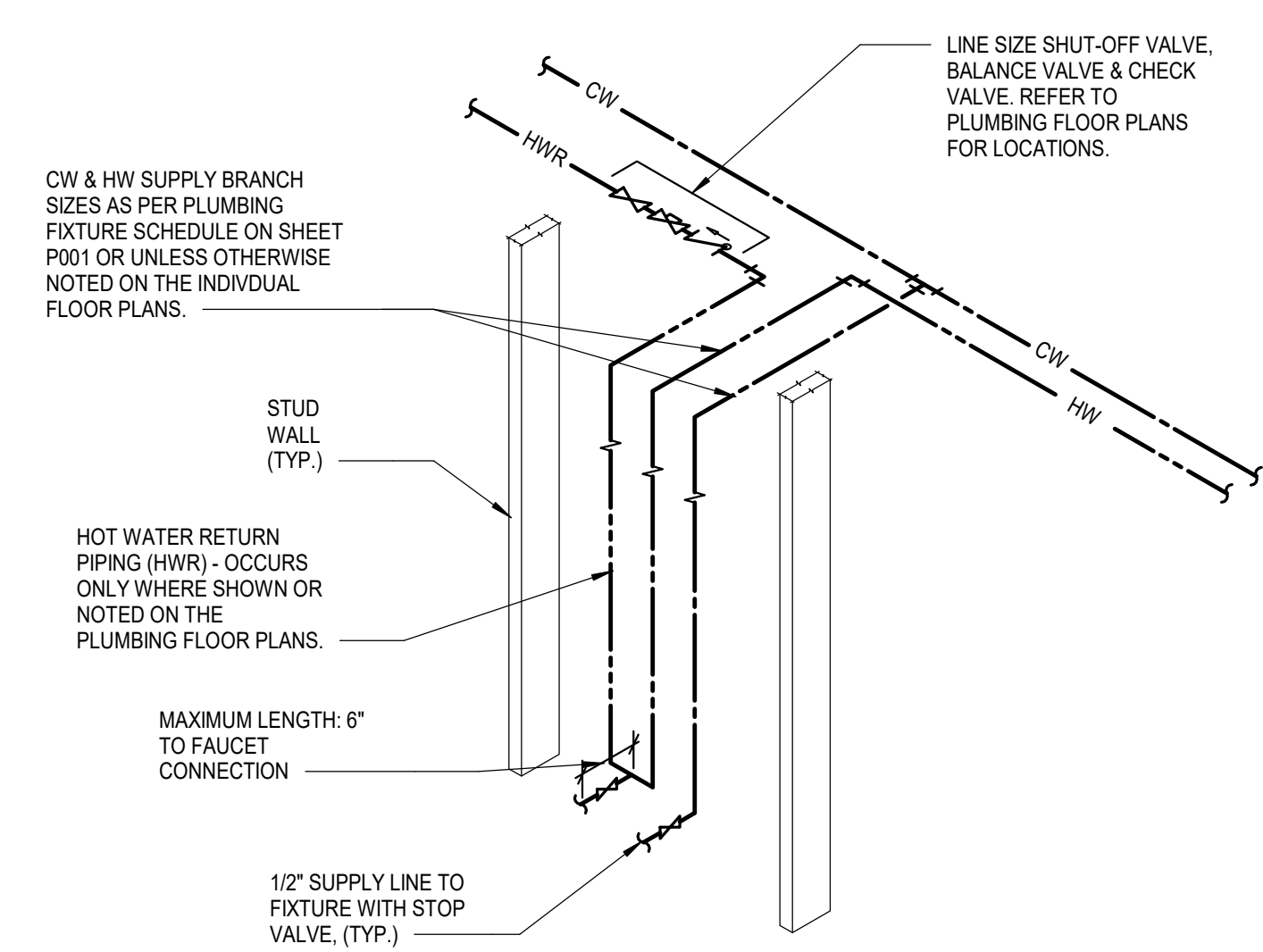

**3 HOT WATER RETURN PIPE**  
SCALE: NOT TO SCALE

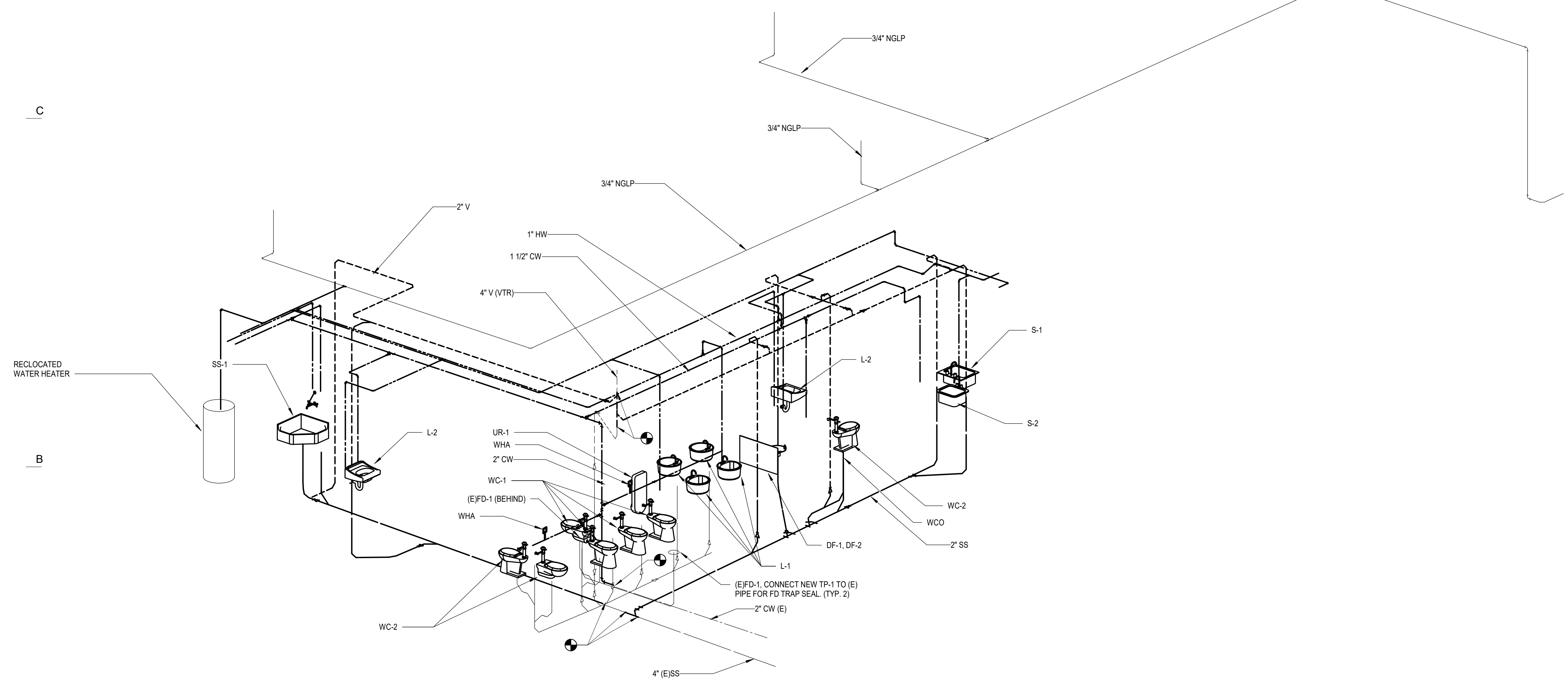

**5 PLUMBING RISER DIAGRAM**  
SCALE:

1/2/2019 11:45:32 AM



ARCH | NEXUS  
 Architectural NEXUS, Inc.  
 930 R Street  
 Sacramento, California 95811  
 T 916.443.5911  
 http://www.archnexus.com

Original drawings remain the property of the Architect and as such the Architect retains total ownership and control. The design represented by these drawings is sold to the client for a one time use, unless otherwise agreed upon in writing by the Architect.  
 © Architectural Nexus, Inc. 2014

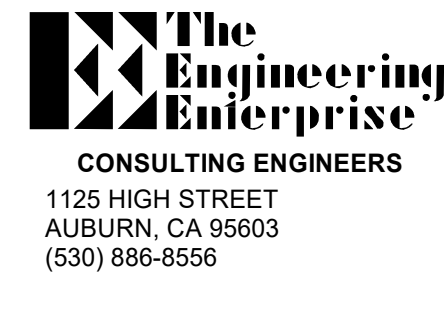

EL DORADO COUNTY  
**EDC HHS TENANT IMPROVEMENT**  
 3368 SANDY WAY  
 SOUTH LAKE TAHOE, CA 96150

PROFESSOR OF ARCHITECTURE  
 ANDRÉ J. BELL  
 ARCHITECT  
 1225 HIGH STREET  
 AUBURN, CA 95603  
 (530) 896-8556

# Date Revision

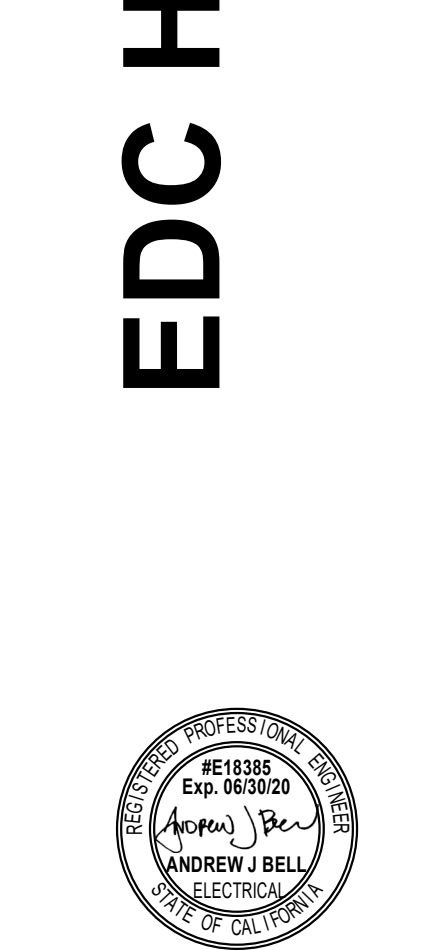

**CONSTRUCTION DOCUMENTS**  
 NEXUS PROJ. #: 18117  
 CHECKED BY: Author  
 DRAWN BY: Andrew Bell  
 DATE: 01/02/2019

**SYMBOLS, ABBREVIATIONS AND SHEET INDEX**

**E000**  
 18-1912 Revised B 105 of 606  
 BOS Rcvd 1-24-19

ABBREVIATIONS	
A	AMPERES
AFI	ARC FAULT CIRCUIT INTERRUPTER
AF	AMPERE OVERCURRENT FRAME SIZE (WHEN APPLIED TO CIRCUIT BREAKERS) OR AMPERE FUSE SIZE (WHEN APPLIED TO FUSES)
AFB	ABOVE FINISHED FLOOR
AIC	ASYMMETRIC INTERRUPTING CURRENT
AL	ALUMINUM
AT	AMPERE OVERCURRENT TRIP (WHEN APPLIED TO CIRCUIT BREAKERS)
ATS	AUTOMATIC TRANSFER SWITCH
BAS	BUILDING AUTOMATION SYSTEM
BPS	BOLTED PRESSURE CONTACT SWITCH
C	CONDUIT
CCTV	CLOSED CIRCUIT TELEVISION
CEC	CALIFORNIA ELECTRICAL CODE
CL	CURRENT LIMITING CIRCUIT BREAKER OR FUSE
CP	CIRCULATION PUMP
CT	CURRENT TRANSFORMER
CU	COPPER
DF	DRINKING FOUNTAIN
DW	DISH WASHER
(E)	EXISTING TO REMAIN
EC	ELECTRICAL CONTRACTOR
EF	EXHAUST FAN
EP	EXPLOSION PROOF
EPO	EMERGENCY POWER OFF
EMCS	ENERGY MANAGEMENT CONTROLS SYSTEM
EMT	ELECTRICAL METALLIC TUBING
ETD	EMERGENCY TRANSFER DEVICE
EW	ELECTRIC WATER HEATER
F	FUSED
(F)	FUTURE
FACP	FIRE ALARM CONTROL PANEL
FFCP	FIREMAN'S FAN CONTROL PANEL
FLA	FULL LOAD AMPERES
FMC	FLEXIBLE METAL CONDUIT
FSD	FIRE/SMOKE DAMPER
FRAP	FIREMAN'S REMOTE ANNUNCIATOR PANEL
G	GROUND
GB	GROUND BUS
GD	GARBAGE DISPOSAL
GFCI	GROUND FAULT CIRCUIT INTERRUPTER
GND	GROUND
GRAP	GENERATOR REMOTE ANNUNCIATOR PANEL
HNC	HOME NETWORK CABINET
HPC	HIGH PRESSURE CONTACT SWITCH
IMC	INTERMEDIATE METAL CONDUIT
IWH	INSTANTANEOUS OR POINT OF USE WATER HEATER
LCP	LIGHTING CONTROL PANEL
MBGB	MAIN BUILDING GROUND BUS
MCB	MAIN CIRCUIT BREAKER
MCC	MOTOR CONTROL CENTER
MLO	MAIN LUGS ONLY
MT	EMPTY
MTC	EMPTY CONDUIT
MTS	MANUAL TRANSFER SWITCH
MW	MICROWAVE
(N)	NEW
NC	NORMALLY CLOSED
NF	NON-FUSED
NIEC	NOT IN ELECTRICAL CONTRACT
NO	NORMALLY OPEN
NTS	NOT TO SCALE
OC	ON CENTER
OCFI	OWNER FURNISHED CONTRACTOR INSTALLED
POZ	PRIMARY DAYLIGHT ZONE
PNL	PANEL
PT	POTENTIAL TRANSFORMER
PVC	POLYVINYL CHLORIDE
RF	REFRIGERATOR
(R)	EXISTING TO BE REMOVED
(RR)	REMOVE AND RELOCATE
RGB	REFERENCE GROUND BUS
RSC	RIGID STEEL CONDUIT
SAD	SEE ARCHITECTURAL DRAWINGS
TC	TIME CLOCK
TP	TWISTED-PAIR
SDZ	SECONDARY DAYLIGHT ZONE
SPD	SURGE PROTECTION DEVICE
TX	TRANSFORMER
TYP	TYPICAL
UON	UNLESS OTHERWISE NOTED
UPS	UNINTERRUPTIBLE POWER SUPPLY
UR	UNDERCOUNTER REFRIGERATOR
V	VOLTS
VA	VOLTS-AMPS
VPD	VARIABLE FREQUENCY DRIVE
VM	VENDING MACHINE
WAP	WIRELESS ACCESS POINT
WP	WEATHERPROOF
2SP	TWO SPEED
1Ø	1 PHASE
3Ø	3 PHASE
1P	1 POLE
2P	2 POLE
3P	3 POLE
3W	3 WIRE
4W	4 WIRE

RACEWAYS	
---	CONDUIT RUN EXPOSED ON WALL OR CEILING.
---	CONDUIT RUN CONCEALED IN SLAB, UNDER SLAB OR UNDERGROUND.
---	CONDUIT RUN CONCEALED IN WALL OR ABOVE CEILING.
---	CONDUIT HOMERUN, CONTINUOUS RUN TO PANEL OR EQUIPMENT CABINET.
---	CONDUIT
---	FLEXIBLE METALLIC CONDUIT.
---	CONDUIT TURNED UP
---	CONDUIT TURNED DOWN.
---	CONDUIT CAPPED OR STUBBED WITH INSULATED BUSHINGS.
---	CONDUIT SLEEVE, WITH INSULATING BUSHINGS.
---	CROSSMARKS ON BRANCH CIRCUIT CONDUIT RUNS INDICATE THE QUANTITY OF CONDUCTORS AS FOLLOWS (GROUND CONDUCTORS ARE NOT NOTED, BUT SHOULD BE INCLUDED IN EVERY CONDUIT WITH POWER CONDUCTORS): 1. NO CROSSMARKS INDICATES TWO #12 AWG CONDUCTORS, UON. 2. THREE TO SIX CROSSMARKS INDICATES THE QUANTITY OF #12 AWG CONDUCTORS, UON. 3. SEVEN OR MORE CROSSMARKS INDICATES THE QUANTITY OF #10 AWG CONDUCTORS, UON.
---	MULTI-OUTLET TWO PIECE SURFACE RACEWAY; TYPE, DEVICE SPACING AND MOUNTING AS NOTED ON PLANS.
---	TWO PIECE SURFACE METAL RACEWAY, MOUNTED AS NOTED IN PLANS.
---	CABLE TRAY, CABLE RUNWAY OR LADDER RACK SUSPENDED FROM STRUCTURE ABOVE. REFER TO PLANS FOR SIZE AND MOUNTING.
---	FLOOR DUCT

SHEET INDEX	
SHEET NO.	SHEET NAME
E000	SYMBOLS, ABBREVIATIONS AND SHEET INDEX
E001	PROJECT NOTES AND SCHEDULES
E002	LOW VOLTAGE INSTRUCTIONS & SPECS
E003	TITLE 24
E100	DENIG PLAN
E200	LIGHTING PLAN
E300	POWER & SIGNAL PLAN
E301	POWER & SIGNAL PLAN - ROOF
E400	FIRE ALARM PLAN
E500	POWER ONE-LINE DIAGRAM
E501	RISER DIAGRAMS
E601	DETAILS

TELECOMMUNICATIONS	
⊠	TELECOMMUNICATION DEVICE, WALL MOUNTED, +18" UON, 2 DROPS U.O.N.
⊠	TELECOMMUNICATION DEVICE, WALL MOUNTED OVER COUNTER, 6" ABOVE BACK SPLASH, UON, 2 DROPS U.O.N.
⊠	TELECOMMUNICATION DEVICE, MOUNTED IN FLUSH FLOOR BOX.
⊠	TELECOMMUNICATION DEVICE, MOUNTED IN FIRE-RATED POKE-THRU FLOOR FITTING.
⊠	TELECOMMUNICATION DEVICE, MOUNTED IN FLOOR MONUMENT.
⊠	TELECOMMUNICATION DEVICE, MOUNTED ABOVE ACCESSIBLE CEILING IN SURFACE MOUNT BOX.
⊠	COMBINATION POWER/TELECOMMUNICATION DEVICES, MOUNTED IN FLUSH FLOOR BOX, TYPE AS NOTED ON PLANS OR IN SPECIFICATIONS.
⊠	COMBINATION POWER/TELECOMMUNICATION DEVICES, MOUNTED IN FIRE-RATED POKE-THRU FLOOR FITTINGS, TYPE AS NOTED ON PLANS OR IN SPECIFICATIONS.
⊠	ELECTRIFIED FURNITURE PARTITION TELECOMMUNICATION CABLE FEED, WALL MOUNTED, +18" UON, CONSISTS OF 4 1 1/16" SQ. X 2 1/8" DEEP JUNCTION BOX, SINGLE GANG RING, AND STAINLESS STEEL COVERPLATE WITH 1 1/4" KO AND GROMMET. WRAP EXPOSED CABLE WITH SPIRAL WRAP.
⊠	ELECTRIFIED FURNITURE PARTITION COMBINATION POWER/TELECOMMUNICATION FEEDS, MOUNTED IN FLUSH FLOOR BOX WITH KO'S IN COVERS TO ACCEPT FURNITURE WHIPS. TELECOMMUNICATIONS WHIP SHALL BE 1 1/4" MINIMUM.
⊠	ELECTRIFIED FURNITURE PARTITION TELECOMMUNICATION CABLE FEEDS, MOUNTED IN FIRE-RATED POKE-THRU THRU FLOOR FITTING WITH 1 1/4" KO'S IN COVER TO ACCEPT FURNITURE WHIPS.
⊠	WIRELESS ACCESS POINT, WALL MOUNTED, 8" BFUC UON.
⊠	WIRELESS ACCESS POINT, CEILING MOUNTED.
⊠	QUANTITY OF DATA AND/OR VOICE TELECOMMUNICATIONS DEVICES.

SECURITY	
⊠	ALARM MONITORING CONTACT, MOUNTED AS NOTED ON PLANS.
⊠	ELECTRIC MORTISE DOOR LOCK, NIC, BUT WIRED UNDER THIS DIVISION.
⊠	ELECTRIC DOOR STRIKE, NIC, BUT WIRED UNDER THIS DIVISION.
⊠	ELECTROMAGNETIC DOOR LOCK, NIC, BUT WIRED UNDER THIS DIVISION.
⊠	ELECTRIFIED PANIC HARDWARE, NIC, BUT WIRED UNDER THIS DIVISION.
⊠	MECHANICAL PANIC HARDWARE, NIC, BUT WIRED UNDER THIS DIVISION.
⊠	REQUEST-TO-EXIT SWITCH, NIC, FURNISH WITH DOOR HARDWARE AND WIRED UNDER THIS DIVISION.
⊠	POWER TRANSFER HINGE, NIC.
⊠	DOOR RELEASE MOTION SENSOR, WALL OR CEILING MOUNTED ABOVE DOOR, UON.
⊠	DURESS STATION, MOUNTED AS NOTED ON PLANS.
⊠	AREA MOTION SENSOR, CEILING MOUNTED, UON.
⊠	AREA MOTION SENSOR WITH SOUND RECORDING, CEILING MOUNTED, UON.
⊠	AREA MOTION SENSOR, WALL MOUNTED, +36" UON.
⊠	GLASS BREAK DETECTOR, CEILING MOUNTED, UON.
⊠	CARD READER CONTROLLER, WALL MOUNTED, +36" UON.
⊠	KEY PAD CONTROLLER, WALL MOUNTED, +42" UON.
⊠	REMOTE MOUNTED POWER SUPPLY FOR LOW-VOLTAGE EQUIPMENT CONNECTIONS.
⊠	FIXED POSITION CCTV CAMERA, MOUNTED AS NOTED ON PLANS.
⊠	PAN/TILT/ZOOM (PTZ) CCTV CAMERA, MOUNTED AS NOTED ON PLANS.
⊠	CCTV MONITOR.

DAS	
⊠	ZINWAVE REMOTE UNIT
⊠	Rx OMNI ANTENNA
⊠	Tx OMNI ANTENNA

SYMBOLS LIST	
LIGHTING	
⊠	LIGHT FIXTURE, RECESSED IN CEILING.
⊠	LIGHT FIXTURE, SURFACE OR PENDANT MOUNTED.
⊠	LIGHT FIXTURE, WALL MOUNTED.
⊠	STRIP LIGHT FIXTURE, SURFACE OR PENDANT MOUNTED.
⊠	STRIP LIGHT FIXTURE, SURFACE MOUNTED IN ARCHITECTURAL CEILING COVE.
⊠	STRIP LIGHT FIXTURE, SURFACE MOUNTED VERTICALLY ON WALL OR IN COVE.
⊠	ROUND DOWNLIGHT FIXTURE, RECESSED IN CEILING.
⊠	SQUARE DOWNLIGHT FIXTURE, RECESSED IN CEILING.
⊠	DOWNLIGHT/INDUSTRIAL FIXTURE, SURFACE OR PENDANT MOUNTED.
⊠	ADJUSTABLE LIGHT FIXTURE, RECESSED IN CEILING.
⊠	ADJUSTABLE LIGHT FIXTURE, SURFACE OR PENDANT MOUNTED.
⊠	LINEAR, MULTI-HEAD, ADJUSTABLE ACCENT LIGHT FIXTURES, RECESSED IN CEILING.
⊠	SINGLE DIRECTIONAL, WALLWASH LIGHT FIXTURE, RECESSED IN CEILING.
⊠	DUAL DIRECTIONAL, WALLWASH LIGHT FIXTURE, RECESSED IN CEILING.
⊠	SINGLE DIRECTIONAL, WALLWASH LIGHT FIXTURE, SURFACE OR PENDANT MOUNTED.
⊠	DUAL DIRECTIONAL, WALLWASH LIGHT FIXTURE, SURFACE OR PENDANT MOUNTED.
⊠	LINEAR WALLWASH LIGHT FIXTURE, RECESSED IN CEILING.
⊠	LINEAR WALLWASH LIGHT FIXTURE, SURFACE OR PENDANT MOUNTED.
⊠	SCONCE LIGHT FIXTURE, WALL MOUNTED.
⊠	DECORATIVE CHANDELIER OR BOWL TYPE FIXTURE, PENDANT MOUNTED.
⊠	EXIT SIGN LIGHT FIXTURE, CEILING OR WALL MOUNTED WITH DIRECTIONAL ARROWS AS NOTED ON PLANS. WORD 'EXIT' TO BE LOCATED IN SHADED FACES).
⊠	COMBOS EXIT SIGN AND EGRESS LIGHTING FIXTURE, CEILING OR WALL MOUNTED WITH ARROWS AS NOTED ON PLANS OR IN FIXTURE SCHEDULE.
⊠	EMERGENCY SELF-POWERED BATTERY PACK WITH LIGHT FIXTURE HEADS AS NOTED ON PLANS OR IN FIXTURE SCHEDULE.
⊠	FULL SHADING OF ANY FIXTURE INDICATES STANDBY/CRITICAL LIGHTING.
⊠	SINGLE-HEAD AREA LIGHT FIXTURE WITH BRACKET ARM AND POLE, MOUNTED TO CONCRETE BASE.
⊠	TWO-HEAD AREA LIGHT FIXTURES WITH BRACKET ARMS AND POLE, MOUNTED TO CONCRETE BASE.
⊠	SINGLE-HEAD AREA POST-TOP LIGHT FIXTURE WITH POLE, MOUNTED TO CONCRETE BASE.
⊠	AREA LIGHT FIXTURE, SURFACE OR RECESSED MOUNTED TO WALL.
⊠	LIGHT FIXTURE BOLLARD, MOUNTED TO CONCRETE BASE.
⊠	GROUNDWELL MOUNTED FLUSH IN FINISHED GRADE.
⊠	FLOODLIGHT FIXTURE, STANCHION MOUNTED ABOVE GRADE.
⊠	LINEAR SIGN LIGHT FIXTURE, STANCHION MOUNTED ABOVE GRADE.
⊠	STEPLIGHT FIXTURE, WALL MOUNTED.
⊠	MULTIPLE FIXTURES MOUNTED ON COMMON POLE.
⊠	F.A.A OBSTRUCTION LIGHT.

FIRE ALARM	
⊠	SMOKE DETECTOR INITIATING DEVICE, CEILING MOUNTED ON FLUSH OR SURFACE JUNCTION BOX.
⊠	SMOKE DETECTOR INITIATING DEVICE, STRUCTURE MOUNTED ABOVE SUSPENDED CEILING TO SURFACE JUNCTION BOX.
⊠	SMOKE DETECTOR INITIATING DEVICE, DUCT-MOUNTED TYPE WITH SAMPLING TUBE, LOCATED AT SUPPLY AIR FANS 2000cfm AND LARGER.
⊠	SMOKE DETECTOR INITIATING DEVICE, IN-DUCT MOUNTED TYPE AT, DUCTED FSD'S.
⊠	PROJECTED BEAM SMOKE DETECTOR INITIATING DEVICES TO INCLUDE BTR-TRANSMITTER, RECEIVER AND REMOTE INDICATOR STATION, WALL OR PENDANT MOUNTED IN FLUSH OR SURFACE JUNCTION BOX AS NOTED ON PLANS. BT-BEAM TRANSMITTER, BR-BEAM RECEIVER.
⊠	HEAT DETECTOR INITIATING DEVICE, CEILING MOUNTED ON FLUSH OR SURFACE JUNCTION BOX.
⊠	HEAT DETECTOR INITIATING DEVICE, STRUCTURE MOUNTED ABOVE SUSPENDED CEILING TO SURFACE JUNCTION BOX.
⊠	MANUAL PULL STATION INITIATING DEVICE, WALL MOUNTED AT +48" UON.
⊠	MOTOR OPERATED FIRE/SMOKE DAMPER FSD; NIC. SYMBOL DENOTES INTERFACE FOR POWER, CONTROL AND POSSIBLY MONITORING CONNECTIONS FROM FIRE ALARM SYSTEM. ALSO INCLUDES LOCAL POWER DISCONNECT MEANS. ES BY FSD IMPLIES END SWITCH CONNECTIONS FOR MONITORING BOTH 'OPEN' AND 'CLOSED' POSITIONS. ADJACENT NUMBER INDICATES QUANTITY OF ACTUATORS AND END SWITCH GROUPS REQUIRING CONNECTION PER FSD, IF MORE THAN 1.
⊠	SPRINKLER SYSTEM WATER FLOW SWITCH, NIC. SYMBOL DENOTES INTERFACE FOR MONITORING CONNECTION FROM FIRE ALARM SYSTEM.
⊠	SPRINKLER SYSTEM TAMPER SWITCH, NIC. SYMBOL DENOTES INTERFACE FOR MONITORING CONNECTION FROM FIRE ALARM SYSTEM.
⊠	SPRINKLER SYSTEM POST INDICATING VALVE PIV; NIC. SYMBOL DENOTES INTERFACE FOR MONITORING CONNECTION FROM FIRE ALARM SYSTEM. INCLUDE A REMOTE MOUNTED ADDRESSABLE MONITORING MODULE AT PIV.
⊠	REMOTE MOUNTED SINGLE INPUT, ADDRESSABLE, MONITORING MODULE FOR INITIATING CIRCUIT CONNECTION.
⊠	REMOTE MOUNTED DUAL INPUT, ADDRESSABLE, MONITORING MODULE FOR INITIATING CIRCUIT CONNECTION.
⊠	REMOTE MOUNTED PROGRAMMABLE CONTROL RELAY MODULE FOR ADDRESSABLE CONTROL.
⊠	DIFFERENTIAL PRESSURE SWITCH, NIC. SYMBOLS DENOTES INTERFACE FOR MONITORING CONNECTION FROM FIRE ALARM SYSTEM TO ANNUNCIATE FAN OPERATION. INCLUDE A REMOTE MOUNTED ADDRESSABLE MONITORING MODULE AT EACH LOCATION.
⊠	END-OF-LINE RESISTOR.
⊠	AIR PRESSURE SWITCH FOR PRE ACTION SPRINKLER SYSTEMS, NIC. SYMBOL DENOTES INTERFACE FOR MONITORING CONNECTION FROM FIRE ALARM SYSTEM. INCLUDE A REMOTE MOUNTED ADDRESSABLE MONITORING MODULE AT EACH LOCATION.
⊠	MAGNETIC TYPE DOOR HOLD OPEN/RELEASE DEVICE, WALL MOUNTED, NIC. SYMBOL DENOTES INTERFACE FOR POWER AND CONTROL CONNECTIONS FROM FIRE ALARM SYSTEM.
⊠	AUDIBLE NOTIFICATION APPLIANCE, WALL MOUNTED, 6" BELOW CEILING OR +80" AFF, WHICHEVER IS LOWER.
⊠	AUDIBLE/VISIBLE NOTIFICATION APPLIANCE, WALL MOUNTED, 6" BELOW CEILING OR +80" AFF, WHICHEVER IS LOWER. NUMBER ASSOCIATED WITH 'vd' REPRESENTS CANDELA RATING OF STROBE.
⊠	AUDIBLE NOTIFICATION APPLIANCE, CEILING MOUNTED IN FLUSH BACK BOX.
⊠	VISIBLE NOTIFICATION APPLIANCE, CEILING MOUNTED IN FLUSH BACK BOX. NUMBER ASSOCIATED WITH 'vd' REPRESENTS CANDELA RATING OF STROBE.
⊠	AUDIBLE/VISIBLE NOTIFICATION APPLIANCE, CEILING MOUNTED IN FLUSH BACK BOX. NUMBER ASSOCIATED WITH 'vd' REPRESENTS CANDELA RATING OF STROBE.
⊠	REMOTE 2-WAY COMMUNICATION STATION, MOUNTED +42" AFF.
⊠	REMOTE ANNUNCIATOR

WIRING DEVICES	
⊠	JUNCTION BOX, WALL MOUNTED, +18" UON
⊠	JUNCTION BOX, MOUNTED IN FLUSH FLOOR BOX.
⊠	JUNCTION BOX, MOUNTED FLUSH IN CEILING.
⊠	JUNCTION BOX, SURFACE OR PENDANT MOUNTED TO STRUCTURE IN ACCESSIBLE CEILING SPACE.
⊠	JUNCTION BOX, MOUNTED ON CONDUIT STANCHION FLOOR PENETRATION, +12" UON.
⊠	SINGLE-PLEX CONVENIENCE RECEPTACLE DEVICE, WALL MOUNTED, +18" UON.
⊠	DUPLEX CONVENIENCE RECEPTACLE DEVICE, WALL MOUNTED, +18" UON.
⊠	DOUBLE DUPLEX CONVENIENCE RECEPTACLE DEVICE, WALL MOUNTED, +18" UON.
⊠	DENOTES WALL MOUNTED OVER COUNTER, 6" ABOVE BACK SPLASH UON. BUT NO HIGHER THAN ADA REQUIREMENTS.
⊠	'G' DENOTES GROUND FAULT CURRENT INTERRUPTER (GFCI), 'A' DENOTES ARC FAULT CURRENT INTERRUPTER (AFCI).
⊠	DUPLEX CONVENIENCE RECEPTACLE DEVICE WITH INTEGRAL USB PORTS, WALL MOUNTED, +18" UON.
⊠	DUPLEX RECEPTACLE, WEATHER RESISTANT WITH GROUND FAULT CURRENT INTERRUPTER (GFCI) WITH WEATHERPROOF COVER, WALL MOUNTED, +18" UON.
⊠	SHADING DENOTES SPLIT WIRED DEVICE.
⊠	SHADING DENOTES DEVICE CONNECTED TO EMERGENCY POWER CIRCUIT.
⊠	SHADING DENOTES DEVICE CONTROLLED PER CA T24 130.5(d).
⊠	HORIZONTAL MOUNTED DUPLEX RECEPTACLE, +18" UON.
⊠	SHADING DENOTES SPECIALTY DEVICE, TYPE AS NOTED ON PLANS.
⊠	DUPLEX CONVENIENCE RECEPTACLE DEVICE, MOUNTED IN FLUSH FLOOR BOX.
⊠	DOUBLE DUPLEX CONVENIENCE RECEPTACLE DEVICE, MOUNTED IN FLUSH FLOOR BOX.
⊠	DUPLEX CONVENIENCE RECEPTACLE DEVICE, MOUNTED IN FIRE-RATED POKE-THRU FLOOR FITTING.
⊠	DOUBLE DUPLEX CONVENIENCE RECEPTACLE DEVICE, MOUNTED IN FIRE-RATED POKE-THRU FLOOR FITTING.
⊠	DUPLEX CONVENIENCE RECEPTACLE DEVICE, MOUNTED FLUSH IN CEILING.
⊠	DOUBLE DUPLEX CONVENIENCE RECEPTACLE DEVICE, MOUNTED FLUSH IN CEILING.
⊠	DUPLEX CONVENIENCE RECEPTACLE DEVICE, MOUNTED ON CONDUIT STANCHION FLOOR PENETRATION, +12" UON.
⊠	DUPLEX CONVENIENCE RECEPTACLE DEVICE, MOUNTED IN FLOOR MONUMENT.
⊠	COMBINATION POWER/TELECOMMUNICATION DEVICE, MOUNTED IN FLUSH FLOOR BOX. TYPE AS NOTED ON PLANS OR IN SPECIFICATIONS.
⊠	DUPLEX CONVENIENCE RECEPTACLE DEVICE, CORD OR REEL HUNG FROM STRUCTURE ABOVE. TYPE AS NOTED ON PLANS.
⊠	ELECTRIFIED FURNITURE PARTITION POWER FEED, WALL MOUNTED, +18" UON. CONSISTS OF 4 1 1/16" SQ. X 2 1/8" DEEP JUNCTION BOX, SINGLE GANG RING, AND STAINLESS STEEL COVER PLATE WITH KO TO ACCEPT FURNITURE WHIP.
⊠	ELECTRIFIED FURNITURE PARTITION COMBINATION POWER/TELECOMMUNICATION FEEDS, MOUNTED IN FLUSH FLOOR BOX WITH KO'S IN COVER TO ACCEPT FURNITURE WHIPS.
⊠	ELECTRIFIED FURNITURE PARTITION POWER FEED, MOUNTED IN FIRE-RATED POKE-THRU FLOOR FITTING WITH KO IN COVER TO ACCEPT FURNITURE WHIP.
⊠	POWER/TELECOMMUNICATION POLE, MOUNTED TO EXTEND FROM FLOOR TO CEILING. TYPE AS NOTED ON PLANS.
⊠	SINGLE-POLE, SINGLE-THROW SWITCH, WALL MOUNTED, +42" UON.
⊠	THREE-WAY SWITCH, WALL MOUNTED, +42" UON.
⊠	FOUR-WAY SWITCH, WALL MOUNTED, +42" UON.
⊠	KEY-OPERATED, SINGLE-POLE, SINGLE-THROW SWITCH, WALL MOUNTED, +42" UON.
⊠	PILOT LIGHT, SINGLE-POLE, SINGLE-THROW SWITCH, WALL MOUNTED, +42" UON.
⊠	MANUAL MOTOR STARTER SWITCH WITH THERMAL OVERLOAD ELEMENT, MOUNTED ADJACENT TO MOTOR.
⊠	MANUAL MOTOR STARTER/DISCONNECT SWITCH, MOUNTED ADJACENT TO MOTOR.
⊠	SWITCH FURNISHED UNDER ANOTHER DIVISION, BUT INSTALLED AND WIRED UNDER THIS DIVISION, WALL MOUNTED, +42" UON.
⊠	WALLBOX DIMMER SWITCH, +42" UON. SIZED PER CONNECTED LOAD ON PLANS AND FURNISHED FOR LAMP SOURCE SERVED. PROVIDED FOR DERATING WHEN INSTALLED GANGED LOCATIONS.
⊠	SINGLE-POLE, TIMER CONTROLLED SWITCH, WALL MOUNTED, +42" UON.
⊠	SINGLE-POLE, SINGLE-THROW, EXPLOSION PROOF SWITCH, WALL MOUNTED, +42" UON.
⊠	LINE VOLTAGE SINGLE RELAY VACANCY SENSOR, WALL MOUNTED, +42" UON.
⊠	SINGLE-POLE SWITCH WITH WEATHERPROOF COVER, WALL MOUNTED, +42" UON.
⊠	LINE-VOLTAGE MULTIPLE GANG SWITCHING STATION, WALL MOUNTED, 42" UON. REFER TO PLANS FOR DEVICE QUANTITIES AND TYPES.
⊠	LOW-VOLTAGE LIGHTING CONTROL SWITCHING STATION, WALL MOUNTED, +42" UON. REFER TO PLANS AND SCHEDULES FOR DEVICE QUANTITIES AND RELAYS CONTROLLED.
⊠	LIGHTING CONTROL OCCUPANCY SENSOR WITH DUAL LEVEL SWITCHING, WALL MOUNTED, +42" UON.
⊠	LIGHTING CONTROL OCCUPANCY SENSOR WITH SINGLE LEVEL SWITCHING, WALL MOUNTED, +42" UON.
⊠	LIGHTING CONTROL OCCUPANCY SENSOR, CEILING MOUNTED FOR AREA COVERAGE.
⊠	PRESET SCENE CONTROL LIGHTING STATION WITH DIMMING CAPABILITIES, WALL MOUNTED, +42" UON. REFER TO PLANS AND SCHEDULES FOR CONTROL.
⊠	REMOTE DIMMING OR SWITCHING MODULE, NUMBER OF ZONES AS INDICATED.
⊠	CONTROL STATION, WALL MOUNTED, +42" UON.
⊠	PHOTOELECTRIC CELL
⊠	DAYLIGHT SENSOR
⊠	PRIMARY DAYLIGHT ZONE

CONVENTIONS	
①	NUMBERED NOTE, APPLIES TO ALL DRAWINGS.
①	NUMBERED SHEET NOTE, APPLIES TO DRAWING CONTAINING NOTES ONLY.
①	OVERCURRENT PROTECTIVE DEVICE SPACE IDENTIFICATION TAG. REFERS TO LOCATION OF PROTECTIVE OR CONTROL DEVICE WITHIN SWITCHBOARDS, DISTRIBUTION BOARDS, MOTOR CONTROL CENTERS, ETC.
(NAME)	EQUIPMENT IDENTIFICATION TAG. ITEM FURNISHED AND INSTALLED UNDER ANOTHER SECTION AND WIRED UNDER THIS SECTION.
(P2)	CABLE AND/OR RACEWAY TAG, FUNCTION AS NOTED BELOW: P = POWER T = TELEPHONE C = COMMUNICATION
2004	FEEDER SIZE. REFER TO FEEDER SCHEDULE.
A-801	DETAIL REFERENCE: SHEET NUMBER DETAIL DESIGNATION
2-F3	FIXTURE IDENTIFICATION TAG: FIXTURE TYPE QUANTITY

POWER DISTRIBUTION	
⊠	SWITCHBOARD, DISTRIBUTION BOARD, SUBSTATION OR MOTOR CONTROL CENTER, FLOOR MOUNTED.
⊠	PANELBOARD, 277/480V, SURFACE MOUNTED ON WALL.
⊠	PANELBOARD, 277/480V, FLUSH MOUNTED IN WALL.
⊠	PANELBOARD, 120/208V, SURFACE MOUNTED ON WALL.
⊠	PANELBOARD, 120/208V, FLUSH MOUNTED IN WALL.
⊠	DRY-TYPE STEP-DOWN TRANSFORMER, FLOOR MOUNTED 3Ø, 480-120/208V, UON.
⊠	ELECTRIC MOTOR, NIC. MAKE POWER CONNECTIONS ONLY AS NOTED ON PLANS.
⊠	INDOOR EXHAUST FAN MOTOR, SINGLE PHASE. MAKE POWER CONNECTIONS TO INCLUDE JUNCTION BOX MOUNTED MANUAL MOTOR STARTER AND DISCONNECT ADJACENT TO FAN WITH 2 #12 CONDUCTORS PLUS GROUND IN 1/2" FLEXIBLE CONDUIT BETWEEN STARTER AND MOTOR.
⊠	INDOOR FAN POWERED VAV BOX MOTOR, SINGLE PHASE, MOUNTED FROM STRUCTURE ABOVE, NIC. MAKE POWER CONNECTIONS TO INCLUDE JUNCTION BOX MOUNTED MANUAL MOTOR STARTER AND DISCONNECT ADJACENT TO VAV BOX WITH 2 #12 CONDUCTORS PLUS GROUND IN 1/2" FLEXIBLE CONDUIT BETWEEN STARTER AND MOTOR.
⊠	PULLBOX OR HANDHOLE, SIZE AND TYPE AS NOTED ON PLANS.
⊠	SAFETY DISCONNECT SWITCH, 3 POLE, UON. ADJACENT NUMBER INDICATES FUSE SIZE WHEN APPLICABLE. LABELING CONVENTION AS FOLLOWS: A: 30A, NON-FUSED AF: 30A, FUSED B: 60A, NON-FUSED BF: 60A, FUSED C: 100A, NON-FUSED CF: 100A, FUSED D: 200A, NON-FUSED DF: 200A, FUSED E: 400A, NON-FUSED EF: 400A, FUSED F: 800A, NON-FUSED FF: 800A, FUSED G: 800A, NON-FUSED GF: 800A, FUSED
⊠	MAGNETIC MOTOR STARTER, ADJACENT NUMBER INDICATES NEMA SIZE OF STARTER.
⊠	COMBINATION MAGNETIC MOTOR STARTER/SAFETY DISCONNECT SWITCH, ADJACENT NUMBER INDICATES NEMA SIZE OF STARTER.
⊠	PACKAGE MOTOR CONTROLLER OR STARTER FURNISHED AND INSTALLED UNDER ANOTHER DIVISION WITH EQUIPMENT CONTROLLED. PROVIDE SINGLE-POINT POWER SERVICE CONNECTION UNDER THIS DIVISION AS NOTED ON PLANS.
⊠	VARIABLE FREQUENCY DRIVE FURNISHED AND INSTALLED UNDER ANOTHER DIVISION. PROVIDE POWER SERVICE CONNECTION UNDER THIS DIVISION AS NOTED ON PLANS.
⊠	VARIABLE FREQUENCY DRIVE WITH INTEGRAL DISCONNECT FURNISHED AND INSTALLED UNDER ANOTHER DIVISION. PROVIDE POWER SERVICE CONNECTION UNDER THIS DIVISION AS NOTED ON PLANS.
⊠	ELECTRONICALLY COMMUTATED MOTOR CONTROLLER FURNISHED AND INSTALLED UNDER ANOTHER DIVISION. PROVIDE POWER SERVICE CONNECTION UNDER THIS DIVISION AS NOTED ON PLANS.
⊠	ELECTRONICALLY COMMUTATED MOTOR CONTROLLER WITH INTEGRAL CIRCUIT BREAKER FURNISHED AND INSTALLED UNDER ANOTHER DIVISION. PROVIDE POWER SERVICE CONNECTION UNDER THIS DIVISION AS NOTED ON PLANS.
⊠	DRIVEN GROUND ROD.
⊠	DRIVING ROUND ROD IN GROUND WELL WITH COVER.
⊠	ELECTRICAL VEHICLE CHARGING STATION, WALL MOUNTED.

**Switchboard: MSB**

Location: ELECTRICAL / IT / MDF 121  
 Phases: 3  
 Wires: 4

Volts: 120/208 Wye  
 Wires: 4

A.I.C. Rating:  
 Mains Type:  
 Mains Rating:  
 MCB Rating:

CKT	(E) LA (E) LB	Circuit Description	Load	Remarks
1			65 kVA	
2			37 kVA	
3				
4				
5				
6				
7				
8				
9				
10				
11				
12				
13				
14				
15				
16				
17				
18				
19				
20				

Load Classification	Connected Load	Demand Factor	Estimated Demand	Panel Totals
Motor	31 kVA	107.34%	33 kVA	
Power	1 kVA	100.00%	1 kVA	
Lighting	4 kVA	125.00%	5 kVA	
Receptacle	66 kVA	57.59%	38 kVA	
				<b>Total Conn. Load: 102 kVA</b>
				<b>Total Est. Demand: 77 kVA</b>
				<b>Total Conn.: 283 A</b>
				<b>Total Est. Demand: 214 A</b>

Notes:

**COPPER FEEDER SCHEDULE**

FEEDER TAG	FEEDER DESCRIPTION	CONDUIT	PHASE/NEUTRAL	GROUND	REMARKS
403	30 AMP, 3 PHASE, 4 WIRE	1-0.75"	3 #8	1 #10	-
304K	30 AMP, 3 PHASE, 4 WIRE	1-0.75"	3 #10, 1 #6 NEU.	1 #10	①
304	30 AMP, 3 PHASE, 4 WIRE	1-0.75"	4 #10	1 #10	-
303	30 AMP, 3 PHASE, 3 WIRE	1-0.75"	3 #10	1 #10	-
204	20 AMP, 3 PHASE, 4 WIRE	1-0.75"	4 #12	1 #12	-
203	20 AMP, 3 PHASE, 3 WIRE	1-0.75"	3 #12	1 #12	-
154	15 AMP, 3 PHASE, 4 WIRE	1-0.75"	4 #12	1 #12	-
153	15 AMP, 3 PHASE, 3 WIRE	1-0.75"	3 #12	1 #12	-

- FEEDER SCHEDULE GENERAL NOTES**
- CONDUCTORS AND CONDUITS SHOWN IN THIS SCHEDULE ARE BASED ON COPPER CONDUCTORS WITH THHN/THWN INSULATION.
  - FEEDERS CONSISTING OF MULTIPLE SETS OF CONDUITORS AND CONDUITS ARE TO BE PROVIDED WITH THE INDICATED SIZE GROUND CONDUCTOR IN EACH CONDUIT.
- FEEDER SCHEDULE REMARK**
- OVERSIZED NEUTRAL FOR SERVICE FROM K-13 RATED TRANSFORMERS.

**LIGHTING FIXTURE SCHEDULE**

TYPE	MANUFACTURER & CATALOG NUMBER	LAMP INFORMATION	BALLAST/DRIVER QTY/TYP	WATTAGE	VOLTAGE	DESCRIPTION
F1	HE WILLIAMS LT-2-4-L52-835-AF-DIM-UNV OR APPROVED EQUAL	LED ~5200 LUMEN 3500K 80+ CRI MIN 50,000 HR L70	0-10V DIMMING LED DRIVER	37 W	120V	2'X4' ARCHITECTURAL HIGH EFFICIENCY RECESSED LED TROFFER, STEEL HOUSING WITH WHITE POWDER COAT FINISH AND HIGHLY EFFICIENT SATIN WHITE LENS. MIN. 5 YEAR WARRANTY.
F1A	HE WILLIAMS LT-2-4-L64-835-AF-DIM-UNV OR APPROVED EQUAL	LED ~6400 LUMEN 3500K 80+ CRI MIN 50,000 HR L70	0-10V DIMMING LED DRIVER	49 W	120V	SAME AS F1, BUT HIGHER LUMEN OUTPUT.
F1B	HE WILLIAMS LT-2-4-L40-835-AF-DIM-UNV OR APPROVED EQUAL	LED ~4000 LUMEN 3500K 80+ CRI MIN 50,000 HR L70	0-10V DIMMING LED DRIVER	32 W	120V	SAME AS F1, BUT LOWER LUMEN OUTPUT.
F1C	HE WILLIAMS LT-2-4-L52-835-AF-DFK-2448W-DIM-UNV OR APPROVED EQUAL	LED ~5200 LUMEN 3500K 80+ CRI MIN 50,000 HR L70	0-10V DIMMING LED DRIVER	37 W	120V	SAME AS F1, BUT WITH DRYWALL RECESSED MOUNTING KIT.
F2	HE WILLIAMS SLF-4-L52-835-HIA-120V OR APPROVED EQUAL	LED 5200 LUMEN PER/FT 3500K 80+ CRI MIN 50,000 HR L70	0-10V DIMMING LED DRIVER	58 W	120V	WALL MOUNTED LED FIXTURE.
F2A	HE WILLIAMS SLF-4-L52-835-HIA-EM/10W-120V OR APPROVED EQUAL	LED 5200 LUMEN PER/FT 3500K 80+ CRI MIN 50,000 HR L70	0-10V DIMMING LED DRIVER	58 W	120V	SAME AS F2, BUT WITH 10-WATT EM LED DRIVER.
F3	FINELITE S16-LED-ID-DCO-8'-2E-V-8-3500K-SC-12 0V-FA-FE-C1 OR APPROVED EQUAL	LED 9.3W / 1' 1181 LUMENS / 1' 3500K 80+ CRI MIN 100,000 HR L90	0-10V DIMMING LED DRIVER	75 W	120V	8' LONG LINEAR SUSPENDED LED LUMINAIRE, INDIRECT/DIRECT DISTRIBUTION, WITH DIE-FORMED STEEL HOUSING WITH WHITE POWDER COAT FINISH, AND DIFFUSE ACRYLIC LENS. PROVIDE WITH ENDCAPS, CANOPY KITS, AND POWER/NON-POWER FEEDS AS REQUIRED FOR COMPLETE INSTALLATION. INSTALL AT +8'-0" A.F.F. TO BOTTOM OF FIXTURE U.O.N. DLC COMPLIANT, 10 YEAR WARRANTY.
F4	PHILIPS FLUXSTREAM INDUSTRIAL FS1-4-40L-835-120-DIM OR APPROVED EQUAL	LED 4000 LUMEN 3500K 80+ CRI MIN 100,000 HR L70	0-10V DIMMING LED DRIVER	31 W	120V	8' LONG, SUSPENDED INDUSTRIAL PENDANT.
F5	HE WILLIAMS 1SF UNDER CABINET 1SF-4-L24-AF12125-120 OR APPROVED EQUAL	LED 2400 LUMEN 3500K 80+ CRI MIN 50,000 HR L85	0-10V DIMMING LED DRIVER	29 W	120V	SURFACE MOUNTED UNDER CABINET LED LIGHT FIXTURE.
F6	PHILIPS SLIM SURFACE S6S835K10AL-Z10U OR APPROVED EQUAL	LED 1000 LUMEN 3500K 80+ CRI MIN 50,000 HR L70	0-10V DIMMING LED DRIVER	14 W	120V	NOMINAL 6" SQUARE SLIM SURFACE MOUNTED LED.
SF1	WAC "ENDURANCE FIN" WP-LED127-30-GH OR APPROVED EQUAL	27W LED 2073 LUMEN 85 CRI MIN 100,000 HR	0-10V DIMMING LED DRIVER	27 W	120V	EXTERIOR LED WALL SCENCE, WITH DIE-CAST ALUMINUM HOUSING WITH POWDER COAT FINISH, "GRAPHITE" COLOR TO BE VERIFY BY ARCH. FORWARD THROW ILLUMINATION, WITH UNIVERSAL MOUNTING BRACKET FOR INSTALLATION OVER 4" JUNCTION BOX. IP66 WET LOCATION LISTED.
X1	HE WILLIAMS EXIT/EM/LED-G-WHT-D OR APPROVED EQUAL	LED		3 W	120V	EXIT SIGN WITH EM BATTERY BACK UP, ADJUSTABLE DIRECTION INDICATORS AND FIELD AND DOUBLE FACE CONVERSION READY.
X2	HE WILLIAMS EXIT/EM/LED-G-WHT-DRHL-D OR APPROVED EQUAL	LED		5 W	120V	EXIT SIGN WITH EMERGENCY LED LAMP HEAD AND EM BATTERY BACK UP.

Branch Panel (E) LA		Served From MSB		Phases 3		A.I.C. Rating: 10 KAIC		Bus Rating 225 A			
MOUNTING: RECESSED		Volts: 120/208 Wye		Wires 4		Main Type: MLO		Main Rating: 225 A			
LOAD SERVED	Amp	#	A (kVA)	B (kVA)	C (kVA)	#	P	Amp	LOAD SERVED		
Rec Room 109, 108, 106	20 A	1	1.08	2.16				2	1	20 A	Partition Feed Open Office 118
Rec Room 107, 108	20 A	1	3		1.08	2.16		4	1	20 A	Partition Feed Open Office 118
Rec Room 107, 102	20 A	1	5			0.90	4.32	6	1	20 A	Partition Feed Open Office 118
Rec Reception 102	20 A	1	7	0.36	4.32			8	1	20 A	Partition Feed Open Office 118
Rec Room 103, 100, 123	20 A	1	9		1.08	4.32		10	1	20 A	Partition Feed Open Office 118
Self Check-in Kiosk Waiting 103	20 A	1	11			0.30	4.32	12	1	20 A	Partition Feed Open Office 118
Rec Interview Booths 104	20 A	1	13	1.08	2.16			14	1	20 A	Partition Feed Open Office 118
Rec Room 104, 119	20 A	1	15		1.08	2.16		16	1	20 A	Partition Feed Open Office 118
Printer/Copier	20 A	1	17			0.80	4.32	18	1	20 A	Partition Feed Open Office 118
Rec Large Meeting Room 123	20 A	1	19	1.08	4.32			20	1	20 A	Partition Feed Open Office 118
Receptacle Open Office 118	20 A	1	21		2.16	4.32		22	1	20 A	Partition Feed Open Office 118
Receptacle Open Office 118	20 A	1	23			2.16	4.32	24	1	20 A	Partition Feed Open Office 118
SPARE	20 A	1	25	0.00	2.16			26	1	20 A	Partition Feed Open Office 118
(E) Exterior Lighting	20 A	1	27			0.28	2.16	28	1	20 A	Partition Feed Open Office 118
SPARE	20 A	1	29			0.00	1.08	30	1	20 A	Rec Open Office 118
SPARE	20 A	1	31	0.00	0.72			32	1	20 A	Rec Room 117, 116, 115, 113
SPARE	20 A	1	33		0.00	0.18		34	1	20 A	Rec Counter Break Room 117
SPARE	20 A	1	35			0.00	0.18	36	1	20 A	Garbage Disp. Break Rm 117
SPARE	20 A	1	37	0.00	0.18			38	1	20 A	Rec Counter Break Room 117
SPARE	20 A	1	39		0.00	0.80		40	1	20 A	Refrigerator Break Room 117
SPARE	20 A	1	41			0.00	1.08	42	1	20 A	Rec Room 114, 112, 110, 111, ...
<b>Total Load:</b>			19.62 kVA	21.78	23.76						
<b>Total:</b>			164 A	184 A	201 A						

Branch Panel (E) LB		Served From MSB		Phases 3		A.I.C. Rating: 10 KAIC		Bus Rating 225 A			
MOUNTING: RECESSED		Volts: 120/208 Wye		Wires 4		Main Type: MLO		Main Rating: 225 A			
LOAD SERVED	Amp	#	A (kVA)	B (kVA)	C (kVA)	#	P	Amp	LOAD SERVED		
Rec Data Rack Electrical / IT / ...	20 A	1	0.18	2.31				2	1	20 A	Lig 104, 115, 116, 119, 120.
Rec Data Rack Electrical / IT / ...	20 A	1	3		0.18	1.24		4	1	20 A	Lig 100, 103, 102, 106, 107, 10.
Rec Data Rack Electrical / IT / ...	20 A	1	5			0.18	0.18	6	1	20 A	Rec AC-1
Rec Access Control Panel	20 A	1	7	0.36	0.00			8	1	20 A	SPARE
Rec Electrical / IT / Mdf 121	20 A	1	9		0.36	0.00		10	1	20 A	SPARE
Rec Electrical / IT / Mdf 121	20 A	1	11			0.18	0.00	12	1	20 A	SPARE
Rec Electrical / IT / Mdf 121	20 A	1	13	0.18	0.00			14	1	20 A	SPARE
Water Heater Janitor 110	20 A	1	15		0.50	0.00		16	1	20 A	SPARE
AC-1EXH	20 A	1	17			0.37	0.05	18	2	20 A	SCU-1
			19	0.37	0.05			20			
			21		0.37	0.80		22	1	20 A	VAV Large Meeting Room 123
AC-2EXH	20 A	3	23			0.37	0.70	24	1	20 A	EF-1
			25	0.37	3.00			26	3	40 A	AC-1
			27			0.37	3.00	28			
AC-3EXH	20 A	3	29			0.37	3.00	30			
			31	0.37	3.00			32	3	40 A	AC-2
			33			0.37	3.00	34			
FACP	20 A	1	35			0.40	3.00	36			
LCP	20 A	1	37	0.40	2.42			38	3	30 A	AC-3
SPARE	20 A	1	39			0.00	2.42	40			
SPARE	20 A	1	41			0.00	2.42	42			
<b>Total Load:</b>			12.99 kVA	12.59	11.20						
<b>Total:</b>			110 A	107 A	93 A						

Notes: REUSE EXISTING BREAKERS AND ADD AS REQUIRED TO MEET PANEL SCHEDULE NEEDS.

**PROJECT GENERAL NOTES**

- EXISTING CONDITIONS
  - THE EXISTING CONDITIONS INDICATED IN THIS DRAWING SET WERE DEVELOPED FROM VARIOUS SOURCES WHICH WERE NOT ALL FIELD VERIFIED AND NOT ALL CONDITIONS ARE SHOWN. LOCATIONS, ROUTING, ELEVATIONS, SIZES, ETC. ARE SHOWN SCHEMATICALLY. CONTRACTOR SHALL VERIFY EXISTING CONDITIONS PRIOR TO CONSTRUCTION.
  - DRAWINGS INDICATE GENERAL ARRANGEMENT OF SYSTEMS AND WORK. FOLLOW DRAWINGS IN LAYING OUT WORK AND CHECK DRAWINGS OF OTHER TRADES TO VERIFY SPACE CONDITIONS. FINAL LOCATIONS SHALL BE ADJUSTED TO MEET FIELD CONDITIONS.
- DEMOS & GENERAL CONDITIONS
  - CONTRACTOR SHALL DISCONNECT AND REMOVE ALL DEMOLISHED DEVICES AND FIXTURES AS SHOWN ON DEMOLITION PLAN. TURN OVER TO OWNER EXISTING DEVICES AND FIXTURES THAT ARE NOT REUSED. PROPERLY DISCARD IF THE OWNER DOES NOT WANT.
  - NEW EXISTING DEVICES WHOSE CIRCUITS HAVE BEEN INTERRUPTED BY DEMOLITION BY PROVIDING NEW CONNECTIONS TO ANOTHER EXISTING DEVICE OR PANEL. VERIFY CIRCUIT LOADING ON EXISTING CIRCUIT.
  - MOUNTING HEIGHTS SHOWN ARE FROM FINISHED FLOOR TO THE CENTERLINE OF DEVICES. COORDINATE WITH ARCHITECTURAL DRAWINGS.
- EQUIPMENT, CONDUIT, WIRE, BOXES & DEVICES
  - PROVIDE INDIVIDUAL GFCI RECEPTACLES AT EACH LOCATION SHOWN. DO NOT USE FEED-THRU GFCI TYPE RECEPTACLES. LOCATE RECEPTACLE AT END OF A BRANCH CIRCUIT WIRE.
  - PER SECTION 41.0 (B)(2)(A), COMPLETE POWER DISTRIBUTION SYSTEM IS EXISTING. THEREFORE PLUG LOAD CONTROLS ARE EXEMPT.
  - CONDUIT SIZE SHALL BE 1.0" MINIMUM, U.O.N.
  - ALL CONDUCTORS ON THIS PROJECT SHALL BE COPPER.
  - FEEDER AND BRANCH CIRCUIT HOMERUNS SHALL BE INSTALLED IN CONDUIT. MC TYPE CABLE SHALL NOT BE USED FOR ANY HOMERUNS ON THIS PROJECT.
  - INSTALL AND CONNECT A CODE SIZED INSULATED OR BARE COPPER GROUNDING CONDUCTOR IN ALL BRANCH CIRCUITS AND FEEDERS.
  - ALL DEVICES SHALL HAVE TYPE ON TAPE LABELS INDICATING THE PANELBOARD AND CIRCUIT SERVING EACH DEVICE. TYPICAL OF ALL DEVICES INCLUDED ON THIS PROJECT.
  - PROVIDE INSULATING BUSHINGS OR INSULATED THROAT ON THE ENDS OF ALL EMPTY CONDUIT SLEEVES AND INSTALL A POLYETHYLENE PULLING ROPE.
  - WHERE CIRCUITS ARE SHOWN ON THE DRAWINGS WITH HOMERUNS THAT SHARE NEUTRAL CONDUCTORS THE CONTRACTOR SHALL PROVIDE HANDLE TIES BETWEEN ALL BRANCH CIRCUIT BREAKER LOADS WHICH SHARE A NEUTRAL.
  - SURFACE INSTALLED CONDUIT WHERE APPROVED, AND INSTALLED, SHALL BE PAINTED TO MATCH THE ARCHITECTURAL FINISHES IN THAT AREA.
  - PROVIDE DEDICATED CONDUIT/PATHWAYS FOR ALL 0-10V LIGHTING CONTROL SIGNALS SEPARATE FROM ALL LINE VOLTAGE RACEWAY.
  - ALL OUTDOOR ELECTRICAL EQUIPMENT SHALL BE WEATHER-PROTECTED AND LISTED FOR EXTERIOR USE.
  - PROVIDE TYPE WRITTEN PANEL SCHEDULES UPDATED TO INCLUDE ALL FIELD MODIFICATIONS AND SCOPE ITEMS ASSOCIATED WITH THIS PROJECT.
  - PROVIDE ENGRAVED NAMEPLATES FOR ELECTRICAL BOARDS, DISCONNECTS, AND SWITCHGEAR.
- FIRE ALARM & FIRE RATED ITEMS
  - ALL CIRCUIT BREAKERS SERVING THE FIRE ALARM CONTROL PANEL AND FIRE ALARM SYSTEM COMPONENTS SHALL HAVE LOCKABLE HANDLES, AND PAINTED RED FOR EASY IDENTIFICATION.
  - ALL CONDUIT, OUTLET BOXES, AND RACEWAY PENETRATIONS THROUGH FIRE RATED WALLS OR FLOOR ASSEMBLIES SHALL BE A LISTED ASSEMBLY THAT PROTECTS THE RATED ASSEMBLY. INCLUDE FIRE RATED DEVICE BOX ASSEMBLIES WHEN REQUIRED. SEE ARCHITECTURAL DRAWINGS FOR LOCATIONS OF ALL RATED WALLS AND FLOORS AS APPLICABLE.
  - PROVIDE A REMOTE TEST/RESET STATION FOR EACH SMOKE DUCT DETECTOR NOT ACCESSIBLE FROM THE ROOF OR CEILING SPACE. LOCATE STATION ON THE WALLS OR LOW CEILING BELOW THE DUCT DETECTOR AND LABEL WITH THE HVAC UNITS IDENTIFICATION NUMBER. INCLUDE AN ADDRESSABLE FA CONTROL MODULE FOR MONITORING.
- CODE REQUIREMENTS & ELEC. CLEARANCES
  - ALL ELECTRICAL WORK SHALL COMPLY WITH THE LATEST EDITION OF THE CALIFORNIA ELECTRICAL CODE (CEC).
  - CONTRACTOR IS RESPONSIBLE TO SUBMIT REVISED LAYOUT OF EQUIPMENT IN ELECTRICAL SPACES FOR WRITTEN APPROVAL BY ENGINEER IF PROPOSED INSTALLATION LOCATION DIFFERS FROM CONSTRUCTION DOCUMENTS. SUBMISSION MUST BE APPROVED PRIOR TO RELEASE OF ORDER FOR EQUIPMENT AND PRIOR TO INSTALLATION.
  - REQUIRED ELECTRICAL EQUIPMENT WORKING SPACE DEPTH SHALL NOT BE LESS THAN THAT INDICATED IN CEC TABLE 110.26. THE WIDTH OF THE WORKING SPACE IN FRONT OF THE ELECTRICAL EQUIPMENT SHALL BE THE WIDTH OF THE EQUIPMENT OR 30", WHICHEVER IS GREATER. THIS REQUIREMENT ALSO APPLIES TO DISCONNECT SWITCHES.
  - ALL ELECTRICAL MATERIALS AND EQUIPMENT SHALL BE LISTED BY UNDERWRITERS LABORATORIES AND BEAR THEIR LABEL OR ETL.
  - PROVIDE ALL NEW BOARDS, BREAKERS, SWITCHES, ETC. IN ACCORDANCE WITH THE CONTRACTOR PREPARED POWER SYSTEM STUDY. NO EQUIPMENT SHALL BE PURCHASED, INSTALLED, AND/OR RELEASED PRIOR TO ENGINEER REVIEW AND APPROVAL OF THE POWER SYSTEM STUDY.
  - CONTRACTOR SHALL PROVIDE ARC FLASH LABELS FOR ALL ELECTRICAL EQUIPMENT WITHIN THE SCOPE OF THIS PROJECT. THESE LABELS SHALL BE GENERATED BY THE CONTRACTOR FROM THE POWER SYSTEM STUDY AND SUBMITTED WITH THE POWER SYSTEM STUDY SUBMITTAL FOR ENGINEER REVIEW AND APPROVAL. THIS INCLUDES ALL FIELD MARKING OF KAIC VALUES ON EXISTING OR NEW BOARDS PER THE CEC.

**PROJECT GENERAL NOTES**

- WIRING SPACE IN PANELBOARDS, DISTRIBUTION PANELS AND SWITCHBOARDS SHALL BE DEDICATED TO CONDUCTORS TERMINATED IN THAT ENCLOSURE. PANELBOARDS, DISTRIBUTION PANELS AND SWITCHBOARDS SHALL NOT BE USED AS PULL AND/OR SPICE BOXES FOR CONDUCTORS THAT TERMINATE IN OTHER ENCLOSURES. DO NOT SPICE CONDUCTORS IN EQUIPMENT.
- NEW CIRCUIT BREAKERS INSTALLED IN EXISTING EQUIPMENT SHALL BE PROVIDED TO MATCH THE KAIC RATINGS AND THE MANUFACTURER OF THE EXISTING.
- PROVIDE CLEAR SIGNAGE ON ALL ELECTRICAL EQUIPMENT PER CEC TO INDICATE THE ARC FLASH HAZARD WARNING, AND THE MAXIMUM AVAILABLE FAULT CURRENT. WHEN MODIFICATIONS OCCUR THAT AFFECT THE MAXIMUM FAULT CURRENT THE CONTRACTOR SHALL RECALCULATE AS NECESSARY AND REMARK THE EQUIPMENT.
- COORDINATION
  - REFER TO MECHANICAL & PLUMBING DRAWINGS FOR EXACT LOCATIONS OF EQUIPMENT. PROVIDE ALL LINE VOLTAGE AND LOW VOLTAGE WIRING, CONTROL WIRING, INTERLOCK CABLING, AND CONDUIT REQUIRED.
  - A DISCONNECTING MEANS AT ALL MOTORS, WHETHER INDICATED ON THE PLANS OR NOT.
  - FUSES IN DISCONNECTS FOR MECHANICAL EQUIPMENT AS COORDINATED WITH THE UNITS NAMEPLATE AND MANUFACTURERS INSTALLATION INSTRUCTIONS. FUSES SHALL BE CURRENT LIMITING TYPE.
  - PROVIDE A GFCI TYPE DEVICE WITH WEATHER PROOF WHILE IN USE COVER WITHIN 2' OF ALL EXTERIOR HVAC/PLUMBING EQUIPMENT.
  - WORK PERFORMED FROM THESE DRAWINGS SHALL ALSO COMPLY WITH THE PROJECT SPECIFICATIONS, IN THE EVENT THAT THERE IS A CONFLICT BETWEEN THE DRAWINGS AND SPECIFICATIONS, THE MORE STRINGENT REQUIREMENT SHALL TAKE PRECEDENT.
  - CONTRACTOR SHALL CONFIRM THAT ALL LIGHTING FIXTURES SPECIFIED, AND THE CEILING TYPES, FIXTURE TRIMS, AND FRAMES ARE ALL COMPATIBLE PRIOR TO THE CONTRACTOR LIGHTING FIXTURE SUBMITTAL.
- MISC.
  - IN ADDITION TO THE WORK SHOWN ON THESE PLANS, THE CONTRACTOR SHALL PROVIDE ALL CONDUIT, BACK BOXES, AND RACEWAY REQUIRED FOR THE FIRE ALARM SYSTEM, SECURITY SYSTEM, AV SYSTEM, AND TELECOM SYSTEM ON THIS PROJECT. PLEASE REFER THE LOW VOLTAGE SYSTEM DRAWINGS AND SPECIFICATIONS FOR EXACT LOCATIONS, ADDITIONAL INFORMATION, AND COMPLETE SCOPE OF WORK.
  - PROVIDE ALL LABOR, EXIT SIGNS, AND MATERIAL COSTS FOR THE COMPLETE INSTALLATION OF LED LIT EXIT SIGNS. THE INSTALLATION LOCATIONS ARE TO BE DETERMINED DURING THE FINAL PROJECT INSPECTION WITH THE AHI. TURN OVER ANY UNUSED EXIT SIGNS TO THE OWNER'S ATTIC STOCK FOR FUTURE USE.
  - PROVIDE SPECIALLY COLOR DEVICES AND COVERPLATES FOR ALL GENERATOR POWERED DEVICES. COORDINATE THE COLOR WITH SPECIFICATIONS AND OWNERS REPRESENTATIVE UNO.
  - PER CEC ARTICLE 517 PROVIDE SEPARATE ELECTRICAL RACEWAYS.
  - CONTRACTOR SHALL PREPARE RED LINED AS-BUILT DOCUMENTS REPRESENTING THE ACTUAL FIELD ROUTINGS AND INSTALLATION LOCATIONS FOR ALL ITEMS ON THIS PROJECT.
  - SURFACE INSTALLED CONDUIT WHERE APPROVED, AND INSTALLED, SHALL BE PAINTED TO MATCH THE ARCHITECTURAL FINISHES IN THAT AREA.
  - CONDUIT ROUTING (WHERE SHOWN) IS ESSENTIALLY DIAGRAMMATIC. CONTRACTOR SHALL LAYOUT RUNS TO SUIT FIELD CONDITIONS AND THE COORDINATION REQUIREMENTS OF OTHER TRADES.
  - DRAWINGS INDICATE JUNCTION BOXES WITH HOMERUNS ON THE PLANS, BUT THE CONTRACTOR SHALL PROVIDE ALL INTERMEDIATE RACEWAY WORK AND CONDUCTORS/CABLING BETWEEN THE DEVICES, FIXTURES, AND JUNCTION BOXES AS COORDINATED WITH ALL FIELD CONDITIONS AND TRADES.
  - CONTRACTOR SHALL PREPARE A DETAILED CONDUIT ROUTING DIAGRAM, INCLUDING MAJOR CONDUIT RUNS FROM PANELS OF ORIGIN OUT TO ALL BRANCH CIRCUIT CONNECTIONS (DOWN TO THE DEVICE LEVEL), LIGHT FIXTURE CONNECTIONS, CONTROLS, ETC. AS A SHOP DRAWING FOR REVIEW AND APPROVAL BY THE ENGINEER AND OWNER. THIS SHALL BE SUBMITTED, REVIEWED, AND APPROVED PRIOR TO ANY ROUGH-IN WORK IN THE FIELD.
  - THE DRAWINGS DO NOT FULLY REPRESENT THE ENTIRE INSTALLATION FOR THE SYSTEMS INDICATED BELOW. THE CONTRACTOR IS REQUIRED TO COMPLETE THE DESIGN FOR THESE SYSTEMS AS SPECIFIED HEREIN AND AS INDICATED ON THE DRAWINGS. CAD OR REVIT SHOP DRAWINGS SHALL BE SUBMITTED FOR REVIEW PRIOR TO INSTALLATION.
  - LIGHTING AND DEVICE BRANCH CIRCUITING- DRAWINGS INDICATE ABOVE CEILING POWER JUNCTION BOXES, HOMERUNS, CIRCUITING AT TEACH JUNCTION BOX, AND LOCAL MEANS OF CONTROL. CORRESPONDING CIRCUIT NUMBERS ARE INDICATED ADJACENT TO LIGHTING FIXTURES AND RECEPTACLES. CONNECTIONS TO ALL FIXTURES AND DEVICES ARE NOT INDICATED ON THE PLANS BUT ARE REQUIRED.
  - FIRE ALARM SYSTEM- DRAWINGS INDICATE THE LOCATION OF ALL CONTROL PANEL COMPONENTS, INITIATING DEVICES, ANNUNCIATING DEVICES, COMMUNICATIONS SYSTEM COMPONENTS, AUXILIARY EQUIPMENT CONTROL, AND CONDUIT BETWEEN BUILDINGS, CONDUITS WIRE AND CABLING BETWEEN ALL SYSTEM EQUIPMENT, DEVICES, ETC. ARE NOT INDICATED AND SHALL BE COMPLETED BY THE FIRE ALARM SYSTEM SHOP DRAWING DESIGNER.
  - SEC



ARCH | NEXUS

Architectural NEXUS, Inc.  
930 R Street  
Sacramento, California 95811  
T 916.443.5911  
http://www.archnexus.com

Original drawings remain the property of the Architect and as such the Architect retains total ownership and control. The design represented by these drawings is sold to the client for a one time use, unless otherwise agreed upon in writing by the Architect. © Architectural Nexus, Inc. 2014

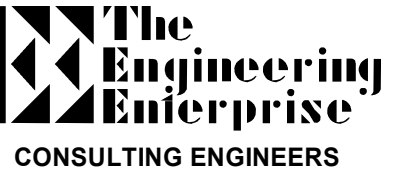

1125 HIGH STREET  
AUBURN, CA 95603  
(530) 886-8556

EL DORADO COUNTY  
EDC HHS TENANT IMPROVEMENT  
3368 SANDY WAY  
SOUTH LAKE TAHOE, CA 96150

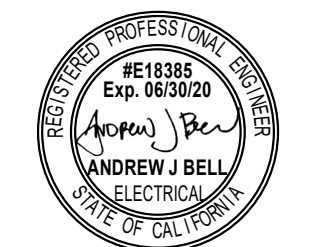

# Date Revision

CONSTRUCTION DOCUMENTS

NEXUS PROJ. #: 18117  
CHECKED BY: Checker  
DRAWN BY: Author  
DATE: 01/02/2019

LOW VOLTAGE INSTRUCTIONS & SPECS

E002

18-1912 Revised B 11/01/2019  
BOS Rcvd 1-24-19

3368 Sandy Way County-purchased and installed equipment

- MDF Patch Cables
(QTY 65) 40 6H460-04W Leviton eXtreme Cat 6 SlimLine Boot Patch Cord, 4 ft, White, or equivalent
(QTY 5) 6D460-05Y Leviton eXtreme Cat 6 SlimLine Boot Patch Cord, 5 ft, Yellow, or equivalent
(QTY 15) 6D460-05W Leviton eXtreme Cat 6 SlimLine Boot Patch Cord, 5 ft, White, or equivalent
(QTY 1) 6D460-15R Leviton eXtreme Cat 6 SlimLine Boot Patch Cord, 5 ft, Red, or equivalent

- Workstation Patch Cables
(QTY 20) - 6D460-10W Leviton eXtreme Cat 6 SlimLine Boot Patch Cord, 10 ft, White, or equivalent
(QTY 20) - 6D460-15W Leviton eXtreme Cat 6 SlimLine Boot Patch Cord, 15 ft, White, or equivalent
(QTY 15) - 6D460-20W Leviton eXtreme Cat 6 SlimLine Boot Patch Cord, 20 ft, White, or equivalent
(QTY 15) - 6D460-25W Leviton eXtreme Cat 6 SlimLine Boot Patch Cord, 25 ft, White, or equivalent
(QTY 6) - 492RU-HFO Leviton Cable Management, 2RU, 3"x3" Front Only

- Battery backup data switches
(QTY 1) - SMX2200RMV2U APC Smart-UPS X 2000VA Rack LCD 100-127V
(QTY 1) - SMX120BP Battery Unit

- Battery backup video system / camera switches
(QTY 1) - SMX2200RMV2U APC Smart-UPS X 2200VA Rack LCD 100-127V

- Wireless AP
(QTY 3) - IAP-315-US - Aruba Instant IAP-315 Wireless Access Point
(QTY 3) - SNI-IAP-315-US - NBD Support for IAP-315-US, 1 year
Cisco Switches
(QTY 2) - C9300-48P-A Cisco Catalyst 9300 48-Port PoE+ Ethernet Switch, Network Advantage License
(QTY 2) C9300-NM-4G= Cisco Catalyst 9300 4X1GE Network Module Spare
(QTY 1) C9300-24P-A Cisco Catalyst 9300 24-Port PoE+ Ethernet Switch Network Advantage License
(QTY 2) CON-3SNT-C93004PA Cisco Smartnet Support, 3YR for C9300-48P-A
(QTY 1) CON-3SNT-C93002PA Cisco Smartnet Support, 3YR for C9300-24P-A

- results of all cables tests, as-built drawing of all cable runs complete with jack numbers electronic delivery accepted.
If not readily visible, install UFER-compliant ground post in MDF.
Install main ground bar on 1/2 fire-rated backboard in MDF, run #6 ground wire and attach to visible UFER ground in MDF.
Ground bar installed on the top of all racks, attached #6 Ground wire to rack grounding bar and run # 6 wire to main ground bar installed on MDF Backboard.
QTY 3 - 20-AMP Dedicated Electrical Outlet , 1 per rack

- Equipment Specifications
(QTY - 2) 2-post rack - SB959084XUB B-Line Standard Equipment Rack, 19", flat black, 84.007H, 3" Channel, tapped rails or equivalent
(QTY - 1) 4-post rack - SB837084CFB B-Line Adjustable depth equipment rack, 84 H to 30 to 36 in. D, tapped rails or equivalent
Ladder rack - SB13AL12FB Eaton B-Line Redi-Rail Runway 1 1/2"
Cable Tray - ASTM4810 Eaton B-Line Flextray cable raceway, w/ Solid Bottom Inserts, and appropriate mounting and connecting accessories, Black powder coat finish
(QTY - 3) Rack Ground bar - SB97903 B-Line Universal 19" ground bar, or equivalent
(QTY - 1) Main Ground bar - SBTMB12 B-Line Telecommunications Ground bar, or equivalent
Ground wire - #6
Cable - 10032455 or 11074694 Berk-Tek Lanmark 1000 Cal 6e CMR, Color Black
(QTY - 276) Connectors - 61116-RV6 Leviton eXtreme Cat 6A UTP Connector, color yellow
Flush mount wall plates
- 43060-1S2 Leviton Stainless Steel QuickPort Wallplate, Single Gang, 2-Port
- 43060-1S3 Stainless Steel QuickPort Wallplate, Single Gang, 3-Port
Surface-mount box -
- 41089-2WP Surface-Mount QuickPort Box, Plenum Rated, 2-Port, White
Modular Furniture Box -
- Maxon
(QTY 3) - Patch Panel - 49255-H48 Leviton QuickPort Patch Panel, 48 port, 1RU. Cable management bar included.
(QTY 1) - Patch Panel - 49255-H24 Leviton QuickPort Patch Panel, 24 port, 1RU. Cable management bar included.
Wire management
- (QTY 7) - 492RU-HFR Leviton Cable Management, 2RU, 3"x3" Front and 2"x4" Rear
- (QTY 12) - 4940L-VFR Leviton Cable Management, 5" channel x 40" Long, (-

3368 Sandy Way LT. / Low Voltage Instructions and Specifications

Sub-Contractor Provide and Install

- If not already installed, 3/4" fire-rated backboard in MDF. See diagram for location and dimensions
7FTx19W, 45U, relay racks in MDF room using Strongtie or Hilli Anchors
7FTx19W 4-post, 45U, relay rack in MDF Room Strongtie or Hilli Anchors
Ladder rack from 2-post data racks to facility wall with wall angled brackets mounted to telco backboard and top plates mounted to racks
Ladder rack from 4-post data racks to facility wall with wall angled brackets mounted to telco backboard and top plates mounted to racks
Ladder rack between 2 and 4-post cable ladder racks connected using butt splice and junction splice kits
Ring-and-string or box and conduit provided by electrician
QTY 2 CAT6 cables at each office / cubicle location designated on the floor plan document
Hard-walled office locations need flush mount jacks using faceplates
Terminate all wire in MDF location using patch panel in 2-post rack specified in drawing
Cable support in open ceiling space using B-Line Flextray or equivalent
Cable support in drop or closed ceiling space use B-Line J Hooks or equivalent
QTY 1 Cat 6 cables at each Wireless AP location designated on floor plan
Ceiling locations terminate in surface-mount box using Leviton Extreme quickport connectors
QTY 1 Cat 6 cables at each Camera location designated on floor plan
All outdoor cable pathway to be provided by electrician w/ minimum 1" conduit and single-gang box
Outdoor locations terminate Cat 6 cable in electrician-provided single-gang box & conduit using Leviton Extreme Quickport connector (no surface mount box required)
Terminate camera Cat 6 cables in Leviton 24-port patch panel in 4-post rack designated in Rack Elevation Diagram, and Rack top-down diagram
QTY 7 Horizontal (492RU-HFR) installed between patch panels in MDF rack per elevation drawing
QTY 12 (4940L-VFR) Vertical wire management installed between racks per elevation drawing
Jack labeling should comply with following standard: 1001.A, 1001.B signifies 2 cables at each workstation, 1002.A, 1002.B signifies next 2 cables, etc.
Test all structured cable connections using Level V Series copper cable certification system or equivalent to verify all cable installs meet Cat 6 certification. Provide written

1 CONTRACTOR LOW VOLTAGE SCOPE, INSTALLATION AND SPECS
SCALE: 6" = 1'-0"

2 OWNER FURNISHED, OWNER INSTALLED LOW VOLTAGE SPECS
SCALE: 6" = 1'-0"

3 LOW VOLTAGE SCOPE DIAGRAM
SCALE: 12" = 1'-0"

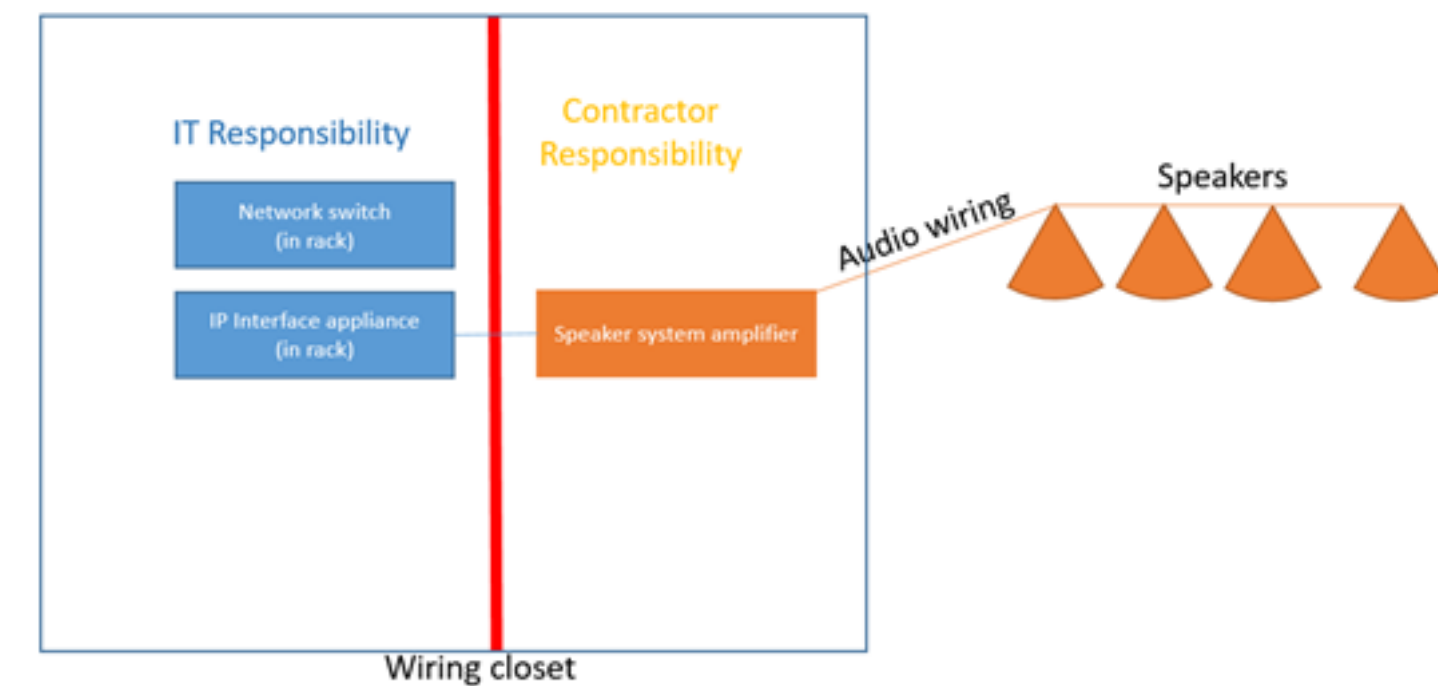

E

D

C

B

A

12/26/2019 12:56:11 PM



Architectural NEXUS, Inc. 930 R Street Sacramento, California 95811 T 916.443.5911 http://www.archnexus.com

Original drawings remain the property of the Architect and as such the Architect retains total ownership and control. The design represented by these drawings is sold to the client for a one time use, unless otherwise agreed upon in writing by the Architect. © Architectural Nexus, Inc. 2014

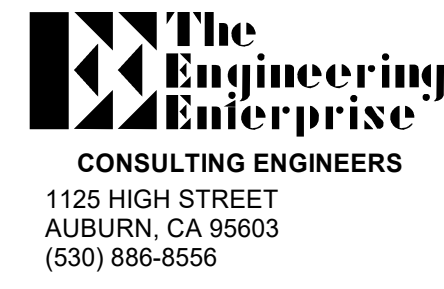

EL DORADO COUNTY EDC HHS TENANT IMPROVEMENT 368 SANDY WAY SOUTH LAKE TAHOE, CA 96150

STATE OF CALIFORNIA INDOOR LIGHTING (DC/NBC/11-01-4) (Revised 04/16) CERTIFICATE OF COMPLIANCE (Page 1 of 4) PROJECT NAME: EDC HHS Tenant Improvement DATE PREPARED: November 16, 2018

STATE OF CALIFORNIA INDOOR LIGHTING (DC/NBC/11-01-4) (Revised 04/16) CERTIFICATE OF COMPLIANCE (Page 2 of 4) PROJECT NAME: EDC HHS Tenant Improvement DATE PREPARED: November 16, 2018

STATE OF CALIFORNIA INDOOR LIGHTING (DC/NBC/11-01-4) (Revised 04/16) CERTIFICATE OF COMPLIANCE (Page 3 of 4) PROJECT NAME: EDC HHS Tenant Improvement DATE PREPARED: November 16, 2018

STATE OF CALIFORNIA INDOOR LIGHTING (DC/NBC/11-01-4) (Revised 04/16) CERTIFICATE OF COMPLIANCE (Page 4 of 4) PROJECT NAME: EDC HHS Tenant Improvement DATE PREPARED: November 16, 2018

CA Building Energy Efficiency Standards - 2016 Nonresidential Compliance April 2016

CA Building Energy Efficiency Standards - 2016 Nonresidential Compliance April 2016

CA Building Energy Efficiency Standards - 2016 Nonresidential Compliance April 2016

CA Building Energy Efficiency Standards - 2016 Nonresidential Compliance April 2016

STATE OF CALIFORNIA INDOOR LIGHTING (DC/NBC/11-01-4) (Revised 04/16) CERTIFICATE OF COMPLIANCE (Page 1 of 4) PROJECT NAME: EDC HHS Tenant Improvement DATE PREPARED: November 16, 2018

STATE OF CALIFORNIA INDOOR LIGHTING (DC/NBC/11-01-4) (Revised 04/16) CERTIFICATE OF COMPLIANCE (Page 2 of 4) PROJECT NAME: EDC HHS Tenant Improvement DATE PREPARED: November 16, 2018

STATE OF CALIFORNIA INDOOR LIGHTING - LIGHTING CONTROLS (DC/NBC/11-01-4) (Revised 04/16) CERTIFICATE OF COMPLIANCE (Page 1 of 4) PROJECT NAME: EDC HHS Tenant Improvement DATE PREPARED: November 16, 2018

STATE OF CALIFORNIA INDOOR LIGHTING - LIGHTING CONTROLS (DC/NBC/11-01-4) (Revised 04/16) CERTIFICATE OF COMPLIANCE (Page 2 of 4) PROJECT NAME: EDC HHS Tenant Improvement DATE PREPARED: November 16, 2018

CA Building Energy Efficiency Standards - 2016 Nonresidential Compliance April 2016

CA Building Energy Efficiency Standards - 2016 Nonresidential Compliance April 2016

CA Building Energy Efficiency Standards - 2016 Nonresidential Compliance January 2016

CA Building Energy Efficiency Standards - 2016 Nonresidential Compliance January 2016

STATE OF CALIFORNIA INDOOR LIGHTING - LIGHTING CONTROLS (DC/NBC/11-01-4) (Revised 04/16) CERTIFICATE OF COMPLIANCE (Page 1 of 4) PROJECT NAME: EDC HHS Tenant Improvement DATE PREPARED: November 16, 2018

STATE OF CALIFORNIA INDOOR LIGHTING POWER ALLOWANCE (DC/NBC/11-01-4) (Revised 04/16) CERTIFICATE OF COMPLIANCE (Page 1 of 4) PROJECT NAME: EDC HHS Tenant Improvement DATE PREPARED: November 16, 2018

STATE OF CALIFORNIA INDOOR LIGHTING POWER ALLOWANCE (DC/NBC/11-01-4) (Revised 04/16) CERTIFICATE OF COMPLIANCE (Page 2 of 4) PROJECT NAME: EDC HHS Tenant Improvement DATE PREPARED: November 16, 2018

STATE OF CALIFORNIA INDOOR LIGHTING POWER ALLOWANCE (DC/NBC/11-01-4) (Revised 04/16) CERTIFICATE OF COMPLIANCE (Page 3 of 4) PROJECT NAME: EDC HHS Tenant Improvement DATE PREPARED: November 16, 2018

CA Building Energy Efficiency Standards - 2016 Nonresidential Compliance January 2016

CA Building Energy Efficiency Standards - 2016 Nonresidential Compliance April 2016

CA Building Energy Efficiency Standards - 2016 Nonresidential Compliance April 2016

CA Building Energy Efficiency Standards - 2016 Nonresidential Compliance April 2016

STATE OF CALIFORNIA INDOOR LIGHTING POWER ALLOWANCE (DC/NBC/11-01-4) (Revised 04/16) CERTIFICATE OF COMPLIANCE (Page 1 of 4) PROJECT NAME: EDC HHS Tenant Improvement DATE PREPARED: November 16, 2018

STATE OF CALIFORNIA INDOOR LIGHTING POWER ALLOWANCE (DC/NBC/11-01-4) (Revised 04/16) CERTIFICATE OF COMPLIANCE (Page 2 of 4) PROJECT NAME: EDC HHS Tenant Improvement DATE PREPARED: November 16, 2018

CA Building Energy Efficiency Standards - 2016 Nonresidential Compliance April 2016

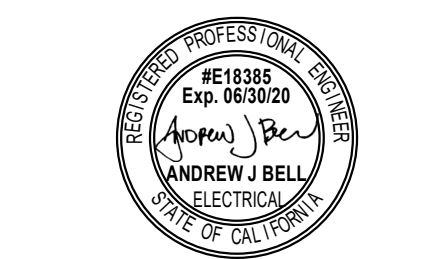

# Date Revision

CONSTRUCTION DOCUMENTS

NEXUS PROJ. #: 18117 CHECKED BY: Author DRAWN BY: ASHBY DATE: 01/02/2019

TITLE 24



ARCH | NEXUS

Architectural NEXUS, Inc.  
930 R Street  
Sacramento, California 95811  
T 916.443.5911  
http://www.archnexus.com

Original drawings remain the property of the Architect and as such the Architect retains total ownership and control. The design represented by these drawings is sold to the client for a one time use, unless otherwise agreed upon in writing by the Architect. © Architectural Nexus, Inc. 2014

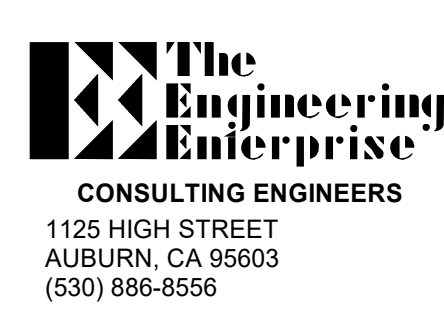

**EL DORADO COUNTY  
EDC HHS TENANT IMPROVEMENT**  
3368 SANDY WAY  
SOUTH LAKE TAHOE, CA 96150

- ### GENERAL SHEET NOTES
- EXISTING CONDUITS FEEDING EXISTING HVAC UNITS TO REMAIN.
  - CONDUITS FEEDING EXISTING RECEPTACLES IN ELECTRICAL ROOM AND EXTERIOR RECEPTACLES TO REMAIN.
  - CONDUIT FEEDING EXISTING EXTERIOR LIGHTING TO REMAIN.
  - EXISTING WALL MOUNTED CONDUITS IN EXPOSED CEILING AREAS THAT RECEIVE SCRM TO COVER INSULATION WILL NEED DRYWALL INSTALLED ON WALLS TO BOTTOM OF JOIST WHERE EXISTING WALL CONDUITS MUST REMAIN FOR EXTERIOR LIGHTING. REMOVE CONDUITS, BOXES AND TEMPORARY SUSPEND OR SUPPORT TO ALLOW FOR NEW FINISHED AND REINSTALL OR REROUTE AS NEEDED TO PROVIDE FINISH. ANY EXPOSED CONDUITS, SUPPORTS, BOXES, ON WALLS WILL NEED TO BE PAINTED.

- ### NUMBERED SHEET NOTES
- DEMO ALL EXISTING ELECTRICAL, UON. THIS INCLUDES: LIGHTING FIXTURES, LIGHTING CONTROLS, POWER DEVICES, AND EQUIPMENT. LOW VOLTAGE DEVICES AND EQUIPMENT, BOXES, CONDUIT, RACEWAYS, AND WIRING, AS REQUIRED FOR NEW WORK AS SHOWN ON NEW DRAWINGS.
  - DEMO ROLL UP DOOR.
  - DEMO EXISTING FACP, AND MDF WIRING AND EQUIPMENT. EXISTING FIBER AND PHONE LINES ARE TO REMAIN AND BE PROTECTED DURING DEMO WORK.
  - EXISTING UNISTRUT AND CONDUIT TO EXISTING HVAC UNIT TO REMAIN.

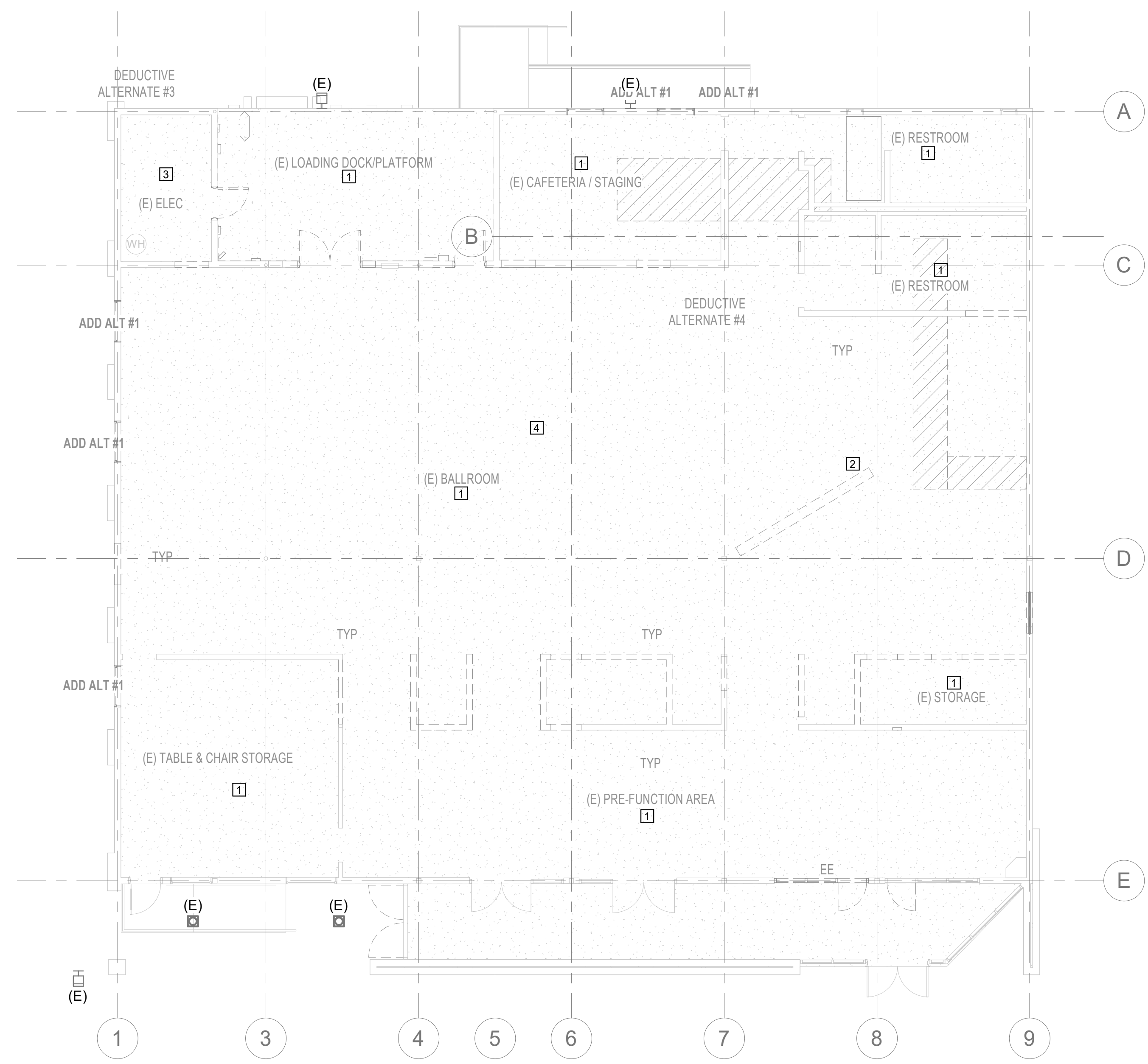

**1 DEMO PLAN - LEVEL 01**  
SCALE: 1/8" = 1'-0"

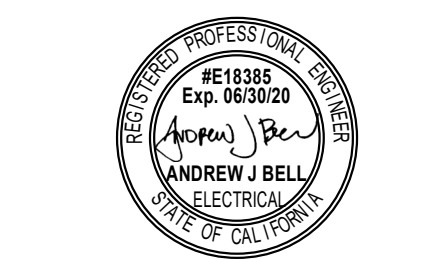

# Date Revision

**CONSTRUCTION DOCUMENTS**

NEXUS PROJ. #: 18117  
CHECKED BY: Checker  
DRAWN BY: Author  
DATE: 01/02/2019

**DEMO PLAN**





ARCH | NEXUS

Architectural NEXUS, Inc.  
930 R Street  
Sacramento, California 95811  
T 916.443.5911  
http://www.archnexus.com

Original drawings remain the property of the Architect and as such the Architect retains total ownership and control. The design represented by these drawings is sold to the client for a one time use, unless otherwise agreed upon in writing by the Architect. © Architectural Nexus, Inc. 2014

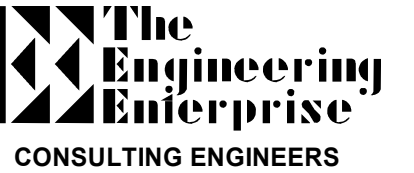

CONSULTING ENGINEERS  
1125 HIGH STREET  
AUBURN, CA 95603  
(530) 896-8556

EL DORADO COUNTY  
**EDC HHS TENANT IMPROVEMENT**  
3368 SANDY WAY  
SOUTH LAKE TAHOE, CA 96150

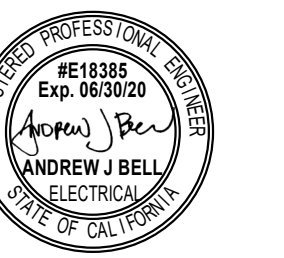

# Date Revision

### GENERAL SHEET NOTES

1. PROVIDE PRICING FOR ALT WORK SCOPE, EXISTING TO REMAIN.
2. REFER TO DETAIL 2/E601 FOR SURFACE MOUNTED FIXTURE DETAIL.

### NUMBERED SHEET NOTES

- 1 EXISTING EXTERIOR LIGHT FIXTURE TO REMAIN.
- 2 LOCATE EXISTING LIGHTING CIRCUIT, INTERCEPT AND EXTEND TO NEW LIGHTING CONTROL SYSTEM AS SHOWN, TYPICAL FOR ALL EXTERIOR LIGHTING FIXTURES, UON.
- 3 UNDER CABINET LIGHT FIXTURE. REFER TO DETAIL 6/E601 FOR ADDITIONAL INSTALLATION INFORMATION.

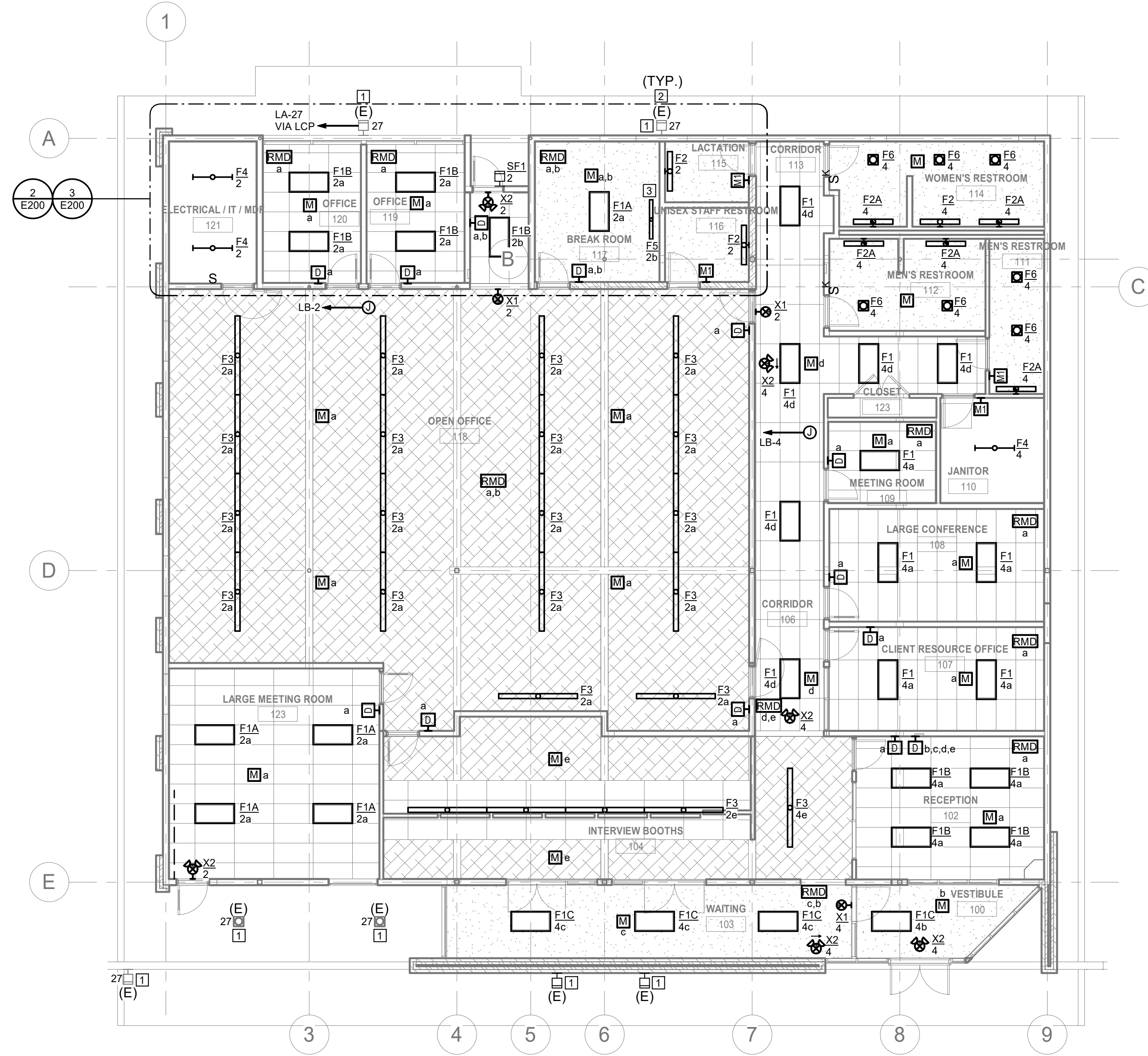

**1 LIGHTING PLAN**  
SCALE: 1/8" = 1'-0"

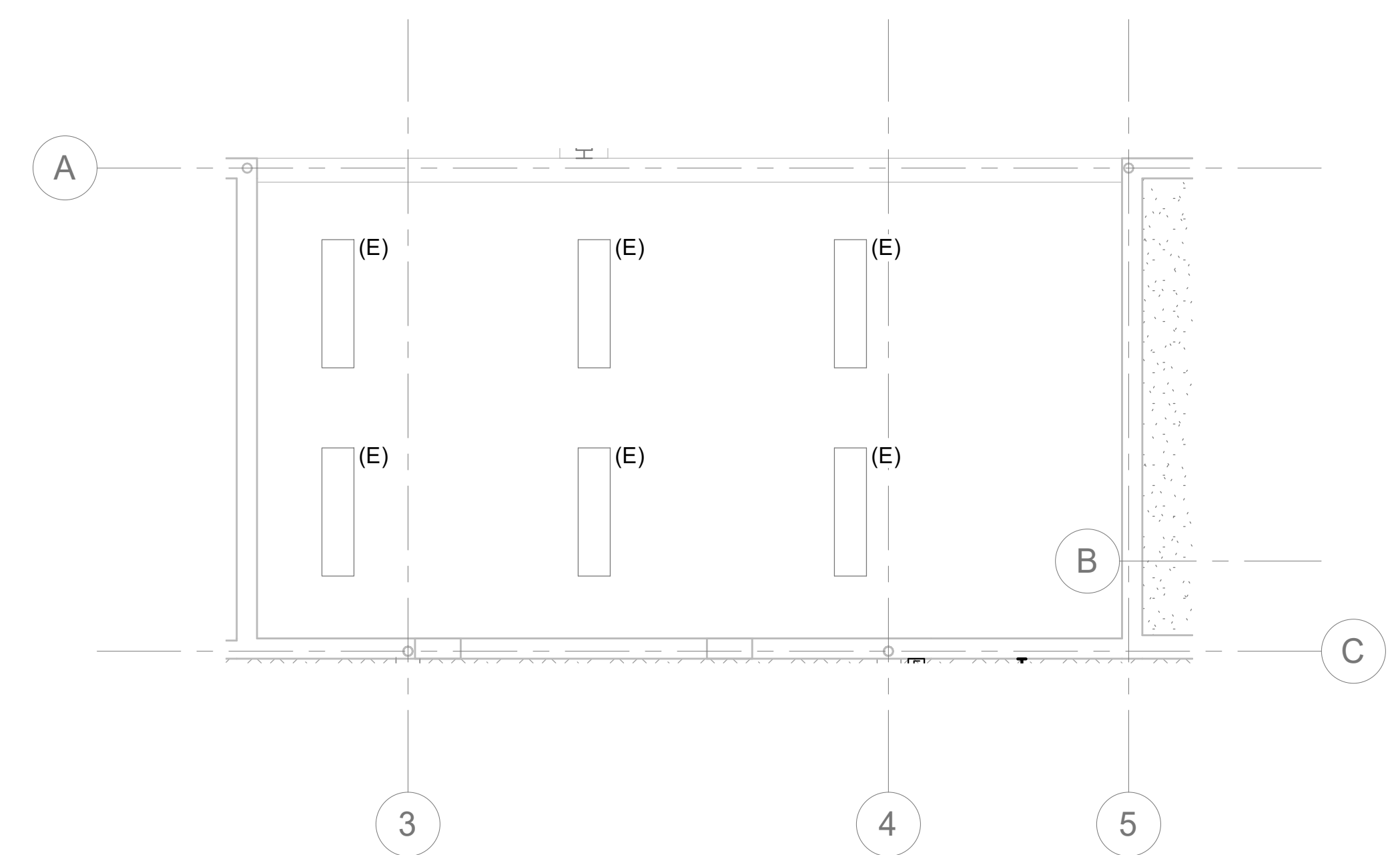

**2 LIGHTING PLAN - ALT#3**  
SCALE: 1/4" = 1'-0"

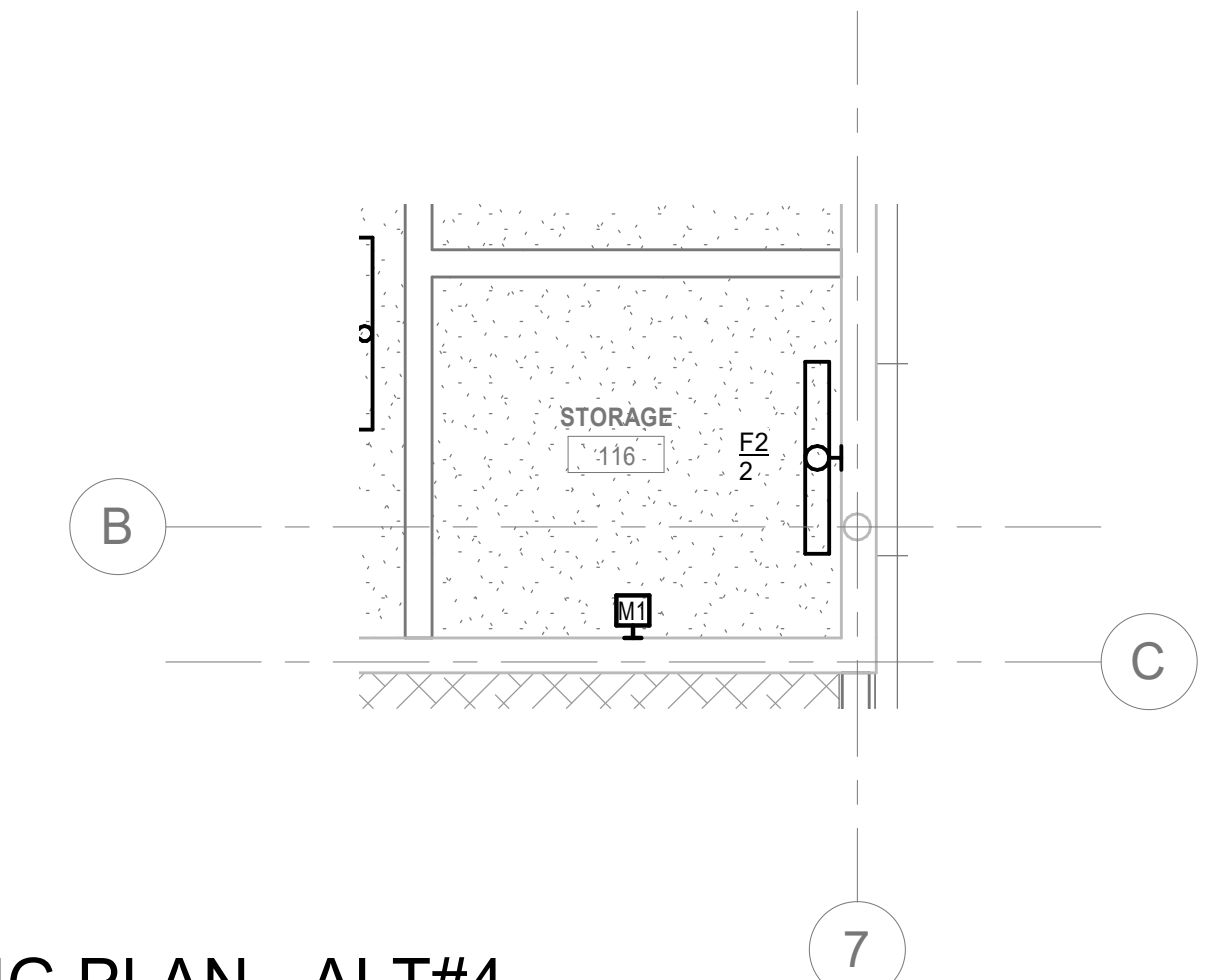

**3 LIGHTING PLAN - ALT#4**  
SCALE: 1/4" = 1'-0"

12/26/2019 12:50:16 PM

### CONSTRUCTION DOCUMENTS

NEXUS PROJ. #: 18117  
 CHECKED BY: Checker  
 DRAWN BY: Andrew J. Bell  
 DATE: 01/02/2019

### LIGHTING PLAN

**E200**  
 18-1912 Revised B 113 of 606  
 BOS Rcvd 1-24-19



ARCH | NEXUS

Architectural NEXUS, Inc.  
930 R Street  
Sacramento, California 95811  
T 916.443.5911  
http://www.archnexus.com

Original drawings remain the property of the Architect and as such the Architect retains total ownership and control. The design represented by these drawings is sold to the client for a one time use, unless otherwise agreed upon in writing by the Architect. © Architectural Nexus, Inc. 2014

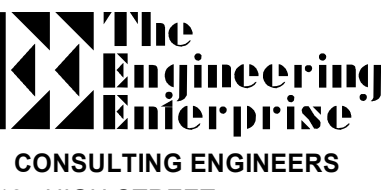

CONSULTING ENGINEERS  
1125 HIGH STREET  
AUBURN, CA 95603  
(530) 886-8556

EL DORADO COUNTY  
**EDC HHS TENANT IMPROVEMENT**  
3368 SANDY WAY  
SOUTH LAKE TAHOE, CA 96150

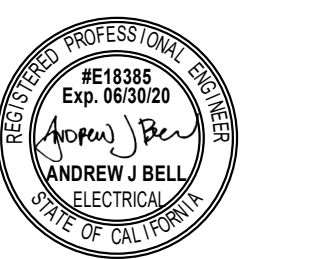

# Date Revision

**CONSTRUCTION DOCUMENTS**

NEXUS PROJ. #: 18117  
CHECKED BY: Checker  
DRAWN BY: Andrew J. Bell  
DATE: 01/02/2019

**POWER & SIGNAL PLAN**

**E300**  
18-1912 Revised B 11/14 of 606  
BOS Rcvd 1-24-19

- ### GENERAL SHEET NOTES
- INTRUSION BURGLAR ALARM AND ACCESS CONTROLS ARE TO BE WORKING OFF THE SAME KEY FOBS. CONTRACTOR TO TEST AND VERIFY SECURITY SYSTEM IS OPERATIONAL.
  - ALL CAMERA CABLING SHALL BE PROVIDED AND INSTALLED BY CONTRACTOR. REFER TO SECURITY CAMERA SCHEDULE ON THIS SHEET FOR CAMERA TYPES, MANUFACTURER AND CATALOG NUMBER. TERMINATE CAMERA CAT6 CABLE IN LEVITON 24-PORT PATCH PANEL IN 4-POST RACK AT MDF. CAMERAS SYSTEM INCLUDING MOUNTING HARDWARE SHALL BE OFCI.
  - SECURITY SYSTEM AND COMPONENTS SHALL BE SONITROL UON.
  - ALL LOW VOLTAGE CABLING SHALL BE BLACK UON.
  - EXPOSED OPEN CEILING CONDUITS, SUPPORTS AND ANCHOR RINGS TO BE PAINTED TO MATCH CEILING/STRUCTURE ABOVE.
  - PRIOR TO INSTALLATION OF SWITCHES AND OPERATING SOFTWARE, FACTOR ADDITIONAL 5 HOURS ON SITE WORK TO BE SCHEDULED AT A LATER TIME, FOR FINE-TUNING AND ADJUSTMENT FOR CAMERA SYSTEM. COORDINATE WITH OWNER FOR CAMERA ANGLES AND ZOOM NEEDS.
  - PROVIDE PRICING FOR ALT WORK SCOPE, EXISTING TO REMAIN.
  - REFER TO SHEET E002 FOR ADDITIONAL LOW VOLTAGE SPECS AND CONTRACTOR SCOPE AND INSTRUCTIONS.
  - ALL CABLES SHALL BE SUPPORTED WITH J-HOOKS, SUPPORTED EVERY 48".

- ### NUMBERED SHEET NOTES
- PROVIDE MAIN GROUND BAR ON 3/4" FIRE-RATED BACKBOARD, IF NOT READILY VISIBLE, INSTALL UFER-COMPLIANT GROUND POST IN MDF. PROVIDE AND RUN #6 GROUND WIRE AND ATTACH TO VISIBLE UFER GROUND. SEE GROUND RISER DIAGRAM ON E6.00.
  - PROVIDE GROUND BAR (GB-MDF) ON TOP OF ALL RACKS. PROVIDE AND RUN #6 GROUND WIRE TO RACK GROUNDING BAR AND RUN #6 WIRE TO MAIN GROUND BAR INSTALLED ON BACKBOARD.
  - PROVIDE AND INSTALL SEVEN (7) HORIZONTAL (402RU-HFR) CABLE MANAGERS BETWEEN PATCH PANELS. PROVIDE AND INSTALL AND TWELVE (12) VERTICAL (4840L-VFR) WIRE MANAGERS BETWEEN RACKS. REFER TO SHEET E002 FOR ADDITIONAL INFO AND SPECS.
  - PROVIDE NEW 3/4" FIRE-RATED BACKBOARD.
  - PROVIDE TELECOM CONNECTION FOR OVERHEAD PAGING/INTERCOM SYSTEM FOR LOBBY AND WAITING AREA.
  - PROVIDE MINIMUM 1" CONDUIT THROUGH ACCESSIBLE CEILING SPACE TO CAMERA, AND SINGLE-GANG J-BOX, TO EXTERIOR CAMERAS ONLY. TERMINATE CAT6 CABLE IN J-BOX USING LEVITON EXTREME QUICKPORT CONNECTOR WITH SMB. POE INJECTOR INCLUDED WITH CAMERA. NO ADDITIONAL CABLING NEEDED FOR CAMERA HEATER.
  - PROVIDE DEDICATED 20A RECEPTACLE FOR RACK. REFER TO DETAIL 7/E001 FOR TYPICAL FURNITURE TERMINATION DETAIL.
  - PROVIDE TWO (2) RECEPTACLES FOR ACCESS CONTROL PANEL AND BURGLAR ALARM.
  - FUTURE USE LOW VOLTAGE CABLE. LEAVE UNTERMINATED IN CEILING WITH 10' SERVICE LOOP.
  - PROVIDE ONE CABLE TO DATA DROP AND TERMINATE CABLES USING FLUSHMOUNT WALL PLATE BEHIND TV UNIT ON WALL.
  - PROVIDE POWER AND ONE (1) DATA CABLE CONNECTION FOR SELF CHECK-IN KIOSK. REFER TO DETAIL 4/E001 FOR TYPICAL WALL CABLE TERMINATION PLATE DETAIL.
  - PROVIDE FURNITURE PARTITION WHIP FEED. TERMINATE AT EACH WORKSTATION. CABLE SHALL NOT BE ROUTED ABOVE THE OPEN OFFICE SPACE.
  - TERMINATE AT SPEAKER AMP LOCATED IN MDF. SEE DETAIL 4/E001 FOR WIRING DIAGRAM, DETAIL 3/E002 FOR CONTRACTOR SPEAKER SCOPE.
  - PROVIDE POWER FOR GARBAGE DISPOSAL BELOW SINK.
  - SONITROL ARMING KEYPAD.
  - PROVIDE 7FTX19W, 4-POST, 45U RELAY RACKS. PROVIDE SRONGTIE OR HILTI ANCHORS. REFER TO SHEET E002 FOR ADDITIONAL INFO AND SPECS.
  - PROVIDE 7FTX19W, 2-POST, 45U RELAY RACKS. PROVIDE SRONGTIE OR HILTI ANCHORS. REFER TO SHEET E002 FOR ADDITIONAL INFO AND SPECS.
  - LADDER RACK FROM POST DATA RACKS TO FACILITY WALL WITH WALL ANGED BRACKETS MOUNTED TO TELCO BACKBOARD AND TOP PLATES MOUNTED TO RACKS. LADDER RACK BETWEEN 2 AND 4-POST CABLE LADDER RACKS CONNECTED USING BUTT SPLICE AND JUNCTION SPLICE KITS. REFER TO SHEET E002 FOR ADDITIONAL INFO AND SPECS.
  - REFER TO DETAIL 5/E001 FOR ADDITIONAL INFO. TYPICAL OF ALL DOOR MONITORING ACCESS INTRUSION DEVICES.
  - REFERENCE DETAIL 1/E001 AND 3/E001, WHERE INSULATED WALL OR FIRE RATED WALL PENETRATION IS REQUIRED. TYPICAL OF ALL LOCATIONS.
  - TERMINATE WITH 2 PORT, SURFACE MOUNTED BOX.

SECURITY CAMERA SCHEDULE							
CAMERA	MANUFACTURER & CATALOG NUMBER	COVERAGE	INDOOR/OUTDOOR	HEATED (Y/N)	ROTATION (DEGREE)	DESCRIPTION	CONNECTION TYPE
C-A	HIKVISION DS-2CD28D54FWD-I2HS	PANO	OUTDOOR	Y	180	OUTSIDE SE DOOR. MUST COVER PARKING LOT.	WMP-PV RJ-45 CAT6
C-C	HIKVISION DS-2CD2785FWD-I2S	DOME	INDOOR	N	90	RECEPTION AREA.	MOUNT TO DROP CEILING RJ-45 CAT6
C-D	HIKVISION DS-2CD2785FWD-I2S	DOME	INDOOR	N	90	CLIENT RESOURCE CENTER.	MOUNT TO CEILING RJ-45 CAT6
C-E	HIKVISION DS-2CD2785FWD-I2S	DOME	INDOOR	N	90	LARGE CONFERENCE.	MOUNT TO CEILING RJ-45 CAT6
C-F	HIKVISION DS-2CD2685FWD-I2S	BULLET	INDOOR	N	90	WAITING ROOM.	MOUNT ON WALL RJ-45 CAT6
C-G	HIKVISION DS-2CD2785FWD-I2S	DOME	INDOOR	N	90	INTERVIEW BOOTHS. MUST BE ABLE TO VIEW CLIENT SIDE OF BOOTH.	CPM RJ-45 CAT6
C-J	HIKVISION DS-2CD5A85G0-I2HS	BULLET	OUTDOOR	Y	90	MUST COVER REAR DOOR.	CB140PT RJ-45 CAT6
C-K	HIKVISION DS-2CD6D54FWD-I2HS	PANO	OUTDOOR	Y	180	MUST COVER PARKING LOT.	WML RJ-45 CAT6
C-L	HIKVISION DS-2CD2785FWD-I2S	DOME	INDOOR	N	90	CORRIDOR.	MOUNT TO CEILING RJ-45 CAT6
C-N	HIKVISION DS-2CD2685FWD-I2S	BULLET	INDOOR	N	90	MUST COVER DOOR.	MOUNT ON WALL RJ-45 CAT6
C-P	LOGITECH C-3300E				N/A	VIDEO CONFERENCE SYSTEM	

NOTES:  
- CAMERA SYSTEM OFCI  
- CABLING BY GENERAL CONTRACTOR

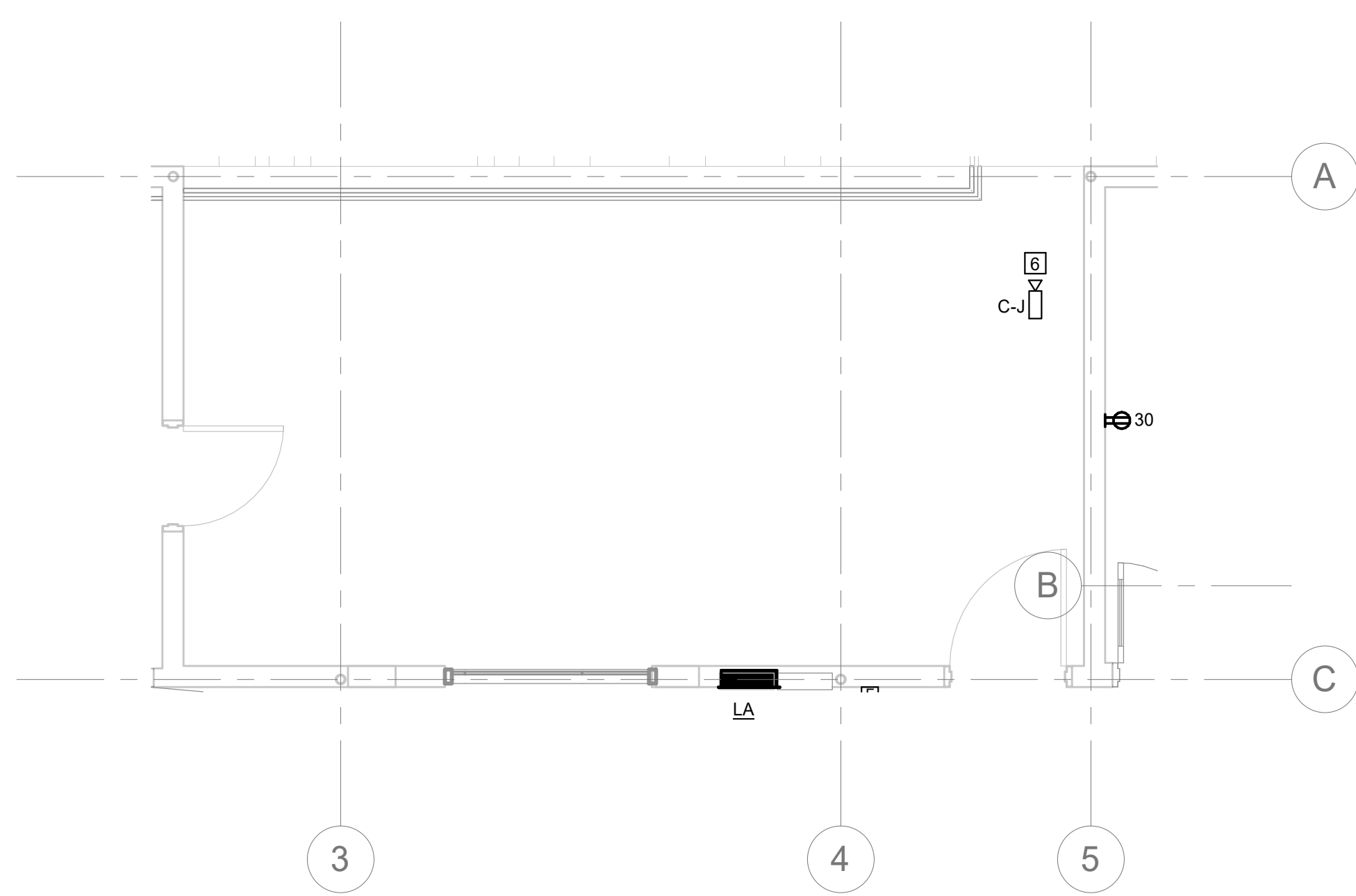

**2 POWER & SIGNAL PLAN - ALT#3**  
SCALE: 1/4" = 1'-0"

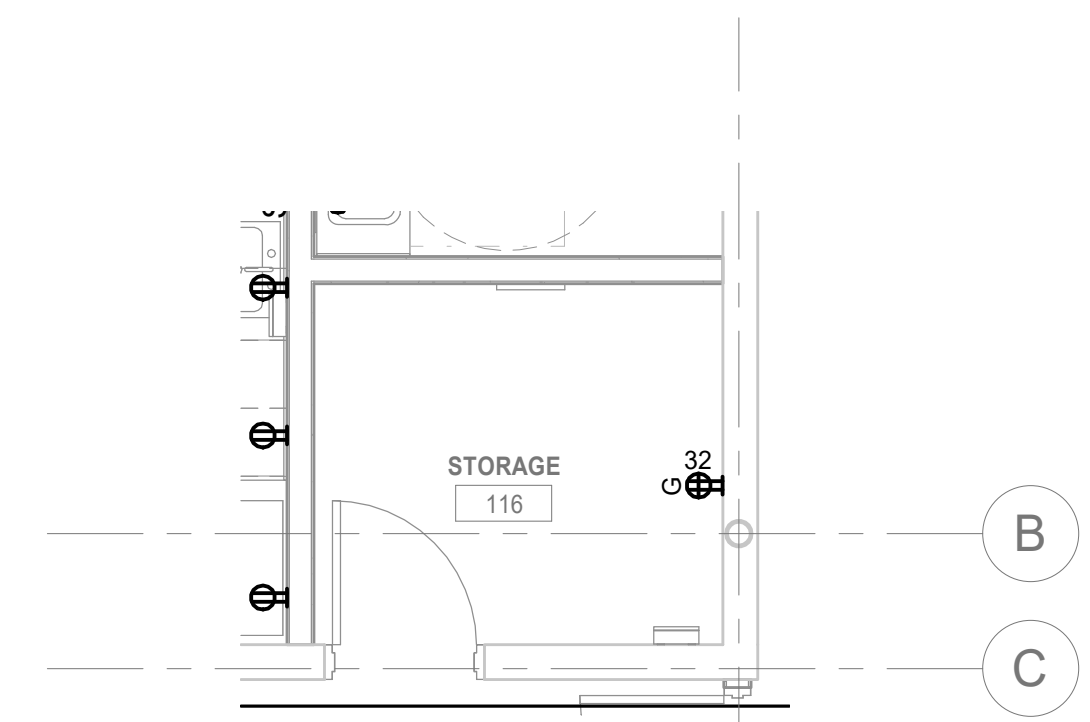

**3 POWER & SIGNAL PLAN - ALT#4**  
SCALE: 1/4" = 1'-0"

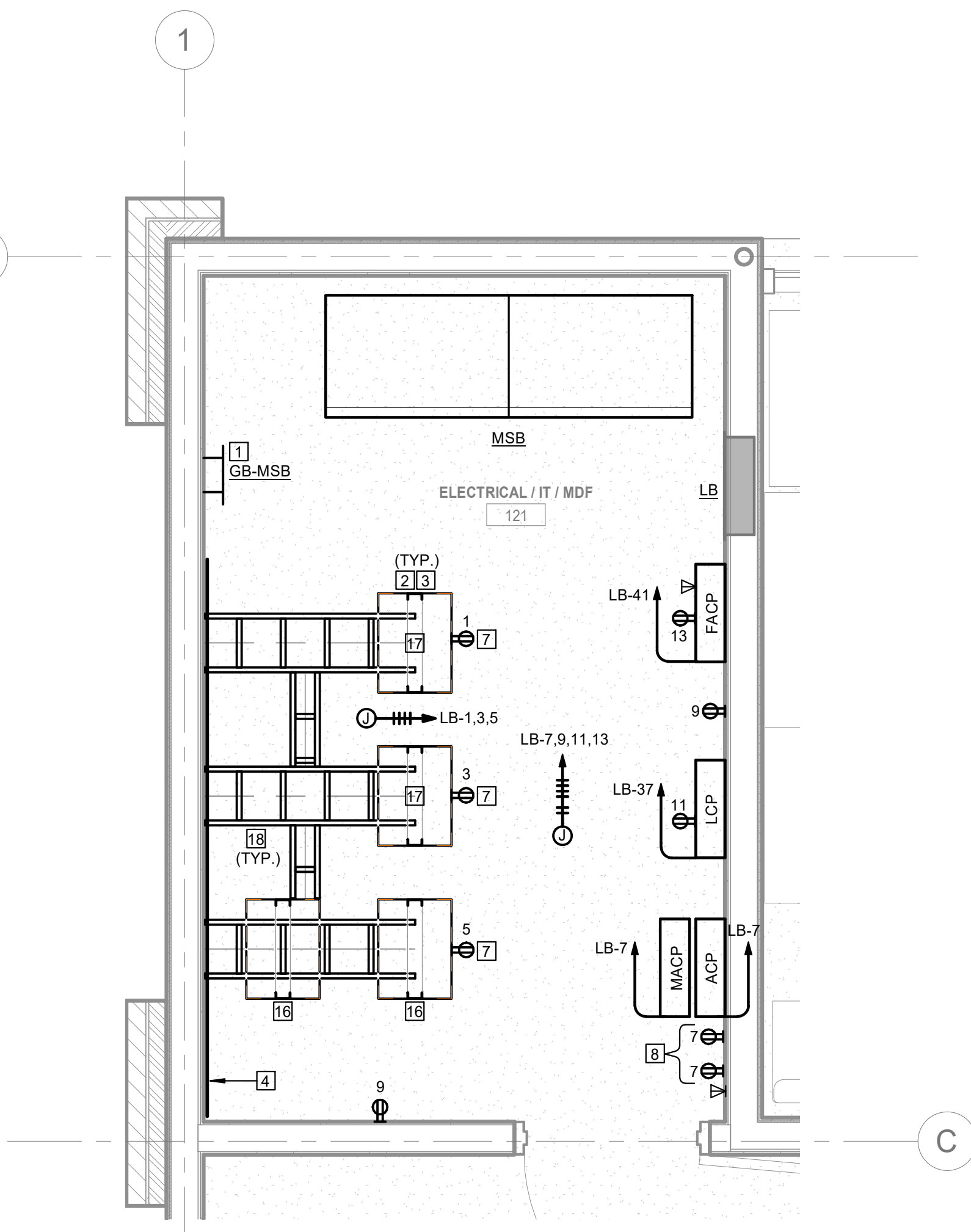

**4 ELECTRICAL/IT/MDF ROOM ENLARGEMENT**  
SCALE: 1/2" = 1'-0"

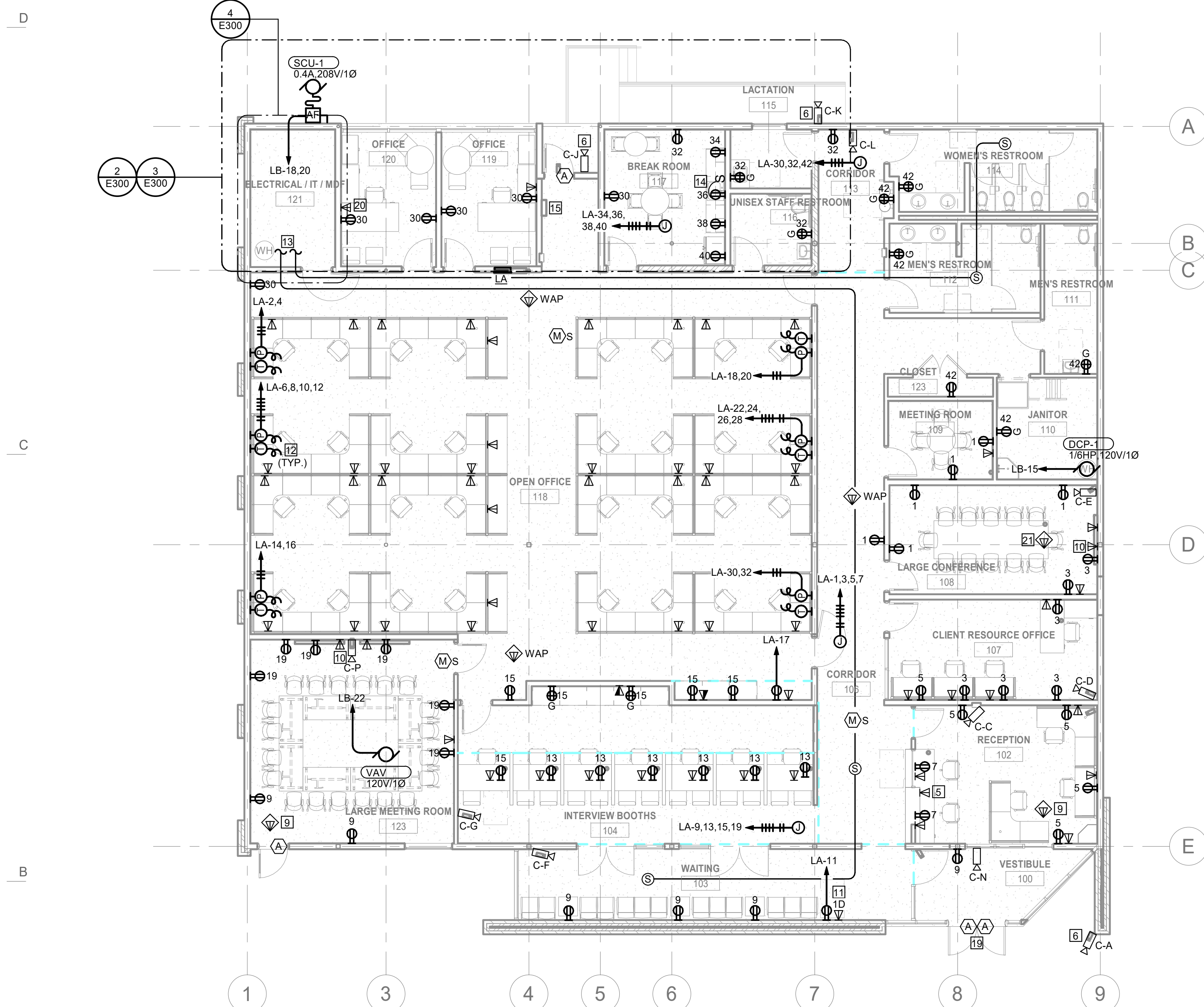

**1 POWER & SIGNAL PLAN**  
SCALE: 1/8" = 1'-0"

12/26/2019 12:50:17 PM

**GENERAL SHEET NOTES**

1. PROVIDE NEW CONDUITS AND CONDUCTORS AS NEEDED FOR HOMERUNS.

**NUMBERED SHEET NOTES**

1. PROVIDE 20A RECEPTACLE. FIELD COORDINATE EXACT LOCATION. TYPICAL.



ARCH | NEXUS

Architectural NEXUS, Inc.  
930 R Street  
Sacramento, California 95811  
T 916.443.5911  
http://www.archnexus.com

Original drawings remain the property of the Architect and as such the Architect retains total ownership and control. The design represented by these drawings is sold to the client for a one time use, unless otherwise agreed upon in writing by the Architect.  
© Architectural Nexus, Inc. 2014

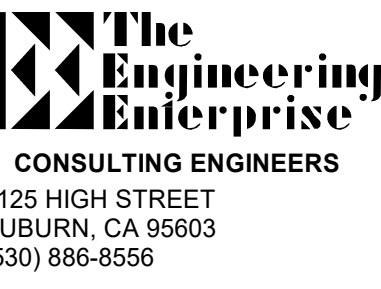

CONSULTING ENGINEERS

1125 HIGH STREET  
AUBURN, CA 95603  
(530) 896-8556

EL DORADO COUNTY  
**EDC HHS TENANT IMPROVEMENT**  
3368 SANDY WAY  
SOUTH LAKE TAHOE, CA 96150

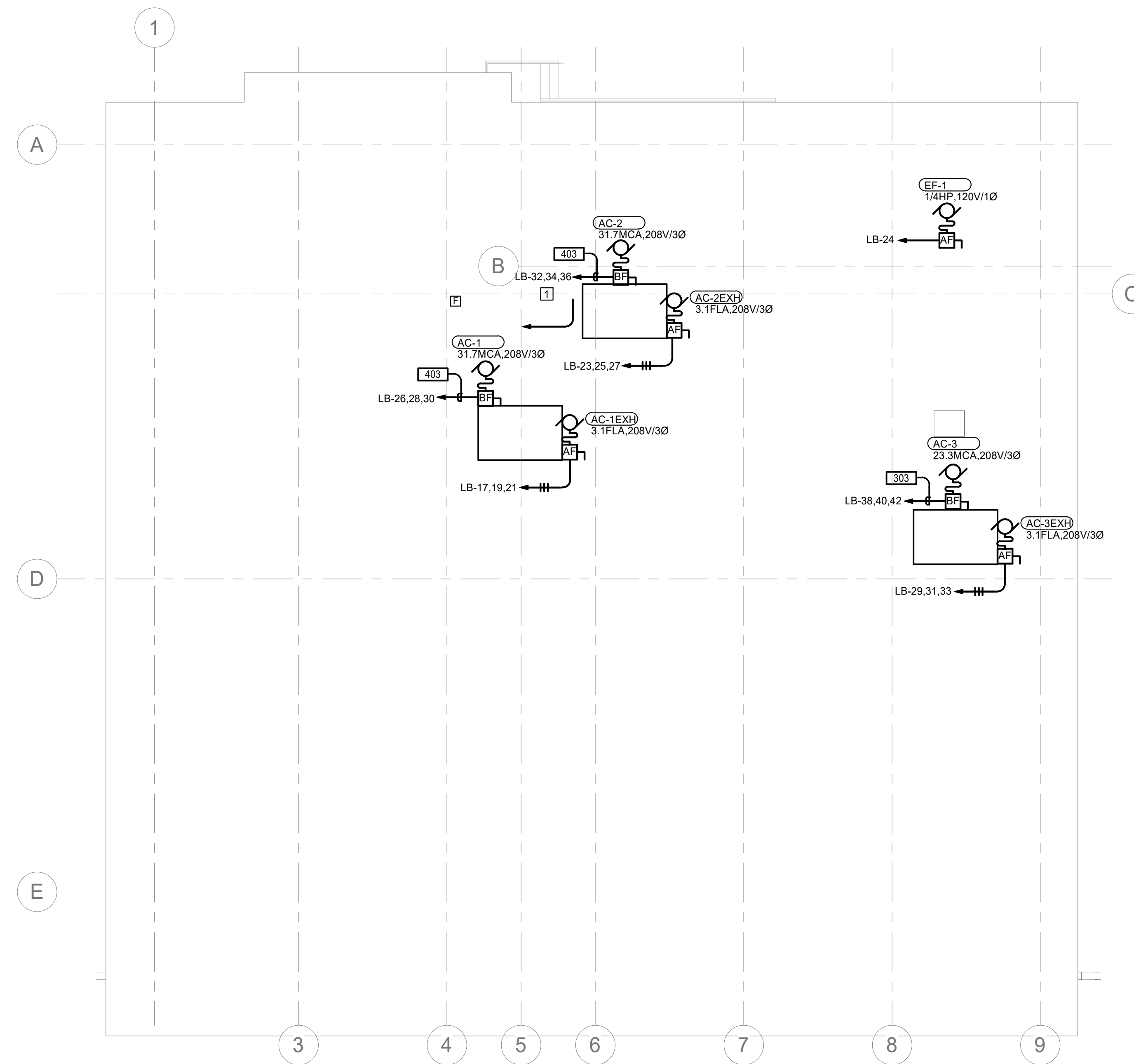

**1 POWER & SIGNAL PLAN - ROOF**  
SCALE: 1/8" = 1'-0"

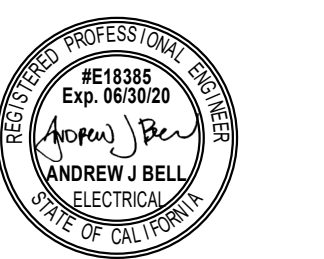

# Date Revision

**CONSTRUCTION DOCUMENTS**

NEXUS PROJ. #: 18117  
CHECKED BY: Checker  
DRAWN BY: Author  
DATE: 01/02/2019

**POWER & SIGNAL PLAN - ROOF**

**E301**

18-1912 Revised B 115 of 606  
BOS Rcvd 1-24-19

**GENERAL SHEET NOTES**

1. PROVIDE PRICING FOR ALT WORK SCOPE. EXISTING TO REMAIN.

**NUMBERED SHEET NOTES**

1. PROVIDE CONTROL RELAY FOR INTEGRAL SHUTDOWN OF HVAC UNIT. UNIT SHALL BE PROVIDED WITH INTEGRAL SMOKE DUCT DETECTION AND INTERLOCKED FOR SHUTDOWN VIA THE FIRE ALARM CONTROL PANEL.



ARCH | NEXUS  
 Architectural NEXUS, Inc.  
 930 R Street  
 Sacramento, California 95811  
 T 916.443.5911  
 http://www.archnexus.com

Original drawings remain the property of the Architect and as such the Architect retains total ownership and control. The design represented by these drawings is sold to the client for a one time use, unless otherwise agreed upon in writing by the Architect.  
 © Architectural Nexus, Inc. 2014

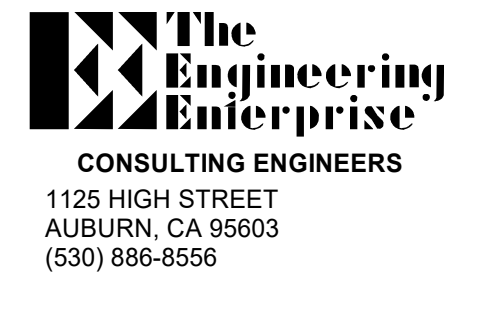

**EL DORADO COUNTY  
 EDC HHS TENANT IMPROVEMENT**  
 3368 SANDY WAY  
 SOUTH LAKE TAHOE, CA 96150

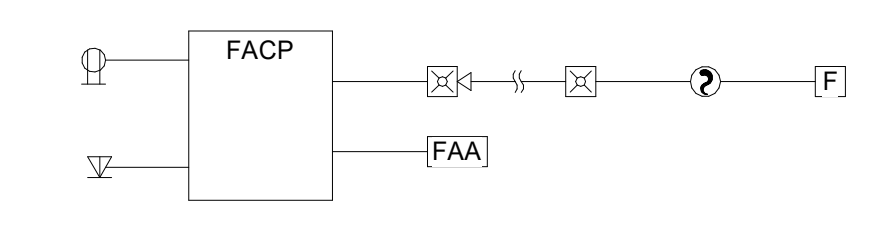

**4 Fire Alarm Riser Diagram**  
 SCALE: 12" = 1'-0"

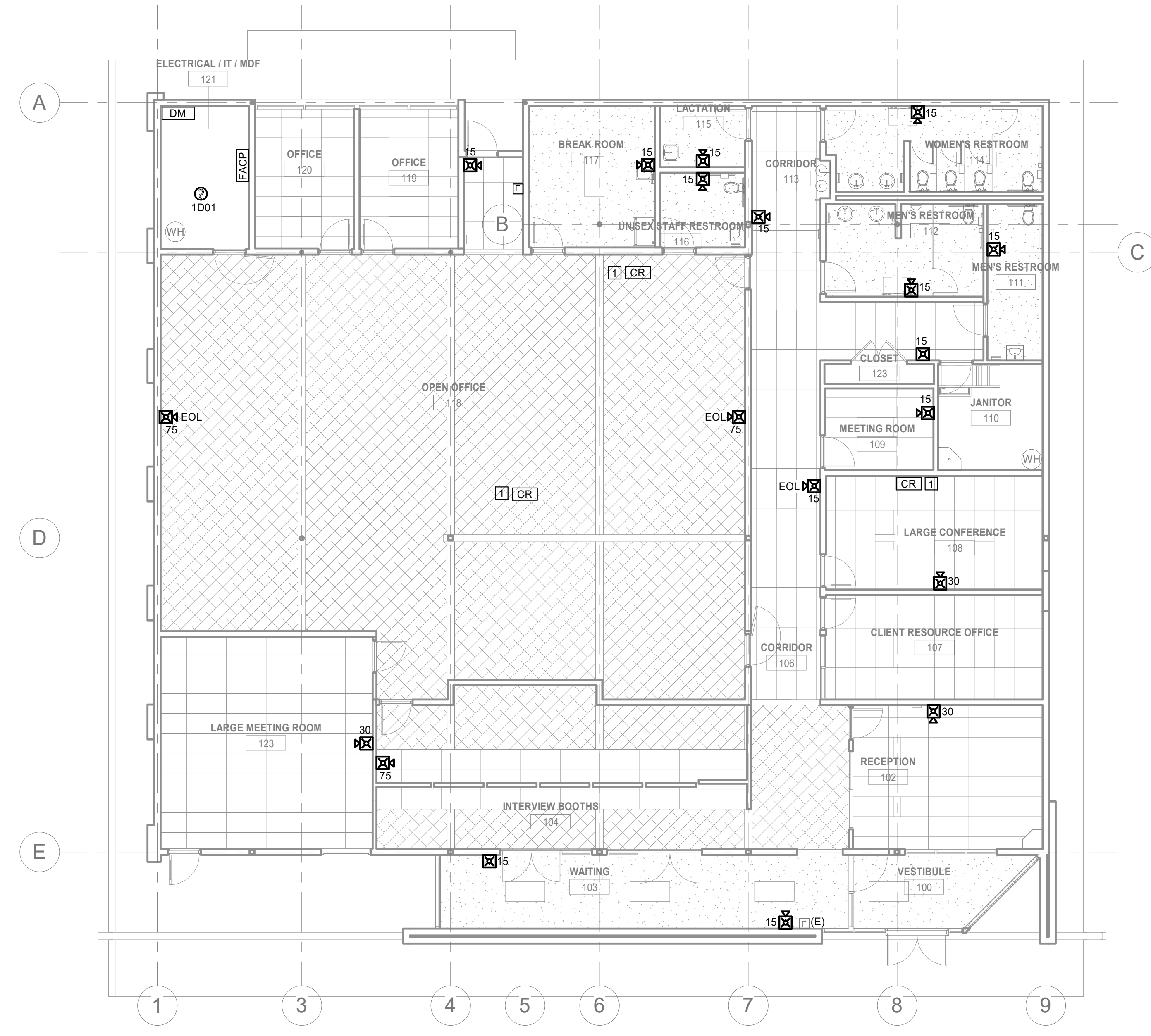

**1 FIRE ALARM PLAN - LEVEL 01**  
 SCALE: 1/8" = 1'-0"

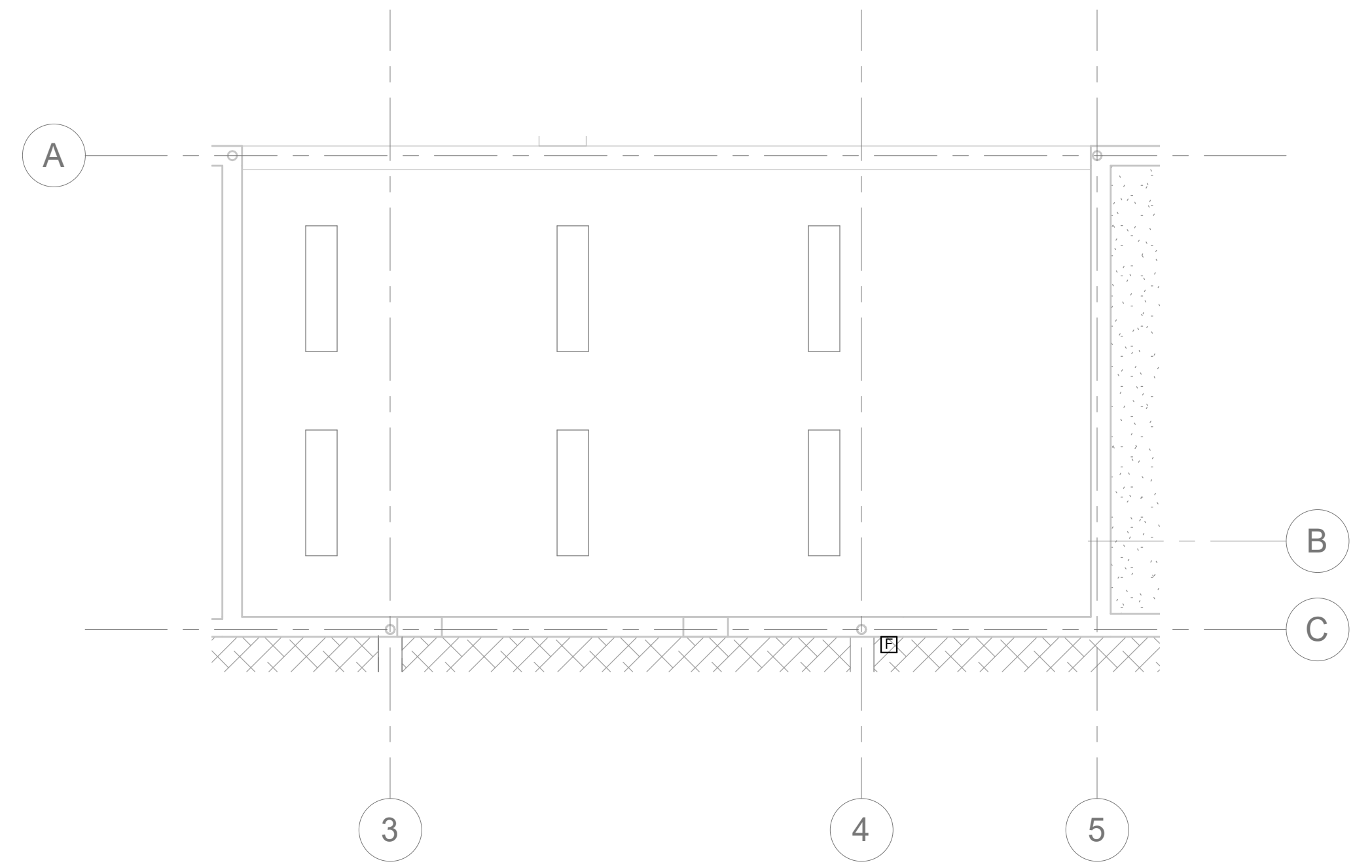

**2 FIRE ALARM PLAN - ALT#3**  
 SCALE: 1/4" = 1'-0"

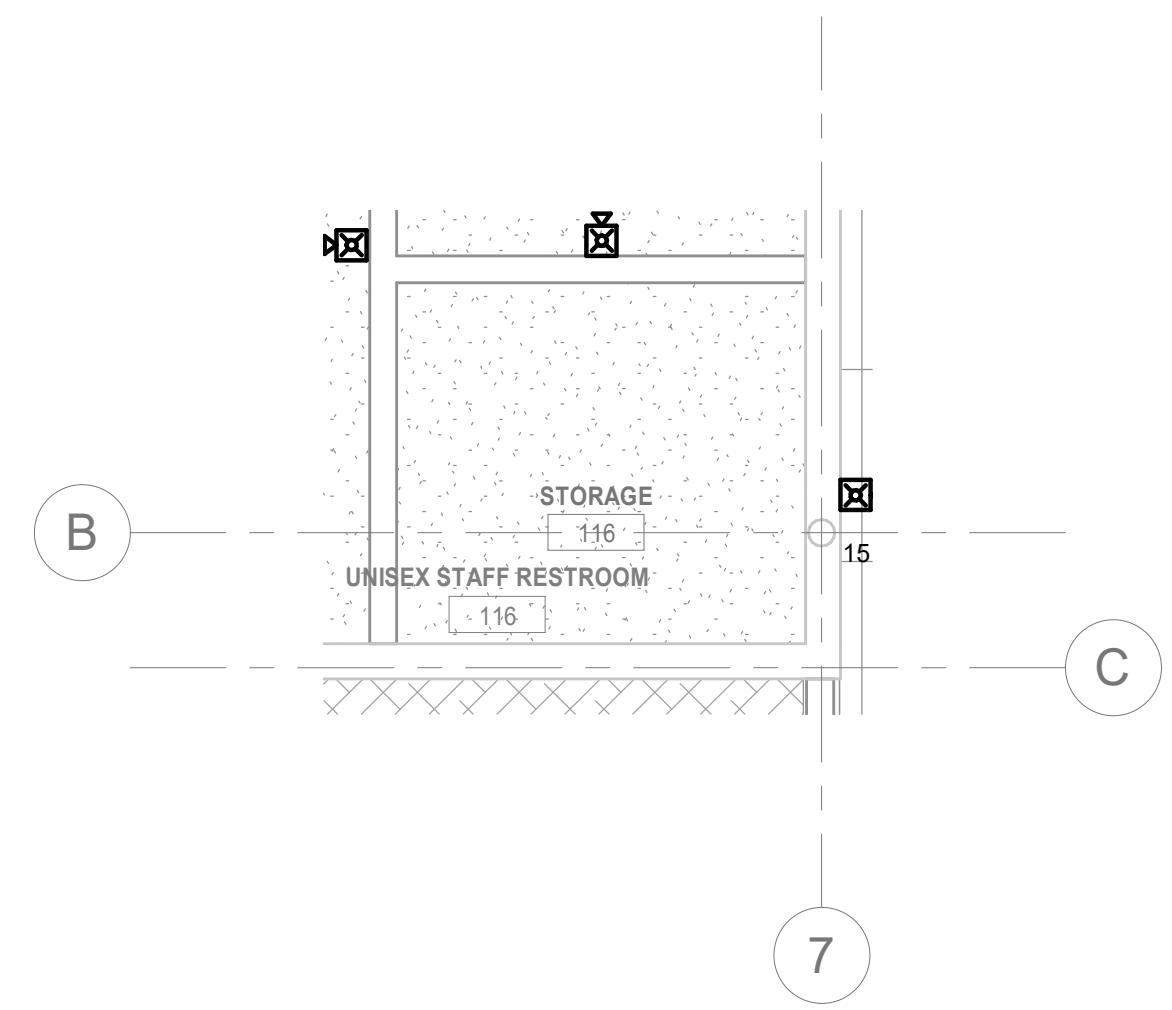

**3 FIRE ALARM PLAN - ALT#4**  
 SCALE: 1/4" = 1'-0"

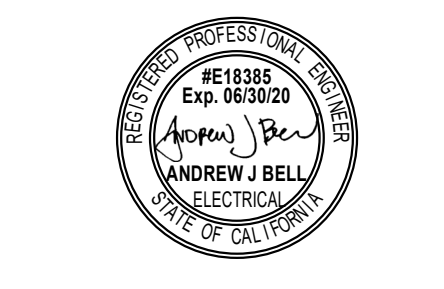

# Date Revision

**CONSTRUCTION DOCUMENTS**

NEXUS PROJ. #: 18117  
 CHECKED BY: Checker  
 DRAWN BY: Author  
 DATE: 01/02/2019

**FIRE ALARM PLAN**



ARCH | NEXUS

Architectural NEXUS, Inc.  
930 R Street  
Sacramento, California 95811  
T 916.443.5911  
http://www.archnexus.com

Original drawings remain the property of the Architect and as such the Architect retains total ownership and control. The design represented by these drawings is sold to the client for a one time use, unless otherwise agreed upon in writing by the Architect. © Architectural Nexus, Inc. 2014



CONSULTING ENGINEERS  
1125 HIGH STREET  
AUBURN, CA 95603  
(530) 886-8556

EL DORADO COUNTY  
**EDC HHS TENANT IMPROVEMENT**  
3368 SANDY WAY  
SOUTH LAKE TAHOE, CA 96150

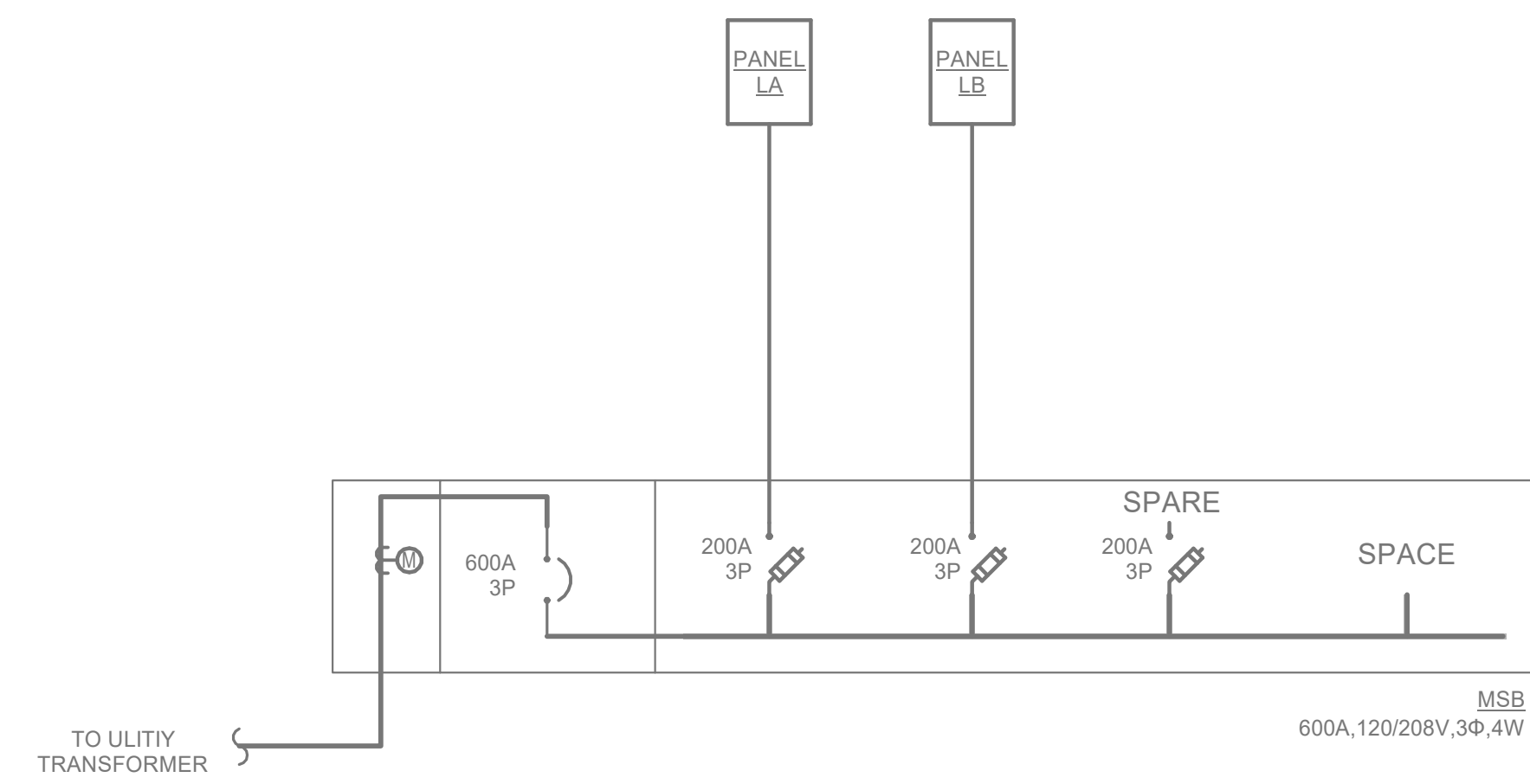

**1** POWER ONE-LINE DIAGRAM  
SCALE: 12" = 1'-0"

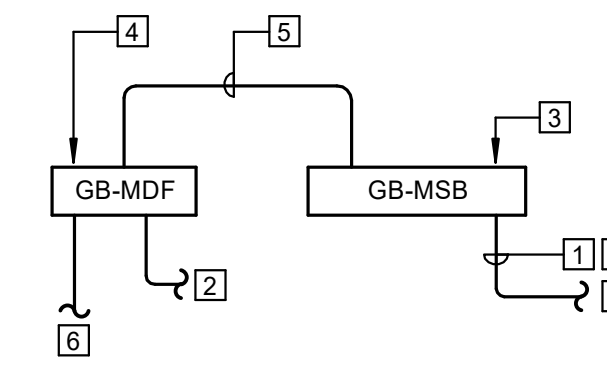

- 1 PROVIDE GROUND CONNECTION TO EXISTING GROUND/SULFER IN THE ELECTRICAL ROOM.
- 2 PROVIDE GROUND CONNECTION TO EACH TELECOM RACK SEE SHEET 2/E3.00.
- 3 PROVIDE 24" COPPER GROUND BAR.
- 4 PROVIDE GROUND BAR SEE SHEET 2/E3.00.
- 5 GROUND BAR. PROVIDE 1.25°C WITH 20 COPPER GROUND CONDUCTOR.
- 6 PROVIDE #6 COPPER BONDING CONDUCTOR TO EACH CABLE TRAY.
- 7 PROVIDE #6 GROUND WIRE TO UFER GROUND IN MDF.

**2** GROUND RISER DIAGRAM  
SCALE: 12" = 1'-0"

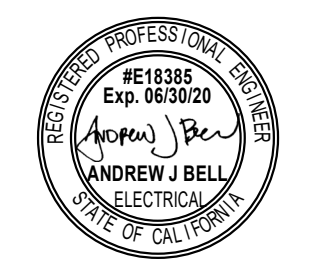

# Date Revision

**CONSTRUCTION DOCUMENTS**

NEXUS PROJ. #: 18117  
CHECKED BY: Checker  
DRAWN BY: Author  
DATE: 01/02/2019

**POWER ONE-LINE DIAGRAM**

**E500**

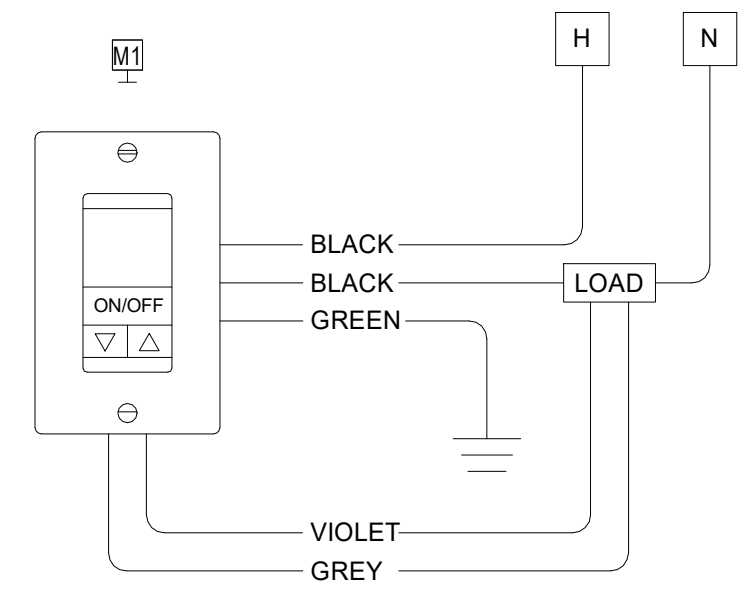

**SINGLE RELAY WALL MOUNTED DUAL-TECHNOLOGY OCCUPANCY SENSOR**  
 No neutral wiring required at device.  
 Typical at any room with wallbox occupancy sensor U.O.N.  
 Set time delay to 5 min, sensitivity to max.  
 Primary load (switchleg 'a') is automatic on, automatic off  
 Provide 0-10V control wiring to all dimmable fixtures, not shown on plans.

**1 Single Level Wallbox Sensor**

SCALE: NTS

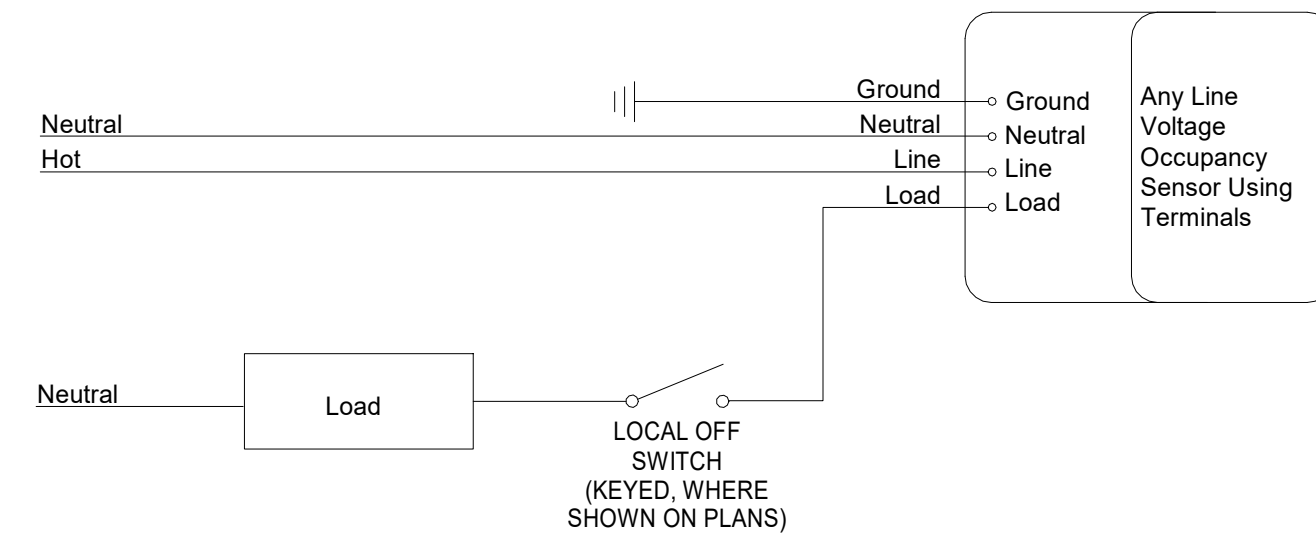

**LINE VOLTAGE CEILING MOUNTED DUAL-TECHNOLOGY OCCUPANCY SENSOR**  
 Typical at multi-user restrooms  
 Set time delay to 20 min., sensitivity to max.

**2 Line Voltage Ceiling Sensor**

SCALE: NTS

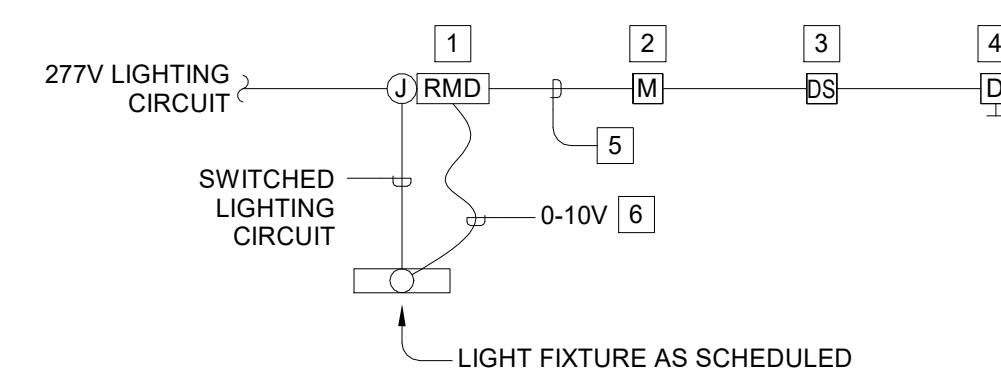

**STAND-ALONE NETWORK LIGHTING CONTROLS**  
 Not all devices shown on this wiring diagram will be used in each room, refer to plans for actual device requirements.  
 All zones automatic on, time delay 15 minutes.  
 Daylight Harvesting set point at 35 foot candles. Typical.

**3 Network Lighting Control**

SCALE: NTS

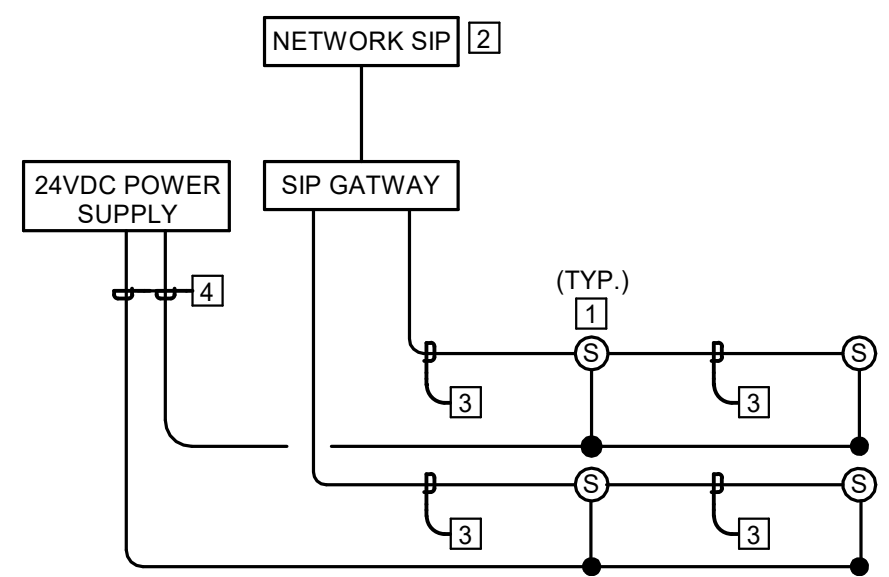

- 1 VALCOM ROUND SELF AMPLIFIED SPEAKER - V1020C, TYP. BACKBOX V-9815M, TYP.
- 2 PROVIDE VALCOM PAGEPRO VIP-201A. LOCATE IN MDF FOR OWNER TO COMPLETE FINAL CONNECTION TO SYSTEM.
- 3 PROVIDE CAT6 CABLE. ALL SPEAKERS WIRED IN PARALLEL.
- 4 PROVIDE 24VDC POWER CABLE, AS REQUIRED.

CONTRACTOR TO PROGRAM VOIP SYSTEM FOR INTERCOM.

**4 Speaker Riser Diagram**

SCALE: 12" = 1'-0"

**GENERAL SHEET NOTES**

- A. CONTRACTOR SHALL PROVIDE COMPLETE SHOP DRAWINGS FOR ALL LIGHTING CONTROLS, TO INCLUDE PRODUCT DATA SHEETS, DETAILED ROOM BY ROOM WIRING DIAGRAMS, AND COMPLETE SEQUENCE OF CONTROL OPERATIONS.
- B. WIRING DIAGRAMS HAVE BEEN PROVIDED TO CONVEY GENERAL DESIGN INTENT. PROVIDE ALL COMPONENTS, CABLING, ETC. AS REQUIRED TO PROVIDE A FULLY FUNCTIONAL SYSTEM MEETING THE DESIGN INTENT AS SHOWN ON THE PLANS.
- C. ROOM CONTROLLERS, POWER PACKS, ARE NOT NECESSARILY SHOWN ON THE PLANS. LOCATE IN AN EASILY SERVICEABLE LOCATION IN ACCESSIBLE CEILING SPACE. IF THE ROOM CEILING IS NOT ACCESSIBLE, LOCATE IN ADJACENT ROOM ACCESSIBLE CEILING SPACE AND DENOTE LOCATION ON THE RECORD DRAWINGS.
- D. 0-10V WIRING IS NOT SHOWN ON THE PLANS. PROVIDE 18-AWG SOLID COPPER WIRE RATED 600V MIN., 105°C, WITH VIOLET GRAY SHEATHING. 0-10V WIRE MAY BE ROUTED FREE AIR, CABLE TIE WIRES TO CONDUIT FOR LINE VOLTAGE WIRING.
- F. PROVIDE DIFFERENT COLOR CABLING FOR CAT5 AND CAT6 TYPE CABLES, AS TO MAKE EACH CABLE CATEGORY TYPE VISIBLY DISTINGUISHABLE.

**NUMBERED SHEET NOTES**

- 1. REMOTE DIMMING (OR SWITCHING) MODULE, NUMBER OF RELAYS CONTROLLED AS INDICATED ON THE PLANS. MAY CONSIST OF ONE DEVICE WITH MULTIPLE RELAYS, OR MORE THAN ONE SINGLE-RELAY DEVICE. DEVICE SHALL BE LOCATED CONCEALED IN AN EASILY ACCESSIBLE SPACE.
- 2. CEILING MOUNTED, DUAL TECHNOLOGY OCCUPANCY SENSOR, QUANTITY AS INDICATED ON PLANS. DEVICE SHOWN IN CORNER OF ROOM IS INTENDED TO BE A CORNER MOUNTED SENSOR.
- 3. DAYLIGHT SENSOR. FEATURE MAY BE INCORPORATED INTO A COMBINATION DEVICE (OCCUPANCY + PHOTOCELL) DEPENDING UPON MANUFACTURER, PROVIDING THAT THE PERFORMANCE OF BOTH SENSORS IS NOT COMPROMISED.
- 4. LOW VOLTAGE DIMMER SWITCH, WITH ON/OFF AND RAISE LOWER CONTROL.
- 5. NETWORK LIGHTING CONTROL CABLES PER MANUFACTURER, TYPICALLY CAT5 CABLE WITH RJ45 CONNECTORS. CAT5 CABLES TO BE DIFFERENT COLOR THAN CAT6.
- 6. 0-10V WIRING MAY BE RAN IN MC CABLE WITH POWER.



ARCH | NEXUS

Architectural NEXUS, Inc.  
 930 R Street  
 Sacramento, California 95811  
 T 916.443.5911  
 http://www.archnexus.com

Original drawings remain the property of the Architect and as such the Architect retains total ownership and control. The design represented by these drawings is sold to the client for a one time use, unless otherwise agreed upon in writing by the Architect. © Architectural Nexus, Inc. 2014

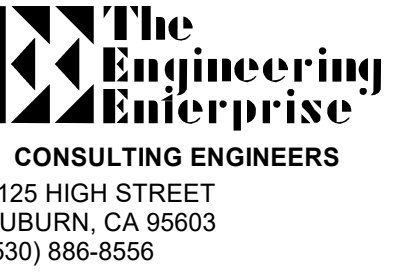

EL DORADO COUNTY  
**EDC HHS TENANT IMPROVEMENT**  
 3368 SANDY WAY  
 SOUTH LAKE TAHOE, CA 96150

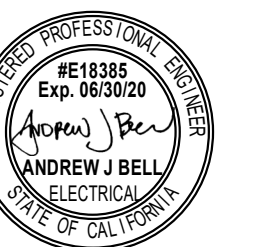

# Date Revision

**CONSTRUCTION DOCUMENTS**

NEXUS PROJ. #: 18117  
 CHECKED BY: Checker  
 DRAWN BY: Author  
 DATE: 01/02/2019

**RISER DIAGRAMS**

**E501**

18-1912 Revised B 118 of 606  
 BOS Revd 1-24-19



ARCH | NEXUS

Architectural NEXUS, Inc.  
930 R Street  
Sacramento, California 95811  
T 916.443.5911  
http://www.archnexus.com

Original drawings remain the property of the Architect and as such the Architect retains total ownership and control. The design represented by these drawings is sold to the client for a one time use, unless otherwise agreed upon in writing by the Architect.  
© Architectural Nexus, Inc. 2014

**The Engineering Enterprise**  
CONSULTING ENGINEERS  
1125 HIGH STREET  
AUBURN, CA 95603  
(930) 886-8556

EL DORADO COUNTY  
**EDC HHS TENANT IMPROVEMENT**  
3368 SANDY WAY  
SOUTH LAKE TAHOE, CA 96150

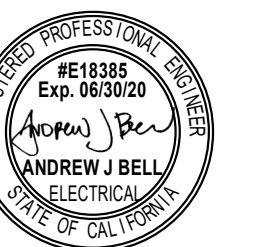

# Date Revision

**CONSTRUCTION DOCUMENTS**

NEXUS PROJ. #: 18117  
CHECKED BY: Checker  
DRAWN BY: Author  
DATE: 01/02/2019

**DETAILS**

**E600**  
18-1912 Revised B 119 of 606  
BOS Rcvd 1-24-19

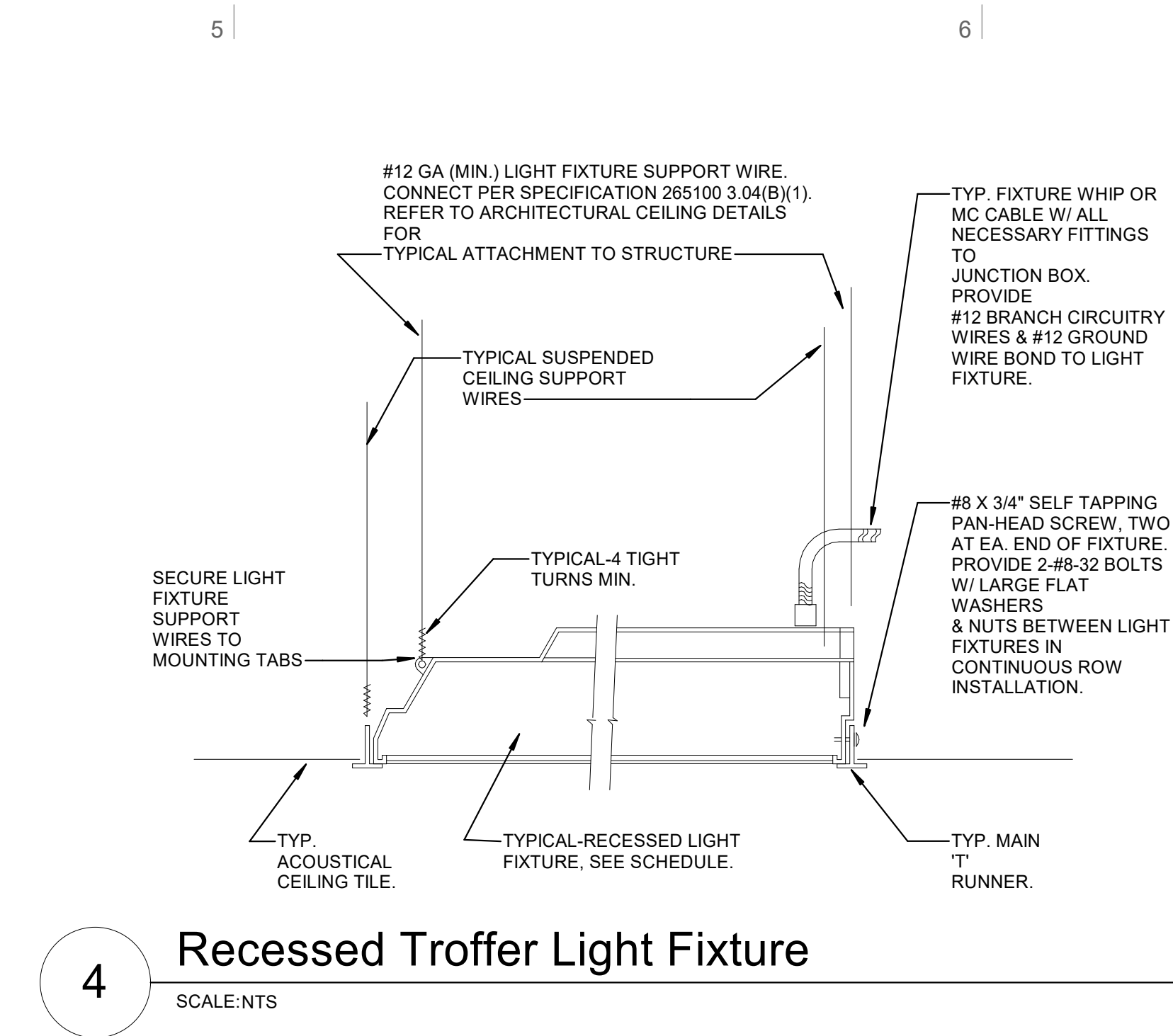

**4 Recessed Troffer Light Fixture**  
SCALE: NTS

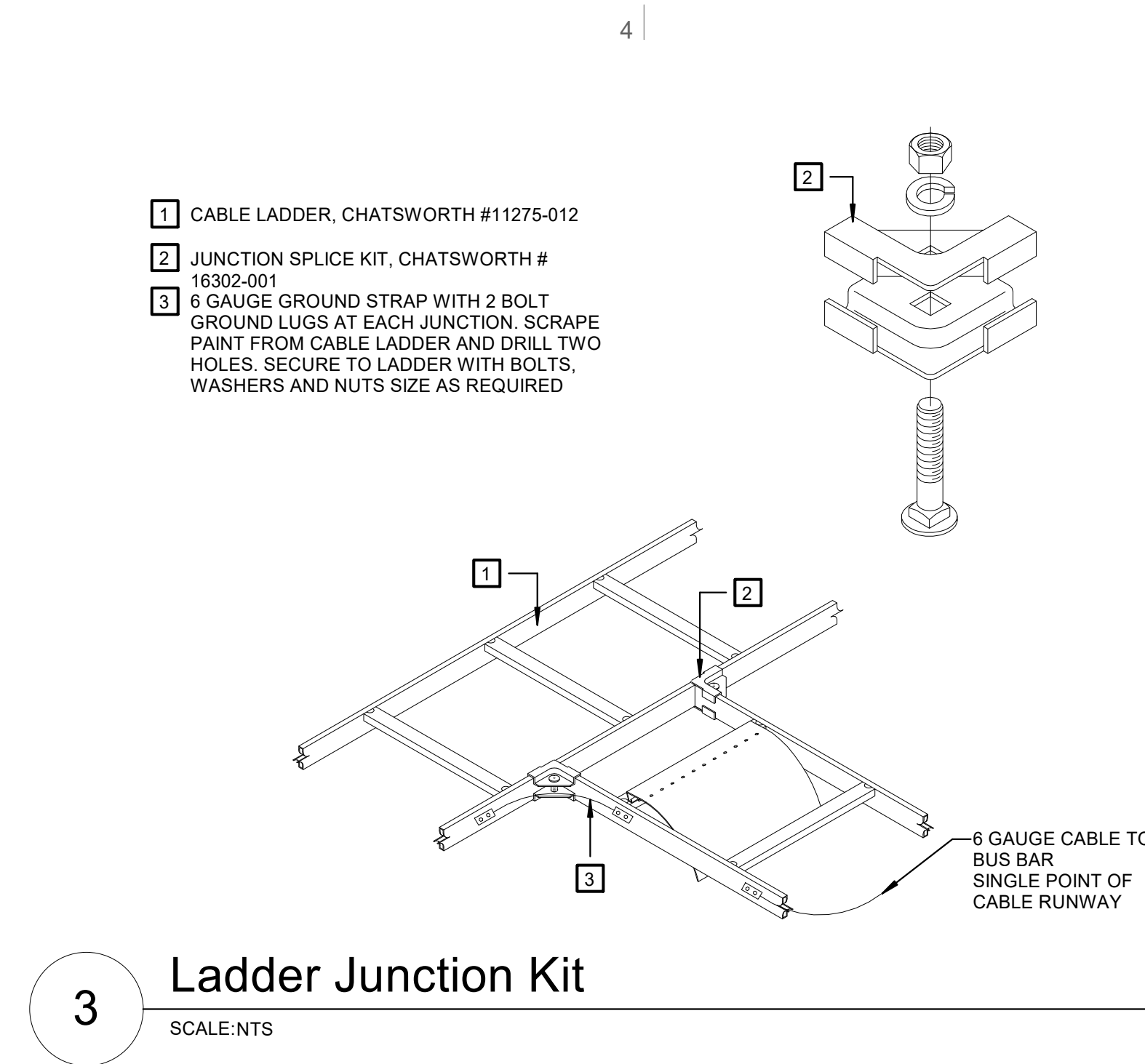

**3 Ladder Junction Kit**  
SCALE: NTS

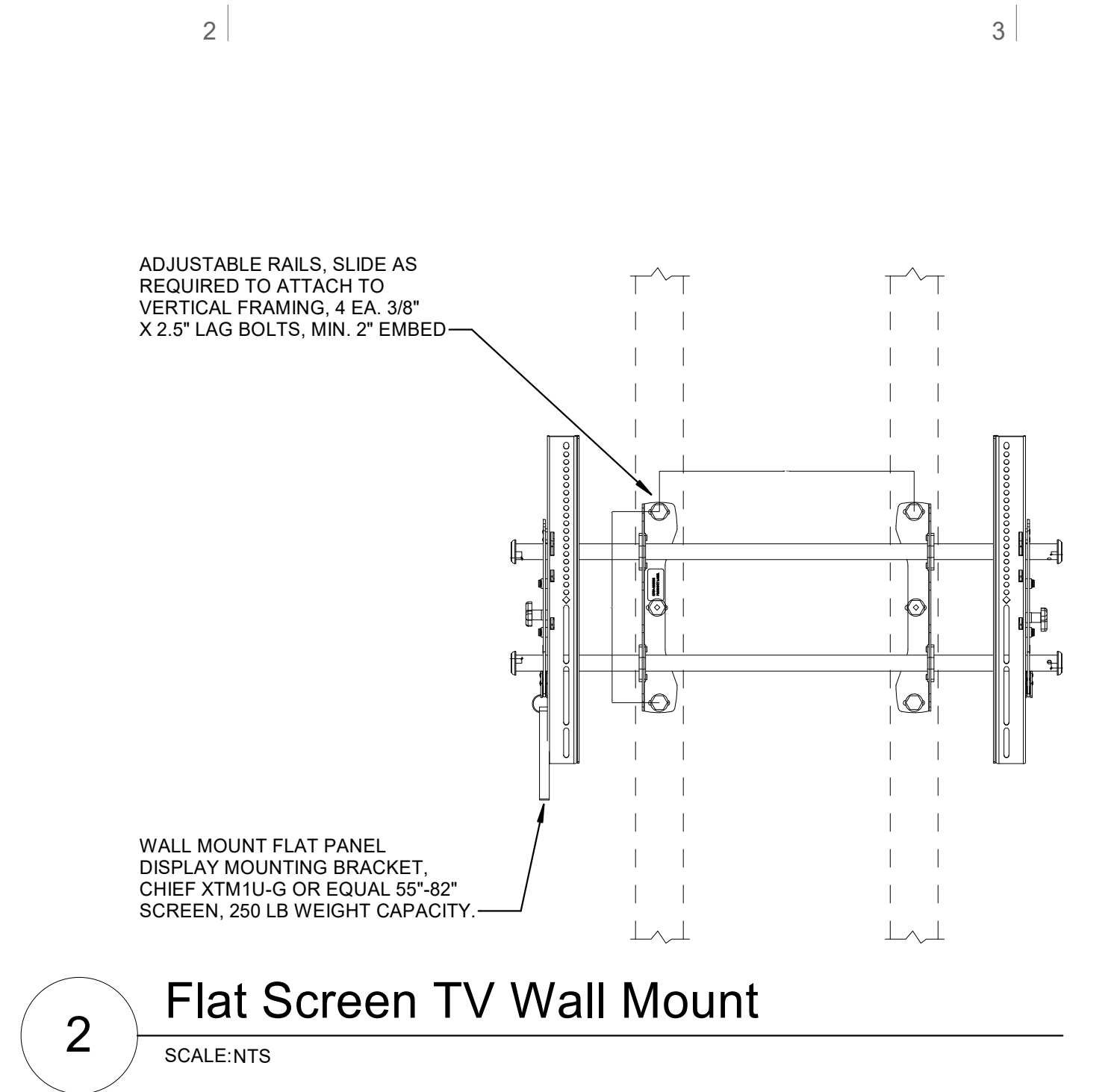

**2 Flat Screen TV Wall Mount**  
SCALE: NTS

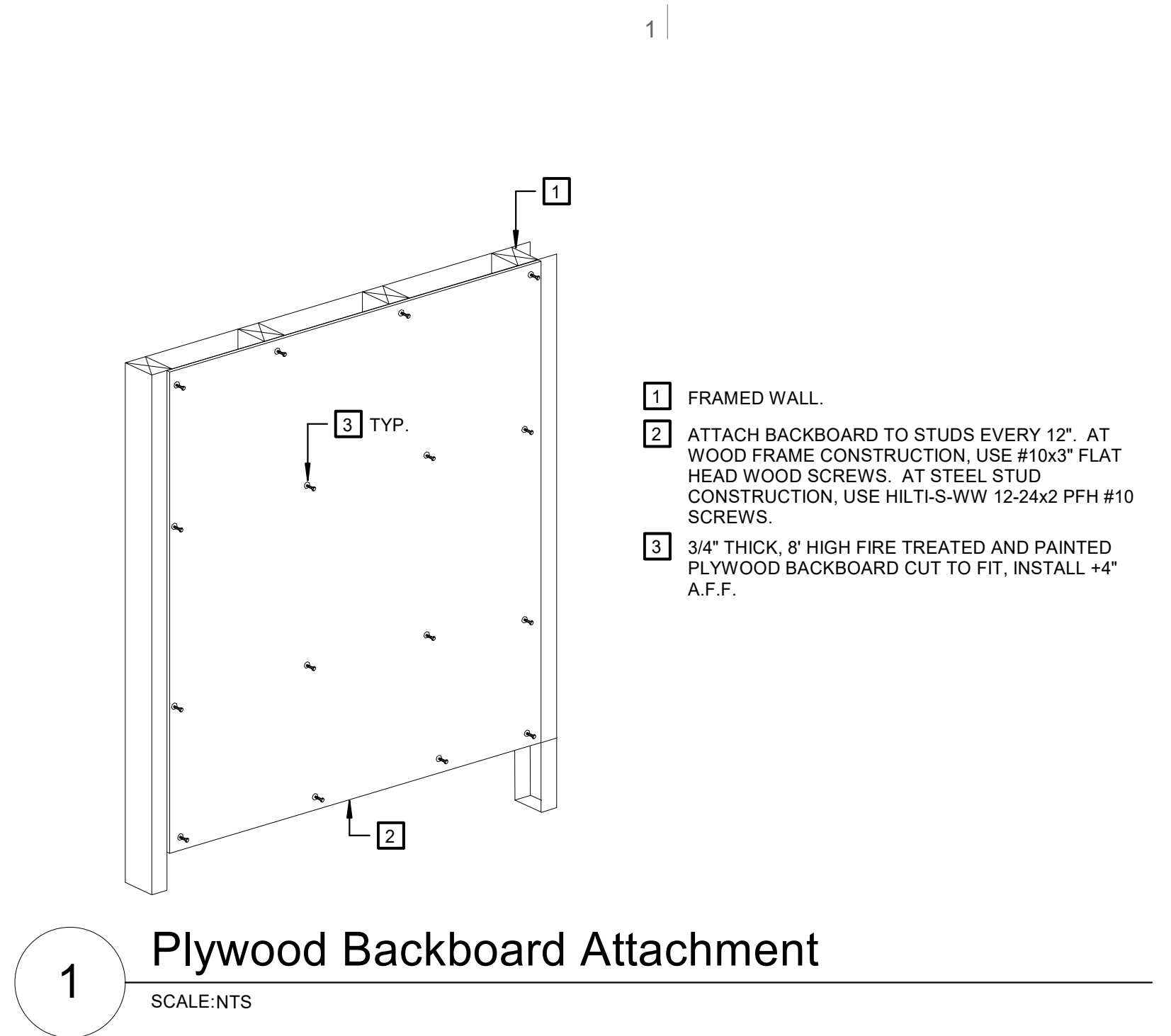

**1 Plywood Backboard Attachment**  
SCALE: NTS

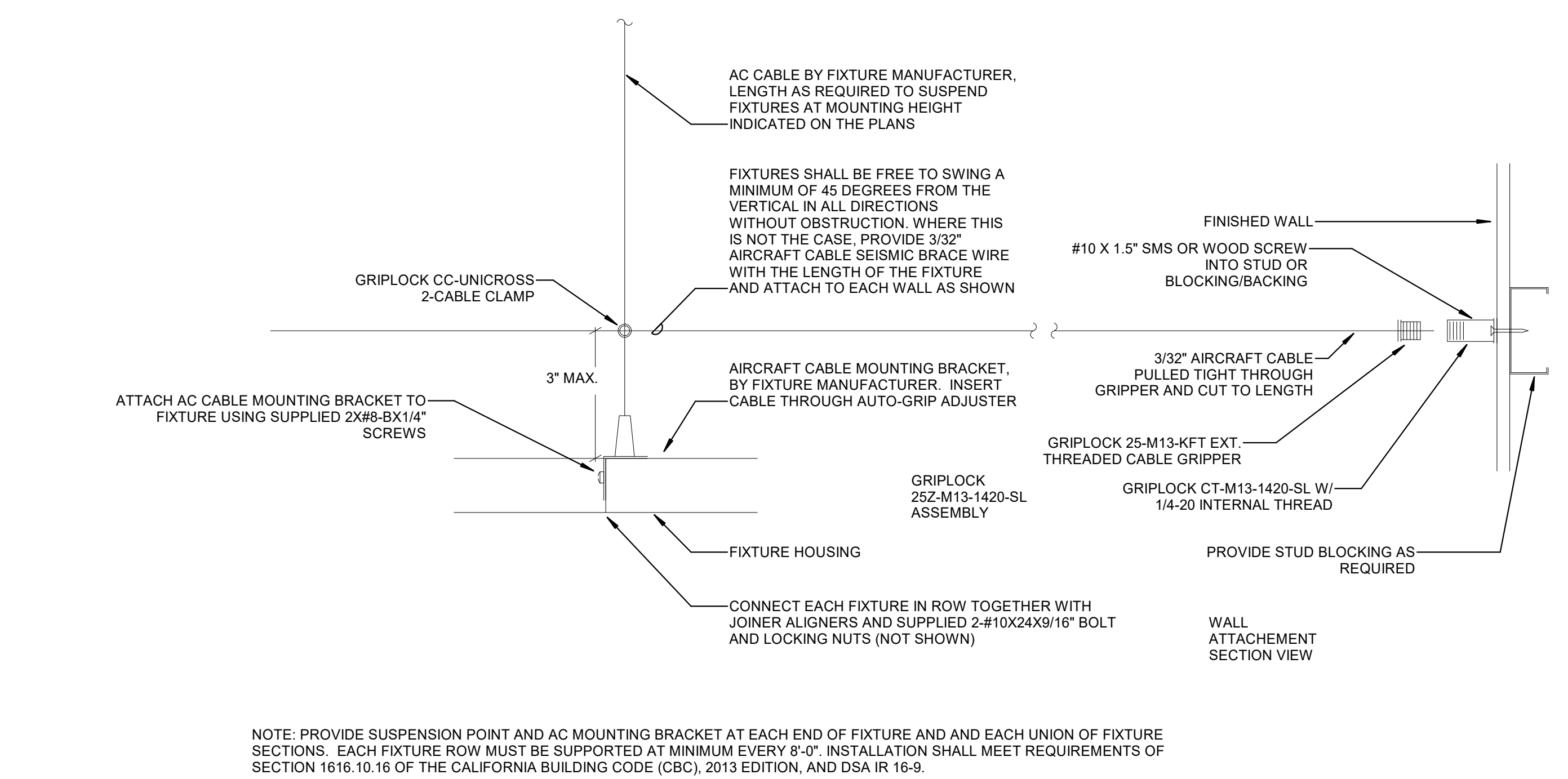

**6 Suspended Light Fixtures**  
SCALE: 1/2\" = 1'-0"

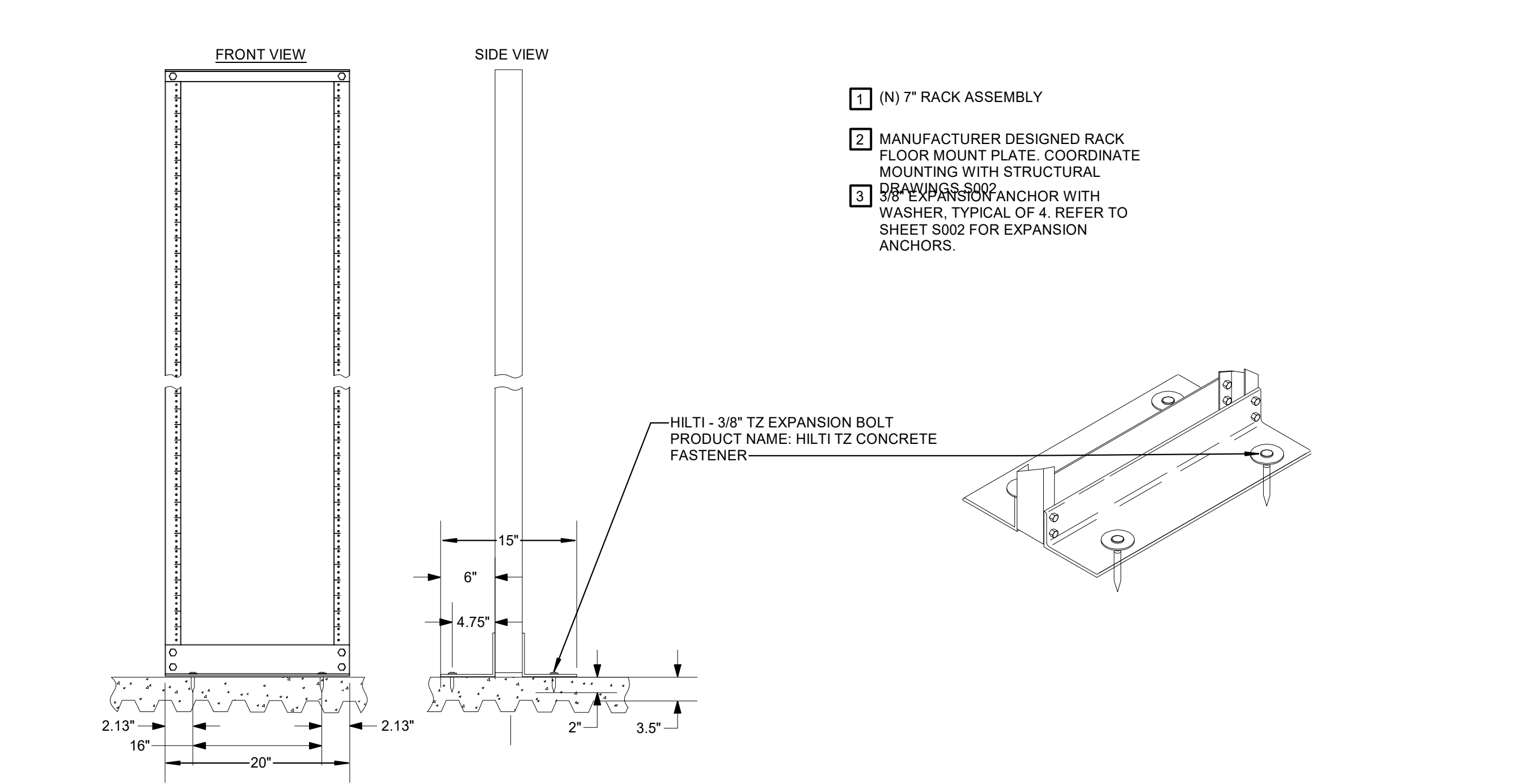

**5 Equipment Rack Base Support**  
SCALE: NTS

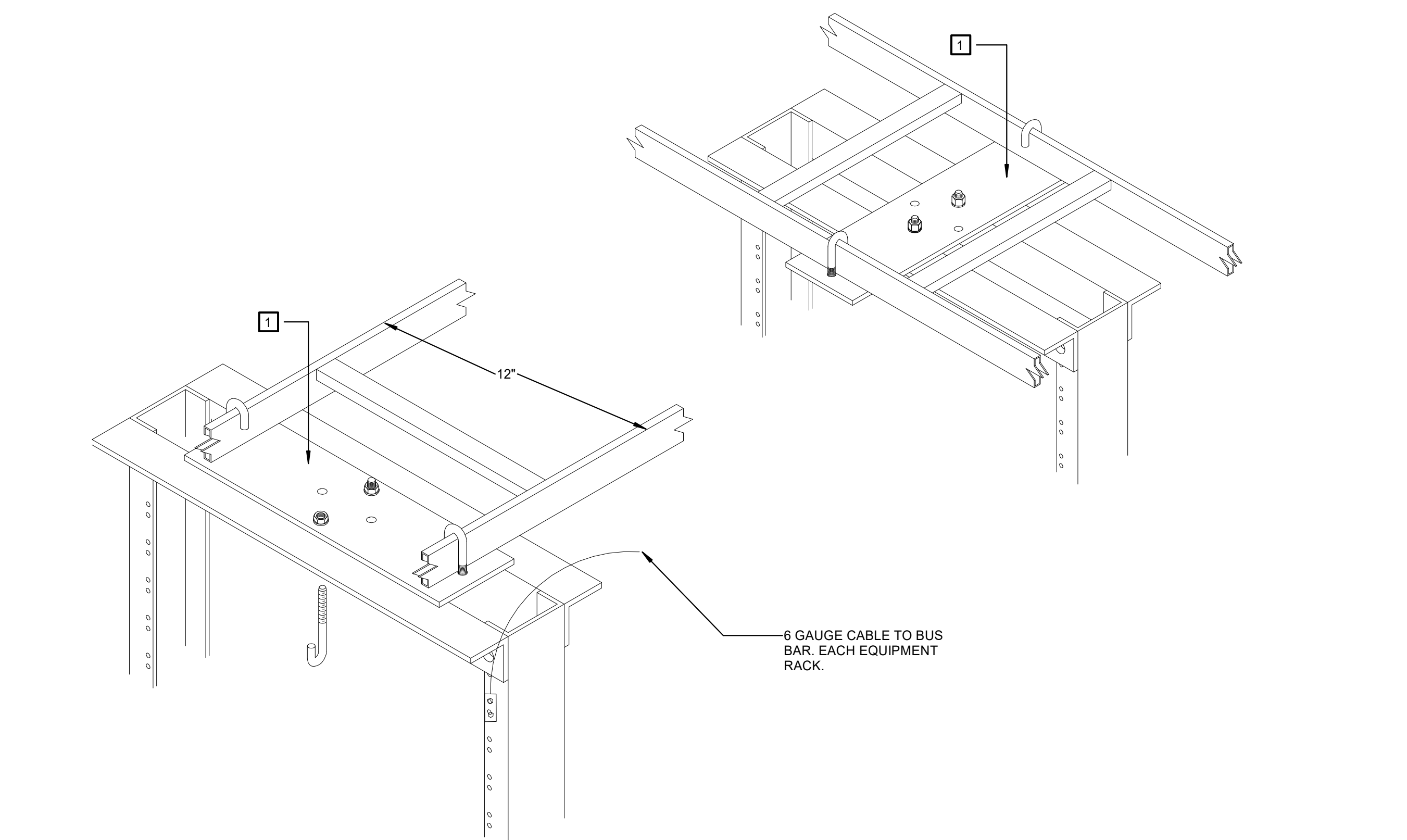

**7 Ladder to Rack Support**  
SCALE: NTS

12/26/2019 12:50:22 PM



ARCH | NEXUS

Architectural NEXUS, Inc.  
930 R Street  
Sacramento, California 95811  
T 916.443.5911  
http://www.archnexus.com

Original drawings remain the property of the Architect and as such the Architect retains total ownership and control. The design represented by these drawings is sold to the client for a one time use, unless otherwise agreed upon in writing by the Architect. © Architectural Nexus, Inc. 2014

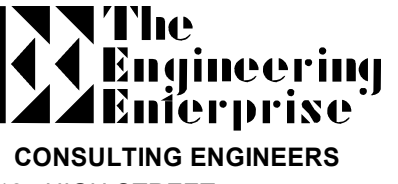

CONSULTING ENGINEERS  
1125 HIGH STREET  
AUBURN, CA 95603  
(530) 886-8556

EL DORADO COUNTY  
EDC HHS TENANT IMPROVEMENT  
3368 SANDY WAY  
SOUTH LAKE TAHOE, CA 96150

CP 617 Putty Pads, for use with max 4 by 4 in. flush device UL Listed Metallic Outlet Boxes installed with steel cover plates in 1 and 2 hr. fire rated gypsum wallboard wall assemblies framed with min 3-1/2 in. deep wood or steel studs and constructed as specified in the individual U300 or U400 Series Wall and Partition Designs in the Fire Resistance Directory. Min 1/8 in. thick moldable putty pads are to be installed to completely cover the exterior surfaces of the outlet box (except for the side of the outlet box against the stud) and completely seal against the stud within the stud cavity. When moldable putty pad outlet box protective material is used on boxes on both sides of wall as directed, the horizontal separation between outlet boxes on opposite sides of the wall may be less than 24 in. provided that the boxes are not installed back to back.

CP 617 Firestop Putty Pads, for use with max 4-11/16 by 4-11/16 in. flush device UL Listed Metallic Outlet Boxes installed with steel cover plates for use in 1 hr fire rated configuration of Wall and Partition Design No. V446 in the Fire Resistance Directory. Min 1/8 in. thick moldable putty pads are to be installed to completely cover the exterior surfaces of the outlet box (except for the side of the outlet box against the stud) and to completely seal against the box within the stud cavity. When moldable putty pad outlet box protective material is used on boxes on both sides of wall as directed, the horizontal separation between outlet boxes on opposite sides of the wall may be less than 24 in. and the boxes may be installed back to back.

CP 617 Firestop Putty Pads, for use with max 4 by 3-3/4 by 3 in. deep UL Listed Nonmetallic Outlet Boxes manufactured by Carlon Electrical Products, made from polyvinyl chloride, and bearing a 2 hr rating under the "Outlet Boxes and Fittings Classification for Fire Resistance" category in the Fire Resistance Directory. Putty pads and boxes for use in 1 and 2 hr fire rated gypsum wallboard assemblies, framed with min 3-1/2 in. deep wood studs and constructed as specified in the individual U300 Series Wall and Partition Designs in the Fire Resistance Directory. Outlet box secured to wood stud by means of two nailing tabs supplied with the outlet box. Min 1/8 in. thick moldable putty pads are to be installed to completely cover the exterior surfaces of the outlet box (except for the sides of the outlet box against the stud) including the nailing tab and completely seal against the stud within the stud cavity. Outlet boxes installed with steel or plastic cover plates. When moldable putty pad outlet box protective material is used on boxes on both sides of wall as directed, the horizontal separation between boxes on opposite sides of the wall may be less than 24 in. provided that the boxes are not installed back to back.

CP 617 Putty Pads, for use with max 4 by 4 by 2-7/8 in. deep UL Listed Nonmetallic Outlet Boxes manufactured by Carlon Electrical Products, made from polyvinyl chloride, and bearing a 2 hr rating under the "Outlet Boxes and Fittings Classification for Fire Resistance" category in the Fire Resistance Directory. Putty pads and boxes for use in 1 and 2 hr fire rated V446 gypsum board/steel stud Wall and Partition Design in the Fire Resistance Directory. Outlet box secured to steel stud by means of fastening tab supplied with the outlet box. Min 1/8" thick moldable putty pads are to be installed to completely cover the exterior surfaces of the outlet box (except for the side of the outlet box against the stud) including the tab and completely seal against the stud within the stud cavity. Outlet boxes installed with steel or plastic cover plates. When moldable putty pad outlet box protective material is used on boxes on both sides of wall as directed, the horizontal separation between boxes on opposite sides of the wall may be less than 24 in. and the boxes may be installed back to back.

CP 617 Firestop Putty Pads, for use with max 2-1/4 by 3-3/4 by 3-3/4 in. deep UL Listed Nonmetallic Outlet Boxes manufactured by Pass and Seymour, Inc., and bearing a 2 hr rating under the "Outlet Boxes and Fittings Classification for Fire Resistance" category in the Fire Resistance Directory. Putty pads and boxes for use in 1 and 2 hr fire rated gypsum wallboard assemblies, framed with min 3-1/2 in. deep wood studs and constructed as specified in the individual U300 Series Wall and Partition Designs in the Fire Resistance Directory. Outlet box secured to wood stud by means of two nailing tabs supplied with the outlet box. Min 1/8 in. thick moldable putty pads are to be installed to completely cover the exterior surfaces of the outlet box (except for the sides of the outlet box against the stud) including the nailing tab and completely seal against the stud within the stud cavity. Outlet boxes installed with steel or plastic cover plates. When moldable putty pad outlet box protective material is used on boxes on both sides of wall as directed, the horizontal separation between boxes on opposite sides of the wall may be less than 24 in. provided that the boxes are not installed back to back.

CP 617 Firestop Putty Pads, for use with max 4 by 3-3/4 by 3 in. deep UL Listed Nonmetallic Outlet Boxes manufactured by Allied Molded Products, Inc., made from fiber reinforced thermoplastic and bearing a 2 hr rating under the "Outlet Boxes and Fittings Classification for Fire Resistance" category in the Fire Resistance Directory. Putty pads and boxes for use in 1 hr fire rated gypsum wallboard assemblies, framed with min 3-1/2 in. deep wood studs and constructed as specified in the individual U300 Series Wall and Partition Designs in the Fire Resistance Directory. Outlet box secured to wood stud by means of two nailing tabs supplied with the outlet box. Min 1/8 in. thick moldable putty pads are to be installed to completely cover the exterior surfaces of the outlet box (except for the sides of the outlet box against the stud) including the nailing tabs and completely seal against the stud within the stud cavity. Outlet boxes installed with plastic cover plates. When moldable putty pad outlet box protective material is used on boxes on both sides of wall as directed, the horizontal separation between boxes on opposite sides of the wall may be less than 24 in. provided that the boxes are not installed back to back.

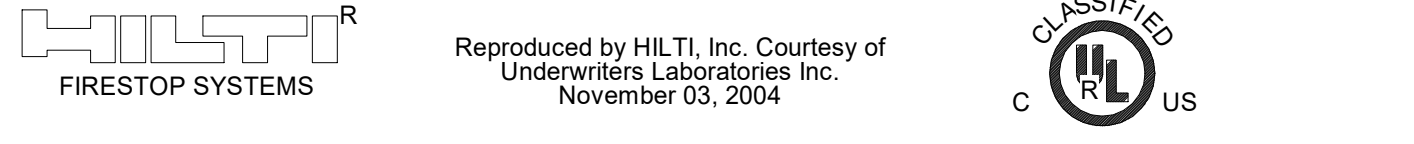

GENERAL SHEET NOTES  
A. REFER TO ARCHITECTURAL PLANS FOR IDENTIFICATION OF ALL RATED WALL ASSEMBLIES.  
ALL CONDUIT AND BOX PENETRATIONS OF RATED WALLS SHALL BE INSTALLED PER THE APPLICABLE UL LISTED ASSEMBLY.

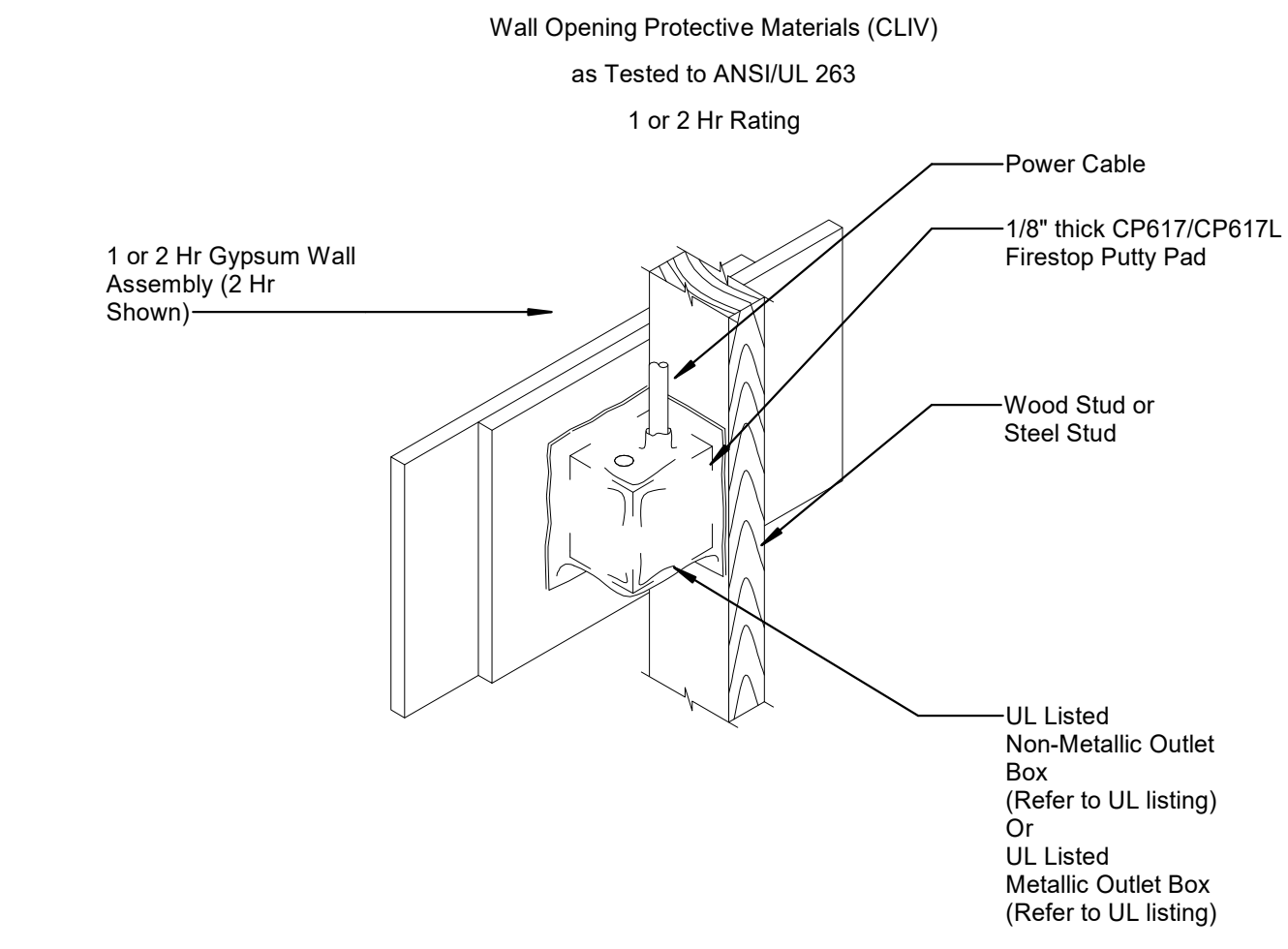

1 Rated Penetration Detail  
SCALE: NTS

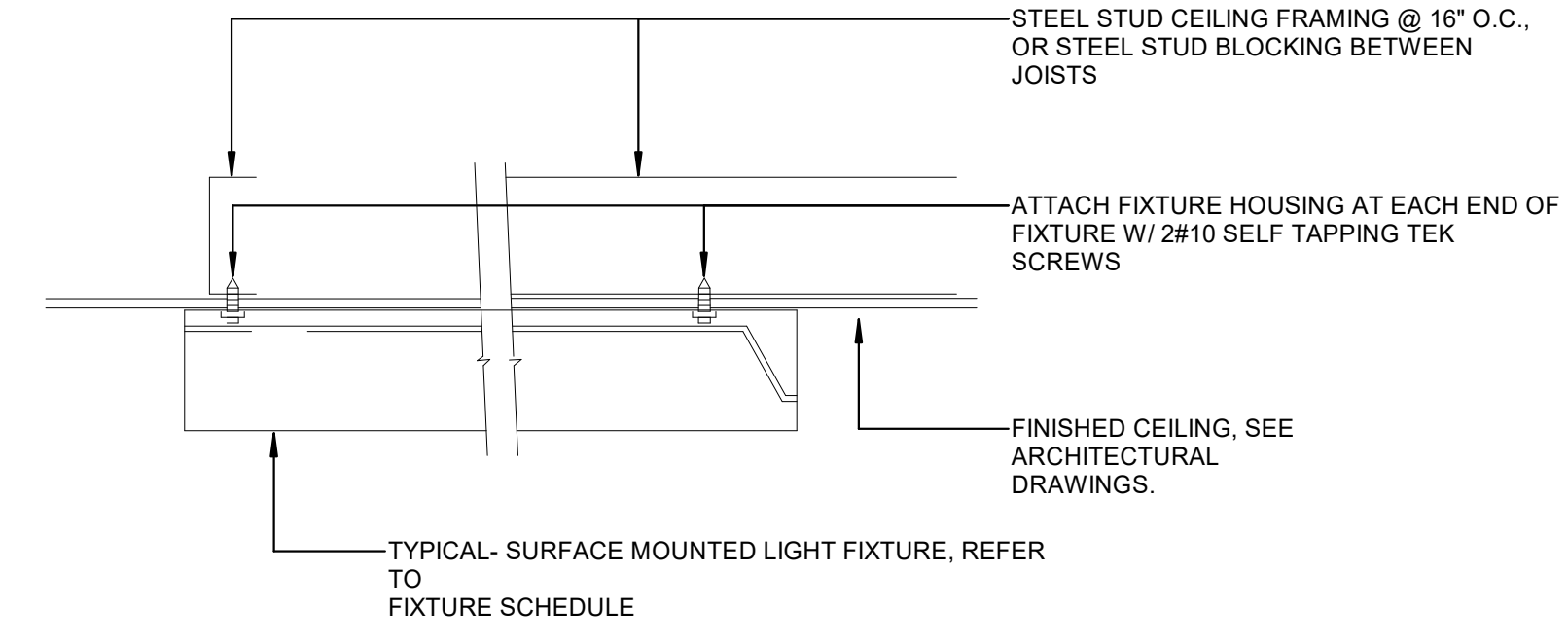

2 Surface Mounted Fixture  
SCALE: NTS

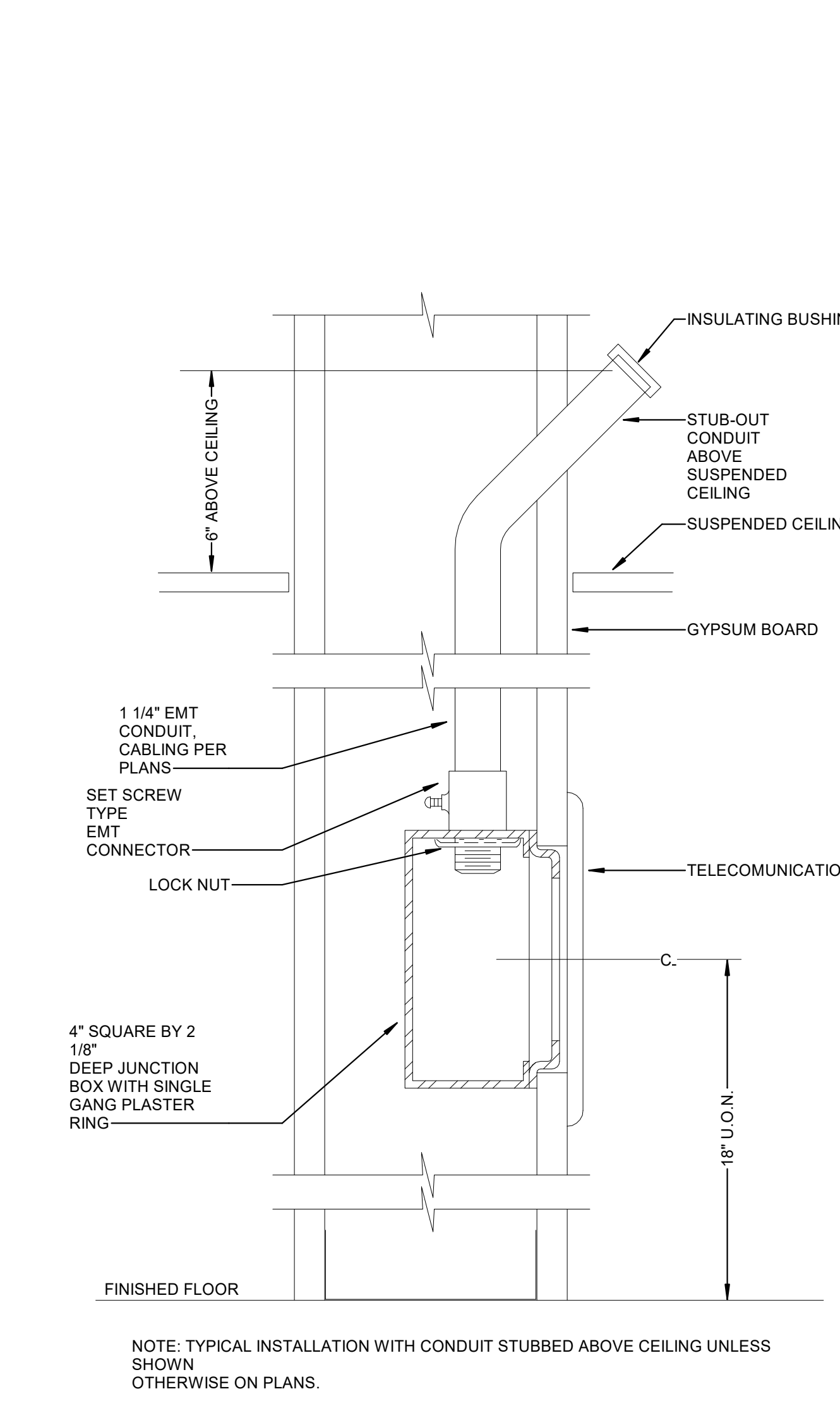

3 Low Voltage Device - Fire Rated Or Insulated Wall Locations  
SCALE: NTS

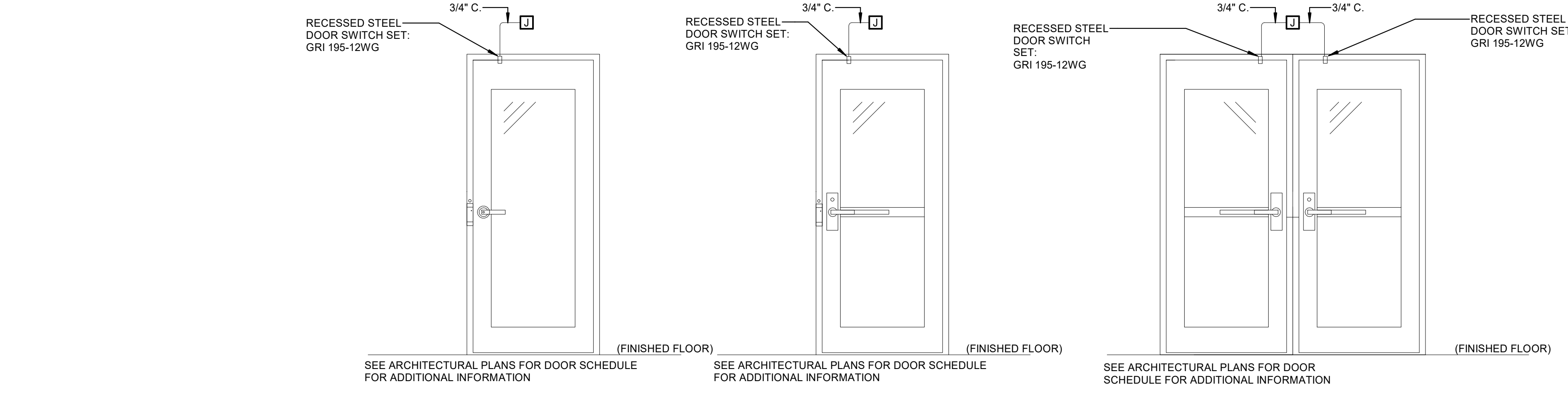

5 Typical Door Elevations-Access and Intrusions  
SCALE: NTS

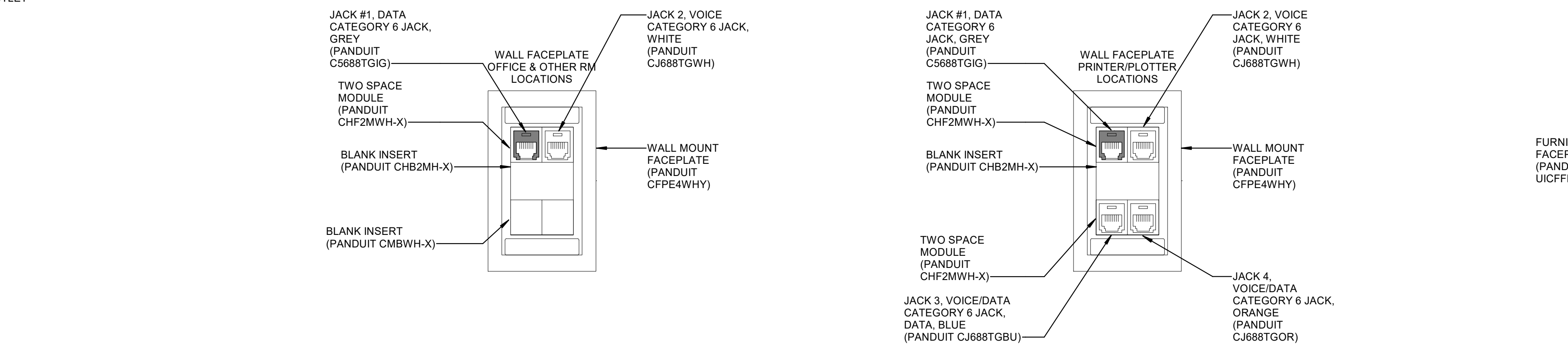

4 Typical Wall Cable Termination Plate  
SCALE: NTS

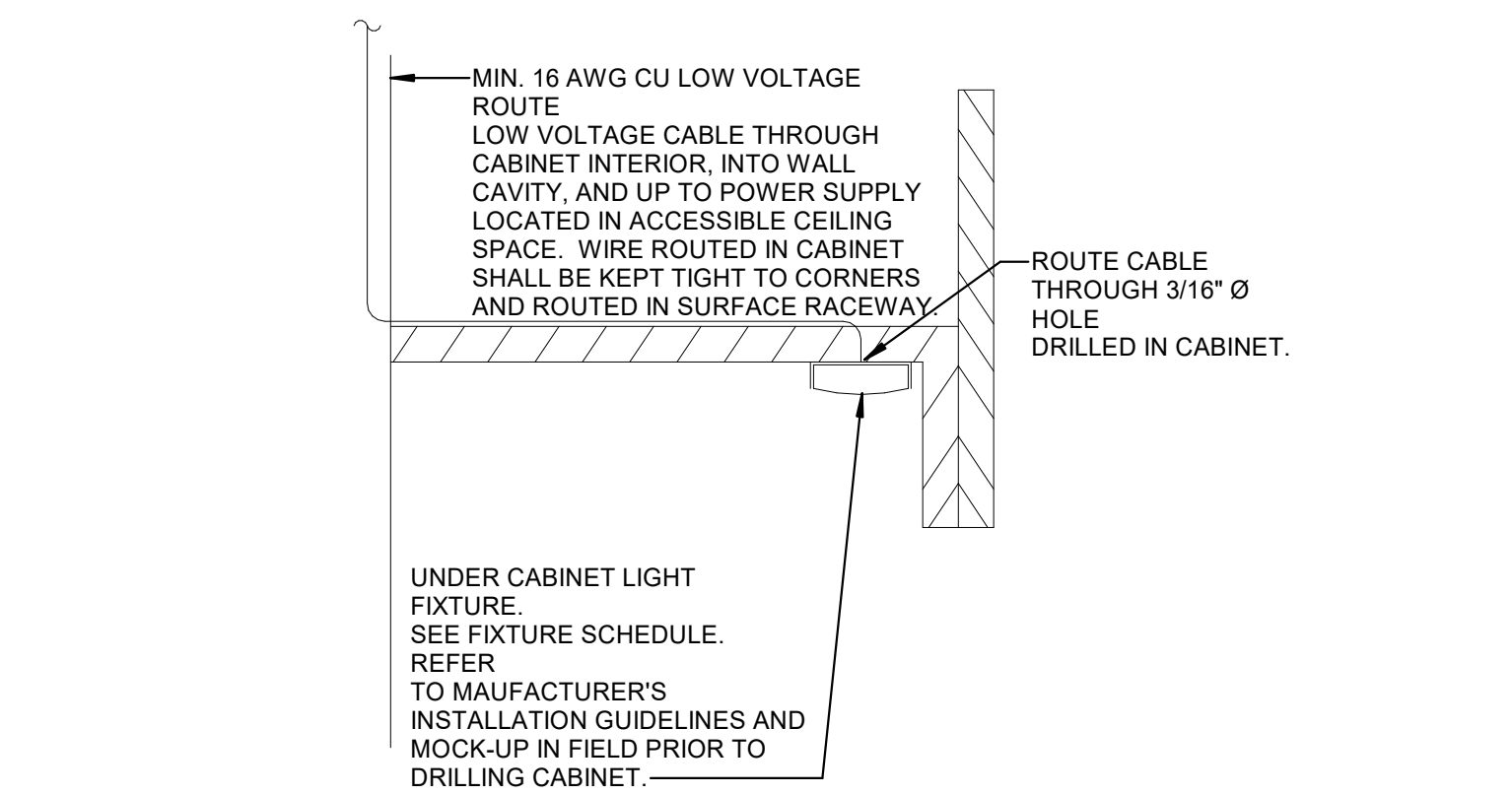

6 Undercabinet Light Fixture  
SCALE: NTS

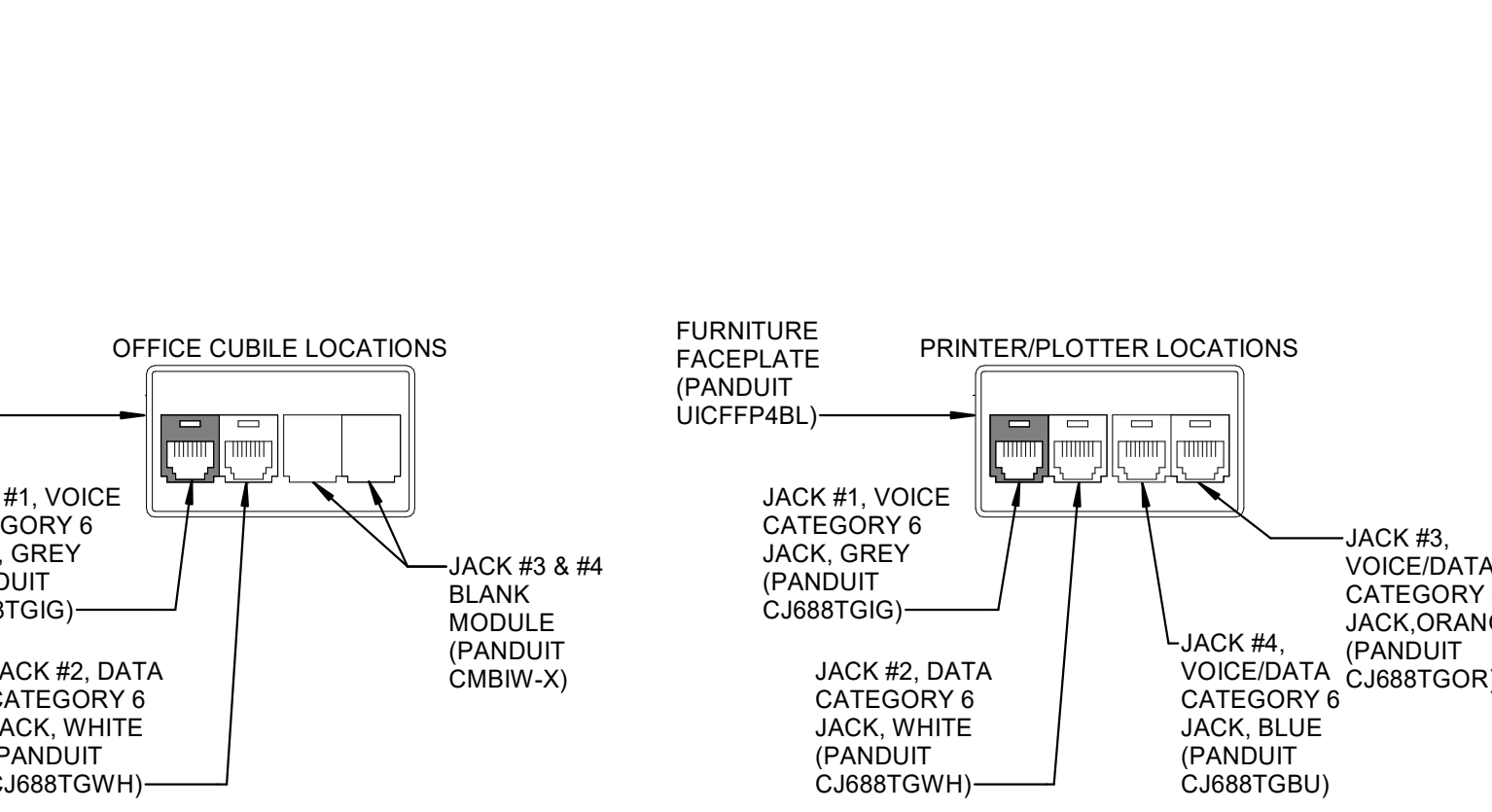

7 Typical Furniture Cable Termination Plate  
SCALE: NTS

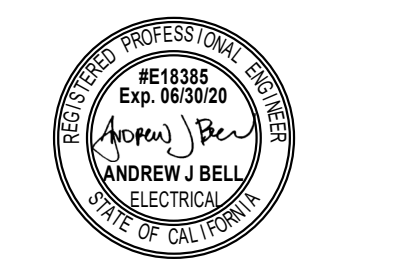

# Date Revision

CONSTRUCTION DOCUMENTS

NEXUS PROJ. #: 18117  
CHECKED BY: Author  
DRAWN BY: Andrew J. Bell  
DATE: 01/02/2019

DETAILS



EXHIBIT C

# PROJECT MANUAL

## County of El Dorado HHSA TENANT IMPROVEMENT

3368 Sandy Way, South Lake Tahoe, CA

Arch Nexus Project # 18117.00

**Prepared For:**

EL DORADO COUNTY  
3000 FAIRLANE COURT  
SUITE 1  
PLACERVILLE, CALIFORNIA  
95667

**Prepared By:**

ARCHITECTURAL NEXUS  
930 R STREET  
SACRAMENTO, CALIFORNIA  
95811

**Project Team:**

MIYAMOTO INTERNATIONAL  
CAPITAL ENGINEERING  
CONSULTANTS, INC.  
THE ENGINEERING  
ENTERPRISE

# TABLE OF CONTENTS

## COVER & TABLE OF CONTENTS

00 01 01 PROJECT TITLE PAGE 1  
00 01 10 TABLE OF CONTENTS

## DIVISION 00 — PROCUREMENT AND CONTRACTING REQUIREMENTS

## DIVISION 01 — GENERAL REQUIREMENTS

011000 - SUMMARY  
012300 - ALTERNATES  
012500 - SUBSTITUTION PROCEDURES  
013300 - SUBMITTAL PROCEDURES  
015000 - TEMPORARY FACILITIES AND CONTROLS  
017300 - EXECUTION  
017419 - CONSTRUCTION WASTE MANAGEMENT AND DISPOSAL  
017700 - CLOSEOUT PROCEDURES  
017823 - OPERATION AND MAINTENANCE DATA  
017839 - PROJECT RECORD DOCUMENTS  
017900 - DEMONSTRATION AND TRAINING

## DIVISION 02 — EXISTING CONDITIONS

024119 - SELECTIVE DEMOLITION

## DIVISION 03 — CONCRETE

033000 - CAST-IN-PLACE CONCRETE

## DIVISION 05 — METALS

055000 - METAL FABRICATIONS

## DIVISION 06 — WOOD, PLASTICS, AND COMPOSITES

061000 - ROUGH CARPENTRY  
062013 - EXTERIOR FINISH CARPENTRY

## DIVISION 07 — THERMAL AND MOISTURE PROTECTION

072100 - THERMAL INSULATION  
072500 - WEATHER BARRIERS  
075113 - BUILT-UP ASPHALT ROOFING

076200 - SHEET METAL FLASHING AND TRIM  
07 72 00 - ROOF ACCESSORIES  
079200 - JOINT SEALANTS

**DIVISION 08 — OPENINGS**

081113 - HOLLOW METAL DOORS AND FRAMES  
081416 - FLUSH WOOD DOORS  
083113 - ACCESS DOORS AND FRAMES  
084113 - ALUMINUM-FRAMED ENTRANCES AND STOREFRONTS  
085113 - ALUMINUM WINDOWS  
08 71 00 - DOOR HARDWARE  
088000 - GLAZING

**DIVISION 09 — FINISHES**

092900 - GYPSUM BOARD  
095113 - ACOUSTICAL PANEL CEILINGS  
096513 - RESILIENT BASE AND ACCESSORIES  
096516 - RESILIENT SHEET FLOORING  
096813 - TILE CARPETING  
09 77 00 - FIBERGLASS REINFORCED PANELING  
097710 - FIBER REINFORCED LAMINATES  
099000 - PAINTING AND COATING

**DIVISION 10 — SPECIALTIES**

10 14 23 - PANEL SIGNAGE  
10 21 13 - PLASTIC TOILET COMPARTMENTS  
102800 - TOILET BATH AND LAUNDRY ACCESSORIES  
104416 - FIRE EXTINGUISHERS

**DIVISION 12 — FURNISHINGS**

123216 - MANUFACTURED PLASTIC-LAMINATE-FACED CASEWORK  
12 36 23 - PLASTIC-LAMINATE-CLAD COUNTERTOPS  
123661.16 - SOLID SURFACING COUNTERTOPS

**DIVISION 22 — PLUMBING**

22 00 50 - BASIC PLUMBING MATERIALS AND METHODS  
22 40 00 - PLUMBING FIXTURES  
22 50 00 - PLUMBING EQUIPMENT

**DIVISION 23 — HEATING VENTILATING AND AIR CONDITIONING**

23 00 50 - BASIC HVAC MATERIALS AND METHODS  
23 05 93 - TESTING, ADJUSTING, AND BALANCING FOR HVAC  
23 80 00 - HEATING, VENTILATING AND AIR CONDITIONING

**DIVISION 26 — ELECTRICAL**

26 00 10 - BASIC ELECTRICAL REQUIREMENTS  
26 00 90 - ELECTRICAL DEMOLITION  
26 05 19 - BUILDING WIRE AND CABLE  
26 05 26 - GROUNDING AND BONDING  
26 05 29 - ELECTRICAL HANGERS AND SUPPORTS  
26 05 31 - CONDUIT  
26 05 33 - BOXES  
26 05 53 - ELECTRICAL IDENTIFICATION  
26 09 26 - LOW-VOLTAGE LIGHTING CONTROL  
26 24 16 - PANELBOARDS  
26 27 26 - WIRING DEVICES  
26 28 16 - OVERCURRENT PROTECTIVE DEVICES  
26 28 19 - DISCONNECT SWITCHES

26 50 00 - LIGHTING  
26 61 13 - FIRE ALARM SYSTEM

**DIVISION 27 — COMMUNICATIONS**

27 00 10 - BASIC COMMUNICATION REQUIREMENTS  
27 05 29 - COMMUNICATIONS HANGERS AND SUPPORTS  
27 05 53 - COMMUNICATIONS IDENTIFICATION  
27 11 00 - COMMUNICATIONS EQUIPMENT ROOMS  
27 15 00 - COMMUNICATIONS HORIZONTAL CABLING  
27 51 23 - PUBLIC ADDRESS INTERCOM SYSTEM

## SECTION 01 1000 - SUMMARY

### PART 1 - GENERAL

#### 1.1 SUMMARY

- A. Section Includes:
  - 1. Project information.
  - 2. Work covered by Contract Documents.
  - 3. Phased construction.
  - 4. Work under separate contracts.
  - 5. Access to site.
  - 6. Coordination with occupants.
  - 7. Work restrictions.
  - 8. Specification and Drawing conventions.

#### 1.2 PROJECT INFORMATION

- A. Project Identification: EDC HHSA Tenant Improvement.
  - 1. Project Location: 3368 Sandy Way, South Lake Tahoe, CA 96150.
- B. Owner: El Dorado County.
  - 1. Owner's Representative: Charles Harrell.
- C. Architect: Architectural Nexus, 930 R Street, Sacramento, CA 95811.

#### 1.3 WORK COVERED BY CONTRACT DOCUMENTS

- A. The Work of Project is defined by the Contract Documents and consists of the following:
  - 1. Tenant Improvement to existing County-owned commercial single story wood frame building. Scope includes minor interior demolition and remodel for office occupancy, enclosing covered loading dock for new office space, replacing rooftop HVAC units, new interior mechanical, plumbing and electrical systems, low voltage, data, voice, access control systems, intrusion alarm system and new fire alarm system. A new roof access ladder and new roof hatch will be provided. No structural work is anticipated.
- B. Type of Contract:
  - 1. Project will be constructed under a single prime contract.

#### 1.4 ACCESS TO SITE

- A. General: Contractor shall have full use of the building for construction operations during construction period. Contractor's parking is limited to the south parking lot. The North parking lot off Sandy Way is for Owner use only. The Contractor can access all sides and entrances of the building. The Owner reserves the right to perform work or to retain other contractors on portions of Project.

1.5 WORK RESTRICTIONS

- A. Work Restrictions, General: Comply with restrictions on construction operations.
  - 1. Comply with limitations on use of public streets and with other requirements of authorities having jurisdiction.
- B. On-Site Work Hours: Limit work in the existing building to normal business working hours of 7:00 a.m. to 5:00 p.m., Monday through Friday, unless otherwise indicated or authorized by the County.
- C. Nonsmoking Building: Smoking or the use of tobacco products is not permitted within the contract limit.
- D. Restricted Substances: Use of tobacco products and other controlled substances on Project site is not permitted.

1.6 PERMITS AND FEES

- A. County's responsibility:
  - 1. The Architect will provide signed documents for the County to submit for agency review. The County will pay the following costs to be paid directly to the governing agency and entity upon request from the contractor:
    - a. Plan check fees (completed prior to bidding).
    - b. Building Permits.
    - c. Impact Fees
    - d. Conditions Use Permit Fee (i.e. – gas, sewer, water, power, phone)
    - e. Utility unit labor and material costs for work not included with connection fees and normally performed by the utility company.
    - f. Testing
- B. Contractors responsibility:
  - 1. The contractor will make arrangements to secure permits as necessary and will notify the County's project representative, in a timely manner, of the fee amount required to obtain the required permit. The contractor will be responsible for notifying the County Project Manager, in a timely manner of all costs to be paid by the County.
  - 2. The contractor will be responsible for all bonding requirements.
  - 3. The contractor will be responsible for any delegated design or deferred submittals, including the permit process. The County will compensate the contractor for the initial plan check process and permit fees only. Any additional plan reviews will be at the cost of the contractor.

1.7 SPECIFICATION AND DRAWING CONVENTIONS

- A. Specification Content: The Specifications use certain conventions for the style of language and the intended meaning of certain terms, words, and phrases when used in particular situations. These conventions are as follows:
  - 1. Imperative mood and streamlined language are generally used in the Specifications. The words "shall," "shall be," or "shall comply with," depending on the context, are implied where a colon (:) is used within a sentence or phrase.

2. Specification requirements are to be performed by Contractor unless specifically stated otherwise.

B. Division 01 General Requirements: Requirements of Sections in Division 01 apply to the Work of all Sections in the Specifications.

#### 1.8 SPECIAL INSPECTIONS AND TESTING

A. The contractor will be responsible for coordinating and scheduling all inspections and disseminating all required reports to the proper parties.

A. All retesting for previously failed tests shall be paid for by the contractor.

#### 1.9 CHANGES IN THE WORK

A. Any changes in the work of this contract due to discovered conditions or project scope modifications are subject to the following requirements:

1. A "Request for Proposal" shall be issued to the Contractor by the Architect clearly stating the exact conditions of the proposed change in the work or a "Request for Change" shall be issued to the Architect by the Contractor for review and acceptance.

2. The Contractor shall provide a written "Proposal" identifying the specific material and labor required to complete the change in the work. The Proposal shall completely itemize all material quantities, unit costs, labor estimates, hourly rates, and mark-up factors calculated in the overall cost. Material costs shall not exceed those listed at established market levels and labor costs shall not exceed those listed at Journeyman schedules as established for this region by current year R.S.Means.

a. Direct subcontractor and/or contractor mark-up for profit, overhead and administrative costs shall not exceed a combined total of 15% of the itemized costs for material supplied and labor directly performed by that individual firm. Additional contractor mark-up on subcontractor work is limited to 5% of the work of those other subcontractor amount. A maximum additional performance bond mark-up of 1%, or the actual bond cost rate as verified by the bonding company, will also be allowed as valid mark-up as part of the Contractor's submittals.

b. No other mark-ups are allowed. (i.e. project management, supervision)

3. The County shall review and certify all Contractor's proposals if there is reasonable justification for the proposed change.

4. Execution of formal change orders is a time consuming process which could delay action on critical work. Any work performed prior to the issuance of the official change order is at the contractor's risk. However, the County Project Manager will endeavor to minimize that risk through the expeditious processing of all change order items. Full, complete and detailed information on each item by the contractor will aide in that process.

5. Change Authorizations: A construction change authorization form will be issued by the County under special circumstances, to authorize immediate completion of changes in the work. The form will be prepared and completed by the Architect when time limits are such that the formal change order will cause unreasonable delays or additional costs to the project. The form will include a fixed or estimated cost to be included as part of a change order at the earliest possible date. All forms should be numbered consecutively, beginning with number one of each project. Electronic format shall be used. The

Architect shall maintain a log for construction change authorizations throughout the entire construction phase.

#### 1.10 PRODUCT APPROVALS

- A. The intent of the product specifications and substitution process is not to exclude the use of other brands, articles or methods which may be acceptable and deserving of consideration. However, the County and the Architect must approve any product or material substitution prior to purchase or installation. Substitution requests are to be submitted immediately after bid opening for consideration. See **012500 Substitution Procedures** for more detailed instructions. In general:
1. Submit fully detailed technical data, samples, installation methods, test reports and certification, references and all other supporting documentation as may be requested by the Architect.
  2. Prove to the Architect and the County that items held up as equal or superior to specified items meet project specification design and intent. Obtaining prior approval does not relieve the contractor from meeting the project specifications or any portion thereof.

#### 1.11 SCHEDULE OF VALUES / LIST OF SUBCONTRACTORS

- A. After the bid opening, the apparent low bidder, and if deemed advisable, the apparent second or third low bidders shall submit the schedule of values and the entire list of subcontractors, used in formulating their respective bids, to the County Project Manager within 72 hours.
1. If a bidder has any doubt regarding the correctness or acceptability of any subcontract proposal, the bidder may submit the names and amount of other competing subcontractors, making sure that the bidder clearly states which one was used in formulating his proposal.
- B. Schedule of Values must be agreed to by all parties prior to first pay application. No changes to the approved Schedule of Values will be allowed except by change order.
- C. Changes to the original List of Subcontractors involving major subcontractors will not be allowed except with the approval of the County.

#### 1.12 CONTRACTOR SUPERVISION

- A. The contractor shall designate and keep continuously on the project, during its progress and until the project is finally accepted, an experienced and competent superintendent and any necessary assistants, all satisfactory to the County's project representative. The superintendent shall not be changed except with the consent of the County's project representative unless the superintendent proves to be unsatisfactory to the contractor and ceases to be in his employ.
- B. The superintendent shall represent the contractor in his absence and all notices, requests and instructions given to the superintendent shall be considered as having been given to the contractor.
- C. The contractor shall give efficient supervision to the work, using his best skill and attention. The contractor shall carefully study and compare all drawings, specifications and other instructions giving prompt notice to the Architect of any errors, inconsistency, or omission which have been discovered, but shall not be held responsible for their existence or discovery.



1.13 CONTRACTOR DAILY RECORD

- A. The contractor, at each scheduled progress meeting, shall provide the county project manager with a copy of their daily work log. This refers to the daily report that documents the number of staff on site, materials delivered, sub-contractor activity, etc. This report will provide information to be compared against the approved work schedule.

1.14 LIQUIDATED DAMAGES

- A. It is recognized and agreed by the contractor and County that it is of importance to the County to have this project completed within the time schedule contained in the contract documents. Should the contractor fail to complete the work within the time stated in the Agreement or within such additional time as may have been allowed by change order extension, there shall be deducted from any moneys due, or that may become due the contractor, the sum per day (as defined in each contract), for each and every calendar day beyond the agreed or extended completion day, that the work remains uncompleted. Such sum is fixed and agreed upon by the County and the contractor as liquidated damages due the County by reason of the inconvenience and added costs of administration, loss of use and/or revenue and supervision resulting from the contractor's default, and not as penalty.
1. Permitting the contractor to continue and finish the work or any part of it after the time fixed for its completion, or after the date to which the time for completion, or after the date to which the time for completion may have been extended, shall in no way operate as a waiver on the part of the County or any of their rights under the contract.
  2. Said liquidated damage provision shall remain in effect and continue until substantial completion and acceptance of the project by the County. The contractor hereby authorizes the County to retain sufficient amounts of money due it and remaining in the hands of the county to pay the damages caused by any such default or defaults.

PART 2 - PRODUCTS (Not Used)

PART 3 - EXECUTION (Not Used)

**END OF SECTION 01 1000**

## SECTION 01 23 00 - ALTERNATES

### PART 1 - GENERAL

#### 1.1 SUMMARY

- A. Section includes administrative and procedural requirements for alternates.

#### 1.2 DEFINITIONS

- A. Alternate: An amount proposed by bidders and stated on the Bid Form for certain work defined in the bidding requirements that may be added to or deducted from the base bid amount if the Owner decides to accept a corresponding change either in the amount of construction to be completed or in the products, materials, equipment, systems, or installation methods described in the Contract Documents.
  - 1. Alternates described in this Section are part of the Work only if enumerated in the Agreement.
  - 2. The cost or credit for each alternate is the net addition to or deduction from the Contract Sum to incorporate alternates into the Work. No other adjustments are made to the Contract Sum.

#### 1.3 PROCEDURES

- A. Coordination: Revise or adjust affected adjacent work as necessary to completely integrate work of the alternate into Project.
  - 1. Include as part of each alternate, miscellaneous devices, accessory objects, and similar items incidental to or required for a complete installation whether or not indicated as part of alternate.
  - 2. Include as part of each alternate any construction schedule impacts associated with the scope of the alternate.
- B. Execute accepted alternates under the same conditions as other work of the Contract.
- C. Schedule: A schedule of alternates is included at the end of this Section. Specification Sections referenced in schedule contain requirements for materials necessary to achieve the work described under each alternate.

### PART 2 - PRODUCTS (Not Used)

### PART 3 - EXECUTION

#### 3.1 SCHEDULE OF ALTERNATES

##### A. **Alternate #1: REPLACE EXISTING WINDOWS**

- 1. **Base Bid:** No work associated with existing exterior windows.
- 2. **Additive Alternate:** Remove existing punched windows, typical of 5 locations, and replace with new insulated low-E reflective glazing in fixed aluminum window frames to match storefront system. Work includes removing adjacent exterior wood trim, installing flashing and re-installing wood trim as necessary for watertight installation. Water test (hose stream) to be performed on all windows.

**B. Alternate #2: RE-USE EXISTING PEX PLUMBING PIPING**

1. **Base Bid:** Remove previously-installed PEX plumbing piping where exposed Replace with new copper piping. All underground PEX to remain. Connect new copper piping to existing underground PEX per code and standard of industry.
2. **Deductive Alternate:** Test existing PEX plumbing piping to confirm functionality. If found to have no leaks and to be in 'like new' condition, leave in place/continue use of PEX system for new plumbing fixtures. Contractor to fully warranty system as if new."

**C. Alternate #3: LOADING DOCK ENCLOSURE**

1. **Base Bid:** Enclose covered loading dock with storefront system, infill/build out 2 offices and associated mechanical/electrical systems. Build out new vestibule and exit door.
2. **Deductive Alternate:** Leave loading dock, do not enclose/build out new offices. Remove double door and install new storefront in opening. Install new hardware in hollow metal exterior door. County will provide and install new fall protection guardrail across width of dock edge.

**D. Alternate #4: UNISEX STAFF RESTROOM**

1. **Base Bid:** Build out room 116 as unisex toilet room, including toilet, sink, and related plumbing and toilet room accessories.
2. **Deductive Alternate:** Eliminate toilet, sink, associated plumbing and accessories. Finish out room to match Room 124, including revision of door hardware.

**END OF SECTION 01 23 00**

## SECTION 01 25 00 - SUBSTITUTION PROCEDURES

### PART 1 - GENERAL

#### 1.1 SUMMARY

- A. Section includes administrative and procedural requirements for substitutions.

#### 1.2 DEFINITIONS

- A. Substitutions: Changes in products, materials, equipment, and methods of construction from those required by the Contract Documents and proposed by Contractor.
1. Substitutions for Cause: Changes proposed by Contractor that are required due to changed Project conditions, such as unavailability of product, regulatory changes, or unavailability of required warranty terms.
  2. Substitutions for Convenience: Changes proposed by Contractor or Owner that are not required in order to meet other Project requirements but may offer advantage to Contractor or Owner.

#### 1.3 SUBSTITUTION REQUEST DATA

- A. Substitution Requests: Submit substitution requests within two business days from of bid opening as noted in Division 00 'Instructions to Bidders'. Submit three copies of each request for consideration. Include supporting documentation as noted below. Identify product or fabrication or installation method to be replaced. Include Specification Section number and title and Drawing numbers and titles.
1. Documentation: Show compliance with requirements for substitutions and the following, as applicable:
    - a. Statement indicating why specified product or fabrication or installation method cannot be provided, if applicable.
    - b. Coordination of information, including a list of changes or revisions needed to other parts of the Work and to construction performed by Owner and separate contractors that will be necessary to accommodate proposed substitution.
    - c. Detailed comparison of significant qualities of proposed substitutions with those of the Work specified. Include annotated copy of applicable Specification Section. Significant qualities may include attributes, such as **performance, weight, size, durability, visual effect, sustainable design characteristics, warranties, and specific features and requirements indicated**. Indicate deviations, if any, from the Work specified.
    - d. Product Data, including drawings and descriptions of products and fabrication and installation procedures.
    - e. Samples, where applicable or requested.
    - f. Certificates and qualification data, where applicable or requested.
    - g. Material test reports from a qualified testing agency, indicating and interpreting test results for compliance with requirements indicated.
    - h. Research reports evidencing compliance with building code in effect for Project, from CBC..
    - i. Cost information, including a proposal of change, if any, in the Contract Sum.
    - j. Contractor's certification that proposed substitution complies with requirements in the Contract Documents, except as indicated in substitution request, is compatible with related materials and is appropriate for applications indicated.

- k. Contractor's waiver of rights to additional payment or time that may subsequently become necessary because of failure of proposed substitution to produce indicated results.
    - 2. Architect's Action: If necessary, Architect will request additional information or documentation for evaluation within seven days of receipt of a request for substitution. Architect will notify Contractor of acceptance or rejection of proposed substitution within seven days of receipt of request, or seven days of receipt of additional information or documentation, whichever is later.
      - a. Forms of Acceptance: Change Order, Construction Change Directive, or Architect's Supplemental Instructions for minor changes in the Work.
      - b. Use product specified if Architect does not issue a decision on use of a proposed substitution within time allocated.
- 1.4 QUALITY ASSURANCE
- A. Compatibility of Substitutions: Investigate and document compatibility of proposed substitution with related products and materials. Engage a qualified testing agency to perform compatibility tests recommended by manufacturers.
- 1.5 PROCEDURES
- A. Coordination: Revise or adjust affected work as necessary to integrate work of the approved substitutions.
- 1.6 SUBSTITUTIONS
- A. Substitutions for Cause: Submit requests for substitution immediately on discovery of need for change, but not later than 15 days prior to time required for preparation and review of related submittals.
    - 1. Conditions: Architect will consider Contractor's request for substitution when the following conditions are satisfied. If the following conditions are not satisfied, Architect will return requests without action, except to record noncompliance with these requirements:
      - a. Requested substitution is consistent with the Contract Documents and will produce indicated results.
      - b. Substitution request is fully documented and properly submitted.
      - c. Requested substitution will not adversely affect Contractor's construction schedule.
      - d. Requested substitution has received necessary approvals of authorities having jurisdiction.
      - e. Requested substitution is compatible with other portions of the Work.
      - f. Requested substitution has been coordinated with other portions of the Work.
      - g. Requested substitution provides specified warranty.
      - h. If requested substitution involves more than one contractor, requested substitution has been coordinated with other portions of the Work, is uniform and consistent, is compatible with other products, and is acceptable to all contractors involved.
  - B. Substitutions for Convenience: Not allowed if not submitted within two days of bid opening per Division 00 'Instructions to Bidders'.

PART 2 - PRODUCTS (Not Used)

PART 3 - EXECUTION (Not Used)

**END OF SECTION 01 25 00**

## SECTION 01 33 00 - SUBMITTAL PROCEDURES

### PART 1 - GENERAL

#### 1.1 SUMMARY

- A. Section Includes:
  - 1. Submittal schedule requirements.
  - 2. Administrative and procedural requirements for submittals.

#### 1.2 DEFINITIONS

- A. Action Submittals: Written and graphic information and physical samples that require Architect's responsive action. Action submittals are those submittals indicated in individual Specification Sections as "action submittals."
- B. Informational Submittals: Written and graphic information and physical samples that do not require Architect's responsive action. Submittals may be rejected for not complying with requirements. Informational submittals are those submittals indicated in individual Specification Sections as "informational submittals."

#### 1.3 SUBMITTAL SCHEDULE

- A. Submittal Schedule: Submit within 5 working days after notice to proceed, as an action submittal, a list of submittals, arranged in chronological order by dates required by construction schedule. Include time required for review, ordering, manufacturing, fabrication, and delivery when establishing dates. Include additional time required for making corrections or revisions to submittals noted by Architect and additional time for handling and reviewing submittals required by those corrections.

#### 1.4 SUBMITTAL FORMATS

- A. Submittal Information: Include the following information in each submittal:
  - 1. Project name.
  - 2. Date.
  - 3. Name of Contractor.
  - 4. Contractor's stamp, with date and signature indicated the submittal has been reviewed and is conformance with contract requirements.
  - 5. Name of firm or entity that prepared submittal.
  - 6. Names of subcontractor, manufacturer, and supplier.
  - 7. Unique submittal number, including revision identifier. Include Specification Section number with sequential alphanumeric identifier; and alphanumeric suffix for resubmittals.
  - 8. Category and type of submittal.
  - 9. Submittal purpose and description.
  - 10. Drawing number and detail references, as appropriate.
  - 11. Location(s) where product is to be installed, as appropriate.
  - 12. Other necessary identification.
  - 13. Remarks.
  - 14. Signature of transmitter.
- B. Options: Identify options requiring selection by Architect.

- C. Deviations and Additional Information: On each submittal, clearly indicate deviations from requirements in the Contract Documents, including minor variations and limitations; include relevant additional information and revisions, other than those requested by Architect on previous submittals. Indicate by highlighting on each submittal or noting on attached separate sheet.
- D. PDF Submittals: Prepare submittals as PDF package, incorporating complete information into each PDF file. Name PDF file with submittal number, which should either have a sequential number or be the specification section. The submittal should reference the specification section.
- E. Submittals for Web-Based Project Software: Prepare submittals as PDF files, or other format indicated by Project software website.

#### 1.5 SUBMITTAL PROCEDURES

- A. Prepare and submit submittals required by individual Specification Sections. Types of submittals are indicated in individual Specification Sections.
  - 1. Email: Prepare submittals as PDF package, and transmit to Architect by sending via email. Include PDF transmittal form. Include information in email subject line as requested by Architect.
  - 2. Web-Based Project Software: Prepare submittals in PDF form, and upload to web-based Project software website. Enter required data in web-based software site to fully identify submittal.
- B. Coordination: Coordinate preparation and processing of submittals with performance of construction activities.
  - 1. Coordinate each submittal with fabrication, purchasing, testing, delivery, other submittals, and related activities that require sequential activity.
  - 2. Submittals related to interior finishes should be held and submitted all together, at the same time, such that they can be reviewed together.
  - 3. Submit all submittal items required for each Specification Section concurrently unless partial submittals for portions of the Work are indicated on approved submittal schedule.
  - 4. Submit action submittals and informational submittals required by the same Specification Section as separate packages under separate transmittals.
- C. Processing Time: Allow time for submittal review, including time for resubmittals, as follows. Time for review shall commence on Architect's receipt of submittal. No extension of the Contract Time will be authorized because of failure to transmit submittals enough in advance of the Work to permit processing, including resubmittals.
  - 1. Initial Review: Allow 10 working days for initial review of each submittal. Allow additional time if coordination with subsequent submittals is required. Architect will advise Contractor when a submittal being processed must be delayed for coordination.
  - 2. Resubmittal Review: Allow 10 working days for review of each resubmittal.
  - 3. Any submittal received after 3:00 pm will be considered as having been received in the next working day.
  - 4. No extension of Contract Time will be authorized because of a failure to transmit submittals to the Architect in sufficient time before the work is to be performed.
- D. Resubmittals: Make resubmittals in same form and number of copies as initial submittal.



- E. Distribution: Furnish copies of final submittals to manufacturers, subcontractors, suppliers, fabricators, installers, authorities having jurisdiction, and others as necessary for performance of construction activities. Show distribution on transmittal forms.
- F. Use for Construction: Retain complete copies of submittals on Project site. Use only final action submittals that are marked with approval notation from Architect's action stamp.

#### 1.6 SUBMITTAL REQUIREMENTS

- A. Product Data: Collect information into a single submittal for each element of construction and type of product or equipment.
  - 1. If information must be specially prepared for submittal because standard published data are unsuitable for use, submit as Shop Drawings, not as Product Data.
  - 2. Mark each copy of each submittal to show which products and options are applicable.
  - 3. Include the following information, as applicable:
    - a. Manufacturer's catalog cuts.
    - b. Manufacturer's product specifications.
    - c. Standard color charts.
    - d. Statement of compliance with specified referenced standards.
    - e. Testing by recognized testing agency.
    - f. Application of testing agency labels and seals.
    - g. Notation of coordination requirements.
    - h. Availability and delivery time information.
  - 4. For equipment, include the following in addition to the above, as applicable:
    - a. Wiring diagrams that show factory-installed wiring.
    - b. Printed performance curves.
    - c. Operational range diagrams.
    - d. Clearances required to other construction, if not indicated on accompanying Shop Drawings.
  - 5. Submit Product Data before Shop Drawings, and before or concurrent with Samples.
- B. Shop Drawings: Prepare Project-specific information, drawn accurately to scale. Do not base Shop Drawings on reproductions of the Contract Documents or standard printed data unless submittal based on Architect's digital data drawing files is otherwise permitted.
  - 1. Preparation: Fully illustrate requirements in the Contract Documents. Include the following information, as applicable:
    - a. Identification of products.
    - b. Schedules.
    - c. Compliance with specified standards.
    - d. Notation of coordination requirements.
    - e. Notation of dimensions established by field measurement.
    - f. Relationship and attachment to adjoining construction clearly indicated.
    - g. Seal and signature of professional engineer if specified.
- C. Samples: Submit Samples for review of kind, color, pattern, and texture for a check of these characteristics with other materials.

1. Transmit Samples that contain multiple, related components such as accessories together in one submittal package.
2. Physical samples of each finish/color provided must be on the actual material being used for the product. Digital color selections or brochures with printed color samples will not be reviewed for selection or approval processes.
3. Identification: Permanently attach label on unexposed side of Samples that includes the following:
  - a. Project name and submittal number.
  - b. Generic description of Sample.
  - c. Product name and name of manufacturer.
  - d. Sample source.
  - e. Number and title of applicable Specification Section.
  - f. Specification paragraph number and generic name of each item.
4. Email Transmittal: Provide PDF transmittal. Include digital image file illustrating Sample characteristics, and identification information for record.
5. Disposition: Maintain sets of approved Samples at Project site, available for quality-control comparisons throughout the course of construction activity. Sample sets may be used to determine final acceptance of construction associated with each set.
  - a. Samples that may be incorporated into the Work are indicated in individual Specification Sections. Such Samples must be in an undamaged condition at time of use.
  - b. Samples not incorporated into the Work, or otherwise designated as Owner's property, are the property of Contractor.
6. Samples for Initial Selection: Submit manufacturer's color charts consisting of units or sections of units showing the full range of colors, textures, and patterns available.
  - a. Number of Samples: Submit a minimum of two full set(s) of available choices where color, pattern, texture, or similar characteristics are required to be selected from manufacturer's product line. Architect will return one sample with options selected.
7. Samples for Verification: Submit full-size units or Samples of size indicated, prepared from same material to be used for the Work, cured and finished in manner specified, and physically identical with material or product proposed for use, and that show full range of color and texture variations expected. Samples include, but are not limited to, the following: partial sections of manufactured or fabricated components; small cuts or containers of materials; complete units of repetitively used materials; swatches showing color, texture, and pattern; color range sets; and components used for independent testing and inspection.
  - a. Number of Samples: Submit three sets of Samples. Architect will retain two Sample sets; remainder will be returned. Mark up and retain one returned Sample set as a project record Sample.
    - 1) Submit a single Sample where assembly details, workmanship, fabrication techniques, connections, operation, and other similar characteristics are to be demonstrated.
    - 2) If variation in color, pattern, texture, or other characteristic is inherent in material or product represented by a Sample, submit at least three sets of paired units that show approximate limits of variations.

- D. Product Schedule: As required in individual Specification Sections, prepare a written summary indicating types of products required for the Work and their intended location. Include the following information in tabular form:
- E. Qualification Data: Prepare written information that demonstrates capabilities and experience of firm or person. Include lists of completed projects with project names and addresses, contact information of architects and owners, and other information specified.
- F. Design Data: Prepare and submit written and graphic information indicating compliance with indicated performance and design criteria in individual Specification Sections. Include list of assumptions and summary of loads. Include load diagrams if applicable. Provide name and version of software, if any, used for calculations. Number each page of submittal.
- G. Certificates:
1. Certificates and Certifications Submittals: Submit a statement that includes signature of entity responsible for preparing certification. Certificates and certifications shall be signed by an officer or other individual authorized to sign documents on behalf of that entity. Provide a notarized signature where indicated.
  2. Installer Certificates: Submit written statements on manufacturer's letterhead certifying that Installer complies with requirements in the Contract Documents and, where required, is authorized by manufacturer for this specific Project.
  3. Manufacturer Certificates: Submit written statements on manufacturer's letterhead certifying that manufacturer complies with requirements in the Contract Documents. Include evidence of manufacturing experience where required.
  4. Material Certificates: Submit written statements on manufacturer's letterhead certifying that material complies with requirements in the Contract Documents.
  5. Product Certificates: Submit written statements on manufacturer's letterhead certifying that product complies with requirements in the Contract Documents.
  6. Welding Certificates: Prepare written certification that welding procedures and personnel comply with requirements in the Contract Documents. Submit record of Welding Procedure Specification and Procedure Qualification Record on AWS forms. Include names of firms and personnel certified.
- H. Test and Research Reports:
1. Compatibility Test Reports: Submit reports written by a qualified testing agency, on testing agency's standard form, indicating and interpreting results of compatibility tests performed before installation of product. Include written recommendations for primers and substrate preparation needed for adhesion.
  2. Field Test Reports: Submit written reports indicating and interpreting results of field tests performed either during installation of product or after product is installed in its final location, for compliance with requirements in the Contract Documents.
  3. Material Test Reports: Submit reports written by a qualified testing agency, on testing agency's standard form, indicating and interpreting test results of material for compliance with requirements in the Contract Documents.
  4. Preconstruction Test Reports: Submit reports written by a qualified testing agency, on testing agency's standard form, indicating and interpreting results of tests performed before installation of product, for compliance with performance requirements in the Contract Documents.
  5. Product Test Reports: Submit written reports indicating that current product produced by manufacturer complies with requirements in the Contract Documents. Base reports on evaluation of tests performed by manufacturer and witnessed by a qualified testing agency, or on comprehensive tests performed by a qualified testing agency.

6. Research Reports: Submit written evidence, from a model code organization acceptable to authorities having jurisdiction, that product complies with building code in effect for Project. Include the following information:
  - a. Name of evaluation organization.
  - b. Date of evaluation.
  - c. Time period when report is in effect.
  - d. Product and manufacturers' names.
  - e. Description of product.
  - f. Test procedures and results.
  - g. Limitations of use.

#### 1.7 CONTRACTOR'S REVIEW

- A. Action Submittals and Informational Submittals: Review each submittal and check for coordination with other Work of the Contract and for compliance with the Contract Documents. Note corrections and field dimensions. Mark with approval stamp before submitting to Architect.
- B. Contractor's Approval: Indicate Contractor's approval for each submittal with a uniform approval stamp. Include name of reviewer, date of Contractor's approval, and statement certifying that submittal has been reviewed, checked, and approved for compliance with the Contract Documents.
  1. Architect will not review submittals received from Contractor that do not have Contractor's review and approval.

#### 1.8 ARCHITECT'S REVIEW

- A. Action Submittals: Architect will review each submittal, indicate corrections or revisions required.
  1. PDF Submittals: Architect will indicate, via markup on each submittal, the appropriate action.
- B. Informational Submittals: Architect will review each submittal and will not return it, or will return it if it does not comply with requirements. Architect will forward each submittal to appropriate party.
- C. Partial submittals prepared for a portion of the Work will be reviewed when use of partial submittals has received prior approval from Architect.
- D. Incomplete submittals are unacceptable, will be considered nonresponsive, and will be returned for resubmittal without review.
- E. Architect will return without review submittals received from sources other than Contractor.
- F. Submittals not required by the Contract Documents will be returned by Architect without action.

PART 2 - PRODUCTS (Not Used)

PART 3 - EXECUTION (Not Used)

**END OF SECTION 01 33 00**

## **SECTION 01 50 00 - TEMPORARY FACILITIES AND CONTROLS**

### **PART 1 - GENERAL**

#### **1.1 SUMMARY**

- A. Section includes requirements for temporary utilities, support facilities, and security and protection facilities.

#### **1.2 USE CHARGES**

- A. General: Installation and removal of and use charges for temporary facilities shall be included in the Contract Sum unless otherwise indicated. Allow other entities engaged in the Project to use temporary services and facilities without cost, including, but not limited to, Owner's construction forces, Architect testing agencies, and authorities having jurisdiction.
- B. Water and Sewer Service from Existing System: Water from Owner's existing water system is available for use without metering and without payment of use charges. Provide connections and extensions of services as required for construction operations.
- C. Electric Power Service from Existing System: Electric power from Owner's existing system is available for use without metering and without payment of use charges. Provide connections and extensions of services as required for construction operations.
  - 1. If power is required to be shut off for Contractor to perform work on that system, then the Contractor must make provisions for temporary generator to provide appropriate power for jobsite safety and work operations.

#### **1.3 INFORMATIONAL SUBMITTALS**

- A. Fire-Safety Program: Show compliance with requirements of NFPA 241 and authorities having jurisdiction. Indicate Contractor personnel responsible for management of fire-prevention program.
- B. Moisture-and Mold-Protection Plan: Describe procedures and controls for protecting materials and construction from water absorption and damage and mold.
- C. Dust- and HVAC-Control Plan: Submit coordination drawing and narrative that indicates the dust- and HVAC-control measures proposed for use, proposed locations, and proposed time frame for their operation. Include the following:
  - 1. Locations of dust-control partitions at each phase of work.
  - 2. HVAC system isolation schematic drawing.
  - 3. Location of proposed air-filtration system discharge.
  - 4. Waste-handling procedures.
  - 5. Other dust-control measures.

#### **1.4 QUALITY ASSURANCE**

- A. Electric Service: Comply with NECA, NEMA, and UL standards and regulations for temporary electric service. Install service to comply with NFPA 70.
- B. Tests and Inspections: Arrange for authorities having jurisdiction to test and inspect each temporary utility before use. Obtain required certifications and permits.

## 1.5 PROJECT CONDITIONS

- A. Temporary Use of Permanent Facilities: Engage Installer of each permanent service to assume responsibility for operation, maintenance, and protection of each permanent service during its use as a construction facility before Owner's acceptance, regardless of previously assigned responsibilities.

## PART 2 - PRODUCTS

### 2.1 TEMPORARY FACILITIES

- A. Field Offices, General: Not required.

### 2.2 EQUIPMENT

- A. Fire Extinguishers: Portable, UL rated; with class and extinguishing agent as required by locations and classes of fire exposures.
- B. HVAC Equipment: Provide vented, self-contained, liquid-propane-gas or fuel-oil heaters with individual space thermostatic control.
  - 1. Use of gasoline-burning space heaters, open-flame heaters, or salamander-type heating units is prohibited.
  - 2. Heating Units: Listed and labeled for type of fuel being consumed, by a qualified testing agency acceptable to authorities having jurisdiction, and marked for intended location and application.
  - 3. Building HVAC System: Building HVAC system shall NOT be used during construction.

## PART 3 - EXECUTION

### 3.1 TEMPORARY UTILITY INSTALLATION

- A. General: Install temporary service or connect to existing service.
  - 1. Arrange with utility company, Owner, and existing users for time when service can be interrupted, if necessary, to make connections for temporary services.
- B. Sanitary Facilities: Provide temporary toilets, wash facilities, and drinking water for use of construction personnel. Comply with requirements of authorities having jurisdiction for type, number, location, operation, and maintenance of fixtures and facilities. Building toilet rooms shall not be used.
- C. Temporary Heating and Cooling: Provide temporary heating and cooling required by construction activities for curing or drying of completed installations or for protecting installed construction from adverse effects of low temperatures or high humidity. Select equipment that will not have a harmful effect on completed installations or elements being installed.
  - 1. Provide temporary dehumidification systems when required to reduce ambient and substrate moisture levels to level required to allow installation or application of finishes and their proper curing or drying.
- D. Lighting: Provide temporary lighting with local switching that provides adequate illumination for construction operations, observations, inspections, and traffic conditions.

1. Install and operate temporary lighting that fulfills security and protection requirements without operating entire system.

### 3.2 SUPPORT FACILITIES INSTALLATION

- A. Waste Disposal Facilities: Comply with requirements specified in Section 01 74 19 "Construction Waste Management and Disposal."
- B. Waste Disposal Facilities: Provide waste-collection containers in sizes adequate to handle waste from construction operations. Comply with requirements of authorities having jurisdiction. Comply with progress cleaning requirements in Section 01 73 00 "Execution."

### 3.3 SECURITY AND PROTECTION FACILITIES INSTALLATION

- A. Protection of Existing Facilities: Protect existing vegetation, equipment, structures, utilities, and other improvements at Project site and on adjacent properties, except those indicated to be removed or altered. Repair damage to existing facilities.
  1. Where access to adjacent properties is required in order to affect protection of existing facilities, obtain written permission from adjacent property owner to access property for that purpose.
- B. Environmental Protection: Provide protection, operate temporary facilities, and conduct construction as required to comply with environmental regulations and that minimize possible air, waterway, and subsoil contamination or pollution or other undesirable effects.
- C. Temporary Fire Protection: Install and maintain temporary fire-protection facilities of types needed to protect against reasonably predictable and controllable fire losses. Comply with NFPA 241; manage fire-prevention program.
  1. Prohibit smoking in construction areas. Comply with additional limits on smoking specified in other Sections.
  2. Supervise welding operations, combustion-type temporary heating units, and similar sources of fire ignition according to requirements of authorities having jurisdiction.
  3. Develop and supervise an overall fire-prevention and -protection program for personnel at Project site. Instruct personnel in methods and procedures. Post warnings and information.

### 3.4 MOISTURE AND MOLD CONTROL

- A. Contractor's Moisture-Protection Plan: Describe delivery, handling, storage, installation, and protection provisions for materials subject to water absorption or water damage.
  1. Indicate procedures for discarding water-damaged materials, protocols for mitigating water intrusion into completed Work, and replacing water-damaged Work.
  2. Indicate sequencing of work that requires water, such as sprayed fire-resistive materials, plastering, and terrazzo grinding, and describe plans for dealing with water from these operations. Show procedures for verifying that wet construction has dried sufficiently to permit installation of finish materials.
  3. Indicate methods to be used to avoid trapping water in finished work.
- B. Exposed Construction Period: Before installation of weather barriers, when materials are subject to wetting and exposure and to airborne mold spores, protect as follows:
  1. Protect porous materials from water damage.



2. Protect stored and installed material from flowing or standing water.
  3. Keep porous and organic materials from coming into prolonged contact with concrete.
  4. Remove standing water from decks.
  5. Keep deck openings covered or dammed.
- C. Partially Enclosed Construction Period: After installation of weather barriers but before full enclosure and conditioning of building, when installed materials are still subject to infiltration of moisture and ambient mold spores, protect as follows:
1. Do not load or install drywall or other porous materials or components, or items with high organic content, into partially enclosed building.
  2. Keep interior spaces reasonably clean and protected from water damage.
  3. Periodically collect and remove waste containing cellulose or other organic matter.
  4. Discard or replace water-damaged material.
  5. Do not install material that is wet.
  6. Discard and replace stored or installed material that begins to grow mold.
  7. Perform work in a sequence that allows wet materials adequate time to dry before enclosing the material in gypsum board or other interior finishes.
- D. Controlled Construction Period: After completing and sealing of the building enclosure but prior to the full operation of permanent HVAC systems, maintain as follows:
1. Control moisture and humidity inside building by maintaining effective dry-in conditions.
  2. Use temporary or permanent HVAC system to control humidity within ranges specified for installed and stored materials.
  3. Comply with manufacturer's written instructions for temperature, relative humidity, and exposure to water limits.

**END OF SECTION**

## **SECTION 01 73 00 - EXECUTION**

### **PART 1 - GENERAL**

#### **1.1 SUMMARY**

- A. Section includes general administrative and procedural requirements governing execution of the Work including, but not limited to, the following:
  - 1. Construction layout.
  - 2. Field engineering and surveying.
  - 3. Installation of the Work.
  - 4. Cutting and patching.
  - 5. Progress cleaning.
  - 6. Starting and adjusting.
  - 7. Protection of installed construction.

#### **1.2 INFORMATIONAL SUBMITTALS**

- A. Landfill Receipts: Submit copy of receipts issued by a landfill facility, licensed to accept hazardous materials, for hazardous waste disposal.

#### **1.3 QUALITY ASSURANCE**

- A. Cutting and Patching: Comply with requirements for and limitations on cutting and patching of construction elements.
  - 1. Structural Elements: When cutting and patching structural elements, notify Architect of locations and details of cutting and await directions from Architect before proceeding. Shore, brace, and support structural elements during cutting and patching. Do not cut and patch structural elements in a manner that could change their load-carrying capacity or increase deflection.
  - 2. Operational Elements: Do not cut and patch operating elements and related components in a manner that results in reducing their capacity to perform as intended or that results in increased maintenance or decreased operational life or safety.
  - 3. Other Construction Elements: Do not cut and patch other construction elements or components in a manner that could change their load-carrying capacity, that results in reducing their capacity to perform as intended, or that results in increased maintenance or decreased operational life or safety.
  - 4. Visual Elements: Do not cut and patch construction in a manner that results in visual evidence of cutting and patching. Do not cut and patch exposed construction in a manner that would, in Architect's opinion, reduce the building's aesthetic qualities. Remove and replace construction that has been cut and patched in a visually unsatisfactory manner.
- B. Manufacturer's Installation Instructions: Obtain and maintain on-site manufacturer's written recommendations and instructions for installation of products and equipment.

### **PART 2 - PRODUCTS**

#### **2.1 MATERIALS**

- A. General: Comply with requirements specified in other Sections.

1. For projects requiring compliance with sustainable design and construction practices and procedures, use products for patching that comply with sustainable design requirements.
- B. In-Place Materials: Use materials for patching identical to in-place materials. For exposed surfaces, use materials that visually match in-place adjacent surfaces to the fullest extent possible.
  1. If identical materials are unavailable or cannot be used, use materials that, when installed, will provide a match acceptable to Architect for the visual and functional performance of in-place materials.

## PART 3 - EXECUTION

### 3.1 EXAMINATION

- A. Examination and Acceptance of Conditions: Before proceeding with each component of the Work, examine substrates, areas, and conditions, with Installer or Applicator present where indicated, for compliance with requirements for installation tolerances and other conditions affecting performance. Record observations.
  1. Examine roughing-in for mechanical and electrical systems to verify actual locations of connections before equipment and fixture installation.
  2. Examine walls, floors, and roofs for suitable conditions where products and systems are to be installed.
  3. Verify compatibility with and suitability of substrates, including compatibility with existing finishes or primers.
- B. Proceed with installation only after unsatisfactory conditions have been corrected. Proceeding with the Work indicates acceptance of surfaces and conditions.

### 3.2 PREPARATION

- A. Existing Utility Information: Furnish information to local utility and [Owner] that is necessary to adjust, move, or relocate existing utility structures, utility poles, lines, services, or other utility appurtenances located in or affected by construction. Coordinate with authorities having jurisdiction.
- B. Field Measurements: Take field measurements as required to fit the Work properly. Recheck measurements before installing each product. Where portions of the Work are indicated to fit to other construction, verify dimensions of other construction by field measurements before fabrication. Coordinate fabrication schedule with construction progress to avoid delaying the Work.
- C. Space Requirements: Verify space requirements and dimensions of items shown diagrammatically on Drawings.
- D. Review of Contract Documents and Field Conditions: Immediately on discovery of the need for clarification of the Contract Documents caused by differing field conditions outside the control of Contractor, submit a request for information to Architect according to requirements in Section 01 31 00 "Project Management and Coordination."

### 3.3 CONSTRUCTION LAYOUT

- A. Verification: Before proceeding to lay out the Work, verify layout information shown on Drawings. If discrepancies are discovered, notify Architect promptly.

- B. General: Contractor to lay out the Work using accepted practices.
  - 1. Establish dimensions within tolerances indicated. Do not scale Drawings to obtain required dimensions.
  - 2. Inform installers of lines and levels to which they must comply.
  - 3. Check the location, level and plumb, of every major element as the Work progresses.
  - 4. Notify Architect when deviations from required lines and levels exceed allowable tolerances.
- C. Building Lines and Levels: Locate and lay out control lines for structures, and grids, including those required for mechanical and electrical work.

### 3.4 INSTALLATION

- A. General: Locate the Work and components of the Work accurately, in correct alignment and elevation, as indicated.
  - 1. Make vertical work plumb and make horizontal work level.
  - 2. Where space is limited, install components to maximize space available for maintenance and ease of removal for replacement.
  - 3. Conceal pipes, ducts, and wiring in finished areas unless otherwise indicated.
- B. Comply with manufacturer's written instructions and recommendations for installing products in applications indicated.
- C. Install products at the time and under conditions that will ensure the best possible results. Maintain conditions required for product performance until Substantial Completion.
- D. Conduct construction operations so no part of the Work is subjected to damaging operations or loading in excess of that expected during normal conditions of occupancy.
- E. Sequence the Work and allow adequate clearances to accommodate movement of construction items on site and placement in permanent locations.
- F. Tools and Equipment: Where possible, select tools or equipment that minimize production of excessive noise levels.
- G. Templates: Obtain and distribute to the parties involved templates for work specified to be factory prepared and field installed. Check Shop Drawings of other portions of the Work to confirm that adequate provisions are made for locating and installing products to comply with indicated requirements.
- H. Attachment: Provide blocking and attachment plates and anchors and fasteners of adequate size and number to securely anchor each component in place, accurately located and aligned with other portions of the Work. Where size and type of attachments are not indicated, verify size and type required for load conditions.
  - 1. Mounting Heights: Where mounting heights are not indicated, mount components at heights directed by Architect.
  - 2. Allow for building movement, including thermal expansion and contraction.
  - 3. Coordinate installation of anchorages. Furnish setting drawings, templates, and directions for installing anchorages, including sleeves, concrete inserts, anchor bolts, and items with integral anchors, that are to be embedded in concrete or masonry. Deliver such items to Project site in time for installation.

- I. Joints: Make joints of uniform width. Where joint locations in exposed work are not indicated, arrange joints for the best visual effect. Fit exposed connections together to form hairline joints.
- J. Remove and replace damaged, defective, or non-conforming Work.

### 3.5 CUTTING AND PATCHING

- A. Cutting and Patching, General: Employ skilled workers to perform cutting and patching. Proceed with cutting and patching at the earliest feasible time, and complete without delay.
  - 1. Cut in-place construction to provide for installation of other components or performance of other construction, and subsequently patch as required to restore surfaces to their original condition.
- B. Existing Warranties: Remove, replace, patch, and repair materials and surfaces cut or damaged during installation or cutting and patching operations, by methods and with materials so as not to void existing warranties.
- C. Temporary Support: Provide temporary support of work to be cut.
- D. Protection: Protect in-place construction during cutting and patching to prevent damage. Provide protection from adverse weather conditions for portions of Project that might be exposed during cutting and patching operations.
- E. Cutting: Cut in-place construction by sawing, drilling, breaking, chipping, grinding, and similar operations, including excavation, using methods least likely to damage elements retained or adjoining construction. If possible, review proposed procedures with original Installer; comply with original Installer's written recommendations.
  - 1. In general, use hand or small power tools designed for sawing and grinding, not hammering and chopping. Cut holes and slots neatly to minimum size required, and with minimum disturbance of adjacent surfaces. Temporarily cover openings when not in use.
  - 2. Finished Surfaces: Cut or drill from the exposed or finished side into concealed surfaces.
  - 3. Masonry: Cut using a cutting machine, such as an abrasive saw or a diamond-core drill.
  - 4. Excavating and Backfilling: Comply with requirements in applicable Sections where required by cutting and patching operations.
  - 5. Mechanical and Electrical Services: Cut off pipe or conduit in walls or partitions to be removed. Cap, valve, or plug and seal remaining portion of pipe or conduit to prevent entrance of moisture or other foreign matter after cutting.
  - 6. Proceed with patching after construction operations requiring cutting are complete.
- F. Patching: Patch construction by filling, repairing, refinishing, closing up, and similar operations following performance of other work. Patch with durable seams that are as invisible as practicable. Provide materials and comply with installation requirements specified in other Sections, where applicable.
  - 1. Inspection: Where feasible, test and inspect patched areas after completion to demonstrate physical integrity of installation.
  - 2. Exposed Finishes: Restore exposed finishes of patched areas and extend finish restoration into retained adjoining construction in a manner that will minimize evidence of patching and refinishing.
  - 3. Floors and Walls: Where walls or partitions that are removed extend one finished area into another, patch and repair floor and wall surfaces in the new space. Provide an even surface of uniform finish, color, texture, and appearance. Remove in-place floor and wall

- coverings and replace with new materials, if necessary, to achieve uniform color and appearance.
4. Ceilings: Patch, repair, or rehang in-place ceilings as necessary to provide an even-plane surface of uniform appearance.
  5. Exterior Building Enclosure: Patch components in a manner that restores enclosure to a weathertight condition and ensures thermal and moisture integrity of building enclosure.
- G. Cleaning: Clean areas and spaces where cutting and patching are performed. Remove paint, mortar, oils, putty, and similar materials from adjacent finished surfaces.

### 3.6 PROGRESS CLEANING

- A. General: Clean Project site and work areas daily, including common areas. Enforce requirements strictly. Dispose of materials lawfully.
1. Comply with requirements in NFPA 241 for removal of combustible waste materials and debris.
  2. Do not hold waste materials more than seven days during normal weather or three days if the temperature is expected to rise above 80 deg F.
  3. Containerize hazardous and unsanitary waste materials separately from other waste. Mark containers appropriately and dispose of legally, according to regulations.
    - a. Use containers intended for holding waste materials of type to be stored.
  4. Coordinate progress cleaning for joint-use areas where Contractor and other contractors are working concurrently.
- B. Site: Maintain Project site free of waste materials and debris.
- C. Work Areas: Clean areas where work is in progress to the level of cleanliness necessary for proper execution of the Work.
1. Remove liquid spills promptly.
  2. Where dust would impair proper execution of the Work, broom-clean or vacuum the entire work area, as appropriate.
- D. Installed Work: Keep installed work clean. Clean installed surfaces according to written instructions of manufacturer or fabricator of product installed, using only cleaning materials specifically recommended. If specific cleaning materials are not recommended, use cleaning materials that are not hazardous to health or property and that will not damage exposed surfaces.
- E. Concealed Spaces: Remove debris from concealed spaces before enclosing the space.
- F. Exposed Surfaces in Finished Areas: Clean exposed surfaces and protect as necessary to ensure freedom from damage and deterioration at time of Substantial Completion.
- G. Waste Disposal: Do not bury or burn waste materials on-site. Do not wash waste materials down sewers or into waterways. Comply with waste disposal requirements in Section 01 74 19 "Construction Waste Management and Disposal."
- H. During handling and installation, clean and protect construction in progress and adjoining materials already in place. Apply protective covering where required to ensure protection from damage or deterioration at Substantial Completion.

- I. Clean and provide maintenance on completed construction as frequently as necessary through the remainder of the construction period. Adjust and lubricate operable components to ensure operability without damaging effects.
- J. Limiting Exposures: Supervise construction operations to ensure that no part of the construction, completed or in progress, is subject to harmful, dangerous, damaging, or otherwise deleterious exposure during the construction period.

### 3.7 STARTING AND ADJUSTING

- A. Start equipment and operating components to confirm proper operation. Remove malfunctioning units, replace with new units, and retest.
- B. Adjust equipment for proper operation. Adjust operating components for proper operation without binding.
- C. Test each piece of equipment to verify proper operation. Test and adjust controls and safeties. Replace damaged and malfunctioning controls and equipment.

### 3.8 PROTECTION OF INSTALLED CONSTRUCTION

- A. Provide final protection and maintain conditions that ensure installed Work is without damage or deterioration at time of Substantial Completion.
- B. Protection of Existing Items: Provide protection and ensure that existing items to remain undisturbed by construction are maintained in condition that existed at commencement of the Work.
- C. Comply with manufacturer's written instructions for temperature and relative humidity.

**END OF SECTION 01 73 00**

## **SECTION 01 74 19 - CONSTRUCTION WASTE MANAGEMENT AND DISPOSAL**

### **PART 1 - GENERAL**

#### **1.1 SUMMARY**

- A. Section includes administrative and procedural requirements for the following:
  - 1. Salvaging nonhazardous construction waste.
  - 2. Recycling nonhazardous construction waste.
  - 3. Disposing of nonhazardous construction waste.
- B. Hazardous materials abatement is described in 'Exhibit D'. Contractor to abate and dispose of hazardous materials according to all applicable laws and ordinances.

#### **1.2 DEFINITIONS**

- A. Construction Waste: Building, structure, and site improvement materials and other solid waste resulting from construction, remodeling, renovation, or repair operations. Construction waste includes packaging.
- B. Demolition Waste: Building, structure, and site improvement materials resulting from demolition operations.
- C. Disposal: Removal of demolition or construction waste and subsequent salvage, sale, recycling, or deposit in landfill, incinerator acceptable to authorities having jurisdiction, or designated spoil areas on Owner's property.
- D. Recycle: Recovery of demolition or construction waste for subsequent processing in preparation for reuse.
- E. Salvage: Recovery of demolition or construction waste and subsequent sale or reuse in another facility.
- F. Salvage and Reuse: Recovery of demolition or construction waste and subsequent incorporation into the Work.

#### **1.3 ACTION SUBMITTALS**

- A. Waste Management Plan: Submit plan within 5 days of date established for the Notice to Proceed.
- B. Plan to be reviewed and accepted by the County Project Manager prior to implementation.

#### **1.4 INFORMATIONAL SUBMITTALS**

- A. Landfill and Incinerator Disposal Records: Indicate receipt and acceptance of waste by landfills and incinerator facilities licensed to accept them. Include manifests, weight tickets, receipts, and invoices.
- B. Statement of Refrigerant Recovery: Signed by refrigerant recovery technician responsible for recovering refrigerant, stating that all refrigerant that was present was recovered and that recovery was performed according to EPA regulations. Include name and address of technician and date refrigerant was recovered.



## PART 2 - PRODUCTS

### 2.1 NOT USED

## PART 3 - EXECUTION

### 3.1 PLAN IMPLEMENTATION

- A. General: Implement approved waste management plan. Provide handling, containers, storage, signage, transportation, and other items as required to implement waste management plan during the entire duration of the Contract.
- B. Training: Train workers, subcontractors, and suppliers on proper waste management procedures, as appropriate for the Work.
  - 1. Distribute waste management plan to everyone concerned within three days of submittal return.
  - 2. Distribute waste management plan to entities when they first begin work on-site. Review plan procedures and locations established for salvage, recycling, and disposal.
- C. Site Access and Temporary Controls: Conduct waste management operations to ensure minimum interference with roads, streets, walks, walkways, and other adjacent occupied and used facilities.
  - 1. Designate and label specific areas on Project site necessary for separating materials that are to be salvaged and recycled.
  - 2. Comply with Section 01 50 00 "Temporary Facilities and Controls" for controlling dust and dirt, environmental protection, and noise control.

### 3.2 RECYCLING CONSTRUCTION WASTE, GENERAL

- A. General: Recycle paper and beverage containers used by on-site workers.
- B. Recycling Incentives: Revenues, savings, rebates, tax credits, and other incentives received for recycling waste materials shall be shared equally by Owner and Contractor.
- C. Preparation of Waste: Prepare and maintain recyclable waste materials according to recycling or reuse facility requirements. Maintain materials free of dirt, adhesives, solvents, petroleum contamination, and other substances deleterious to the recycling process.
- D. Procedures: Separate recyclable waste from other waste materials, trash, and debris. Separate recyclable waste by type at Project site to the maximum extent practical according to approved construction waste management plan.
  - 1. Provide appropriately marked containers or bins for controlling recyclable waste until removed from Project site. Include list of acceptable and unacceptable materials at each container and bin.
    - a. Inspect containers and bins for contamination and remove contaminated materials if found.
  - 2. Stockpile processed materials on-site without intermixing with other materials. Place, grade, and shape stockpiles to drain surface water. Cover to prevent windblown dust.

3. Stockpile materials away from construction area. Do not store within drip line of remaining trees.
4. Store components off the ground and protect from the weather.
5. Remove recyclable waste from Owner's property and transport to recycling receiver or processor as often as required to prevent overfilling bins.

### 3.3 DISPOSAL OF WASTE

- A. General: Except for items or materials to be salvaged or recycled, remove waste materials from Project site and legally dispose of them in a landfill or incinerator acceptable to authorities having jurisdiction.
  1. Except as otherwise specified, do not allow waste materials that are to be disposed of accumulate on-site.
  2. Remove and transport debris in a manner that will prevent spillage on adjacent surfaces and areas.
- B. Burning: Do not burn waste materials.
- C. Disposal: Transport waste materials off Owner's property and legally dispose of them.

**END OF SECTION 01 74 19**

## **SECTION 01 77 00 - CLOSEOUT PROCEDURES**

### **PART 1 - GENERAL**

#### **1.1 SUMMARY**

- A. Section includes administrative and procedural requirements for contract closeout, including, but not limited to, the following:
  - 1. Inspection procedures.
  - 2. Substantial Completion procedures.
  - 3. Final completion procedures.
  - 4. Warranties.
  - 5. Instruction of Owner's personnel.
  - 6. Final cleaning.
  - 7. Repair of the Work.

#### **1.2 ACTION SUBMITTALS**

- A. Product Data: For each type of cleaning agent.
- B. Contractor's List of Incomplete Items: Initial submittal at Substantial Completion.
- C. Certified List of Incomplete Items: Final submittal at final completion.
- D. Closeout Schedule: Prior to Substantial Completion submit a schedule indicating tasks, timelines, and milestones for project closeout.

#### **1.3 CLOSEOUT SUBMITTALS**

- A. Certificates of Release: From authorities having jurisdiction.
- B. Certificate of Insurance: For continuing coverage.

#### **1.4 SUBSTANTIAL COMPLETION PROCEDURES**

- A. Contractor's List of Incomplete Items: Prepare and submit a list of items to be completed and corrected (Contractor's punch list), indicating the value of each item on the list and reasons why the Work is incomplete.
- B. Submittals Prior to Substantial Completion: Complete the following a minimum of 15 days prior to requesting inspection for determining date of Substantial Completion. List items below that are incomplete at time of request.
- C. Closeout Schedule: Provide a comprehensive schedule indicating milestones, tasks to be finished, work not complete along with plan to complete, and tentative dates for Owner/Architect inspection of completed work.
- D. Submittals Prior to Substantial Completion: Complete the following a minimum of 10 days prior to requesting inspection for determining date of Substantial Completion. List items below that are incomplete at time of request.

1. Certificates of Release: Obtain and submit releases from authorities having jurisdiction permitting Owner unrestricted use of the Work and access to services and utilities. Include occupancy permits, operating certificates, and similar releases.
  2. Submit closeout submittals specified in other Division 01 Sections, including project record documents, operation and maintenance manuals, damage or settlement surveys, property surveys, and similar final record information.
  3. Submit closeout submittals specified in individual Sections, including specific warranties, workmanship bonds, maintenance service agreements, final certifications, and similar documents.
  4. Submit maintenance material submittals specified in individual Sections, including tools, spare parts, extra materials, and similar items, and deliver to location designated by Architect. Label with manufacturer's name and model number.
  5. Submit testing, adjusting, and balancing records.
  6. Submit changeover information related to Owner's occupancy, use, operation, and maintenance.
- E. Procedures Prior to Substantial Completion: Complete the following a minimum of 10 days prior to requesting inspection for determining date of Substantial Completion. List items below that are incomplete at time of request.
1. Obtain and submit releases permitting Owner unrestricted use of the Work and access to services and utilities. Include occupancy permits, operating certificates, and similar releases.
  2. Advise Owner of pending insurance changeover requirements.
  3. Make final changeover of permanent locks and deliver keys to Owner. Advise Owner's personnel of changeover in security provisions.
  4. Complete startup and testing of systems and equipment.
  5. Submit test reports to Owner and Architect.
  6. Perform preventive maintenance on equipment used prior to Substantial Completion.
  7. Instruct Owner's personnel in operation, adjustment, and maintenance of products, equipment, and systems.
  8. Advise Owner of changeover in utility services.
  9. Participate with Owner in conducting inspection and walkthrough with local emergency responders.
  10. Terminate and remove temporary facilities from Project site, along with mockups, construction tools, and similar elements.
  11. Complete final cleaning requirements.
  12. Touch up paint and otherwise repair and restore marred exposed finishes to eliminate visual defects.
- F. Inspection: Submit a written request for inspection to determine Substantial Completion a minimum of 10 days prior to date the Work will be completed and ready for final inspection and tests. On receipt of request, Architect will either proceed with inspection or notify Contractor of unfulfilled requirements. Architect will prepare the Certificate of Substantial Completion after inspection or will notify Contractor of items, either on Contractor's list or additional items identified by Architect, that must be completed or corrected before certificate will be issued.
1. Reinspection: Request reinspection when the Work identified in previous inspections as incomplete is completed or corrected. Cost for reinspections after initial and on follow up reinspection may be back-charged to Contractor.
  2. Results of completed inspection will form the basis of requirements for Final Completion.

#### 1.5 FINAL COMPLETION PROCEDURES

- A. Submittals Prior to Final Completion: Before requesting final inspection for determining final completion, complete the following:

1. Certified List of Incomplete Items: Submit certified copy of Architect's Substantial Completion inspection list of items to be completed or corrected (punch list), endorsed and dated by Architect. Certified copy of the list shall state that each item has been completed or otherwise resolved for acceptance.
2. Certificate of Insurance: Submit evidence of final, continuing insurance coverage complying with insurance requirements.
3. Instruct Owner's personnel in operation, adjustment, and maintenance of equipment, and systems.

#### 1.6 LIST OF INCOMPLETE ITEMS (PUNCH LIST)

- A. Organization of List (Digital File): Include name and identification of each space and area affected by construction operations for incomplete items and items needing correction including, if necessary, areas disturbed by Contractor that are outside the limits of construction.
  1. Organize list of spaces in sequential order, starting with exterior areas first.
  2. Organize items applying to each space by major element, including categories for ceiling, individual walls, floors, equipment, and building systems.
  3. Include the following information at the top of each page:
    - a. Project Name
    - b. Date
    - c. Name of Architect
    - d. Name of Contractor
    - e. Page Number
  4. Submit list of incomplete items in one of the following formats:
    - a. MS Excel electronic file. Architect will return annotated file.
    - b. PDF electronic file. Architect will return annotated file.

#### 1.7 SUBMITTAL OF PROJECT WARRANTIES

- A. Warranty language to match County standard format. All guarantees and warranties shall follow the same language.
- B. Time of Submittal: Submit written warranties on request of Architect for designated portions of the Work where warranties are indicated to commence on dates other than date of Substantial Completion, or when delay in submittal of warranties might limit Owner's rights under warranty.
- C. Organize warranty documents into an orderly sequence based on the table of contents of Project Manual.
- D. Warranty Electronic File: Provide warranties and bonds in PDF format and bound hard copy binder. Assemble complete warranty and bond submittal package into a single electronic PDF file with bookmarks enabling navigation to each item. Provide bookmarked table of contents at beginning of document.
  1. Submit on digital media PDF format.
  2. Submit (1) 8 1/2 x 11 color copy in 3-ring binder, labeled. Include table of contents.
- E. Provide additional copies of each warranty to include in operation and maintenance manuals.

## PART 2 - PRODUCTS

### 2.1 MATERIALS

- A. Cleaning Agents: Use cleaning materials and agents recommended by manufacturer or fabricator of the surface to be cleaned. Do not use cleaning agents that are potentially hazardous to health or property or that might damage finished surfaces.

## PART 3 - EXECUTION

### 3.1 FINAL CLEANING

- A. General: Perform final cleaning. Conduct cleaning and waste-removal operations to comply with local laws and ordinances and Federal and local environmental and antipollution regulations.
- B. Cleaning: Employ experienced workers or professional cleaners for final cleaning. Clean each surface or unit to condition expected in an average commercial building cleaning and maintenance program. Comply with manufacturer's written instructions.
  - 1. Complete the following cleaning operations before requesting inspection for certification of Substantial Completion for entire Project or for a designated portion of Project:
    - a. Clean Project site, yard, and grounds, in areas disturbed by construction activities, including landscape development areas, of rubbish, waste material, litter, and other foreign substances.
    - b. Clean exposed exterior and interior hard-surfaced finishes to a dirt-free condition, free of stains, films, and similar foreign substances. Avoid disturbing natural weathering of exterior surfaces. Restore reflective surfaces to their original condition.
    - c. Remove debris and surface dust from limited access spaces, including roofs, plenums, shafts, trenches, equipment vaults, manholes, attics, and similar spaces.
    - d. Sweep concrete floors broom clean in unoccupied spaces.
    - e. Vacuum carpet and similar soft surfaces, removing debris and excess nap; clean according to manufacturer's recommendations if visible soil or stains remain.
    - f. Clean plumbing fixtures to a sanitary condition, free of stains, including stains resulting from water exposure.
    - g. Replace disposable air filters and clean permanent air filters. Clean exposed surfaces of diffusers, registers, and grills.
    - h. Clean light fixtures, lamps, globes, and reflectors to function with full efficiency.
    - i. Leave Project clean and ready for occupancy.
- C. Construction Waste Disposal: Comply with waste disposal requirements in Division 01 "Construction Waste Management and Disposal."

### 3.2 REPAIR OF THE WORK

- A. Complete repair and restoration operations, before requesting inspection for determination of Substantial Completion.
- B. Repair, or remove and replace, defective construction. Repairing includes replacing defective parts, refinishing damaged surfaces, touching up with matching materials, and properly adjusting operating equipment. Where damaged or worn items cannot be repaired or restored, provide replacements. Remove and replace operating components that cannot be repaired.

Restore damaged construction and permanent facilities used during construction to specified condition.

**END OF SECTION 01 77 00**

## **SECTION 01 78 23 - OPERATION AND MAINTENANCE DATA**

### **PART 1 - GENERAL**

#### **1.1 SUMMARY**

- A. Section includes administrative and procedural requirements for preparing operation and maintenance manuals, including the following:
  - 1. Operation and maintenance documentation directory manuals.
  - 2. Emergency manuals.
  - 3. Systems and equipment operation manuals.
  - 4. Systems and equipment maintenance manuals.
  - 5. Product maintenance manuals.

#### **1.2 CLOSEOUT SUBMITTALS**

- A. Submit operation and maintenance manuals indicated. Provide content for each manual as specified in individual Specification Sections, and as reviewed and approved at the time of Section submittals. Submit reviewed manual content formatted and organized as required by this Section.
  - 1. Architect will comment on whether content of operation and maintenance submittals is acceptable.
  - 2. Where applicable, clarify and update reviewed manual content to correspond to revisions and field conditions.
- B. Format: Submit operation and maintenance manuals in the following format:
  - 1. Submit on digital media acceptable to Architect. Enable reviewer comments on draft submittals.
- C. Final Manual Submittal: Submit each manual in final form prior to requesting inspection for Substantial Completion and at least 15 days before commencing demonstration and training. Architect will return copy with comments.
  - 1. Correct or revise each manual to comply with Architect's comments. Submit copies of each corrected manual within 15 days of receipt of Architect's comments and prior to commencing demonstration and training.
- D. An orientation date shall be set up to instruct the Owner's representative on the use of the operation and maintenance digital copy. A written report specifying times, dates, and names of personnel instructed shall be forwarded to the Owner's representative.
- E. Comply with Division 01 "Closeout Procedures" for schedule for submitting operation and maintenance documentation.

#### **1.3 FORMAT OF OPERATION AND MAINTENANCE MANUALS**

- A. Manuals, Electronic Files: Submit manuals in the form of a multiple file composite electronic PDF file for each manual type required.



1. Electronic Files: Use electronic files prepared by manufacturer where available. Where scanning of paper documents is required, configure scanned file for minimum readable file size.
2. Intuitive: The digital instruction manual shall be intuitive to navigate and find information.
3. File Names and Bookmarks: Bookmark individual documents based on file names. Name document files to correspond to system, subsystem, and equipment names used in manual directory and table of contents. Group documents for each system and subsystem into individual composite bookmarked files, then create composite manual, so that resulting bookmarks reflect the system, subsystem, and equipment names in a readily navigated file tree. Configure electronic manual to display bookmark panel on opening file.
4. Add digital copies shall be authored with Adobe Acrobat or Bluebeam (or other Owner approved PDF editing software) and shall not be limited to include the following:
5. Icons shall be located on the PDF plans to link test and balance reports and mechanical operation and maintenance information to the design drawings.
6. All information shall be printable on 8.5" x 11" plain paper with the design drawings and automatic temperature control drawings printable on 11" x 17" paper.
7. Linked information such that the user can key work search for information.
8. Provide a hyper-text alphabetical index of all equipment and building products as outlined elsewhere.
9. Use of multimedia formatting (text, pictures, graphics, and sound, etc.) will be used to make the information more accessible and understandable.
10. All documentation shall be converted to a 'locked' PDF format file.
11. Digital file shall include a General Information Index screen to direct the user to the portion of the data desired. This index screen will consist of four (4) major groups. The groups will include:
  - a. Contract Developers: This section is to include:
    - 1) Names of architects, engineers and contractors with address and telephone numbers.
  - b. Equipment List: This section to include:
    - 1) A job specific alphabetical list of all items supplied to the project with names of the manufacturer, Item description including the plan number, model number and local supplier with current address and telephone number.
  - c. Design drawings
  - d. Manufacturer's Operation and Maintenance Manuals:
12. Architectural section: This section to include:
  - a. Building products, applied materials and finishes: Include product data with catalog number, size, composition, color and texture designations. Provide information for reordering custom manufactured products. Data shall include, but not limited to, information on finishes, builders' hardware, etc.
  - b. Instruction for care and maintenance to include manufacturer's recommendation for cleaning agents and methods, precaution against detrimental agents and methods and recommended schedule for cleaning and maintenance.
13. Mechanical/Plumbing section:
  - a. A general description of the mechanical system.

- b. A step by step procedure to follow in putting each piece of mechanical equipment into operation.
  - c. Schematic control diagrams for each separate fans system, heating system, control panel, etc. Each diagram shall show locations of all control and operating components and devices.
  - d. Test and balance report
  - e. Valve tag schedule
  - f. All manufacturers operation and maintenance manual information
  - a. Maintenance instructions: This portion shall include a summary list of mechanical equipment requiring lubrication showing name of equipment and type and frequency of lubrication.
14. Special Maintenance Instructions to be summarized as follows:
- a. Preventative Maintenance Procedures
  - b. Seasonal start-up and shut-down maintenance
  - c. Periodical inspection requirements
15. Electrical section:
- a. Building products, applied materials and equipment: Include product data with catalog number. Provide information for reordering custom manufactured products.
  - b. Instruction for care and maintenance to include all manufacturers' recommendations.
16. Warranty section: Include all product warranties.
- B. Manuals, Paper Copies: Submit two (2) manuals in the form of hard-copy, bound and labeled volumes.
1. Binders: Heavy-duty, three-ring, vinyl-covered, loose-leaf binders, in thickness necessary to accommodate contents, sized to hold 8-1/2-by-11-inch paper; with clear plastic sleeve on spine to hold label describing contents and with pockets inside covers to hold folded oversize sheets.
  2. Drawings: Attach reinforced, punched binder tabs on drawings and bind with text.
    - a. If oversize drawings are necessary, fold drawings to same size as text pages and use as foldouts.
    - b. If drawings are too large to be used as foldouts, fold and place drawings in labeled envelopes and bind envelopes in rear of manual. At appropriate locations in manual, insert typewritten pages indicating drawing titles, descriptions of contents, and drawing locations.
- 1.4 REQUIREMENTS FOR EMERGENCY, OPERATION, AND MAINTENANCE MANUALS
- A. Organization of Manuals: Unless otherwise indicated, organize each manual into a separate section for each system and subsystem, and a separate section for each piece of equipment not part of a system. Each manual shall contain the following materials, in the order listed:
1. Title page.
  2. Table of contents.
  3. Manual contents.
- B. Title Page: Include the following information:

1. Subject matter included in manual.
  2. Name and address of Project.
  3. Name and address of Owner.
  4. Date of submittal.
  5. Name and contact information for Contractor.
  6. Name and contact information for Architect.
  7. Names and contact information for major consultants to the Architect that designed the systems contained in the manuals.
  8. Cross-reference to related systems in other operation and maintenance manuals.
- C. Table of Contents: List each product included in manual, identified by product name, indexed to the content of the volume, and cross-referenced to Specification Section number in Project Manual. The following table of contents should be common to all manuals and is based on ASI388 2 and Industry Best Practice.
1. Introduction and Scope:  
This is a basic introduction about the project, the builder, and the scope of work.
  2. Assets Record Information:  
Describing items of equipment, assets, or elements of the work.
  3. Maintenance Documents:  
The maintenance schedules and tasks required to maintain a piece of equipment/assets and hence prevent breakdown and/or meet compliance and manufacturer requirements.
  4. Operations:  
This section should be used to record relevant information on the operations for the system and/or assets. It should also include safety instructions, special tools, cleaning and operating instructions and trouble-shooting to assist in solving problems to prevent expensive call outs.
  5. Warranties and Certificates:  
Record specific warranty and certificate reference information. Important test results and performance criteria relating to operations should also be included.
  6. Spare Parts:  
Record any relevant information on the Spare Parts data for assets provided as part of the contract. It may also include information on spare parts suppliers.
  7. Help and Contact:  
This section should be used to record information to allow the Client to call for expert assistance in relation to the assets included in the project. This would include the main contractors, sub-contractors and suppliers.
  8. Drawings and References:  
This section allows you to attach/bind and or upload information like as-built plans, copies of specifications, complete product manuals and other documents relevant to the works and the O&M.
- D. Manual Contents: Organize into sets of manageable size. Arrange contents alphabetically by system, subsystem, and equipment. If possible, assemble instructions for subsystems, equipment, and components of one system into a single binder.
1. Information should be provided that covers the need of care, adjustment, maintenance, and operation of all equipment within the building, to include but not limited to: heating, air conditioning, ventilation, plumbing automatic temperature control systems, kitchen equipment, stage and theatrical equipment, electrical equipment, and building products requiring maintenance.
- E. Identification: In the documentation directory and in each operation and maintenance manual, identify each system, subsystem, and piece of equipment with same designation used in the Contract Documents. If no designation exists, assign a designation according to

ASHRAE Guideline 4, "Preparation of Operating and Maintenance Documentation for Building Systems."

#### 1.5 SYSTEMS AND EQUIPMENT OPERATION MANUALS

- A. Systems and Equipment Operation Manual: Assemble a complete set of data indicating operation of each system, subsystem, and piece of equipment not part of a system. Include information required for daily operation and management, operating standards, and routine and special operating procedures.
- B. Content: In addition to requirements in this Section, include operation data required in individual Specification Sections and the following information:
  - 1. System, subsystem, and equipment descriptions. Use designations for systems and equipment indicated on Contract Documents.
  - 2. Performance and design criteria if Contractor has delegated design responsibility.
  - 3. Operating standards.
  - 4. Operating procedures.
  - 5. Operating logs.
  - 6. Wiring diagrams.
  - 7. Control diagrams.
  - 8. Piped system diagrams.
  - 9. Precautions against improper use.
  - 10. License requirements including inspection and renewal dates.
- C. Descriptions: Include the following:
  - 1. Product name and model number. Use designations for products indicated on Contract Documents.
  - 2. Manufacturer's name.
  - 3. Equipment identification with serial number of each component.
  - 4. Equipment function.
  - 5. Operating characteristics.
  - 6. Limiting conditions.
  - 7. Performance curves.
  - 8. Engineering data and tests.
  - 9. Complete nomenclature and number of replacement parts.
- D. Operating Procedures: Include the following, as applicable:
  - 1. Startup procedures.
  - 2. Equipment or system break-in procedures.
  - 3. Routine and normal operating instructions.
  - 4. Regulation and control procedures.
  - 5. Instructions on stopping.
  - 6. Normal shutdown instructions.
  - 7. Seasonal and weekend operating instructions.
  - 8. Required sequences for electric or electronic systems.
  - 9. Special operating instructions and procedures.
- E. Systems and Equipment Controls: Describe the sequence of operation, and diagram controls as installed.
- F. Piped Systems: Diagram piping as installed, and identify color coding where required for identification.

1.6 SYSTEMS AND EQUIPMENT MAINTENANCE MANUALS

- A. Systems and Equipment Maintenance Manuals: Assemble a complete set of data indicating maintenance of each system, subsystem, and piece of equipment not part of a system. Include manufacturers' maintenance documentation, preventive maintenance procedures and frequency, repair procedures, wiring and systems diagrams, lists of spare parts, and warranty information.
- B. Content: For each system, subsystem, and piece of equipment not part of a system, include source information, manufacturers' maintenance documentation, maintenance procedures, maintenance and service schedules, spare parts list and source information, maintenance service contracts, and warranties and bonds, as described below.
- C. Manufacturers' Maintenance Documentation: Include the following information for each component part or piece of equipment:
  - 1. Standard maintenance instructions and bulletins; include only sheets pertinent to product or component installed. Mark each sheet to identify each product or component incorporated into the Work. If data include more than one item in a tabular format, identify each item using appropriate references from the Contract Documents. Identify data applicable to the Work and delete references to information not applicable.
    - a. Prepare supplementary text if manufacturers' standard printed data are not available and where the information is necessary for proper operation and maintenance of equipment or systems.
  - 2. Drawings, diagrams, and instructions required for maintenance, including disassembly and component removal, replacement, and assembly.
  - 3. Identification and nomenclature of parts and components.
  - 4. List of items recommended to be stocked as spare parts.
- D. Maintenance Procedures: Include the following information and items that detail essential maintenance procedures:
  - 1. Test and inspection instructions.
  - 2. Troubleshooting guide.
  - 3. Precautions against improper maintenance.
  - 4. Disassembly; component removal, repair, and replacement; and reassembly instructions.
  - 5. Aligning, adjusting, and checking instructions.
  - 6. Demonstration and training video recording, if available.
- E. Maintenance and Service Schedules: Include service and lubrication requirements, list of required lubricants for equipment, and separate schedules for preventive and routine maintenance and service with standard time allotment.
- F. Spare Parts List and Source Information: Include lists of replacement and repair parts, with parts identified and cross-referenced to manufacturers' maintenance documentation and local sources of maintenance materials and related services.
- G. Warranties and Bonds: Include copies of warranties and bonds and lists of circumstances and conditions that would affect validity of warranties or bonds.
  - 1. Include procedures to follow and required notifications for warranty claims.

- H. Drawings: Prepare drawings supplementing manufacturers' printed data to illustrate the relationship of component parts of equipment and systems and to illustrate control sequence and flow diagrams. Coordinate these drawings with information contained in record Drawings to ensure correct illustration of completed installation.

#### 1.7 PRODUCT MAINTENANCE MANUALS

- A. Product Maintenance Manual: Assemble a complete set of maintenance data indicating care and maintenance of each product, material, and finish incorporated into the Work.
- B. Content: Organize manual into a separate section for each product, material, and finish. Include source information, product information, maintenance procedures, repair materials and sources, and warranties and bonds, as described below.
- C. Product Information: Include the following, as applicable:
  - 1. Product name and model number.
  - 2. Manufacturer's name.
  - 3. Color, pattern, and texture.
  - 4. Material and chemical composition.
  - 5. Reordering information for specially manufactured products.
- D. Maintenance Procedures: Include manufacturer's written recommendations and the following:
  - 1. Inspection procedures.
  - 2. Types of cleaning agents to be used and methods of cleaning.
  - 3. List of cleaning agents and methods of cleaning detrimental to product.
  - 4. Schedule for routine cleaning and maintenance.
  - 5. Repair instructions.
- E. Repair Materials and Sources: Include lists of materials and local sources of materials and related services.
- F. Warranties and Bonds: Include copies of warranties and bonds and lists of circumstances and conditions that would affect validity of warranties or bonds.
  - 1. Include procedures to follow and required notifications for warranty claims.

PART 2 - PRODUCTS (Not Used)

PART 3 - EXECUTION (Not Used)

**END OF SECTION 01 78 23**

## SECTION 01 78 39 - PROJECT RECORD DOCUMENTS

### PART 1 - GENERAL

#### 1.1 SUMMARY

- A. Section includes administrative and procedural requirements for project record documents, including the following:
  - 1. Record Drawings.
  - 2. Record Specifications.

#### 1.2 CLOSEOUT SUBMITTALS

- A. Record Drawings: Comply with the following:
  - 1. Number of Copies: Submit copies of record Drawings as follows:
    - a. Initial Submittal:
      - 1) Submit PDF electronic files of scanned record prints and one of file prints.
    - b. Final Submittal:
      - 1) Submit PDF electronic files of scanned record prints and two (2) sets of prints.
      - 2) Print each drawing, whether or not changes and additional information were recorded.
- B. Record Specifications: Submit annotated PDF electronic files of Project's Specifications, including addenda and contract modifications.
- C. Record Logs: Submit final approved submittal log and approved submittals.

#### 1.3 RECORD DRAWINGS

- A. Record Prints: Maintain one set of blue or black line white prints of the Contract Drawings and Shop Drawings, incorporating new and revised drawings as modifications are issued. (Include CD with PDF files of each sheet and BIM drawings with each drawings digitally "bound" so all pertinent information displays when file is opened and each file drawn to meet the current version of the National BIM Standard).
  - 1. Preparation: Mark record prints to show the actual installation where installation varies from that shown originally. Require individual or entity who obtained record data, whether individual or entity is Installer, subcontractor, or similar entity, to provide information for preparation of corresponding marked-up record prints.
    - a. Give particular attention to information on concealed elements that would be difficult to identify or measure and record later.
    - b. Accurately record information in an acceptable drawing technique.
    - c. Record data as soon as possible after obtaining it.
    - d. Record and check the markup before enclosing concealed installations.

- e. Mark Contract Drawings or Shops Drawings, whichever is most capable of showing actual physical conditions, completely and accurately. Where Shop Drawings are marked, show cross reference on Contract Drawings.
2. Content: Types of items requiring marking include, but are not limited to, the following:
    - a. Dimensional changes to Drawings.
    - b. Revisions to details shown on Drawings.
    - c. Locations and depths of underground utilities.
    - d. Revisions to routing of piping and conduits.
    - e. Revisions to electrical circuitry.
    - f. Actual equipment locations.
    - g. Duct size and routing.
    - h. Locations of concealed internal utilities.
    - i. Changes made by Change Order or Construction Change Directive.
    - j. Changes made following Architect's written orders.
    - k. Details not on the original Contract Drawings.
    - l. Field records for variable and concealed conditions.
    - m. Record information on the Work that is shown only schematically.
  3. Mark the Contract Drawings and Shop Drawings completely and accurately. Use personnel proficient at recording graphic information in production of marked-up record prints.
  4. Mark record sets in PDF editing software with a color that is distinguishable or paper copy with erasable, red-colored pencil. Use other colors to distinguish between changes for different categories of the Work at same location.
  5. Mark important additional information that was either shown schematically or omitted from original Drawings.
- B. Note Construction Change Directive numbers, alternate numbers, Change Order numbers, and similar identification, where applicable. Record Digital Data Files: Immediately before inspection for Certificate of Substantial Completion, review marked-up record prints with Architect. When authorized, prepare a full set of corrected digital data files of the Contract Drawings, as follows:
1. Format: Annotated PDF electronic file with comment function enabled.
  2. Incorporate changes and additional information previously marked on record prints. Delete, redraw, and add details and notations where applicable.
  3. Refer instances of uncertainty to Architect for resolution.
  4. Architect will furnish Contractor with one set of digital data files of the Contract Drawings for use in recording information.
    - a. See Section 01 31 00 "Project Management and Coordination" for requirements related to use of Architect's digital data files.
    - b. Architect will provide data file layer information. Record markups in separate layers.
- C. Format: Identify and date each record Drawing; include the designation "PROJECT RECORD DRAWING" in a prominent location.
1. Format: Annotated PDF electronic file with comment function enabled.
  2. Identification: As follows:
    - a. Project name.
    - b. Date.
    - c. Designation "PROJECT RECORD DRAWINGS."



- d. Name of Architect.
- e. Name of Contractor.

#### 1.4 RECORD SPECIFICATIONS

- A. Preparation: Mark Specifications to indicate the actual product installation where installation varies from that indicated in Specifications, addenda, and contract modifications.
  - 1. Give particular attention to information on concealed products and installations that cannot be readily identified and recorded later.
  - 2. Mark copy with the proprietary name and model number of products, materials, and equipment furnished, including substitutions and product options selected.
  - 3. Record the name of manufacturer, supplier, Installer, and other information necessary to provide a record of selections made.
  - 4. Note related Change Orders, record Product Data, and record Drawings where applicable.
- B. Format: Submit record Specifications as annotated PDF electronic file.
- C. Miscellaneous Record Submittals: Assemble miscellaneous records required by other Specification Sections for miscellaneous record keeping and submittal in connection with actual performance of the Work. Bind or file miscellaneous records and identify each, ready for continued use and reference.

#### 1.5 MAINTENANCE OF RECORD DOCUMENTS

- A. Maintenance of Record Documents: Store record documents in the field office apart from the Contract Documents used for construction. Do not use project record documents for construction purposes. Maintain record documents in good order and in a clean, dry, legible condition, protected from deterioration and loss. Provide access to project record documents for Architect's reference during normal working hours.

PART 2 - PRODUCTS (not used)

PART 3 - EXECUTION (not used)

**END OF SECTION 01 78 39**

## **SECTION 01 79 00 - DEMONSTRATION AND TRAINING**

### **PART 1 - GENERAL**

#### **1.1 SUMMARY**

- A. Section includes administrative and procedural requirements for instructing Owner's personnel, including the following:
  - 1. Instruction in operation and maintenance of systems, subsystems, and equipment.
  - 2. Demonstration and training video recordings.

#### **1.2 INFORMATIONAL SUBMITTALS**

- A. Instruction Program: Submit outline of instructional program for demonstration and training, including a list of training modules and a schedule of proposed dates, times, length of instruction time, and instructors' names for each training module. Include learning objective and outline for each training module.
  - 1. Indicate proposed training modules using manufacturer-produced demonstration and training video recordings for systems, equipment, and products in lieu of video recording of live instructional module.

#### **1.3 CLOSEOUT SUBMITTALS**

- 1. At completion of training, submit complete training manual(s) for Owner's use prepared in same paper and PDF file format required for operation and maintenance manuals specified in Section 01 78 23 "Operation and Maintenance Data."

#### **1.4 QUALITY ASSURANCE**

- A. Facilitator Qualifications: A firm or individual experienced in training or educating maintenance personnel in a training program similar in content and extent to that indicated for this Project, and whose work has resulted in training or education with a record of successful learning performance.

#### **1.5 COORDINATION**

- A. Coordinate instruction schedule with Owner's operations. Adjust schedule as required to minimize disrupting Owner's operations and to ensure availability of Owner's personnel.
- B. Coordinate instructors, including providing notification of dates, times, length of instruction time, and course content.
- C. Coordinate content of training modules with content of approved emergency, operation, and maintenance manuals. Do not submit instruction program until operation and maintenance data have been reviewed and approved by Architect.

#### **1.6 INSTRUCTION PROGRAM**

- A. Program Structure: Develop an instruction program that includes individual and for equipment not part of a system, as required by individual Specification Sections.

- B. Training Modules: For each module, include instruction for the following as applicable to the system, equipment, or component:
1. Basis of System Design, Operational Requirements, and Criteria: Include the following:
    - a. System, subsystem, and equipment descriptions.
    - b. Performance and design criteria if Contractor is delegated design responsibility.
    - c. Operating standards.
    - d. Regulatory requirements.
    - e. Equipment function.
    - f. Operating characteristics.
    - g. Limiting conditions.
    - h. Performance curves.
  2. Documentation: Review the following items in detail:
    - a. Systems and equipment operation manuals.
    - b. Systems and equipment maintenance manuals.
    - c. Product maintenance manuals.
    - d. Project Record Documents.
    - e. Identification systems.
    - f. Warranties and bonds.
    - g. Maintenance service agreements and similar continuing commitments.
  3. Emergencies: Include the following, as applicable:
    - a. Instructions on meaning of warnings, trouble indications, and error messages.
    - b. Instructions on stopping.
    - c. Shutdown instructions for each type of emergency.
    - d. Operating instructions for conditions outside of normal operating limits.
    - e. Sequences for electric or electronic systems.
    - f. Special operating instructions and procedures.
  4. Operations: Include the following, as applicable:
    - a. Startup procedures.
    - b. Equipment or system break-in procedures.
    - c. Routine and normal operating instructions.
    - d. Regulation and control procedures.
    - e. Control sequences.
    - f. Safety procedures.
    - g. Instructions on stopping.
    - h. Normal shutdown instructions.
    - i. Operating procedures for emergencies.
    - j. Operating procedures for system, subsystem, or equipment failure.
    - k. Seasonal and weekend operating instructions.
    - l. Required sequences for electric or electronic systems.
    - m. Special operating instructions and procedures.
  5. Adjustments: Include the following:
    - a. Alignments.
    - b. Checking adjustments.
    - c. Noise and vibration adjustments.
    - d. Economy and efficiency adjustments.

6. Troubleshooting: Include the following:
  - a. Diagnostic instructions.
  - b. Test and inspection procedures.
  
7. Maintenance: Include the following:
  - a. Inspection procedures.
  - b. Types of cleaning agents to be used and methods of cleaning.
  - c. List of cleaning agents and methods of cleaning detrimental to product.
  - d. Procedures for routine cleaning.
  - e. Procedures for preventive maintenance.
  - f. Procedures for routine maintenance.
  - g. Instruction on use of special tools.
  
8. Repairs: Include the following:
  - a. Diagnosis instructions.
  - b. Repair instructions.
  - c. Disassembly; component removal, repair, and replacement; and reassembly instructions.
  - d. Instructions for identifying parts and components.
  - e. Review of spare parts needed for operation and maintenance.

#### 1.7 PREPARATION

- A. Assemble educational materials necessary for instruction, including documentation and training module. Assemble training modules into a training manual organized in coordination with requirements in Section 01 78 23 "Operation and Maintenance Data."
- B. Set up instructional equipment at instruction location.

#### 1.8 INSTRUCTION

- A. Facilitator: Engage a qualified facilitator to prepare instruction program and training modules, to coordinate instructors, and to coordinate between Contractor and Owner for number of participants, instruction times, and location.
- B. Engage qualified instructors to instruct Owner's personnel to adjust, operate, and maintain systems, subsystems, and equipment not part of a system.
- C. Scheduling: Provide instruction at mutually agreed-on times. For equipment that requires seasonal operation, provide similar instruction at start of each season.
  1. Schedule training with Owner with at least seven days' advance notice.
- D. Training Location and Reference Material: Conduct training on-site in the completed and fully operational facility using the actual equipment in-place. Conduct training using final operation and maintenance data submittals.
- E. Evaluation: At conclusion of each training module, assess and document each participant's mastery of module by use of a demonstration performance-based test.

- F. Cleanup: Collect used and leftover educational materials and give to Owner. Remove instructional equipment. Restore systems and equipment to condition existing before initial training use.

PART 2 - PRODUCTS (not used)

PART 3 - EXECUTION (not used)

**END OF SECTION 01 79 00**

## **SECTION 02 41 19 - SELECTIVE DEMOLITION**

### **PART 1 - GENERAL**

#### **1.1 SUMMARY**

- A. Section Includes:
  - 1. Demolition and removal of selected portions of building or structure.
  - 2. Salvage of existing items to be reused or recycled.

#### **1.2 DEFINITIONS**

- A. Remove: Detach items from existing construction and dispose of them off-site unless indicated to be salvaged or reinstalled.
- B. Remove and Salvage: Detach items from existing construction, in a manner to prevent damage, and deliver to Owner ready for reuse.
- C. Remove and Reinstall: Detach items from existing construction, in a manner to prevent damage, prepare for reuse, and reinstall where indicated.
- D. Existing to Remain: Leave existing items that are not to be removed and that are not otherwise indicated to be salvaged or reinstalled.
- E. Dismantle: To remove by disassembling or detaching an item from a surface, using gentle methods and equipment to prevent damage to the item and surfaces; disposing of items unless indicated to be salvaged or reinstalled.

#### **1.3 MATERIALS OWNERSHIP**

- A. Unless otherwise indicated, demolition waste becomes property of Contractor.
- B. Historic items, relics, antiques, and similar objects including, but not limited to, cornerstones and their contents, commemorative plaques and tablets, and other items of interest or value to Owner that may be uncovered during demolition remain the property of Owner.
  - 1. Carefully salvage in a manner to prevent damage and promptly return to Owner.

#### **1.4 PREINSTALLATION MEETINGS**

- A. Pre-demolition Conference: Conduct conference at Project site.
  - 1. Inspect and discuss condition of construction to be selectively demolished.
  - 2. Review structural load limitations of existing structure.
  - 3. Review requirements of work performed by other trades that rely on substrates exposed by selective demolition operations.
  - 4. Review areas where existing construction is to remain and requires protection.

#### **1.5 INFORMATIONAL SUBMITTALS**

- A. Pre-demolition Photographs or Video: Show existing conditions of adjoining construction, including finish surfaces that might be misconstrued as damage caused by demolition operations.

- B. Statement of Refrigerant Recovery: Signed by refrigerant recovery technician responsible for recovering refrigerant, stating that all refrigerant that was present was recovered and that recovery was performed according to EPA regulations. Include name and address of technician and date refrigerant was recovered.

#### 1.6 FIELD CONDITIONS

- A. Notify Architect of discrepancies between existing conditions and Drawings before proceeding with selective demolition.
- B. Hazardous Materials: Please refer to Exhibit D, Asbestos and Lead Report.
  - 1. If additional suspected hazardous materials are encountered, do not disturb; immediately notify Owner.
- C. Storage or sale of removed items or materials on-site is not permitted.
- D. Utility Service: Maintain existing utilities indicated to remain in service and protect them against damage during selective demolition operations.

### PART 2 - PRODUCTS

#### 2.1 PERFORMANCE REQUIREMENTS

- A. Regulatory Requirements: Comply with governing EPA notification regulations before beginning selective demolition. Comply with hauling and disposal regulations of authorities having jurisdiction.

### PART 3 - EXECUTION

#### 3.1 EXAMINATION

- A. Verify that utilities have been disconnected and capped before starting selective demolition operations.
- B. Review Project Record Documents of existing construction or other existing condition and hazardous material information provided by Owner. Owner does not guarantee that existing conditions are same as those indicated in Project Record Documents.
- C. Survey of Existing Conditions: Record existing conditions by use of measured drawings.
  - 1. Inventory and record the condition of items to be removed and salvaged. Provide photographs or video of conditions that might be misconstrued as damage caused by salvage operations.

#### 3.2 UTILITY SERVICES AND MECHANICAL/ELECTRICAL SYSTEMS

- A. Existing Services/Systems to Remain: Maintain services/systems indicated to remain and protect them against damage.
  - 1. Owner will arrange to shut off indicated services/systems when requested by Contractor.

### 3.3 PROTECTION

- A. Temporary Protection: Provide temporary barricades and other protection required to prevent injury to people and damage to adjacent buildings and facilities to remain.
  - 1. Provide temporary weather protection, during interval between selective demolition of existing construction on exterior surfaces and new construction, to prevent water leakage and damage to structure and interior areas.
  - 2. Protect walls, ceilings, floors, and other existing finish work that are to remain or that are exposed during selective demolition operations.
- B. Temporary Shoring: Design, provide, and maintain shoring, bracing, and structural supports as required to preserve stability and prevent movement, settlement, or collapse of construction and finishes to remain, and to prevent unexpected or uncontrolled movement or collapse of construction being demolished.
  - 1. Strengthen or add new supports when required during progress of selective demolition.

### 3.4 DISPOSAL OF DEMOLISHED MATERIALS

- A. Remove demolition waste materials from Project site and dispose of them in an EPA-approved construction and demolition waste landfill acceptable to authorities having jurisdiction. and recycle or dispose of them according to Section 01 74 19 "Construction Waste Management and Disposal."
  - 1. Do not allow demolished materials to accumulate on-site.
  - 2. Remove and transport debris in a manner that will prevent spillage on adjacent surfaces and areas.
- B. Burning: Do not burn demolished materials.

### 3.5 CLEANING

- A. Clean adjacent structures and improvements of dust, dirt, and debris caused by selective demolition operations. Return adjacent areas to condition existing before selective demolition operations began.

**END OF SECTION 02 41 19**



## **SECTION 03 30 00 - CAST-IN-PLACE CONCRETE**

### **PART 1 - GENERAL**

#### **1.1 SUMMARY**

- A. Section includes cast-in-place concrete, including formwork, reinforcement, concrete materials, mixture design, placement procedures, and finishes.

#### **1.2 ACTION SUBMITTALS**

- A. Product Data: For each type of product.
- B. Design Mixtures: For each concrete mixture.
- C. Steel Reinforcement Shop Drawings: Placing Drawings that detail fabrication, bending, and placement.

#### **1.3 INFORMATIONAL SUBMITTALS**

- A. Material certificates.
- B. Material test reports.
- C. Formwork Shop Drawings: Prepared by or under the supervision of a qualified professional engineer, detailing fabrication, assembly, and support of formwork.
- D. Floor surface flatness and levelness measurements indicating compliance with specified tolerances.

#### **1.4 QUALITY ASSURANCE**

- A. Manufacturer Qualifications: A firm experienced in manufacturing ready-mixed concrete products and that complies with ASTM C 94/C 94M requirements for production facilities and equipment.
  - 1. Manufacturer certified according to NRMCA's "Certification of Ready Mixed Concrete Production Facilities."
- B. Testing Agency Qualifications: An independent agency, acceptable to authorities having jurisdiction, qualified according to ASTM C 1077 and ASTM E 329 for testing indicated.

#### **1.5 FIELD CONDITIONS**

- A. Cold-Weather Placement: Comply with ACI 306.1.
  - 1. Do not use calcium chloride, salt, or other materials containing antifreeze agents or chemical accelerators unless otherwise specified and approved in mixture designs.
- B. Hot-Weather Placement: Comply with ACI 301 and ACI 305.1.

## PART 2 - PRODUCTS

### 2.1 CONCRETE, GENERAL

- A. ACI Publications: Comply with the following unless modified by requirements in the Contract Documents:
  - 1. ACI 301.
  - 2. ACI 117.

### 2.2 FORM-FACING MATERIALS

- A. Smooth-Formed Finished Concrete: Form-facing panels that provide continuous, true, and smooth concrete surfaces. Furnish in largest practicable sizes to minimize number of joints.
- B. Rough-Formed Finished Concrete: Plywood, lumber, metal, or another approved material. Provide lumber dressed on at least two edges and one side for tight fit.

### 2.3 STEEL REINFORCEMENT

- A. Reinforcing Bars: ASTM A 615/A 615M, Grade 60, deformed.
- B. Low-Alloy-Steel Reinforcing Bars: ASTM A 706/A 706M, deformed.
- C. Plain-Steel Welded-Wire Reinforcement: ASTM A 1064/A 1064M, plain, fabricated from as-drawn steel wire into flat sheets.
- D. Bar Supports: Bolsters, chairs, spacers, and other devices for spacing, supporting, and fastening reinforcing bars and welded-wire reinforcement in place. Manufacture bar supports from steel wire, plastic, or precast concrete according to CRSI's "Manual of Standard Practice."

### 2.4 CONCRETE MATERIALS

- A. Cementitious Materials:
  - 1. Portland Cement: ASTM C 150/C 150M, Type II/V, gray.
  - 2. Fly Ash: ASTM C 618, Class F.
- B. Normal-Weight Aggregates: ASTM C 33/C 33M, graded.
  - 1. Maximum Coarse-Aggregate Size: As indicated in the General Structural Notes.
  - 2. Fine Aggregate: Free of materials with deleterious reactivity to alkali in cement.
- C. Lightweight Aggregate: ASTM C 330/C 330M, 3/4-inch nominal maximum aggregate size.
- D. Air-Entraining Admixture: ASTM C 260/C 260M.
- E. Chemical Admixtures: Certified by manufacturer to be compatible with other admixtures and that do not contribute water-soluble chloride ions exceeding those permitted in hardened concrete. Do not use calcium chloride or admixtures containing calcium chloride.
  - 1. Water-Reducing Admixture: ASTM C 494/C 494M, Type A.
  - 2. Retarding Admixture: ASTM C 494/C 494M, Type B.
  - 3. Water-Reducing and Retarding Admixture: ASTM C 494/C 494M, Type D.
  - 4. High-Range, Water-Reducing Admixture: ASTM C 494/C 494M, Type F.

5. High-Range, Water-Reducing and Retarding Admixture: ASTM C 494/C 494M, Type G.
6. Plasticizing and Retarding Admixture: ASTM C 1017/C 1017M, Type II.

F. Water: ASTM C 94/C 94M and potable.

## 2.5 FIBER REINFORCEMENT

- A. Synthetic Micro-Fiber: Fibrillated polypropylene micro-fibers engineered and designed for use in concrete, complying with ASTM C 1116/C 1116M, Type III, **1/2 to 1-1/2 inches** long.

## 2.6 WATERSTOPS

- A. Chemically Resistant Flexible Waterstops: Thermoplastic elastomer rubber waterstops, for embedding in concrete to prevent passage of fluids through joints; resistant to oils, solvents, and chemicals. Factory fabricate corners, intersections, and directional changes.

1. Manufacturers: Subject to compliance with requirements provide one of the following:
  - a. Sika Worldwide. [www.usa.sika.com](http://www.usa.sika.com). Product: Westec Envirostop TPER Waterstop.
  - b. JP Specialties, Inc.. [www.jp-specialties.com](http://www.jp-specialties.com). Product: TPV Chemical Resistant Waterstop.

## 2.7 VAPOR RETARDERS

- A. Sheet Vapor Retarder: ASTM E 1745, Class A, except with maximum water-vapor permeance of 0.01 Perms as tested in accordance with mandatory conditioning tests per ASTM E1745 Section 7.1.. Include manufacturer's recommended adhesive or pressure-sensitive tape.

1. Manufacturers: Subject to compliance with requirements provide one of the following:
  - a. Stego Industries, LLC. Product: Stego Wrap Vapor Barrier
  - b. W.R. Meadows. [www.wrmeadows.com](http://www.wrmeadows.com).
  - c. Carlisle Synthetic Systems. [www.carlisesyntec.com](http://www.carlisesyntec.com).

- 1) Thickness: 15 mil. in all cases.

## 2.8 CURING MATERIALS

- A. Evaporation Retarder: Waterborne, monomolecular film forming, manufactured for application to fresh concrete.
- B. Absorptive Cover: AASHTO M 182, Class 2, burlap cloth made from jute or kenaf, weighing approximately 9 oz./sq. yd. when dry.
- C. Moisture-Retaining Cover: ASTM C 171, polyethylene film or white burlap-polyethylene sheet.
- D. Water: Potable.
- E. Clear, Waterborne, Membrane-Forming Curing Compound: ASTM C 309, Type 1, Class B, dissipating.
- F. Clear, Waterborne, Membrane-Forming Curing Compound: ASTM C 309, Type 1, Class B, non-dissipating, certified by curing compound manufacturer to not interfere with bonding of floor covering.

- G. Clear, Waterborne, Membrane-Forming Curing Compound: ASTM C 309, Type 1, Class B, 18 to 25 percent solids, non-dissipating, certified by curing compound manufacturer to not interfere with bonding of floor covering.
- H. Clear, Solvent-Borne, Membrane-Forming Curing and Sealing Compound: ASTM C 1315, Type 1, Class A.
- I. Clear, Waterborne, Membrane-Forming Curing and Sealing Compound: ASTM C 1315, Type 1, Class A.

## 2.9 RELATED MATERIALS

- A. Expansion- and Isolation-Joint-Filler Strips: ASTM D 1751, asphalt-saturated cellulosic fiber.

## 2.10 CONCRETE MIXTURES, GENERAL

- A. Prepare design mixtures for each type and strength of concrete, proportioned on the basis of laboratory trial mixture or field test data, or both, according to ACI 301.
- B. Cementitious Materials: Use fly ash, pozzolan, slag cement, and silica fume as needed to reduce the total amount of portland cement, which would otherwise be used, by not less than 40 percent.
- C. Admixtures: Use admixtures according to manufacturer's written instructions.
  - 1. Use water-reducing, high-range water-reducing or plasticizing admixture in concrete, as required, for placement and workability.
  - 2. Use water-reducing and -retarding admixture when required by high temperatures, low humidity, or other adverse placement conditions.
  - 3. Use water-reducing admixture in pumped concrete, concrete for heavy-use industrial slabs, concrete required to be watertight, and concrete with a w/c ratio below 0.50.

## 2.11 CONCRETE MIXTURES FOR BUILDING ELEMENTS

- A. Normal-Weight Concrete:
  - 1. Minimum Compressive Strength: As indicated in the General Structural Notes.
  - 2. Maximum W/C Ratio: As indicated in the General Structural Notes.
  - 3. Slump Limit: As indicated in the General Structural Notes.
  - 4. Air Content: As indicated in the General Structural Notes.
  - 5. Synthetic Micro-Fiber: Uniformly disperse in concrete mixture at manufacturer's recommended rate, as indicated in the General Structural Notes.
- B. Suspended Slabs: Lightweight concrete.
  - 1. Minimum Compressive Strength: As indicated in the General Structural Notes.
  - 2. Calculated Equilibrium Unit Weight: As indicated in the General Structural Notes.
  - 3. Slump Limit: As indicated in the General Structural Notes.
  - 4. Air Content: As indicated in the General Structural Notes.
  - 5. Synthetic Micro-Fiber: Uniformly disperse in concrete mixture at manufacturer's recommended rate, as indicated in the General Structural Notes.

## 2.12 FABRICATING REINFORCEMENT

- A. Fabricate steel reinforcement according to CRSI's "Manual of Standard Practice."

## 2.13 CONCRETE MIXING

- A. Ready-Mixed Concrete: Measure, batch, mix, and deliver concrete according to ASTM C 94/C 94M and ASTM C 1116/C 1116M, and furnish batch ticket information.
  - 1. When air temperature is between 85 and 90 deg F, reduce mixing and delivery time from 1-1/2 hours to 75 minutes; when air temperature is above 90 deg F, reduce mixing and delivery time to 60 minutes.

## PART 3 - EXECUTION

### 3.1 EMBEDDED ITEM INSTALLATION

- A. Place and secure anchorage devices and other embedded items required for adjoining work that is attached to or supported by cast-in-place concrete. Use setting drawings, templates, diagrams, instructions, and directions furnished with items to be embedded.

### 3.2 VAPOR-RETARDER INSTALLATION

- A. Sheet Vapor Retarders: Place, protect, and repair sheet vapor retarder according to ASTM E 1643 and manufacturer's written instructions.
  - 1. Lap joints 6 inches and seal with manufacturer's recommended tape.

### 3.3 STEEL REINFORCEMENT INSTALLATION

- A. General: Comply with CRSI's "Manual of Standard Practice" for fabricating, placing, and supporting reinforcement.
  - 1. Do not cut or puncture vapor retarder. Repair damage and reseal vapor retarder before placing concrete.

### 3.4 JOINTS

- A. General: Construct joints true to line with faces perpendicular to surface plane of concrete.
- B. Contraction Joints in Slabs-on-Grade: Form weakened-plane contraction joints, sectioning concrete into areas as indicated. Construct contraction joints for a depth equal to at least one-fourth of concrete thickness as follows:
  - 1. Grooved Joints: Form contraction joints after initial floating by grooving and finishing each edge of joint to a radius of 1/8 inch. Repeat grooving of contraction joints after applying surface finishes. Eliminate groover tool marks on concrete surfaces.
  - 2. Sawed Joints: Form contraction joints with power saws equipped with shatterproof abrasive or diamond-rimmed blades. Cut 1/8-inch- wide joints into concrete when cutting action does not tear, abrade, or otherwise damage surface and before concrete develops random contraction cracks.
- C. Isolation Joints in Slabs-on-Grade: After removing formwork, install joint-filler strips at slab junctions with vertical surfaces, such as column pedestals, foundation walls, grade beams, and other locations, as indicated.

### 3.5 WATERSTOP INSTALLATION

- A. Waterstops: Install in construction joints and at other locations indicated, according to manufacturer's written instructions.

### 3.6 CONCRETE PLACEMENT

- A. Before placing concrete, verify that installation of formwork, reinforcement, and embedded items is complete and that required inspections are completed.
- B. Deposit concrete continuously in one layer or in horizontal layers of such thickness that no new concrete is placed on concrete that has hardened enough to cause seams or planes of weakness. If a section cannot be placed continuously, provide construction joints as indicated. Deposit concrete to avoid segregation.
  - 1. Consolidate placed concrete with mechanical vibrating equipment according to ACI 301.
- C. Contractor shall utilize a washout tub during all concrete placing activities. Remove and recycle washout materials from Project site in a manner acceptable to authorities having jurisdiction. **WASHOUT SHALL NOT TAKE PLACE ON GRADE OR BE BURIED ON SITE.**

### 3.7 FINISHING FORMED SURFACES

- A. Rough-Formed Finish: As-cast concrete texture imparted by form-facing material with tie holes and defects repaired and patched. Remove fins and other projections that exceed specified limits on formed-surface irregularities.
  - 1. Apply to concrete surfaces not exposed to public view.
- B. Smooth-Formed Finish: As-cast concrete texture imparted by form-facing material, arranged in an orderly and symmetrical manner with a minimum of seams. Repair and patch tie holes and defects. Remove fins and other projections that exceed specified limits on formed-surface irregularities.
  - 1. Apply to concrete surfaces exposed to public view,.
- C. Related Unformed Surfaces: At tops of walls, horizontal offsets, and similar unformed surfaces adjacent to formed surfaces, strike off smooth and finish with a texture matching adjacent formed surfaces. Continue final surface treatment of formed surfaces uniformly across adjacent unformed surfaces unless otherwise indicated.

### 3.8 FINISHING FLOORS AND SLABS

- A. General: Comply with ACI 302.1R recommendations for screeding, restraightening, and finishing operations for concrete surfaces. Do not wet concrete surfaces.
- B. Float Finish: Consolidate surface with power-driven floats or by hand floating if area is small or inaccessible to power-driven floats. Restraighten, cut down high spots, and fill low spots. Repeat float passes and restraightening until surface is left with a uniform, smooth, granular texture.
  - 1. Apply float finish to surfaces to receive trowel finish and to be covered with fluid-applied or sheet waterproofing, built-up or membrane roofing, or sand-bed terrazzo.

- C. Trowel Finish: After applying float finish, apply first troweling and consolidate concrete by hand or power-driven trowel. Continue troweling passes and restraighen until surface is free of trowel marks and uniform in texture and appearance. Grind smooth any surface defects that would telegraph through applied coatings or floor coverings.
  - 1. Apply a trowel finish to surfaces exposed to view or to be covered with resilient flooring, carpet, ceramic, or quarry tile set over a cleavage membrane, paint, or another thin-film-finish coating system.
  - 2. Finish and measure surface, so gap at any point between concrete surface and an unlevelled, freestanding, 10-ft.- long straightedge resting on two high spots and placed anywhere on the surface does not exceed 1/8 inch.
- D. Trowel and Fine-Broom Finish: Apply a first trowel finish to surfaces where ceramic or quarry tile is to be installed by either thickset or thinset method. While concrete is still plastic, slightly scarify surface with a fine broom.
  - 1. Comply with flatness and levelness tolerances for trowel-finished floor surfaces.
- E. Broom Finish: Apply a broom finish to exterior concrete platforms, steps, ramps, and elsewhere as indicated.
  - 1. Immediately after float finishing, slightly roughen trafficked surface by brooming with fiber-bristle broom perpendicular to main traffic route. Coordinate required final finish with Architect before application.

### 3.9 CONCRETE PROTECTING AND CURING

- A. General: Protect freshly placed concrete from premature drying and excessive cold or hot temperatures. Comply with ACI 306.1 for cold-weather protection and ACI 305.1 for hot-weather protection during curing.
- B. Evaporation Retarder: Apply evaporation retarder to unformed concrete surfaces if hot, dry, or windy conditions cause moisture loss approaching 0.2 lb/sq. ft. x h before and during finishing operations. Apply according to manufacturer's written instructions after placing, screeding, and bull floating or darbying concrete, but before float finishing.
- C. Formed Surfaces: Cure formed concrete surfaces, including underside of beams, supported slabs, and other similar surfaces. If forms remain during curing period, moist cure after loosening forms. If removing forms before end of curing period, continue curing for remainder of curing period.
- D. Cure concrete according to ACI 308.1, by one or a combination of the following methods:
  - 1. Moisture Curing: Keep surfaces continuously moist for not less than seven days.
  - 2. Moisture-Retaining-Cover Curing: Cover concrete surfaces with moisture-retaining cover for curing concrete, placed in widest practicable width, with sides and ends lapped at least 12 inches, and sealed by waterproof tape or adhesive. Cure for not less than seven days. Immediately repair any holes or tears during curing period, using cover material and waterproof tape.
  - 3. Curing Compound: Apply uniformly in continuous operation by power spray or roller according to manufacturer's written instructions. Recoat areas subjected to heavy rainfall within three hours after initial application. Maintain continuity of coating and repair damage during curing period.

- a. Removal: After curing period has elapsed, remove curing compound without damaging concrete surfaces by method recommended by curing compound manufacturer unless manufacturer certifies curing compound does not interfere with bonding of floor covering used on Project.
  
  - 4. Curing and Sealing Compound: Apply uniformly to floors and slabs indicated in a continuous operation by power spray or roller according to manufacturer's written instructions. Recoat areas subjected to heavy rainfall within three hours after initial application. Repeat process 24 hours later and apply a second coat. Maintain continuity of coating and repair damage during curing period.
- 3.10 CONCRETE SURFACE REPAIRS
- A. Defective Concrete: Repair and patch defective areas when approved by Architect. Remove and replace concrete that cannot be repaired and patched to Architect's approval.
- 3.11 FIELD QUALITY CONTROL
- A. Special Inspections: Owner will engage a special inspector and qualified testing and inspecting agency to perform field tests and inspections and prepare test reports.

**END OF SECTION 03 30 00**



## **SECTION 05 50 00 – METAL FABRICATIONS**

### **PART 1 - GENERAL**

#### **1.1 RELATED DOCUMENTS**

- A. Drawings and general provisions of the Contract, including General Conditions and Division 1 Specification Sections, apply to this Section.

#### **1.2 SUMMARY**

- A. This Section includes metal fabrications and related work as shown and specified.

#### **1.3 SUBMITTALS**

- A. Product Data: Submit manufacturer's specifications and data for review.
- B. Shop Drawings: Submit manufacture installation details, including fastenings, for review.

#### **1.4 QUALITY ASSURANCE**

- A. Welding: Performed by certified welders per AWS and CBC.
- B. Installer Qualifications: Minimum of 3 years of experience on similar work; knowledge and understanding of standards referenced herein; skill necessary to perform in compliance with this specification. Installers failing to demonstrate the required experience, knowledge, or skill shall be removed from the project.

#### **1.5 GUARANTEE**

- A. Provide in required form for a period of 1 year from date of acceptance by Owner.

### **PART 2 - PRODUCTS**

#### **2.1 FERROUS METALS**

- A. Steel Plates, Shapes, and Bars: ASTM A 36.
- B. Steel Pipe: ASTM A 53, Type E or S, Grade B.
- C. Steel Tube: Cold-formed per ASTM 500 or hot-formed per ASTM A501

#### **2.2 FASTENERS**

- A. General: Hexagon head bolts, hex nuts, screws, washers, and other fastenings necessary for proper erection of work. Hot dipped galvanized steel fastenings for exterior steel work.
- B. Exposed in Finished Surfaces: Tamperproof countersunk Phillips flat head screws, unless shown otherwise; match adjacent surface finish.

#### **2.3 SHIPS LADDER**

- A. Acceptable Products:
  - 1. Ships Ladder, as manufactured by Royalite Manufacturing; 1055 Terminal Way, San Carlos, 94070.

- a. OSHA compliant.
- b. Extruded aluminum, 6063-T5 alloy.
- c. Wall brackets bent aluminum 2" x 3/16" strap, including diagonal angle braces.
- d. Integral landing platform, aluminum 6063-T5 alloy, with 2"x1" 'treads' placed adjacent to each other to form platform.

- B. Alternate Products: Proposed equals are subject to substitution process per Section 01 25 00 – SUBSTITUTION PROCEDURES.

## 2.4 VERTICAL LADDER

- A. Acceptable Products:

- 1. Vertical Ladder, as manufactured by Royalite Manufacturing; 1055 Terminal Way, San Carlos, 94070.

- a. OSHA compliant.
- b. Extruded aluminum, 6063-T5 alloy.
- c. Wall brackets bent aluminum 2" x 3/16" strap, including diagonal angle braces.
- d. Lift-up rail extensions aluminum 6063-T5 alloy, 77" long, manually extended/retracted.

- B. Alternate Products: Proposed equals are subject to substitution process per Section 01 25 00 – SUBSTITUTION PROCEDURES.

- C. Per ASTM C-1107, consisting of non-metallic aggregate, cement, water reducing and plasticizing additives, capable of developing a minimum compressive strength of 7,000 psi at 28 days.

## 2.5 PLASTIC CEMENT

- A. FS SS-C-153, Type 1, bituminous asphalt base.

## 2.6 PRIMER

- A. General: Fast-curing, lead- and chromate-free, corrosion inhibitive, modified-alkyd primer.
- B. Primer: Certified to pass 200 hours salt spray test per ASTM D2247 and 500 hour humidity test per ASTM B117.
- C. Paint Top Coats: Verify compatibility. Refer to Section 09 90 00 - PAINTING AND COATING.

## 2.7 FABRICATION

- A. Shop Assembly: Preassemble items in the shop to greatest extent possible.
- B. General: Provide materials with smooth, flat surfaces, unless otherwise indicated. For metal fabrications exposed to view in the completed Work, provide materials without seam marks, roller marks, rolled trade names, or blemishes.
- C. Miter corners and edges unless otherwise shown. Make members true to length so assembling may be done without fillers. Bends, twists, open joints in finished members, or projecting edges or corners at connections will not be permitted. Miter, cope, and block carefully to produce tight hairline joints. Provide lugs, clips, connections, bolts, and fastenings necessary to complete fabrication.
- D. Exposed Steel: Comply with ASIC Architecturally Exposed Structural Steel fabrication requirements.

- E. Fabricating with Galvanized Material: Fabrications to be painted or concealed may be fabricated from galvanized materials. Treat all welds, cut ends, and any surfaces where galvanizing has been removed or damage with specified repair compound to the specified thickness.
- F. Galvanized Final Finish: Fabrications for galvanized final finish shall be fabricated out of ungalvanized material per ASTM A385 – “Providing High Quality Zinc Coatings” and hot-dip galvanized in one finished piece after fabrication. Fabrications to have galvanized final finish shall not be field welded.
- G. Welding: Use sequence welding to minimize distortion and heat stresses. Weld by shielded electric arc process per AWS. Use continuous welding along entire area of contact, unless detailed otherwise. Grind all welds smooth on exposed surfaces. Spot welding not permitted on exposed surfaces.

## PART 3 - EXECUTION

### 3.1 EXAMINATION

- A. Examine conditions of work in place before beginning work; report defects.
- B. Proceed with installation only after unsatisfactory conditions have been corrected.
- C. Take field measurements; report variance between plan and field dimensions.

### 3.2 INSTALLATION

- A. Install in conformance with referenced standards, manufacturer's written directions, as shown, and as specified.
- B. Cutting, Fitting, and Placement: Perform cutting, drilling, and fitting required carefully for installing metal fabrications. Fit work at job before finishing. No burning in field permitted.
- C. Set metal fabrications accurately in location, alignment, and elevation; with edges and surfaces level, plumb, true, and free of rack; and measured from established lines and levels.
- D. Drill holes for fasteners to exact diameter as recommended by fastener manufacturer. Oversized holes or holes not properly located that produce misalignment of fastener will be rejected.
- E. Fit exposed connections accurately together to form hairline joints. Do not weld, cut, or abrade surfaces of exterior units that have been hot-dip galvanized after fabrication and are for bolted or screwed field connections.
- F. Replace, or repair parts damaged or injured during erection in an acceptable manner.
- G. Galvanizing: Treat areas damaged during fabrication or erection with specified repair compound to restore zinc coating to a minimum of 2 ounces per square foot.

### 3.3 ADJUSTING AND CLEANING

- A. Keep premises free from accumulation of waste and debris. At completion of installation remove surplus materials and debris.
- B. At completion clean exposed surfaces in a manner that will not damage finish.
- C. Field Touch-up: Touch-up damaged surfaces and field welds of steel, scheduled to be painted, per SSPC standards.

- D. Touchup Painting: Cleaning and touchup painting of field welds, bolted connections, and abraded areas of shop paint are specified in Section 09 90 00 - PAINTING AND COATING.

**END SECTION 05 50 00**

## SECTION 06 10 00 – ROUGH CARPENTRY

### PART 1 - GENERAL

#### 1.1 RELATED DOCUMENTS

- A. Drawings and general provisions of the Contract, including General Conditions and Division 1 Specification Sections, apply to this Section.

#### 1.2 SUMMARY

- A. This Section includes rough carpentry and related work as shown and specified.

#### 1.3 SUBMITTALS

- A. Product Data: Manufacturer's specifications, data, and installation instructions for review.
  - 1. Submit manufacturers' product data for hardwood plywood, particleboard and medium density fiberboard composite wood products indicating maximum formaldehyde emissions in parts per million.
  - 2. Submit manufacturer's product data for all wood preservatives and treatments, adhesives, and caulks, indicating VOC content in grams per liter.
- B. Certificates:
  - 1. Pressure Treatment: Submit mill certificate verifying compliance as specified, for each shipment received, in addition to a stamp on each piece of lumber, from an approved independent inspecting agency operating under the overview of the ALSC.
  - 2. Lumber Grades: Where lumber and plywood is exposed to view and clear finished, provide Certificates in lieu of grade stamping and trademarks.

#### 1.4 QUALITY ASSURANCE

- A. Reference Standards:
  - 1. American Forest and Paper Association (AFPA): National Design Specification for Wood Construction.
  - 2. American Lumber Standards Committee (ALSC): Grading Standards.
  - 3. American National Standards Institute (ANSI):
    - a. Mat-Formed Wood Particleboard: ANSI A208.
    - b. Basic Hardboard: ANSI/AHA A135.4.
  - 4. American Plywood Association (APA): Standard Grading Rules.
  - 5. American Wood Preservers Association (AWPA): Standard U1, preservative and fire retardant treatments.
  - 6. National Institute of Standards and Technology (NIST): PS-20.
  - 7. Redwood Inspection Service (RIS): Standard Specifications for Grades of California Redwood Lumber.
  - 8. West Coast Lumber Inspection Bureau (WCLIB): Standard Grading Rules No. 17.
  - 9. Western Wood Products Association (WWPA): Western Lumber Grading Rules.

- B. All wood preservatives and treatments, adhesives, and caulks shall comply with the VOC limits set forth in the California Green Building Standards Code, Title 24 Part 11.
- C. All hardwood plywood, particleboard and medium density fiberboard composite wood products shall meet the formaldehyde limits set forth in the California Green Building Standards Code, Title 24 Part 11.
- D. Composite wood and agrifiber, and site and shop-applied adhesives and binders for composite wood and agrifiber products used on the interior of the building such as particleboard and plywood shall contain no urea formaldehyde resin.

## PART 2 - PRODUCTS

### 2.1 GRADING

- A. General: NIST PS-20 and applicable lumberman's association rules, as approved by authority having jurisdiction, under which each lumber species is produced.
- B. Grade Marking:
  - 1. Lumber: CBC Standard 23-1; each piece of lumber, factory marked with official grade mark of grading agency or independent agency operating under the overview of ALSC.
  - 2. Plywood: CBC Standard 23-2 and PS 1; each panel legibly identified for type, grade and species by APA grade mark.

### 2.2 LUMBER

- A. General: Sizes dressed as shown, surfaced 4 sides; 19% maximum moisture content; air or kiln dried. Lumber 3 inches nominal and thicker shall be free of Heart Center.
- B. Lumber Grades:
  - 1. General: Douglas Fir-Larch; up to 4 inch nominal thickness - No. 2; over 4 inch nominal thickness - No. 1.
  - 2. Sills:
    - a. General: Pressure treated Douglas Fir-Larch – No. 1 or better; AWPB marked.
    - b. Non-bearing Stud Walls: Redwood, where specifically shown.
  - 3. Posts, Beams and Stringers: Douglas Fir-Larch - Select Structural.
  - 4. Miscellaneous Framing:
    - a. Douglas Fir-Larch: Blocking, nailers, furring, bridging and stripping; No. 2 grade.
    - b. Redwood: Where specifically shown; Foundation Grade, unless otherwise noted.
- C. Plywood: U.S. Product Standard PS 1
  - 1. Comply with formaldehyde limits set forth above.
- D. Wood Treatment:
  - 1. General: Factory applied treatment, unless noted otherwise.
  - 2. Comply with VOC limits set forth above.
  - 3. Acceptable Manufacturers:

- a. California Cascade-Woodland, Inc.
  - b. J. H. Baxter Company.
4. Alternate Manufacturers: Proposed equals are subject to substitution process per Section 01 25 00 – SUBSTITUTION PROCEDURES.
  5. Fire Retardant: AWWA Standard U1, Exterior Type, chemically treated and pressure impregnated; capable of providing a maximum flame spread rating of 25.
  6. Wood Preservative
    - a. Pressure Treatment: AWWA Standard U1 using water borne preservative.
    - b. Surface Application: Clear type.
    - c. Comply with VOC limits set forth above.
- E. Gypsum Sheathing: ASTM C1396, ASTM C 1177/1177M.
1. Subject to compliance with requirements use one of the following products by manufacturers listed below:
    - a. CertainTeed: Glasroc Sheathing.
    - b. Georgia-Pacific: DensGlass Sheathing.
    - c. USG: Securock Brand Glass-Mat Sheathing.
    - d. Other manufacturers as approved by Architect prior to bidding, refer to specification section 01 25 00 Substitution Procedures.
  2. Type and Thickness: Type X, 5/8 inch thick.
- F. Plywood Sheathing: U.S. Product Standard PS 1-95 for soft plywood. Struct 1 at walls; CDX at roofs unless noted otherwise.

## 2.3 ROUGH HARDWARE

- A. Hangers, Clamps, Straps and Anchors:
1. General: Types as shown.
  2. Acceptable Manufacturers:
    - a. Simpson Strong Tie Co., Inc.
    - b. USP Structural Connectors, a Gibraltar Industries Company.
  3. Alternate Manufacturers: Comparable products with current ICC-ES approval and equal or greater rated load capacity, manufactured by USP Lumber Connectors. Proposed equals are subject to substitution process per 01 25 00 – SUBSTITUTION PROCEDURES. Submit ICC-ES Report approval for review for all alternate products.
- B. Special Fabrications: Refer Section 05 50 00 - METAL FABRICATIONS.
- C. Fasteners:
1. Nails: ASTM F1667, common wire; hot dip galvanized for pressure preservative treated work, exterior work, and as shown. Gun nails shall be full size with full heads and are subject to approval of architect. Box or sinker nails are not permitted.
  2. Bolts and Nuts: ASTM A307, Grade A, including supplementary requirement S1; galvanized for exterior work.
  3. Wood Screws: ANSI/ASME Standard B18.6.1; galvanized for exterior work.
  4. Lag Screws: ANSI/ASME Standard B18.2.1; galvanized for exterior work.

5. Washers: Malleable iron or standard cut steel with steel lock washer; galvanized at exterior work.
6. Specialty Fasteners: Galvanized.
  - a. Acceptable Manufacturers:
    - 1) Hilti, Inc.
    - 2) ITW Ramset/Readhead.
7. Alternate Manufacturers: Comparable products with current ICC-ES approval and equal or greater rated load capacity; proposed equals are subject to substitution process per Section 01 25 00 – SUBSTITUTION PROCEDURES.
8. Expansion Bolts: Kwik Bolt III at masonry; Kwik Bolt TZ at concrete.
9. Concrete Screws: Kwik Con II.
10. Powder Actuated Fasteners: Hilti shot pin XU; 2 7/8 inch length.

## 2.4 ADHESIVE

- A. General: Per APA-AFG-01 for plywood floor sheathing.
  1. Comply with VOC and formaldehyde limits set forth above.
- B. Acceptable Products: EnerBond SF, as manufactured by Wind-lock.
- C. Alternate Products: No known equals; proposed equals are subject to substitution process per Section 01 25 00 – SUBSTITUTION PROCEDURES.

## 2.5 BUILDING PAPER

- A. General: ASTM D226, 15 pound asphalt saturated felt.

## 2.6 CAULKING

- A. Refer to Section 07 92 00 - JOINT SEALERS.

## PART 3 - EXECUTION

### 3.1 EXAMINATION

- A. Examine conditions of work in place before beginning work; report defects.
- B. Proceed with installation only after unsatisfactory conditions have been corrected.

### 3.2 PREPARATION

- A. Coordinate work specified elsewhere that affects the work of this Section.
- B. Take field measurements; report variance between plan and field dimensions.
- C. Protection:
  1. Security and Safety: Provide temporary protection and enclosures as required.
  2. Temporary Bracing: Provide bracing adequate to keep structure stable, plumb and in line; keep in place until permanent framing is completed. Provide bracing capable of



supporting loads imposed by stockpiled material, erection equipment and other loads, during construction.

### 3.3 GENERAL ERECTION

- A. Coordinate placement of anchors, inserts, etc., in concrete and masonry. Establish locations, lines, levels and provide cutting, patching and fitting as required to accommodate built-in Work specified in other Sections.
- B. Use new lumber; re-use not permitted unless authorized in writing by the Architect. Select lumber in a manner that allowable knots and obvious minor defects do not interfere with placement of bolts, nailing or structural connections.
- C. Layout as shown; set plates, nailing blocks, anchors, grounds, etc., as required.
- D. Brush apply 2 coats of preservative treatment on site-sawn cuts in pressure treated lumber. Allow preservative to dry prior to erecting members.
- E. Fasteners:
  - 1. Nails: Per CBC Table 2304.9.1 unless otherwise noted. Space groups of nails no closer together than required penetration and not closer than one half of the required penetration from cut ends or edges of lumber. Prevent splitting due to nailing drill holes for nails no more than 0.75 diameter of nail. Where nails of normal length may penetrate through exposed work, use nail of specified diameter and shorter length. Use of nailing gun is subject to visual approval of the engineer, Architect and inspector. Gun nail heads shall not penetrate the face ply of structural panels. Gun nails shall not cause wood members to split or otherwise compromise the integrity of connections.
  - 2. Bolts and Nuts: Use steel pieces as template for location of holes; drill holes 1/16-inch larger than diameter of bolts; tighten nuts or rods and bolts at time of installation. Re-tighten before covering up and just before final inspection and acceptance of the work; at exposed work, cut protruding bolt ends off to within 1/8-inch of nut and file off burrs.
  - 3. Washers: Install at bolts, nuts or lag screws bearing on wood; not required under heads of carriage bolts.
  - 4. Screws:
    - a. General: Hammering or driving in place not permitted. Use soap to lubricate screw threads, if required.
    - b. Lag Screws: Drill holes of same diameter and depth as shank; drill holes for threaded portion of screw no larger than 3/4 shank diameter.
    - c. Wood Screws: Drill lead holes for shank and threaded portions, hole diameter 7/8 of shank or thread root diameter.
  - 5. Powder Actuated Fasteners:
    - a. General: Install where shown or required; **DO NOT** install in structural connections required to carry computed stresses.
    - b. Application: Per Article 28, Powder-Actuated Tools, Paragraph 1685, of Title 8, CCR.

### 3.4 INSTALLATION

- A. General:

1. Structural Members:
    - a. General: Set level and plumb, in correct position; place horizontal members level, with crown side up.
  2. Framing Members: Construct full length without splices; notching permitted only with approval of the Architect.
  3. Blocking:
    - a. General: Provide as shown and where necessary to obtain required lines and levels in finished surface and to provide solid nailing. Secure blocking plumb and rigid; use wood shims wherever necessary to form true and even plane for finish materials.
    - b. Firestopping: Provide per CBC at interior and exterior walls at intersection with floor, ceiling and roof, and at all hollow concealed spaces. Install minimum 2-inch nominal material by width of enclosed spaces within partition in continuous row to prevent vertical and horizontal draft. Maximum concealed air space of 10'-0" in any direction.
    - c. Backing: Provide blocking within walls where anchorage is required for equipment and accessories shown.
  4. Recessed Fixtures: Frame openings for panel boxes and other equipment, as required for fixtures provided.
- B. Wall Framing:
1. General: Wood studs as shown; frame openings with multiple studs at sides and headers as shown.
  2. Plates: Provide continuous sole plates, pressure treated when in contact with concrete, and double top plates. Lap top plate splices 4'-0" minimum; lap at wall corners and intersections.
  3. Studs: Continuous lengths without splices; provide solid blocking at plywood joints.
  4. Framing for Piping: Provide proper clearances; furr partitions as required. At pipe 1-1/2 inches diameter, or less, set pipe in center of plate using neat holes; no notching allowed. Holes in plates less than 5-1/2 inches in width, not allowed.
  5. Headers: Continuous members as shown.
  6. Corner Bracing: Continuous members as shown.
  7. Sheathing:
    - a. Orientation: Secure with long dimension parallel to studs, with joints located over studs or solid blocking and end joints staggered; nailing as shown.
    - b. Joints: Minimum 1/16-inch space at end joints and 1/8-inch at edge joints.
    - c. Penetrations: Penetration of structurally required sheathing to accommodate electrical or mechanical requirements must be approved in writing by the Architect.
    - d. Gypsum Sheathing: As Shown.
- C. Roof Framing:
1. General: New openings in existing roof to be framed as noted on the Drawings.
- D. Miscellaneous Framing:

1. General: Provide nailers, backing, and stripping as necessary to obtain required lines and levels in finished surface. Secure plumb and rigid; use wood shims where required. Provide backing required for wall or ceiling hung fixtures and equipment.
2. Building Paper:
  - a. General: Apply where shown, with 2-inch horizontal laps and 6-inch vertical laps at joints and corners. Repair damaged paper before installation of finish material.
  - b. Paper: Use 3/8-inch head galvanized nails spaced adequately to hold paper in place, without buckling.
3. Caulking:
  - a. Energy Compliance: Apply during framing operations as required by CBC.
  - b. Sound-Rated Partitions: Install sole plates on double bead of acoustical sealant.
  - c. Thresholds: Set in full bed.
4. Mechanical and Electrical: Provide curbs, backing and blocking, as required for mechanical and electrical fixtures and equipment.

### **3.5 TOLERANCES**

- A. Install to allow application of subsequent finish materials within specified tolerances.

### **3.6 CLEANING**

- A. Keep premises free from accumulation of waste and debris. At completion of installation remove surplus materials and debris.
- B. At completion clean exposed surfaces in a manner that will not damage finish.

**END SECTION 06 10 00**

## **SECTION 06 20 13 - EXTERIOR FINISH CARPENTRY**

### **PART 1 - GENERAL**

#### **1.1 SUMMARY**

- A. Section Includes:
  - 1. Exterior wood trim.
  - 2. Plywood siding.

#### **1.2 ACTION SUBMITTALS**

- A. Product Data: For each type of process and factory-fabricated product. Indicate component materials, dimensions, profiles, textures, and colors and include construction and application details.
  - 1. Include data for wood-preservative treatment from chemical-treatment manufacturer and certification by treating plant that treated materials comply with requirements. Indicate type of preservative used and net amount of preservative retained. Include chemical-treatment manufacturer's written instructions for finishing treated material.
  - 2. For products receiving a waterborne treatment, include statement that moisture content of treated materials was reduced before shipment to Project site to levels specified.

#### **1.3 DELIVERY, STORAGE, AND HANDLING**

- A. Stack lumber, plywood, and other panels flat with spacers between each bundle to provide air circulation. Protect materials from weather by covering with waterproof sheeting, securely anchored. Provide for air circulation around stacks and under coverings.

#### **1.4 FIELD CONDITIONS**

- A. Weather Limitations: Proceed with installation only when existing and forecast weather conditions permit work to be performed and at least one coat of specified finish can be applied without exposure to rain, snow, or dampness.
- B. Do not install finish carpentry materials that are wet, moisture damaged, or mold damaged.

### **PART 2 - PRODUCTS**

#### **2.1 MATERIALS, GENERAL**

- A. Lumber: DOC PS 20 and applicable rules of grading agencies indicated.
- B. Factory mark each piece of lumber with grade stamp of inspection agency, indicating grade, species, moisture content at time of surfacing, and mill.
- C. Softwood Plywood: DOC PS 1.
- D. Hardboard: ANSI A135.4.

## 2.2 WOOD-PRESERVATIVE-TREATED MATERIALS

- A. Water-Repellent Preservative Treatment by Non-pressure Process: AWPA N1; dip, spray, flood, or vacuum-pressure treatment.
  - 1. Preservative Chemicals: 3-iodo-2-propynyl butyl carbamate (IPBC), combined with an insecticide containing chloropyrifos (CPF).
  - 2. Use chemical formulations that do not bleed through or otherwise adversely affect finishes. Do not use colorants in solution to distinguish treated material from untreated material.
- B. Preservative Treatment by Pressure Process: AWPA U1; Use Category UC3a.
  - 1. Kiln dry lumber and plywood after treatment to a maximum moisture content of 19 and 18 percent, respectively.
  - 2. Preservative Chemicals: Acceptable to authorities having jurisdiction and containing no arsenic or chromium.
  - 3. Do not use material that is warped or does not comply with requirements for untreated material.
  - 4. Mark lumber with treatment-quality mark of an inspection agency approved by the American Lumber Standard Committee's Board of Review.
  - 5. Mark plywood with appropriate classification marking of an inspection agency acceptable to authorities having jurisdiction.

## 2.3 EXTERIOR TRIM

- A. Lumber Trim for Painted Finish:
  - 1. Species and Grade: Redwood, **[Clear] [Grade B]**; RIS.
  - 2. Maximum Moisture Content: 19 percent.
  - 3. Finger Jointing: Not allowed.
  - 4. Face Surface: Match existing finish surface.

## 2.4 PLYWOOD SIDING

- A. Plywood Type: APA-rated siding, pressure-preservative treated, in panel sizes indicated.
  - 1. Face Grade: 303-**OC, OL**, NR, SR: To match existing, field verify.
- B. Thickness: To match existing.
- C. Face Species: Redwood.
- D. Pattern: To match existing.
- E. Surface: To match existing.

## 2.5 MISCELLANEOUS MATERIALS

- A. Fasteners for Exterior Finish Carpentry: Provide nails or screws, in sufficient length to penetrate not less than 1-1/2 inches into wood substrate.
  - 1. For face-fastening siding, provide ringed-shank siding nails.
  - 2. For redwood, provide stainless-steel.

3. For prefinished items, provide matching prefinished aluminum fasteners where face fastening is required.
  4. For pressure-preservative-treated wood, provide hot-dip galvanized-steel fasteners.
  5. For applications not otherwise indicated, provide stainless steel, hot-dip galvanized-steel or aluminum fasteners, as appropriate for condition.
- B. Flashing: Comply with requirements in Section 07 62 00 "Sheet Metal Flashing and Trim" for flashing materials installed in exterior finish carpentry.
1. Horizontal Joint Flashing for Panel Siding: Preformed, galvanized-steel, Z-shaped flashing.
- C. Sealants: Latex, complying with ASTM C 834 Grade NF and applicable requirements in Section 07 92 00 "Joint Sealants" and recommended by sealant and substrate manufacturers for intended application.

### PART 3 - EXECUTION

#### 3.1 EXAMINATION

- A. Examine substrates, with Installer present, for compliance with requirements for installation tolerances and other conditions affecting performance of the Work.
- B. Examine finish carpentry materials before installation. Reject materials that are wet, moisture damaged, and mold damaged.
- C. Proceed with installation only after unsatisfactory conditions have been corrected.

#### 3.2 PREPARATION

- A. Clean substrates of projections and substances detrimental to application.
- B. Prime lumber and moldings to be painted, including both faces and edges, unless factory primed. Cut to required lengths and prime ends. Comply with requirements in Section 09 91 13 "Exterior Painting."

#### 3.3 INSTALLATION, GENERAL

- A. Do not use materials that are unsound, warped, improperly treated or finished, inadequately seasoned, or too small to fabricate with proper jointing arrangements.
  1. Do not use manufactured units with defective surfaces, sizes, or patterns.
- B. Install exterior finish carpentry level, plumb, true, and aligned with adjacent materials. Use concealed shims where necessary for alignment.
  1. Scribe and cut exterior finish carpentry to fit adjoining work. Refinish and seal cuts as recommended by manufacturer.
  2. Coordinate exterior finish carpentry with materials and systems in or adjacent to it. Provide cutouts for mechanical and electrical items that penetrate exterior finish carpentry.

### 3.4 STANDING AND RUNNING TRIM INSTALLATION

- A. Install trim with minimum number of joints as is practical, using full-length pieces from maximum lengths of lumber available. Do not use pieces less than 24 inches long, except where necessary.
  - 1. Use scarf joints for end-to-end joints.
  - 2. Stagger end joints in adjacent and related members.
- B. Fit exterior joints to exclude water. Cope at returns and miter at corners to produce tight-fitting joints, with full-surface contact throughout length of joint. Plane backs of casings to provide uniform thickness across joints, where necessary for alignment.
- C. Where face fastening is unavoidable, countersink fasteners, fill surface flush, and sand unless otherwise indicated.

### 3.5 SIDING INSTALLATION

- A. Install siding to comply with manufacturer's written instructions.
- B. Plywood Siding: Install panels with edges over framing or blocking. Nail at 6 inches o.c. at panel perimeter and 12 inches o.c. at intermediate supports unless manufacturer recommends closer spacing. Leave 1/16-inch gap between adjacent panels and 1/8-inch gap at perimeter, openings, and horizontal joints unless otherwise recommended by panel manufacturer.
  - 1. Seal butt joints at inside and outside corners and at trim locations.
  - 2. Install continuous metal flashing at horizontal panel joints.
  - 3. Apply battens and corner trim to match existing. Countersink nail heads, fill flush, and sand filler.
  - 4. Conceal fasteners to greatest practical extent by countersinking and filling, or by placing behind battens. Do not nail through overlapping pieces.
- C. Flashing: Install metal flashing as indicated on Drawings and as recommended by siding manufacturer.
- D. Finish: Apply finish within two weeks of installation.

### 3.6 ADJUSTING

- A. Replace exterior finish carpentry that is damaged or does not comply with requirements. Exterior finish carpentry may be repaired or refinished if work complies with requirements and shows no evidence of repair or refinishing. Adjust joinery for uniform appearance.

### 3.7 CLEANING

- A. Clean exterior finish carpentry on exposed and semi-exposed surfaces. Touch up factory-applied finishes to restore damaged or soiled areas.

### 3.8 PROTECTION

- A. Protect installed products from damage from weather and other causes during construction.
- B. Remove and replace finish carpentry materials that are wet, moisture damaged, and mold damaged.

1. Indications that materials are wet or moisture damaged include, but are not limited to, discoloration, sagging, or irregular shape.
2. Indications that materials are mold damaged include, but are not limited to, fuzzy or splotchy surface contamination and discoloration.

**END OF SECTION 06 20 13**



## SECTION 07 2100 - THERMAL INSULATION

### PART 1 - GENERAL

#### 1.1 SUMMARY

- A. Section Includes:
  - 1. Glass-fiber blanket (Interior walls).
  - 2. Glass-fiber blanket, kraft faced (Exterior walls and Roof).
  - 3. Mineral-wool blanket (Misc. locations).

#### 1.2 ACTION SUBMITTALS

- A. Product Data: For each type of product.

#### 1.3 INFORMATIONAL SUBMITTALS

- A. Product test reports.

### PART 2 - PRODUCTS

#### 2.1 GLASS-FIBER BLANKET

- A. Glass-Fiber Blanket, Unfaced: ASTM C 665, Type I; with maximum flame-spread and smoke-developed indexes of 25 and 50, respectively, per ASTM E 84; passing ASTM E 136 for combustion characteristics.
- B. Glass-Fiber Blanket, Kraft Faced: ASTM C 665, Type II (nonreflective faced), Class A (faced surface with a flame-spread index of 25 or less); Category 1 (membrane is a vapor barrier).
- C. Glass-Fiber Blanket, Kraft Faced: ASTM C 665, Type II (nonreflective faced), Class C (faced surface not rated for flame propagation); Category 1 (membrane is a vapor barrier).

#### 2.2 MINERAL-WOOL BLANKETS

- A. Mineral-Wool Blanket, Unfaced: ASTM C 665, Type I (blankets without membrane facing); consisting of fibers; with maximum flame-spread and smoke-developed indexes of 25 and 50, respectively, per ASTM E 84; passing ASTM E 136 for combustion characteristics.
  - 1. To be used at sound rated walls

#### 2.3 ACCESSORIES

- A. Insulation for Miscellaneous Voids:
  - 1. Glass-Fiber Insulation: ASTM C 764, Type II, loose fill; with maximum flame-spread and smoke-developed indexes of 5, per ASTM E 84.
  - 2. Spray Polyurethane Foam Insulation: ASTM C 1029, Type II, closed cell, with maximum flame-spread and smoke-developed indexes of 75 and 450, respectively, per ASTM E 84.
- B. Insulation Anchors, Spindles, and Standoffs: As recommended by manufacturer.

- C. Adhesive for Bonding Insulation: Product compatible with insulation and air and water barrier materials, and with demonstrated capability to bond insulation securely to substrates without damaging insulation and substrates.
- D. Polypropylene scrim kraft facing to cover insulation at areas with no finished ceiling:
  - 1. White, commercial grade 3-way fiberglass natural kraft paper (PSK) scrim, 50gsm.

### PART 3 - EXECUTION

#### 3.1 INSTALLATION, GENERAL

- A. Comply with insulation manufacturer's written instructions applicable to products and applications.
- B. Install insulation that is undamaged, dry, and unsoiled and that has not been left exposed to ice, rain, or snow at any time.
- C. Extend insulation to envelop entire area to be insulated. Fit tightly around obstructions and fill voids with insulation. Remove projections that interfere with placement.
- D. Provide sizes to fit applications and selected from manufacturer's standard thicknesses, widths, and lengths. Apply single layer of insulation units unless multiple layers are otherwise shown or required to make up total thickness or to achieve R-value.

#### 3.2 INSTALLATION OF INSULATION IN FRAMED CONSTRUCTION

- A. Blanket Insulation: Install in cavities formed by framing members according to the following requirements:
  - 1. Use insulation widths and lengths that fill the cavities formed by framing members. If more than one length is required to fill the cavities, provide lengths that will produce a snug fit between ends.
  - 2. Place insulation in cavities formed by framing members to produce a friction fit between edges of insulation and adjoining framing members.
  - 3. Maintain 3-inch clearance of insulation around recessed lighting fixtures not rated for or protected from contact with insulation.
  - 4. For wood-framed construction, install blankets according to ASTM C 1320 and as follows:
    - a. With faced blankets having stapling flanges, lap blanket flange over flange of adjacent blanket to maintain continuity of vapor retarder once finish material is installed over it.
- B. Miscellaneous Voids: Install insulation in miscellaneous voids and cavity spaces where required to prevent gaps in insulation using the following materials:
  - 1. Glass-Fiber Insulation: Compact to approximately 40 percent of normal maximum volume equaling a density of approximately 2.5 lb/cu. ft.
- C. Scrim facing: Install PSK scrim at areas with no finished ceiling. Fasten to underside of roof framing per manufactures' recommendations.
  - 1. Fasteners to match scrim (white).
  - 2. Scrim to be installed taut, with no sags or wrinkles.
  - 3. End cuts to be square, clean, and tight to end walls/materials.

4. Carefully cut around brackets/hangers as required, and repair cuts per manufacturer's recommendation.

### 3.3 INSTALLATION OF INSULATION IN CEILINGS FOR SOUND ATTENUATION

- A. Where glass-fiber blankets are indicated for sound attenuation above ceilings, install blanket insulation over entire ceiling area in thicknesses required to achieve indicated performance characteristics.

### 3.4 PROTECTION

- A. Protect installed insulation and vapor retarders from damage due to harmful weather exposures, physical abuse, and other causes. Provide temporary coverings or enclosures where insulation is subject to abuse and cannot be concealed and protected by permanent construction immediately after installation.
- B. Protect work of other trades against damage from paint activities. Correct damage by cleaning, repairing, replacing, and repaint as acceptable to Architect.

**END OF SECTION 07 2100**

## **SECTION 07 25 00 - WEATHER BARRIERS**

### **PART 1 - GENERAL**

#### **1.1 RELATED DOCUMENTS**

- A. Drawings and general provisions of the Contract, including General and Supplementary Conditions and Division 01 Specification Sections, apply to this Section.

#### **1.2 SUMMARY**

- A. Section Includes:
  - 1. Building paper.
  - 2. Flexible flashing.
  - 3. Drainage material.

#### **1.3 ACTION SUBMITTALS**

- A. Product Data: For each type of product.
  - 1. For building wrap, include data on air and water-vapor permeance based on testing according to referenced standards.

#### **1.4 INFORMATIONAL SUBMITTALS**

- A. Evaluation Reports: For water-resistive barrier and flexible flashing, from ICC-ES.

### **PART 2 - PRODUCTS**

#### **2.1 WATER-RESISTIVE BARRIER**

- A. Building Paper: ASTM D 226, Type 1 (No. 15 asphalt-saturated organic felt), unperforated.
- B. Building Paper: Water-vapor-permeable, asphalt-saturated kraft building paper that complies with ICC-ES AC38, Grade D; except with water-resistance rating not less than 1 hour.

#### **2.2 FLEXIBLE FLASHING**

- A. Butyl Rubber Flashing: Composite, self-adhesive, flashing product consisting of a pliable, butyl rubber compound, bonded to a high-density polyethylene film, aluminum foil, or spun bonded polyolefin to produce an overall thickness of not less than 0.025 inch.
  - 1. Flame Propagation Test: Materials and construction shall be as tested according to NFPA 285.
- B. Rubberized-Asphalt Flashing: Composite, self-adhesive, flashing product consisting of a pliable, rubberized-asphalt compound, bonded to a high-density polyethylene film, aluminum foil, or spun bonded polyolefin to produce an overall thickness of not less than 0.025 inch.
  - 1. Flame Propagation Test: Materials and construction shall be as tested according to NFPA 285.

- C. Primer for Flexible Flashing: Product recommended in writing by flexible flashing manufacturer for substrate.
- D. Nails and Staples: Product recommended in writing by flexible flashing manufacturer and complying with ASTM F 1667.

### PART 3 - EXECUTION

#### 3.1 WATER-RESISTIVE BARRIER INSTALLATION

- A. Cover exposed exterior surface of sheathing with water-resistive barrier securely fastened to framing immediately after sheathing is installed.
- B. Cover sheathing with water-resistive barrier as follows:
  - 1. Cut back barrier 1/2 inch on each side of the break in supporting members at expansion- or control-joint locations.
  - 2. Apply barrier to cover vertical flashing with a minimum 4-inch overlap unless otherwise indicated.
- C. Building Paper: Apply horizontally with a 2-inch overlap and a 6-inch end lap; fasten to sheathing with galvanized staples or roofing nails.

#### 3.2 FLEXIBLE FLASHING INSTALLATION

- A. Apply flexible flashing where indicated to comply with manufacturer's written instructions.
  - 1. Prime substrates as recommended by flashing manufacturer.
  - 2. Lap seams and junctures with other materials at least 4 inches except that at flashing flanges of other construction, laps need not exceed flange width.
  - 3. Lap flashing over water-resistive barrier at bottom and sides of openings.
  - 4. Lap water-resistive barrier over flashing at heads of openings.
  - 5. After flashing has been applied, roll surfaces with a hard rubber or metal roller to ensure that flashing is completely adhered to substrates.

**END OF SECTION 07 25 00**

## **SECTION 07 51 13 - BUILT-UP ASPHALT ROOFING**

### **PART 1 - GENERAL**

#### **1.1 RELATED DOCUMENTS**

- A. Drawings and general provisions of the Contract, including General and Supplementary Conditions and Division 01 Specification Sections, apply to this Section.

#### **1.2 SUMMARY**

##### **A. Section Includes:**

1. Built-up asphalt roofing.
2. Vapor retarder.
3. Roof insulation.

##### **B. Related Requirements:**

1. Section 07 21 00 "Thermal Insulation" for insulation beneath the roof deck.
2. Section 07 62 00 "Sheet Metal Flashing and Trim" for metal roof flashings and counterflashings.
3. Section 07 92 00 "Joint Sealants" for joint sealants, joint fillers, and joint preparation.

#### **1.3 DEFINITIONS**

- A. Roofing Terminology: Definitions in ASTM D 1079 and glossary of NRCA's "The NRCA Roofing and Waterproofing Manual" apply to Work of this Section.

#### **1.4 ACTION SUBMITTALS**

- A. Product Data: For each type of product.

- B. Samples for Verification: For the following products:

1. Cap sheet, of color required to match existing roofing.
2. Flashing sheet, of color required to match existing conditions.

#### **1.5 INFORMATIONAL SUBMITTALS**

- A. Qualification Data: For Installer and manufacturer.

- B. Manufacturer Certificates: Signed by roofing manufacturer certifying that built-up roofing complies with requirements specified in "Performance Requirements" Article.

1. Submit evidence of compliance with performance requirements.

- C. Product Test Reports: For components of built-up roofing, for tests performed by manufacturer and witnessed by a qualified testing agency.

- D. Research/Evaluation Reports: For components of built-up roofing, from ICC-ES.

- E. Field quality-control reports.

- F. Sample Warranties: For manufacturer's special warranties.

1.6 CLOSEOUT SUBMITTALS

- A. Maintenance Data: For built-up roofing to include in maintenance manuals.

1.7 QUALITY ASSURANCE

- A. Manufacturer Qualifications: A qualified manufacturer that is **UL** for built-up roofing identical to that used for this Project.
- B. Installer Qualifications: A qualified firm that is approved, authorized, or licensed by built-up roofing manufacturer to install manufacturer's product and that is eligible to receive manufacturer's special warranty.

1.8 DELIVERY, STORAGE, AND HANDLING

- A. Deliver roofing materials to Project site in original containers with seals unbroken and labeled with manufacturer's name, product brand name and type, date of manufacture, approval or listing agency markings, and directions for storing and mixing with other components.
- B. Store liquid materials in their original undamaged containers in a clean, dry, protected location and within the temperature range required by roofing manufacturer. Protect stored liquid material from direct sunlight.
  - 1. Discard and legally dispose of liquid material that cannot be applied within its stated shelf life.
- C. Protect roof insulation materials from physical damage and from deterioration by sunlight, moisture, soiling, and other sources. Store in a dry location. Comply with insulation manufacturer's written instructions for handling, storing, and protecting during installation.
- D. Handle and store roofing materials, and place equipment in a manner to avoid permanent deflection of deck.

1.9 FIELD CONDITIONS

- A. Weather Limitations: Proceed with installation only when existing and forecasted weather conditions permit roofing to be installed according to manufacturer's written instructions and warranty requirements.

1.10 WARRANTY

- A. Warranty: Manufacturer agrees to repair or replace components of built-up roofing that fail in materials or workmanship within specified warranty period.
  - 1. Warranty includes built-up roofing membrane, base flashings, , and other components of built-up roofing.
  - 2. Warranty Period: 2 years from date of Substantial Completion.

## PART 2 - PRODUCTS

### 2.1 MANUFACTURERS

- A. Source Limitations: Obtain components for built-up roofing from same manufacturer as built-up roofing or manufacturer approved by built-up roofing manufacturer.

### 2.2 PERFORMANCE REQUIREMENTS

- A. General Performance: Installed built-up roofing and base flashings shall withstand specified uplift pressures, thermally induced movement, and exposure to weather without failure due to defective manufacture, fabrication, installation, or other defects in construction. Built-up roofing and base flashings shall remain watertight.
  - 1. Accelerated Weathering: Roofing system shall withstand 2000 hours of exposure when tested according to ASTM G 152, ASTM G 154, or ASTM G 155.
  - 2. Impact Resistance: Roofing system shall resist impact damage when tested according to ASTM D 3746 or ASTM D4272.
- B. Material Compatibility: Roofing materials shall be compatible with one another and adjacent materials under conditions of service and application required, as demonstrated by built-up roofing manufacturer based on testing and field experience.
- C. Exterior Fire-Test Exposure: ASTM E 108 or UL 790, Class A; for application and roof slopes indicated; testing by a qualified testing agency. Identify products with appropriate markings of applicable testing agency.

### 2.3 ROOFING MEMBRANE SHEET MATERIALS

- A. Sheathing Paper: Red-rosin type, minimum 3 lb/100 sq. ft..
- B. Base Sheet: Match existing roofing
- C. Base Sheet: ASTM D 2626, asphalt-saturated and -coated organic felt, dusted with fine mineral surfacing on both sides.
- D. Ply Sheet: Match existing.
- E. Cap Sheet: Match existing.

### 2.4 ASPHALT MATERIALS

- A. Asphalt Primer: ASTM D 41/D 41M.
- B. Roofing Asphalt: ASTM D 312, match existing.

### 2.5 AUXILIARY BUILT-UP ROOFING MATERIALS

- A. General: Auxiliary materials recommended by roofing manufacturer for intended use and compatible with built-up roofing.
  - 1. As needed and to match existing roofing.
- B. Fasteners: Factory-coated steel fasteners and metal or plastic plates complying with corrosion-resistance provisions in FM Global 4470, designed for fastening built-up roofing components to



substrate; tested by manufacturer for required pullout strength, and acceptable to roofing manufacturer.

- C. Miscellaneous Accessories: Provide those recommended by roofing system manufacturer.

### PART 3 - EXECUTION

#### 3.1 EXAMINATION

- A. Examine substrates, areas, and conditions, with Installer present, for compliance with requirements and other conditions affecting performance of the Work:
1. Verify that roof openings and penetrations are in place, curbs are set and braced, and roof-drain bodies are securely clamped in place.
  2. Verify that wood cants, blocking, curbs, and nailers are securely anchored to roof deck at penetrations and terminations and that nailers match thicknesses of insulation.
  3. Verify that concrete curing compounds that impair adhesion of roofing components to roof deck have been removed.
- B. Proceed with installation only after unsatisfactory conditions have been corrected.

#### 3.2 PREPARATION

- A. Clean substrate of dust, debris, moisture, and other substances detrimental to roofing installation according to roofing manufacturer's written instructions. Remove sharp projections.
- B. Prevent materials from entering and clogging roof drains and conductors and from spilling or migrating onto surfaces of other construction. Remove roof-drain plugs when no work is taking place or when rain is forecast.

#### 3.3 INSTALLATION, GENERAL

- A. Comply with built-up roofing manufacturer's written instructions.
- B. Asphalt Heating: Heat asphalt to its equiviscous temperature, measured at the mop cart or mechanical spreader immediately before application. Circulate asphalt during heating. Do not raise asphalt temperature above equiviscous temperature range more than one hour before time of application. Do not exceed asphalt manufacturer's recommended temperature limits during asphalt heating. Do not heat asphalt within 25 deg F of flash point. Discard asphalt maintained at a temperature exceeding finished blowing temperature for more than 4 hours.
1. Apply hot roofing asphalt within plus or minus 25 deg F of equiviscous temperature.
- C. Asphalt Heating: Heat and apply SEBS-modified roofing asphalt according to roofing manufacturer's written instructions.
- D. Substrate-Joint Penetrations: Prevent roofing asphalt and adhesives from penetrating substrate joints, entering building, or damaging built-up roofing components or adjacent building construction.

#### 3.4 BUILT-UP ROOFING INSTALLATION, GENERAL

- A. Patching of existing built-up roofing only. Match existing installation.

3.5 FLASHING AND STRIPPING INSTALLATION

- A. Install base flashing over cant strips and other sloping and vertical surfaces, at roof edges, and at penetrations through roof; secure to substrates according to built-up roofing manufacturer's written instructions and as follows:
  - 1. Prime substrates with asphalt primer if required by built-up roofing manufacturer.
  - 2. Backer-Sheet Application: Mechanically fasten backer sheet to walls or parapets, as applicable..
  - 3. Flashing-Sheet Application: As applicable to match existing.

3.6 PROTECTING AND CLEANING

- A. Protect built-up roofing from damage and wear during remainder of construction period. When remaining construction does not affect or endanger roofing, inspect roofing for deterioration and damage, describing its nature and extent in a written report, with copies to Architect and Owner.
- B. Correct deficiencies in or remove built-up roofing that does not comply with requirements, repair substrates, and repair or reinstall roofing to a condition free of damage and deterioration at time of Substantial Completion and according to warranty requirements.
- C. Clean overspray and spillage from adjacent construction using cleaning agents and procedures recommended by manufacturer of affected construction.

**END OF SECTION 07 51 13**

## **SECTION 07 62 00 – SHEET METAL FLASHING AND TRIM**

### **PART 1 - GENERAL**

#### **1.1 RELATED DOCUMENTS**

- A. Drawings and general provisions of the Contract, including General Conditions and Division 1 Specification Sections, apply to this Section.

#### **1.2 SUMMARY**

- A. This Section includes flashing and sheet metal and related work as shown and specified.

#### **1.3 SUBMITTALS**

- A. Product Data: Submit manufacturer's specifications, data, and installation instructions for review.
  - 1. VOC content of each adhesive, adhesive primer, sealant, sealant primer, paint and coating.
- B. Shop Drawings: Submit manufacture and installation details, including fastenings, for review.
- C. Samples: If specifically requested.
- D. Installer Qualifications: If requested, provide evidence that installers meet the requirements of Article 1.4.
- E. Closeout Submittals: Provide completed Guarantee form per Article 1.5.

#### **1.4 QUALITY ASSURANCE**

- A. Installer Qualifications: Minimum of 3 years of experience on similar work; knowledge and understanding of standards referenced herein; skill necessary to perform in compliance with this specification. Installers failing to demonstrate the required experience, knowledge, or skill shall be removed from the project.
- B. Sheet Metal Flashing and Trim Standard: Comply with SMACNA's "Architectural Sheet Metal Manual" unless more stringent requirements are specified or shown on Drawings. If a specific detail is not shown, use a detail from the SMACNA Manual appropriate to that condition.
- C. All adhesives, adhesive primers, sealants, sealant primers, paints and coatings shall comply with the VOC limits set forth in the California Green Building Standards Code, Title 24 Part 11. Refer to Section 01 35 63 – CALGREEN REQUIREMENTS.

#### **1.5 GUARANTEE**

- A. Provide in required form for a period of 1 year from date of acceptance by Owner
- B. .

#### **1.6 DELIVERY, STORAGE, AND HANDLING**

- A. Stack preformed material to prevent twisting, bending or abrasion; slope to ensure drainage.

### **PART 2 - PRODUCTS**

#### **2.1 GALVANIZED SHEET METAL**

- A. Per ASTM A653, Grade A, G90 zinc coating; 24 gage minimum, core steel.

## **2.2 Self-Adhered Flashing (SAF)**

- A. General (at wall locations): Grace Vycor Plus, as manufactured by Grace Construction Products.
- B. Roof locations: Grace Roof Detail Membrane, confirm product with geographic location.
- C. Alternate Manufacturers: Comparable products manufactured by the Pecora Corporation; proposed equals are subject to substitution process per Section 01 25 00 – SUBSTITUTION PROCEDURES.

## **2.3 FASTENERS**

- A. General: Same metal as sheet metal flashing or other noncorrosive metal as recommended by sheet metal manufacturer. Match finish of exposed heads with material being fastened.
- B. Nails:
  - 1. General: FS FF-N-105
  - 2. Steel: Hot-dipped galvanized, annular thread, size as required.
  - 3. Concrete: Flat head, size as required.
- C. Rivets: 1/8 inch diameter; solid type.
- D. Washers: Lead or neoprene, where required.

## **2.4 SOLDER**

- A. General: ASTM B32; 50/50 type; lead free.
- B. Flux: FS A-A-51145D.

## **2.5 GALVANIZING REPAIR TREATMENT**

- A. Zinc Alloy Rod: Zinc-based solder Per ASTM A780.
- B. Comply with VOC limits set forth above.

## **2.6 PROTECTIVE COATINGS**

- A. Asphaltic Primer: ASTM D41
- B. Bituminous Paint: FS TT-C-494, Type II; bituminous.
- C. Backing Paint: Galvanized steel primer as specified in Section 09 90 00- PAINTING AND COATING.
- D. Comply with VOC limits set forth above.

## **2.7 PLASTIC CEMENT**

- A. Per FS SS-C-153, Type I; asphaltic.
- B. Comply with VOC limits set forth above.

## **2.8 SEALANTS**

- A. Per FS TT-S-230, non-hardening, non-sagging.
- B. Comply with VOC limits set forth above.

## 2.9 FABRICATION

- A. General: Form sections from galvanized sheet metal, per referenced standards, true to shape, accurate in size, square, and free from distortion or defects. Form pieces in single length sheets, not to exceed 10'-0" in length. Hem exposed edges on underside 1/2 inch; miter and factory solder inside and outside corners. If a specific detail is not shown, use a detail from the SMACNA "Architectural Sheet Metal Manual" appropriate to that condition.
- B. Seams: Drive cleat or lock.
- C. Cleats: Minimum 2 inches wide, interlockable with sheet.
- D. Vertical Faces: Bottom edge formed outward 1/4 inch and hemmed to form drip.
- E. Flashing Toe: Extend toe 2 inches over roofing; return and brake edges.
- F. Soldering: Solder shop formed metal joints. Spot weld for permanent alignment. Solder joints water-tight. After soldering, remove flux; wipe and wash solder joints clean.
- G. Assemblies:
  - 1. Exterior Hollow Metal Frame Flashing: 24 gage, as shown.

## PART 3 - EXECUTION

### 3.1 EXAMINATION

- A. Examine conditions of work in place before beginning work; report defects.
- B. Proceed with installation only after unsatisfactory conditions have been corrected.

### 3.2 PREPARATION

- A. Take field measurements; report variance between plan and field dimensions.

### 3.3 INSTALLATION

- A. Install in conformance with referenced standards, manufacturer's written directions, as shown, and as specified.
- B. Underlayment:
  - 1. General: Apply 1 layer of felt underlayment over surfaces as shown; lap all edges 6 inches minimum, in direction of slope.
  - 2. Self-Adhered Flashing: Install as shown.
- C. Application:
  - 1. Spot welding provides connection; soldering provides waterproofing.
  - 2. General: Make corners square, surfaces true and straight in planes, and lines accurate to profiles. Fit sheet metal tight in place; secure using concealed fasteners. Apply plastic cement compound between metal flashings and felt flashings. Spot weld and solder metal joints watertight.
  - 3. Expansion and Contraction: Allow for expansion and contraction over an ambient temperature range up to 150 degrees F; distortions resulting from fastening or expansion and contraction stresses not acceptable
  - 4. Dissimilar Metals: Isolate with heavy coat of bituminous paint. Coat all sheet metal in contact with roofing felts.

D. Assemblies:

1. Flashing:

- a. General: Miter joints at corners; spot weld and solder joints watertight. Lap flashings to drain; spot weld and solder joints watertight. Install flashing in longest lengths practical. Lap end joints not less than 6 inches and seal with 2 strips of sealing tape. Extend counterflashing down not less than 6 inches.
- b. Exterior Hollow Metal Frame Flashing: Provide at frame heads, as shown.

E. Sealants: As shown; per manufacturer's directions.

F. Galvanizing Repair Treatment: Repair damaged zinc coating with specified repair compound, as required.

**3.4 CLEANING**

A. Keep premises free from accumulation of waste and debris. At completion of installation remove surplus materials and debris.

B. Remove and recycle excess material as required by the Construction Waste Management Plan, Section 01 74 19 - CONSTRUCTION WASTE MANAGEMENT.

END SECTION 07 62 00

## **SECTION 07 72 00 – ROOF ACCESSORIES**

### **PART 1 - GENERAL**

#### **1.1 RELATED DOCUMENTS**

- A. Drawings and general provisions of the Contract, including General Conditions and Division 1 Specification Sections, apply to this Section.

#### **1.2 SUMMARY**

- A. This Section includes roof accessories and related work as shown and specified.

#### **1.3 SUBMITTALS**

- A. Product Data: For each type of roof accessory indicated. Include construction details, material descriptions, dimensions of individual components and profiles, and finishes.
- B. Closeout Submittals
  - 1. O & M Manuals: Maintenance and cleaning instructions
  - 2. Guarantee: Provide completed forms per Article 1.4.

#### **1.4 GUARANTEE**

- A. Provide in required form for a period of 1 year from date of acceptance by Owner.

#### **1.5 DELIVERY, STORAGE, AND HANDLING**

- A. Pack, handle, and ship roof accessories properly labeled in heavy-duty packaging to prevent damage.

### **PART 2 - PRODUCTS**

#### **2.1 ROOF HATCHES (RH)**

- A. Acceptable Products:
  - 1. Model B-RHG, as manufactured by Babcock-Davis, a Cierra Products Company.
  - 2. Model S-20, as manufactured by Bilco Company.
  - 3. Model M, as manufactured by Milcor Inc., a Gibraltar Company.
- B. Alternate Manufacturers: Proposed equals are subject to substitution procedure per Section 01 25 00 – SUBSTITUTION PROCEDURES .
- C. Construction: Manufacturer's standard insulated double-wall lids and insulated double-wall curb frame with integral deck mounting flange and lid frame counterflashing.
- D. Factory Finish: Galvanized steel; red oxide primer.
- E. Hardware: Manufacturer's standard zinc plated steel.
- F. Ladder Safety Post: Manufacturer's standard ladder safety post. Post to lock in place on full extension. Provide release mechanism to return post to closed position.
- G. Safety Railing System: Manufacturer's standard complete system including rails, clamps, fasteners, safety barrier at railing opening, and all accessories required for a complete installation.

- H. Size: 30 x 36 inches.

## PART 3 - EXECUTION

### 3.1

- A. Examine conditions of work in place before beginning work; report defects.
- B. Proceed with installation only after unsatisfactory conditions have been corrected.

### 3.2 INSTALLATION

- A. General: Install roof accessories according to manufacturer's written instructions.
- B. Install roof accessories to fit substrates and to result in watertight performance.
- C. Metal Protection: Where dissimilar metals will contact each other or corrosive substrates, protect against galvanic action by painting contact surfaces with bituminous coating or by other permanent separation as recommended by manufacturer.
- D. Install roof accessories level, plumb, true to line and elevation, and without warping, jogs in alignment, excessive oil canning, buckling, or tool marks.

### 3.3 ADJUSTMENT

- A. Prior to acceptance, adjust moveable parts to assure smooth operation.

### 3.4 CLEANING

- A. Keep premises free from accumulation of waste and debris. At completion of installation remove surplus materials and debris.
- B. Remove and recycle excess material as required by the Construction Waste Management Plan, Section 01 74 19 - CONSTRUCTION WASTE MANAGEMENT.
- C. At completion clean exposed surfaces in a manner that will not damage finish.

**END SECTION 07 72 00**



## SECTION 07 92 00 – JOINT SEALANTS

### PART 1 - GENERAL

#### 1.1 SUMMARY

- A. This Section includes joint sealers and related work as shown and specified.

#### 1.2 SUBMITTALS

- A. Product Data: Submit manufacturer's specifications, data, and installation instructions for review. VOC content of each adhesive, adhesive primer, sealant, caulking and sealant primer.

#### 1.3 QUALITY ASSURANCE

- A. General: The manufacturer of the sealant used shall have been in the business of manufacturing the specified types of such sealants for not less than 10 years.
- B. Installer Qualifications: Minimum of 5 years of experience on similar work; knowledge and understanding of standards referenced herein; skill necessary to perform in compliance with this specification. Installers failing to demonstrate the required experience, knowledge, or skill shall be removed from the project.
- C. Volatile Organic Compounds (VOC): Use only products in compliance with VOC content limits required by Federal and State EPA regulations.
- D. Compatibility with Substrate: Verify that caulking and sealants used are compatible with joint materials.
- E. Joint Tolerances: Comply with manufacturer's joint width to depth ratio limitations.

#### 1.4 GUARANTEE

- A. Provide in required form for a period of 2 years from date of final acceptance by Owner.
- B. Provide material in manufacturer's standard form for a period of 5 years from date of acceptance by owner.

### PART 1 - PRODUCTS

#### 1.5 JOINT SEALANTS

- A. Acceptable Manufacturers:
  - 1. Tremco, Inc.
  - 2. Sika
  - 3. Pecora Corp.
- B. Alternate Manufacturers: Proposed equals are subject to substitution process per Section 01 25 00 – SUBSTITUTION PROCEDURES .
- C. Exterior Joints:
  - 1. Vertical surfaces are walls.

2. Vertical Surfaces: Non-sag polyurethane; Dymeric 240 FC.
- D. Interior Joints:
1. General: Acrylic latex.
    - a. Tremflex 834, as manufactured by Tremco.
    - b. AC-20, as manufactured by Pecora Corporation.
    - c. Sonolac, as manufactured by Sonneborn, BASF Building Systems.
  2. Silicone is a non-paintable surface.
  3. Ceramic Tile and Plumbing Fixture Joints: Silicone rubber; Tremsil 200.
  4. Firestop Caulking:
    - a. Acceptable Products: Metacaulk, as manufactured by the Rectorseal Corp.
    - b. Alternate Products: Comparable products manufactured by the Dow Corning Corp. Proposed equals are subject to substitution process per Section 01 25 00 – SUBSTITUTION PROCEDURES .
- E. Joint Cleaner: Provide cleaner recommended by sealant manufacturer for specific joint surface and condition.
- F. Joint Primer and Sealer: As recommended by sealant manufacturer for each condition.
- G. Bond Breaker Tape: Pressure sensitive polyethylene tape.
- H. Other Materials: Manufacturer's standard for items required or type best suited for intended use.
- I. Colors:
1. Concealed Joints: Manufacturer's standard color having best overall performance characteristics for indicated application.
  2. Select first option if color is selected during design. Select second option if color is to be selected during construction administration.
  3. Exposed Joints: Match adjacent surface.

## PART 2 - EXECUTION

### 1.6 PREPARATION

- A. Environmental Requirements: Do not apply materials when temperature is below 40 degrees F, or under extreme temperature conditions when joint width is expanded or contracted beyond normal conditions.
- B. Surfaces: Prepare joints in accordance with manufacturer's recommended instruction to ensure maximum adhesion. Prime as required, protecting adjacent exposed surfaces.
- C. Sealants: Prepare sealant as required, including proper mixing of multicomponent sealants.
- D. Protect surfaces adjacent to joints to receive sealant. Cover joints in walking surfaces with heavy duty, non-staining tape, until material has dried.

1.7 EXAMINATION

- A. General: Carefully examine before beginning work; report defects.
- B. Substrate: Inspect surfaces to insure that no bond-breaker materials contaminate the surface to which the sealant is to adhere and to ensure that unsound substrates are repaired.
- C. Storage: Per manufacturer's recommendations for proper precautions for shelf life, temperature, humidity and similar storage factors to ensure the fitness of the material when installed.

1.8 INSTALLATION

- A. Install in conformance with referenced standards, manufacturer's written directions, as shown, and as specified.
- B. Prevent three-sided adhesion. Provide sealant depth of 1/2 joint width; minimum depth of 1/4 inch; maximum of 1/2 inch, unless otherwise required by the manufacturer.
- C. Backer Rod: Install using blunt or rounded tools to insure uniform (plus or minus 1/8 inch) depth without puncturing material. Oversize backer rod minimum of 33% for closed cell type, minimum of 50% for open cell type, unless otherwise required by the manufacturer.

1.9 CLEANING

- A. Keep premises free from accumulation of waste and debris. At completion of installation remove surplus materials and debris.
- B. At completion clean exposed surfaces in a manner that will not damage finish.

**END SECTION 07 92 00**

## **SECTION 08 11 13 - HOLLOW METAL DOORS AND FRAMES**

### **PART 1 - GENERAL**

#### **1.1 SUMMARY**

- A. Section includes:
  - 1. Interior standard steel doors and frames.
  - 2. Exterior standard steel doors and frames.

#### **1.2 ACTION SUBMITTALS**

- A. Product Data: For each type of product.
- B. Shop Drawings: Include the following:
  - 1. Elevations of each door type.
  - 2. Details of doors, including vertical- and horizontal-edge details and metal thicknesses.
  - 3. Frame details for each frame type, including dimensioned profiles and metal thicknesses.
- C. Product Schedule: For hollow-metal doors and frames, prepared by or under the supervision of supplier, using same reference numbers for details and openings as those on Drawings. Coordinate with final door hardware schedule.

#### **1.3 INFORMATIONAL SUBMITTALS**

- A. Product test reports.
- B. Field quality control reports.

#### **1.4 CLOSEOUT SUBMITTALS**

- A. Record Documents: List of door numbers and applicable room name and number to which door accesses.

### **PART 2 - PRODUCTS**

#### **2.1 MANUFACTURERS**

- A. Manufacturers: Subject to compliance with requirements, available manufacturers offering products that may be incorporated into the work include, but are not limited to the following:
  - 1. Basis of Design: Curries Company, Trio E Steel Stiffened Door with Filled Top Channel – EPD Available.
  - 2. Ceco Door, ASSA ABLOY.
  - 3. Steelcraft, an Allegion brand.

#### **2.2 INTERIOR STANDARD STEEL DOORS AND FRAMES**

- A. Construct hollow-metal doors and frames to comply with standards indicated for materials, fabrication, hardware locations, hardware reinforcement, tolerances, and clearances, and as specified

2.3 EXTERIOR STANDARD STEEL DOORS AND FRAMES

- A. Construct hollow-metal doors and frames to comply with standards indicated for materials, fabrication, hardware locations, hardware reinforcement, tolerances, and clearances, and as specified.

2.4 BORROWED LITES

- A. Fabricate to match adjacent door frame construction.
- B. Construction: Full profile welded.
- C. Fabricate in one piece except where handling and shipping limitations require multiple sections. Where frames are fabricated in sections due to shipping or handling limitations, provide alignment plates or angles at each joint, fabricated of metal of same or greater thickness as metal as frames.
- D. Provide countersunk, flat- or oval-head exposed screws and bolts for exposed fasteners unless otherwise indicated.

2.5 FRAME ANCHORS

- A. Jamb Anchors:
  - 1. Type: Anchors of minimum size and type required by applicable door and frame standard, and suitable for performance level indicated.
  - 2. Quantity: Minimum of three anchors per jamb, with one additional anchor for frames with no floor anchor. Provide one additional anchor for each 24 inches of frame height above 7 feet.
  - 3. Post-installed Expansion Anchor: Minimum 3/8-inch diameter bolts with expansion shields or inserts, with manufacturer's standard pipe spacer.
- B. Floor Anchors: Provide floor anchors for each jamb and mullion that extends to floor.
- C. Floor Anchors for Concrete Slabs with Underlayment: Adjustable-type anchors with extension clips, allowing not less than 2-inch height adjustment. Terminate bottom of frames at top of underlayment.
- D. Material: ASTM A 879/A 879M, Commercial Steel (CS), coating designation; mill phosphatized.
  - 1. For anchors built into exterior walls, steel sheet complying with ASTM A 1008/A 1008M or ASTM A 1011/A 1011M; hot-dip galvanized according to ASTM A 153/A 153M, Class B.

2.6 MATERIALS

- A. Cold-Rolled Steel Sheet: ASTM A 1008/A 1008M, Commercial Steel (CS), Type B; suitable for exposed applications.
- B. Hot-Rolled Steel Sheet: ASTM A 1011/A 1011M, Commercial Steel (CS), Type B; free of scale, pitting, or surface defects; pickled and oiled.
- C. Metallic-Coated Steel Sheet: ASTM A 653/A 653M, Commercial Steel (CS), Type B.
- D. Inserts, Bolts, and Fasteners: Hot-dip galvanized according to ASTM A 153/A 153M.

- E. Power-Actuated Fasteners in Concrete: Fastener system of type suitable for application indicated, fabricated from corrosion-resistant materials, with clips or other accessory devices for attaching hollow-metal frames of type indicated.
- F. Mineral-Fiber Insulation: ASTM C 665, Type I (blankets without membrane facing); consisting of fibers manufactured from slag or rock wool; with maximum flame-spread and smoke-developed indexes of 25 and 50, respectively; passing ASTM E 136 for combustion characteristics.
- G. Glazing: Comply with requirements in Section 08 80 00 "Glazing."

## 2.7 FABRICATION

- A. Hollow-Metal Frames: Fabricate in one piece except where handling and shipping limitations require multiple sections. Where frames are fabricated in sections, provide alignment plates or angles at each joint, fabricated of metal of same or greater thickness as frames.
  - 1. Sidelite Frames: Provide closed tubular members with no visible face seams or joints, fabricated from same material as door frame. Fasten members at crossings and to jambs by welding.
  - 2. Provide countersunk, flat- or oval-head exposed screws and bolts for exposed fasteners unless otherwise indicated.
  - 3. Door Silencers: Except on weather-stripped frames, drill stops to receive door silencers as follows. Keep holes clear during construction.
    - a. Single-Door Frames: Drill stop in strike jamb to receive three door silencers.
    - b. Acoustic Rated Door Frames: Provide acoustic seals in lieu of door silencers.
- B. Hardware Preparation: Factory prepare hollow-metal doors and frames to receive templated mortised hardware, and electrical wiring; include cutouts, reinforcement, mortising, drilling, and tapping according to SDI A250.6, the Door Hardware Schedule, and templates.
  - 1. Reinforce doors and frames to receive non-templated, mortised, and surface-mounted door hardware.
  - 2. Comply with BHMA A156.115 for preparing hollow-metal doors and frames for hardware.
  - 3. Provide appropriate factory preparation for all door frames scheduled to receive electric strikes.
- C. Glazed Lites: Provide stops and moldings around glazed lites where indicated. Form corners of stops and moldings with mitered hairline joints.
  - 1. Provide stops and moldings flush with face of door, and with square stops unless otherwise indicated.
  - 2. Provide fixed frame moldings on outside of exterior and on secure side of interior doors and frames. Provide loose stops and moldings on inside of hollow-metal doors and frames.
  - 3. Coordinate rabbet width between fixed and removable stops with glazing and installation types indicated.
  - 4. Provide stops for installation with countersunk flat- or oval-head machine screws spaced uniformly not more than 9 inches o.c. and not more than 2 inches o.c. from each corner.

## 2.8 STEEL FINISHES

- A. Prime Finish: Clean, pretreat, and apply manufacturer's standard primer.

1. Shop Primer: Manufacturer's standard, fast-curing, lead- and chromate-free primer complying with SDI A250.10; recommended by primer manufacturer for substrate; compatible with substrate and field-applied coatings despite prolonged exposure.

### PART 3 - EXECUTION

#### 3.1 PREPARATION

- A. Remove welded-in shipping spreaders installed at factory. Restore exposed finish by grinding, filling, and dressing, as required to make repaired area smooth, flush, and invisible on exposed faces. Touch up factory-applied finishes where spreaders are removed.
- B. Drill and tap doors and frames to receive non-templated, mortised, and surface-mounted door hardware.

#### 3.2 INSTALLATION

- A. Hollow-Metal Frames: Comply with SDI A250.11 NAAMM-HMMA 840.
  1. Set frames accurately in position; plumbed, aligned, and braced securely until permanent anchors are set. After wall construction is complete, remove temporary braces without damage to completed Work.
  2. Floor Anchors: Secure with post-installed expansion anchors.
    - a. Floor anchors may be set with power-actuated fasteners instead of post-installed expansion anchors if so indicated and approved on Shop Drawings.
  3. Installation Tolerances: Adjust hollow-metal frames to the following tolerances:
    - a. Squareness: Plus or minus 1/16 inch, measured at door rabbet on a line 90 degrees from jamb perpendicular to frame head.
    - b. Alignment: Plus or minus 1/16 inch, measured at jambs on a horizontal line parallel to plane of wall.
    - c. Twist: Plus or minus 1/16 inch, measured at opposite face corners of jambs on parallel lines, and perpendicular to plane of wall.
    - d. Plumbness: Plus or minus 1/16 inch, measured at jambs at floor.
- B. Hollow-Metal Doors: Fit and adjust hollow-metal doors accurately in frames, within clearances specified below.
  1. Non-Fire-Rated Steel Doors: Comply with SDI A250.8 NAAMM-HMMA 841 and NAAMM-HMMA guide specification indicated.
- C. Glazing: Comply with installation requirements in Section 08 80 00 "Glazing" and with hollow-metal manufacturer's written instructions.

#### 3.3 FIELD QUALITY CONTROL

- A. Repair or remove and replace installations where inspections indicate that they do not comply with specified requirements.
- B. Reinspect repaired or replaced installations to determine if replaced or repaired door assembly installations comply with specified requirements.

3.4 CLEANING AND TOUCHUP

- A. Metallic-Coated Surface Touchup: Clean abraded areas and repair with galvanizing repair paint according to manufacturer's written instructions.
- B. Touchup Painting: Cleaning and touchup painting of abraded areas of paint are specified in painting Sections.

**END OF SECTION 08 11 13**



## SECTION 08 14 16 - FLUSH WOOD DOORS

### PART 1 - GENERAL

#### 1.1 SUMMARY

A. Section Includes:

1. Five-ply flush wood veneer-faced doors for transparent finish.
2. Factory finishing flush wood doors.
3. Factory fitting flush wood doors to frames and factory machining for hardware.

B. Related Requirements:

1. Section 08 80 00 "Glazing" for glass view panels in flush wood doors.
2. Section 09 90 00 "Paint and Coating" for transparent wood finish.

#### 1.2 ACTION SUBMITTALS

A. Product Data: For each type of product, including the following:

1. Door core materials and construction.
2. Door edge construction
3. Door face type and characteristics.
4. Factory-machining criteria.
5. Factory- finishing specifications.

B. Shop Drawings: Indicate location, size, and hand of each door; elevation of each type of door; construction details not covered in Product Data; and the following:

1. Door schedule indicating door and frame location, type, size, fire protection rating, and swing.
2. Door elevations, dimension and locations of hardware, lite and louver cutouts, and glazing thicknesses.
3. Details of frame for each frame type, including dimensions and profile.
4. Details of electrical raceway and preparation for electrified hardware, access control systems, and security systems.
5. Dimensions and locations of blocking for hardware attachment.
6. Clearances and undercuts.
7. Requirements for veneer matching.

C. Samples: 3 samples for factory-finished doors. Samples shall be 4-inch x 4-inch minimum.

#### 1.3 CLOSEOUT SUBMITTALS

A. Record Documents: For fire-rated doors, list of door numbers and applicable room name and number to which door accesses.

### PART 2 - PRODUCTS

#### 2.1 FLUSH WOOD DOORS, GENERAL

A. Quality Standard: In addition to requirements specified, comply with "Architectural Woodwork Standards." WDMA I.S. 1A.

## 2.2 FIVE-PLY FLUSH WOOD VENEER-FACED DOORS FOR TRANSPARENT FINISH.

### A. Interior Doors:

1. Manufacturers: Subject to compliance with requirements, available manufacturers offering products that may be incorporated into the work include:
  - a. Algoma Hardwoods, Inc.
  - b. Buell Door Company Inc.
  - c. Eggers Industries.
  - d. Marshfield Door Systems, Inc.
  - e. VT Industries Inc.
  - f. Graham wood Doors, an ASSA ABLOY group company.
  - g. Oshkosh Architectural Door Company.
2. Performance Grade:
  - a. WDMA I.S. 1A Heavy Duty: Storage closets (not including Custodial), and private toilets. WDMA I.S. 1A Extra Heavy Duty: unless otherwise indicated on Drawings.
3. Architectural Woodwork Standards WDMA I.S. 1A Grade: Premium.
4. Faces: Single-ply wood veneer not less than 1/50 inch thick.
  - a. Species: Select maple, provide physical samples for review.
  - b. Cut: Quarter sliced.
  - c. Match between Veneer Leaves: Bookmatch.
  - d. Assembly of Veneer Leaves on Door Faces: Center-balance match.
  - e. Pair and Set Match: Provide for doors hung in same opening or separated only by mullions.
  - f. Room Match: Provide door faces of compatible color and grain within each separate room or area of building.
5. Exposed Vertical Edges: Same species as faces - Architectural Woodwork Standards edge Type A.
  - a. Mineral-Core Doors: At hinge stiles, provide laminated-edge construction with improved screw-holding capability and split resistance. Comply with specified requirements for exposed edges.
    - 1) Screw-Holding Capability: 550 lbf in accordance with WDMA T.M. 10.
6. Core for Non-Fire-Rated Doors: Agrifiber.
  - a. Blocking: Provide wood blocking in agrifiber-core doors as needed to eliminate through-bolting hardware.
    - 1) 5-inch top-rail blocking, in doors indicated to have closers.
    - 2) 5-inch bottom-rail blocking, in exterior doors and doors indicated to have kick, mop, or armor plates.
    - 3) 5-inch midrail blocking, in doors indicated to have exit devices.
  - b. Provide doors with glued-wood-stave or WDMA I.S. 10 structural-composite-lumber cores instead of agrifiber cores for doors scheduled to receive exit devices in Section 08 71 00 "Door Hardware."

7. Construction: Five plies, hot-pressed bonded (vertical and horizontal edging is bonded to core), with entire unit abrasive planed before veneering.

## 2.3 FABRICATION

- A. Factory fit doors to suit frame-opening sizes indicated.
  1. Comply with clearance requirements of referenced quality standard for fitting unless otherwise indicated.
  2. Comply with NFPA 80 requirements for fire-rated doors.
- B. Factory machine doors for hardware that is not surface applied.
  1. Locate hardware to comply with DHI-WDHS-3.
  2. Comply with final hardware schedules, door frame Shop Drawings, BHMA-156.115-W, and hardware templates.
  3. Coordinate with hardware mortises in metal frames, to verify dimensions and alignment before factory machining.
  4. For doors scheduled to receive electrified locksets, provide factory-installed raceway and wiring to accommodate specified hardware.

## 2.4 FACTORY FINISHING

- A. Comply with referenced quality standard for factory finishing.
  1. Complete fabrication, including fitting doors for openings and machining for hardware that is not surface applied, before finishing.
  2. Finish faces, all four edges, edges of cutouts, and mortises.
  3. Fillers may be omitted on bottom edges, edges of cutouts, and mortises.
- B. Factory finish doors with Transparent Finish:
  1. Premium.
  2. Finish: Manufacturer's Standard low VOC.
  3. Staining: None.
  4. Sheen: Satin.

## PART 3 - EXECUTION

### 3.1 INSTALLATION

- A. Hardware: For installation, see Section 08 71 00 "Door Hardware."
- B. Install doors to comply with manufacturer's written instructions and referenced quality standard, and as indicated.
- C. Install frames level, plumb, true, and straight.
  1. Shim as required with concealed shims. Install level and plumb to a tolerance of 1/8 inch in 96 inches.
  2. Anchor frames to anchors or blocking built in or directly attached to substrates.
    - a. Secure with countersunk, concealed fasteners and blind nailing.
    - b. Use fine finishing nails for exposed fastening, countersunk and filled flush with woodwork.

- 1) For factory-finished items, use filler matching finish of items being installed.
3. Install fire-rated doors and frames in accordance with NFPA 80.
- D. Factory-Fitted Doors: Align in frames for uniform clearance at each edge.
  - E. Factory-Finished Doors: Restore finish before installation if fitting or machining is required at Project site.
- 3.2 FIELD QUALITY CONTROL
- A. Inspection Agency: Engage a qualified inspector to perform inspections and to furnish reports to Architect.
  - B. Inspections:
    1. Fire-Rated Door Inspections: Inspect each fire-rated door in accordance with NFPA 80, Section 5.2.
    2. Egress Door Inspections: Inspect each door equipped with panic hardware, each door equipped with fire exit hardware, each door located in an exit enclosure, each electrically controlled egress door, and each door equipped with special locking arrangements in accordance with NFPA 101, Section 7.2.1.15.
  - C. Repair or remove and replace installations where inspections indicate that they do not comply with specified requirements.
  - D. Reinspect repaired or replaced installations to determine if replaced or repaired door assembly installations comply with specified requirements.
  - E. Prepare and submit separate inspection report for each fire-rated door assembly indicating compliance with each item listed in NFPA 80 and NFPA 101.
- 3.3 ADJUSTING
- A. Operation: Rehang or replace doors that do not swing or operate freely.
  - B. Finished Doors: Replace doors that are damaged or that do not comply with requirements. Doors may be repaired or refinished if Work complies with requirements and shows no evidence of repair or refinishing.

**END OF SECTION 08 14 16**

## **SECTION 08 31 13 - ACCESS DOORS AND FRAMES**

### **PART 1 - GENERAL**

#### **1.1 SUMMARY**

- A. Section includes access doors and frames for walls and ceilings.

#### **1.2 ACTION SUBMITTALS**

- A. Product Data: For each type of product.
- B. Product Schedule: For access doors and frames.

### **PART 2 - PRODUCTS**

#### **2.1 ACCESS DOORS AND FRAMES**

- A. Flush Access Doors with Exposed Flanges as required to complete the Work:
  - 1. Description: Face of door flush with frame, with exposed flange and concealed hinge.
  - 2. Locations: Wall and ceiling.
  - 3. Uncoated Steel Sheet for Door: Nominal 0.060 inch, 16 gage, factory primed.
  - 4. Frame Material: Same material, thickness, and finish as door.
  - 5. Latch and Lock: Cam latch, key operated Prepared for mortise cylinder.

#### **2.2 MATERIALS**

- A. Steel Plates, Shapes, and Bars: ASTM A 36/A 36M.
- B. Steel Sheet: Uncoated or electrolytic zinc coated, ASTM A 879/A 879M, with cold-rolled steel sheet substrate complying with ASTM A 1008/A 1008M, Commercial Steel (CS), exposed.
- C. Frame Anchors: Same material as door face.
- D. Inserts, Bolts, and Anchor Fasteners: Hot-dip galvanized steel according to ASTM A 153/A 153M or ASTM F 2329.

#### **2.3 FABRICATION**

- A. Metal Surfaces: For metal surfaces exposed to view in the completed Work, provide materials with smooth, flat surfaces without blemishes. Do not use materials with exposed pitting, seam marks, roller marks, rolled trade names, or roughness.
- B. Doors and Frames: Grind exposed welds smooth and flush with adjacent surfaces. Furnish mounting holes, attachment devices and fasteners of type required to secure access doors to types of supports indicated.
- C. Latch and Lock Hardware:
  - 1. Quantity: Furnish number of latches and locks required to hold doors tightly closed.
  - 2. Keys: Furnish two keys per lock and key all locks alike.
  - 3. Mortise Cylinder Preparation: Where indicated, prepare door panel to accept cylinder compatible with Section 08 71 00 "Door Hardware."

## 2.4 FINISHES

- A. Painted Finishes: Comply with coating manufacturer's written instructions for cleaning, conversion coating, and applying and baking finish.
  - 1. Factory Primed: Apply manufacturer's standard, lead- and chromate-free, universal primer immediately after surface preparation and pretreatment.

## PART 3 - EXECUTION

### 3.1 INSTALLATION

- A. Comply with manufacturer's written instructions for installing access doors and frames.
- B. Adjust doors and hardware, after installation, for proper operation.

**END OF SECTION 08 31 13**

## **SECTION 08 41 13 - ALUMINUM-FRAMED ENTRANCES AND STOREFRONTS**

### **PART 1 - GENERAL**

#### **1.1 SUMMARY**

- A. Section Includes:
  - 1. Storefront framing.
  - 2. Manual-swing entrance doors.

#### **1.2 PREINSTALLATION MEETINGS**

- A. Pre-installation Conference: Conduct conference at Project site.

#### **1.3 ACTION SUBMITTALS**

- A. Product Data: For each type of product.
- B. Shop Drawings: For aluminum-framed entrances and storefronts. Include plans, elevations, sections, full-size details, and attachments to other work.
  - 1. Show connection to and continuity with adjacent thermal, weather, air, and vapor barriers.
  - 2. Include point-to-point wiring diagrams.
- C. Samples: For each type of exposed finish required.
- D. Entrance Door Hardware Schedule: Prepared by or under supervision of supplier, detailing fabrication and assembly of entrance door hardware, as well as procedures and diagrams.
- E. Delegated-Design Submittal: For aluminum-framed entrances and storefronts indicated to comply with performance requirements and design criteria, including analysis data signed and sealed by the qualified professional engineer responsible for their preparation.

#### **1.4 INFORMATIONAL SUBMITTALS**

- A. Energy Performance Certificates: NFRC-certified energy performance values from manufacturer.
- B. Product test reports.
- C. Source quality-control reports.
- D. Field quality-control reports.
- E. Sample warranties.

#### **1.5 CLOSEOUT SUBMITTALS**

- A. Maintenance data.

## 1.6 QUALITY ASSURANCE

- A. Installer Qualifications: An entity that employs installers and supervisors who are trained and approved by manufacturer.
- B. Testing Agency Qualifications: Qualified according to ASTM E 699 for testing indicated.
- C. Product Options: Information on Drawings and in Specifications establishes requirements for aesthetic effects and performance characteristics of assemblies. Aesthetic effects are indicated by dimensions, arrangements, alignment, and profiles of components and assemblies as they relate to sightlines, to one another, and to adjoining construction.
  - 1. Do not change intended aesthetic effects, as judged solely by Architect, except with Architect's approval. If changes are proposed, submit comprehensive explanatory data to Architect for review.

## 1.7 WARRANTY

- A. See Section 01 77 00 CLOSEOUT PROCEDURES for warranty information.

## PART 2 - PRODUCTS

### 2.1 PERFORMANCE REQUIREMENTS

- A. Delegated Design: Engage a qualified professional engineer, as defined in Section 01 40 00 "Quality Requirements," to design aluminum-framed entrances and storefronts.
- B. General Performance: Comply with performance requirements specified, as determined by testing of aluminum-framed entrances and storefronts representing those indicated for this Project without failure due to defective manufacture, fabrication, installation, or other defects in construction.
  - 1. Aluminum-framed entrances and storefronts shall withstand movements of supporting structure, including, but not limited to, twist, column shortening, long-term creep, and deflection from uniformly distributed and concentrated live loads.
  - 2. Failure also includes the following:
    - a. Thermal stresses transferring to building structure.
    - b. Glass breakage.
    - c. Noise or vibration created by wind and thermal and structural movements.
    - d. Loosening or weakening of fasteners, attachments, and other components.
    - e. Failure of operating units.
- C. Structural Loads:
  - 1. Wind Loads: As indicated on Drawings.
  - 2. Other Design Loads: As indicated on Drawings.
- D. Deflection of Framing Members: At design wind pressure, as follows:
  - 1. Deflection Normal to Wall Plane: Limited to edge of glass in a direction perpendicular to glass plane not exceeding 1/175 of the glass edge length for each individual glazing lite, 1/175 of clear span for spans of up to 13 feet 6 inches and to 1/240 of clear span plus 1/4 inch for spans greater than 13 feet 6 inches or an amount that restricts edge deflection of individual glazing lites to 3/4 inch, whichever is less.



2. Deflection Parallel to Glazing Plane: Limited to 1/360 of clear span or 1/8 inch, whichever is smaller] [amount not exceeding that which reduces glazing bite to less than 75 percent of design dimension and that which reduces edge clearance between framing members and glazing or other fixed components to less than 1/8 inch.
    - a. Operable Units: Provide a minimum 1/16-inch clearance between framing members and operable units.
  3. Cantilever Deflection: Where framing members overhang an anchor point, as follows:
    - a. Perpendicular to Plane of Wall: No greater than 1/240 of clear span plus 1/4 inch for spans greater than 11 feet 8-1/4 inches or 1/175 times span, for spans of less than 11 feet 8-1/4 inches.
- E. Structural: Test according to ASTM E 330/E 330M as follows:
1. When tested at positive and negative wind-load design pressures, storefront assemblies, including entrance doors, do not evidence deflection exceeding specified limits.
  2. When tested at 150 percent of positive and negative wind-load design pressures, storefront assemblies, including entrance doors and anchorage, do not evidence material failures, structural distress, or permanent deformation of main framing members exceeding 0.2 percent of span.
  3. Test Durations: As required by design wind velocity, but not less than 10 seconds.
- F. Air Infiltration: Test according to ASTM E 283 for infiltration as follows:
1. Fixed Framing and Glass Area:
    - a. Maximum air leakage of 0.06 cfm/sq. ft. at a static-air-pressure differential of 1.57 lbf/sq. ft.
  2. Entrance Doors:
    - a. Single Doors: Maximum air leakage of 0.5 cfm/sq. ft. at a static-air-pressure differential of 1.57 lbf/sq. ft..
- G. Water Penetration under Static Pressure: Test according to ASTM E 331 as follows:
1. No evidence of water penetration through fixed glazing and framing areas, including entrance doors, when tested according to a minimum static-air-pressure differential of 20 percent of positive wind-load design pressure, but not less than 6.24 lbf/sq. ft.
- H. Energy Performance: Certify and label energy performance according to NFRC as follows:
1. Thermal Transmittance (U-factor): Fixed glazing and framing areas as a system shall have U-factor of not more than 0.41 Btu/sq. ft. x h x deg Fas determined according to NFRC 100.
  2. Solar Heat Gain Coefficient (SHGC): Fixed glazing and framing areas as a system shall have SHGC of no greater than 0.26 > as determined according to NFRC 200.
  3. Condensation Resistance: Fixed glazing and framing areas as a system shall have an NFRC-certified condensation resistance rating of no less than 15 as determined according to NFRC 500.
- I. Windborne-Debris Impact Resistance: Pass missile-impact and cyclic-pressure tests according to ASTM E 1996 for Wind Zone 1.

1. Large-Missile Test: For glazed openings located within 30 feet of grade.
- J. Thermal Movements: Allow for thermal movements resulting from ambient and surface temperature changes.
1. Temperature Change: 120 deg F, ambient; 180 deg F, material surfaces.

## 2.2 STOREFRONT SYSTEMS

- A. Subject to compliance with performance requirements provide products by one of the following:
1. EFCO.
  2. Kawneer Corporation. Product: Trifab 450UT – Basis of Design.
  3. Tubelite.
  4. Alternates approved by Architect prior to bidding. See specification section 01 25 00 Substitution Procedures.
- B. Framing Members: Manufacturer's extruded- or formed-aluminum framing members of thickness required and reinforced as required to support imposed loads.
1. Exterior Framing Construction: Thermally broken.
  2. Interior Vestibule Framing Construction: Non-thermal.
  3. Glazing System: Retained mechanically with gaskets on four sides.
  4. Finish: Clear anodic finish.
  5. Fabrication Method: Field-fabricated stick system.
  6. Aluminum: Alloy and temper recommended by manufacturer for type of use and finish indicated.
  7. Steel Reinforcement: As required by manufacturer.
- C. Backer Plates: Manufacturer's standard, continuous backer plates for framing members, if not integral, where framing abuts adjacent construction.
- D. Brackets and Reinforcements: Manufacturer's standard high-strength aluminum with non-staining, nonferrous shims for aligning system components.

## 2.3 ENTRANCE DOOR SYSTEMS

- A. Subject to compliance with performance requirements provide products by one of the following:
1. EFCO.
  2. Kawneer Corporation. Product: AA 425 – Basis of Design.
  3. Tubelite.
  4. Alternates approved by Architect prior to bidding. See specification section 01 25 00 Substitution Procedures.
- B. Entrance Doors: Manufacturer's standard glazed entrance doors for manual-swing or automatic operation.
1. Door Construction: 2- to 2-1/4-inch overall thickness, with minimum 0.125-inch- thick, extruded-aluminum tubular rail and stile members. Mechanically fasten corners with reinforcing brackets that are deeply penetrated and fillet welded or that incorporate concealed tie rods.
    - a. Thermal Construction: High-performance plastic connectors separate aluminum members exposed to the exterior from members exposed to the interior.

2. Door Design: Wide stile; 5-inch nominal width.
3. Glazing Stops and Gaskets: Beveled, snap-on, extruded-aluminum stops and preformed gaskets.
  - a. Provide non-removable glazing stops on outside of door.

## 2.4 ENTRANCE DOOR HARDWARE

- A. Entrance Door Hardware: Hardware not specified in this Section is specified in Section 08 71 00 "Door Hardware." Designations: Requirements for design, grade, function, finish, quantity, size, and other distinctive qualities of each type of entrance door hardware are indicated in "Entrance Door Hardware Sets" Article. Products are identified by using entrance door hardware designations as follows:
  1. Named Manufacturers' Products: Manufacturer and product designation are listed for each door hardware type required for the purpose of establishing minimum requirements. Manufacturers' names are abbreviated in "Entrance Door Hardware Sets" Article.
  2. References to BHMA Standards: Provide products complying with these standards and requirements for description, quality, and function.
- B. Cylinders: As specified in Section 08 71 00 "Door Hardware."
- C. Butt Hinges: BHMA A156.1, Grade 1, radius corner.
  1. Non-removable Pins: Provide setscrew in hinge barrel that, when tightened into a groove in hinge pin, prevents removal of pin while entrance door is closed.
- D. Mortise Auxiliary Locks: BHMA A156.5, Grade 1.
- E. Automatic and Self-Latching Flush Bolts: BHMA A156.3, Grade 1.
- F. Panic Exit Devices: BHMA A156.3, Grade 1, listed and labeled by a testing and inspecting agency acceptable to authorities having jurisdiction, for panic protection, based on testing according to UL 305.
- G. Cylinders: BHMA A156.5, Grade 1.
  1. Provide "Primus" cylinders are exterior doors, coordinate with owner.
  2. Provide EF key way for interior door, coordinate with owner.
  3. Keying: Master key system. Permanently inscribe each key with a visual key control number and include notation "DO NOT DUPLICATE".
- H. Strikes: Provide strike with black-plastic dust box for each latch or lock bolt; fabricated for aluminum framing.
- I. Operating Trim: BHMA A156.6.
- J. Closers: BHMA A156.4, Grade 1, with accessories required for a complete installation, sized as required by door size, exposure to weather, and anticipated frequency of use; adjustable to comply with field conditions and requirements for opening force.
- K. Door Stops: BHMA A156.16, Grade 1, floor or wall mounted, as appropriate for door location indicated, with integral rubber bumper.
- L. Weather Stripping: Manufacturer's standard replaceable components.

1. Compression Type: Made of ASTM D 2000 molded neoprene or ASTM D 2287 molded PVC.
  2. Sliding Type: AAMA 701/702, made of wool, polypropylene, or nylon woven pile with nylon-fabric or aluminum-strip backing.
- M. Weather Sweeps: Manufacturer's standard exterior-door bottom sweep with concealed fasteners on mounting strip.
- N. Thresholds: BHMA A156.21 raised thresholds beveled with a slope of not more than 1:2, with maximum height of 1/2 inch.
- O. Finger Guards: Manufacturer's standard collapsible neoprene or PVC gasket anchored to frame hinge-jamb at center-pivoted doors.

## 2.5 GLAZING

- A. Glazing: Comply with Section 08 80 00 "Glazing."
- B. Glazing Gaskets: Manufacturer's standard sealed-corner pressure-glazing system of black, resilient elastomeric glazing gaskets, setting blocks, and shims or spacers.
- C. Glazing Sealants: As recommended by manufacturer.

## 2.6 MATERIALS

- A. Sheet and Plate: ASTM B 209.
- B. Extruded Bars, Rods, Profiles, and Tubes: ASTM B 221.
- C. Extruded Structural Pipe and Tubes: ASTM B 429/B 429M.
- D. Structural Profiles: ASTM B 308/B 308M.
- E. Steel Reinforcement:
1. Structural Shapes, Plates, and Bars: ASTM A 36/A 36M.
  2. Cold-Rolled Sheet and Strip: ASTM A 1008/A 1008M.
  3. Hot-Rolled Sheet and Strip: ASTM A 1011/A 1011M.
  4. Primer: Manufacturer's standard zinc-rich, corrosion-resistant primer complying with SSPC-PS Guide No. 12.00; applied immediately after surface preparation and pretreatment. Select surface preparation methods according to recommendations in SSPC-SP COM, and prepare surfaces according to applicable SSPC standard.

## 2.7 FABRICATION

- A. Form or extrude aluminum shapes before finishing.
- B. Weld in concealed locations to greatest extent possible to minimize distortion or discoloration of finish. Remove weld spatter and welding oxides from exposed surfaces by descaling or grinding.
- C. Fabricate components that, when assembled, have the following characteristics:
1. Profiles that are sharp, straight, and free of defects or deformations.
  2. Accurately fitted joints with ends coped or mitered.

3. Physical and thermal isolation of glazing from framing members.
  4. Accommodations for thermal and mechanical movements of glazing and framing to maintain required glazing edge clearances.
  5. Provisions for field replacement of glazing from interior.
  6. Fasteners, anchors, and connection devices that are concealed from view to greatest extent possible.
- D. Mechanically Glazed Framing Members: Fabricate for flush glazing without projecting stops.
  - E. Entrance Door Frames: Reinforce as required to support loads imposed by door operation and for installing entrance door hardware.
  - F. Entrance Doors: Reinforce doors as required for installing entrance door hardware.
  - G. Entrance Door Hardware Installation: Factory install entrance door hardware to the greatest extent possible. Cut, drill, and tap for factory-installed entrance door hardware before applying finishes.
  - H. After fabrication, clearly mark components to identify their locations in Project according to Shop Drawings.

## 2.8 ALUMINUM FINISHES

- A. Clear Anodic Finish: AAMA 611, AA-M12C22A41, Class I, 0.018 mm or thicker.

## PART 3 - EXECUTION

### 3.1 INSTALLATION

- A. General:
  1. Comply with manufacturer's written instructions.
  2. Do not install damaged components.
  3. Fit joints to produce hairline joints free of burrs and distortion.
  4. Rigidly secure non-movement joints.
  5. Install anchors with separators and isolators to prevent metal corrosion and electrolytic deterioration and to prevent impeding movement of moving joints.
  6. Seal perimeter and other joints watertight unless otherwise indicated.
- B. Metal Protection:
  1. Where aluminum is in contact with dissimilar metals, protect against galvanic action by painting contact surfaces with materials recommended by manufacturer for this purpose or by installing nonconductive spacers.
  2. Where aluminum is in contact with concrete or masonry, protect against corrosion by painting contact surfaces with bituminous paint.
- C. Set continuous sill members and flashing in full sealant bed, as specified in Section 07 92 00 JOINT SEALANTS to produce weathertight installation.
- D. Install components plumb and true in alignment with established lines and grades.
- E. Install operable units level and plumb, securely anchored, and without distortion. Adjust weather-stripping contact and hardware movement to produce proper operation.

- F. Install glazing as specified in Section 08 80 00 "Glazing."
- G. Entrance Doors: Install doors to produce smooth operation and tight fit at contact points.
  - 1. Exterior Doors: Install to produce weathertight enclosure and tight fit at weather stripping.
  - 2. Field-Installed Entrance Door Hardware: Install surface-mounted entrance door hardware according to entrance door hardware manufacturers' written instructions using concealed fasteners to greatest extent possible.

### 3.2 FIELD QUALITY CONTROL

- A. Field Quality-Control Testing: Perform the following test on representative areas of aluminum-framed entrances and storefronts.
  - 1. Water-Spray Test: Before installation of interior finishes has begun, areas designated by Architect shall be tested according to AAMA 501.2 and shall not evidence water penetration.
    - a. Perform a minimum of two tests in areas as directed by Architect.
  - 2. Air Infiltration: ASTM E 783 at 1.5 times the rate specified for laboratory testing in "Performance Requirements" Article but not more than 0.09 cfm/sq. ft. at a static-air-pressure differential of 1.57 lbf/sq. ft.
    - a. Perform a minimum of two tests in areas as directed by Architect.
  - 3. Water Penetration: ASTM E 1105 at a minimum uniform static-air-pressure differential of 0.67 times the static-air-pressure differential specified for laboratory testing in "Performance Requirements" Article, but not less than 6.24 lbf/sq. ft., and shall not evidence water penetration.
    - a. Bottom track shall be filled with water and hold water for a minimum of 8-hours at exterior applications.
- B. Aluminum-framed entrances and storefronts will be considered defective if they do not pass tests and inspections.
- C. Prepare test and inspection reports.

END OF SECTION 08 41 13

## SECTION 08 51 13 - ALUMINUM WINDOWS

### PART 1 - GENERAL

#### 1.1 SUMMARY

- A. Section includes operable aluminum windows for exterior locations.

#### 1.2 PRE-INSTALLATION MEETINGS

- A. Pre-installation Conference: Conduct conference at Project site.

#### 1.3 ACTION SUBMITTALS

- A. Product Data: For each type of product.
- B. Shop Drawings: Include plans, elevations, sections, hardware, accessories, insect screens, operational clearances, and details of installation, including anchor, flashing, and sealant installation.
- C. Samples: For each exposed product and for each color specified.

#### 1.4 INFORMATIONAL SUBMITTALS

- A. Product test reports.
- B. Sample warranties.

#### 1.5 WARRANTY

- A. Manufacturer's Warranty: Manufacturer agrees to repair or replace aluminum windows that fail in materials or workmanship within specified warranty period.
  - 1. Warranty Period:
    - a. Window: 10 years from date of Substantial Completion.
    - b. Glazing Units: Five years from date of Substantial Completion.
    - c. Aluminum Finish: 10 years from date of Substantial Completion.

### PART 2 - PRODUCTS

#### 2.1 WINDOW PERFORMANCE REQUIREMENTS

- A. Product Standard: Comply with AAMA/WDMA/CSA 101/I.S.2/A440 for definitions and minimum standards of performance, materials, components, accessories, and fabrication unless more stringent requirements are indicated.
  - 1. Window Certification: AAMA certified with label attached to each window.
- B. Performance Class and Grade: AAMA/WDMA/CSA 101/I.S.2/A440 as follows:
  - 1. Minimum Performance Class: **R**.
  - 2. Minimum Performance Grade: **15**.

- C. Thermal Transmittance: NFRC 100 maximum whole-window U-factor of **0.30 Btu/sq. ft. x h x deg F.**
- D. Solar Heat-Gain Coefficient (SHGC): NFRC 200 maximum whole-window SHGC of **0.27**
- E. Condensation-Resistance Factor (CRF): Provide aluminum windows tested for thermal performance according to AAMA 1503, showing a CRF of **45**.
- F. Thermal Movements: Provide aluminum windows, including anchorage, that allow for thermal movements resulting from the following maximum change (range) in ambient and surface temperatures by preventing buckling, opening of joints, overstressing of components, failure of joint sealants, failure of connections, and other detrimental effects. Base engineering calculation on surface temperatures of materials due to both solar heat gain and nighttime-sky heat loss.
  - 1. Temperature Change: 120 deg F ambient; 180 deg F material surfaces.

## 2.2 ALUMINUM WINDOWS

- A. Subject to compliance with performance requirements manufacturers and products should be from a single source provider to match Specification Section 08 41 13 Aluminum-Framed Entrances and Storefronts.
- B. Operating Types: Awning function, operability as indicated on Drawings.
- C. Frames and Sashes: Aluminum extrusions complying with AAMA/WDMA/CSA 101/I.S.2/A440.
  - 1. Thermally Improved Construction: Fabricate frames, sashes, and muntins with an integral, concealed, low-conductance thermal barrier located between exterior materials and window members exposed on interior side in a manner that eliminates direct metal-to-metal contact.
- D. Glass: Refer to Specification Section 08 80 00 Glazing.
- E. Glazing System: Manufacturer's standard factory-glazing system that produces weathertight seal.

## 2.3 ACCESSORIES

- A. Subsills: Thermally broken, extruded-aluminum subsills in configurations indicated on Drawings.

## 2.4 FABRICATION

- A. Fabricate aluminum windows in sizes indicated. Include a complete system for assembling components and anchoring windows.
- B. Glaze aluminum windows in the factory.
- C. Weather strip each operable sash to provide weathertight installation.
- D. Weep Holes: Provide weep holes and internal passages to conduct infiltrating water to exterior.
- E. Mullions: Provide mullions and cover plates, matching window units, complete with anchors for support to structure and installation of window units. Allow for erection tolerances and provide



for movement of window units due to thermal expansion and building deflections. Provide mullions and cover plates capable of withstanding design wind loads of window units.

- F. Complete fabrication, assembly, finishing, hardware application, and other work in the factory to greatest extent possible. Disassemble components only as necessary for shipment and installation.

## 2.5 ALUMINUM FINISHES

- A. Finish designations prefixed by AA comply with the system established by the Aluminum Association for designating aluminum finishes.
- B. Class I, Clear Anodic Finish: AA-M12C22A41 (Mechanical Finish: nonspecular as fabricated; Chemical Finish: etched, medium matte; Anodic Coating: Architectural Class I, clear coating 0.018 mm or thicker) complying with AAMA 611.
- C. Class I, Color Anodic Finish: AA-M12C22A42/A44 (Mechanical Finish: nonspecular as fabricated; Chemical Finish: etched, medium matte; Anodic Coating: Architectural Class I, integrally colored or electrolytically deposited color coating 0.018 mm or thicker) complying with AAMA 611.
  - 1. Color: Match existing.

## PART 3 - EXECUTION

### 3.1 INSTALLATION

- A. Comply with manufacturer's written instructions for installing windows, hardware, accessories, and other components. For installation procedures and requirements not addressed in manufacturer's written instructions, comply with installation requirements in ASTM E 2112.
- B. Install windows level, plumb, square, true to line, without distortion or impeding thermal movement, anchored securely in place to structural support, and in proper relation to wall flashing and other adjacent construction to produce weathertight construction.
- C. Install windows and components to drain condensation, water penetrating joints, and moisture migrating within windows to the exterior.
- D. Separate aluminum and other corrodible surfaces from sources of corrosion or electrolytic action at points of contact with other materials.
- E. Clean exposed surfaces immediately after installing windows. Avoid damaging protective coatings and finishes. Remove excess sealants, glazing materials, dirt, and other substances.
- F. Remove and replace glass that has been broken, chipped, cracked, abraded, or damaged during construction period.

**END OF SECTION 08 51 13**

## PART 1 - GENERAL

### 1.1 RELATED DOCUMENTS

- A. Drawings and general provisions of the Contract, including General Conditions and Division 1 Specification Sections, apply to this Section.

### 1.2 SUMMARY

- A. This Section includes door hardware and related work as shown and specified.

### 1.3 SUBMITTALS

- A. Submission: Submit schedules within 15 days of award of contract.
- B. Hardware Schedule:
  - 1. General: Submit detailed finish hardware schedule in vertical format. Reference headings to hardware groups specified and indicate door type, or mark; describe location, hand, size, door and frame material, and fire rating, if applicable. Organize doors with identical hardware groups under one heading, either per building, or per Project. If per Project, list doors per building in numerical order.
  - 2. Non-Acceptance: Coded or keyed hardware scheduling, creating a separate heading for every door and requiring reference to master lists of products is not acceptable, and will be rejected without review.
- C. Manufacturers List:
  - 1. General: List manufacturer's names and product numbers for items used in hardware schedule to facilitate checking for compliance.
  - 2. Product Source: Furnish each type of lock and latchset from a single manufacturer, unless more than 1 manufacturer's products are specified.
- D. Product Data: Submit manufacturer's specifications, data, and installation instructions for review.
- E. Samples:
  - 1. General: If specifically requested for specified products; required for alternate products.
  - 2. Disposition: Accepted samples may be used in work; rejected samples will be returned.
- F. Qualifications: If requested, provide evidence that installers meet the requirements of Article 1.4.
- G. Closeout Submittals:
  - 1. O & M Manuals: Maintenance, operation, adjustment and cleaning instructions.
  - 2. Guarantee: Provide completed form per Article 1.5.

### 1.4 QUALITY ASSURANCE

- A. Qualifications:
  - 1. Installer Qualifications: Minimum of 3 years of experience on similar work; knowledge and understanding of standards referenced herein; skill necessary to perform in compliance with this specification. Installers failing to demonstrate the required experience, knowledge, or skill shall be removed from the project.
  - 2. Manufacturers: Specializing in production of institutional and commercial door hardware for a minimum of 5 years.

3. Supplier:

- a. General: A firm specializing in the supply and servicing of institutional and commercial door hardware for at least 5 years.

B. Coordination:

1. General: Apply hardware to aluminum, FRP or metal doors and frames, and factory prepared wood doors and frames, to template; provide 2 copies of accepted Finish Hardware Schedule for use by door and frame suppliers.
2. Distribution: Furnish 2 copies of each template to manufacturers who are not listed as current template book holders; furnish 2 copies of each template for items whose manufacturers do not provide registered template book.

- A. Fire Rated Doors: Equip fire rated doors with UL listed hardware meeting requirements of CBC Chapter 7.

C. GUARANTEE

1. Provide in required form for a period of 1 year from date of acceptance by Owner.

- D. Provide warranty on manufacturer's form that products are to be free from defects in materials and workmanship beginning at date of acceptance by Owner for the following:

1. Door Closers: 10 years.
2. Exit Devices: 5 years.
3. Locks: 5 years.

1.5 DELIVERY, STORAGE, AND HANDLING

- A. Packaging: Identify door number, hardware type, location and hand of door on each package.
- B. Keys: Label and deliver keys by registered mail or personal messenger directly to Architect.

PART 2 - PRODUCTS

2.1 DOOR HARDWARE

- A. General: Catalog numbers used to identify items in the Hardware Groups are those of the following specified manufacturers. Acceptable alternate manufacturers are as listed; items produced by acceptable alternate manufacturers, comparable to those specified in material, weight, size, function, design and finish will be considered accepted equals to those items specified and will not require submittal of physical sample or request for substitution. Architect's decision regarding any item submitted for approval as equal to that specified shall be final.

B. Hinges:

1. Acceptable Manufacturers:

- a. Ives.
- b. Or equal.

2. Alternate Manufacturers: Proposed equals are subject to substitution process per Section 01 25 00 – SUBSTITUTION PROCEDURES.

C. Latches, Locks and Cylinders:

1. Acceptable Manufacturers: Schlage Lock Company.

2. Alternate Manufacturers: No known equals; proposed equals are subject to substitution process per Section 01 25 00 – SUBSTITUTION PROCEDURES.

D. Closers:

1. Acceptable Manufacturers:
  - a. LCN Closers.
  - b. Sargent Manufacturing Company.
  - c. Norton Door Control.
2. Alternate Manufacturers: Proposed equals are subject to substitution process per Section 01 25 00 – SUBSTITUTION PROCEDURES.

E. Wall Stops:

1. Acceptable Manufacturers:
  - a. Ives.
  - b. Trimco.
2. Alternate Manufacturers: Proposed equals are subject to substitution process per Section 01 33 00 - PRODUCT SUBMITTALS AND SUBSTITUTIONS.

F. Lock Guards:

1. Acceptable Manufacturers:
  - a. Ives.
  - b. Trimco.
2. Alternate Manufacturers: Proposed equals are subject to substitution process per Section 01 33 00 - PRODUCT SUBMITTALS AND SUBSTITUTIONS.

G. Exit Devices and Mullions:

1. Acceptable Manufacturers:
  - a. Von Duprin Inc.
  - b. Sargent Manufacturing Company.
  - c. Precision Hardware Inc.
2. Alternate Manufacturers: Proposed equals are subject to substitution process per Section 01 33 00 - PRODUCT SUBMITTALS AND SUBSTITUTIONS.
3. General: Unlatching force not to exceed 15 pounds when applied in the direction of travel.

H. Thresholds and Weatherstripping:

1. Acceptable Manufacturers:
  - a. Pemko Manufacturing Company.
  - b. National Guard Products.
  - c. Alternate Manufacturers: Proposed equals are subject to substitution process per Section 01 33 00 - PRODUCT SUBMITTALS AND SUBSTITUTIONS.

I. Trim:

1. Acceptable Manufacturers:

- a. Ives.
    - b. Trimco.
  - 2. Alternate Manufacturers: Proposed equals are subject to substitution process per Section 01 33 00 - PRODUCT SUBMITTALS AND SUBSTITUTIONS.
- J. Overhead Stops and Holders:
- 1. Acceptable Manufacturers:
    - a. Glynn-Johnson.
    - b. Sargent Manufacturing Company.
  - 2. Alternate Manufacturers: Proposed equals are subject to substitution process per Section 01 33 00 - PRODUCT SUBMITTALS AND SUBSTITUTIONS.
- K. Key Cabinet:
- 1. Acceptable Manufacturers:
    - a. Key Control Systems, Inc.
    - b. Major Metalfab Company.
  - 2. Alternate Manufacturers: Proposed equals are subject to substitution process per Section 01 33 00 - PRODUCT SUBMITTALS AND SUBSTITUTIONS.
  - 3. Key cabinet sized to accommodate amount of keys needed for Project.
- L. Kickplates (KCK):
- 1. Acceptable Manufacturers: Ives.
  - 2. Alternate Manufacturers: No known equals; proposed equals are subject to substitution process per Section 01 33 00 - PRODUCT SUBMITTALS AND SUBSTITUTIONS.
- M. Special Items:
- 1. Acceptable Manufacturers:
    - a. Door Controls International.
    - b. Telkee Division of the Sunroc Corp.
  - 2. Alternate Manufacturers: Proposed equals are subject to substitution process per Section 01 33 00 - PRODUCT SUBMITTALS AND SUBSTITUTIONS.

## 2.2 MANUFACTURED UNITS

- A. Locks:
- 1. General: Provide wrought boxes for strikes.
  - 2. Keys: Furnish 3 uncut blanks for each lockset, in keyways to match project system.
- B. Closers: Key valve type or screw type; furnish one key for each 5 closers. Fasten with 4 sex bolts per closer. Provide 90 degree and 180 degree openings where indicated. Provide parallel arms with jamb attachment for all out-swinging doors. Supply drop plates at narrow top rail doors, as required.
- C. Screws, Bolts, and Fastening Devices: Exposed head oval Phillips type in countersunk holes, unless otherwise specified or required. Use screws, bolts, washers, grommets, nuts, and other fastening devices of appropriate length, type, head, metal and finish necessary for proper match and application of hardware.

- D. Thresholds: Provide thresholds, door bottoms and seals as specified, or detailed. Provide thresholds with non-standard custom-drilled screw holes or with holes drilled in the field where details indicate these requirements.
- E. Butt Hinges:
  - 1. General: Furnish locking reverse bevel doors with NRP feature butts. Provide doors with closers with ball, or oilite bearing butts.
  - 2. Exterior: Provide nonferrous metal butts for reverse bevel exterior doors, of equivalent model listed.
  - 3. Size: Unless otherwise indicated, determine size of the butts as follows:
    - a. Doors 1-3/8 inch thick and up to 2'-4" wide: 3-1/2 inch butts.
    - b. Doors 1-3/8 inch thick over 2'-4" to 3'-0" wide: 4 inch butts.
    - c. Doors 1-3/4 inch thick up to 3'-0" wide: 4-1/2 inch butts.
    - d. Doors 1-3/4 inch thick over 3'-0" wide: 5 inch butts.
  - 4. Note: Provide butts of proper width to clear trim in projection to allow 180 degree swing; determine width as follows:
    - a. Doors up to 2-1/4 inches thick: Twice the door thickness, plus trim projection, less 1/2 inch, equals the proper hinge width.
    - b. Doors 2-1/4 inches to 3 inches thick: Twice the door thickness, plus trim projection, less 3/4 inch equals the proper hinge width.
    - c. Furnish three butts for each door leaf up to 7'-0" high. Furnish an additional butt for each 2'-0" of door height over 7'-0".
  - 5. Continuous Hinges: Pinless, geared hinge leaves; joined by a continuous extruded aluminum channel cap. Fabricated to full height of door and frame and to template screw locations; with components finished after milling and drilling are complete.
- F. Astragals: Provide vandal resistant fasteners at surface mounted astragals.

## 2.3 KEYING

- A. General: Key as directed by Owner. Meet with Owner, if required, to assist in creating detailed keying schedule.
- B. Grand Master Key (GMK) System:
  - 1. General: Key to Owner's existing Grand Master Key System; 6 cut GMK and 6 cut Master Keys per set; allow for 4 Master Key sets.
  - 2. Keying: Keying to be performed by the lock manufacturer to existing on-file key charts.
- C. Key Control System: Visual; stamp keys with key set symbols.
- D. Construction Master Key System: Provide 20 construction master keys, and 4 extractor keys.
- E. Change Keys: 3 standard bow change keys per cylinder.
- F. Existing System:

## 2.4 FINISHES

- A. General: Provide finishes as follows, unless otherwise indicated:
  - 1. Hinges: Exterior 630 (32D); Interior 652 (26D)
  - 2. Locks: 626 (26D)
  - 3. Closers: Aluminum Lacquer

4. Floor Closers: 626 (26D)
5. Stops: 626 (26D)
6. Exit Devices: 626 (26D)
7. Thresholds and Weather stripping: 628 (28)
8. Trim: 626 (26D)
9. Protection Plates: 630 (32D)
10. Special Items: As Noted

### PART 3 - EXECUTION

#### 3.1 EXAMINATION

- A. Examine conditions of work in place before beginning work; report defects.
- B. Proceed with installation only after unsatisfactory conditions have been corrected.

#### 3.2 PREPARATION

- A. Take field measurements; report variance between plan and field dimensions.

#### 3.3 INSTALLATION

- A. Install in conformance with referenced standards, manufacturer's written directions, as shown, and as specified.
- B. Hardware Placement:
  1. General: Except for hinges, do not install hardware until completion of painting and finishing work. Unless otherwise shown, place hardware at following height above finish floor:
  2. Strike (Centerline) for Locks and Latches: Between 40 inches and 42 inches.
  3. Hinges: NAAMM Standards.
  4. Door Pull (Centerline): 42 inches.
  5. Push Plate (Centerline): 44 inches.
  6. Deadlocks (Centerline of Cylinder): 44 inches.
- C. Floor Clearances:
  1. Labeled Doors, No Threshold: 3/8 inch maximum
  2. Unlabeled Doors, No Threshold: 3/4 inch maximum for metal doors; 5/8 inch maximum for wood doors.
  3. At Threshold: 1/8 inch typical.
  4. Carpet: 1/8 inch over top of nap, unless otherwise shown.
- D. Install hardware in precise manner; door clearance and hardware placement as specified. Predrill pilot holes in wood for screws. Drill and tap for surface mounted hardware on metal.
- E. Hinges: Set hinge leaves snug and flat in mortises; turn screws to flat seat (do not drive). Drive hinge pins down and tighten set screws.
- F. Closers: Mount door closers for maximum swing of door before setting stops.
- G. Silencers: Set in place before adjusting strikes.
- H. Locksets: Install locks with keyways in proper position; levers, roses and escutcheons firmly attached.
- I. Thresholds: Set in waterproof sealant; secure with lead shields and countersunk screws of same finish as threshold.

J. Floor Stops: Stop must be within 4 inches of wall.

### 3.4 ADJUSTING

A. Prior to acceptance, adjust moveable parts to assure smooth operation.

B. Door Closers: Adjust for closing speed, latching speed, back checking, and hold-open devices for full control of door.

1. Adjust operation of doors to require a maximum of 5 pounds for exterior and interior doors and 15 pounds for fire doors.
2. Adjust the sweep period of the closer so that from an open position of 70 degrees, the door will take at least second 3 seconds to move to a point 3 inches from the latch, measured to the landing edge of the door.

### 3.5 CLEANING

A. Keep premises free from accumulation of waste and debris. At completion of installation remove surplus materials and debris.

B. At completion clean exposed surfaces in a manner that will not damage finish.



SCHEDULES

C. HARDWARE GROUPS:

**HW SET NO: 01**

DOOR NUMBER: 100A (PAIR EXISTING STOREFRONT)

EACH LEAF TO HAVE:

1 EA	AS REQ'D BY DOOR MFG	CYLINDER HOUSING	626	TBD
	REMAINING HARDWARE	EXISTING		
1 EA	PANIC HARDWARE	EL 98-27 NL-990NL	626	VON
1 EA	RIM CYLINDER	20-057 ICX		SCH
1 EA	PRIMUS CYLINDER	20-740		SCH
1 EA	CREDENTIAL READER	BY DIV 28		B/O
1 EA	DOOR CONTACT	679-05HM	BLK	SCE
	POWER SUPPLY	BY DIV 28		B/O

Provide new Primus cylinder at existing deadbolt. Existing door pulls and closers to remain – adjust closers to meet specifications for accessibility.

New card reader, door contacts, power transfer loops, and low voltage to devices by Sonitrol. Fail-secure. Time-controlled to auto-unlock/ remain open at 8:00am and auto-lock at 5:00pm. Always free egress. Card in. User presents credential to card reader to enter after hours. RX in push bar to shunt DPS upon egress. Sonitrol to install low voltage power from power supply to doors, connect to electric door hardware and complete operational testing.

**HW SET NO: 02 (ALT #3)**

DOOR NUMBER: 122

EACH TO HAVE:

1 EA	CONT. HINGE	224HD	628	IVE
1 EA	PANIC HARDWARE	EL 98-27	626	VON
1 EA	RIM CYLINDER	20-057 ICX		SCH
1 EA	PRIMUS CYLINDER	20-740		SCH
1 EA	STRIKE		630	VON
1 EA	SURFACE CLOSER	1460	689	LCN
1 EA	KICK PLATE	8400	630	IVE
1 EA	SEAL	429A	AL	ZER
1 EA	DOOR SWEEP	8198AA	AL	ZER
1 EA	THRESHOLD	655A-MSLA-10	A	ZER
1 EA	CREDENTIAL READER	BY DIV 28		B/O
1 EA	DOOR CONTACT	679-05HM	BLK	SCE
	POWER SUPPLY	BY DIV 28		B/O

Card reader, door contact, power transfer loop, and low voltage to devices by Sonitrol. Fail-secure. Time-controlled to auto-unlock/ remain open at 8:00am and auto-lock at 5:00pm. Always free egress. Card in. User presents credential to card reader to enter after hours. RX in push bar to shunt DPS upon egress. Sonitrol to install low voltage power from power supply to door, connect to electric door hardware and complete operational testing. W

**HW SET NO: 03**

DOOR NUMBER: 113

EACH TO HAVE:

3 EA	HINGES	5BB1 4.5 X 4.5 NRP	630	IVE
1 EA	PANIC HARDWARE	CXEL98 996L	626	VON
1 EA	RIM CYLINDER	20-057 ICX		SCH
1 EA	EF CYLINDER	20-057		SCH
1 EA	MORTISE CYCLINER	26-091		SCH
1 EA	SURFACE CLOSER	1460	689	LCN
1 EA	KICK PLATE	----	630	IVE
1 EA	CREDENTIAL READER	BY DIV 28		B/O
1 EA	DOOR CONTACT	679-05HM	BLK	SCE
	POWER SUPPLY	BY DIV 28		B/O

Card reader, door contact, power transfer loop, and low voltage to devices by Sonitrol. Fail-safe. Delayed egress. Card in. User presents credential to card reader to enter, shunt local alarm. Sonitrol to install low voltage power from power supply to door, connect to electric door hardware and complete operational testing.

**HW SET NO: 04**

DOOR NUMBERS: 107 & 121

EACH TO HAVE:

3 EA	HINGES	5BB1 4.5 X 4.5 NRP	630	IVE
1 EA	STOREROOM LOCKSET	ND80JD	626	SCH
1 EA	EF CYLINDER	20-057		SCH
1 EA	SURFACE CLOSER	1460	689	LCN
1 EA	WALL STOP	WS406/407CCV	630	IVE

Electric strike

Card reader, and low voltage to devices by Sonitrol. Fail-secure. Always free egress. Card in. User presents credential to card reader to enter. Sonitrol to install low voltage power from power supply to door frame, connect to electric strike and complete operational testing.

**HW SET NO: 05**

DOOR NUMBER: 111

EACH TO HAVE:

3 EA	HINGES	5BB1 4.5 X 4.5 NRP	630	IVE
1 EA	STOREROOM LOCKSET	ND80JD	626	SCH
1 EA	EF CYLINDER	20-057		SCH
1 EA	SURFACE CLOSER	1460	689	LCN
1 EA	THUMB TURN	B571	626	SCH

Electric strike

Card reader, and low voltage to devices by Sonitrol. Fail-secure. Always free egress. Card in. User presents credential to card reader to enter. Sonitrol to install low voltage power from power supply to door frame, connect to electric strike and complete operational testing.

**HW SET NO: 06**

DOOR NUMBERS: 102 & 106

EACH TO HAVE:

3 EA	HINGES	5BB1 4.5 X 4.5 NRP	630	IVE
1 EA	STOREROOM LOCKSET	ND80JD	626	SCH
1 EA	EF CYLINDER	20-057		SCH
1 EA	SURFACE CLOSER	1460	689	LCN

Electric strike

Card reader, and low voltage to devices by Sonitrol. Fail-secure. Always free egress. Card in. User presents credential to card reader to enter. Sonitrol to install low voltage power from power supply to door frame, connect to electric strike and complete operational testing.

**HW SET NO: 07**

DOOR NUMBER: 105

EACH TO HAVE:

3 EA	HINGES	5BB1 4.5 X 4.5 NRP	630	IVE
1 EA	STOREROOM LOCKSET	ND80JD	626	SCH
1 EA	EF CYLINDER	20-057		SCH
1 EA	SURFACE CLOSER	1460	689	LCN

Electric strike

Card reader, and low voltage to devices by Sonitrol. Fail-safe. Always free egress. Card in. User presents credential to card reader to enter. Sonitrol to install low voltage power from power supply to door frame, connect to electric strike and complete operational testing.

**HW SET NO: 08**

DOOR NUMBERS: 108, 109, 123B

EACH TO HAVE:

3 EA	HINGES	5BB1 4.5 X 4.5 NRP	630	IVE
1 EA	CLASSROOM LOCK	ND70JD	626	SCH
1 EA	CORE	20-057	626	SCH
1 EA	WALL STOP	WS406/407CCV	630	IVE
1 EA	SEAL	429A	AL	ZER

**HW SET NO: 09**

DOOR NUMBERS: 119 & 120

EACH TO HAVE:

3 EA	HINGES	5BB1 4.5 X 4.5 NRP	630	IVE
1 EA	OFFICE LOCK	ND50PD	626	SCH
1 EA	CORE	20-057	626	SCH
1 EA	WALL STOP	WS406/407CCV	630	IVE
1 EA	SEAL	429A	AL	ZER

**HW SET NO: 10**

DOOR NUMBERS: 112 & 114

EACH TO HAVE:

3 EA	HINGE	5BB1 4.5 X 4.5 NRP	630	IVE
1 EA	PUSH PLATE	8200 6" X 16"	630	IVE
1 EA	PULL PLATE	8305 8" 6" X 16"	630	IVE
1 EA	SURFACE CLOSER	1460	689	LCN
1 EA	KICK PLATE	----	630	IVE
1 EA	WALL STOP	WS406/407CCV	630	IVE
1 SET	SEAL	488S-BK		ZER

**HW SET NO: 11**

DOOR NUMBER: 110

EACH TO HAVE:

3 EA	HINGES	5BB1 4.5 X 4.5 NRP	630	IVE
1 EA	STOREROOM LOCKSET	ND80PD	626	SCH
1 EA	EF CYLINDER	20-057		SCH
1 EA	SURFACE CLOSER	1460	689	LCN
1 EA	WALL STOP	WS406/407CCV	630	IVE

Strike on inactive leaf, silencers

**HW SET NO: 12**

DOOR NUMBER: 124 (PAIR)

EACH TO HAVE:

3 EA	HINGE	5BB1 4.5 X 4.5 NRP	630	IVE
1 EA	STOREROOM LOCKSET	ND80JD	626	SCH
1 EA	EF CYLINDER	20-057		SCH
1 EA	DUMMY LATCHSET	ND170	630	SCH
1 SET	EDGE BOLTS	---		---

Strike, dummy latchset, edge bolts top and bottom on inactive leaf.

**HW SET NO: 13**

DOOR NUMBER: 115, 116

EACH TO HAVE:

3 EA	HINGES	5BB1 4.5 X 4.5 NRP	630	IVE
1 EA	PRIVACY LOCK	ND40S	626	SCH
1 EA	CORE	20-057	626	SCH
1 EA	WALL STOP	WS406/407CCV	630	IVE
1 EA	SEAL	429A	AL	ZER

**HW SET NO: 14**

DOOR NUMBER: 117

EACH TO HAVE:

3 EA	HINGES	5BB1 4.5 X 4.5 NRP	630	IVE
1 EA	PASSAGE LATCHSET	ND40S	626	SCH
1 EA	WALL STOP	WS406/407CCV	630	IVE

**HW SET NO: 15**

DOOR NUMBER: 100

EACH TO HAVE:

3 EA	HINGES	5BB1 4.5 X 4.5 NRP	630	IVE
1 EA	SURFACE CLOSER	1460	689	LCN
1 EA	PANIC HARDWARE	AX 98-996L 4'	626	VON
1 EA	RIM CYLINDER	20-057 ICX		SCH
1 EA	PRIMUS CYLINDER	20-740		SCH
1 EA	WALL STOP	WS406/407CCV	630	IVE

END SECTION 08 71 00

## **SECTION 08 8000 - GLAZING**

### **PART 1 - GENERAL**

#### **1.1 SUMMARY**

- A. Section includes:
  - 1. Glass for windows, doors, interior borrowed lites, storefront framing, glazed curtain walls, overhead sloped glazing, and operable windows.
  - 2. Glazing sealants and accessories.

#### **1.2 COORDINATION**

- A. Coordinate glazing channel dimensions to provide necessary bite on glass, minimum edge and face clearances, and adequate sealant thicknesses, with reasonable tolerances.

#### **1.3 ACTION SUBMITTALS**

- A. Product Data: For each type of product.
- B. Glass Samples: For each type of glass product other than clear monolithic vision glass; 12 inches square.
- C. Glazing Schedule: List glass types and thicknesses for each size opening and location. Use same designations indicated on Drawings.
- D. Delegated-Design Submittal: For glass indicated to comply with performance requirements and design criteria, including analysis data signed and sealed by the qualified professional engineer responsible for their preparation.

#### **1.4 INFORMATIONAL SUBMITTALS**

- A. Preconstruction adhesion and compatibility test report.

#### **1.5 QUALITY ASSURANCE**

- A. Sealant Testing Agency Qualifications: An independent testing agency qualified according to ASTM C 1021 to conduct the testing indicated.

#### **1.6 PRECONSTRUCTION TESTING**

- A. Preconstruction Adhesion and Compatibility Testing: Test each glass product, tape sealant, gasket, glazing accessory, and glass-framing member for adhesion to and compatibility with elastomeric glazing sealants.
  - 1. Testing is not required if data are submitted based on previous testing of current sealant products and glazing materials matching those submitted.

#### **1.7 WARRANTY**

- A. See Section 01 77 00 CLOSEOUT PROCEDURES for Warranty requirements.

## PART 2 - PRODUCTS

### 2.1 MANUFACTURERS

- A. Product Options: Information in the Drawings, Specifications and Glass Schedule at the end of the Section establish requirements for system's aesthetic effects and performance characteristics.
  - 1. Do not modify intended aesthetic effects, as judged solely by Architect, except with Architect's approval.

### 2.2 PERFORMANCE REQUIREMENTS

- A. Delegated Design: Engage a qualified professional engineer, as defined in Section 01 4000 "Quality Requirements," to design glazing.
- B. Structural Performance: Glazing shall withstand the following design loads within limits and under conditions indicated determined according to the International Building Code and ASTM E 1300.
  - 1. Design Wind Pressures: As indicated on Drawings.
  - 2. Differential Shading: Design glass to resist thermal stresses induced by differential shading within individual glass lites.
- C. Windborne-Debris-Impact Resistance: Exterior glazing shall comply with enhanced-protection testing requirements in ASTM E 1996 for Wind Zone indicated in Drawings when tested according to ASTM E 1886. Test specimens shall be no smaller in width and length than glazing indicated for use on Project and shall be installed in same manner as glazing indicated for use on Project.
  - 1. Large-Missile Test: For glazing located within 30 feet of grade.
- D. Safety Glazing: Where safety glazing is indicated, provide glazing that complies with 16 CFR 1201, Category II.
- E. Thermal and Optical Performance Properties: Provide glass with performance properties specified, as indicated in manufacturer's published test data, based on procedures indicated below:
  - 1. U-Factors: Center-of-glazing values, according to NFRC 100 and based on LBL's WINDOW 5.2 computer program, expressed as Btu/sq. ft. x h x deg F.
  - 2. Solar Heat-Gain Coefficient and Visible Transmittance: Center-of-glazing values, according to NFRC 200 and based on LBL's WINDOW 5.2 computer program.
  - 3. Visible Reflectance: Center-of-glazing values, according to NFRC 300.

### 2.3 GLASS PRODUCTS, GENERAL

- A. Glazing Publications: Comply with published recommendations of glass product manufacturers and organizations below unless more stringent requirements are indicated. See these publications for glazing terms not otherwise defined in this Section or in referenced standards.
  - 1. GANA Publications: "Laminated Glazing Reference Manual" and "Glazing Manual."
  - 2. IGMA Publication for Insulating Glass: SIGMA TM-3000, "North American Glazing Guidelines for Sealed Insulating Glass Units for Commercial and Residential Use."

- B. Safety Glazing Labeling: Where safety glazing is indicated, permanently mark glazing with certification label of the SGCC or another certification agency acceptable to authorities having jurisdiction. Label shall indicate manufacturer's name, type of glass, thickness, and safety glazing standard with which glass complies.
- C. Thickness: Where glass thickness is indicated, it is a minimum. Provide glass that complies with performance requirements and is not less than the thickness indicated.
- D. Strength: Where annealed float glass is indicated, provide annealed float glass, heat-strengthened float glass, or fully tempered float glass as needed to comply with "Performance Requirements" Article. Where heat-strengthened float glass is indicated, provide heat-strengthened float glass or fully tempered float glass as needed to comply with "Performance Requirements" Article. Where fully tempered float glass is indicated, provide fully tempered float glass.

## 2.4 GLASS PRODUCTS

- A. Clear Annealed Float Glass: ASTM C 1036, Type I, Class 1 (clear), Quality-Q3.
- B. Fully Tempered Float Glass: ASTM C 1048, Kind FT (fully tempered), Condition A (uncoated) unless otherwise indicated, Type I, Class 1 (clear) or Class 2 (tinted) as indicated, Quality-Q3.
- C. Heat-Strengthened Float Glass: ASTM C 1048, Kind HS (heat strengthened), Type I, Condition A (uncoated) unless otherwise indicated, Type I, Class 1 (clear) or Class 2 (tinted) as indicated, Quality-Q3.

## 2.5 INSULATING GLASS

- A. Insulating-Glass Units: Factory-assembled units consisting of sealed lites of glass separated by a dehydrated interspace, qualified according to ASTM E 2190.
  - 1. Sealing System: Dual seals.
  - 2. Perimeter Spacer: Aluminum with mill or clear anodic finish Thermally broken aluminum.

## 2.6 GLAZING SEALANTS

- A. General:
  - 1. Compatibility: Compatible with one another and with other materials they contact, including glass products, seals of insulating-glass units, and glazing channel substrates, under conditions of service and application, as demonstrated by sealant manufacturer based on testing and field experience.
  - 2. Suitability: Comply with sealant and glass manufacturers' written instructions for selecting glazing sealants suitable for applications indicated and for conditions existing at time of installation.
  - 3. Colors of Exposed Glazing Sealants: As selected by Architect from manufacturer's full range.
- B. Glazing Sealant: Neutral-curing silicone glazing sealant complying with ASTM C 920, Type S, Grade NS, Class 50, Use NT.

## 2.7 GLAZING TAPES

- A. Back-Bedding Mastic Glazing Tapes: Preformed, butyl-based, 100 percent solids elastomeric tape; nonstaining and nonmigrating in contact with nonporous surfaces; with or without spacer



rod as recommended in writing by tape and glass manufacturers for application indicated; and complying with ASTM C 1281 and AAMA 800 for products indicated below:

1. AAMA 806.3 tape, for glazing applications in which tape is subject to continuous pressure.
- B. Expanded Cellular Glazing Tapes: Closed-cell, PVC foam tapes; factory coated with adhesive on both surfaces; and complying with AAMA 800 for the following types:
  1. AAMA 810.1, Type 1, for glazing applications in which tape acts as the primary sealant.

## 2.8 MISCELLANEOUS GLAZING MATERIALS

- A. Cleaners, Primers, and Sealers: Types recommended by sealant or gasket manufacturer.
- B. Setting Blocks: Elastomeric material with a Shore, Type A durometer hardness of 85, plus or minus 5.
- C. Spacers: Elastomeric blocks or continuous extrusions of hardness required by glass manufacturer to maintain glass lites in place for installation indicated.
- D. Edge Blocks: Elastomeric material of hardness needed to limit glass lateral movement (side walking).

## PART 3 - EXECUTION

### 3.1 GLAZING, GENERAL

- A. Comply with combined written instructions of manufacturers of glass, sealants, gaskets, and other glazing materials, unless more stringent requirements are indicated, including those in referenced glazing publications.
- B. Protect glass edges from damage during handling and installation. Remove damaged glass from Project site and legally dispose of off Project site. Damaged glass includes glass with edge damage or other imperfections that, when installed, could weaken glass, impair performance, or impair appearance.
- C. Apply primers to joint surfaces where required for adhesion of sealants, as determined by preconstruction testing.
- D. Install setting blocks in sill rabbets, sized and located to comply with referenced glazing publications, unless otherwise required by glass manufacturer. Set blocks in thin course of compatible sealant suitable for heel bead.
- E. Do not exceed edge pressures stipulated by glass manufacturers for installing glass lites.
- F. Provide spacers for glass lites where length plus width is larger than 50 inches.
- G. Provide edge blocking where indicated or needed to prevent glass lites from moving sideways in glazing channel, as recommended in writing by glass manufacturer and according to requirements in referenced glazing publications.

### 3.2 TAPE GLAZING

- A. Position tapes on fixed stops so that, when compressed by glass, their exposed edges are flush with or protrude slightly above sightline of stops.
- B. Install tapes continuously, but not necessarily in one continuous length. Do not stretch tapes to make them fit opening.
- C. Cover vertical framing joints by applying tapes to heads and sills first, then to jambs. Cover horizontal framing joints by applying tapes to jambs, then to heads and sills.
- D. Place joints in tapes at corners of opening with adjoining lengths butted together, not lapped. Seal joints in tapes with compatible sealant approved by tape manufacturer.
- E. Center glass lites in openings on setting blocks, and press firmly against tape by inserting dense compression gaskets formed and installed to lock in place against faces of removable stops. Start gasket applications at corners and work toward centers of openings.
- F. Apply cap bead of elastomeric sealant over exposed edge of tape where required.

### 3.3 GASKET GLAZING (DRY)

- A. Cut compression gaskets to lengths recommended by gasket manufacturer to fit openings exactly, with allowance for stretch during installation.
- B. Insert soft compression gasket between glass and frame or fixed stop so it is securely in place with joints miter cut and bonded together at corners.
- C. Installation with Drive-in Wedge Gaskets: Center glass lites in openings on setting blocks, and press firmly against soft compression gasket by inserting dense compression gaskets formed and installed to lock in place against faces of removable stops. Start gasket applications at corners and work toward centers of openings. Compress gaskets to produce a weathertight seal without developing bending stresses in glass. Seal gasket joints with sealant recommended by gasket manufacturer.
- D. Installation with Pressure-Glazing Stops: Center glass lites in openings on setting blocks, and press firmly against soft compression gasket. Install dense compression gaskets and pressure-glazing stops, applying pressure uniformly to compression gaskets. Compress gaskets to produce a weathertight seal without developing bending stresses in glass. Seal gasket joints with sealant recommended by gasket manufacturer.
- E. Install gaskets so they protrude past face of glazing stops.

### 3.4 CLEANING AND PROTECTION

- A. Immediately after installation remove nonpermanent labels and clean surfaces.
- B. Protect glass from contact with contaminating substances resulting from construction operations. Examine glass surfaces adjacent to or below exterior concrete surfaces at frequent intervals during construction, but not less than once a month, for buildup of dirt, scum, alkaline deposits, or stains.
  - 1. If, despite such protection, contaminating substances do come into contact with glass, remove substances immediately as recommended in writing by glass manufacturer. Remove and replace glass that cannot be cleaned without damage to coatings.

- C. Remove and replace glass that is damaged during construction period.

### 3.5 GLASS SCHEDULE

#### A. MONOLITHIC GLASS SCHEDULE

- 1. Glass Type 1: Clear fully tempered float glass.
  - a. Minimum Thickness: 1/4 inch.
  - b. Retain subparagraph below if required; "fully tempered" option must be retained in paragraph above if safety glazing is required.
  - c. Safety glazing required.

### 3.6 INSULATING GLASS SCHEDULE

#### A. Glass Type 2: Clear insulating glass.

- 1. Overall Unit Thickness: 1 inch.
- 2. Minimum Thickness of Each Glass Lite: 1/4 inch.
- 3. Outdoor Lite: Fully tempered float glass.
- 4. Interspace Content: Air.
- 5. Indoor Lite: Fully tempered float glass.
- 6. Safety glazing required.

#### B. Glass Type 3: Reflective-coated, insulating glass.

- 1. Coating Type: Pyrolytic.
- 2. Coating Color: Gold, Pewter, or Silver, to be selected by Architect.
- 3. Overall Unit Thickness: **1 inch**.
- 4. Minimum Thickness of Each Glass Lite: 1/4 inch.
- 5. Outdoor Lite: Clear float glass.
- 6. Interspace Content: Air.
- 7. Indoor Lite: Clear annealed float glass.
- 8. Coating Location: Second surface.

**END OF SECTION 08 8000**

## **SECTION 09 29 00 - GYPSUM BOARD**

### **PART 1 - GENERAL**

#### **1.1 SUMMARY**

- A. Section Includes:
  - 1. Interior gypsum board.
  - 2. Exterior gypsum board.

#### **1.2 ACTION SUBMITTALS**

- A. Product Data: For each type of product.
- B. Samples: For each texture finish indicated on same backing indicated for Work.

### **PART 2 - PRODUCTS**

#### **2.1 PERFORMANCE REQUIREMENTS**

- A. Fire-Resistance-Rated Assemblies: For fire-resistance-rated assemblies, provide materials and construction identical to those tested in assembly indicated according to ASTM E 119 by an independent testing agency.
- B. STC-Rated Assemblies: For STC-rated assemblies, provide materials and construction identical to those tested in assembly indicated according to ASTM E 90 and classified according to ASTM E 413 by an independent testing agency.

#### **2.2 GYPSUM BOARD, GENERAL**

- A. Size: Provide maximum lengths and widths available that will minimize joints in each area and that correspond with support system indicated

#### **2.3 INTERIOR GYPSUM BOARD**

- A. Gypsum Board, Type X: ASTM C 1396/C 1396M.
  - 1. Thickness: 5/8 inch.
  - 2. Long Edges: Tapered.
- B. Gypsum Ceiling Board: ASTM C 1396/C 1396M.
  - 1. Thickness: 5/8 inch.
  - 2. Long Edges: Tapered.
- C. EXTERIOR GYPSUM BOARD
- D. Glass-Mat Gypsum Sheathing Board, Type X: ASTM C 1177/C 1177M, with fiberglass mat laminated to both sides and with manufacturer's standard edges.
- E. Glass-Mat Gypsum Sheathing Board: ASTM C 1177/C 1177M, with fiberglass mat laminated to both sides and with manufacturer's standard edges.

1. Thickness: 1/2 inch

F. TRIM ACCESSORIES

G. Interior Trim: ASTM C 1047.

1. Material: Galvanized or aluminum-coated steel sheet, rolled zinc, plastic, or paper-faced galvanized-steel sheet.
2. Shapes:
  - a. Cornerbead.
  - b. LC-Bead: J-shaped; exposed long flange receives joint compound.
  - c. L-Bead: L-shaped; exposed long flange receives joint compound.
  - d. Expansion (control) joint.

H. Exterior Trim: ASTM C 1047.

1. Material: Hot-dip galvanized-steel sheet, plastic, or rolled zinc.
2. Shapes:
  - a. Cornerbead.
  - b. LC-Bead: J-shaped; exposed long flange receives joint compound.
  - c. Expansion (Control) Joint: One-piece, rolled zinc with V-shaped slot and removable strip covering slot opening.

2.4 JOINT TREATMENT MATERIALS

A. General: Comply with ASTM C 475/C 475M.

B. Joint Tape:

1. Interior Gypsum Board: Paper.
2. Glass-Mat Gypsum Sheathing Board: 10-by-10 glass mesh.

C. Joint Compound for Interior Gypsum Board: For each coat, use formulation that is compatible with other compounds applied on previous or for successive coats.

2.5 AUXILIARY MATERIALS

A. General: Provide auxiliary materials that comply with referenced installation standards and manufacturer's written instructions.

B. Drywall Screws: ASTM C 1002 unless otherwise indicated.

1. Use screws complying with ASTM C 954 for fastening panels to wood members from 1 1/2" thick.

C. Sound-Attenuation Blankets: ASTM C 665, Type I (blankets without membrane facing) produced by combining thermosetting resins with mineral fibers manufactured from glass, slag wool, or rock wool.

1. Fire-Resistance-Rated Assemblies: Comply with mineral-fiber requirements of assembly.

D. Thermal Insulation: As specified in Section 07 21 00 "Thermal Insulation."

PART 3 - EXECUTION

3.1 APPLYING AND FINISHING PANELS

- A. Examine panels before installation. Reject panels that are wet, moisture damaged, and mold damaged.
- B. Comply with ASTM C 840.
- C. Isolate perimeter of gypsum board applied to non-load-bearing partitions at structural abutments. Provide 1/4 to 1/2-inch- wide spaces at these locations and trim edges with edge trim where edges of panels are exposed. Seal joints between edges and abutting structural surfaces with acoustical sealant.
- D. For trim with back flanges intended for fasteners, attach to framing with same fasteners used for panels. Otherwise, attach trim according to manufacturer's written instructions.
- E. Prefill open joints, rounded or beveled edges, and damaged surface areas.
- F. Apply joint tape over gypsum board joints, except for trim products specifically indicated as not intended to receive tape.
- G. Gypsum Board Finish Levels: Finish panels to levels indicated below and according to ASTM C 840:
  - 1. Level 3: Panels that are substrate for storage, mechanical/electrical, custodial, concealed areas, and where indicated.
  - 2. Level 4: At all other new or existing panel surfaces exposed to view, unless otherwise indicated.

3.2 PROTECTION

- A. Protect installed products from damage from weather, condensation, direct sunlight, construction, and other causes during remainder of the construction period.
- B. Remove and replace panels that are wet, moisture damaged, and mold damaged.

**END OF SECTION 09 29 00**

## **SECTION 09 51 13 - ACOUSTICAL PANEL CEILINGS**

### **PART 1 - GENERAL**

#### **1.1 SUMMARY**

- A. Section includes
  - 1. Acoustical panels and exposed suspension systems for interior ceilings.

#### **1.2 ACTION SUBMITTALS**

- A. Product Data: For each type of product.
- B. Samples: For each exposed product and for each color and texture specified.
- C. Delegated-Design Submittal: For seismic restraints for ceiling systems.
  - 1. Include design calculations for seismic restraints including analysis data signed and sealed by the qualified professional engineer responsible for their preparation.

#### **1.3 INFORMATIONAL SUBMITTALS**

- A. Coordination Drawings: Reflected ceiling plans, drawn to scale, and coordinated with each other, using input from installers of the items involve, showing all items penetrating finished ceiling, including but not limited to the following:
  - 1. Lighting Fixtures
  - 2. Air Outlets & inlets
  - 3. Motion Detectors
  - 4. Access Panels
  - 5. Cameras
- B. Product test reports.
- C. Research reports.
- D. Field quality-control reports.

#### **1.4 CLOSEOUT SUBMITTALS**

- A. Extra material: Provide owner with two cartons of each type of tile for future use.
- B. Maintenance data.

### **PART 2 - PRODUCTS**

#### **2.1 PERFORMANCE REQUIREMENTS**

- A. Seismic Performance: Suspended ceilings shall withstand the effects of earthquake motions determined according to ASCE/SEI 7.
- B. Surface-Burning Characteristics: Comply with ASTM E 84; testing by a qualified testing agency. Identify products with appropriate markings of applicable testing agency.

1. Flame-Spread Index: Class A according to ASTM E 1264.
2. Smoke-Developed Index: 50 or less.

## 2.2 ACOUSTICAL PANELS

- A. Acoustical Panel Standard: Manufacturer's standard panels according to ASTM E 1264.
- B. Manufacturers: Subject to compliance with requirements, available manufacturers offering products that may be incorporated into the work include, but are not limited the Basis of Design products indicated in the Drawings.
- C. Basis of Design: USG 2310
- D. Color: White.
- E. Light Reflectance (LR): 0.85.
- F. Ceiling Attenuation Class (CAC): 35.
- G. Noise Reduction Coefficient (NRC): 0.75.
- H. Edge/Joint Detail: As indicated in drawings.
- I. Thickness: 7/8 inch or as indicated.
- J. Modular Size: 24 by 48 inches or as indicated.

## 2.3 METAL SUSPENSION SYSTEM

- A. Metal Suspension-System Standard: Manufacturer's standard, direct-hung, metal suspension system and accessories according to ASTM C 635/C 635M.
- B. Narrow-Face, Capped, Double-Web, Steel Suspension System: Main and cross runners roll formed from cold-rolled steel sheet; prepainted, electrolytically zinc coated, or hot-dip galvanized, G30 coating designation; with prefinished 9/16-inch- wide metal caps on flanges.
  1. Structural Classification: Intermediate duty system.
  2. End Condition of Cross Runners: Override (stepped).
  3. Face Design: Flat, flush.
  4. Cap Material: Cold-rolled steel.
  5. Cap Finish: Painted white.

## 2.4 ACCESSORIES

- A. Attachment Devices: Size for five times the design load indicated in ASTM C 635/C 635M, Table 1, "Direct Hung," unless otherwise indicated. Comply with seismic design requirements.
- B. Seismic Clips: Manufacturer's standard seismic clips designed to secure acoustical panels in place during a seismic event.

## 2.5 METAL EDGE MOLDINGS AND TRIM

- A. Roll-Formed, Sheet-Metal Edge Moldings and Trim: Type and profile indicated or, if not indicated, manufacturer's standard moldings for edges and penetrations that comply with



seismic design requirements; formed from sheet metal of same material, finish, and color as that used for exposed flanges of suspension-system runners.

- B. Extruded aluminum perimeter trim around suspended ceiling clouds.
  - 1. Height: 2".
  - 2. Color: To match metal suspension system.
- C. Extruded aluminum column ring, sized to coordinate with item penetrating ceiling, as indicated on drawings.

### PART 3 - EXECUTION

#### 3.1 PREPARATION

- A. Measure each ceiling area and establish layout of acoustical panels to balance border widths at opposite edges of each ceiling. Avoid using less-than-half-width panels at borders unless otherwise indicated.
- B. Layout openings for penetrations centered on the penetrating items.

#### 3.2 INSTALLATION

- A. Install acoustical panel ceilings according to ASTM C 636/C 636M, seismic design requirements, and manufacturer's written instructions.
- B. Install edge moldings and trim of type indicated at perimeter of acoustical ceiling area and where necessary to conceal edges of acoustical panels.
  - 1. Retain subparagraphs below to eliminate air movement and light and sound leaks at edges of ceiling.
  - 2. Apply acoustical sealant in a continuous ribbon concealed on back of vertical legs of moldings before they are installed.
  - 3. Do not use exposed fasteners, including pop rivets, on moldings and trim.
  - 4. Arrange directionally patterned acoustical panels as follows:
    - a. As indicated on reflected ceiling plans.
  - 5. Install seismic clips as required to meet Performance Requirements; space according to panel manufacturer's written instructions unless otherwise indicated.

#### 3.3 FIELD QUALITY CONTROL

- A. Special Inspections: Owner will engage a qualified special inspector to perform inspections.
  - 1. Periodic inspection during the installation of suspended ceiling grids according to ASCE/SEI 7.

### END OF SECTION 09 51 13

## PART 1 - GENERAL

### 1.1 SUMMARY

- A. Section Includes:
  - 1. Thermoset-rubber base.
  - 2. Rubber molding accessories.

### 1.2 ACTION SUBMITTALS

- A. Product Data: For each type of product.
- B. Samples: For each exposed product and for each color and texture specified.

## PART 2 - PRODUCTS

### 2.1 THERMOSET-RUBBER BASE

- A. Manufacturers: Subject to compliance with requirements, available manufacturers offering products that may be incorporated into the work include, but are not limited the Basis of Design products indicated in the Drawings.
- B. Basis of Design: Johnsonite Baseworks
- C. Product Standard: ASTM F 1861, Type TS (rubber, vulcanized thermoset), Group I (solid, homogeneous).
  - 1. Style and Location:
    - a. Style A, Straight: Provide throughout, as designated in drawings. .
- D. Thickness: 0.125 inch.
- E. Height: As indicated on Drawings.
- F. Lengths: Coils in manufacturer's standard length.
- G. Outside Corners: Job formed for non-standard angled corners, pre-formed at 90 degree corners.
- H. Inside Corners: Job formed for non-standard angled corners, pre-formed at 90 degree corners.

### 2.2 RUBBER MOLDING ACCESSORY

- A. Single source: Use same manufacturer as Rubber Base.
- B. Description: Rubber reducer strip for resilient floor covering and transition strips.
- C. Profile and Dimensions: As indicated on Drawings.
- D. Locations: Provide rubber molding accessories in areas indicated and as needed.

## 2.3 INSTALLATION MATERIALS

- A. Trowelable Leveling and Patching Compounds: Latex-modified, portland-cement-based or blended hydraulic-cement-based formulation provided or approved by resilient-product manufacturer for applications indicated.
- B. Adhesives: Water-resistant type recommended by resilient-product manufacturer for resilient products and substrate conditions indicated.

## PART 3 - EXECUTION

### 3.1 PREPARATION

- A. Prepare substrates according to manufacturer's written instructions to ensure adhesion of resilient products.
- B. Fill cracks, holes, and depressions in substrates with trowelable leveling and patching compound; remove bumps and ridges to produce a uniform and smooth substrate.
- C. Do not install resilient products until materials are the same temperature as space where they are to be installed.
- D. Immediately before installation, sweep and vacuum clean substrates to be covered by resilient products.

### 3.2 RESILIENT BASE INSTALLATION

- A. Comply with manufacturer's written instructions for installing resilient base.
- B. Apply resilient base to walls, columns, pilasters, casework and cabinets in toe spaces, and other permanent fixtures in rooms and areas where base is required.
- C. Install resilient base in lengths as long as practical without gaps at seams and with tops of adjacent pieces aligned.
- D. Tightly adhere resilient base to substrate throughout length of each piece, with base in continuous contact with horizontal and vertical substrates.
- E. Do not stretch resilient base during installation.
- F. Preformed Corners: Install preformed corners before installing straight pieces.
- G. Job-Formed Corners:
  - 1. Outside Corners: Use straight pieces of maximum lengths possible and form with returns not less than 3 inches in length.
    - a. Form without producing discoloration (whitening) at bends.
  - 2. Inside Corners: Use straight pieces of maximum lengths possible and form with returns not less than 3 inches in length.
    - a. Miter or cope corners to minimize open joints.

### 3.3 RESILIENT ACCESSORY INSTALLATION

- A. Comply with manufacturer's written instructions for installing resilient accessories.

- B. Resilient Molding Accessories: Butt to adjacent materials and tightly adhere to substrates throughout length of each piece. Install reducer strips at edges of floor covering that would otherwise be exposed.

3.4 CLEANING AND PROTECTION

- A. Comply with manufacturer's written instructions for cleaning and protecting resilient products.
- B. Cover resilient products subject to wear and foot traffic until Substantial Completion.

**END OF SECTION 09 65 13**

**SECTION 09 65 16 - RESILIENT SHEET FLOORING**

**PART 1 - GENERAL**

**1.1 RELATED DOCUMENTS**

- A. Drawings and general provisions of the Contract, including General and Supplementary Conditions and Division 01 Specification Sections, apply to this Section.

**1.2 SUMMARY**

- A. Section includes vinyl sheet flooring.

**1.3 ACTION SUBMITTALS**

- A. Product Data: For each type of product.
- B. Sustainable Design Submittals:
- C. Shop Drawings: For each type of flooring. Include flooring layouts, locations of seams, edges, columns, doorways, enclosing partitions, built-in furniture, cabinets, and cutouts.
  - 1. Show details of special patterns.
- D. Samples: For each exposed product and for each color and texture specified in manufacturer's standard size, but not less than 6-by-9-inch sections.
  - 1. For heat-welding bead, manufacturer's standard-size Samples, but not less than 9 inches long, of each color required.
- E. Samples for Initial Selection: For each type of resilient sheet flooring indicated.
- F. Samples for Verification: In manufacturer's standard size, but not less than 6-by-9-inch sections of each different color and pattern of resilient sheet flooring required.

**1.4 INFORMATIONAL SUBMITTALS**

- A. Qualification Data: For Installer.

**1.5 CLOSEOUT SUBMITTALS**

- A. Maintenance Data: For each type of resilient sheet flooring to include in maintenance manuals.

**1.6 MAINTENANCE MATERIAL SUBMITTALS**

- A. Furnish extra materials that match products installed and that are packaged with protective covering for storage and identified with labels describing contents.
  - 1. Resilient Sheet Flooring: Furnish not less than 10 linear feet for every 500 linear or fraction thereof, in roll form and in full roll width for each type, color, and pattern of flooring installed.

1.7 QUALITY ASSURANCE

- A. Installer Qualifications: A qualified installer who employs workers for this Project who are competent in techniques required by manufacturer for resilient sheet flooring installation and seaming method indicated.
  - 1. Engage an installer who employs workers for this Project who are trained or certified by resilient sheet flooring manufacturer for installation techniques required.

1.8 DELIVERY, STORAGE, AND HANDLING

- A. Store resilient sheet flooring and installation materials in dry spaces protected from the weather, with ambient temperatures maintained within range recommended by manufacturer, but not less than 50 deg For more than 90 deg F. Store rolls upright.

1.9 FIELD CONDITIONS

- A. Maintain ambient temperatures within range recommended by manufacturer, but not less than 70 deg For more than 85 deg Fin spaces to receive resilient sheet flooring during the following time periods:
  - 1. 48 hours before installation.
  - 2. During installation.
  - 3. 48 hours after installation.
- B. After installation and until Substantial Completion, maintain ambient temperatures within range recommended by manufacturer, but not less than 55 deg For more than 95 deg F.
- C. Close spaces to traffic during resilient sheet flooring installation.
- D. Close spaces to traffic for 48 hours after resilient sheet flooring installation.
- E. Install resilient sheet flooring after other finishing operations, including painting, have been completed.

PART 2 - PRODUCTS

2.1 PERFORMANCE REQUIREMENTS

- A. Fire-Test-Response Characteristics: For resilient sheet flooring, as determined by testing identical products according to ASTM E 648 or NFPA 253 by a qualified testing agency.
  - 1. Critical Radiant Flux Classification: Class I, not less than 0.45 W/sq. cm.

2.2 VINYL SHEET FLOORING WITH BACKING: SVF1

- A. Product Standard: ASTM 1303.
  - 1. Type (Binder Content): Type I, minimum binder content or 90 percent.
  - 2. Wear-Layer Thickness: Grade 1.
  - 3. Overall Thickness: As standard with manufacturer.
  - 4. Interlayer Material: None
  - 5. Backing Class: Class B (nonfoamed plastic).
- B. Wearing Surface: Smooth

- C. Sheet Width: As standard with manufacturer.
- D. Seamless-Installation Method: Chemically bonded.
- E. Colors and Patterns: As noted on Drawings.

### 2.3 INSTALLATION MATERIALS

- A. Trowelable Leveling and Patching Compounds: Latex-modified, portland cement based or blended hydraulic-cement-based formulation provided or approved by resilient sheet flooring manufacturer for applications indicated.
- B. Adhesives: Water-resistant type recommended by flooring and adhesive manufacturers to suit resilient sheet flooring and substrate conditions indicated.
- C. Seamless-Installation Accessories:
  - 1. Chemical-Bonding Compound: Manufacturer's product for chemically bonding seams.
- D. Integral-Flash-Cove-Base Accessories:
  - 1. Cove Strip: 1-inch radius provided or approved by resilient sheet flooring manufacturer.
  - 2. Cap Strip: Square Metal, provided or approved by resilient sheet flooring manufacturer.
  - 3. Corners: Metal inside and outside corners and end stops provided or approved by resilient sheet flooring manufacturer.
- E. Floor Polish: Provide protective, liquid floor-polish products recommended by resilient sheet flooring manufacturer.

## PART 3 - EXECUTION

### 3.1 EXAMINATION

- A. Examine substrates, with Installer present, for compliance with requirements for maximum moisture content and other conditions affecting performance of the Work.
  - 1. Verify that finishes of substrates comply with tolerances and other requirements specified in other Sections and that substrates are free of cracks, ridges, depressions, scale, and foreign deposits that might interfere with adhesion of resilient sheet flooring.
- B. Proceed with installation only after unsatisfactory conditions have been corrected.

### 3.2 PREPARATION

- A. Prepare substrates according to resilient sheet flooring manufacturer's written instructions to ensure adhesion of resilient sheet flooring.
- B. Concrete Substrates: Prepare according to ASTM F 710.
  - 1. Verify that substrates are dry and free of curing compounds, sealers, and hardeners.
  - 2. Remove substrate coatings and other substances that are incompatible with adhesives and that contain soap, wax, oil, or silicone, using mechanical methods recommended by resilient sheet flooring manufacturer. Do not use solvents.
  - 3. Alkalinity and Adhesion Testing: Perform tests recommended by resilient sheet flooring manufacturer. Proceed with installation only after substrate alkalinity falls within range on

- pH scale recommended by manufacturer in writing, but not less than 5 or more than 9 pH.
4. Moisture Testing: Proceed with installation only after substrates pass testing according to resilient sheet flooring manufacturer's written recommendations, but not less stringent than the following:
    - a. Perform anhydrous calcium chloride test according to ASTM F 1869. Proceed with installation only after substrates have maximum moisture-vapor-emission rate of 3 lb of water/1000 sq. ft.in 24 hours.
    - b. Perform relative humidity test using in situ probes according to ASTM F 2170. Proceed with installation only after substrates have a maximum 75 percent relative humidity level.
  - C. Fill cracks, holes, and depressions in substrates with trowelable leveling and patching compound; remove bumps and ridges to produce a uniform and smooth substrate.
  - D. Do not install resilient sheet flooring until it is the same temperature as the space where it is to be installed.
    1. At least 48 hours in advance of installation, move flooring and installation materials into spaces where they will be installed.
  - E. Immediately before installation, sweep and vacuum clean substrates to be covered by resilient sheet flooring.

### 3.3 RESILIENT SHEET FLOORING INSTALLATION

- A. Comply with manufacturer's written instructions for installing resilient sheet flooring.
- B. Unroll resilient sheet flooring and allow it to stabilize before cutting and fitting.
- C. Lay out resilient sheet flooring as follows:
  1. Maintain uniformity of flooring direction.
  2. Minimize number of seams; place seams in inconspicuous and low-traffic areas, at least 6 inches away from parallel joints in flooring substrates.
  3. Match edges of flooring for color shading at seams.
  4. Avoid cross seams.
- D. Scribe and cut resilient sheet flooring to butt neatly and tightly to vertical surfaces, permanent fixtures, and built-in furniture including cabinets, pipes, outlets, and door frames.
- E. Extend resilient sheet flooring into toe spaces, door reveals, closets, and similar openings.
- F. Maintain reference markers, holes, and openings that are in place or marked for future cutting by repeating on resilient sheet flooring as marked on substrates. Use chalk or other nonpermanent marking device.
- G. Install resilient sheet flooring on covers for telephone and electrical ducts and similar items in installation areas. Maintain overall continuity of color and pattern between pieces of flooring installed on covers and adjoining flooring. Tightly adhere flooring edges to substrates that abut covers and to cover perimeters.



- H. Adhere resilient sheet flooring to substrates using a full spread of adhesive applied to substrate to produce a completed installation without open cracks, voids, raising and puckering at joints, telegraphing of adhesive spreader marks, and other surface imperfections.
- I. Seamless Installation:
  - 1. Heat-Welded Seams: Comply with ASTM F 1516. Rout joints and heat weld with welding bead to permanently fuse sections into a seamless flooring. Prepare, weld, and finish seams to produce surfaces flush with adjoining flooring surfaces.
  - 2. Chemically Bonded Seams: Bond seams with chemical-bonding compound to permanently fuse sections into a seamless flooring. Prepare seams and apply compound to produce tightly fitted seams without gaps, overlays, or excess bonding compound on flooring surfaces.
- J. Integral-Flash-Cove Base: Cove resilient sheet flooring 6 inches up vertical surfaces. Support flooring at horizontal and vertical junction with cove strip. Butt at top against cap strip.
  - 1. Install metal corners at inside and outside corners.

### 3.4 CLEANING AND PROTECTION

- A. Comply with manufacturer's written instructions for cleaning and protecting resilient sheet flooring.
- B. Perform the following operations immediately after completing resilient sheet flooring installation:
  - 1. Remove adhesive and other blemishes from surfaces.
  - 2. Sweep and vacuum surfaces thoroughly.
  - 3. Damp-mop surfaces to remove marks and soil.
- C. Protect resilient sheet flooring from marks, marks, indentations, and other damage from construction operations and placement of equipment and fixtures during remainder of construction period.
- D. Cover resilient sheet flooring until Substantial Completion.

**END OF SECTION 09 65 16**

**SECTION 09 68 13 - TILE CARPETING**

**PART 1 - GENERAL**

**1.1 SUMMARY**

- A. Section includes modular carpet tile.

**1.2 ACTION SUBMITTALS**

- A. Product Data: For each type of product.
- B. Shop Drawings: For carpet tile installation, plans showing the following:
  - 1. Columns, doorways, enclosing walls or partitions, built-in cabinets, and locations where cutouts are required in carpet tiles.
  - 2. Carpet tile type, color, and dye lot.
  - 3. Type of subfloor.
  - 4. Type of installation.
  - 5. Pattern of installation.
  - 6. Pattern type, location, and direction.
  - 7. Pile direction.
  - 8. Type, color, and location of edge, transition, and other accessory strips.
  - 9. Transition details to other flooring materials.
- C. Samples: For each exposed product and for each color and texture required.

**1.3 INFORMATIONAL SUBMITTALS**

- A. Product test reports.
- B. Sample warranty.

**1.4 CLOSEOUT SUBMITTALS**

- A. Maintenance data.
- B. Provide 3% extra full unopened (one unopened box minimum) boxes of each carpet tile color and pattern from the same dye lot / run of installed tiles.

**1.5 QUALITY ASSURANCE**

- A. Installer Qualifications: Certified by the International Certified Floorcovering Installers Association at the Commercial II certification level.

**1.6 WARRANTY**

- A. Special Warranty for Carpet Tiles: Manufacturer agrees to repair or replace components of carpet tile installation that fail in materials or workmanship within specified warranty period.
  - 1. See Section 01 77 00 CLOSEOUT PROCEDURES.
  - 2. Warranty Period: 10 years from date of Substantial Completion.

## PART 2 - PRODUCTS

### 2.1 CARPET TILE

- A. Manufacturer: Subject to compliance with requirements, available manufacturers offering products that may be incorporated into the work include, but are not limited the Basis of Design products indicated in the Drawings.
- B. Basis of Design: As indicated in Drawings
- C. Color: As indicated in Drawings.
- D. Pattern: As indicated in Drawings.
- E. Backing/Backcoating:
  - 1. TractionBack: cushioned PVC-free backing requiring no adhesive for installation.
  - 2. Ecoworx: PVC free backing.
- F. Size: As indicated in drawings.

### 2.2 INSTALLATION ACCESSORIES

- A. Trowelable Leveling and Patching Compounds: Latex-modified, hydraulic-cement-based formulation provided or recommended by carpet tile manufacturer.

## PART 3 - EXECUTION

### 3.1 EXAMINATION

- A. Concrete Slabs:
  - 1. Moisture Testing: Perform tests so that each test area does not exceed 200 sq. ft., and perform no fewer than three tests in each installation area and with test areas evenly spaced in installation areas.
    - a. Anhydrous Calcium Chloride Test: ASTM F 1869. Proceed with installation only after substrates have maximum moisture-vapor-emission rate of 3 lb of water/1000 sq. ft. in 24 hours.
    - b. Relative Humidity Test: Using in situ probes, ASTM F 2170. Proceed with installation only after substrates have a maximum 75 percent relative humidity level measurement.
    - c. Perform additional moisture tests recommended in writing by adhesive and carpet tile manufacturers. Proceed with installation only after substrates pass testing.
- B. Subfloors: Verify that underlayment surface is free of irregularities and substances that may interfere with adhesive bond or show through surface.

### 3.2 PREPARATION

- A. General: Comply with CRI's "CRI Carpet Installation Standards" and with carpet tile manufacturer's written installation instructions for preparing substrates indicated to receive carpet tile.
- B. Use trowelable leveling and patching compounds, according to manufacturer's written instructions, to fill cracks, holes, depressions, and protrusions in substrates. Fill or level cracks,

holes and depressions 1/8 inch wide or wider, and protrusions more than 1/32 inch unless more stringent requirements are required by manufacturer's written instructions.

- C. Concrete Substrates: Remove coatings, including curing compounds, and other substances that are incompatible with adhesives and that contain soap, wax, oil, or silicone, without using solvents. Use mechanical methods recommended in writing by adhesive and carpet tile manufacturers.
- D. Broom and vacuum clean substrates to be covered immediately before installing carpet tile.

### 3.3 INSTALLATION

- A. General: Comply with CRI's "CRI Carpet Installation Standard," Section 18, "Modular Carpet" and with carpet tile manufacturer's written installation instructions.
- B. Installation Method: Non-adhesive, as recommended in writing by carpet tile manufacturer.
- C. Maintain dye-lot integrity. Do not mix dye lots in same area.
- D. Maintain pile-direction patterns indicated on Drawings.
- E. Cut and fit carpet tile to butt tightly to vertical surfaces, permanent fixtures, and built-in furniture including cabinets, pipes, outlets, edgings, thresholds, and nosings. Bind or seal cut edges as recommended by carpet tile manufacturer.
- F. Extend carpet tile into toe spaces, door reveals, closets, open-bottomed obstructions, removable flanges, alcoves, and similar openings.
- G. Access Flooring: Stagger joints of carpet tiles so carpet tile grid is offset from access flooring panel grid. Do not fill seams of access flooring panels with carpet adhesive; keep seams free of adhesive.
- H. Protect carpet tile against damage from construction operations and placement of equipment and fixtures during the remainder of construction period. Use protection methods indicated or recommended in writing by carpet tile manufacturer.

**END OF SECTION 09 68 13**

**SECTION 06 64 00 – FIBERGLASS REINFORCED PANELING (FRP)**

**PART 1 - GENERAL**

**1.1 RELATED DOCUMENTS**

- A. Drawings and general provisions of the Contract, including General and Supplementary Conditions and Division 01 Specification Sections, apply to this Section.

**1.2 SUMMARY**

- A. Section Includes:
  - 1. Fiberglass Reinforced Paneling.

**1.3 ACTION SUBMITTALS**

- A. Product Data: For each type of product.
- B. Samples: For plastic paneling and trim accessories, in manufacturer's standard sizes.

**1.4 PROJECT CONDITIONS**

- A. Environmental Limitations: Do not deliver or install plastic paneling until spaces are enclosed and weathertight and temporary HVAC system is operating and maintaining ambient temperature and humidity conditions at occupancy levels during the remainder of the construction period.

**PART 2 - PRODUCTS**

**2.1 MANUFACTURERS**

- A. Source Limitations: Obtain plastic paneling and trim accessories from single manufacturer.

**2.2 FIBERGLASS REINFORCED PANELING**

- A. Glass-Fiber-Reinforced Plastic Paneling: Gelcoat-finished, glass-fiber-reinforced plastic panels complying with ASTM D 5319.
  - 1. Surface-Burning Characteristics: As follows when tested by a qualified testing agency according to ASTM E 84. Identify products with appropriate markings of applicable testing agency.
    - a. Flame-Spread Index: 25 or less.
    - b. Smoke-Developed Index: 450 or less.
  - 2. Nominal Thickness: Not less than 0.09 inch
  - 3. Surface Finish: Molded pebble texture.
  - 4. Color: As selected by Architect from manufacturer's full range.

### 2.3 ACCESSORIES

- A. Trim Accessories: Manufacturer's standard **one-piece** vinyl extrusions designed to retain and cover edges of panels. Provide division bars, inside corners, outside corners, and caps as needed to conceal edges.
  - 1. Color: Match panels.
- B. Adhesive: As recommended by plastic paneling manufacturer.
- C. Sealant: Mildew-resistant, single-component, neutral-curing silicone sealant recommended by plastic paneling manufacturer and complying with requirements in Section 07 92 00 "Joint Sealants."

## PART 3 - EXECUTION

### 3.1 EXAMINATION

- A. Examine substrates and conditions, with Installer present, for compliance with requirements for installation tolerances and other conditions affecting performance of the Work.
- B. Proceed with installation only after unsatisfactory conditions have been corrected.

### 3.2 PREPARATION

- A. Remove wallpaper, vinyl wall covering, loose or soluble paint, and other materials that might interfere with adhesive bond.
- B. Prepare substrate by sanding high spots and filling low spots as needed to provide flat, even surface for panel installation.
- C. Clean substrates of substances that could impair adhesive bond, including oil, grease, dirt, and dust.
- D. Condition panels by unpacking and placing in installation space before installation according to manufacturer's written recommendations.
- E. Lay out paneling before installing. Locate panel joints to provide equal panels at ends of walls not less than half the width of full panels.
  - 1. Mark plumb lines on substrate at trim accessory locations for accurate installation.
  - 2. Locate trim accessories to allow clearance at panel edges according to manufacturer's written instructions.

### 3.3 INSTALLATION

- A. Install plastic paneling according to manufacturer's written instructions.
- B. Install panels in a full spread of adhesive.
- C. Install trim accessories with adhesive and nails or staples. Do not fasten through panels.
- D. Fill grooves in trim accessories with sealant before installing panels, and bed inside corner trim in a bead of sealant.

- E. Maintain uniform space between panels and wall fixtures. Fill space with sealant.
- F. Maintain uniform space between adjacent panels and between panels and floors, ceilings, and fixtures. Fill space with sealant.
- G. Remove excess sealant and smears as paneling is installed. Clean with solvent recommended by sealant manufacturer and then wipe with clean dry cloths until no residue remains.

**END OF SECTION 06 64 00**

## SECTION 09 77 10 – FIBER REINFORCED LAMINATES

### PART 1 - GENERAL

#### 1.1 RELATED DOCUMENTS

- A. Drawings and general provisions of the Contract, including General Conditions and Division 1 Specification Sections, apply to this Section.

#### 1.2 SUMMARY

- A. This Section includes
  - 1. Fiber reinforced laminates (FRL) for wall applications.
  - 2. Accessories, including adhesives and sealants.

#### 1.3 SUBMITTALS

- A. Product Data: submit manufacturer's literature including product characteristics, accessories and limitations
- B. Selection Samples: Submit samples of colors and finishes
- C. Industry Certifications and Standards: Submit copy of documentation indicating compliance.

#### 1.4 QUALITY ASSURANCE

- A. Installer Qualifications: Minimum of 5 years of experience on similar work; knowledge and understanding of standards referenced herein; skill necessary to perform in compliance with this specification. Installers failing to demonstrate the required experience, knowledge, or skill shall be removed from the project.
- B. Fire-Test-Response Characteristics: ASTM E 84.
  - 1. Flame-Spread Index: 25 or less.
  - 2. Smoke-Developed Index: 50 or less.

#### 1.5 WARRANTY

- A. Provide manufacturer's warranty that products are to be free from defects in materials and workmanship for 5 years beginning at date of acceptance by Owner.
- B. See 01 77 00 CLOSEOUT PROCEDURES for additional Warranty requirements.

#### 1.6 DELIVERY, STORAGE, AND HANDLING

- A. Deliver materials and products in unopened factory labeled packages. Store and handle in strict compliance with manufacturer's instructions and recommendations.

### PART 2 - PRODUCTS.

#### 2.1 Fiber reinforced laminates

- A. Acceptable Manufacturers:
  - 1. Manufacturer: Panolam Industries International, Inc., One Corporate Drive, Suite 725, Shelton, CT 06484. Tel: 203-925-1556. Web: www.panolam.com.



- B. Alternate Manufacturers: No known equals; proposed equals are subject to substitution process per Section 01 25 00 – SUBSTITUTION PROCEDURES.
- C. Panels shall comply with the following:
  - 1. Thickness: 0.075 inches Also available in a sanded back for door applications only (0.062 inches).
  - 2. Color and Finish: As selected by architect from manufacturer's full range of Nevamar or Pionite colors and designs.
  - 3. Surface Burning Characteristics: US Standard UL-723/ASTM E 84 Class A; Canadian Standard ULC-S102 Class A for Surface Burning Characteristics of Building Materials.
  - 4. Sustainability, Indoor Air Quality: GREENGUARD Gold Certification.
  - 5. IMO Certified for marine use.
  - 6. Wear Resistance (Cycles) NEMA 3.13: 3500 typical.
  - 7. Flexural Strength ASTM D790: 20,148 psi typical.
  - 8. Molding Profiles: Outside corners flat, outside corners round, division bars, inside corners, standard end caps.
  - 9. Adhesive: Construction Adhesive #4319 by Franklin Adhesives and Polymers or equal approved by panel manufacturer.
  - 10. Joint Caulking: Color Sil by Color Rite or equal approved by panel manufacturer; 100 percent silicone based colored caulking.

### PART 3 - EXECUTION

#### 3.1 EXAMINATION

- A. Examine substrates for conditions affecting performance of work.
- B. Proceed with installation only after unsatisfactory conditions have been corrected.

#### 3.2 INSTALLATION

- A. Install in conformance with manufacturer's written directions, as shown, and as specified.
- B. Clean substrate of dirt, dust, waxes, and other bond breaking substances prior to beginning installation
- C. Install panels with bottom edge located to clear top of any rigid wall base. Rubber wall bases may be bonded over the FRL using a polymer or urethane based adhesive.
- D. Apply adhesive uniformly using adhesive manufacturers recommended notched trowel to the entire back of panels completely to the edge Install wall covering with no gaps or overlaps, no lifted or curling edges, and no visible shrinkage.
- E. Lay FRL® panels in place leaving approximately 1/8 inch vertical installations 3/16 inch for horizontal installations between panel joints Trim edges and seams for color uniformity, pattern match, and tight closure. Butt seams without any overlay or spacing between strips.
- F. Follow adhesive manufacturer's recommendations for set and application times.
- G. Apply pressure to entire panel face with laminate type roller, removing trapped air and ensure proper adhesion between surfaces
- H. If no trim is used, seal panel joints and top, side, and bottom edges with colored caulking to match panel color. Wipe smooth and remove excess caulk from FRL panel face

#### 3.3 CLEANING

- A. Replace installations out of plumb and not aligned with adjacent panels and construction.

- B. Clean panel face to remove soiling, stains, dust, and dirt using clean rags, and cleaning agents as instructed by manufacturer
- C. Leave installation clean, free of residue and debris resulting from work of this section.

**END SECTION 09 72 00**

## SECTION 09 90 00 – PAINTINGS AND COATINGS

### PART 1 - GENERAL

#### 1.1 RELATED DOCUMENTS

- A. Drawings and general provisions of the Contract, including General Conditions and Division 1 Specification Sections, apply to this Section.

#### 1.2 SUMMARY

- A. This Section includes the following and related work as specified and shown:
  - 1. Paints.
  - 2. Stains.
  - 3. Painting materials.

#### 1.3 SUBMITTALS

- A. Product Data: Submit manufacturer's specifications, data, and installation instructions for review.
  - 1. VOC content of each filler, caulk, primer, sealer, paint and coating.
- B. Samples: Submit 6 minimum 3 x 5-inch minimum samples for each color specified.
  - 1. Field Samples:
    - a. General: In place, on material scheduled to be finished, illustrating coating color, texture and finish. Locate where directed; accepted sample may remain as part of the Work.
    - b. Size: 8'-0" x 8'-0" panel, or 1 entire unit as scheduled to be finished.
- C. Certificates: Submit statement of VOC compliance with local regulations.
- D. Closeout:
  - 1. Extra Stock: Deliver 1% or a minimum of 1 unopened gallon of each color, type and surface texture of paint installed. Label each container with color, type, texture and room locations.
  - 2. Guarantee: Provide completed form per Article 1.5.

#### 1.4 QUALITY ASSURANCE

- A. Reference Standards:
  - 1. American Society of Testing Materials (ASTM): Conform to ASTM D16 for interpretation of terms used in this Section.
  - 2. National Paint and Coatings Association (NPCA): Guide to U.S. Government Paint Specifications.
  - 3. Painting and Decorating Contractors of America (PDCA): Painting - Architectural Specifications Manual.
- B. All fillers, caulks, primers, sealers, paints and coatings shall comply with the VOC limits set forth in the California Green Building Standards Code, Title 24 Part 11. Refer to Section 01 35 63 – CALGREEN REQUIREMENTS.
- C. Qualifications:

1. Applicator: Specializing in performing the work of this Section with minimum 3 years documented experience.
2. Volatile Organic Compounds (VOC): Use only products in compliance with VOC content limits required by state and local regulations.

## 1.5 WARRANTY

- A. Provide in required form for a period of 1 year from date of final acceptance by Owner. Color and finish appearance shall remain unchanged throughout entire guarantee period.
- B. See Section 01 77 00 CLOSEOUT PROCEDURES for additional Warranty requirements.

## PART 2 - PRODUCTS

### 2.1 MANUFACTURERS

- A. Acceptable Paint and Stain Manufacturers.
  1. Dunn-Edwards Paint Corporation
    1. Kelly-Moore Company.
    2. Frazee Industries, Inc.
    3. Sherwin-Williams.
    4. AkzoNobel Glidden Professional (formerly ICI Dulux).
    5. PPG.
    6. American Formulating and Manufacturing (Safecoat).
- B. Alternate Manufacturers: Proposed equals are subject to substitution process per Section 01 25 00 – SUBSTITUTION PROCEDURES.
- C. Container Identification: Identify container with manufacturer's name, and include description of type of paint, brand name, lot number, brand code and color designation.
- D. Paint Materials:
  1. General: Provide ready mixed products, except field catalyzed coatings. Provide accessory materials such as linseed oil, shellac, thinners, cleaners and other materials not specifically indicated but required to achieve finishes specified.
  2. Patching Material: Bondex latex filler.
  3. Caulking Compound: Acrylic Latex manufactured by Tremco Inc., or approved equal.
  4. Primers, Paints and Stains: Refer to Paint Schedules at end of this section for specific product requirements.

### 2.2 MIXING

- A. General: Mix paints at the factory; do not alter or reduce materials except as directed by manufacturer.
- B. Colors: As selected by Architect from manufacturer's full range.]; factory mix match. No tinting of finish coats will be allowed at job site unless specifically approved by Architect. At exterior plaster, primer color shall match paint color.
- C. Mildew Resistance: Add fungicidal agent to paint per manufacturer's recommendations; approximately 4 ounces per gallon. Add agent at the factory; clearly indicate on label that paint is mildew resistant.

## PART 3 - EXECUTION

### 3.1 Examination

- A. General: Examine conditions of surfaces in place before beginning work; report defects.
- B. Shop Applied Primer: Test for compatibility with subsequent cover materials.
- C. Moisture Content:
  - 1. General: Measure moisture content of surfaces using an electronic moisture meter. Do not apply finishes unless moisture content of surfaces are below the following maximums:
    - a. Plaster and Gypsum Wallboard: 12%.
    - b. Masonry, Concrete, and Concrete Unit Masonry: 12%.
    - c. Wood: 15%.
    - d. Concrete Floors: 8%.
  - 2. Acceptance:
    - a. General: Application of first coat of painting process constitutes acceptance of surface.
    - b. Gypsum Board: Inspect after application of seal coat; application of subsequent coat of painting process constitutes acceptance of surface.
- D. Stucco: Allow to dry 30 days minimum before applying elastomeric paint.
- E. Storage:
  - 1. General: Store in properly ventilated separate structure not less than 50'-0" from any other structure on the site.
  - 2. Temperature: Maintain minimum of 45 degrees F and a maximum of 90 degrees F.
  - 3. Fire Prevention: Take necessary precautions to prevent fire; remove paint-soiled rags and waste from building each day or store in metal containers with covers in the paint storage structure.
- F. Protection: Protect adjacent surfaces not scheduled for paint finish from damage resulting from painting operations.
- G. Surface Preparation:
  - 1. General: Remove or mask electrical plates, hardware, light fixture trim, escutcheons, and fittings prior to preparing surfaces or finishing. Correct defects and clean surfaces that affect work of this section. Remove existing coatings that exhibit loose surface conditions. Use Shellac to seal marks that may bleed through surface finishes.
  - 2. Impervious Surfaces: Remove mildew by scrubbing with solution of trisodium phosphate and bleach. Rinse with clean water and allow surface to dry.
  - 3. Aluminum Surfaces Scheduled for Paint Finish: Remove surface contamination by steam or high pressure water. Remove oxidation with acid etch and solvent washing. Apply etching primer immediately following cleaning.
  - 4. Concrete Floors: Remove contamination, acid etch, and rinse floors with clear water. Verify that required acid-alkali balance has been achieved. Allow to dry.
  - 5. Gypsum Board Surfaces: Fill minor defects with filler compound; spot prime defects after repair.
  - 6. Galvanized Surfaces: Remove surface contamination and oils; wash with solvent. Apply coat of etching primer.
  - 7. Concrete and Unit Masonry: Remove dirt, loose mortar, scale, salt or alkali powder, and other foreign matter at surfaces scheduled to receive paint finish. Remove oil and grease with a solution

- of trisodium phosphate; rinse well and allow to dry. Remove stains caused by weathering of corroding metals with a solution of sodium metasilicate after thoroughly wetting with water. Allow to dry.
8. Plaster Surfaces: Fill hairline cracks, small holes, and imperfections with latex patching plaster. Make smooth and flush with adjacent surfaces. Wash and neutralize high alkali surfaces.
  9. Uncoated Steel and Iron Surfaces: Remove grease, mill scale, weld splatter, dirt, and rust. Where heavy coatings of scale are evident, remove by hand/power tool wire brushing or sandblasting; clean by washing with solvent. Apply a treatment of phosphoric acid solution, ensuring weld joints, bolts, and nuts are similarly cleaned. Spot prime paint after repairs.
  10. Shop Primed Steel Surfaces: Sand and scrape to remove loose primer and rust. Feather edges to make touch-up patches inconspicuous. Clean surfaces with solvent. Prime bare steel surfaces. Verify compatibility of specified primer and paint with shop applied primer.
  11. Verify project existing conditions and extend of patching needed.
  12. Interior Wood:
    - a. Opaque Finish: Wipe off dust and grit prior to priming. Seal knots, pitch streaks, and sappy sections with sealer. Fill joints, cracks, and nail holes, joints and cracks with caulking compound after primer has dried; sand between coats. [Fill gouges and grooves.]
    - b. Transparent Finish: Wipe off dust and grit prior to sealing, seal knots, pitch streaks, and sappy sections with sealer. Fill nail holes and cracks after sealer has dried; sand lightly between coats. Fill gouges and grooves.
  13. Exterior Wood: Scrape off all existing loose paint. Sand existing bare wood and painted wood surfaces.
  14. Wood and Metal Doors Scheduled for Painting: Seal top and bottom edges with primer.
  15. Delete option if there are no existing painted surfaces.
  16. Previously Painted Surfaces: Verify compatibility of new paint with existing. Remove existing paint and/or prime surfaces per manufacturers written instructions and as necessary for full adhesion of new paint.

### 3.2 PREPARATION

- B. Environmental Requirements:
  1. Relative Humidity Requirements: Do not apply exterior coatings during rain or snow, or when the relative humidity exceeds 85%.
  2. Temperature:
    - a. General: Do not apply materials when surface and ambient temperatures are outside the temperature ranges required by the manufacturer.
    - b. Exterior Paints: 50 degrees F minimum during and for 48 hours after application; do not apply when temperature is over 85 degrees F, except in protected or shaded areas.
    - c. Interior Paints: 65 degrees F for minimum of 48 hours before, during and for 48 hours after application.
  3. Ventilation: Provide adequate ventilation of all interior spaces during application and curing of all painting products.
  4. Lighting Level: Provide minimum 80 foot candles measured at mid-height of room.

### 3.3 APPLICATION

- C. General: Install in conformance with referenced standards, manufacturer's written directions, as shown, and as specified in Paint Schedules at end of this Section.
- D. Performance:

1. General: Apply each coat to uniform finish, slightly darker than preceding coat unless otherwise approved. As a minimum, dry film thickness of each coat shall meet manufacturer's specification.
  2. Wood and Metal Surfaces: Sand lightly between coats to achieve required finish. Vacuum clean surfaces free of loose particles; use tack cloth just prior to applying next coat. Allow applied coat to dry before next coat is applied.
  3. Clear Finishes: Tint fillers to match wood; work fillers into the grain before set and wipe excess from surface.
- E. Finishing Mechanical and Electrical Equipment: Refer to Division 22 – PLUMBING, Division 23 – HEATING, VENTILATING AND AIR CONDITIONING and Division 26 - ELECTRICAL for schedule of color coding and identification banding of equipment, duct work, piping, and conduit. Paint shop-primed equipment. Remove unfinished louvers, grilles, covers, and access panels on mechanical and electrical components mounted in finished ceilings and paint separately. Prime and paint insulated and exposed wall mounted pipes, conduit, boxes, hangers, brackets, collars and supports, to match adjacent wall surfaces. Paint both sides and edges of plywood backboards for electrical and telephone equipment before installing equipment. Non-finished ceiling mounted exposed ducts, brackets, collars and conduits shall not be painted.

#### 3.4 CLEANING

- F. General: Upon completion, remove masking materials, reinstall electrical cover plates, hardware, light fixture trim, escutcheons, and fittings removed prior to finishing, and thoroughly clean all exposed surfaces per manufacturer's instructions. Keep premises free from accumulation of waste and debris. At completion of work remove surplus materials and debris.
- G. Touch-up: After detailed inspection of paint work, touch up or refinish abraded, stained or otherwise disfigured work, as required by the Architect.
- H. Cleaning: Remove containers, rags and debris from the site; observe special care in control or disposal of flammable materials.

## EXTERIOR SURFACES

SURFACE	PAINT TYPE	COATS	MANUFACTURER'S PAINT NUMBERS					
			DUNN-EDWARDS	KELLY-MOORE	FRAZEE	SHERWIN-WILLIAMS	GLIDDEN PROF.	PPG
Wood, Painted	Exterior Primer	1	EZPR00	255	-	B42W804 1	6001	72-1
	Acrylic	2	SSHL50	1250	124	A100 A82	2406	6-900XI
Wood, Transparent	Acrylic Stain Base	1	WPT-3 (Okon)	1285	Zar	A15T5	-	77-1460
	Urethane Alkyd Varnish	2	DEFTHANE Polyurethane					77-10
Concrete	Masonry Primer	1	ESPR00	247	266	A24W200	6001	4-603
	Acrylic	2	SSHL50	1250	124	A100 A82	2406	6-900XI
Concrete, Elastomeric	Masonry Sealer	1	ESPR00	247	266	A24W200	6001	4-603
	Elastomeric Coating	2	W 370	1128	216	A5-400	2260	4-110
Concrete Block	Block Filler	1	SBPR00	521	262	B25W25	3030	4-100
	Acrylic	2	SSHL50	1250	124	A100 A82	2406	6-900XI
Cement Plaster	Masonry Primer	1	ESPR00	[247]	[266]	A24W300	6001	4-603
	Acrylic	2	SSHL10	1240	203	A100-A6	2200	6-610XI
Cement Plaster, Elastomeric	Masonry Sealer	1	ESPR00	247	266	A24W830 0	6001	4-603
	Elastomeric Coating	2	W 370	1128	216	A5-400	2260	4-110
Steel, Unprimed	Red Oxide Primer	1	BRPR00-1-RO)	5725-120	-	B66W310	4020	90-712
	Acrylic	2	SSHL50	1250	124	A100-A8	2406	90-1210
Steel, Shop Primed; Existing Painted	Metal Primer	Touch-up	BRPR00	5725	561	B66W310	4020	90-712
	Acrylic	2	SSHL50	1250	124	A100-A8	2406	90-1210
Steel, Galvanized	Galvanized Iron Primer	1	Rustoleum Bulls Eye 123	5725-120	-	B66W310	4020	90-712
	Acrylic	2	SSHL50	1250	124	A110-A8	2406	90-1210
Aluminum, Mill Finish	Acrylic Metal Primer	1	UGPR00	5725	168	B66W310	4020	90-712
	Acrylic	2	SSHL50	1250	124	A100-A8	2406	90-1210
Gypsum Sheathing	Masonry Primer	1	ESPR00	247	266	A24W830 0	6001	4-603
	Acrylic Finish	2	SSHL10	1200	203	A100-A6	2200	6-610XI



INTERIOR SURFACES – 2016 CALGreen									
SURFACE	PAINT TYPE	COATS	MANUFACTURER'S PAINT NUMBERS						
			DUNN-EDWARDS	KELLY-MOORE/	FRAZEE	SHERWIN-WILLIAMS/	GLIDDEN PROF.	PPG	SAFE COAT
Wood, Transparent	Sanding Sealer	1	N/A	4883		B26V43/C M15	Wood Pride 1916V		
	Acrylic Urethane	2	Defthane Water Based Polyurethane	2094		A68V91	Wood Pride 1808	42786	Polyureseal BP
Wood, Stained	Stain Finish	1	Valspar Graintone	Varathane Wiping Stain	Zar Ultra-Mac	Minwax 250voc	Wood Pride 1700V	44500	DuroStain
	Sanding Sealer	1	N/A	Valspar NAS1820 Luster Lac Premium Hi Build Water		CM15 White			
	Spar Varnish	2	Defthane Water Based Polyurethane	McCloskey's Spar Heirloom Varnish		SW: Wood Classics A68		42786	AcriGlaze
Wood Stage Flooring	Flat Latex	2	-	550 Acry-Plex Dark Secrets	-	Tread-Plex B90	3018	-	-
Concrete or Concrete Block, Eggshell	Acrylic Block Filler	1	SBPR00	521		B25W25	3010	4-100	
	Acrylic Enamel	2	SWLL30	1610		B20-2600	1412	9-300	
Concrete or Concrete Block, Semi-Gloss	Acrylic Block Filler	1	SBPR00	521		B25W25	3010	4-100	
	Finish	2	SWLL50	1650		B31-2600	1415	9-500	
Steel, Unprimed	Red Oxide Primer	1	BRPR00(w hite) BRPR00-1-R) (red)	5725-120		B66W310	4020	90-712	
	Enamel	2	EVSH50	1650		B31-2600	1415	9-500	
Steel, Primed; Existing Painted	Red Oxide Primer	Touch-up	BRPR00(w hite) BRPR00-1-R) (red)	5725-120		B66W310	4020	90-712	
	Enamel	2	EVSH50	1650		B31-2600	1415	9-500	
Steel, Galvanized	Acrylic Galv. Primer	1	UGPR00	1725		B66W310	4020	90-712	
	Enamel	2	EVSH50	1650		B31-2600	1415	9-500	
Aluminum, Mill Finish	Acrylic Metal Primer	1	UGPR00	1725		B66W310	4020	90-712	
	Enamel	2	EVSH50	1650		B31-2600	1415	9-500	

Concrete Floors	Acrylic Floor Coating	3	Rustoleum Porch and Floor	1786 or 1789			3018		
Gypsum Board or Plaster, Eggshell	Vinyl Wall Sealer	1	VNPR00	971		B28W400	1000	9-900	
	Acrylic Enamel	2	SWLL30	1610		B20-2600	1411	9-300	
Gypsum Board or Plaster, Semi-Gloss	Vinyl Wall Sealer	1	VNPR00	973		B28W400	1000	9-900	
	Enamel	2	SWLL50	1650		B31-2600	1415	9-500	
Gypsum Board or Tack Board, Vinyl Wall Covering	Acrylic Primer	1	UGPR00	973		B51	3210	17-921	
Canvas and Cotton Fabric	Acrylic Primer	1	UGPR00	973		B51	3210	17-921	
	Enamel	2	EVSH50	1650		B31-2600	1415	9-500	

END SECTION 09 90 00

## **SECTION 10 14 23 - SIGNAGE**

### **PART 1 - GENERAL**

#### **1.1 SUMMARY**

A. Section Includes:

1. Panel signs.
2. Vinyl Film

#### **1.2 ACTION SUBMITTALS**

A. Product Data: For each type of product.

B. Shop Drawings: For panel signs.

1. Include fabrication and installation details and attachments to other work.
2. Show sign mounting heights, locations of supplementary supports to be provided by other installers, and accessories.
3. Show message list, type styles, graphic elements, including raised characters and Braille, and layout for each sign.

C. Samples: For each exposed product and for each color and texture specified.

#### **1.3 INFORMATIONAL SUBMITTALS**

A. Sample warranty.

#### **1.4 CLOSEOUT SUBMITTALS**

A. Maintenance data.

#### **1.5 WARRANTY**

A. Warranty: Manufacturer agrees to repair or replace components of signs that fail in materials or workmanship within specified warranty period.

1. Warranty Period: Five years from date of Substantial Completion.
2. See Section 01 77 00 CLOSEOUT PROCEDURES for warranty information.

### **PART 2 - PRODUCTS**

#### **2.1 PERFORMANCE REQUIREMENTS**

A. Structural Performance: Signs and supporting elements shall withstand the effects of gravity and other loads within limits and under conditions indicated.

B. Design Requirements: Room Identification Signs (S-RI), Maximum Occupant Load signs (S-RC), Toilet Room Signs (S-TRW, S-TRD), Assistive Listening System Signs (S-ALD), Exit Signs (S-TE), and Miscellaneous Signs, as required by ADA and CBC.

1. General: Comply with Section 11B-703 for design and construction.
2. Raised Characters: Section 11B-703.2.

3. Braille Symbols: California Braille Grade 2, per Section 11B-703.3
4. Mounting Location and Height (where permanent identification is provided or where signage is required for rooms and spaces): Section 11B-703.4.
5. Visual Characters: Section 11B-703.5.
6. Pictograms: Section 11B-703.6.
7. Symbols of Accessibility: Section 11B-703.7.2.
8. Doorways leading to Men's and Women's Sanitary Facilities: Provide signs that comply with applicable requirements of Sections 11B-703.7.2.6..

## 2.2 PANEL SIGNS

- A. Panel Sign: Sign with smooth, uniform surfaces; with message and characters having uniform faces, sharp corners, and precisely formed lines and profiles:
1. Solid-Sheet Sign Acrylic sheet with finish specified in "Surface Finish and Applied Graphics" Subparagraph and as follows:
    - a. Inset, Cutout Characters: Sign face routed to receive push-through acrylic graphics slightly projecting from the sign panel.
  2. Sign-Panel Perimeter: Finish edges smooth.
    - a. Edge Condition Square cut.
    - b. Corner Condition in Elevation: As indicated on Drawings.
  3. Mounting: Surface mounted to wall with countersunk flathead through fasteners.
  4. Surface Finish and Applied Graphics:
    - a. Graphics: Manufacturer's standard, factory- acrylic polyurethane, in color as selected by Architect from manufacturer's full range.

## 2.3 SIGN MATERIALS

- A. Vinyl Film: UV-resistant vinyl film of nominal thickness indicated, with pressure-sensitive, permanent adhesive on back; die cut to form characters or images as indicated on Drawings and suitable for exterior applications.

## 2.4 ACCESSORIES

- A. Fasteners and Anchors: Manufacturer's standard as required for secure anchorage of signs, noncorrosive and compatible with each material joined, and complying with the following unless otherwise indicated:
1. Sign Mounting Fasteners:
    - a. Through Fasteners: Exposed metal fasteners matching sign finish, with type of head indicated, and installed in predrilled holes.
- B. Adhesive: As recommended by sign manufacturer.

- C. Two-Face Tape: Manufacturer's standard high-bond, foam-core tape, 0.045 inch thick, with adhesive on both sides.

### PART 3 - EXECUTION

#### 3.1 INSTALLATION

- A. General: Install signs using mounting methods indicated and according to manufacturer's written instructions.
  - 1. Install signs level, plumb, true to line, and at locations and heights indicated, with sign surfaces free of distortion and other defects in appearance.
  - 2. Install signs so they do not protrude or obstruct according to the accessibility standard.
  - 3. Before installation, verify that sign surfaces are clean and free of materials or debris that would impair installation.
- B. Mounting Methods:
  - 1. Through Fasteners: Drill holes in substrate using predrilled holes in sign as template. Countersink holes in sign if required. Place sign in position and flush to surface. Install through fasteners and tighten.
- C. Remove temporary protective coverings and strippable films as signs are installed.

**END OF SECTION 10 14 23**

## **SECTION 10 21 13 - PLASTIC TOILET COMPARTMENTS**

### **PART 1 - GENERAL**

#### **1.1 RELATED DOCUMENTS**

- A. Drawings and general provisions of the Contract, including General and Supplementary Conditions and Division 01 Specification Sections, apply to this Section.

#### **1.2 SUMMARY**

- A. Section Includes:

- 1. Solid-plastic toilet compartments configured as toilet enclosures.

- B. Related Requirements:

- 1. Section 06 10 00 "Rough Carpentry for blocking and overhead support of post-to-ceiling screens.
- 2. Section 10 28 00 "Toilet, Bath, and Laundry Accessories" for toilet tissue dispensers, grab bars, purse shelves, and similar accessories mounted on toilet compartments.

#### **1.3 ACTION SUBMITTALS**

- A. Product Data: For each type of product.

- 1. Include construction details, material descriptions, dimensions of individual components and profiles, and finishes for toilet compartments.

- B. Shop Drawings: For toilet compartments.

- 1. Include plans, elevations, sections, details, and attachment details.
- 2. Show locations of cutouts for compartment-mounted toilet accessories.
- 3. Show locations of centerlines of toilet fixtures.
- 4. Show locations of floor drains.
- 5. Show overhead support or bracing locations.

- C. Samples for Verification: For the following products, in manufacturer's standard sizes unless otherwise indicated:

- 1. Each type of material, color, and finish required for toilet compartments, prepared on 6-inch-square Samples of same thickness and material indicated for Work.
- 2. Each type of hardware and accessory.

#### **1.4 INFORMATIONAL SUBMITTALS**

- A. Product Certificates: For each type of toilet compartment.

#### **1.5 CLOSEOUT SUBMITTALS**

- A. Maintenance Data: For toilet compartments to include in maintenance manuals.

- B. Warranty Data: Per Section 01 77 00 CLOSEOUT PROCEDURES.

## 1.6 MAINTENANCE MATERIAL SUBMITTALS

- A. Furnish extra materials that match products installed and that are packaged with protective covering for storage and identified with labels describing contents and source.
  - 1. Door Hinges: One hinge(s) with associated fasteners.
  - 2. Latch and Keeper: One latch and keeper with associated fasteners.
  - 3. Door Bumper: One bumper with associated fasteners.
  - 4. Door Pull: One door pull with associated fasteners.
  - 5. Fasteners: Ten fasteners of each size and type.

## 1.7 PROJECT CONDITIONS

- A. Field Measurements: Verify actual locations of toilet fixtures, walls, columns, ceilings, and other construction contiguous with toilet compartments by field measurements before fabrication.

## PART 2 - PRODUCTS

### 2.1 PERFORMANCE REQUIREMENTS

- A. Surface-Burning Characteristics: Comply with ASTM E 84; testing by a qualified testing agency. Identify products with appropriate markings of applicable testing agency.
  - 1. Flame-Spread Index: 200 or less.
  - 2. Smoke-Developed Index: 450 or less.
- B. Regulatory Requirements: Comply with applicable provisions in the U.S. Architectural & Transportation Barriers Compliance Board's ADA-ABA Accessibility Guidelines for Buildings and Facilities and ICC A117.1 for toilet compartments designated as accessible.

### 2.2 SOLID-PLASTIC TOILET COMPARTMENTS

- A. Toilet-Enclosure Style: Overhead braced.
- B. Door, Panel and Pilaster Construction: Solid, high-density polyethylene (HDPE) panel material, not less than 1 inch thick, seamless, with eased edges, and with homogenous color and pattern throughout thickness of material.
  - 1. Color and Pattern: One color and pattern in each room as selected by Architect from manufacturer's full range.
- C. Pilaster Shoes and Sleeves (Caps): Manufacturer's standard design; stainless steel.
- D. Brackets (Fittings):
  - 1. Stirrup Type: Ear or U-brackets, stainless steel.

### 2.3 HARDWARE AND ACCESSORIES

- A. Hardware and Accessories: Manufacturer's standard operating hardware and accessories.
  - 1. Material: Stainless steel.
  - 2. Hinges: Manufacturer's standard paired, self-closing type that can be adjusted to hold doors open at any angle up to 90 degrees, allowing emergency access by lifting door.

3. Latch and Keeper: Manufacturer's standard surface-mounted latch unit designed for emergency access and with combination rubber-faced door strike and keeper. Provide units that comply with regulatory requirements for accessibility at compartments designated as accessible.
  4. Coat Hook: Manufacturer's standard combination hook and rubber-tipped bumper, sized to prevent in-swinging door from hitting compartment-mounted accessories.
  5. Door Bumper: Manufacturer's standard rubber-tipped bumper at out-swinging doors.
  6. Door Pull: Manufacturer's standard unit at out-swinging doors that complies with regulatory requirements for accessibility. Provide units on both sides of doors at compartments designated as accessible.
- B. Hardware and Accessories: Manufacturer's heavy-duty operating hardware and accessories.
  - C. Overhead Bracing: Manufacturer's standard continuous, extruded-aluminum head rail with antigrip profile and in manufacturer's standard finish.
  - D. Anchorages and Fasteners: Manufacturer's standard exposed fasteners of stainless steel, finished to match the items they are securing, with theft-resistant-type heads. Provide sex-type bolts for through-bolt applications. For concealed anchors, use stainless-steel, hot-dip galvanized-steel, or other rust-resistant, protective-coated steel compatible with related materials.

## 2.4 MATERIALS

- A. Stainless-Steel Sheet: ASTM A 666, Type 304, stretcher-leveled standard of flatness.
- B. Stainless-Steel Castings: ASTM A 743/A 743M.

## 2.5 FABRICATION

- A. Fabrication, General: Fabricate toilet compartment components to sizes indicated. Coordinate requirements and provide cutouts for through-partition toilet accessories where required for attachment of toilet accessories.
- B. Overhead-Braced Units: Provide manufacturer's standard corrosion-resistant supports, leveling mechanism, and anchors at pilasters to suit floor conditions. Provide shoes at pilasters to conceal supports and leveling mechanism.
- C. Door Size and Swings: Unless otherwise indicated, provide 24-inch- wide, in-swinging doors for standard toilet compartments and 36-inch- wide, in-swinging or out-swinging doors with a minimum 32-inch- wide, clear opening for compartments designated as accessible.

## PART 3 - EXECUTION

### 3.1 EXAMINATION

- A. Examine areas and conditions, with Installer present, for compliance with requirements for fastening, support, alignment, operating clearances, and other conditions affecting performance of the Work.
  1. Confirm location and adequacy of blocking and supports required for installation.
- B. Proceed with installation only after unsatisfactory conditions have been corrected.



### 3.2 INSTALLATION

- A. General: Comply with manufacturer's written installation instructions. Install units rigid, straight, level, and plumb. Secure units in position with manufacturer's recommended anchoring devices.
  - 1. Maximum Clearances:
    - a. Pilasters and Panels: 1/2 inch.
    - b. Panels and Walls: 1 inch.
  - 2. Stirrup Brackets: Secure panels to walls and to pilasters with no fewer than three brackets attached at midpoint and near top and bottom of panel.
    - a. Locate wall brackets so holes for wall anchors occur in masonry or tile joints.
    - b. Align brackets at pilasters with brackets at walls.
  - 3. Full-Height (Continuous) Brackets: Secure panels to walls and to pilasters with full-height brackets.
    - a. Locate bracket fasteners so holes for wall anchors occur in masonry or tile joints.
    - b. Align brackets at pilasters with brackets at walls.
- B. Overhead-Braced Units: Secure pilasters to floor and level, plumb, and tighten. Set pilasters with anchors penetrating not less than 1-3/4 inches into structural floor unless otherwise indicated in manufacturer's written instructions. Secure continuous head rail to each pilaster with no fewer than two fasteners. Hang doors to align tops of doors with tops of panels, and adjust so tops of doors are parallel with overhead brace when doors are in closed position.

### 3.3 ADJUSTING

- A. Hardware Adjustment: Adjust and lubricate hardware according to hardware manufacturer's written instructions for proper operation. Set hinges on in-swinging doors to hold doors open approximately 30 degrees from closed position when unlatched. Set hinges on out-swinging doors to return doors to fully closed position.

**END OF SECTION 10 21 13.19**

W

## **SECTION 10 28 00 - TOILET, BATH, AND LAUNDRY ACCESSORIES**

### **PART 1 - GENERAL**

#### **1.1 SUMMARY**

- A. Section Includes:
  - 1. Public-use washroom accessories.
  - 2. Childcare accessories.
  - 3. Underlavatory guards.
  - 4. Custodial accessories.

#### **1.2 SUBMITTALS**

- A. Product Data: For each type of product indicated.
- B. Product Schedule: Indicating types, quantities, sizes, and installation locations by room of each accessory required.
  - 1. Identify locations using room designations indicated.
  - 2. Identify products using designations indicated.
- C. Maintenance data.
- D. Warranty: Sample of special warranty.

#### **1.3 QUALITY ASSURANCE**

- A. Electrical Components, Devices, and Accessories: Listed and labeled as defined in NFPA 70, by a qualified testing agency, and marked for intended location and application.

#### **1.4 WARRANTY**

- A. Special Mirror Warranty: Manufacturer's standard form in which manufacturer agrees to replace mirrors that develop visible silver spoilage defects and that fail in materials or workmanship within specified warranty period.
  - 1. Warranty Period: 15 years from date of Substantial Completion.

### **PART 2 - PRODUCTS**

#### **2.1 PUBLIC-USE WASHROOM ACCESSORIES**

- A. Manufacturers: Subject to compliance with requirements, provide products by one of the following:
  - 1. A & J Washroom Accessories, Inc.
  - 2. American Specialties, Inc. – Basis of Design
  - 3. Bobrick Washroom Equipment, Inc.
  - 4. Bradley Corporation.

B. Toilet Tissue (Roll) Dispenser:

1. Basis-of-Design Product: American Specialties, Inc.: model #0030.
2. Description: Roll-in-reserve dispenser with hinged front secured with tumbler lockset.
3. Mounting: Surface mounted.
4. Capacity: Designed for 4-1/2- or 5-inch- diameter tissue rolls.
5. Material and Finish: Stainless steel, No. 4 finish (satin) with theft resistant spindles.

C. Paper Towel (Folded) Dispenser:

1. Basis-of-Design Product: American Specialties, Inc.: model #0210.
2. Mounting: Semi-Recessed Mounted.
3. Minimum Capacity: 525 multifold.
4. Material and Finish: Stainless steel, No. 4 finish (satin).
5. Lockset: Tumbler type.
6. Hinges: Stainless steel piano hinge.

D. Grab Bar:

1. Basis-of-Design Product: American Specialties, Inc.: model #3200.
2. Mounting: Flanges with concealed fasteners.
3. Material: Stainless steel, 0.05 inch thick.
  - a. Finish: Smooth, No. 4 finish (satin).
4. Outside Diameter: 1-1/2 inches.
5. Configuration and Length: As indicated on Drawings.

E. Sanitary-Napkin Disposal Unit:

1. Basis-of-Design Product: American Specialties, Inc.: model #0852.
2. Mounting: Surface mounted.
3. Door or Cover: Self-closing, sloping disposal-opening cover with full length piano hinge.
4. Receptacle: Removable.
5. Material and Finish: Stainless steel, No. 4 finish (satin).

F. Seat-Cover Dispenser (at all water closets):

1. Basis-of-Design Product: American Specialties, Inc.: model #0477-SM.
2. Mounting: Surface mounted.
3. Minimum Capacity: 250 seat covers.
4. Exposed Material and Finish: Stainless steel, No. 4 finish (satin).

G. Mirror Unit (Frameless. all toilet rooms):

1. Tilted and adjustable tilting mirrors are for use by people with disabilities. Adjustable tilting mirrors are prone to vandalism. In lieu of tilted mirrors, standard flat mirrors can be mounted at heights to accommodate users in wheelchairs.
2. Frameless
3. Retain first subparagraph below if required.
4. Hangers: Produce rigid, tamper- and theft-resistant installation, using method indicated below.

- a. Wall bracket of galvanized steel, equipped with concealed locking devices requiring a special tool to remove.
- 5. Size: 24" x 36" x 5/8" at single user restrooms, 72" x 48" x 5/8" at multi-user restrooms.
- H. Coat Hooks (in every water closet stall in multi-accommodation restrooms and back of door at single accommodations restrooms)
  - 1. Basis-of-Design Product: American Specialties, Inc.: model #0714
  - 2. Mounting: Surface mounted w/ 2 stainless steel screws.
  - 3. Chrome plated brass with a black neoprene bumper.

## 2.2 CHILDCARE ACCESSORIES

- A. Diaper-Changing Station:
  - 1. Basis-of-Design Product: American Specialties, Inc.: model #9013.
  - 2. Description: Horizontal unit that opens by folding down from stored position and with child-protection strap.
    - a. Engineered to support a minimum of 250-lb static load when opened.
  - 3. Mounting: Recessed.
  - 4. Operation: Counterbalanced by damped gas spring mechanism.
  - 5. Material and Finish: Flange and cabinet shall be type 304 stainless steel.
  - 6. Paper Towel and Liner Dispenser: Built in.

## 2.3 UNDER LAVATORY GUARDS

- A. Under Lavatory Guard:
  - 1. Description: Insulating pipe covering for supply and drain piping assemblies that prevent direct contact with and burns from piping; allow service access without removing coverings.
  - 2. Material and Finish: Antimicrobial, molded plastic, white.

## 2.4 CUSTODIAL ACCESSORIES

- A. Mop and Broom Holder (near utility sinks):
  - 1. Basis-of-Design Product: Acorn KMH
  - 2. Description: Unit with shelf, hooks, holders, and rod suspended beneath shelf.
  - 3. Length: 36 inches.
  - 4. Hooks: Three.
  - 5. Mop/Broom Holders: Four, spring-loaded, rubber hat, cam type.
  - 6. Material and Finish: Stainless steel, No. 4 finish (satin).

## 2.5 FABRICATION

- A. Keys: Provide universal keys for internal access to accessories for servicing and resupplying. Provide minimum of six keys to Owner's representative.

## PART 3 - EXECUTION

### 3.1 INSTALLATION

- A. Install accessories according to manufacturers' written instructions, using fasteners appropriate to substrate indicated and recommended by unit manufacturer. Install units level, plumb, and firmly anchored in locations and at heights indicated.
- B. Grab Bars: Install to withstand a downward load of at least 250 lbf, when tested according to ASTM F 446.

**END OF SECTION 10 28 00**

## **SECTION 10 44 16 - FIRE EXTINGUISHERS**

### **PART 1 - GENERAL**

#### **1.1 SUMMARY**

- A. Section includes portable, hand-carried fire extinguishers.

#### **1.2 ACTION SUBMITTALS**

- A. Product Data: For each type of product.

#### **1.3 INFORMATIONAL SUBMITTALS**

- A. Warranty: Sample of special warranty.

#### **1.4 CLOSEOUT SUBMITTALS**

- A. Operation and maintenance data.

#### **1.5 COORDINATION**

- A. Coordinate type and capacity of fire extinguishers with fire-protection cabinets to ensure fit and function.

#### **1.6 WARRANTY**

- A. Special Warranty: Manufacturer's standard form in which manufacturer agrees to repair or replace fire extinguishers that fail in materials or workmanship within specified warranty period.

- 1. Warranty Period: Six years from date of Substantial Completion.

### **PART 2 - PRODUCTS**

#### **2.1 PERFORMANCE REQUIREMENTS**

- A. NFPA Compliance: Fabricate and label fire extinguishers to comply with NFPA 10, "Portable Fire Extinguishers."
- B. Fire Extinguishers: Listed and labeled for type, rating, and classification by an independent testing agency acceptable to authorities having jurisdiction.

#### **2.2 PORTABLE, HAND-CARRIED FIRE EXTINGUISHERS**

- A. Fire Extinguishers: Type, size, and capacity for each fire-protection cabinet indicated.
  - a. Amerex Corporation.
  - b. JL Industries.
  - c. Kidde Residential and Commercial Division; Subsidiary of Kidde plc.
  - d. Larsen's Manufacturing Company.
  - e. Potter Roemer LLC.
  - f. Pyro-Chem; Tyco Safety Products.

2. Instruction Labels: Include pictorial marking system complying with NFPA 10, Appendix B.
- B. Multipurpose Dry-Chemical Type: UL-rated 10 lbs nominal capacity, with monoammonium phosphate-based dry chemical in manufacturer's standard enameled container.

### PART 3 - EXECUTION

#### 3.1 INSTALLATION

- A. Examine fire extinguishers for proper charging and tagging.
  1. Remove and replace damaged, defective, or undercharged fire extinguishers.
- B. Install fire extinguishers in locations indicated and in compliance with requirements of authorities having jurisdiction.

**END OF SECTION 10 44 16**

## **SECTION 12 32 16 - MANUFACTURED PLASTIC-LAMINATE-FACED CASEWORK**

### **PART 1 - GENERAL**

#### **1.1 RELATED DOCUMENTS**

- A. Drawings and general provisions of the Contract, including General and Supplementary Conditions and Division 01 Specification Sections, apply to this Section.

#### **1.2 SUMMARY**

- A. Section includes plastic-laminate-faced cabinets of stock design.
- B. Related Requirements:
  - 1. Section 06 10 00 "Rough Carpentry for wood blocking for anchoring casework.
  - 2. Section 09 65 13 "Resilient Base and Accessories" for resilient base applied to plastic-laminate-faced casework.
  - 3. Section 12 36 23. "Plastic-Laminate-Clad Countertops."
  - 4. Section 12 36 61.16 "Solid Surfacing Countertops."

#### **1.3 DEFINITIONS**

- A. Definitions in the AWI's, AWMAC's, and WI's "Architectural Woodwork Standards" apply to the work of this Section.
- B. MDF: Medium-density fiberboard.
- C. Hardwood Plywood: A panel product composed of layers or plies of veneer, or of veneers in combination with lumber core, hardboard core, MDF core, or particleboard core, joined with adhesive, and faced both front and back with hardwood veneers.

#### **1.4 COORDINATION**

- A. Coordinate sizes and locations of framing, blocking, furring, reinforcements, and other related units of Work specified in other Sections to ensure that casework can be supported and installed as indicated.

#### **1.5 ACTION SUBMITTALS**

- A. Product Data: For each type of product.
- B. Sustainable Design Submittals:
- C. Shop Drawings: Include plans, elevations, sections, details, and attachments to other work. Show fabrication details, including types and locations of hardware. Show installation details, including field joints and filler panels. Indicate manufacturer's catalog numbers for casework.
- D. Keying Schedule: Include schematic keying diagram and index each key set to unique designations that are coordinated with the Contract Documents.
- E. Samples: For cabinet finishes.
- F. Samples for Verification: 8-by-10-inch Samples for each type of finish.



## 1.6 INFORMATIONAL SUBMITTALS

- A. Qualification Data: For Installer.
- B. Quality Standard Compliance Certificates: WI Certified Compliance Program certificates.
- C. Sample Warranty: For special warranty.

## 1.7 QUALITY ASSURANCE

- A. Installer Qualifications: An authorized representative who is trained and approved by manufacturer for installation of units required for this Project and who isa licensee of WI's Certified Compliance Program.

## 1.8 DELIVERY, STORAGE, AND HANDLING

- A. Deliver casework only after painting, utility roughing-in, and similar operations that could damage, soil, or deteriorate casework have been completed in installation areas. If casework must be stored in other than installation areas, store only in areas where environmental conditions meet requirements specified in "Project Conditions" Article.
- B. Keep finished surfaces covered with polyethylene film or other protective covering during handling and installation.

## 1.9 FIELD CONDITIONS

- A. Environmental Limitations: Do not deliver or install casework until building is enclosed, wet work is complete, and HVAC system is operating and maintaining temperature and relative humidity at occupancy levels during the remainder of the construction period. Maintain temperature and relative humidity during the remainder of the construction period in range recommended for Project location by the AWMAC's and WI's "Architectural Woodwork Standards."
- B. Established Dimensions: Where casework is indicated to fit to other construction, establish dimensions for areas where woodwork is to fit. Provide allowance for trimming at site, and coordinate construction to ensure that actual dimensions correspond to established dimensions.
- C. Locate concealed framing, blocking, and reinforcements that support casework by field measurements before being enclosed, and indicate measurements on Shop Drawings.

## 1.10 WARRANTY

- A. Special Warranty: Manufacturer agrees to repair or replace components of casework that fail in materials or workmanship within specified warranty period.
  - 1. Failures include, but are not limited to, the following:
    - a. Delamination of components or other failures of glue bond.
    - b. Warping of components.
    - c. Failure of operating hardware.
  - 2. Warranty Period: Five years from date of Substantial Completion.

## PART 2 - PRODUCTS

### 2.1 MANUFACTURERS

- A. Source Limitations: Obtain plastic-laminate-faced cabinets from single manufacturer.

### 2.2 CASEWORK, GENERAL

- A. Quality Standard: Unless otherwise indicated, comply with the AWMAC's and WI's "Architectural Woodwork Standards" for grades of casework indicated for construction, finishes, installation, and other requirements.
  - 1. Grade: Custom.
  - 2. Provide labels and certificates] from WI certification program indicating that casework including installation, complies with requirements of grades specified.
- B. Product Designations: Drawings indicate configurations of manufactured plastic-laminate-faced cabinets by referencing designations of Casework Design Series numbering system in Appendix A of the AWI's, AWMAC's, and WI's "Architectural Woodwork Standards."

### 2.3 CASEWORK

- A. Design:
  - 1. Flush overlay.
- B. Grain Direction for Wood Grain Plastic Laminate:
  - 1. Vertical on both doors and drawer fronts, with continuous vertical matching.
  - 2. Lengthwise on face frame members.
  - 3. Vertical on end panels.
  - 4. Side to side on bottoms and tops of units.
  - 5. Vertical on knee-space panels.
  - 6. Horizontal on aprons.
- C. Exposed Materials:
  - 1. Plastic Laminate: Grade VGS.
    - a. Colors and Patterns: As noted on Drawings.
  - 2. Unless otherwise indicated, provide specified edge banding on all exposed edges.
  - 3. Plywood: As noted on Drawings.
- D. Semi-exposed Materials:
  - 1. Plastic Laminate: Grade VGS unless otherwise indicated. Provide plastic laminate for semi-exposed surfaces unless otherwise indicated.
    - a. Provide plastic laminate of same grade as exposed surfaces for interior faces of doors and drawer fronts and other locations where opposite side of component is exposed.
  - 2. Thermoset Decorative Panels: Provide thermoset decorative panels for semi-exposed surfaces unless otherwise indicated.

- a. Provide plastic laminate of same grade as exposed surfaces for interior faces of doors and drawer fronts and other locations where opposite side of component is exposed.
  - 3. Hardboard: Use only for cabinet backs where exterior side of back is not exposed.
  - 4. Unless otherwise indicated, provide specified edge banding on all semi-exposed edges.
- E. Concealed Materials:
- 1. Solid Wood: Any hardwood or softwood species, with no defects affecting strength or utility.
  - 2. Plywood: Hardwood plywood.
  - 3. Plastic Laminate: Grade BKL.
  - 4. Particleboard.
  - 5. MDF.
  - 6. Hardboard.

## 2.4 MATERIALS

- A. Maximum Moisture Content for Lumber: 7 percent for hardwood and 12 percent for softwood.
- B. Hardwood Plywood: HPVA HP-1, particleboard core except where veneer core is indicated.
- C. Softwood Plywood: DOC PS 1.
- D. Particleboard: ANSI A208.1, Grade M-2.
- E. Particleboard: Straw-based particleboard complying with ANSI A208.1, Grade M-2, except for density.
- F. MDF: ANSI A208.2, Grade 130.
- G. Hardboard: ANSI A135.4, Class 1 Tempered.
- H. Plastic Laminate: High-pressure decorative laminate complying with NEMA LD 3.
- I. Edge banding for Plastic Laminate: Rigid PVC extrusions, through color with satin finish, 3 mm thick at doors and drawer fronts, 1 mm thick elsewhere.
- J. Thermoset Decorative Panels: Particleboard or medium-density fiberboard finished with thermally fused, melamine-impregnated decorative paper and complying with requirements of NEMA LD 3, Grade VGL, for Test Methods 3.3, 3.4, 3.6, 3.8, and 3.10.
- K. Edge banding for Thermoset Decorative Panels: PVC or polyester edge banding matching thermoset decorative panels.

## 2.5 COLORS AND FINISHES

- A. Wood Colors and Finishes: As noted on Drawings.
- B. Plastic-Laminate Colors, Patterns, and Finishes: As noted on Drawings.
- C. PVC Edge banding Color: As selected from casework manufacturer's full range.

## 2.6 FABRICATION

- A. Plastic-Laminate-Faced Cabinet Construction: As required by referenced quality standard, but not less than the following:
1. Bottoms and Ends of Cabinets, and Tops of Wall Cabinets and Tall Cabinets: 3/4-inch particleboard.
  2. Shelves: 3/4-inch- thick particleboard for shelves up to 36-inch wide, 3/4-inch- thick plywood or 1-inch- thick particleboard for shelves over 36-wide.
  3. Backs of Cabinets: 1/2-inch- thick particleboard or MDF where exposed, 1/4-inch hardboard dadoed into sides, bottoms, and tops where not exposed.
  4. Drawer Fronts: 3/4-inch particleboard.
  5. Drawer Sides and Backs: 1/2-inch solid-wood or veneer-core hardwood plywood, with glued dovetail or multiple-dowel joints.
  6. Drawer Bottoms: 1/4-inch [hardwood plywood] [particleboard or MDF] glued and dadoed into front, back, and sides of drawers. Use 1/2-inch material for drawers more than 24 inches wide.
  7. Doors 48 Inches High or Less: 3/4 inch thick, with particleboard or MDF cores.
- B. Filler Strips: Provide as needed to close spaces between cabinets and walls, ceilings, and indicated equipment. Fabricate from same material and with same finish as cabinets.

## 2.7 CASEWORK HARDWARE AND ACCESSORIES

- A. Hardware, General: Unless otherwise indicated, provide manufacturer's standard satin-finish, commercial-quality, heavy-duty hardware.
1. Use threaded metal or plastic inserts with machine screws for fastening to particleboard except where hardware is through-bolted from back side.
- B. Butt Hinges: Stainless-steel, semi-concealed, five-knuckle hinges complying with BHMA A156.9, Grade 1, with antifriction bearings and rounded tips. Provide two hinges for doors less than 48 inches high.
- C. Pulls: Solid stainless-steel wire pulls, fastened from back with two screws. Provide two pulls for drawers more than 24 inches wide.
- D. Pulls: Semi-recessed plastic pulls. For sliding doors, provide recessed plastic flush-pulls. Provide two pulls for drawers more than 24 inches wide.
- E. Door Catches: Dual, self-aligning, permanent magnet catch. Provide two catches on doors more than 48 inches high.
- F. Drawer Slides: BHMA A156.9, Type B05091.
1. Heavy Duty (Grade 1HD-100 and Grade 1HD-200): Side mounted; full-extension type; zinc-plated, steel ball-bearing slides.
- G. Drawer and Hinged Door Locks: Cylindrical (cam) type, five-pin tumbler, brass with chrome-plated finish, and complying with BHMA A156.11, Grade 1.
1. Provide a minimum of two keys per lock and six master keys.
  2. Provide on all doors and drawers.
- H. Adjustable Shelf Supports: Single-pin metal shelf rests complying with BHMA A156.9, Type B04013.

## PART 3 - EXECUTION

### 3.1 EXAMINATION

- A. Examine areas, with Installer present, for compliance with requirements for installation tolerances, location of framing and reinforcements, and other conditions affecting performance of the Work.
- B. Proceed with installation only after unsatisfactory conditions have been corrected.

### 3.2 CASEWORK INSTALLATION

- A. Grade: Install cabinets to comply with same grade as item to be installed.
- B. Install casework level, plumb, and true; shim as required, using concealed shims. Where casework abuts other finished work, apply filler strips and scribe for accurate fit, with fasteners concealed where practical.
- C. Base Cabinets: Set cabinets straight, level, and plumb. Adjust sub-tops within 1/16 inch of a single plane. Align similar adjoining doors and drawers to a tolerance of 1/16 inch. Bolt adjacent cabinets together with joints flush, tight, and uniform.
- D. Wall Cabinets: Hang cabinets straight, level, and plumb. Adjust fronts and bottoms within 1/16 inch of a single plane. Fasten to hanging strips, masonry, framing, wood blocking, or reinforcements in walls and partitions. Align similar adjoining doors to a tolerance of 1/16 inch.
- E. Fasten cabinets to adjacent cabinets and to masonry, framing, wood blocking, or reinforcements in walls and partitions to comply with the AWMAC's and WI's "Architectural Woodwork Standards."
- F. Install hardware uniformly and precisely. Set hinges snug and flat in mortises unless otherwise indicated. Adjust and align hardware so moving parts operate freely and contact points meet accurately. Allow for final adjustment after installation.
- G. Adjust casework and hardware so doors and drawers operate smoothly without warp or bind. Lubricate operating hardware as recommended by manufacturer.

### 3.3 CLEANING

- A. Repair or remove and replace defective work as directed on completion of installation.
- B. Clean finished surfaces, touch up as required, and remove or refinish damaged or soiled areas to match original factory finish, as approved by Architect.

**END OF SECTION 12 32 16**

## SECTION 12 36 23.13 - PLASTIC-LAMINATE-CLAD COUNTERTOPS

### PART 1 - GENERAL

#### 1.1 RELATED DOCUMENTS

- A. Drawings and general provisions of the Contract, including General and Supplementary Conditions and Division 01 Specification Sections, apply to this Section.
- B. Section 12 32 16 Manufactured Plastic-Laminate-Faced Casework.

#### 1.2 SUMMARY

- A. Section includes plastic-laminate-clad countertops.

#### 1.3 ACTION SUBMITTALS

- A. Product Data: For each type of product.
  - 1. Include data for fire-retardant treatment from chemical-treatment manufacturer and certification by treating plant that treated materials comply with requirements.
- B. Shop Drawings: For plastic-laminate-clad countertops.
  - 1. Include plans, sections, details, and attachments to other work. Detail fabrication and installation, including field joints.
  - 2. Show locations and sizes of cutouts and holes for items installed in plastic-laminate-clad countertops.
  - 3. Apply **WI Certified Compliance** Program label to Shop Drawings.
- C. Samples: Plastic laminates in each type, color, pattern, and surface finish required in manufacturer's standard size.

#### 1.4 INFORMATIONAL SUBMITTALS

- A. Qualification Data: For Installer and fabricator.
- B. Product Certificates: For the following:
  - 1. Composite wood and agrifiber products.
  - 2. High-pressure decorative laminate.
  - 3. Chemical-resistant, high-pressure decorative laminate.
  - 4. Adhesives.
- C. Quality Standard Compliance Certificates: **WI Certified Compliance Program**.
- D. Evaluation Reports: For fire-retardant-treated materials, from ICC-ES.

#### 1.5 QUALITY ASSURANCE

- A. Fabricator Qualifications: Shop that employs skilled workers who custom fabricate products similar to those required for this Project and whose products have a record of successful in-service performance.
  - 1. Shop Certification: WI's Certified Compliance Program licensee.

- B. Installer Qualifications WI's Certified Compliance Program licensee.

#### 1.6 DELIVERY, STORAGE, AND HANDLING

- A. Deliver countertops only after casework and supports on which they will be installed have been completed in installation areas.
- B. Store countertops in areas where environmental conditions comply with requirements specified in "Field Conditions" Article.
- C. Keep surfaces of countertops covered with protective covering during handling and installation.

#### 1.7 FIELD CONDITIONS

- A. Environmental Limitations: Do not deliver or install countertops until building is enclosed, wet-work is complete, and HVAC system is operating and maintaining temperature and relative humidity at levels planned for building occupants during the remainder of the construction period.
- B. Field Measurements: Where countertops are indicated to fit to other construction, verify dimensions of other construction by field measurements before fabrication and indicate measurements on Shop Drawings. Coordinate fabrication schedule with construction progress to avoid delaying the Work.

### PART 2 - PRODUCTS

#### 2.1 PLASTIC-LAMINATE-CLAD COUNTERTOPS

- A. Quality Standard: Unless otherwise indicated, comply with the "Architectural Woodwork Standards" for grades of plastic-laminate-clad countertops indicated for construction, finishes, installation, and other requirements.
  - 1. Provide inspections of fabrication and installation together with labels and certificates from WI certification program indicating that countertops comply with requirements of grades specified.
- B. Grade: **Custom**.
- C. High-Pressure Decorative Laminate: NEMA LD 3, **Grade HGS**.
- D. Colors, Patterns, and Finishes: Provide materials and products that result in colors and textures of exposed laminate surfaces complying with the following requirements:
  - 1. As indicated on Drawings.
- E. Edge Treatment: 3-mm PVC edging.
- F. Core Material: As selected by fabricator to comply with quality standard.
- G. Core Thickness: 3/4 inch
  - 1. Build up countertop thickness to 1-1/2 inches at front, back, and ends with additional layers of core material laminated to top.

## 2.2 WOOD MATERIALS

- A. Wood Products: Provide materials that comply with requirements of referenced quality standard unless otherwise indicated.
- B. Composite Wood and Agrifiber Products: Provide materials that comply with requirements of referenced quality standard for each type of countertop and quality grade specified unless otherwise indicated.
  - 1. MDF: Medium-density fiberboard, ANSI A208.2, Grade 130.
  - 2. Particleboard: ANSI A208.1, Grade M-2.
  - 3. Softwood Plywood: DOC PS 1.

## 2.3 ACCESSORIES

- A. Wire-Management Grommets: Circular, molded-plastic grommets and matching plastic caps with slot for wire passage.
  - 1. Outside Diameter: 1-1/4 inch
  - 2. Color: As selected by Architect from full range of colors to coordinated with countertop.

## 2.4 MISCELLANEOUS MATERIALS

- A. Adhesive for Bonding Plastic Laminate: As selected by fabricator to comply with requirements.

## 2.5 FABRICATION

- A. Fabricate countertops to dimensions, profiles, and details indicated. Provide front and end overhang of 1 inch over base cabinets. Ease edges to radius indicated for the following:
  - 1. Solid-Wood (Lumber) Members: 1/16 inch unless otherwise indicated.
- B. Complete fabrication, including assembly, to maximum extent possible before shipment to Project site. Disassemble components only as necessary for shipment and installation. Where necessary for fitting at site, provide ample allowance for scribing, trimming, and fitting.
- C. Shop cut openings to maximum extent possible to receive appliances, plumbing fixtures, electrical work, and similar items. Locate openings accurately, and use templates or roughing-in diagrams to produce accurately sized and shaped openings. Sand edges of cutouts to remove splinters and burrs.
  - 1. Seal edges of cutouts by saturating with varnish.

## PART 3 - EXECUTION

### 3.1 PREPARATION

- A. Before installation, condition countertops to average prevailing humidity conditions in installation areas.
- B. Before installing countertops, examine shop-fabricated work for completion and complete work as required, including removal of packing.



### 3.2 INSTALLATION

- A. Grade: Install countertops to comply with same grade as item to be installed.
- B. Assemble countertops and complete fabrication at Project site to the extent that it was not completed in the shop.
- C. Field Jointing: Where possible, make in the same manner as shop jointing, using dowels, splines, adhesives, and fasteners recommended by manufacturer. Prepare edges to be joined in shop so Project-site processing of top and edge surfaces is not required. Locate field joints where shown on Shop Drawings.
  - 1. Secure field joints in countertops with concealed clamping devices located within 6 inches of front and back edges and at intervals not exceeding 24 inches. Tighten according to manufacturer's written instructions to exert a constant, heavy-clamping pressure at joints.
- D. Scribe and cut countertops to fit adjoining work, refinish cut surfaces, and repair damaged finish at cuts.
- E. Countertop Installation: Anchor securely by screwing through corner blocks of base cabinets or other supports into underside of countertop.
  - 1. Install countertops level and true in line. Use concealed shims as required to maintain not more than a 1/8-inch-in-96-inches variation from a straight, level plane.

### 3.3 ADJUSTING AND CLEANING

- A. Repair damaged and defective countertops, where possible, to eliminate functional and visual defects. Where not possible to repair, replace countertops. Adjust joinery for uniform appearance.
- B. Clean countertops on exposed and semi-exposed surfaces.
- C. Protection: Provide Kraft paper or other suitable covering over countertop surfaces, taped to underside of countertop at a minimum of 48 inches o.c. Remove protection at Substantial Completion.

**END OF SECTION 12 36 23.13**

## **SECTION 12 36 61.16 - SOLID SURFACING COUNTERTOPS**

### **PART 1 - GENERAL**

#### **1.1 RELATED DOCUMENTS**

- A. Drawings and general provisions of the Contract, including General and Supplementary Conditions and Division 01 Specification Sections, apply to this Section.

#### **1.2 SUMMARY**

##### **A. Section Includes:**

1. Solid surface material countertops.
2. Solid surface material backsplashes.
3. Solid surface material end splashes.
4. Solid surface material apron fronts.

##### **B. Related Requirements:**

1. Section 22 40 00 "Plumbing Fixtures" for non-integral sinks and plumbing fittings.

#### **1.3 ACTION SUBMITTALS**

##### **A. Product Data:** For countertop materials.

##### **B. Shop Drawings:** For countertops. Show materials, finishes, edge and backsplash profiles, methods of joining, and cutouts for plumbing fixtures.

1. Show locations and details of joints.
2. Show direction of directional pattern, if any.

##### **C. Samples for Verification:** For the following products:

1. Countertop material, 6 inches square.

#### **1.4 INFORMATIONAL SUBMITTALS**

##### **A. Qualification Data:** For fabricator.

#### **1.5 CLOSEOUT SUBMITTALS**

##### **A. Maintenance Data:** For solid surface material countertops to include in maintenance manuals. Include Product Data for care products used or recommended by Installer and names, addresses, and telephone numbers of local sources for products.

##### **B. Provide Warranty information as noted in Section 01 77 00 CLOSEOUT PROCEDURES.**

#### **1.6 QUALITY ASSURANCE**

##### **A. Fabricator Qualifications:** Shop that employs skilled workers who custom-fabricate countertops similar to that required for this Project, and whose products have a record of successful in-service performance.

##### **B. Installer Qualifications:** Fabricator of countertops.

1.7 FIELD CONDITIONS

- A. Field Measurements: Verify dimensions of countertops by field measurements after base cabinets are installed but before countertop fabrication is complete.

1.8 COORDINATION

- A. Coordinate locations of utilities that will penetrate countertops or backsplashes.

PART 2 - PRODUCTS

2.1 SOLID SURFACE COUNTERTOP MATERIALS

- A. Solid Surface Material: Homogeneous-filled plastic resin complying with ICPA SS-1.
  - 1. Type: Provide Standard type] unless Special Purpose type is indicated.
  - 2. Colors and Patterns: As indicated on Drawings.

2.2 COUNTERTOP FABRICATION

- A. Fabricate countertops according to solid surface material manufacturer's written instructions and to the AWI/AWMAC/WI's "Architectural Woodwork Standards."
  - 1. Grade: Custom.
  - 2. Front Straight, slightly eased at top with separate apron, 6 inches high, recessed 1/4-inch behind front edge.
  - 3. Backsplash: Straight, slightly eased at corner.
- B. End Splash: Matching backsplash. Countertops: 1/2-inch- thick, solid surface material.
- C. Backsplashes: 1/2-inch-thick, solid surface material.
- D. Fabricate tops with shop-applied edges [and backsplashes] unless otherwise indicated. Comply with solid surface material manufacturer's written instructions for adhesives, sealers, fabrication, and finishing.
- E. Joints: Fabricate countertops without joints.
- F. Cutouts and Holes:
  - 1. Counter-Mounted Plumbing Fixtures: Prepare countertops in shop for field cutting openings for counter-mounted fixtures. Mark tops for cutouts and drill holes at corners of cutout locations. Make corner holes of largest radius practical.
  - 2. Fittings: Drill countertops in shop for plumbing fittings, under-counter soap dispensers, and similar items.

2.3 INSTALLATION MATERIALS

- A. Adhesive: Product recommended by solid surface material manufacturer.
- B. Sealant for Countertops: Comply with applicable requirements in Section 07 92 00 "Joint Sealants."

PART 3 - EXECUTION

3.1 EXAMINATION

- A. Examine substrates to receive solid surface material countertops and conditions under which countertops will be installed, with Installer present, for compliance with requirements for installation tolerances and other conditions affecting performance of countertops.
- B. Proceed with installation only after unsatisfactory conditions have been corrected.

3.2 INSTALLATION

- A. Install countertops level to a tolerance of 1/8 inch in 8 feet, 1/4 inch maximum. Do not exceed 1/64-inch difference between planes of adjacent units.
- B. Install backsplashes and end splashes by adhering to wall and countertops with adhesive. Mask areas of countertops and splashes adjacent to joints to prevent adhesive smears.
- C. Install aprons to backing and countertops with adhesive. Mask areas of countertops and splashes adjacent to joints to prevent adhesive smears. Fasten by screwing through backing. Pre-drill holes for screws as recommended by manufacturer.
- D. Complete cutouts not finished in shop. Mask areas of countertops adjacent to cutouts to prevent damage while cutting. Make cutouts to accurately fit items to be installed, and at right angles to finished surfaces unless beveling is required for clearance. Ease edges slightly to prevent snipping.
- E. Apply sealant to gaps at walls; comply with Section 07 92 00 "Joint Sealants."

**END OF SECTION 12 36 61.16**

## SECTION 22 00 50 - BASIC PLUMBING MATERIALS AND METHODS

### PART 1 - GENERAL

#### 1.1 SUMMARY

A. Section Includes:

1. Electric motors.
2. Motor starters.
3. Valves and fittings.
4. Gauges.
5. Thermometers.
6. Access Doors.
7. Insulation.

#### 1.2 RELATED REQUIREMENTS

- A. Drawings and general provisions of the Contract, including General and Supplementary Conditions and Division 01 Specification Sections, apply to this Section.
- B. This Section is a part of each Division 22 Section.

#### 1.3 ADDITIONAL REQUIREMENTS

- A. Furnish and install any incidental work not shown or specified which is necessary to provide a complete and workable system.
- B. Make all temporary connections required to maintain services during the course of this Contract without additional cost to the Owner. Notify the Owner seven days in advance before disturbing any service.
- C. All plumbing work required by Contract Documents shall be performed in strict accordance with all codes and regulations. Plumbing work done under this contract shall not adversely affect the operation of the existing plumbing systems.

#### 1.4 REFERENCES AND STANDARDS

- A. Where material or equipment is specified to conform to referenced standards, it shall be assumed that the most recent edition of the standard in effect at the time of bid shall be used.
1. CSA – Canadian Standards Association International.
  2. ANSI - American National Standards Institute.
  3. ASTM - American Society for Testing and Materials.
  4. CCR - California Code of Regulations.
    - a. Title 8 - Division of Industrial Safety, Subchapter 7; General Industry Safety Orders, Articles 31 through 36.
  5. NCPWB - National Certified Pipe Welding Bureau.
  6. CEC - California Electrical Code.
  7. NEMA - National Electrical Manufacturers' Association.
  8. NFPA - National Fire Protection Association.
  9. OSHA - Occupational Safety and Health Act.

10. UL - Underwriters' Laboratories, Inc.

B. Requirements of Regulatory Agencies:

1. The publications listed below form part of this specification; comply with provisions of these publications except as otherwise shown or specified.

- a. California Building Code, 2016.
- b. California Electrical Code, 2016.
- c. California Energy Code, 2016.
- d. California Fire Code, 2016.
- e. California Green Building Standards Code, 2016.
- f. California Mechanical Code, 2016.
- g. California Plumbing Code, 2016.
- h. California Code of Regulations, Title 24.
- i. California Health and Safety Code.
- j. CAL-OSHA.
- k. California State Fire Marshal, Title 19 CCR.
- l. National Fire Protection Association.
- m. Occupational Safety and Health Administration.
- n. Other applicable state laws.

2. Nothing in Drawings or specifications shall be construed to permit work not conforming to these codes, or to requirements of authorities having jurisdiction. It is not the intent of Drawings or specifications to repeat requirements of codes except where necessary for clarity.

1.5 DRAWINGS

A. Examine Contract Documents prior to bidding of work and report discrepancies in writing to Architect.

B. Drawings showing location of equipment and materials are diagrammatic and job conditions will not always permit installation in location shown. The Plumbing Drawings show general arrangement of equipment and materials, etc., and shall be followed as closely as existing conditions, actual building construction, and work of other trades permit.

1. Architectural and Structural Drawings shall be considered part of the Work. These Drawings furnish Contractor with information relating to design and construction of the Project. Architectural Drawings take precedence over Plumbing Drawings.
2. Because of the small scale of Plumbing Drawings, not all offsets, fittings, and accessories required are shown. Investigate structural and finish conditions affecting the Work and arrange Work accordingly. Provide offsets, fittings, and accessories required to meet conditions. Inform Architect immediately when job conditions do not permit installation of equipment and materials in the locations shown. Obtain the Architects approval prior to relocation of equipment and materials.
3. Relocate equipment and materials installed without prior approval of the Architect. Remove and relocate equipment and materials at Contactors' expense upon Architects' direction.
4. Minor changes in locations of equipment, piping, etc., from locations shown shall be made when directed by the Architect at no additional cost to the Owner providing such change is ordered before such items of work, or work directly connected to same are installed and providing no additional material is required.

- C. Execute work mentioned in Specifications and not shown on Drawings, or vice versa, the same as if specifically mentioned or shown in both.

#### 1.6 FEES AND PERMITS

- A. Obtain and coordinate payment by Owner for all permits and service required in installation of this work; arrange for required inspections and secure approvals from authorities having jurisdiction. Comply with requirements of Division 01.

- B. Coordination:

- 1. General:

- a. Coordinate plumbing Work with trades covered in other Specifications Sections to provide a complete, operable and sanitary installation of the highest quality workmanship.

- 2. Electrical Coordination:

- a. Refer to the Electrical Drawings and Specifications, Division 26, for service voltage and power feed wiring for equipment specified under this section. Contractor has full responsibility for the following items of work:

- 1) Review the Electrical Drawings and Division 26 Specifications to verify that electrical services provided are adequate and compatible with equipment requirements.
      - 2) If additional electrical services are required above that indicated on Electrical Drawings and in Division 26, such as more control interlock conductors, larger feeder, or separate 120 volt control power source, include cost to furnish and install additional electrical services as part of the bid.
      - 3) Prior to proceeding with installation of additional electrical work, submit detailed drawings indicating exact scope of additional electrical work.

- 3. Mechanical Coordination:

- a. Arrange for pipe spaces, chases, slots and openings in building structure during progress of construction, to accommodate mechanical system installation.
      - b. Coordinate installation of supporting devices. Set sleeves in poured-in-place concrete and other structural components during progress of construction.
      - c. Coordinate requirements for access panels and doors for mechanical items requiring access where concealed behind finished surfaces. Access panels and doors are specified in Division 08 Section "Access Doors and Frames."
      - d. Coordinate with other trades equipment locations, pipe, duct and conduit runs, electrical outlets and fixtures, air inlets and outlets, and structural and architectural features. Provide information on location of piping and seismic bracing to other trades as required for a completely coordinated project.

#### 1.7 SUBMITTALS - GENERAL

- A. Provide submittal of materials proposed for use as part of this Project. Product names in Specifications and on Drawings are used as standards of quality. Furnish standard items on specified equipment at no extra cost to the Contract regardless of disposition of submittal data. Other materials or methods shall not be used unless approved in writing by Architect. Architect's review will be required even though "or equal" or synonymous terms are used. Refer to Division 01 for complete instructions.

1. Partial or incomplete submittals will not be considered.
  2. Quantities are Contractor's responsibility and will not be reviewed.
  3. Provide materials of the same brand or manufacturer for each class of equipment or material.
  4. Identify each item by manufacturer, brand, trade name, number, size, rating, or other data necessary to properly identify and review materials and equipment. Words "as specified" are not sufficient identification.
  5. Identify each submittal item by reference to items' Specification Section number and paragraph, by Drawing and detail number, and by unit tag number.
  6. Organize submittals in same sequence as in Specification Sections.
  7. Show physical arrangement, construction details, finishes, materials used in fabrications, provisions for piping entrance, access requirements for installation and maintenance, physical size, mechanical characteristics, foundation and support details, and weight.
    - a. Submit Shop Drawings, performance curves, and other pertinent data, showing size and capacity of proposed materials.
    - b. Specifically indicate, by drawn detail or note, that equipment complies with each specifically stated requirement of Contract Documents.
    - c. Drawings shall be drawn to scale and dimensioned (except schematic diagrams). Drawings may be prepared by vendor but must be submitted as instruments of Contractor, thoroughly checked and signed by Contractor before submission to Architect for review.
    - d. Catalog cuts and published material may be included with supplemental scaled drawings.
- B. Review of submittals will be only for general conformance with design concept and general compliance with information given in Contract Documents. Review will not include quantities, dimensions, weights or gauges, fabrication processes, construction methods, coordination with work of other trades, or construction safety precautions, which are sole responsibility of Contractor. Review of a component of an assembly does not indicate acceptance of an assembly. Deviations from Contract Documents not clearly identified by Contractor are Contractor's responsibility and will not be reviewed by Architect.
- C. Within reasonable time after award of contract and in ample time to avoid delay of construction, submit to Architect Shop Drawings or submittals on all items of equipment and materials provided. Provide submittal in at least seven copies and in complete package.
1. Shop Drawings and submittals shall include Specification Section, Paragraph number, and Drawing unit symbol or detail number for reference. Organize submittals into booklets for each Specification section and submit in loose-leaf binders with index. Deviations from the Contract Documents shall be prominently displayed in the front of the submittal package and referenced to the applicable Contract requirement.

#### 1.8 ACTION SUBMITTALS

- A. Product Data: Submit manufacturer's technical product data and installation instructions for plumbing systems materials and products.
1. Provide product data for insulation products, including insulation, insulation facings, jackets, adhesives, sealants, and coatings, indicating compliance with requirement that these products contain less than 0.1 percent (by mass) polybrominated diphenyl ethers (PBDEs) in penta, octa, or deca formulations.
  2. Pipe, pipe or plumbing fittings, fixtures, solder and flux installed in a system providing water for human consumption shall comply with lead free requirements of the California Health and Safety Code Section 116875. Provide submittal information for products



third-party certified by an approved laboratory as complying with California Health and Safety Code Section 116875.

- B. Delegated-Design Submittal: For seismic supports, anchorages, and restraints indicated to comply with performance requirements and design criteria.
1. Calculations performed for use in selection of seismic supports, anchorages, and restraints shall utilize criteria indicated in Structural Contract Documents.
  2. Supports, anchorage and restraints for piping, ductwork, and equipment shall be an OSHPD pre-approved system such as Tolco, ISAT, Mason, or equal. Pipes, ducts and equipment shall be seismically restrained in accordance with requirements of current edition of California Building Code. System shall have current OPM number and shall meet additional requirements of authority having jurisdiction. Provide supporting documentation required by the reviewing authority and the Architect and Engineer. Provide layout drawings showing piping, ductwork and restraint locations.
    - a. Bracing of Piping and Equipment: Specifically state how bracing attachment to structure is accomplished. Provide shop drawings indicating seismic restraints, including details of anchorage to building. In-line equipment must be braced independently of piping, and in conformance with applicable building codes. Provide calculations to show that pre-approval numbers have been correctly applied in accordance with general information notes of pre-approval documentation.
  3. In lieu of the above or for non-standard installations not covered in the above pre-approved systems, Contractor shall provide layout drawings showing piping, ductwork, and restraint locations, and detail supports, attachments and restraints, and furnish supporting calculations and legible details sealed by a California registered structural engineer, in accordance with 2016 California Building Code
  4. Additional Requirements: In addition to the above, conform to all state and local requirements.

#### 1.9 CLOSEOUT SUBMITTALS

- A. Operation and Maintenance Data:
1. Refer to Division 01 for complete instructions.
- B. Record Drawings:
1. Refer to Division 01, Record Documents, for requirements governing Work specified herein.
  2. Upon completion of the work, deliver to Architect the following:
    - a. Originals of drawings showing the Work exactly as installed.
    - b. One complete set of reproducible drawings showing the Work exactly as installed.
    - c. One compact disc with complete set of drawings in PDF format showing the Work exactly as installed.
    - d. Provide Contractor's signature, verifying accuracy of record drawings.
    - e. Obtain the signature of the Project Inspector for all record drawings.

#### 1.10 SUBSTITUTIONS

- A. Refer to Division 01 for complete instructions.

1.11 DELIVERY, STORAGE, AND HANDLING

- A. Protect equipment and piping delivered to Project site from weather, humidity and temperature variations, dirt, dust and other contaminants.

1.12 FIELD CONDITIONS

- A. Contractor shall visit Project site and examine existing conditions in order to become familiar with Project scope. Verify dimensions shown on Drawings at Project site. Bring discrepancies to the attention of Architect. Failure to examine Project site shall not constitute basis for claims for additional work because of lack of knowledge or location of hidden conditions that affect Project scope.
- B. Information on Drawings relative to existing conditions is approximate. Deviations from Drawings necessary during progress of construction to conform to actual conditions shall be approved by the Architect and shall be made without additional cost to the Owner. The Contractor shall be held responsible for damage caused to existing services. Promptly notify the Architect if services are found which are not shown on Drawings.

1.13 WARRANTY

- A. Refer to Division 01 for warranty requirements, including effective date of warranty. Refer to specific items of equipment specified herein for warranty duration if different from that specified in Division 01.
- B. Repair or replace defective work, material, or part that appears within the warranty period, including damage caused by leaks.
- C. On failure to comply with the above warranty within a reasonable length of time after notification is given, the Architect/Owner shall have the repairs made at the Contractor's expense.

PART 2 - PRODUCTS

2.1 GENERAL

- A. Materials or equipment of the same type shall be of the same brand wherever possible. All materials shall be new and in first class condition.
- B. All sizes, capacities, and efficiency ratings shown are minimum, except that gas capacity is maximum available.
- C. Refer to Sections 22 10 00 and 23 80 00 for specific system piping materials.

2.2 MATERIALS AND PRODUCTS

- A. No material installed as part of this Work shall contain asbestos.
- B. Insulation products, including insulation, insulation facings, jackets, adhesives, sealants and coatings shall not contain polybrominated diphenyl ethers (PBDEs) in penta, octa, or deca formulations in amounts greater than 0.1 percent (by mass).

2.3 ELECTRIC MOTORS

- A. General Motor Requirements: Comply with NEMA MG 1 unless otherwise indicated. Comply with IEEE 841 for severe-duty motors.

1. Manufacturers: Subject to compliance with requirements, available manufacturers offering products that may be incorporated into the Work include the following, or equal:
  - a. U.S. Motors.
  - b. Century Electric.
  - c. General Electric.
  - d. Lincoln.
  - e. Gould.
  
- B. Motor Characteristics: Designed for continuous duty at ambient temperature of 40 deg. C and at altitude of 3300 feet above sea level. Capacity and torque shall be sufficient to start, accelerate, and operate connected loads at designated speeds, at installed altitude and environment, with indicated operating sequence, and without exceeding nameplate ratings or considering service factor.
  1. Motors exceeding the nameplate amperage shall be promptly replaced at no cost to the Owner. Horsepower shown is minimum and shall be increased as necessary to comply with above requirements. Furnish motors with splash-proof or weatherproof housings, where required or recommended by the manufacturer. Match the nameplate voltage rating with the electrical service supplied. Check Electrical Drawings. Provide a transformer for each motor not wound specifically for system voltage.
  
- C. Polyphase Motors: NEMA MG 1, Design B, medium induction motor, premium efficiency as defined in NEMA MG 1. Select motors with service factor of 1.15. Provide motor with random-wound, squirrel cage rotor, and permanently lubricated or regreasable, shielded, antifriction ball bearings suitable for radial and thrust loading. Temperature rise shall match insulation rating. Provide Class F insulation.
  1. Multispeed motors shall have separate windings for each speed.
  
- D. Polyphase Motors with Additional Requirements:
  1. Motors Used with Reduced-Voltage and Multispeed Controllers: Match wiring connection requirements for controller with required motor leads. Provide terminals in motor terminal box, suited to control method.
  2. Motors Used with Variable Frequency Controllers:
    - a. Separately Connected Motors: Ratings, characteristics, and features coordinated with and approved by controller manufacturer.
    - b. Windings: Copper magnet wire with moisture-resistant insulation varnish, designed and tested to resist transient spikes, high frequencies, and short time rise pulses produced by pulse-width modulated inverters.
    - c. Energy- and Premium-Efficient Motors: Class B temperature rise; Class F insulation.
    - d. Inverter-Duty Motors: Class F temperature rise; Class H insulation.
    - e. Thermal Protection: Comply with NEMA MG 1 requirements for thermally protected motors.
    - f. Each motor shall be provided with a shaft grounding device for stray current protection.
  3. Severe-Duty Motors: Comply with IEEE 841, with 1.15 minimum service factor.
  
- E. Single-Phase Motors:
  1. Select motors with service factor of 1.15.

2. Motors larger than 1/20 hp shall be one of the following, to suit starting torque and requirements of specific motor application:
    - a. Permanent-split capacitor.
    - b. Split phase.
    - c. Capacitor start, inductor run.
    - d. Capacitor start, capacitor run.
  3. Multispeed Motors: Variable-torque, permanent-split-capacitor type.
  4. Bearings: Prelubricated, antifriction ball bearings or sleeve bearings suitable for radial and thrust loading.
  5. Motors 1/20 HP and Smaller: Shaded-pole type.
- F. Thermal Protection: Internal protection to automatically open power supply circuit to motor when winding temperature exceeds a safe value calibrated to temperature rating of motor insulation. Thermal-protection device shall automatically reset when motor temperature returns to normal range.

#### 2.4 MOTOR STARTERS

- A. Square D, Allen Bradley, or equal, in NEMA Type 1 enclosure, unless otherwise specified or required. Minimum starter size shall be Size 1. Provide NEMA 3R enclosure where exposed to outdoors.
- B. Provide magnetic motor starters for equipment provided under the Mechanical Work. Starters shall be non-combination type. Provide part winding or reduced voltage start motors where shown or as hereinafter specified. Minimum size starter shall be Size 1.
  1. All starters shall have the following:
    - a. Cover mounted hand-off-automatic switch. Starters installed exposed in occupied spaces shall have key operated HOA switch.
    - b. Ambient compensated thermal overload.
    - c. Fused control transformer (for 120 or 24 volt service).
    - d. Pilot lights, integral with the starters. Starters located outdoors shall be in NEMA IIIR enclosures.
  2. Where three phase motors are provided for two-speed operation, provide two speed motor starters.
  3. Starters for single-phase motors shall have thermal overloads. NEMA I enclosure for starters located indoors, NEMA IIIR enclosure for starters located outdoors.
  4. Provide OSHA label indicating the device starts automatically.

#### 2.5 VALVES AND FITTINGS FOR POTABLE WATER SYSTEMS

- A. General:
  1. Provide valves and fittings conforming to lead-free requirements of California Health and Safety Code Section 116875.
    - a. Provide valves listed to NSF/ANSI 61-G or NSF/ANSI 372 for valve materials for potable-water service.

- 1) Exception: Main distribution gate valves above 1-1/2 inches located underground outside building are not required to conform lead-free requirements of California Health and Safety Code Section 116875.

B. Gate Valves:

1. General: Furnish valves in copper lines with adapters to suit valve/line requirements.
2. 1-1/2 inches and smaller: Minimum 200 psi CWP, bronze body, threaded bonnet, rising or non-rising stem, solid wedge, threaded or solder ends, conforming to MSS SP-80. Milwaukee UP148, UP149, Nibco T-113-LF, S-113-LF, or equal.
3. 2 inches through 3 inches: Minimum 200 psi CWP, bronze body, threaded bonnet, non-rising stem, solid wedge, threaded or solder ends, conforming to MSS SP-80. Nibco T-113-LF, S-113-LF, or equal.
4. Main distribution gate valves underground outside building above 1-1/2 inches:
  - a. Underground valves 2 inches thru 12 inches: 250 psi, iron body, Non-rising stem, bolted bonnet, resilient wedge valves, conforming to AWWA C509, equipped with operating nuts, Mueller Series 2360, Nibco F-619-RW-SON, or equal.
    - 1) Underground valves 3 inches and smaller may be furnished with operating nuts or hand-wheels, and with Ring-Tite joint ends.
    - 2) Furnish and deliver to Owner one wrench of each size required for operating underground valves.

C. Ball Valves:

1. 2 inches and smaller: 600 psi CWP, cast bronze or brass body, full port, two piece, threaded ends, and reinforced PTFE seal, conforming to MSS SP-110. Nibco T-685-80-LF, Milwaukee UPBA400, Apollo 77C-LF10, Kitz 868, or equal.
2. 2-1/2 inches: Apollo 77C-LF10, or equal.

D. Swing Check Valves:

1. Minimum 200 psi CWP, bronze or brass body, suitable for regrinding, threaded ends, conforming to MSS SP-80. Milwaukee UP509, Nibco T-413LF, Kitz 822T, or equal.

E. Silent Check Valves (for use on pump discharge):

1. General: Provide spring loaded check valves at pump discharge of all pumps.
  - a. 2 inches and smaller: Minimum 300 psi CWP, bronze body, Apollo 61LF, Milwaukee UP548-T, or equal.
  - b. 2-1/2 inches and larger: Class 250, cast iron body, suitable for regrinding, Mueller 103MAP, or equal.

F. Calibrated Balancing Valves:

1. General: Calibrated orifice ball type rated for 400 psig maximum operating pressure and 250 degrees F. maximum operating pressure.
  - a. Body: Brass.
  - b. Ball: 304 Stainless Steel.
  - c. Seat: Glass and Carbon filled TFE.
  - d. End Connections: Threaded.

- e. Pressure Gage connections: Integral capped readout valves with internal check valves and drain port, for use with portable pressure differential meter.
  - f. Handle Style: Dial, with memory stops to retain set position.
2. Manufacturers: Subject to compliance with requirements, available manufacturers offering products that may be incorporated into the Work include the following, or equal:
- a. 1 inch and smaller: Bell & Gossett model CB, "LF" series.

## 2.6 VALVES AND FITTINGS FOR NON-POTABLE WATER, COMPRESSED AIR, AND GAS SYSTEMS

### A. Gas Shut-off Valve Above Grade:

- 1. 2 inches and smaller: Provide Milwaukee BB2-100, Jomar T-100NE, or equal, ball valve, CSA listed, full port.
- 2. Above 2 inches: Provide ReSun D-126, Key Port, or equal, CSA listed, rectangular port, full pipe area, 125 psi SWP, flanged ends. Provide T-Handle socket wrench and adapter fittings as required for operation of valves. Provide one package of spare lubricant sticks, sizes as required for valve sizes. Lubricant shall be the product recommended by valve manufacturer for use with type of gas conveyed by the piping system.
- 3. Provide valves same size as upstream piping. Make any reduction in size of gas piping downstream of shutoff valves.

## 2.7 JOINING MATERIALS

### A. Refer to Division 22 and 23 piping sections for special joining materials not listed below.

### B. Pipe-Flange Gasket Materials: Suitable for chemical and thermal conditions of piping system contents.

- 1. ASME B16.21, nonmetallic, flat, asbestos-free, 1/8-inch (3.2-mm) maximum thickness unless thickness or specific material is indicated
  - a. Full-Face Type: For flat-face, Class 125, cast iron and cast bronze flanges.
  - b. Narrow-Face Type: For raised-face, Class 250, cast iron and steel flanges.
- 2. AWWA C111, rubber, flat face, 1/8-inch (3.2mm) thick, unless otherwise indicated; and full-face or ring type, unless other indicated.
- 3. Flange Bolts and Nuts: AWWA C111, carbon steel, unless otherwise indicated.
- 4. Plastic, Pipe-Flange Gasket, Bolts and Nuts: Type and material recommended by piping system manufacturer, unless otherwise indicated.

### C. Brazing Filler Metals: AWS A5.8, BCup-5 Series, copper-phosphorus unless otherwise indicated. Sil-Fos 15, or equal.

### D. Welding Filler Metals: Comply with ASME B31.1 for welding materials appropriate for wall thickness and chemical analysis of steel pipe being welded.

## 2.8 GAUGES

- A. Marsh "Series J", U.S. Gage, Danton 800, or equal, with bronze bushed movement and front recalibration. Dials shall be white with black numerals, 3-1/2 inch dial face. Normal reading shall be at mid-scale. Provide a needle valve on each gauge connection. Supply a gauge

pip ed with branch isolation valves across the inlet and outlet of each pump and where shown on the Drawings.

- B. Provide Pete's Plug II, Sisco P/T, or equal, test plug with Nordel core {and gasketed cap}, on inlet and outlet of each coil, boiler, condenser, chiller and heat exchanger and where shown on Drawings.

## 2.9 THERMOMETERS

- A. Marsh, Taylor, Palmer, or equal, 5 inch diameter bimetal dial, adjustable from face, with adjustable positioner, located to be easily read from normal personnel approach. Normal reading shall be at mid-scale.

- 1. Provide extension for insulation.
- 2. Provide thermometers with steel bulb chambers and brass separable sockets.

- B. Provide Pete's Plug II, Sisco P/T, or equal, test plug with Nordel core, on inlet and outlet of each coil, boiler, and heat exchanger and provide two digital electronic test thermometers for each range of fluid temperature and where shown on Drawings.

## 2.10 ACCESS DOORS

- A. Where floors, walls, or ceilings must be penetrated for access to mechanical equipment, provide access doors, 14 inch by 14 inch minimum size in usable opening. Where entrance of a serviceman may be required, provide 20 inch by 30 inch minimum usable opening. Locate access doors/panels for non-obstructed and easy reach.

- 1. All access doors less than 7'-0" above floors and exposed to public access shall have keyed locks.

- B. Access doors shall match those supplied in Division 08 in all respects, except as noted herein.

- C. Provide stainless steel access doors for use in toilet rooms, shower rooms, kitchens and other damp areas. Provide steel access doors with prime coat of baked-on paint for all other areas.

- D. Do not locate access doors in highly visible public areas such as lobbies, waiting areas, and primary entrance areas. Coordinate with the Architect when access is required in these areas.

- E. Where specific information or details relating to access panels different from the above is shown or given on the Drawings or other Divisions of work, then that information shall supersede this specification.

- F. Manufacturers: Subject to compliance with requirements, available manufacturers offering products which may be incorporated into the Work include Milcor, Karp, Nystrom, or Cesco, equal to the following:

- 1. Milcor
  - a. Style K (plaster).
  - b. Style DW (gypsum board).
  - c. Style M (Masonry).
  - d. Style "Fire Rated" where required.

2.11 PIPE GUIDES

- A. Where flexible connections are indicated on Drawings, provide Metraflex style IV, B-Line, or equal, pipe guides in locations recommended by manufacturer. Maximum spacing from flexible connection to first pipe guide is 4 pipe diameters, and maximum spacing from second pipe guide is 14 pipe diameters.

2.12 EQUIPMENT IDENTIFICATION

- A. Identify each piece of equipment with a permanently attached engraved bakelite plate, 1/2 inch high white letters on black background.

2.13 PIPE IDENTIFICATION

- A. Identify each piping system and indicate the direction of flow by means of Seton, Inc., Marking Services Inc., Reef Industries, Inc., or equal, pre-tensioned, coiled semi-rigid plastic pipe labels formed to circumference of pipe, requiring no fasteners or adhesive for attachment to pipe.
- B. The legends and flow arrows shall conform to ASME A13.1.

2.14 INSULATION WORK

- A. General:
  - 1. Insulation products, including insulation, insulation facings, jackets, adhesives, sealants and coatings shall not contain polybrominated diphenyl ethers (PBDEs) in penta, octa, or deca formulations in amounts greater than 0.1 percent (by mass).
  - 2. Adhesives and sealants shall comply with testing and product requirements of South Coast Air Quality Management District, Rule 1168.
  - 3. The term "piping" used herein includes pipe, valves, strainers and fittings.
  - 4. Apply insulating cement to fittings, valves and strainers and trowel smooth to the thickness of adjacent covering. Cover with jacket to match piping. Extend covering on valves up to the bonnet. Leave strainer cleanout plugs accessible.
  - 5. Provide pre-formed PVC valve and fitting covers.
  - 6. Provide Calcium Silicate rigid insulation and sheet metal sleeve, 18 inch minimum length at each pipe hanger. Seal ends of insulation to make vapor tight with jacket.
  - 7. Test insulation, jackets and lap-seal adhesives as a composite product and confirm flame spread of not more than 25 and a smoke developed rating of not more than 50 when tested in accordance with UL723 or ASTM E84.
  - 8. Clean thoroughly, test and have approved, all piping and equipment before installing insulation and/or covering.
  - 9. Repair all damage to existing pipe and equipment insulation whether or not caused during the work of this contract, to match existing adjacent insulation for thickness and finish, but conforming to flame spread and smoke ratings specified above.
- B. Insulation of Piping:
  - 1. Insulate domestic hot and tempered water with minimum 3-1/2 pounds per cubic foot density fiberglass with ASJ-SSL jacket. Insulation thickness shall be the following:
    - a. Pipe 3/4 inches and smaller: 1 inch thick.
    - b. Pipe 1 inch through 1-1/2 inches: 1-1/2 inches thick.
    - c. Pipe 2 inches and larger: 2 inches thick.



2. Exposed insulated piping within the building shall have a Zeston 2000 25/50, Proto Lo-Smoke, or equal, PVC jacket and fitting cover installed over the insulation, applied per manufacturer's instructions. Insulation shall be vapor tight before applying PVC jacket and fitting covers. Verify suitability with manufacturer of insulation. Insulation with pre-applied polymer jacket may be substituted at Contractor's option.
3. Where insulated piping is exposed to the weather apply aluminum jacket secured with 1/2 inch stainless-steel bands on 12 inch centers. Insulation shall be vapor tight before applying metal jacket, and aluminum fitting covers. Install jacketing with 2-inch overlap at longitudinal seams and end joints. Overlap longitudinal seams arranged to shed water. Seal end joints with weatherproof sealant recommended by insulation manufacturer. Cover fittings with glass cloth, two coats of Foster Sealfas 30-36, and factory-fabricated aluminum fitting covers, of same material, finish, and thickness as jacket. Insulation shall be vapor tight before applying metal jacket and fitting covers.
  - a. Fitting covers:
    - 1) Preformed 2-piece or gore, 45- and 90-degree, short- and long-radius elbows.
    - 2) Tee covers.
    - 3) Flange and union covers.
    - 4) End caps.
    - 5) Beveled collars.
    - 6) Valve covers.
    - 7) Field fabricate fitting covers only if factory-fabricated fitting covers are not available.
  - b. Jacket thickness:
    - 1) Pipes 10 inches diameter and smaller: Minimum .016 inch thick jacket with smooth finish.
    - 2) Pipes 12 inches diameter and larger: Minimum .020 inch thick jacket with smooth finish.

### PART 3 - EXECUTION

#### 3.1 EXISTING MATERIALS

- A. Remove existing equipment, piping, wiring, construction, etc., which interferes with Work of this Contract. Promptly return to service upon completion of work in the area. Replace items damaged by Contractor with new material to match existing.
- B. Removed materials which will not be re-installed and which are not claimed by Owner shall become property of Contractor and shall be removed from Project site. Consult Owner before removing any material from Project site. Carefully remove materials claimed by Owner to prevent damage and deliver to Owner-designated storage location.
- C. Existing piping and wiring not reused and are concealed in building construction may be abandoned in place and all ends shall be capped or plugged. Remove unused piping and wiring exposed in Equipment Rooms or occupied spaces. Material shall be removed from Project premises. Disconnect power, water, gas, pump or any other active energy source from piping or electrical service prior to abandoning in place.
- D. Existing piping, ductwork, and equipment modified or altered as part of this Work shall comply with the most recent applicable code requirements.

### 3.2 FRAMING, CUTTING AND PATCHING

- A. Special framing, recesses, chases and backing for Work of this Section, unless otherwise specified, are covered under other Specification Sections.
- B. Contractor is responsible for placement of pipe sleeves, hangers, inserts, supports, and location of openings for the Work.
- C. Cutting, patching, and repairing of existing construction to permit installation of equipment, and materials is the responsibility of Contractor. Repair or replace damage to existing work with skilled mechanics for each trade.
- D. Cut existing concrete construction with a concrete saw. Do not utilize pneumatic devices.
- E. Core openings through existing construction for passage of new piping and conduits. Cut holes of minimum diameter to suit size of pipe and associated insulation installed. Coordinate with building structure, and obtain Structural Engineer's approval prior to coring through existing construction.

### 3.3 PLUMBING DEMOLITION

- A. Refer to Division 01 Sections "Cutting and Patching" and "Selective Demolition" for general demolition requirements and procedures.
- B. Disconnect, dismantle and remove mechanical systems, equipment, and components indicated to be removed. Coordinate with all other trades.
  - 1. Piping to Be Removed: Remove portion of piping indicated to be removed and cap or plug remaining piping with same or compatible piping material.
  - 2. Piping to Be Abandoned in Place: Drain piping and cap or plug piping to remain with same or compatible piping material. Refrigerant system must be evacuated per EPA requirements.
  - 3. Equipment to Be Removed: Drain down and cap remaining services and remove equipment.
  - 4. Equipment to Be Removed and Reinstalled: Disconnect and cap services and remove, clean, and store equipment; when appropriate, reinstall, reconnect, and make equipment operational.
  - 5. Equipment to Be Removed and Salvaged: Disconnect and cap services and remove equipment and deliver to Owner.
- C. If pipe, insulation, or equipment to remain is damaged in appearance or is unserviceable, remove damaged or unserviceable portions and replace with new products of equal capacity and quality.

### 3.4 ELECTRICAL REQUIREMENTS

- A. Provide adequate working space around electrical equipment in compliance with the California Electrical Code. Coordinate the Mechanical Work with the Electrical Work to comply.
- B. Furnish necessary control diagrams and instructions for the controls. Before permitting operation of any equipment which is furnished, installed, or modified under this Section, review all associated electrical work, including overload protection devices, and assume complete responsibility for the correctness of the electrical connections and protective devices. Motors and control equipment shall conform to the Standards of the National Electrical Manufacturers' Association. All equipment and connections exposed to the weather shall be NEMA III R with

factory-wired strip heaters in each starter enclosure and temperature control panel where required to inhibit condensation.

- C. All line voltage and low voltage wiring and conduit associated with the Temperature Control System are included in this Section. Wiring and conduit shall comply with Division 26.

### 3.5 PIPING SYSTEM REQUIREMENTS

- A. Drawing plans, schematic and diagrams indicate general location and arrangement of piping systems. Indicated locations and arrangements were used to size pipe and calculate friction loss, expansion, pump sizing, and other design considerations. Install piping as indicated unless deviations to layout are approved on coordination drawings.

### 3.6 PRIMING AND PAINTING

- A. Perform all priming and painting on the equipment and materials as specified herein.
- B. Priming:
  - 1. Exposed ferrous metals, including piping, which are not galvanized or factory-finished shall be primed. Black steel pipe exposed to the weather shall be painted one coat of Rust-Oleum #1069 primer for black steel piping or Rust-Oleum #5260, Kelly Moore, or equal, primer for galvanized piping.
  - 2. Metal surfaces of items to be jacketed or insulated except piping shall be given two coats of primer unless furnished with equivalent factory finish. Items to be primed shall be properly cleaned by effective means free of rust, dirt, scale, grease and other deleterious matter and then primed with the best available grade of zinc rich primer. After erection or installation, all primed surfaces shall be properly cleaned of any foreign or deleterious matter that might impair proper bonding of subsequent paint coatings. Any abrasion or other damage to the shop or field prime coat shall be properly repaired and touched up with the same material used for the original priming.
  - 3. Where equipment is provided with nameplate data, the nameplate should be masked off prior to painting. When painting is completed, remove masking material.
- C. See Painting Section for detailed requirements.

### 3.7 INSTALLATION OF VALVES

- A. Install valves as indicated on Drawings and in the following locations:
  - 1. Shutoff Valves: Install on inlet of each plumbing equipment item, and on inlet of each plumbing fixture, and elsewhere as indicated.
  - 2. Drain Valves: Install on each plumbing equipment item located to completely drain equipment for service or repair. Install at base of each riser, at base of each rise or drop in piping system, and elsewhere indicated or required to completely drain potable water system.
  - 3. Provide gate or globe valves on inlet and outlet of each water heater or pump.
- B. General:
  - 1. Valves shall be full line size unless indicated otherwise on Drawings.
  - 2. Install horizontal valves with valve stem above horizontal, except butterfly valves.
  - 3. Install valves with unions or flanges at each piece of equipment arranged to allow service, maintenance, and equipment removal without system shutdown.
  - 4. Locate valves for easy access and provide separate support where necessary.

5. Install valves in position to allow full stem movement.
6. Install exposed polished or enameled connections with special care showing no tool marks or exposed threads.
7. Butterfly valves conforming to the paragraph "Butterfly Valves" may be used in lieu of gate or globe valves for locations above grade.
8. Ball valves conforming to the paragraph "Ball Valves" may be used in lieu of gate valves for locations above grade for services 2-1/2 inches and smaller.
9. Valves 2-1/2 inches and smaller (except ball valves) in nonferrous water piping systems may be solder joint type with bronze body and trim.
10. Rigidly fasten hose bibbs, hydrants, fixture stops, compressed air outlets, and similar items to the building construction.

C. Gate Valves:

1. Furnish valves in copper lines with adapters to suit valve / line requirements.
2. Underground gate valves:
  - a. Underground valves 3 inches and smaller may be furnished with operating nuts or hand-wheels, and with Ring-Tite joint ends.
  - b. Furnish and deliver to Owner one wrench of each size required for operating underground valves.

D. Swing Check Valves: Install in horizontal position with hinge pin level.

E. Silent Check Valves: Install in horizontal or vertical position between flanges.

F. Calibrated Balancing Valves: Install calibrated balancing valves per manufacturers' recommendations, including requirements for straight pipe lengths at valve inlet and outlet.

G. Gas Shut-Off Valves:

1. Provide line size ball valve in gas line to each appliance.

H. Valve Adjustment: Adjust or replace valve packing after piping systems have been tested and put into service but before final adjusting and balancing. Replace valves if persistent leaking occurs.

### 3.8 INSTALLATION OF PIPING SYSTEMS

A. At time of final connection, and prior to opening valve to allow pressurization of water and gas piping from existing systems, on site or off site, perform a pressure test to indicate static pressure of existing systems. If pressure on water piping is greater than 80 psi, or gas pressure is not as indicated on Contract Documents, inform Architect immediately. Do not allow piping systems to be pressurized without written consent of the Architect.

B. General:

1. All piping shall be concealed unless shown or otherwise directed. Allow sufficient space for ceiling panel removal.
2. Installation of piping shall be made with appropriate fittings. Bending of piping will not be accepted.
3. Install piping to permit application of insulation and to allow valve servicing.
4. Where piping or conduit is left exposed within a room, the same shall be run true to plumb, horizontal, or intended planes. Where possible, uniform margins are to be maintained between parallel lines and/or adjacent wall, floor, or ceiling surfaces.

5. Horizontal runs of pipes and/or electrical conduit suspended from ceilings shall provide for a maximum headroom clearance. The clearance shall not be less than 6'-6" without written approval from the Architect.
6. Close ends of pipe immediately after installation. Leave closure in place until removal is necessary for completion of installation.
7. Each piping system shall be thoroughly flushed and proved clean before connection to equipment.
8. Pipe the discharge of each relief valve, air vent, backflow preventer, and similar device to floor sink or drain.
9. Install exposed polished or enameled connections with special care showing no tool marks or threads at fittings.
10. Install horizontal valves with valve stem above horizontal.
11. Use reducing fittings; bushings shall not be allowed. Use eccentric reducing fittings wherever necessary to provide free drainage of lines and passage of air.
12. Verify final equipment locations for roughing-in.
13. Service Markers: Mark the location of each plugged or capped pipe with a 4 inch round by 30 inch long concrete marker, set flush with finish grade. Provide 2-1/2 inch diameter engraved brass plate as part of monument marker.
14. Furnish and install anchors or thrust blocks on PVC water lines in the ground, at all changes in direction of piping, and at all connections or branches from mains 1-1/2 inch and larger. Form anchors or thrust blocks by pouring concrete between pipe and trench wall. Thrust blocks shall be of adequate size and so placed as to take thrusts created by maximum internal water pressure. Sizing and placement shall be per manufacturer's recommendations, CPC, and IAPMO installation standards. Anchor piping to building construction.
15. Sanitary Sewer : Grade piping inside building uniformly 1/4 inch per foot if possible but not less than 1/8 inch per foot. Run piping as straight as possible. Make piping connections between building piping and outside service pipe with cast iron reducers or increasers. Slope sewers uniformly between given elevations where invert elevations are shown.
16. Where piping is installed in walls within one inch of the face of stud, provide a 16 gauge sheet metal shield plate on the face of the stud. The shield plate shall extend a minimum of 1-1/2 inches beyond the outside diameter of the pipe.

C. Sleeves:

1. Install Adjus-to-Crete, Pipeline Seal and Insulator, or equal, pipe sleeves of sufficient size to allow for free motion of pipe, 24 gauge galvanized steel. The space between pipe and sleeves through floor slabs on ground, through outside walls above or below grade, through roof, and other locations as directed shall be caulked with oakum and mastic and made watertight. The space between pipe and sleeve and between sleeve and slab or wall shall be sealed watertight.
2. At Contractor's option, Link-Seal, Metraflex Metraseal, or equal, casing seals may be used in lieu of caulking. Wrap pipes through slabs on grade with 1 inch thick fiberglass insulation to completely isolate the pipe from the concrete.

D. Floor, Wall, and Ceiling Plates:

1. Fit all pipes with or without insulation passing through walls, floors, or ceilings, and all hanger rods penetrating finished ceilings with chrome-plated or stainless escutcheon plates.

E. Flashing:

1. Flashing for penetrations of metal or membrane roof for mechanical items such as flues and pipes shall be coordinated with the roofing manufacturer and roofing installer for the

specific roofing type. The work of this section shall include furnishing, layout, sizing, and coordination of penetrations required for the mechanical work.

- a. Furnish and install flashing and counterflashing in strict conformance with the requirements of the roofing manufacturer. Submit shop drawing details for review prior to installation.
  - b. Furnish and install counterflashing above each flashing required. Provide Stoneman, or equal, vandalproof top and flashing combination. Provide vandalproof top for each plumbing vent through roof. Elmdor/Stoneman Model 1540, 1550, 1570, or equal.
2. For all other types of roofing system, furnish and install around each pipe, where it passes through roof, a flashing and counterflashing. All flashing shall be made of four pound seamless sheet lead with 6 inch minimum skirt and steel reinforced boot. Counterflashing shall be cast iron. For vents, provide vandalproof top and flashing combination. Elmdor/Stoneman Model 1100-4, 1100-5, 1100-7, or equal.

F. Hangers and Supports:

- 1. General: Support equipment and piping so that it is firmly held in place by approved iron hangers and supports and special hangers. Hanger and support components shall support weight of equipment and pipe, fluid, and pipe insulation based on spacing between supports with minimum factor of safety of five based on ultimate strength of material used. Do not exceed manufacturer's load rating. Pipe attachments or hangers, of same size as pipe or tubing on which used, or nearest available. Rigidly fasten hose faucets, fixture stops, compressed air outlets, and similar items to the building construction. The Architect shall approve hanger material before installation. Do not support piping with plumbers' tape, wire rope, wood, or other makeshift devices. Where building structural members do not match piping support spacing, provide "bridging" support members firmly attached to building structural members in a fashion approved by the structural engineer.
  - a. Materials, design, and type numbers per Manufacturers' Standardization Society (MSS), Standard Practice (SP)-58.
    - 1) Provide copper-plated or felt-lined hangers for use on copper tubing.
- 2. Hanger components shall be provided by one manufacturer: B-Line, Grinnell, Unistrut, Badger, or equal.
- 3. Riser clamps: B-line model B3373, or equal.
- 4. Pipe Hanger and Support Placement and Spacing:
  - a. Vertical piping support spacing: Provide riser clamps for piping, above each floor, in contact with the floor. Provide support at joints, branches, and horizontal offsets. Provide additional support for vertical piping, spaced at or within the following maximum limits:

<u>Pipe Diameter</u>	<u>Steel Threaded or Welded (Note 3)</u>	<u>Steel Gas</u>	<u>Copper Brazed or Soldered (Note 3)</u>	<u>CPVC &amp; PVC (Note 2)</u>

1/2 - 1"	12 ft.	6 ft.	Each Floor, Not to Ex- ceed 10 ft.	Base and Each Floor (Note 1)
1-1/4 - 2"	12 ft.	Each Floor, Not to Ex- ceed 10 ft.	Each Floor, Not to Ex- ceed 10 ft..	Base and Each Floor (Note 1)
2-1/2 - 3"	12 ft.	Each Floor, Not to Ex- ceed 10 ft.	Each Floor, Not to Ex- ceed 10 ft.	Base and Each Floor (Note 1)
Over 4"	12 ft.	Each Floor, Not to Ex- ceed 10 ft.	Each Floor, Not to Ex- ceed 10 ft.	Base and Each Floor (Note 1)

Note 1: Provide mid-story guides.

Note 2: For PVC piping, provide for expansion every 30 feet per IAPMO installation standard. For CPVC piping, provide for expansion per IAPMO installation standard.

Note 3: Spacing of hangers and supports for piping assembled with mechanical joints shall be in accordance with standards acceptable to authorities having jurisdiction.

- b. Vertical cast iron piping support spacing: Base and each floor not to exceed 15 feet.
- c. Horizontal piping, hanger and support spacing: Locate hangers and supports at each change of direction, within one foot of elbow, and spaced at or within following maximum limits:

<u>Pipe Diameter</u>	<u>Steel Threaded or Welded (Note 2)</u>	<u>Steel Gas</u>	<u>Copper Brazed or Soldered (Notes 2, 3)</u>	<u>CPVC &amp; PVC (Note 1)</u>
1/2 - 1"	6 ft.	6 ft.	5 ft.	3 ft.
1-1/4 - 2"	7 ft.	10 ft.	6 ft.	4 ft.
2-1/2 - 3"	10 ft.	10 ft.	10 ft.	4 ft.
Over 4"	10 ft.	10 ft.	10 ft.	4 ft.

Note 1: For PVC piping, provide for expansion every 30 feet per IAPMO installation standard. For CPVC piping, provide for expansion per IAPMO installation standard.

Note 2: Spacing of hangers and supports for piping assembled with mechanical joints shall be in accordance with standards acceptable to authorities having jurisdiction.

Note 3: Includes all refrigerant piping, including vapor and hot gas pipes.

- d. Horizontal cast iron piping support spacing:
  - 1) Support piping at every other joint for piping length of less than 4 feet.

- 2) For piping longer than 4 feet, provide support on each side of the coupling, within 18 inches of each joint.
- 3) Hanger shall not be installed on the coupling.
- 4) Provide support at each horizontal branch connection.
- 5) Provide sway brace at 40 foot maximum spacing for suspended pipe with no-hub joints, except where a lesser spacing is required by the seismic design criteria used in delegated design for seismic systems. Refer to Article, Submittals.
- 6) Provide a brace on each side of a change in direction of 90 degrees or more.

5. Suspended Piping:

- a. Individually suspended piping: B-Line B3690 J-Hanger or B3100 Clevis, complete with threaded rod, or equal. All hangers on supply and return piping handling heating hot water or steam shall have a swing connector at point of support.

<u>Pipe Size</u>	<u>Rod Size Diameter</u>
2" and Smaller	3/8"
2-1/2" to 3-1/2"	1/2"
4" to 5"	5/8"
6"	3/4"

- b. Trapeze Suspension: B-Line 1-5/8 inch width channel in accordance with manufacturer's published load ratings. No deflection to exceed 1/180 of a span.
- c. Trapeze Supporting Rods: Shall have a safety factor of five; securely anchor to building structure.
- d. Pipe Clamps and Straps: B-Line B2000, B2400; isolate copper pipe with two thicknesses of 2 inches wide 10-mil polyvinyl tape. Where used for seismic support systems, provide B-Line B2400 series pipe straps.

6. Support to Structure:

- a. Wood Structure: Provide and install wood blocking as required to suit structure. Provide lag screws or through bolts with length to suit requirements, and with size (diameter) to match the size of hanger rods required.

- 1) Do not install Lag screws in tension without written review and acceptance by Structural Engineer.

Side Beam Angle Clip	B-Line B3062    MSS Type 34
Side Beam Angle Clip	B-Line B3060
Ceiling Flange	B-Line B3199

- 2) Blocking for support of piping shall be not less than 2 inch thick for piping up to 2 inch size. Provide 3 inch blocking for piping up through 5 inch size, and 4 inch blocking for larger piping. Provide support for blocking in accordance with Structural Engineers requirements.



- 3) Where lag screws are used, length of screw shall be 1/2 inch less than the wood blocking. Pre-drill starter holes for each lag screw.

7. Rubber Neoprene Pipe Isolators:

- a. Pipe isolators shall comprise an internal rubber or neoprene material that isolates pipe from hanger and structure. Install at all piping located in acoustical walls. Refer to Architectural Drawings for location of acoustical walls.
- b. Isolation material shall be either a rubber or neoprene material that prevents contact between the pipe and the structure. The rubber shall have between a 45 to 55 durometer rating and a minimum thickness of 1/2 inch.
- c. Acceptable Suppliers:
  - 1) Vertical runs: Acousto-Plumb or equal.
  - 2) Horizontal runs: B-Line, Vibraclamp; Acousto-Plumb or equal.

8. Provide support for piping through roof, arranged to anchor piping solidly in place at the roof penetration.
9. Provide rigid insulation and a 12 inch long, 18 gauge galvanized sheet iron shield between the covering and the hanger whenever hangers are installed on the outside of the pipe covering.
10. Insulate copper tubing from ferrous materials and hangers with two thicknesses of 3 inch wide, 10 mil polyvinyl tape wrapped around pipe.
11. Provide a support or hanger close to each change of direction of pipe either horizontal or vertical and as near as possible to concentrated loads.
12. Suspend rods from concrete inserts with removable nuts where suspended from concrete decks. Power actuated inserts will not be allowed.

3.9 PIPE JOINTS AND CONNECTIONS

A. General:

1. Cutting: Cut pipe and tubing square, remove rough edges or burrs. Bevel plain ends of steel pipe.
2. Remove scale, slag, dirt and debris from inside and outside of pipe before assembly.
3. Boss or saddle type fittings or mechanically extracted tube joints will not be allowed.

B. Threaded Pipe: Thread pipe with tapered pipe threads according to ASME B1.20.1. Cut threads full and clean using sharp dies. Ream threaded pipe ends to remove burrs and restore full ID. Join pipe fittings and valves as follows:

1. Apply thread compound to external pipe threads: Rectorseal No. 5, Permatex No. 1, or equal.
2. Damaged Threads: Do not use pipe or pipe fittings with threads that are corroded or damaged.

C. Flanged Joints: Select appropriate asbestos-free, nonmetallic gasket material in size, type, and thickness suitable for domestic water service. Join flanges with gasket and bolts according to ASME B31.9.

D. Copper Pipe and Tubing (Except pneumatic control piping): All joints shall be brazed according to ASME Section IX, Welding and Brazing Qualifications, except domestic water piping 1-1/4 inches and smaller when not buried in the ground or concrete and type DWV plumbing piping may be soldered.

1. Soldered joints: Apply water-flushable flux to end of tube. Join copper tube and fittings according to ASTM B 828.

E. Cast Iron Soil Pipe:

1. No-Hub fittings shall be made with a torque wrench.
2. Hub joints shall be with Ty-Seal couplings.
3. Wrought iron, steel, or copper pipe shall have a ring or part of a coupling screwed on to form a spigot end if caulked into a joint.
4. Connect cast iron sewer piping to outside service pipe with cast iron or vitrified clay reducers or increasers as required. Caulking of smaller pipe into the larger without a reducer or increaser will not be permitted.

F. Welded Pipe:

1. Make up with oxyacetylene or electric arc process.
2. All welding shall conform to the American Standard Code for Power Piping ASME B-31.1. When requested by the Architect, furnish certification from an approved testing agency or National Certified Pipe Welding Bureau that the welders performing the work are qualified.
3. All line welds shall be of the single "V" butt type. Welds for flanges shall be of the fillet type.
4. Where the branch is two pipe sizes smaller than the main or smaller, Bonney Weldolets, Threadolets, Nibco, or equal, may be used in lieu of welding tees.

G. Flexible Connections:

1. Furnish and install Thermo Tech., Inc. F/J/R, Metraflex, or equal, flexible couplings with limiter bolts on piping connections to all equipment mounted on anti-vibration bases, on each connection to each base mounted pump and where shown. Couplings shall be suitable for pressure and type of service.
2. Anchor piping securely on the system side of each flexible connection.

### 3.10 UNIONS AND FLANGES

- A. Install Watts, Epco, Nibco, or equal, dielectric unions or flanges at points of connection between copper or brass piping or material and steel or cast iron pipe or material except in drain, waste, vent, or rainwater piping. Bushings or couplings shall not be used. Dielectric unions installed in potable water systems shall conform to the lead-free requirements of the California Health and Safety Code Section 116875.
- B. Install unions in piping NPS 2" and smaller, and flanges in piping NPS 2-1/2" and larger whether shown or not at each connection to all equipment and tanks, and at all connections to all automatic valves, such as temperature control valves. Unions installed in potable water systems shall conform to the lead-free requirements of the California Health and Safety Code Section 116875.
- C. Locate the unions for easy removal of the equipment, tank, or valve.

### 3.11 ACCESS DOOR

- A. Furnish and install access doors wherever required whether shown or not for easy maintenance of mechanical systems; for example, at concealed valves, strainers, traps, cleanouts, dampers, motors, controls, operating equipment, etc. Access doors shall provide for complete removal and replacement of equipment.

3.12 CONCRETE WORK

- A. Concrete work required for work of this Section shall be included under another section of the Specification, unless otherwise noted, including poured-in-place concrete work for installing precast manholes, catch basins, etc., and shall include reinforced concrete bases for pumps, tanks, compressors, fan units, boilers, unless the work is specifically indicated on the Drawings to be furnished under this Section.
- B. Thrust blocks, underground anchors, and pads for cleanouts, valve access boxes and washer boxes are included under this Section of the Specification. Concrete shall be 3000 psi test minimum. Refer to Division 03 for concrete types.

3.13 PIPE PROTECTION

- A. Wrap bare galvanized and black steel pipe buried in the ground and to 6" above grade, including piping in conduit, with one of the following, or equal:
  - 1. Polyethylene Coating: Pressure sensitive polyethylene coating, "X-Tru-Coat" as manufactured by Pipe Line Service Corporation or "Green Line" wrap as manufactured by Royston Products, or equal.
    - a. Field Joints and Fittings: Protecto Wrap #1170 tape as manufactured by Pipe Line Service Corporation, or Primer #200 tape by Royston Products, or equal. Installation shall be as per manufacturer's recommendation and instructions.
  - 2. Tape Wrap: Pressure-sensitive polyvinyl chloride tape, "Transtex #V-10 or V-20", "Scotchwrap 50", Slipknot 100, PASCO Specialty & Mfg., Inc., or equal, with continuous identification. Tape shall be a minimum of 20 mils thick for fittings and irregular surfaces, two wraps, 50 percent overlap, 40 mils total thickness. Tape shall be laminated with a suitable adhesive; widths as recommended by the manufacturer for the pipe size. Wrap straight lengths of piping with an approved wrapping machine.
- B. Field Joints: Valves and Fittings: double wrap polyvinyl chloride tape as above. Provide at least two thicknesses of tape over the joint and extend a minimum of 4 inches over adjacent pipe covering. Build up with primer to match adjacent covering thickness. Width of tape of fittings shall not exceed 3 inches. Tape shall adhere tightly to all surfaces of the fittings without air pockets.
- C. Testing: Test completed wrap of piping, including all epoxy painted piping with Tinker and Razor Co. test machine (San Gabriel, CA - 818-287-5259), Pipeline Inspection Company (Houston, TX - 713-681-5837), or equal.
- D. Cleaning: Clean all piping thoroughly before wrapping.
  - 1. Inspection: Damaged or defective wraps shall be repaired as directed. No wrapped pipe shall be covered until approved by Architect.
- E. Sleeve copper piping/tubing installed below slab with "Polywrap-C" polyethylene sleeve, as manufactured by Northtown Pipe Protection Products, or equal. Sleeve shall be a minimum of 6 mils thick, colored blue for domestic water piping and orange for other piping. Install sleeve per manufacturer's recommendations and instructions.
- F. Sleeve copper piping/tubing installed outside building below grade with "Polywrap-C" polyethylene sleeve, as manufactured by Northtown Pipe Protection Products, or equal.

Sleeve shall be a minimum of 6 mils thick, colored blue for domestic water piping. Install sleeve per manufacturer's recommendations and instructions.

- G. Sleeve cast iron and ductile iron pipe below grade and below slab with "Polywrap" polyethylene sleeve, as manufactured by Northtown Pipe Protection Products, or equal. Sleeve shall be a minimum of 8 mils thick, colored natural. Install sleeve per manufacturer's recommendations and instructions.
- H. Covering: No rocks or sharp edges shall be backfilled against the wrap or sleeve. When backfilling with other than sand, protect wrap with an outer wrapping of Kraft paper; leave in place during backfill.

### 3.14 PIPE IDENTIFICATION

- A. Provide temporary identification of each pipe installed, at the time of installation. Temporary identification shall be removed and replaced with permanent identification as part of the work.
- B. Apply the legend and flow arrow at all valve locations; at all points where the piping enters or leaves a wall, partition, cluster of piping or similar obstruction, at each change of direction and at approximately 20'-0" intervals on pipe runs. Variations or changes in locations and spacing may be made with the approval of the Architect. There shall be at least one marking in each room. Markings shall be located for maximum visibility from expected personnel approach.
- C. Wherever two or more pipes run parallel, the markings shall be supplied in the same relative location on each.
- D. Apply markings after painting and cleaning of piping and insulation is completed.

### 3.15 PIPING SYSTEM PRESSURE TESTING

- A. General:
  - 1. Perform operational tests under simulated or actual service conditions, including one test of complete plumbing installation with fixtures and other appliances connected.
  - 2. Repair leaks and defects with new materials, and retest piping or portion thereof until satisfactory results are obtained.
- B. Piping Systems: Test piping systems in accordance with the following requirements and applicable codes:
  - 1. Authority having jurisdiction shall witness tests of piping systems.
  - 2. Notify Architect at least seven days in advance of testing.
  - 3. All piping shall be tested at completion of roughing-in, or at other times as directed by Architect.
  - 4. Furnish necessary materials, test pumps, gases, instruments and labor required for testing.
  - 5. Isolate from system equipment that may be damaged by test pressure.
  - 6. Make connections to existing systems with flanged connection. During testing of new work, provide a slip-in plate to restrict test pressure to new systems. Remove plate and make final connection to existing system at completion of testing.
    - a. Authority having jurisdiction shall witness final connection to system.
- C. Test Schedule: No loss in pressure or visible leaks shall show after four hours at the pressures indicated.

- D. Testing of Sanitary Sewer, Drain, Vent, and Storm Drain may be done in segments in order to limit pressure to within manufacturer’s recommendations. Test to 10 feet above highest point in the system.

<u>System Tested</u>	<u>Test Pressure PSI</u>	<u>Test With</u>
Sanitary Sewer, Drain, Vent	10 Ft. Hd.	Water
Storm Drain, Condensate Drains	10 Ft. Hd.	Water
Domestic Water	125	Water
Natural Gas (Steel)	100	Air & Non-corrosive Leak Test Fluid

1. Non-corrosive leak test fluid shall be suitable for use with piping material specified, and with the type of gas conveyed by the piping system.

3.16 OPERATION OF SYSTEMS

- A. Do not operate any plumbing equipment for any purpose, temporary or permanent, until all of the following has been completed:
1. Complete all requirements listed under “Check, Test and Start Requirements.”
  2. Piping has been properly cleaned. Piping systems shall be flushed and treated prior to operation.
  3. Filters, strainers etc. are in place.
  4. Bearings have been lubricated, and alignment of rotating equipment has been checked.
  5. Equipment has been run under observation, and is operating in a satisfactory manner.
- B. Provide test and balance agency with one set of Contract Drawings, Specifications, Addenda, Change orders issued, applicable shop drawings and submittals and temperature control drawings.

3.17 CHECK, TEST AND START REQUIREMENTS

- A. An authorized representative of the equipment manufacturer shall perform check, test and start of each piece of plumbing equipment. The representative may be an employee of the equipment manufacturer, or a manufacturer-certified contractor. Submit written certification from the manufacturer stating that the representative is qualified to perform the check test and start of the equipment.
1. As part of the submittal process, provide a copy of each manufacturer’s printed startup form to be used.
  2. Some items of specified equipment may require that check, test and start of equipment must be performed by the manufacturer, using manufacturer’s employees. See specific equipment Articles in these Specifications for this requirement.
  3. Provide all personnel, test instruments, and equipment to properly perform the check, test and start work.
  4. When work has been completed, provide copies of reports for review, prior to final observation of work.
- B. Provide copies of the completed check, test and start report of each item of equipment, bound with the Operation and Maintenance Manual.

- C. Upon completion of the work, provide a schedule of planned maintenance for each piece of equipment. Indicate frequency of service, recommended spare parts (including filters and lubricants), and methods for adjustment and alignment of all equipment components. Provide a copy of the schedule with each operating and maintenance manual. Provide a copy of certification from the Owner's representative indicating that they have been properly instructed in maintenance requirements for the equipment installed.

### 3.18 PRELIMINARY OPERATIONAL REQUIREMENTS AND TESTS

- A. Prior to observation to determine final acceptance, put all mechanical systems into service and check that work required for that purpose has been done, including but not limited to the following condensed check list. Provide indexed report to tabulating the results of all work.
  - 1. All equipment has been started, checked, lubricated and adjusted in accordance with the manufacturer's recommendations.
  - 2. Correct rotation of motors and ratings of overload heaters are verified.
  - 3. Specified filters are installed and spare filters have been turned over to Owner.
  - 4. All manufacturers' certificates of start-up specified have been delivered to the Owner.
  - 5. All equipment has been cleaned, and damaged painted finishes touched up.
  - 6. Missing or damaged parts have been replaced.
  - 7. Flushing and chemical treatment of piping systems has been completed and water treatment equipment, where specified, is in operation.
  - 8. Equipment labels, pipe marker labels, ceiling markers and valve tags are installed.
  - 9. Valve tag schedules, corrected control diagrams, sequence of operation lists and start-stop instructions have been posted.
  - 10. Preliminary test and balance work is complete, and reports have been forwarded for review.
  - 11. Automatic control set points are as designated and performance of controls checks out to agree with the sequence of operation.
  - 12. Operation and Maintenance Manuals have been delivered and instructions to the operating personnel have been made.
- B. Prior to the observation to determine final acceptance, operate all mechanical systems as required to demonstrate that the installation and performance of these systems conform to the requirements of these specifications.
  - 1. Operate and test all mechanical equipment and systems for a period of at least five consecutive 8 hour days to demonstrate the satisfactory overall operation of the project as a complete unit.
  - 2. Commence tests after preliminary balancing and adjustments to equipment have been checked. Immediately before starting tests, install air filters and lubricate all running equipment. Notify the Architect at least seven calendar days in advance of starting the above tests.
  - 3. During the test period, make final adjustments and balancing of equipment, systems controls, and circuits so that all are placed in first class operating condition.
  - 4. Where Utility District rebates are applicable, demonstrate that the systems meet the rebate program requirements.
- C. Review of Contractor's Tests:
  - 1. All tests made by the Contractor or manufacturers' representatives are subject to observation and review by the Owner. Provide timely notice prior to start of each test, in order to allow for observation of testing. Upon the completion of all tests, provide a letter to confirm that all testing has been successful.

- D. Preliminary Operation:

1. The Owner reserves the right to operate portions of the plumbing system on a preliminary basis without voiding the guarantee.

### 3.19 CERTIFICATES OF INSTALLATION

- A. Contractor shall complete applicable "Certificates of Installation" forms contained in the California Building Energy Efficiency Standards and submit to the authorities having jurisdiction for approval and issuance of final occupancy permit, as described in the California Energy Code.

### 3.20 DEMONSTRATION AND TRAINING

- A. An authorized representative of the equipment manufacturer shall train Owner-designated personnel in maintenance and adjustment of equipment. The representative may be an employee of the equipment manufacturer, or a manufacturer-certified contractor. Submit written certification from the manufacturer stating that the representative is qualified to perform the Owner training for the equipment installed.
  1. As part of the submittal process, provide a training agenda outlining major topics and time allowed for each topic.
  2. Some items of specified equipment require that training must be performed by the manufacturer, using manufacturer's employees. See specific equipment Articles in these Specifications for this requirement.
  3. Contractor shall provide three copies of certification by Contractor that training has been completed, signed by Owner's representative, for inclusion in Operation and Maintenance Manual. Certificates shall include:
    - a. Listing of Owner-designated personnel completing training, by name and title.
    - b. Name and title of training instructor.
    - c. Date(s) of training.
    - d. List of topics covered in training sessions.
  4. Refer to specific equipment Articles for minimum training period duration for each piece of equipment.

**END OF SECTION 22 00 50**

## SECTION 22 40 00 - PLUMBING FIXTURES

### PART 1 - GENERAL

#### 1.1 SUMMARY

- A. Section Includes:
  - 1. Water supplies and stops.
  - 2. Plumbing fixture hangers and supports.
  - 3. Refrigerator ice maker outlet boxes.

#### 1.2 RELATED REQUIREMENTS

- A. Drawings and general provisions of the Contract, including General and Supplementary Conditions and Division 01 Specification Sections, apply to this Section.
- B. Section 22 00 50 Basic Plumbing Materials and Methods.

#### 1.3 QUALITY ASSURANCE

- A. For additional requirements, refer to Section 22 00 50, Basic Plumbing Materials and Methods.
- B. Plumbing Fixture Standards: Comply with applicable portions of the following codes and requirements for all work in this Section:
  - 1. California Building Code – CBC
  - 2. California Plumbing Code – CPC
  - 3. California Health and Safety Code
  - 4. American National Standards Institute - ANSI
  - 5. Federal Standards - F.S.
  - 6. National Sanitary Foundation – NSF International
- C. ANSI Standards: Comply with ANSI/NSF 61, "Drinking Water System Components – Health Effects."
- D. PDI Compliance: Comply with standards established by Plumbing and Drainage Institute pertaining to plumbing fixture supports.
- E. UL Labels: Provide water coolers that have been listed and labeled by Underwriters' Laboratories.
- F. ARI Labels: Provide water coolers that are rated and certified in accordance with applicable Air-Conditioning and Refrigeration Institute Standards.
- G. Americans with Disabilities Act (ADA).

#### 1.4 ACTION SUBMITTALS

- A. For additional requirements, refer to Section 22 00 50, Basic Plumbing Materials and Methods.
- B. Product Data: Submit manufacturer's specifications for plumbing fixtures and trim, including catalog cut of each fixture type and trim item furnished.



1.5 INFORMATIONAL SUBMITTALS

- A. Refer to Section 22 00 50, Basic Plumbing Materials and Methods.

1.6 CLOSEOUT SUBMITTALS

- A. For additional requirements, refer to Section 22 00 50, Basic Plumbing Materials and Methods.
- B. Maintenance Data: Submit maintenance data and parts lists for each fixture type and trim item, including instructions for care of finishes. Include this data in Operation and Maintenance Manual.

1.7 QUALITY ASSURANCE

- A. California Green Building Standards Code Requirements:

PART 2 - PRODUCTS

2.1 PLUMBING FIXTURES

- A. General: Provide factory fabricated fixtures of type, style and material indicated. For each type fixture, provide fixture manufacturer's standard trim, carrier, seats, and valves as indicated by their published product information; either as designed and constructed, or as recommended by the manufacturer, and as required for a complete, installation. Where more than one type is dedicated, selection is Contractor's option; but, all fixtures of same type must be furnished by single manufacturer.
  1. Take special care with the roughing-in and finished plumbing where batteries of fixtures occur.
  2. Take location and mounting heights for roughing-in from Architectural Drawings.
  3. Follow schedule on Plumbing Drawings for roughing-in connections. Set roughing-in for all fixtures exactly as per measurements furnished by the manufacturers of the fixtures used.
  4. Roughing-in for lavatories and sinks shall be brought in through the wall under the centerline of the drain from the fixture wherever possible and as close to the fixture as possible.

2.2 MATERIALS

- A. Provide materials that have been selected for their surface flatness and smoothness. Exposed surfaces that exhibit pitting, seam marks, roller marks, foundry sand holes, stains, discoloration, or other surface imperfections on finished units are not acceptable.
- B. Where fittings, trim and accessories are exposed or semi-exposed, provide, chromium plated 17 gauge seamless brass and match faucets and fittings. Provide 17 gauge seamless copper or brass where not exposed.
- C. Handles on all faucets and stops shall be all metal chromium plated.
- D. NSF Standard: Comply with NSF 61 and NSF 372 for supply-fitting materials that will be in contact with potable water.

## 2.3 PLUMBING FITTINGS, TRIM AND ACCESSORIES

- A. Water Outlets: At locations where water is supplied (by manual, automatic or remote control), provide commercial quality faucets, valves, or dispensing devices, of type and size indicated, and as required to operate as indicated.
  - 1. Include manual shutoff valves and connecting stem pipes to permit outlet servicing without shut-down of water supply piping systems.
- B. P-Traps: Include IAPMO approved removable P-traps where drains are indicated for direct connection to drainage system. P-Traps shall be less trap screw cleanout, and incorporate a chrome plated cast brass body, brass connection nuts, 17 gauge seamless brass wall return and chrome plated wall escutcheon to match trap finish.
- C. Carriers: Provide cast iron supports for fixtures of graphitic gray iron, ductile iron, or malleable iron as indicated. Where the carrier for wall mounted water closets are installed more than 6 inches behind the finished wall, provide water closet support for wide pipe chase.
- D. Fixture Bolt Caps: Provide manufacturer's standard exposed fixture bolt caps finished to match fixture finish.
- E. Escutcheons: Where fixture supplies and drains penetrate walls in exposed location, provide chrome-plated cast brass escutcheons with setscrews.
- F. Aerators: Provide aerators of types approved by Health Departments having jurisdiction. Delete aerators where not allowed by CPC for health care occupancies.
- G. Comply with additional fixture requirements contained in Fixture Schedule shown on the drawings.

## 2.4 MANUFACTURERS

- A. In accordance with California Plumbing Code, provide indelibly marked or embossed manufacturers name or logo, arranged so as to be visible after installation.
- B. Manufacturers: Drawing schedules indicate Basis of Design products. Subject to compliance with requirements, provide product indicated on Drawings, or comparable product by one of the following:
  - 1. Vitrified China Plumbing Fixtures:
    - a. American Standard, U.S. Plumbing Products.
    - b. Eljer Plumbingware Div., Wallace-Murray Corp.
    - c. Kohler Co.
    - d. VitrA.
  - 2. Plumbing Trim:
    - a. McGuire Manufacturing Co., Inc.
    - b. Delta Commercial.
    - c. Chicago Faucet Co.
    - d. T&S Brass and Bronze Works, Inc.
  - 3. Flush Valves:

- a. Sloan Valve Co.
  - b. Zurn Industries, Hydromechanics Div.
  - c. Toto USA, Inc.
4. Faucets:
- a. Chicago Faucet Co.
  - b. Symmons Scott.
  - c. T&S Brass and Bronze Works, Inc.
  - d. Delta Commercial.
5. Fixture Seats:
- a. Church Seat Co.
  - b. Bemis Mfg. Co.
  - c. Beneke Corp.
6. Water Coolers and Drinking Fountains:
- a. Haws Corporation.
  - b. Halsey Taylor Mfg. Co.
  - c. Elkay Mfg. Co.
  - d. Acorn Aqua.
7. Service Sinks:
- a. American Standard.
  - b. Kohler Co.
  - c. Williams Serviceceptor.
  - d. Florestone.
  - e. Acorn.
8. Stainless Steel Sinks:
- a. Elkay Mfg. Co.
  - b. Just Mfg. Co.
  - c. Haws Corporation.
9. Fixture Carriers:
- a. Josam Mfg. Co.
  - b. J. R. Smith.
  - c. Tyler Pipe; Wade Div.
  - d. Zurn Industries; Hydromechanics Div.
  - e. Mifab, Inc.

## 2.5 FLUSH VALVE REQUIREMENTS

- A. Metering flush valves where required and specified shall be non-hold open type with exposed parts chrome plated. Conform to all codes and manufacturers' recommendations. All diaphragms are to have multiple filtered bypass and be chloramine resistant synthetic rubber with internal components suitable for 180 degree hot water to 150 pounds pressure, plastic or leather diaphragm not acceptable.

## 2.6 FIXTURE CONNECTIONS

- A. Make connection between fixtures and flanges on soil pipe absolutely gastight and watertight with neoprene type gaskets (wall hung fixtures) or bowl wax (floor outlet fixtures). Rubber gaskets or putty will not be permitted.
- B. Provide fixtures not having integral traps with P-traps of chromium-plated 17 gauge cast brass, with 17 gauge seamless brass wall return, connected to concealed waste in wall and sanitary fittings. Provide IAPMO approval for trap, and provide less trap screw cleanout.
  - 1. Manufacturers: Subject to compliance with requirements, available manufacturers offering products that may be incorporated into the Work include the following, or equal:
    - a. Dearborn Brass, Commercial series with brass nuts.
    - b. Delta Commercial.
    - c. McGuire Manufacturing Co., Inc.
- C. Connections from stacks or horizontal wastes to wall or floor finish for wastes from lavatories, urinals, sinks, and drinking fountains and connection between floor drains and traps shall be IPS 85 percent red brass pipe.
- D. Unions on waste pipes on fixture side of traps may be slip or flange joints with soft rubber or lead gaskets. Traps shall rough in full size to waste and vent connection, using deep escutcheon plate to cover wall penetration. Compression adaptor extensions or sweat adaptors are not acceptable.

## 2.7 WATER SUPPLIES AND STOPS

- A. Provide 85 percent IPS threaded red brass nipple, conforming to the lead-free requirements of California Health and Safety Code Section 11 68 75, securely anchored to building construction, for each connection to stops, hose bibbs, etc. Each fixture, except hose bibbs, shall have stop valves installed on water supply lines.
- B. Provide water supplies to fixtures with compression shut-off stops with threaded inlets and lock shield-loose key handles. Provide combination fixtures with compression stop and threaded inlet on each water supply fitting. Provide lock shield-loose key handle for each stop.
- C. Provide 1/2 inch riser tubes with reducing coupling for fixtures, unless otherwise noted.
- D. Provide cast brass escutcheon.
- E. Furnish shut-off valves on hose bibbs where directly connected to mains with no intervening valves.
- F. Manufacturers: Subject to compliance with requirements, available manufacturers offering products that may be incorporated into the Work include the following, or equal:
  - 1. McGuire Manufacturing Company, Inc., model LFH2167LK.
  - 2. T & S Brass and Bronze Works, Inc., model B-1305.

## 2.8 PLUMBING FIXTURE HANGERS AND SUPPORTS

- A. Residential type fixture supports are not acceptable.

- B. Install wall mounted water closets with combination support and waste fittings, with feet of support securely anchored to floor.
- C. Install floor mounted water closets with J.R. Smith, Zurn, or equal government pattern cast iron closet flanges with brass bolts, nuts, washers, and porcelain caps secured with Spackle.
- D. Install the following fixtures on concealed support with feet of support securely anchored to floor. Anchor top of support to wall construction in an approved manner.
  - 1. Wall hung lavatories.
  - 2. Wall mounted urinals.
  - 3. Drinking fountains.
  - 4. Electric water coolers.

## 2.9 PLUMBING FIXTURES

- A. Install all plumbing fixtures at height indicated on Architectural Drawings. Where mounting height is not indicated, install at height required by Code.
- B. Special Requirements For Accessible Fixtures:
  - 1. Operating handle or valve for accessible water closets, urinals, lavatories, and sinks shall operate with less than 5 pounds force. Metering faucets shall be adjusted to operate between 10 and 15 seconds.
  - 2. Insulate exposed waste piping and domestic water supplies below accessible fixtures with CBC access code compliant molded "closed-cell" vinyl covers. Covers shall be installed using vandal resistant fasteners and must be removable. Covers shall meet flame spread rating not to exceed 25 and smoke density not to exceed 50 when tested in accordance with ASTM E-84, and shall comply with the requirements of California Code of Regulations, Title 24. Plumberex – Handy Shield, Johns Manville – Zeston 2000, or equal.
- C. Refrigerator Ice Maker Outlet Boxes:
  - 1. Manufacturers: Drawing schedules indicate Basis of Design products. Subject to compliance with requirements, provide product indicated on Drawings, or comparable product by one of the following, or equal:
  - 2. Guy Gray.
  - 3. Water-Tite.

## PART 3 - EXECUTION

### 3.1 PRODUCT HANDLING AND PROTECTION

- A. Deliver packaged materials in their original, unopened wrapping with labels intact. Protect materials from water, the elements and other damage during delivery, storage and handling.

### 3.2 PREPARATORY PROVISIONS

- A. The Contractor is responsible for the examination and acceptance of all conditions affecting the proper construction and/or installation of the Work of this Section. Do not proceed until all unsatisfactory conditions have been corrected. Commencing work will be construed as acceptance of all conditions by the Contractor as satisfactory for the construction and/or installation of the Work.

### 3.3 INSPECTION AND PREPARATION

- A. Examine roughing-in work of domestic water and waste piping systems to verify actual locations of piping connections prior to installing fixtures. Also examine floors and substrates, and conditions under which fixture work is to be accomplished. Correct any incorrect locations of piping, and other unsatisfactory conditions for installation of plumbing fixtures. Do not proceed with work until unsatisfactory conditions have been corrected.
- B. Install plumbing fixtures of types indicated where shown and at indicated heights; in accordance with fixture manufacturer's written instructions, roughing-in drawings. Ensure that plumbing fixtures comply with requirements and serve intended purposes. Comply with applicable requirements of the National Standard Plumbing Code pertaining to installation of plumbing fixtures.
- C. Fasten plumbing fixtures securely to supports or building structure; and ensure that fixtures are level and plumb. Secure plumbing supplies to blocking behind or within wall construction so as to be rigid, and not subject to pull or push movement.
- D. Install CBC accessible fixtures in accordance with Chapter 4 California Plumbing Code, and Chapters 11A and 11B California Building Code.

### 3.4 INSTALLATION OF FAUCETS

- A. Provide 85 percent IPS red brass pipe, conforming to lead-free requirements of California Health and Safety Code Section 11 68 75, securely anchored to building construction, for each connection to faucets, stops, hose bibbs, etc. Each fixture, except hose bibbs, shall have a stop valve installed on water supply lines to permit repairs without shutting off water mains.
- B. Adjust metering faucets to run for 10 to 15 seconds.

### 3.5 CLEAN AND PROTECT

- A. Clean plumbing fixtures of dirt and debris upon completion of installation.
- B. Protect installed fixtures from damage during the remainder of the construction period.
- C. Grout voids between all fixtures and adjacent surfaces with white Dow Silicone Sealant, arranged to shed water.

### 3.6 FIELD QUALITY CONTROL

- A. Upon completion of installation of plumbing fixtures and after units are water pressurized, test fixtures to demonstrate capability and compliance with requirements. When possible, correct malfunctioning units at site, then retest to demonstrate compliance; otherwise, remove and replace with new units and proceed with retesting.

### 3.7 EXTRA STOCK

- A. General: Furnish special wrenches and other devices necessary for servicing plumbing fixtures and trim to Owner with receipt. Furnish one device for every ten units.

**END OF SECTION 22 40 00**

## **SECTION 22 50 00 – PLUMBING EQUIPMENT**

### **PART 1 - GENERAL**

#### **1.1 SUMMARY**

##### **A. SECTION INCLUDES**

1. Expansion tanks.
2. In-line domestic hot water recirculation pumps.

#### **1.2 RELATED REQUIREMENTS**

- A. Drawings and general provisions of the Contract, including General and Supplementary Conditions and Division 01 Specification Sections, apply to this Section.
- B. Section 22 00 50 Basic Plumbing Materials and Methods.

#### **1.3 QUALITY ASSURANCE**

- A. For additional requirements, refer to Section 22 00 50, Basic Plumbing Materials and Methods.
- B. Trade names or catalog numbers stated herein indicates grade or quality of materials desired.
- C. Dimensions, sizes, and capacities shown are minimum and shall not be changed without permission of Architect.
- D. UL and NEMA Compliance: Provide electric motors and electrical components required as part of plumbing equipment, which have been listed and labeled by Underwriters Laboratories and comply with NEMA standards.
- E. CEC Compliance: Comply with California Electrical Code (Title 24, Part 3) as applicable to installation and electrical connections of ancillary electrical components of plumbing equipment.
- F. ASME Relief Valve Stamps: Provide water heaters with safety relief valves bearing ASME valve markings.
- G. California Energy Commission Compliance: Provide written confirmation of listing of all water heaters in the "Appliance Efficiency Database."

#### **1.4 ACTION SUBMITTALS**

- A. For additional requirements, refer to Section 22 00 50, Basic Plumbing Materials and Methods.
- B. Product Data: Submit manufacturer's plumbing equipment specifications, installation and start-up instructions, capacity and ratings, with selection points clearly indicated.

#### **1.5 INFORMATIONAL SUBMITTALS**

- A. For additional requirements, refer to Section 22 00 50, Basic Plumbing Materials and Methods.

#### **1.6 CLOSEOUT SUBMITTALS**

- A. For additional requirements, refer to Section 22 00 50, Basic Plumbing Materials and Methods.

- B. Maintenance Data: Submit maintenance data and parts lists for each item of plumbing equipment. Include "trouble-shooting" maintenance guides. Include this data in Operation and Maintenance Manual.

## PART 2 - PRODUCTS

### 2.1 MATERIALS

- A. NSF Compliance: Fabricate and label equipment components that will be in contact with potable water to comply with NSF 61 and NSF 372.
- B. Insulation products, including insulation, insulation facings, jackets, adhesives, sealants and coatings shall not contain polybrominated diphenyl ethers (PBDEs) in penta, octa, or deca formulations in amounts greater than 0.1 percent (by mass).

### 2.2 EXPANSION TANKS

- A. Provide thermal expansion tanks of size and number as indicated on Drawings, conforming to lead-free requirements of California Health and Safety Code Section 11 68 75. Construct tank of welded steel for working pressure of 125 psi. Provide specially compounded flexible diaphragm securely sealed into tank to permanently separate air charge from system water, to maintain design expansion capacity.

1. Tanks shall be IAPMO approved and listed for use with domestic water systems.

- B. Manufacturers: Subject to compliance with requirements, available manufacturers offering products that may be incorporated into the Work include the following, or equal:

1. Amtrol, Inc.
2. A.O. Smith Water Products Company.
3. Watts Water Technologies, Inc.

### 2.3 IN-LINE DOMESTIC HOT WATER RECIRCULATION PUMPS

- A. Provide lead-free in-line domestic water recirculation pumps where indicated on Drawings and of capacities as scheduled on Drawings. Pumps shall be third-party certified by an approved laboratory as complying with California Health and Safety Code Section 11 68 75.
- B. Pumps shall be of the centrifugal type with non-overloading characteristics and shall not overload the motor above its nameplate horsepower rating under any operating condition. No allowance for service factor shall be used in pump selection. Motor horsepower shown is minimum; furnish larger motors if necessary to meet the non-overloading requirements.
- C. Type: Horizontal, designed for 125 thru 150 psi maximum working pressure and 225 degrees F continuous water temperature.
- D. Construction: Bronze casing, non-metallic impeller.
- E. Shaft: Ceramic, supported by carbon bearings. Bearings shall be lubricated by the pumped water.
- F. Motors shall have permanently lubricated ball bearings. Motors shall meet NEMA specifications. Motors shall have built-in thermal overload or impedance protection.



- G. Provide control wiring between field-installed controls, indicating devices, and pump control panels as work of this section, complying with requirements of Division 26 sections:
  - 1. Control wiring specified as work of Division 23 for Automatic Temperature Controls is work of that section.
- H. Wire pumps to mechanical control circuits to shut down pump when building is not occupied. Where no control system is installed, furnish pump manufacturers standard timer to automatically turn off circulating pump when hot water is not required.
- I. Manufacturers: Subject to compliance with requirements, available manufacturers offering products that may be incorporated into the Work include the following, or equal:
  - 1. Grundfos Pumps Corporation.
  - 2. Bell & Gossett, ITT Corporation.
  - 3. Taco Incorporated.
  - 4. Armstrong Pumps, Inc.

### PART 3 - EXECUTION

#### 3.1 PRODUCT HANDLING AND PROTECTION

- A. Deliver packaged materials in their original, unopened wrapping with labels intact. Protect materials from water, the elements and other damage during delivery, storage and handling.

#### 3.2 PREPARATORY PROVISIONS

- A. The Contractor shall be responsible for the examination and acceptance of all conditions affecting the proper construction and/or installation of the Work of this Section and shall not proceed until all unsatisfactory conditions have been corrected. Commencing work shall be construed as acceptance of all conditions by the Contractor as satisfactory for the construction and/or installation of the Work.

#### 3.3 INSTALLATION OF PUMPS

- A. Install pumps where indicated, in accordance with manufacturer's published instructions, complying with recognized industry practices to ensure that pumps comply with requirements and serve intended purposes.
- B. Provide access space around pumps for service as indicated, but in no case less than that recommended by manufacturer.
- C. Install in-line pumps with support from overhead structure on each side of pump, or as indicated on Drawings.
- D. Support piping from the building structure so as to prevent any strain on the pump casings. Provide a final check for perfect alignment of the piping connections after pump has been secured to its base. Provide valves, accessories, gauges, flexible connections, and supports as indicated.
- E. Install electrical devices furnished by manufacturer but not specified to be factory mounted. Furnish copy of manufacturer's wiring diagram submittal to Electrical Installer.

- F. Verify that electrical wiring installation is in accordance with manufacturer's submittal and installation requirements of Division 26 sections. Do not proceed with equipment start-up until wiring installation is complete and correct.
- G. Check alignment, and where necessary, realign shafts of motors and pumps within recommended tolerances by manufacturer.
- H. Lubricate pumps before start-up. Start-up in accordance with manufacturer's instructions.
- I. Increase piping immediately at pump suction and discharge; flexible couplings and all valves shall be full line size.
- J. Trim pump impeller to obtain the desired water flow after installation, without cost to Owner.
- K. Pumps shall not be connected to piping before piping is thoroughly flushed and cleaned of all dirt and grit. After piping connections have been made, systems shall be filled before starting pumps. Pumps shall not be run dry under any circumstances.

#### 3.4 TRAINING

- A. Provide a minimum of (4) hours of training and orientation of Owners staff in proper care and operation of Plumbing Equipment.

#### 3.5 CARE AND CLEANING

- A. Repair or replace broken, damaged, or otherwise defective parts, materials, and work. Leave entire work in condition satisfactory to Architect. At completion, carefully clean and adjust equipment, fixtures, and trim that are installed as part of this work. Leave systems and equipment in satisfactory operating condition.

#### 3.6 OPERATION TEST

- A. Test each piece of equipment to show that it will operate in accordance with indicated requirements.

#### 3.7 CLEANING UP

- A. Upon completion of Work remove materials, equipment, apparatus, tools, and the like, and leave premises clean, neat, and orderly.

**END OF SECTION 22 50 00**

## **SECTION 23 00 50 - BASIC HVAC MATERIALS AND METHODS**

### **PART 1 - GENERAL**

#### **1.1 SUMMARY**

**A. Section Includes:**

1. Electric motors.
2. Motor starters.
3. Access Doors.
4. Insulation.

#### **1.2 RELATED REQUIREMENTS**

- A.** Drawings and general provisions of the Contract, including General and Supplementary Conditions and Division 01 Specification Sections, apply to this Section.
- B.** This Section is a part of each Division 23 Section.

#### **1.3 ADDITIONAL REQUIREMENTS**

- A.** Furnish and install incidental work not shown or specified necessary to provide a complete and workable system.
- B.** Make all temporary connections required to maintain services, including adequate heat and cooling, during the course of the Contract without additional cost to Owner. Notify Owner seven days in advance before disrupting services.
- C.** Provide for adjustments or modifications to fan and motor sheaves, belts, damper linkages, and other components as required to achieve specified air balance at no additional cost to Owner.

#### **1.4 REFERENCES AND STANDARDS**

- A.** Where material or equipment is specified to conform to referenced standards, it shall be assumed that the most recent edition of the standard in effect at the time of bid shall be used.
1. AABC - Associated Air Balance Council
  2. AFBMA - Anti Friction Bearing Manufacturer's Association
  3. AMCA - Air Moving and Control Association Inc.
    - a. Standard 210 - Laboratory Methods of Testing Fans
  4. ANSI - American National Standards Institute
  5. ARI - Air-Conditioning and Refrigeration Institute
  6. ASHRAE - American Society of Heating, Refrigerating and Air Conditioning Engineers
  7. ASME - American Society of Mechanical Engineers
  8. ASTM - American Society for Testing and Materials
  9. CCR - California Code of Regulations
    - a. Title 8 - Division of Industrial Safety, Subchapter 7; General Industry Safety Orders, Articles 31 through 36
  10. CSA – Canadian Standards Association International

11. CSFM - California State Fire Marshal
12. NCPWB - National Certified Pipe Welding Bureau
13. NIST - National Institute of Standards and Technology
14. NEMA - National Electrical Manufacturers' Association
15. NFPA - National Fire Protection Association
16. OSHA - Occupational Safety and Health Act
17. SMACNA - Duct Manuals
18. UL - Underwriters' Laboratories, Inc.

B. Requirements of Regulatory Agencies:

1. The publications listed below form part of this specification; comply with provisions of these publications except as otherwise shown or specified.
  - a. California Building Code, 2016.
  - b. California Electrical Code, 2016.
  - c. California Energy Code, 2016.
  - d. California Fire Code, 2016.
  - e. California Green Building Standards Code, 2016.
  - f. California Mechanical Code, 2016.
  - g. California Plumbing Code, 2016.
  - h. California Code of Regulations, Title 24.
  - i. California Health and Safety Code.
  - j. CAL-OSHA.
  - k. California State Fire Marshal, Title 19 CCR.
  - l. National Fire Protection Association.
  - m. Occupational Safety and Health Administration.
  - n. Other applicable state laws.
2. Nothing in Drawings or specifications shall be construed to permit work not conforming to these codes, or to requirements of authorities having jurisdiction. It is not the intent of Drawings or specifications to repeat requirements of codes except where necessary for clarity.

1.5 DRAWINGS

- A. Examine Drawings prior to bidding of work and report discrepancies in writing to Architect.
- B. Drawings showing location of equipment and materials are diagrammatic and job conditions will not always permit installation in location shown. The HVAC Drawings show general arrangement of equipment and materials, etc., and shall be followed as closely as existing conditions, actual building construction, and work of other trades permit.
  1. Architectural and Structural Drawings shall be considered part of the Work. These Drawings furnish Contractor with information relating to design and construction of the Project. Architectural Drawings take precedence over HVAC Drawings.
  2. Because of the small scale of HVAC Drawings, not all offsets, fittings, and accessories required are shown. Investigate structural and finish conditions affecting the Work and arrange Work accordingly. Provide offsets, fittings, and accessories required to meet conditions. Inform Architect immediately when job conditions do not permit installation of equipment and materials in the locations shown. Obtain the Architects approval prior to relocation of equipment and materials.
  3. Relocate equipment and materials installed without prior approval of the Architect. Remove and relocate equipment and materials at Contactors' expense upon Architects' direction.

4. Minor changes in locations of equipment, piping, ducts, etc., from locations shown shall be made when directed by the Architect at no additional cost to the Owner providing such change is ordered before such items of work, or work directly connected to same are installed and providing no additional material is required.
- C. Execute work mentioned in the Specifications and not shown on the Drawings, or vice versa, the same as if specifically mentioned or shown in both.
- 1.6 FEES AND PERMITS
- A. Obtain and coordinate payment by Owner for permits and service required in installation of the Work. Arrange for required inspections and secure approvals from authorities having jurisdiction. Comply with requirements of Division 01.
- 1.7 Coordination:
- A. General:
1. Coordinate HVAC Work with trades covered in other Specifications Sections to provide a complete, operable and sanitary installation of the highest quality workmanship.
- B. Electrical Coordination:
1. Refer to the Electrical Drawings and Specifications, Division 26, for service voltage and power feed wiring for equipment specified under this section. Contractor has full responsibility for the following items of work:
  2. Review the Electrical Drawings and Division 26 Specifications to verify that electrical services provided are adequate and compatible with equipment requirements.
  3. If additional electrical services are required above that indicated on Electrical Drawings and in Division 26, such as more control interlock conductors, larger feeder, or separate 120 volt control power source, include cost to furnish and install additional electrical services as part of the bid.
  4. Prior to proceeding with installation of additional electrical work, submit detailed drawings indicating exact scope of additional electrical work.
- C. Mechanical Coordination:
1. Arrange for pipe spaces, chases, slots and openings in building structure during progress of construction, to accommodate mechanical system installation.
  2. Coordinate installation of supporting devices. Set sleeves in poured-in-place concrete and other structural components during construction.
  3. Coordinate requirements for access panels and doors for mechanical items requiring access where concealed behind finished surfaces. Access panels and doors are specified in Division 08 Section "Access Doors and Frames."
  4. Coordinate with other trades equipment locations, pipe, duct and conduit runs, electrical outlets and fixtures, air inlets and outlets, and structural and architectural features. Provide information on location of piping and seismic bracing to other trades as required for a completely coordinated project.
- 1.8 SUBMITTALS - GENERAL
- A. Submittal packages may be submitted via email as PDF electronic files, or as printed packages. PDFs shall be legible at actual size (100 percent). Provide seven copies of printed submittal packages.

- B. Provide submittal of materials proposed for use as part of this Project. Product names in Specifications and on Drawings are used as standards of quality. Furnish standard items on specified equipment at no extra cost to the Contract regardless of disposition of submittal data. Other materials or methods shall not be used unless approved in writing by Architect. Architect's review will be required even though "or equal" or synonymous terms are used. Refer to Division 01 for complete instructions.
1. Partial or incomplete submittals will not be considered.
  2. Quantities are Contractor's responsibility and will not be reviewed.
  3. Provide materials of the same brand or manufacturer for each class of equipment or material.
  4. Identify each item by manufacturer, brand, trade name, number, size, rating, or other data necessary to properly identify and review materials and equipment. Words "as specified" are not sufficient identification.
  5. Identify each submittal item by reference to items' Specification Section number and paragraph, by Drawing and detail number, and by unit tag number.
  6. Organize submittals in same sequence as in Specification Sections.
  7. Show physical arrangement, construction details, finishes, materials used in fabrications, provisions for piping entrance, access requirements for installation and maintenance, physical size, mechanical characteristics, foundation and support details, and weight.
    - a. Submit Shop Drawings, performance curves, and other pertinent data, showing size and capacity of proposed materials.
    - b. Specifically indicate, by drawn detail or note, that equipment complies with each specifically stated requirement of Contract Documents.
    - c. Drawings shall be drawn to scale and dimensioned (except schematic diagrams). Drawings may be prepared by vendor but must be submitted as instruments of Contractor, thoroughly checked and signed by Contractor before submission to Architect for review.
    - d. Catalog cuts and published material may be included with supplemental scaled drawings.
- C. Review of submittals will be only for general conformance with design concept and general compliance with information given in Contract Documents. Review will not include quantities, dimensions, weights or gauges, fabrication processes, construction methods, coordination with work of other trades, or construction safety precautions, which are sole responsibility of Contractor. Review of a component of an assembly does not indicate acceptance of an assembly. Deviations from Contract Documents not clearly identified by Contractor are Contractor's responsibility and will not be reviewed by Architect.
- D. Within reasonable time after award of contract and in ample time to avoid delay of construction, submit to Architect shop drawings or submittals on all items of equipment and materials provided. Provide submittal as a complete package.
1. Shop drawings and submittals shall include Specification Section, Paragraph number, and Drawing unit symbol or detail number for reference. Organize submittals into booklets for each Specification section and submit in loose-leaf binders with index. Deviations from the Contract Documents shall be prominently displayed in the front of the submittal package and referenced to the applicable Contract requirement.
- E. Furnish to the Project Inspector complete installation instructions on material and equipment before starting installation.

## 1.9 ACTION SUBMITTALS

- A. Product Data: Submit manufacturer's technical product data and installation instructions for plumbing systems materials and products.
- B. Shop Drawings.
- C. Provide product data for insulation products, including insulation, insulation facings, jackets, adhesives, sealants, and coatings, indicating compliance with requirement that these products contain less than 0.1 percent (by mass) polybrominated diphenyl ethers (PBDEs) in penta, octa, or deca formulations.

## 1.10 INFORMATIONAL SUBMITTALS

- A. Provide coordinated layouts for HVAC Ductwork systems, in accordance with Specification Section 23 80 00.
- B. Provide evidence of equipment certification to California Energy Code Section 110.1 or 110.2, if not providing Electrically Commutated motors for HVAC fans sized below 1 hp and above 1/12 hp. Refer to specific equipment articles requiring electrically commutated motors.

## 1.11 CLOSEOUT SUBMITTALS

- A. Operation and Maintenance Data:
  - 1. Provide Closeout Submittal Operating and Maintenance documents in accordance with Division 01.
  - 2. Post service telephone numbers and addresses in an appropriate place designated by Architect.
- B. Record Drawings:
  - 1. Refer to Division 01 for additional requirements.
  - 2. Upon completion of the Work, deliver to Architect the following:
    - a. Originals of drawings showing the Work exactly as installed.
    - b. One complete set of reproducible drawings showing the Work exactly as installed.
    - c. One compact disc with complete set of drawings in PDF format showing the Work exactly as installed.
    - d. Provide Contractor's signature, verifying accuracy of record drawings.
    - e. Obtain the signature of the Inspector of Record for Record Drawings.

## 1.12 SUBSTITUTIONS

- A. Refer to Division 01 for complete instructions.

## 1.13 QUALITY ASSURANCE

- A. Manufacturer's Qualifications: Firms regularly engaged in manufacture of HVAC systems products, of types, materials, and sizes required, whose products have been in satisfactory use in similar service for not less than 5 years.
- B. Contractor's Qualifications: Firm with at least 5 years of successful installation experience on projects with HVAC systems work similar to that required for this Project.

- C. Comply with applicable portions of California Mechanical Code pertaining to selection and installation of HVAC materials and products.
- D. All materials and products shall be new.

#### 1.14 DELIVERY, STORAGE, AND HANDLING

- A. Protect equipment and materials delivered to Project site from weather, humidity and temperature variations, dirt, dust and other contaminants.

#### 1.15 FIELD CONDITIONS

- A. Contractor shall visit Project site and examine existing conditions in order to become familiar with Project scope. Verify dimensions shown on Drawings at Project site. Bring discrepancies to the attention of Architect. Failure to examine Project site shall not constitute basis for claims for additional work because of lack of knowledge or location of hidden conditions that affect Project scope.
- B. Information on Drawings relative to existing conditions is approximate. Deviations from Drawings necessary during progress of construction to conform to actual conditions shall be approved by the Architect and shall be made without additional cost to the Owner. The Contractor shall be held responsible for damage caused to existing services. Promptly notify the Architect if services are found which are not shown on Drawings.

#### 1.16 WARRANTY

- A. Refer to Division 01 for warranty requirements, including effective date of warranty. Refer to specific items of equipment specified herein for warranty duration if different from that specified in Division 01.
- B. Repair or replace defective work, material, or part that appears within the warranty period, including damage caused by leaks.
- C. On failure to comply with warranty requirements within a reasonable length of time after notification is given, Architect/Owner shall have repairs made at Contractor's expense.

### PART 2 - PRODUCTS

#### 2.1 GENERAL

- A. Materials or equipment of the same type shall be of the same brand wherever possible. All materials shall be new and in first class condition.
- B. All sizes, capacities, and efficiency ratings shown are minimum, except that gas capacity is maximum available.
- C. Refer to Division 22 10 00 and 23 80 00 for specific system piping materials.

#### 2.2 MATERIALS

- A. No material installed as part of this Work shall contain asbestos.
- B. Insulation products, including insulation, insulation facings, jackets, adhesives, sealants and coatings shall not contain polybrominated diphenyl ethers (PBDEs) in penta, octa, or deca formulations in amounts greater than 0.1 percent (by mass).



- C. California Green Building Code Compliance:
  - 1. HVAC and refrigeration equipment shall not contain CFCs.
  - 2. HVAC and refrigeration equipment shall not contain Halons.

## 2.3 ELECTRIC MOTORS

- A. General Motor Requirements: Comply with NEMA MG 1 unless otherwise indicated. Comply with IEEE 841 for severe-duty motors.
  - 1. Manufacturers: Subject to compliance with requirements, available manufacturers offering products that may be incorporated into the Work include the following, or equal:
    - a. U.S. Motors.
    - b. Century Electric.
    - c. General Electric.
    - d. Lincoln.
    - e. Gould.
- B. Motor Characteristics: Designed for continuous duty at ambient temperature of 40 deg. C and at altitude of 3300 feet above sea level. Capacity and torque shall be sufficient to start, accelerate, and operate connected loads at designated speeds, at installed altitude and environment, with indicated operating sequence, and without exceeding nameplate ratings or considering service factor.
  - 1. Motors exceeding the nameplate amperage shall be promptly replaced at no cost to the Owner. Horsepower shown is minimum and shall be increased as necessary to comply with above requirements. Furnish motors with splash-proof or weatherproof housings, where required or recommended by the manufacturer. Match the nameplate voltage rating with the electrical service supplied. Check Electrical Drawings. Provide a transformer for each motor not wound specifically for system voltage.
- C. Polyphase Motors: NEMA MG 1, Design B, medium induction motor, premium efficiency as defined in NEMA MG 1. Select motors with service factor of 1.15. Provide motor with random-wound, squirrel cage rotor, and permanently lubricated or regreasable, shielded, antifriction ball bearings suitable for radial and thrust loading. Temperature rise shall match insulation rating. Provide Class F insulation.
  - 1. Multispeed motors shall have separate windings for each speed.
- D. Polyphase Motors with Additional Requirements:
  - 1. Motors Used with Reduced-Voltage and Multispeed Controllers: Match wiring connection requirements for controller with required motor leads. Provide terminals in motor terminal box, suited to control method.
  - 2. Motors Used with Variable Frequency Controllers:
    - a. Separately Connected Motors: Ratings, characteristics, and features coordinated with and approved by controller manufacturer.
    - b. Windings: Copper magnet wire with moisture-resistant insulation varnish, designed and tested to resist transient spikes, high frequencies, and short time rise pulses produced by pulse-width modulated inverters.
    - c. Premium-Efficient Motors: Class B temperature rise; Class F insulation.
    - d. Inverter-Duty Motors: Class F temperature rise; Class H insulation.

- e. Thermal Protection: Comply with NEMA MG 1 requirements for thermally protected motors.
  - f. Each motor shall be provided with a shaft grounding device for stray current protection.
3. Severe-Duty Motors: Comply with IEEE 841, with 1.15 minimum service factor.
- E. Single-Phase Motors:
- 1. Select motors with service factor of 1.15.
  - 2. Motors larger than 1/20 hp shall be one of the following, to suit starting torque and requirements of specific motor application:
    - a. Permanent-split capacitor.
    - b. Split phase.
    - c. Capacitor start, inductor run.
    - d. Capacitor start, capacitor run.
  - 3. Motors for HVAC exhaust, transfer, and supply fans larger than 1/12 hp and smaller than 1 hp shall be the following:
    - a. Electronically Commutated motor (EC type): Motor shall be electronically commutated type specifically designed for applications, with heavy duty ball bearings. The motor shall be speed controllable down to 20% of full speed and 85% efficient at all speeds.
    - b. Exceptions:
      - a) Motors in fan-coils and terminal units that operate only when providing heating to the space served.
      - b) Motors installed in space conditioning equipment certified under 2013 California Energy Code Section 110.1 or 110.2.
  - 4. Contractor's Option: Motors scheduled on Drawings as single-phase, and larger than 1/12 hp and smaller than 1 hp, for applications other than HVAC fans, may be EC type.
  - 5. Multispeed Motors: Variable-torque, permanent-split-capacitor type.
  - 6. Bearings: Prelubricated, antifriction ball bearings or sleeve bearings suitable for radial and thrust loading.
  - 7. Motors 1/20 HP and Smaller: Shaded-pole type.
  - 8. Thermal Protection: Internal protection to automatically open power supply circuit to motor when winding temperature exceeds a safe value calibrated to temperature rating of motor insulation. Thermal-protection device shall automatically reset when motor temperature returns to normal range.

## 2.4 MOTOR STARTERS

- A. Square D, Allen Bradley, or equal, in NEMA Type 1 enclosure, unless otherwise specified or required. Minimum starter size shall be Size 1. Provide NEMA 3R enclosure where exposed to outdoors.
- B. Provide magnetic motor starters for all equipment provided under the Mechanical Work. Starters shall be non-combination type. Provide part winding or reduced voltage start motors where shown or as hereinafter specified. Minimum size starter shall be Size 1.
  - 1. All starters shall have the following:

- a. Cover mounted hand-off-automatic switch. Starters installed exposed in occupied spaces shall have key operated HOA switch.
  - b. Ambient compensated thermal overload.
  - c. Fused control transformer (for 120 or 24 volt service).
  - d. Pilot lights, integral with the starters. Starters located outdoors shall be in NEMA IIIR enclosures.
- 2. Where three phase motors are provided for two-speed operation, provide two speed motor starters.
  - 3. Starters for single-phase motors shall have thermal overloads. NEMA I enclosure for starters located indoors, NEMA IIIR enclosure for starters located outdoors.
  - 4. Provide OSHA label indicating the device starts automatically.

## 2.5 ACCESS DOORS

- A. Where floors, walls, or ceilings must be penetrated for access to mechanical equipment, provide access doors, 14 inch by 14 inch minimum size in usable opening. Where entrance of a serviceman may be required, provide 20 inch by 30 inch minimum usable opening. Locate access doors/panels for non-obstructed and easy reach.
  - 1. All access doors less than 7'-0" above floors and exposed to public access shall have keyed locks.
- B. Access doors shall match those supplied in Division 08 in all respects, except as noted herein.
- C. Provide stainless steel access doors for use in toilet rooms, shower rooms, kitchens and other damp areas. Provide steel access doors with prime coat of baked-on paint for all other areas.
- D. Where panels are located on ducts or plenums, provide neoprene gaskets to prevent air leakage, and use frames to set door out to flush with insulation.
- E. Provide insulated doors where located in internally insulated ducts or casings.
- F. Do not locate access doors in highly visible public areas such as lobbies, waiting areas, and primary entrance areas. Coordinate with the Architect when access is required in these areas.
- G. Where specific information or details relating to access panels different from the above is shown or given on the Drawings or other Divisions of work, then that information shall supersede this specification.
- H. Manufacturers: Subject to compliance with requirements, available manufacturers offering products which may be incorporated into the Work include Milcor, Karp, Nystrom, or Cesco, equal to the following:
  - 1. Milcor
    - a. Style K (plaster).
    - b. Style DW (gypsum board).
    - c. Style M (Masonry).
    - d. Style "Fire Rated" where required.

## 2.6 EQUIPMENT IDENTIFICATION

- A. Identify each piece of equipment with a permanently attached engraved bakelite plate, 1/2 inch high white letters on black background.

## 2.7 PIPE IDENTIFICATION

- A. Identify each piping system and indicate the direction of flow by means of Seton, Inc., Marking Services Inc., Reef Industries, Inc., or equal, pre-tensioned, coiled semi-rigid plastic pipe labels formed to circumference of pipe, requiring no fasteners or adhesive for attachment to pipe.
- B. The legend and flow arrow shall conform to ASME A13.1.

## 2.8 INSULATION WORK

### A. General:

1. Insulation products, including insulation, insulation facings, jackets, adhesives, sealants and coatings shall not contain polybrominated diphenyl ethers (PBDEs) in penta, octa, or deca formulations in amounts greater than 0.1 percent (by mass).
2. Adhesives and sealants shall comply with testing and product requirements of South Coast Air Quality Management District, Rule 1168.
3. The term "piping" used herein includes pipe, air separators, valves, strainers and fittings.
4. Apply insulating cement to fittings, valves and strainers and trowel smooth to the thickness of adjacent covering. Cover with jacket to match piping. Extend covering on valves up to the bonnet. Leave strainer cleanout plugs accessible.
5. Provide pre-formed PVC valve and fitting covers for indoor piping.
6. Provide factory-fabricated aluminum valve and fitting covers for outdoor piping.
7. Provide Calcium Silicate rigid insulation and sheet metal sleeve, 18 inch minimum length at each pipe hanger. Seal ends of insulation to make vapor tight with jacket.
8. Test insulation, jackets, and lap-seal adhesives as a composite product and confirm flame spread of not more than 25 and a smoke developed rating of not more than 50 when tested in accordance with UL723, ASTM E84, or NFPA 255.
9. Clean thoroughly, test and have approved, all piping and equipment before installing insulation and/or covering.
10. Repair all damage to existing pipe and duct insulation whether or not caused during the work of this contract, to match existing adjacent insulation for thickness and finish, but conforming to flame spread and smoke ratings specified above.

### B. Insulation of Piping:

1. Exposed insulated piping within the building shall have a Zeston 2000 25/50, Proto Lo-Smoke, or equal, PVC jacket and fitting cover installed over the insulation, applied per manufacturer's instructions. Insulation shall be vapor tight before applying PVC jacket and fitting covers. Verify suitability with manufacturer of insulation. Insulation with pre-applied polymer jacket may be substituted at Contractor's option.
2. Insulate refrigerant suction piping and chilled water supply and return piping, including fittings, with minimum 3-1/2 pounds per cubic foot density fiberglass with factory-applied ASJ-SSL jacket. Insulate valves and irregular surfaces to match adjacent insulation and cover with two layers of Glasfab saturated in Foster's Sealfas 30-36, 3M, or equal, carried 3 inches over the adjoining pipe insulation. Finish with a coat of Foster's Sealfas 30-36, 3M, or equal. The 3 inch wide SSL end laps furnished with the insulation shall be adhered over the end joints. Seal entire surface of insulation vapor tight, including joints and ends of PVC or aluminum fitting covers. Insulation thicknesses per application follow:
  - a. Indoor refrigerant suction piping 3/4 inch diameter and smaller: 1 inch thick.
  - b. Indoor refrigerant suction piping 1 inch diameter and larger: 1-1/2 inches thick.
  - c. Outdoor refrigerant suction piping; all sizes: 2 inches thick.

3. In lieu of the above, refrigerant suction piping, including fittings, may be insulated with Armacell LLC; AP Armaflex, or equal. Seal all joints with Armaflex 520 BLV adhesive, or equal. Apply insulation in strict accordance with manufacturer's recommendations. Insulation thicknesses follow:
  - a. Indoor refrigerant suction piping 3/4 inch diameter and smaller: 1/2 inch thick.
  - b. Indoor refrigerant piping 1 inch diameter and larger: 1 inch thick.
  - c. Outdoor refrigerant piping; all sizes: 2 inches thick.
4. When equipment manufacturers' instructions indicate that refrigerant liquid and hot-gas gas piping be insulated, insulation thickness shall be equal to, and applied as described herein for refrigerant suction piping.
5. Variable refrigerant flow (VRF) heat pump systems: Insulation for VRF system refrigerant piping shall be installed according to VRF unit manufacturer's instructions.
6. Where insulated piping is exposed to the weather apply aluminum jacket secured with 1/2 inch stainless-steel bands on 12 inch centers. Insulation shall be vapor tight before applying metal jacket, and aluminum fitting covers. Install jacketing with 2-inch overlap at longitudinal seams and end joints. Overlap longitudinal seams arranged to shed water. Seal end joints with weatherproof sealant recommended by insulation manufacturer. Cover fittings with glass cloth, two coats of Foster Sealfas 30-36, and factory-fabricated aluminum fitting covers, of same material, finish, and thickness as jacket. Insulation shall be vapor tight before applying metal jacket and fitting covers.
  - a. Preformed 2-piece or gore, 45- and 90-degree, short- and long-radius elbows.
  - b. Tee covers.
  - c. Flange and union covers.
  - d. End caps.
  - e. Beveled collars.
  - f. Valve covers.
  - g. Field fabricate fitting covers only if factory-fabricated fitting covers are not available.
7. Jacket thickness:
  - a. Pipes 10 inches diameter and smaller: Minimum .016 inch thick jacket with smooth finish.
  - b. Pipes 12 inches diameter and larger: Minimum .020 inch thick jacket with smooth finish.

C. Duct Insulation:

1. Ductwork installed within the building insulation envelope, duct insulation shall have a minimum R-value of R-4.2 at 2 inch thickness, 3/4 pound per cubic foot density.
2. General: Insulation applied to the exterior surface of ducts located in buildings shall have a flame spread of not more than 25 and a smoke-developed rating of not more than 50 when tested as a composite installation including insulation, facing materials, tapes and adhesives as normally applied. Material exposed within ducts or plenum shall have a flame-spread rating of not more than 25 and a smoke-developed rating of not more than 50.
3. Fibrous Glass Blanket Insulation:
  - a. Insulate all unlined concealed supply and return ducts with fiberglass duct wrap, manufactured as a blanket of glass fibers factory laminated to a reinforced foil/kraft vapor retarding facing. Provide 2 inch stapling and taping flange. Wrap insulation entirely around duct and secure with outward clinching staples on 6 inch centers. Provide mechanical fasteners at maximum 18 inch centers for all bottoms of duct which are greater than 24 inches. Lap all insulation joints 3" minimum. Insulate

ducts installed tight against other work before hanging in place. Seal all seams, both longitudinal and transverse, and all staple and mechanical fastener penetrations of facing with scrim backed foil tape or recommended sealant, to provide a vapor tight installation.

4. Fibrous Glass Board Insulation:
  - a. Mineral or glass fibers bonded with a thermosetting resin. Comply with ASTM C 612, Type IA or Type IB. For duct and plenum applications, provide insulation with factory-applied FSK jacket.
5. Provide internal duct lining in accordance with specification section 23 80 00.

### PART 3 - EXECUTION

#### 3.1 EXISTING MATERIALS:

- A. Remove existing equipment, piping, wiring, construction, etc., which interferes with Work of this Contract. Promptly return to service upon completion of work in the area. Replace items damaged by Contractor with new material to match existing.
- B. Removed materials which will not be re-installed and which are not claimed by Owner shall become the property of Contractor and shall be removed from the Project site. Consult Owner before removing any material from the Project site. Carefully remove materials claimed by Owner to prevent damage and deliver to Owner-designated storage location.
- C. Existing piping and wiring not reused and are concealed in building construction may be abandoned in place and all ends shall be capped or plugged. Remove unused piping and wiring exposed in Equipment Rooms or occupied spaces. Material shall be removed from the premises. Disconnect power, water, gas, pump or any other active energy source from piping or electrical service prior to abandoning in place.

#### 3.2 FRAMING, CUTTING AND PATCHING

- A. Special framing, recesses, chases and backing for Work of this Section, unless otherwise specified, are covered under other Specification Sections.
- B. Contractor is responsible for placement of pipe sleeves, hangers, inserts, supports, and location of openings for the Work.
- C. Cutting, patching, and repairing of existing construction to permit installation of equipment, and materials is the responsibility of Contractor. Repair or replace damage to existing work with skilled mechanics for each trade.
- D. Cut existing concrete construction with a concrete saw. Do not utilize pneumatic devices.
- E. Core openings through existing construction for passage of new piping and conduits. Cut holes of minimum diameter to suit size of pipe and associated insulation installed. Coordinate with building structure, and obtain Structural Engineer's approval prior to coring through existing construction.

#### 3.3 MECHANICAL DEMOLITION

- A. Refer to Division 01 Sections "Cutting and Patching" and "Selective Demolition" for general demolition requirements and procedures.

- B. If pipe, insulation, or equipment to remain is damaged in appearance or is unserviceable, remove damaged or unserviceable portions and replace with new products of equal capacity and quality.

### 3.4 ELECTRICAL REQUIREMENTS

- A. Provide adequate working space around electrical equipment in compliance with the California Electrical Code. Coordinate the Mechanical Work with the Electrical Work to comply.
- B. Furnish necessary control diagrams and instructions for the controls. Before permitting operation of any equipment which is furnished, installed, or modified under this Section, review all associated electrical work, including overload protection devices, and assume complete responsibility for the correctness of the electrical connections and protective devices. Motors and control equipment shall conform to the Standards of the National Electrical Manufacturers' Association. All equipment and connections exposed to the weather shall be NEMA IIIIR with factory-wired strip heaters in each starter enclosure and temperature control panel where required to inhibit condensation.
- C. All line voltage and low voltage wiring and conduit associated with the Temperature Control System are included in this Section. Wiring and conduit shall comply with Division 26.

### 3.5 PIPING SYSTEM REQUIREMENTS

- A. Drawing plans, schematic and diagrams indicate general location and arrangement of piping systems. Indicated locations and arrangements were used to size pipe and calculate friction loss, expansion, pump sizing, and other design considerations. Install piping as indicated unless deviations to layout are approved on coordination drawings.

### 3.6 PRIMING AND PAINTING

- A. Perform all priming and painting on the equipment and materials as specified herein.
- B. Priming:
  - 1. Exposed ferrous metals, including piping, which are not galvanized or factory-finished shall be primed. Black steel pipe exposed to the weather shall be painted one coat of Rust-Oleum #1069 primer for black steel piping or Rust-Oleum #5260, Kelly Moore, or equal, primer for galvanized piping.
  - 2. Metal surfaces of items to be jacketed or insulated except ductwork and piping shall be given two coats of primer unless furnished with equivalent factory finish. Items to be primed shall be properly cleaned by effective means free of rust, dirt, scale, grease and other deleterious matter and then primed with the best available grade of zinc rich primer. After erection or installation, all primed surfaces shall be properly cleaned of any foreign or deleterious matter that might impair proper bonding of subsequent paint coatings. Any abrasion or other damage to the shop or field prime coat shall be properly repaired and touched up with the same material used for the original priming.
  - 3. Where equipment is provided with nameplate data, the nameplate should be masked off prior to painting. When painting is completed, remove masking material.
- C. See Painting Section for detailed requirements.

### 3.7 INSTALLATION OF PIPING AND DUCT SYSTEMS

- A. General:

1. All piping shall be concealed unless shown or otherwise directed. Allow sufficient space for ceiling panel removal.
2. Installation of piping shall be made with appropriate fittings. Bending of piping will not be accepted.
3. Install piping to permit application of insulation and to allow valve servicing.
4. Where piping, conduit, or ductwork is left exposed within a room, the same shall be run true to plumb, horizontal, or intended planes. Where possible, uniform margins are to be maintained between parallel lines and/or adjacent wall, floor, or ceiling surfaces.
5. Horizontal runs of pipes, conduits, or ductwork suspended from ceilings shall provide for a maximum headroom clearance. The clearance shall not be less than 6'-6" without written approval from the Architect.
6. Close ends of pipe immediately after installation. Leave closure in place until removal is necessary for completion of installation.
7. At the time of rough installation, or during storage on the construction site and until final startup of the heating and cooling equipment, all duct and other related air distribution component opening shall be covered with tape, plastic, sheet metal, or other methods acceptable to the enforcing agency.
8. Each piping system shall be thoroughly flushed and proved clean before connection to equipment.
9. Pipe the discharge of each relief valve, air vent, backflow preventer, and similar device to floor sink or drain.
10. Install exposed polished or enameled connections with special care showing no tool marks or threads at fittings.
11. Install horizontal valves with valve stem above horizontal.
12. Use reducing fittings; bushings shall not be allowed. Use eccentric reducing fittings wherever necessary to provide free drainage of lines and passage of air.
13. Verify final equipment locations for roughing-in.
14. Where piping is installed in walls within one inch of the face of stud, provide a 16 gauge sheet metal shield plate on the face of the stud. The shield plate shall extend a minimum of 1-1/2 inches beyond the outside diameter of the pipe.

B. Sleeves:

1. Install Adjus-to-Crete, Pipeline Seal and Insulator, or equal, pipe sleeves of sufficient size to allow for free motion of pipe, 24 gauge galvanized steel. The space between pipe and sleeves through floor slabs on ground, through outside walls above or below grade, through roof, and other locations as directed shall be caulked with oakum and mastic and made watertight. The space between pipe and sleeve and between sleeve and slab or wall shall be sealed watertight.
2. At Contractor's option, Link-Seal, Metraflex Metraseal, or equal, casing seals may be used in lieu of caulking. Wrap pipes through slabs on grade with 1 inch thick fiberglass insulation to completely isolate the pipe from the concrete.

C. Floor, Wall, and Ceiling Plates:

1. Fit all pipes with or without insulation passing through walls, floors, or ceilings, and all hanger rods penetrating finished ceilings with chrome-plated or stainless escutcheon plates.

D. Flashing:

1. Flashing for penetrations of metal or membrane roof for mechanical items such as flues, ducts, and pipes shall be coordinated with the roofing manufacturer and roofing installer for the specific roofing type. The work of this section shall include furnishing, layout, sizing, and coordination of penetrations required for the mechanical work.



- a. Furnish and install flashing and counterflashing in strict conformance with the requirements of the roofing manufacturer. Submit shop drawing details for review prior to installation.
  - b. Furnish and install counterflashing above each flashing required. Provide Stoneman, or equal, vandalproof top and flashing combination. Elmdor/Stoneman Model 1540.
  - c. Flues and ducts shall have 24 gauge galvanized sheet metal storm collar securely clamped to the flue above the flashing.
2. For all other types of roofing system, furnish and install around each pipe, where it passes through roof, a flashing and counterflashing. All flashing shall be made of four pound seamless sheet lead with 6 inch minimum skirt and steel reinforced boot. Counterflashing shall be cast iron. For vents, provide vandalproof top and flashing combination. Elmdor/Stoneman Model 1100-4.

E. Hangers and Supports:

1. General: Support ductwork, equipment and piping so that it is firmly held in place by approved iron hangers and supports, and special hangers. Hanger and support components shall support weight of ductwork, equipment and pipe, fluid, and pipe insulation based on spacing between supports with minimum factor of safety of five based on ultimate strength of material used. Do not exceed manufacturer's load rating. Pipe attachments or hangers, of same size as pipe or tubing on which used, or nearest available. Rigidly fasten hose faucets, fixture stops, compressed air outlets, and similar items to the building construction. The Architect shall approve hanger material before installation. Do not support piping or ductwork with plumbers' tape, wire rope, wood, or other makeshift devices. Where building structural members do not match piping and ductwork support spacing, provide "bridging" support members firmly attached to building structural members in a fashion approved by the structural engineer.
- a. Materials, design, and type numbers for support of piping per Manufacturers' Standardization Society (MSS), Standard Practice (SP)-58.
  - b. Provide copper-plated or felt-lined hangers for use on copper tubing.
  - c. Materials and design for ductwork support shall be per SMACNA "HVAC Duct Construction Standards, Metal and Flexible."
2. Hanger components shall be provided by one manufacturer: B-Line, Grinnell, Unistrut, Badger, or equal.
3. Riser clamps: B-line model B3373, or equal.
4. Pipe Hanger and Support Placement and Spacing:
- a. Vertical piping support spacing: Provide riser clamps for piping, above each floor, in contact with the floor. Provide support at joints, branches, and horizontal offsets. Provide additional support for vertical piping, spaced at or within the following maximum limits:

<u>Pipe Diameter</u>	<u>Steel Threaded or Welded (Note 3)</u>	<u>Copper Brazed or Soldered (Notes 3, 4)</u>	<u>CPVC &amp; PVC (Note 2)</u>
1/2 - 1"	12 ft.	Each Floor, Not to Exceed 10 ft.	Base and Each Floor (Note 1)

1-1/4 - 2"	12 ft.	Each Floor, Not to Exceed 10 ft.	Base and Each Floor (Note 1)
2-1/2 - 3"	12 ft.	Each Floor, Not to Exceed 10 ft.	Base and Each Floor (Note 1)
Over 4"	12 ft.	Each Floor, Not to Exceed 10 ft.	Base and Each Floor (Note 1)

Note 1: Provide mid-story guides.

- 1) Note 2: For PVC piping, provide for expansion every 30 feet per IAPMO installation standard. For CPVC piping, provide for expansion per IAPMO installation standard.
- 2) Note 3: Spacing of hangers and supports for piping assembled with mechanical joints shall be in accordance with standards acceptable to authorities having jurisdiction.
- 3) Note 4: Includes refrigerant piping, including vapor and hot gas pipes.

- b. Horizontal piping, hanger and support spacing: Locate hangers and supports at each change of direction, within one foot of elbow, and spaced at or within following maximum limits:

<u>Pipe Diameter</u>	<u>Steel Threaded or Welded (Note 2)</u>	<u>Copper Brazed or Soldered (Notes 2, 3)</u>	<u>CPVC &amp; PVC (Note 1)</u>
1/2 - 1"	6 ft.	5 ft.	3 ft.
1-1/4 - 2"	7 ft.	6 ft.	4 ft.
2-1/2 - 3"	10 ft.	10 ft.	4 ft.
Over 4"	10 ft.	10 ft.	4 ft.

Note 1: For PVC piping, provide for expansion every 30 feet per IAPMO installation standard. For CPVC piping, provide for expansion per IAPMO installation standard.

- 1) Note 2: Spacing of hangers and supports for piping assembled with mechanical joints shall be in accordance with standards acceptable to authorities having jurisdiction.
- 2) Note 3: Includes all refrigerant piping, including vapor and hot gas pipes.

5. Suspended Piping:

- a. Individually suspended piping: B-Line B3690 J-Hanger or B3100 Clevis, complete with threaded rod, or equal. All hangers on supply and return piping handling heating hot water or steam shall have a swing connector at point of support.

<u>Pipe Size</u>	<u>Rod Size Diameter</u>
2" and Smaller	3/8"
2-1/2" to 3-1/2"	1/2"

4" to 5"	5/8"
6"	3/4"

- b. Trapeze Suspension: B-Line 1-5/8 inch width channel in accordance with manufacturers' published load ratings. No deflection to exceed 1/180 of a span.
  - c. Trapeze Supporting Rods: Shall have a safety factor of five; securely anchor to building structure.
  - d. Pipe Clamps and Straps: B-Line B2000, B2400; isolate copper pipe with two thicknesses of 2 inches wide 10-mil polyvinyl tape. Where used for seismic support systems, provide B-Line B2400 series pipe straps.
  - e. Concrete Inserts: B-line B22-I continuous insert or B2500 spot insert. Do not use actuated fasteners for support of overhead piping unless approved by Architect.
  - f. Above Roof: H frame made from Uni-Strut hot-dipped galvanized 1-5/8 inch single or double channel with P-2072A or P-2073A foot secured to roof and surrounded with waterproof roofed-in sleeper. Secure to sleeper with lag screws, and secure sleeper to blocking under roof.
  - g. Steel Connectors: Beam clamps with retainers.
6. Duct Hanger and Support Spacing: Conform to Requirements of CMC and SMACNA "HVAC Duct Construction Standards, Metal and Flexible."
7. Support to Structure:

- a. Wood Structure: Provide and install wood blocking as required to suit structure. Provide lag screws or through bolts with length to suit requirements, and with size (diameter) to match the size of hanger rods required.
  - 1) Do not install Lag screws in tension without written review and acceptance by Structural Engineer.

Side Beam Angle Clip	B-Line B3062	MSS Type 34
Side Beam Angle Clip	B-Line B3060	
Ceiling Flange	B-Line B3199	

- b. Blocking for support of piping shall be not less than 2 inch thick for piping up to 2 inch size. Provide 3 inch blocking for piping up through 5 inch size, and 4 inch blocking for larger piping. Provide support for blocking in accordance with Structural Engineers requirements.
  - 1) Where lag screws are used, length of screw shall be 1/2 inch less than the wood blocking. Pre-drill starter holes for each lag screw.

8. Rubber Neoprene Pipe Isolators:

- a. Pipe isolators shall comprise an internal rubber or neoprene material that isolates pipe from hanger and structure. Install at all piping located in acoustical walls. Refer to Architectural Drawings for location of acoustical walls.
- b. Isolation material shall be either a rubber or neoprene material that prevents contact between the pipe and the structure. The rubber shall have between a 45 to 55 durometer rating and a minimum thickness of 1/2 inch.
- c. Acceptable Suppliers:

d. Vertical runs: Acousto-Plumb or equal.

1) Horizontal runs: B-Line, Vibraclamp; Acousto-Plumb or equal.

9. Provide support for piping through roof, arranged to anchor piping solidly in place at the roof penetration.
10. Provide rigid insulation and a 12 inch long, 18 gauge galvanized sheet iron shield between the covering and the hanger whenever hangers are installed on the outside of the pipe covering.
11. Insulate copper tubing from ferrous materials and hangers with two thicknesses of 3 inch wide, 10 mil polyvinyl tape wrapped around pipe.
12. Provide a support or hanger close to each change of direction of pipe either horizontal or vertical and as near as possible to concentrated loads.
13. Suspend rods from concrete inserts with removable nuts where suspended from concrete decks. Power actuated inserts will not be allowed.
14. On chilled or combination hot and chilled water or refrigerant pipes, install the hangers on the outside of the pipe covering and not in contact with the pipe. Provide rigid insulation and a 12 inch long, 18 gauge galvanized sheet iron shield between the covering and the hanger whenever hangers are installed on the outside of the pipe covering.

### 3.8 UNIONS AND FLANGES

- A. Install Epco, Nibco, or equal, dielectric unions or flanges at points of connection between copper or brass piping or material and steel or cast iron pipe or material except in drain piping. Bushings or couplings shall not be used.
- B. Install unions in piping NPS 2" and smaller 3 or flanges in piping NPS 2-1/2" and larger whether shown or not at each connection to all equipment and tanks, and at all connections to all automatic valves, such as temperature control valves.
- C. Locate the unions for easy removal of the equipment, tank, or valve.
- D. Do not install unions or flanges in refrigerant piping systems.

### 3.9 ACCESS DOOR

- A. Furnish and install access doors wherever required whether shown or not for easy maintenance of mechanical systems; for example, at concealed valves, strainers, traps, cleanouts, dampers, motors, controls, operating equipment, etc. Access doors shall provide for complete removal and replacement of equipment.

### 3.10 PIPE PROTECTION

- A. Wrap bare galvanized and black steel pipe buried in the ground and to 6" above grade, including piping in conduit, with one of the following, or equal:
  1. Polyethylene Coating: Pressure sensitive polyethylene coating, "X-Tru-Coat" as manufactured by Pipe Line Service Corporation or "Green Line" wrap as manufactured by Royston Products, or equal.
    - a. Field Joints and Fittings: Protecto Wrap #1170 tape as manufactured by Pipe Line Service Corporation, or Primer #200 tape by Royston Products, or equal. Installation shall be as per manufacturer's recommendation and instructions.

2. Tape Wrap: Pressure-sensitive polyvinyl chloride tape, "Transtex #V-10 or V-20", "Scotchwrap 50", Slipknot 100, PASCO Specialty & Mfg., Inc., or equal, with continuous identification. Tape shall be a minimum of 20 mils thick for fittings and irregular surfaces, two wraps, 50 percent overlap, 40 mils total thickness. Tape shall be laminated with a suitable adhesive; widths as recommended by the manufacturer for the pipe size. Wrap straight lengths of piping with an approved wrapping machine.
- B. Field Joints: Valves and Fittings: double wrap polyvinyl chloride tape as above. Provide at least two thicknesses of tape over the joint and extend a minimum of 4 inches over adjacent pipe covering. Build up with primer to match adjacent covering thickness. Width of tape of fittings shall not exceed 3 inches. Tape shall adhere tightly to all surfaces of the fittings without air pockets.
  - C. Testing: Test completed wrap of piping, including all epoxy painted piping with Tinker and Rasor Co. holiday detector, or equal.
  - D. Cleaning: Clean all piping thoroughly before wrapping.
    1. Inspection: Damaged or defective wraps shall be repaired as directed. No wrapped pipe shall be covered until approved by Architect.
  - E. Covering: No rocks or sharp edges shall be backfilled against the wrap. When backfilling with other than sand, protect wrap with an outer wrapping of Kraft paper; leave in place during backfill.

### 3.11 PIPE IDENTIFICATION

- A. Provide temporary identification of each pipe installed, at the time of installation. Temporary identification shall be removed and replaced with permanent identification as part of the work.
- B. Apply the legend and flow arrow at all valve locations; at all points where the piping enters or leaves a wall, partition, cluster of piping or similar obstruction, at each change of direction, and at approximately 20'-0" intervals on pipe runs. Variations or changes in locations and spacing may be made with the approval of the Architect. There shall be at least one marking in each room. Markings shall be located for maximum visibility from expected personnel approach.
- C. Wherever two or more pipes run parallel, the markings shall be supplied in the same relative location on each.
- D. Apply the markings after painting and cleaning of piping and insulation is completed.

### 3.12 PIPING SYSTEM PRESSURE TESTING

- A. General:
  1. Perform operational tests under simulated or actual service conditions.
  2. Repair leaks and defects with new materials, and retest piping or portion thereof until satisfactory results are obtained.
- B. Piping Systems: Test the installations in accordance with the following requirements and applicable codes:
  1. Notify the Architect at least seven days in advance of testing.
  2. Authority having jurisdiction shall witness tests of piping systems.

3. Piping shall be tested at completion of roughing-in, or at other times as directed by the Architect.
4. Furnish necessary materials, test pumps, gases, instruments and labor required for testing.
5. Isolate from system equipment that may be damaged by test pressure.
6. Make connections to existing systems with flanged connection. During testing of new work, provide a slip-in plate to restrict test pressure to new systems. Remove plate and make final connection to existing system at completion of testing.
  - a. Authority having jurisdiction shall witness final connection to system.

C. Test Schedule: No loss in pressure or visible leaks shall show after four hours at the pressures indicated.

<u>System Tested</u>	<u>Test Pressure PSI</u>	<u>Test With</u>
All Hot, Chilled, Combination, Condenser Water Piping	Greater of 1-1/2 x WP or 100 psi	Water

D. Testing, Evacuating, Charging and Lubrication of Refrigeration Systems:

1. Pressurize with dry nitrogen and/or refrigerant to 300 psig and test all joints with an electronic detector or halide torch. Release the pressure and attach a high vacuum pump. Evacuate to 4 mm (4000 microns) and hold for 30 minutes. Break to 5 psig with dry nitrogen and allow to remain in the system for ten minutes. Evacuate to 2 mm (2000 microns) and hold for 30 minutes. Use a mercury manometer or electronic vacuum gauge. Do not start timing until recommended vacuum range is reached.
2. At the end of the evacuation, if the system has been proved leak-free, charge with refrigerant and fill the crankcase to the oil level specified by the manufacturer. All refrigerant oil shall be delivered to the location in sealed containers.
3. Replenish for a period of one year without cost to the Owner all refrigerant and oil required to maintain the proper levels.

### 3.13 OPERATION OF SYSTEMS

- A. Do not operate any mechanical equipment for any purpose, temporary or permanent, until all of the following has been completed:
  1. Complete all requirements listed under "Check, Test and Start Requirements."
  2. Ductwork and piping has been properly cleaned. Piping systems shall be flushed and treated prior to operation.
  3. Filters, strainers etc. are in place.
  4. Bearings have been lubricated, and alignment of rotating equipment has been checked.
  5. Equipment has been run under observation, and is operating in a satisfactory manner.
- B. Provide test and balance agency with one set of Contract Drawings, Specifications, Addenda, Change orders issued, applicable shop drawings and submittals and temperature control drawings.
- C. Operate every fire damper, smoke damper, combination smoke and fire damper under normal operating conditions. Activate smoke detectors as required to operate the damper, stage fan, etc. Provide written confirmation that all systems operate in a satisfactory manner.

### 3.14 TEMPORARY HEAT

- A. The General Contractor will provide for all temporary heat at such times as may be required or directed by the Architect and pay all fuel and energy costs incurred.
- B. Temporary heating facilities proposed for use by the Contractor will be subject to review of the Architect. Prior to use of any equipment for temporary heat, install temporary filters on all return air inlets, to preclude dust and construction debris from entering the duct system. In addition, install filters in air handling units, and replace at the completion of temporary operation.
- C. Filters used for temporary operation of systems shall be as specified for permanent filters specified herein.
- D. Comply with Check, Test and Start Requirements for start-up of equipment prior to operation for temporary heat.

### 3.15 CHECK, TEST AND START REQUIREMENTS

- A. An authorized representative of the equipment manufacturer shall perform check, test and start of each piece of mechanical equipment. The representative may be an employee of the equipment manufacturer, or a manufacturer-certified contractor. Submit written certification from the manufacturer stating that the representative is qualified to perform the check test and start of the equipment.
  - 1. As part of the submittal process, provide a copy of each manufacturer's printed startup form to be used.
  - 2. Some items of specified equipment may require that check, test and start of equipment must be performed by the manufacturer, using manufacturer's employees. See specific equipment Articles in these Specifications for this requirement.
  - 3. Provide all personnel, test instruments, and equipment to properly perform the check, test and start work.
  - 4. When work has been completed, provide copies of reports for review, prior to final observation of work.
- B. Provide copies of the completed check, test and start report of each item of equipment, bound with the Operation and Maintenance Manual.
- C. Upon completion of the work, provide a schedule of planned maintenance for each piece of equipment. Indicate frequency of service, recommended spare parts (including filters and lubricants), and methods for adjustment and alignment of all equipment components. Provide a copy of the schedule with each Operation and Maintenance Manual. Provide a copy of certification from the Owner's representative indicating that they have been properly instructed in maintenance requirements for the equipment installed.

### 3.16 PRELIMINARY OPERATIONAL REQUIREMENTS AND TESTS

- A. Prior to observation to determine final acceptance, put HVAC, plumbing, and fire protection systems into service and check that work required for that purpose has been done, including but not limited to the following condensed check list. Provide indexed report to tabulating the results of all work.
  - 1. All equipment has been started, checked, lubricated and adjusted in accordance with the manufacturer's recommendations, including modulating power exhausts if present.
  - 2. Correct rotation of motors and ratings of overload heaters are verified.

3. Specified filters are installed and spare filters have been turned over to Owner.
  4. All manufacturers' certificates of start-up specified have been delivered to the Owner.
  5. All equipment has been cleaned, and damaged painted finishes touched up.
  6. Damaged fins on heat exchangers have been combed out.
  7. Missing or damaged parts have been replaced.
  8. Flushing and chemical treatment of piping systems has been completed and water treatment equipment, where specified, is in operation.
  9. Equipment labels, pipe marker labels, ceiling markers and valve tags are installed.
  10. Valve tag schedules, corrected control diagrams, sequence of operation lists and start-stop instructions have been posted.
  11. Preliminary test and balance work is complete, and reports have been forwarded for review.
  12. Automatic control set points are as designated and performance of controls checks out to agree with the sequence of operation.
  13. Operation and Maintenance Manuals have been delivered and instructions to the operating personnel have been made.
- B. Prior to the observation to determine final acceptance, operate all mechanical systems as required to demonstrate that the installation and performance of these systems conform to the requirements of these specifications.
1. Operate and test all mechanical equipment and systems for a period of at least five consecutive 8 hour days to demonstrate the satisfactory overall operation of the project as a complete unit.
  2. Include operation of heating and air conditioning equipment and systems for a period of not less than two 8 hour days at not less than 90 percent of full specified heating and cooling capacities in tests.
  3. Commence tests after preliminary balancing and adjustments to equipment have been checked. Immediately before starting tests, install air filters and lubricate all running equipment. Notify the Architect at least seven calendar days in advance of starting the above tests.
  4. During the test period, make final adjustments and balancing of equipment, systems controls, and circuits so that all are placed in first class operating condition.
  5. Where Utility District rebates are applicable, demonstrate that the systems meet the rebate program requirements.
- C. Before handing over the system to Owner replace all filters with complete new set of filters.
- D. Review of Contractor's Tests:
1. All tests made by the Contractor or manufacturers' representatives are subject to observation and review by the Owner. Provide timely notice prior to start of each test, in order to allow for observation of testing. Upon the completion of all tests, provide a letter to confirm that all testing has been successful.
- E. Test Logs:
1. Maintain test logs listing the tests on all mechanical systems showing dates, items tested, inspectors' names, remarks on success or failure of the tests.
- F. Preliminary Operation:
1. The Owner reserves the right to operate portions of the mechanical system on a preliminary basis without voiding the guarantee.



G. Operational Tests:

1. Before operational tests are performed, demonstrate that all systems and components are complete and fully charged with operating fluid and lubricants.
2. Systems shall be operable and capable of maintaining continuous uninterrupted operation during the operating and demonstration period. After all systems have been completely installed, connections made, and tests completed, operate the systems continuously for a period of five working days during the hours of a normal working day.
3. This period of continuous systems operation may be coordinated with the removal of Volatile Organic Compounds (VOCs) from the building prior to occupancy should the Owner decide to implement such a program.
4. Control systems shall be completely operable with settings properly calibrated and adjusted.
5. Rotating equipment shall be in dynamic balance and alignment.
6. If the system fails to operate continuously during the test period, the deficiencies shall be corrected and the entire test repeated.

H. Pre-Occupancy Building Purge:

1. Prior to occupancy, ventilate the building on 100 percent outside air, 100 percent exhaust for a continuous period determined by a qualified industrial hygienist (engaged by the Contractor) to reduce V.O.C's prior to occupancy.
2. Submit report by the industrial hygienist verifying satisfactory completion of the pre-occupancy purge.

3.17 CERTIFICATES OF INSTALLATION

- A. Contractor shall complete applicable "Certificates of Installation" forms contained in the California Building Energy Efficiency Standards and submit to the authorities having jurisdiction for approval and issuance of final occupancy permit, as described in the California Energy Code.

3.18 ACCEPTANCE REQUIREMENTS

- A. Contractor shall complete the applicable Acceptance Requirements for Code Compliance contained in the California Building Energy Efficiency Standards. Refer to T-24 compliance forms on Drawings for systems having Acceptance testing requirements. Contractor shall perform Acceptance tests and complete the appropriate "Certificates of Acceptance." Submit certificates to the authorities having jurisdiction for approval and issuance of final occupancy permit. Contractor shall engage certified HERS Rater to verify duct leakage rate for duct systems indicated on T-24 compliance forms on Drawings as requiring duct leakage rate testing. For additional duct leak testing requirements, refer to Section 23 80 00, "Heating, Ventilating, and Air Conditioning," Article, "Ductwork Sealing and Leak Testing."

3.19 DEMONSTRATION AND TRAINING

- A. An authorized representative of the equipment manufacturer shall train Owner-designated personnel in maintenance and adjustment of equipment. The representative may be an employee of the equipment manufacturer, or a manufacturer-certified contractor. Submit written certification from the manufacturer stating that the representative is qualified to perform the Owner training for the equipment installed.

1. As part of the submittal process, provide a training agenda outlining major topics and time allowed for each topic.

2. Some items of specified equipment require that training must be performed by the manufacturer, using manufacturer's employees. See specific equipment Articles in these Specifications for this requirement.
3. Contractor shall provide three copies of certification by Contractor that training has been completed, signed by Owner's representative, for inclusion in Operation and Maintenance Manual. Certificates shall include:
  - a. Listing of Owner-designated personnel completing training, by name and title.
  - b. Name and title of training instructor.
  - c. Date(s) of training.
  - d. List of topics covered in training sessions.
4. Refer to specific equipment Articles for minimum training period duration for each piece of equipment.

**END OF SECTION 23 00 50**

**SECTION 23 05 93 - TESTING, ADJUSTING, AND BALANCING FOR HVAC**

**PART 1 - GENERAL**

**1.1 SUMMARY**

- A. Section Includes:
  - 1. Balancing Air Systems:
  - 2. Constant-volume air systems.
  - 3. Balancing Domestic Water Piping Systems.

**1.2 RELATED REQUIREMENTS**

- A. Drawings and general provisions of the Contract, including General and Supplementary Conditions and Division 01 Specification Sections, apply to this Section.

**1.3 REFERENCES AND STANDARDS**

- A. Associated Air Balance Council (AABC)
- B. National Standards for Total System Balance, latest edition.
- C. National Environmental Balancing Bureau (NEBB)
- D. Procedural Standards for Testing and Balancing of Environmental Systems, latest edition.

**1.4 DEFINITIONS**

- A. The intent of this Section is to use the standards pertaining to the TAB specialist engaged to perform the Work of this Contract, with additional requirements specified in this Section. Contract requirements take precedence over corresponding AABC or NEBB standards requirements. Differences in terminology between the Specifications and the specified TAB organization standards do not relieve the TAB entity engaged to perform the Work of this Contract of responsibility from completing the Work as described in the Specifications.
- B. Similar Terms: The following table is provided for clarification only:

<u>Similar Terms</u>		
Contract Term	AABC Term	NEBB Term
TAB Specialist	TAB Agency	NEBB Certified Firm
TAB Standard	National Standards for Testing and Balancing Heating, Ventilating, and Air Conditioning Systems	Procedural Standards for Testing, Adjusting, and Balancing of Environmental Systems
TAB Field Supervisor	Test and Balance Engineer	Test and Balance Supervisor

1. AABC: Associated Air Balance Council.
2. NEBB: National Environmental Balancing Bureau.
3. TAB: Testing, adjusting, and balancing.
4. TAB Organization: Body governing practices of TAB Specialists.
5. TAB Specialist: An entity engaged to perform TAB Work.

#### 1.5 INFORMATIONAL SUBMITTALS

- A. Qualification Data: Within 30 days of Contractor's Notice to Proceed, submit documentation that the TAB specialist and this Project's TAB team members meet the qualifications specified in "Quality Assurance" Article.
  1. Provide list of similar projects completed by proposed TAB field supervisor.
  2. Provide copy of completed TAB report, approved by mechanical engineer of record for a completed project with similar system types and of similar complexity.
- B. Contract Documents Examination Report: Within 30 days of Contractor's Notice to Proceed, submit the Contract Documents review report as specified in Part 3.
  1. Submit examinations report with qualifications data.
- C. Strategies and Procedures Plan: Within 60 days of Contractor's Notice to Proceed, submit TAB strategies and step-by-step procedures as specified in "Preparation" Article.
- D. Interim Reports. Submit interim reports as specified in Part 3. Include list of system conditions requiring correction and problems not identified in Contract Documents examination report.
- E. Certified TAB reports.
  1. Provide three printed copies of final TAB report. Provide one electronic file copy in PDF format.
- F. Sample report forms.
- G. Instrument calibration reports, to include the following:
  1. Instrument type and make.
  2. Serial number.
  3. Application.
  4. Dates of use.
  5. Dates of calibration.
    - a. Instruments to be used for testing and balancing shall have been calibrated within a period of one year, or less if so recommended by instrument manufacturer and be checked for accuracy prior to start of work.

#### 1.6 CLOSEOUT SUBMITTALS

- A. For additional requirements, refer to Section 22 00 50, Basic HVAC Materials and Methods.
- B. Certified TAB reports, for inclusion in Operation and Maintenance Manual.

#### 1.7 QUALITY ASSURANCE

- A. Independent TAB Specialist Qualifications: Engage a TAB entity certified by AABC or NEBB.

1. The certification shall be maintained for the entire duration of TAB work for this Project. If TAB specialist loses certification during this period, the Contractor shall immediately notify the Architect and submit another TAB specialist for approval. All work specified in this Section and in other related Sections performed by the TAB specialist shall be invalidated if the TAB specialist loses certification, and shall be performed by an approved successor.
- B. To secure approval for the proposed TAB specialist, submit information certifying that the TAB specialist is either a first tier subcontractor engaged and paid by the Contractor, or is engaged and paid directly by the Owner. TAB specialist shall not be affiliated with any other entity participating in Work of this Contract, including design, furnishing equipment, or construction. In addition, submit evidence of the following:
  1. TAB Field Supervisor: Full-time employee of the TAB specialist and certified by AABC or NEBB.
    - a. TAB field supervisor shall have minimum 10 years supervisory experience in TAB work.
  2. TAB Technician: Full-time employee of the TAB specialist and who is certified by AABC or NEBB as a TAB technician.
    - a. TAB technician shall have minimum 4 years TAB field experience.
- C. TAB Specialist engaged to perform TAB work in this Project shall be a business limited to and specializing in TAB work.
- D. Certified TAB field supervisor or certified TAB technician shall be present at the Project site at all times when TAB work is performed.
  1. TAB specialist shall maintain at the Project site a minimum ratio of one certified field supervisor or technician for each non-certified employee at times when TAB work is being performed.
- E. Contractor shall notify Architect in writing within three days of receiving direction resulting in reduction of test and balance scope or other deviations from Contract Documents. Deviations from the TAB plan shall be approved in writing by the mechanical engineer of record for the Project.
- F. TAB Standard:
  1. Perform TAB work in accordance with the requirements of the standard under which the TAB agencies' qualifications are approved unless Specifications contain different or more stringent requirements:
    - a. AABC National Standards for Total System Balance, or
    - b. NEBB Procedural Standards for Testing, Adjusting, Balancing of Environmental Systems.
  2. All recommendations and suggested practices contained in the TAB standard are mandatory. Use provisions of the TAB standard, including checklists and report forms, to the extent to which they are applicable to this Project.
  3. Testing, adjusting, balancing procedures, and reporting required for this Project, and not covered by the TAB standard applicable to the TAB specialist engaged to perform the Work of this Contract, shall be submitted for approval by the design engineer.

- G. TAB Conference: Meet with Architect and mechanical engineer on approval of the TAB strategies and procedures plan to develop a mutual understanding of the project requirements. Require the participation of the TAB field supervisor. Provide seven days' advance notice of scheduled meeting time and location. TAB conference shall take place at location selected by Architect .

1. Agenda Items:

- a. The Contract Documents examination report.
- b. The TAB plan.
- c. Coordination and cooperation of trades and subcontractors.
- d. Coordination of documentation and communication flow, including protocol for resolution tracking and documentation.

2. The requirement for TAB conference may be waived at the discretion of the mechanical engineer of record for the Project.

- H. Certify TAB field data reports and perform the following:

1. Review field data reports to validate accuracy of data and to prepare certified TAB reports.
2. Certify that the TAB team complied with the approved TAB plan and the procedures specified and referenced in this Specification.

- I. TAB Report Forms: Use standard TAB specialist's forms approved by Architect .

- J. Instrumentation Type, Quantity, Accuracy, and Calibration: As described in ASHRAE 111, Section 5, "Instrumentation."

## 1.8 WARRANTY

- A. Provide workmanship and performance warranty applicable to TAB specialist engaged to perform Work of this Contract:

1. AABC Performance Guarantee.
2. NEBB Quality Assurance Program.

- B. Refer to Division 01 Specifications for additional requirements.

## 1.9 COORDINATION

- A. Notice: Provide seven days' advance notice for each test. Include scheduled test dates and times.
- B. Perform TAB after leakage and pressure tests on air and water distribution systems have been satisfactorily completed.
- C. Coordinate TAB work with work of other trades.

PART 2 - PRODUCTS (Not Applicable)

PART 3 - EXECUTION

3.1 EXAMINATION

A. Contract Documents Examination Report:

1. TAB specialist shall review Contract Documents, including plans and specifications. Provide report listing conditions that would prevent the system(s) from operating in accordance with the sequence of operations specified, or would prevent accurate testing and balancing:
  - a. Identify each condition requiring correction using equipment designation shown on Drawings. Provide room number, nearest building grid line intersection, or other information necessary to identify location of condition requiring correction.
  - b. Proposed corrective action necessary for proper system operation.

B. Examine systems for installed balancing devices, such as test ports, gage cocks, thermometer wells, flow-control devices, balancing valves and fittings, and manual volume dampers. Verify that locations of these balancing devices are accessible.

C. Examine the approved submittals for HVAC systems and equipment.

D. Examine design data including HVAC system descriptions, statements of design assumptions for environmental conditions and systems' output, and statements of philosophies and assumptions about HVAC system and equipment controls.

E. Examine equipment performance data including fan and pump curves.

1. Relate performance data to Project conditions and requirements, including system effects that can create undesired or unpredicted conditions that cause reduced capacities in all or part of a system.

F. Examine system and equipment installations and verify that field quality-control testing, cleaning, and adjusting specified in individual Sections have been performed.

G. Examine test reports specified in individual system and equipment Sections.

H. Examine HVAC equipment and filters and verify that bearings are greased, belts are aligned and tight, and equipment with functioning controls is ready for operation.

I. Examine heat-transfer coils for correct piping connections and for clean and straight fins.

J. Examine system pumps to ensure absence of entrained air in the suction piping.

K. Examine operating safety interlocks and controls on HVAC equipment.

L. Report conditions requiring correction discovered before and during performance of TAB procedures.

M. Observe and record system reactions to changes in conditions. Record default set points if different from indicated values.

### 3.2 PREPARATION

- A. Prepare a TAB plan that includes strategies and step-by-step procedures. TAB plan shall be specific to Project and include the following:
  - 1. General description of each air system and sequence(s) of operation.
  - 2. Complete list of measurements to be performed.
  - 3. Complete list of measurement procedures. Specify types of instruments to be utilized and method of instrument application.
  - 4. Qualifications of personnel assigned to Project.
  - 5. Single-line CAD drawings reflecting all test locations (terminal units, grilles, diffusers, traverse locations, etc).
  - 6. Air terminal correction factors for the following:
    - a. Air terminal configuration.
    - b. Flow direction (supply or return/exhaust).
    - c. Effective area of each size and type of air terminal.
    - d. Air density.
- B. Complete system-readiness checks and prepare reports. Verify the following:
  - 1. Permanent electrical-power wiring is complete.
  - 2. Automatic temperature-control systems are operational.
  - 3. Equipment and duct access doors are securely closed.
  - 4. Balance, smoke, and fire dampers are open.
  - 5. Isolating and balancing valves are open and control valves are operational.
  - 6. Ceilings are installed in critical areas where air-pattern adjustments are required and access to balancing devices is provided.
  - 7. Windows and doors can be closed so indicated conditions for system operations can be met.

### 3.3 GENERAL PROCEDURES FOR TESTING AND BALANCING

- A. Perform testing and balancing procedures on each system according to the procedures contained in AABC's "National Standards for Total System Balance" or NEBB's "Procedural Standards for Testing, Adjusting, and Balancing of Environmental Systems" and in this Section.
- B. Cut insulation, ducts, pipes, and equipment cabinets for installation of test probes to the minimum extent necessary for TAB procedures.
  - 1. After testing and balancing, patch probe holes in ducts with same material and thickness as used to construct ducts.
  - 2. Install and join new insulation that matches removed materials. Restore insulation, coverings, vapor barrier, and finish according to Section 23 80 00 Heating, Ventilating, and Air Conditioning."
- C. Mark equipment and balancing devices, including damper-control positions, valve position indicators, fan-speed-control levers, and similar controls and devices, with paint or other suitable, permanent identification material to show final settings.
- D. Take and report testing and balancing measurements in inch-pound (IP) units.



### 3.4 GENERAL PROCEDURES FOR BALANCING AIR SYSTEMS

- A. Prepare test reports for both fans and outlets. Obtain manufacturer's outlet factors and recommended testing procedures. Crosscheck the summation of required outlet volumes with required fan volumes.
- B. Test each system to verify building or space operating pressure, including all stages of economizer cycle. Maximum building pressure shall not exceed 0.03 inches of pressure.
- C. Except as specifically indicated in this Specification, Pitot tube traverses shall be made of each duct to measure airflow. Pitot tubes, associated instruments, traverses, and techniques shall conform to ASHRAE Handbook, HVAC Applications, and ASHRAE Handbook, HVAC Systems and Equipment.
  - 1. Use state-of-the-art instrumentation approved by TAB specialists governing agency..
  - 2. Where ducts' design velocity and air quantity are both less than 1000 fpm/CFM, air quantity may be determined by measurements at terminals served.
- D. Test holes shall be placed in straight duct, as far as possible downstream from elbow, bends, take-offs, and other turbulence-generating devices.
- E. Determine the best locations in main and branch ducts for accurate duct-airflow measurements.
- F. Check airflow patterns from the outdoor-air louvers and dampers and the return- and exhaust-air dampers through the supply-fan discharge and mixing dampers.
- G. Locate start-stop and disconnect switches, electrical interlocks, and motor starters.
- H. Verify that motor starters are equipped with properly sized thermal protection.
- I. Check dampers for proper position to achieve desired airflow path.
- J. Check for airflow blockages.
- K. Check condensate drains for proper connections and functioning.
- L. Check for proper sealing of air-handling-unit components.
- M. Verify that air duct system is sealed as specified in Section 23 80 00 "Heating, Ventilating, and Air Conditioning."
- N. Provide for adjustments or modifications to fan and motor sheaves, belts, damper linkages, and other components as required to achieve specified air balance at no additional cost to Owner.
- O. Automatically operated dampers shall be adjusted to operate as indicated in Contract Documents. Controls shall be checked for proper calibration.

### 3.5 PROCEDURES FOR CONSTANT-VOLUME AIR SYSTEMS

- A. Adjust fans to deliver total indicated airflows within the maximum allowable fan speed listed by fan manufacturer.
  - 1. Measure total airflow.

- a. Where sufficient space in ducts is unavailable for Pitot-tube traverse measurements, measure airflow at terminal outlets and inlets and calculate the total airflow. Alternative methods shall be examined for determining total CFM, i.e., Pitot-tube traversing of branch ducts, coil or filter velocity profiles, prior to utilizing airflow values at terminal outlets and inlets.
2. Measure fan static pressures as follows to determine actual static pressure:
  - a. Measure outlet static pressure as far downstream from the fan as practical and upstream from restrictions in ducts such as elbows and transitions.
  - b. Measure static pressure directly at the fan outlet.
  - c. Measure inlet static pressure of single-inlet fans in the inlet duct as near the fan as possible, upstream from the flexible connection, and downstream from duct restrictions.
  - d. Measure inlet static pressure of double-inlet fans through the wall of the plenum that houses the fan.
3. Measure static pressure across each component that makes up an air-handling unit, rooftop unit, and other air-handling and -treating equipment.
  - a. Report the cleanliness status of filters and the time static pressures are measured.
4. Measure static pressures entering and leaving other devices, such as sound traps, heat-recovery equipment, and air washers, under final balanced conditions.
5. Review Record Documents to determine variations in design static pressures versus actual static pressures. Calculate actual system-effect factors. Recommend adjustments to accommodate actual conditions.
6. Obtain approval from Architect for adjustment of fan speed higher or lower than indicated speed. Comply with requirements in HVAC Sections for air-handling units for adjustment of fans, belts, and pulley sizes to achieve indicated air-handling-unit performance.
7. Do not make fan-speed adjustments that result in motor overload. Consult equipment manufacturers about fan-speed safety factors. Modulate dampers and measure fan-motor amperage to ensure that no overload will occur. Measure amperage in full-cooling, full-heating, economizer, and any other operating mode to determine the maximum required brake horsepower.
- B. Check operation of relief air dampers. Measure total relief air quantity at each stage of normal, economizer, power exhaust, or power exhaust economizer operation, as applicable to installed equipment. Adjust relief air dampers to provide 100 percent relief in economizer mode. Ensure that relief dampers close completely upon unit shutdown.
- C. Check operation of outside air dampers. Measure total outside air quantity at each stage of normal, economizer, power exhaust, or power exhaust economizer operation, as applicable to installed equipment. Adjust outside air dampers to provide 100 percent outside air in economizer mode. Ensure that outside air dampers close completely upon unit shutdown.
- D. Adjust volume dampers for main duct, submain ducts, and major branch ducts to indicated airflows within specified tolerances.
  1. Measure airflow of submain and branch ducts.
    - a. Where sufficient space in submain and branch ducts is unavailable for Pitot-tube traverse measurements, measure airflow at terminal outlets and inlets and calculate the total airflow for that zone.

2. Measure static pressure at a point downstream from the balancing damper, and adjust volume dampers until the proper static pressure is achieved.
  3. Remeasure each submain and branch duct after all have been adjusted. Continue to adjust submain and branch ducts to indicated airflows within specified tolerances.
- E. Measure air outlets and inlets without making adjustments.
1. Measure terminal outlets using a direct-reading digital backflow compensating hood. Use outlet manufacturer's written instructions and calculating factors only when direct-reading hood cannot be used due to physical obstruction or other limiting factors. Final report shall indicate where values listed have not been obtained by direct measurement.
- F. Adjust air outlets and inlets for each space to indicated airflows within specified tolerances of indicated values. Make adjustments using branch volume dampers rather than extractors and the dampers at air terminals.
1. Adjust each outlet in same room or space to within specified tolerances of indicated quantities without generating noise levels above the limitations prescribed by the Contract Documents, if included.
  2. Adjust patterns of adjustable outlets for proper distribution without drafts. Terminal air velocity at five feet above finished floor shall not exceed 50 feet per minute in occupied air conditioned spaces.
- G. Do not overpressurize ducts.

### 3.6 PROCEDURES FOR MOTORS

- A. Motors, 1/2 HP and Larger: Test at final balanced conditions and record the following data:
1. Manufacturer's name, model number, and serial number.
  2. Motor horsepower rating.
  3. Motor rpm.
  4. Efficiency rating.
  5. Nameplate and measured voltage, each phase.
  6. Nameplate and measured amperage, each phase.
  7. Starter manufacturer's name, model number, size, type, and thermal-protection-element rating.
    - a. Starter strip heater size, type, and rating.
- B. Motors Driven by Variable-Frequency Controllers: Test for proper operation at speeds varying from minimum to maximum. Test the manual bypass of the controller to prove proper operation. Record observations including name of controller manufacturer, model number, serial number, and nameplate data.

### 3.7 PROCEDURES FOR HEAT-TRANSFER COILS

- A. Measure, adjust, and record the following data for each refrigerant coil:
1. Dry-bulb temperature of entering and leaving air.
  2. Wet-bulb temperature of entering and leaving air.
  3. Airflow.
  4. Air pressure drop.

### 3.8 GENERAL PROCEDURES FOR PLUMBING SYSTEMS

- A. Measure pressure drop across each backflow preventer assembly at design flows.
- B. Measure water flow at pumps. Use the following procedures except for positive-displacement pumps:
  - 1. Verify impeller size by operating the pump with the discharge valve closed. Read pressure differential across the pump. Convert pressure to head and correct for differences in gage heights. Note the point on manufacturer's pump curve at zero flow and verify that the pump has the intended impeller size.
    - a. If impeller sizes must be adjusted to achieve pump performance, obtain approval from Architect Owner and comply with requirements in Section 22 50 00 "Plumbing Equipment"
  - 2. Check system resistance. With all valves open, read pressure differential across the pump and mark pump manufacturer's head-capacity curve. Adjust pump discharge valve until indicated water flow is achieved.
    - a. Monitor motor performance during procedures and do not operate motors in overload conditions.
  - 3. Verify pump-motor brake horsepower. Calculate the intended brake horsepower for the system based on pump manufacturer's performance data. Compare calculated brake horsepower with nameplate data on the pump motor. Report conditions where actual amperage exceeds motor nameplate amperage.
  - 4. Report flow rates that are not within range given in article, Tolerances.
- C. Set calibrated balancing valves, if installed, at calculated presettings.
- D. Measure flow at all stations and adjust, where necessary, to obtain first balance.
  - 1. System components that have Cv rating or an accurately cataloged flow-pressure-drop relationship may be used as a flow-indicating device.
- E. Measure flow at main balancing station and set main balancing device to achieve flow that is 5 percent greater than indicated flow.
- F. Adjust balancing stations to within specified tolerances of indicated flow rate as follows:
  - 1. Determine the balancing station with the highest percentage over indicated flow.
  - 2. Adjust each station in turn, beginning with the station with the highest percentage over indicated flow and proceeding to the station with the lowest percentage over indicated flow.
  - 3. Record settings and mark balancing devices.
- G. Measure pump flow rate and make final measurements of pump amperage, voltage, rpm, pump heads, and systems' pressures and temperatures including outdoor-air temperature.
- H. Measure the differential-pressure-control-valve settings existing at the conclusion of balancing.
- I. Check settings and operation of each safety valve. Record settings.

### 3.9 TOLERANCES

- A. Set HVAC system's air flow rates and water flow rates within the following tolerances:
  - 1. Supply, Return, and Exhaust Fans and Equipment with Fans: Plus 10 percent and minus 0 percent .
  - 2. Air Outlets and Inlets: Plus 5 percent and minus 5 percent .
  - 3. Multiple outlets within single room: Plus 5 percent and minus 0 percent for total airflow within room. Tolerance for individual outlets within a single room having multiple outlets shall be as for "Air Outlets and Inlets".
    - a. Room shall be balanced to create pressure relationship (positive, negative, or neutral) with adjacent spaces as indicated on Drawings. Maintain airflow differentials between supply, return, and exhaust indicated on Drawings.
- B. Set plumbing systems water flow rates within plus or minus 10 percent.

### 3.10 REPORTING

- A. Initial Construction-Phase Report: Based on examination of the Contract Documents as specified in "Examination" Article, prepare a report on the adequacy of design for systems' balancing devices. Recommend changes and additions to systems' balancing devices to facilitate proper performance measuring and balancing. Recommend changes and additions to HVAC systems and general construction to allow access for performance measuring and balancing devices.
- B. Interim Reports: Prepare periodic lists of conditions requiring correction and problems found in systems being tested and balanced. Prepare a separate report for each system and each building floor for systems serving multiple floors.

### 3.11 FINAL REPORT

- A. General: Prepare a certified written report; tabulate and divide the report into separate sections for tested systems and balanced systems.
  - 1. Include a certification sheet at the front of the report's binder, signed and sealed by the certified testing and balancing field supervisor. Report shall be co-signed by the Contractor, attesting that he has reviewed the report, and the report has been found to be complete and accurate.
  - 2. The certification sheet shall be followed by sheet(s) listing items for which balancing objectives could not be achieved. Provide explanation for failure to achieve balancing objectives for each item listed.
  - 3. Include a list of instruments used for procedures, along with proof of calibration.
- B. Final Report Contents: In addition to certified field-report data, include the following:
  - 1. Pump curves.
  - 2. Fan curves.
  - 3. Manufacturers' test data.
  - 4. Field test reports prepared by system and equipment installers.
  - 5. Other information relative to equipment performance; do not include Shop Drawings and product data.
- C. General Report Data: In addition to form titles and entries, include the following data:

1. Title page.
  2. Name and address of the TAB specialist.
  3. Project name.
  4. Project location.
  5. Project Performance Guaranty
  6. Architect's name and address.
  7. Engineer's name and address.
  8. Contractor's name and address.
  9. Report date.
  10. Signature of TAB supervisor who certifies the report.
  11. Table of Contents with the total number of pages defined for each section of the report. Number each page in the report.
  12. Summary of contents including the following:
    - a. Indicated versus final performance.
    - b. Notable characteristics of systems.
    - c. Description of system operation sequence if it varies from the Contract Documents.
  13. Nomenclature sheets for each item of equipment.
  14. Test conditions for fans and pump performance forms including the following:
    - a. Settings for outdoor-, return-, and exhaust-air dampers.
    - b. Conditions of filters.
    - c. Cooling coil, wet- and dry-bulb conditions.
    - d. Fan drive settings including settings and percentage of maximum pitch diameter.
    - e. Settings for supply-air, static-pressure controller.
    - f. Other system operating conditions that affect performance.
- D. System Diagrams: Include schematic layouts of air and hydronic distribution systems. Present each system with single-line diagram and include the following:
1. Quantities of outdoor, supply, return, and exhaust airflows.
  2. Duct, outlet, and inlet sizes.
  3. Pipe and valve sizes and locations.
  4. Balancing stations.
  5. Position of balancing devices.
- E. Air distribution outlets and inlets shall be shown on keyed plans with designation for each outlet and inlet matching designation used in Contract Documents and TAB test reports. Room numbers shall be included in keyed plans and test reports. Where multiple outlets and inlets are installed within a single room, a designation shall be assigned and listed for each outlet and inlet in addition to room number.
- F. Test Reports – General:
1. All test reports containing air or liquid flow data shall record flow values prior to system adjustment in addition to required data listed for each test report.
- G. Air-Handling-Unit Test Reports: For air-handling units with coils, include the following:
1. Unit Data:
    - a. Unit identification.
    - b. Location.
    - c. Make and type.

- d. Model number and unit size.
- e. Manufacturer's serial number.
- f. Unit arrangement and class.
- g. Discharge arrangement.
- h. Sheave make, size in inches, and bore.
- i. Center-to-center dimensions of sheave, and amount of adjustments in inches.
- j. Number, make, and size of belts.
- k. Number, type, and size of filters.

2. Motor Data:

- a. Motor make, and frame type and size.
- b. Horsepower and rpm.
- c. Volts, phase, and hertz.
- d. Full-load amperage and service factor.
- e. Sheave make, size in inches, and bore.
- f. Center-to-center dimensions of sheave, and amount of adjustments in inches.

3. Test Data (Indicated and Actual Values):

- a. Total air flow rate in cfm.
- b. Total system static pressure in inches wg.
- c. Fan rpm.
- d. Discharge static pressure in inches wg.
- e. Filter static-pressure differential in inches wg.
- f. Cooling-coil static-pressure differential in inches wg.
- g. Heating-coil static-pressure differential in inches wg.
- h. Outdoor airflow in cfm.
- i. Return airflow in cfm.
- j. Relief airflow in cfm.
- k. Outdoor-air damper position, normal and economizer, power exhaust, or power exhaust economizer modes, as applicable to installed equipment.
- l. Return-air damper position.
- m. Relief-air damper position, normal and economizer, power exhaust, or power exhaust economizer modes, as applicable to installed equipment.

H. Apparatus-Coil Test Reports:

1. Coil Data:

- a. System identification.
- b. Location.
- c. Coil type.
- d. Number of rows.
- e. Fin spacing in fins per inch o.c.
- f. Make and model number.
- g. Face area in sq. ft.
- h. Tube size in NPS.
- i. Tube and fin materials.
- j. Circuiting arrangement.

2. Test Data (Indicated and Actual Values):

- a. Air flow rate in cfm.
- b. Average face velocity in fpm.

- c. Air pressure drop in inches wg.
    - d. Outdoor-air, wet- and dry-bulb temperatures in deg F.
    - e. Return-air, wet- and dry-bulb temperatures in deg F.
    - f. Entering-air, wet- and dry-bulb temperatures in deg F.
    - g. Leaving-air, wet- and dry-bulb temperatures in deg F.
    - h. Refrigerant expansion valve and refrigerant types.
  - I. Fan Test Reports: For supply, return, and exhaust fans, include the following:
    1. Fan Data:
      - a. System identification.
      - b. Location.
      - c. Make and type.
      - d. Model number and size.
      - e. Manufacturer's serial number.
      - f. Arrangement and class.
      - g. Sheave make, size in inches, and bore.
      - h. Center-to-center dimensions of sheave, and amount of adjustments in inches.
    2. Motor Data:
      - a. Motor make, and frame type and size.
      - b. Horsepower and rpm.
      - c. Volts, phase, and hertz.
      - d. Full-load amperage and service factor.
      - e. Sheave make, size in inches, and bore.
      - f. Center-to-center dimensions of sheave, and amount of adjustments in inches.
      - g. Number, make, and size of belts.
    3. Test Data (Indicated and Actual Values):
      - a. Total airflow rate in cfm.
      - b. Total system static pressure in inches wg.
      - c. Fan rpm.
      - d. Discharge static pressure in inches wg.
      - e. Suction static pressure in inches wg.
  - J. Round, Flat-Oval, and Rectangular Duct Traverse Reports: Include a diagram with a grid representing the duct cross-section and record the following:
    1. Report Data:
      - a. System and air-handling-unit number.
      - b. Location and zone.
      - c. Traverse air temperature in deg F.
      - d. Duct static pressure in inches wg.
      - e. Duct size in inches.
      - f. Duct area in sq. ft..
      - g. Indicated air flow rate in cfm.
      - h. Indicated velocity in fpm.
      - i. Actual air flow rate in cfm.
      - j. Actual average velocity in fpm.
      - k. Barometric pressure in psig.



K. Air-Terminal-Device Reports:

1. Unit Data:
  - a. System and air-handling unit identification.
  - b. Location and zone.
  - c. Apparatus used for test.
  - d. Area served.
  - e. Make.
  - f. Number from system diagram.
  - g. Type and model number.
  - h. Size.
  - i. Effective area in sq. ft.
2. Test Data (Indicated and Actual Values):
  - a. Air flow rate in cfm.
  - b. Air velocity in fpm.
  - c. Preliminary air flow rate as needed in cfm.
  - d. Preliminary velocity as needed in fpm.
  - e. Final air flow rate in cfm.
  - f. Final velocity in fpm.
  - g. Space temperature in deg F.

L. Pump Test Reports: Calculate impeller size by plotting the shutoff head on pump curves and include the following:

1. Unit Data:
  - a. Unit identification.
  - b. Location.
  - c. Service.
  - d. Make and size.
  - e. Model number and serial number.
  - f. Water flow rate in gpm.
  - g. Water pressure differential in feet of head or psig.
  - h. Required net positive suction head in feet of head or psig.
  - i. Pump rpm.
  - j. Impeller diameter in inches.
  - k. Motor make and frame size.
  - l. Motor horsepower and rpm.
  - m. Voltage at each connection.
  - n. Amperage for each phase.
  - o. Full-load amperage and service factor.
  - p. Seal type.
2. Test Data (Indicated and Actual Values):
  - a. Static head in feet of head or psig.
  - b. Pump shutoff pressure in feet of head or psig.
  - c. Actual impeller size in inches.
  - d. Full-open flow rate in gpm.
  - e. Full-open pressure in feet of head or psig.
  - f. Final discharge pressure in feet of head or psig.
  - g. Final suction pressure in feet of head or psig.

- h. Final total pressure in feet of head or psig.
- i. Final water flow rate in gpm.
- j. Voltage at each connection.
- k. Amperage for each phase.

M. Instrument Calibration Reports:

1. Report Data:

- a. Instrument type and make.
- b. Serial number.
- c. Application.
- d. Dates of use.
- e. Dates of calibration.

3.12 INSPECTIONS

A. Initial Inspection:

- 1. After testing and balancing are complete, operate each system and randomly check measurements to verify that the system is operating according to the final test and balance readings documented in the final report.
- 2. Check the following for each system:
  - a. Measure airflow of at least 10 percent of air outlets.
  - b. Measure water flow of at least 5 percent of terminals.
  - c. Measure room temperature at each thermostat/temperature sensor. Compare the reading to the set point.
  - d. Verify that balancing devices are marked with final balance position.
  - e. Note deviations from the Contract Documents in the final report.

B. Final Inspection:

- 1. After initial inspection is complete and documentation by random checks verifies that testing and balancing are complete and accurately documented in the final report, request that a final inspection be made by Architect .
- 2. The TAB specialist's test and balance engineer shall conduct the inspection in the presence of Architect .
- 3. Architect shall randomly select measurements, documented in the final report, to be rechecked. Rechecking shall be limited to either 10 percent of the total measurements recorded or the extent of measurements that can be accomplished in a normal 8-hour business day.
- 4. If rechecks yield measurements that differ from the measurements documented in the final report by more than 10 percent, the measurements shall be noted as "FAILED."
- 5. If the number of "FAILED" measurements is greater than 10 percent of the total measurements checked during the final inspection, the testing and balancing shall be considered incomplete and shall be rejected.

C. TAB Work will be considered defective if it does not pass final inspections. If TAB Work fails, proceed as follows:

- 1. Recheck all measurements and make adjustments. Revise the final report and balancing device settings to include all changes; resubmit the final report and request a second final inspection.

2. If the second final inspection also fails, Owner may contact the TAB specialists' governing organization for remedial action by the governing organization under the workmanship and performance warranty. See article, Warranty.
3. If remedial action is not provided by the TAB specialists' governing organization in a timely manner, Owner may contract the services of another TAB specialist to complete the TAB Work according to the Contract Documents and deduct the cost of the services from the original TAB specialists' final payment.

D. Prepare test and inspection reports.

### 3.13 ADDITIONAL TESTS

- A. Seasonal Periods: If initial TAB procedures were not performed during near-peak summer and winter conditions, perform additional TAB during near-peak summer and winter conditions.

**END OF SECTION 23 05 93**

## **SECTION 23 80 00 – HEATING, VENTILATING AND AIR CONDITIONING**

### **PART 1 - GENERAL**

#### **1.1 SUMMARY**

- A. Section Includes:
  - 1. Roof mounted air conditioning units.
  - 2. Split system heat pump units.
  - 3. Refrigeration piping and fittings.
  - 4. Fans.
  - 5. Air inlets and outlets.
  - 6. Filters.
  - 7. Dampers.
  - 8. Ductwork.

#### **1.2 RELATED REQUIREMENTS**

- A. Drawings and general provisions of the Contract, including General and Supplementary Conditions and Division 01 Specification Sections, apply to this Section.
- B. Section 23 00 50, Basic HVAC Materials and Methods.
- C. 23 05 93, Testing, Adjusting, and Balancing for HVAC.

#### **1.3 QUALITY ASSURANCE**

- A. Design Criteria:
  - 1. All equipment and accessories to be the product of a manufacturer regularly engaged in its manufacture. All gas-fired equipment shall be UL, ETL or CSA listed.
  - 2. Supply all equipment and accessories in accordance with requirements of applicable national, state and local codes.
  - 3. All items of a given type shall be products of the same manufacturer.
  - 4. Scheduled equipment performance is minimum capacity required.
  - 5. Scheduled electrical capacity shall be considered as maximum available.
  - 6. Scheduled gas BTU input shall be considered as maximum available.

#### **1.4 ACTION SUBMITTALS**

- A. For additional requirements, refer to Section 23 00 50, Basic HVAC Materials and Methods.
- B. Product Data: Submit manufacturer's technical product data, including rated capacities of selected model clearly indicated, dimensions, weight, corner or mounting point weights, furnished specialties and accessories; and installation and start-up instructions. Product data shall include applicable product listings and standards. Refer to Section 23 00 50, Basic HVAC Material and Methods for additional requirements.
- C. Engineering Data: Submit fan curves and sound power level data for each fan unit. Data shall be at the scheduled capacity. Data shall include the name of the rating agency or independent laboratory.

## 1.5 INFORMATIONAL SUBMITTALS

- A. For additional requirements, refer to Section 23 00 50, Basic HVAC Materials and Methods.
- B. Roof Curb Data: For roof mounted equipment where combined weight of equipment unit and roof curb or rail exceeds 400 pounds, submit calculations from manufacturer for roof curbs proving compliance with the seismic requirements of the California Building Code, and ASCE 7-10. Manufacturer shall certify that roof curbs are suitable for use indicated on Drawings and in Specifications for the seismic design category indicated in structural Contract Documents. Calculations shall be stamped and signed by a State of California registered structural engineer.
- C. Economizer Fault Detection and Diagnostics (FDD) System Data: For all air-cooled unitary direct-expansion units equipped with an economizer, provide data for third-party supplied California Energy Commission certified FDD controller, documenting compliance with the requirements of California Building Energy Efficiency Standards. Provide evidence of certification.
- D. Record of pre-installation meeting.
- E. Coordinated Layouts: Submit coordinated layouts. For requirements refer to article, Coordinated Layouts, in this Section.

## 1.6 CLOSEOUT SUBMITTALS

- A. For additional requirements, refer to Section 23 00 50, Basic HVAC Materials and Methods.
- B. Maintenance Data: Submit maintenance data and parts list for each piece of equipment, control, and accessory; including "trouble-shooting guide," in Operation and Maintenance Manual.
- C. Record Drawings: Submit Record Drawings of installed ductwork, duct accessories, and outlets and inlets in accordance with requirements of Division 01.

## 1.7 COORDINATED LAYOUT

- A. Coordinated layouts are required to amplify, expand and coordinate the information contained in the Contract Documents.
- B. Provide minimum 1/4 inch equals one foot scaled coordinated layout drawings showing plan and pertinent section or elevation views of piping, ductwork, equipment, accessories, and electrical systems. Drawings shall be reproducible and work of each trade represented shall be fully coordinated with structure, other disciplines, and finished surfaces. Drawings shall be presented on a single size sheet. Coordinated layout drawings shall have title block, key plan, north arrow and sufficient grid lines to provide cross-reference to design Drawings.
  - 1. Provide a stamp or title block on each drawing with locations for signatures from all contractors involved, including but not limited to the General, HVAC, Plumbing, Fire Protection, and Electrical contractors. Include statement for signature that the contractor has reviewed the coordinated layout drawings in detail and has coordinated the work of his trade.
  - 2. Show on drawings the intended elevation of all ductwork in accordance with the following example:
    - a. B.O.D. = 9'-0"

- b. OFFSET UP 6"
  - c. B.O.D. = 9'-6"
3. Highlight, encircle or otherwise indicate deviations from the Contract Documents on the coordinated layouts. Architect will not be responsible for identifying deviations from the original Contract Documents.
- C. Since scale of contract drawings is small and all offsets and fittings are not shown, Contractor shall make allowances in bid for additional coordination time, detailing, fittings, offsets, hangers and the like to achieve a fully coordinated installation. If changes in duct size are required, equivalent area shall be maintained and the aspect ratio shall not be in excess of 2 to 1 unless approved by the engineer. Drawings shall be submitted for review prior to fabrication and installation. Drawings may be submitted in packages representing at least one quarter of the building ductwork.
- D. Check routing on all ductwork before fabricating. Report any discrepancies to Architect. No extra cost will be allowed for failure to conform to above.

## PART 2 - PRODUCTS

### 2.1 MATERIALS

- A. Insulation products, including insulation, insulation facings, jackets, adhesives, sealants and coatings shall not contain polybrominated diphenyl ethers (PBDEs) in penta, octa, or deca formulations in amounts greater than 0.1 percent (by mass).

### 2.2 GAS FIRED EQUIPMENT

- A. All gas-fired equipment shall be listed for use as a gas appliance.
- B. All units shall comply with the emissions requirements of the Air Quality Management District (AQMD) in which they are to be installed.

### 2.3 AIR CONDITIONING UNIT, ROOF-MOUNTED

- A. Provide factory assembled single packaged outdoor rooftop mounted, electrically controlled gas heating and electric cooling unit, rated in accordance with ARI Standards 210/240 or 340/360, and ETL or UL listed and labeled, classified in accordance with UL 1995. Provide refrigerant charge R-410A, all internal wiring, piping, controls, and special features required prior to field startup. Design unit to conform to the following:
- 1. California NOx emission requirements.
  - 2. ASHRAE 15.
  - 3. ASHRAE 90.1.
  - 4. Insulation, adhesive, and all materials exposed to air stream shall meet NFPA 90A requirements for flame spread and smoke generation.
  - 5. Unit casing shall be capable of withstanding 500-hour salt spray exposure per ASTM B117 (scribed specimen).
- B. Unit shall be rated in accordance with ARI sound standards 270 or 370.
- C. Unit shall be ETL or UL tested and certified in accordance with ANSI Z21.47 Standards as a total package.
- D. Roof curb shall be designed to conform to NRCA Standards.

- E. Unit shall be designed and manufactured in accordance with ISO 9001.
- F. For unit sizes applicable to Energy Star program, units shall be Energy Star qualified.
- G. Cabinet:
  - 1. Provide galvanized steel unit cabinet, bonderized and coated with a baked enamel finish.
  - 2. All airstream interior surfaces shall be insulated with a minimum 1/2 inch thick, 1.5 lb density cleanable insulation. Insulation shall be encapsulated with panel design or have sealed edges.
  - 3. Cabinet panels shall be hinged with integrated non-corrosive hinges. Provide hinged access panels for the filter, compressors, evaporator fan, and control box/ heat section areas. Each panel shall have multiple latches and handles. Each external hinged access panel shall be double-wall construction and permanently attached to the rooftop unit.
  - 4. Return air filters shall be accessible through a dedicated hinged access panel.
  - 5. Fork lift slots and rigging holes shall be provided in unit base rails. Base rails shall be minimum 16 gauge.
  - 6. Unit shall have an integral sloped condensate drain pan, providing minimum 3/4 in.-14 NPT connections for horizontal drain configuration. Provide unit with alternate vertical thru-the-bottom drain connection when furnished as standard for units sizes scheduled on Drawings. See Drawings for drain configuration. Pan shall be removable for cleaning and maintenance. All drain pans shall conform to ASHRAE 62.1 self-draining provisions.
  - 7. Unit shall have standard side and alternate field or factory installed thru-the-bottom power and control wiring connection capability. Thru-the-bottom electrical connections shall use manufacturer's approved water-tight connection method.
  - 8. Unit shall be field convertible to, or factory furnished with, horizontal air discharge, as applicable for unit sizes as scheduled on Drawings.
- H. Fans:
  - 1. Centrifugal supply air blower (evaporator fan) shall have sealed, permanently lubricated ball bearings, or rigid pillow block bearings, as supplied as standard equipment for unit sizes scheduled on Drawings. Units supplied with pillow block bearings shall be furnished with accessible lubricant fittings. Provide belt-driven double inlet fan wheel, centrifugal type with forward curved blades and adjustable sheaves. Multiple speed direct drive motors may be utilized when supplied as standard equipment for efficiency and electrical requirements as scheduled on the Drawings. Fan wheel shall be steel, with corrosion resistant finish, dynamically balanced.
  - 2. Condenser fans shall be of the direct-driven propeller type, with corrosion-resistant aluminum blades. Fans shall be dynamically balanced and discharge air upwards. Induced-draft blower shall be of the direct-driven, single inlet, forward-curved, centrifugal type, made from aluminized steel with a corrosion-resistant finish and shall be dynamically balanced.
  - 3. Induced draft fan shall be of the direct driven, single inlet, forward-curved centrifugal type. Fan wheel shall be steel, with corrosion resistant finish, dynamically balanced.
- I. Motors:
  - 1. Compressor motors shall be cooled by refrigerant gas passing through motor windings and shall have line break thermal and current overload protection.
  - 2. Evaporator fan motor shall have permanently lubricated, sealed bearings and inherent automatic-reset thermal overload protection or manual reset calibrated circuit breakers.
  - 3. Totally enclosed condenser-fan motor shall have permanently lubricated, sealed bearings, and inherent automatic-reset thermal overload protection.

4. Induced-draft motor shall have permanently lubricated sealed bearings and inherent automatic-reset thermal overload protection.
5. For single-phase fan motors sized larger than 1/12 hp and smaller than 1 hp, refer to Article, Electric Motors, in Section 23 00 50, Basic HVAC Materials and Methods.

J. Compressor:

1. Fully hermetic, scroll type with internal high-pressure and temperature protection.
2. Factory installed rubber shock mounted and internally spring mounted for vibration isolation.
3. Compressor Anti-Recycle Timer: Compressor shall be prevented from restarting for a minimum of five minutes after shutdown, with manufacturers installed compressor cycle delay.
4. Compressor shall have a five year warranty.

K. Coils:

1. Standard evaporator and condenser coils shall have aluminum plate fins mechanically bonded to seamless internally finned copper tubes with all joints brazed.
2. Units shall have face-split type evaporator coils.
3. For units with single compressor, condenser coils shall be single slab, single pass design. For dual compressor units, condenser coils shall be single slab, 2 pass design.
4. Evaporator coils shall be leak tested at minimum 150 psig, and pressure tested at minimum 450 psig.
5. Condenser coils shall be leak tested at minimum 150 psig, and pressure tested at minimum 650 psig.

L. Heating Section:

1. Induced-draft combustion type with direct-spark ignition system and redundant main gas valve with 2-stage capability on all 3-phase units.
2. Heat Exchanger:
  - a. The standard aluminized heat exchanger shall be of the tubular-section type constructed of minimum 20-gage aluminized steel. Standard heat exchanger shall have a ten year warranty.
3. Burners shall be of the in-shot type constructed of aluminum-coated steel.
4. All gas piping shall enter the unit at a single location. Gas entry shall be through side or bottom of unit. See Drawings for gas entry location. When bottom gas entry is utilized, unit shall be furnished with field installed conversion kit, arranged so that gas shut-off valve is accessible from the roof.
5. All factory-installed orifices are for operation up to 2,000 feet of altitude. For altitudes between 2,000 feet and 7,000 feet, a factory certified kit shall be furnished for field installation.
6. Units shall be suitable for use with natural gas or propane. Provide field-installed propane conversion kit as required, see schedule on Drawings.
7. The integrated gas controller board shall include gas heat operation fault notification using an LED (light-emitting diode).
8. Unit shall be equipped with anti-cycle protection with one short cycle on unit flame rollout switch or 4 continuous short cycles on the high-temperature limit switch. Fault indication shall be made using an LED.
9. The integrated gas controller board shall contain algorithms that modify evaporator-fan operation to prevent future cycling on high-temperature limit switch.
10. The LED shall be visible without removal of control box access panel.
11. Gas burner tray shall be removable for maintenance.



12. Heating section shall be insulated with foil-faced fiberglass insulation.

M. Refrigerant Components:

1. Each refrigerant circuit shall include:
  - a. Balanced port thermostatic expansion valve (TXV) with removable power element.
  - b. Solid core refrigerant filter driers with pressure ports.
  - c. Refrigerant pressure gage ports and connections on suction, discharge, and liquid lines.

N. Filter Section:

1. Standard filter section shall accommodate 2 inch deep filters. Filters shall conform to the "Air Filters" Article in this Specification Section.
2. Filter section shall use standard size filters.

O. Controls:

1. Unit shall be complete with self-contained low voltage fuse protected control circuit. Refer to Section 25 50 00, if included, and equipment schedule, sequence of operation and control diagram on Drawings for additional requirements.
2. When third party direct digital controls with an Energy Management System will be utilized, provide electro-mechanical controls with 24V thermostat interface.
3. When stand-alone thermostat operation is utilized, provide electro-mechanical controls with 24V thermostat interface or provide microprocessor controls.
4. When stand-alone thermostat operation is utilized for single-zone VAV units, provide microprocessor controls.. Units shall have factory mounted supply fan variable frequency drives.
5. When third party direct digital controls with an Energy Management System will be utilized for single zone VAV units, provide microprocessor controls with BACnet or LON interface. Units shall have factory mounted supply fan variable frequency drives.
6. Electro-mechanical controls shall include the following, as a minimum:
  - a. Service run test capability.
  - b. Provide compressor minimum run time (3 minutes) and minimum off time (5 minutes).
  - c. Economizer control.
  - d. Unit shall have 35° F low ambient cooling operation.
  - e. Time delay relay.
7. Microprocessor controls shall include the following, as a minimum:
  - a. User diagnostic interface.
  - b. Unit control with standard suction pressure transducers and condensing temperature thermistors.
  - c. Shall provide a 5° F temperature difference between cooling and heating set points to meet ASHRAE 90.1 energy standard.
  - d. Service run test capability.
  - e. Shall accept input from a CO2 sensor (indoor).
  - f. Configurable alarm light shall be provided which activates when certain types of alarms occur.
  - g. Provide compressor minimum run time (3 minutes) and minimum off time (5 minutes).
  - h. Service diagnostic mode.

- i. Economizer control.
- j. Unit shall have 0° F low ambient cooling operation.
- k. Time delay relay.

P. Safeties:

1. Unit shall incorporate a solid-state compressor lockout that provides optional reset capability at the space thermostat, should any of the following safety devices trip and shut off compressor:
  - a. Compressor lockout protection provided for either internal or external overload.
  - b. Low-pressure protection.
  - c. Freeze protection (evaporator coil).
  - d. High-pressure protection (high pressure switch or internal).
  - e. Compressor reverse rotation protection.
  - f. Loss of charge protection.
  - g. Start assist on single-phase units.
2. Supply-air sensor shall be located in the unit and detect both heating and cooling operation.
3. Induced draft heating section shall be provided with the following minimum protections:
  - a. High-temperature limit switch.
  - b. Induced-draft motor speed sensor.
  - c. Flame rollout switch.
  - d. Flame proving controls.
  - e. Redundant gas valve.
4. Phase Protection: Provide unit-mounted "SymCom," or equal, Motor Saver three phase voltage monitor, model 201A or equal, adjustable voltage range for each unit, install per manufacturer's recommendations, mount in NEMA 3R enclosure if exposed to the weather.
  - a. Units shall provide the following features:
    - 1) Low voltage fault trip and reset.
    - 2) Voltage unbalance/phasing fault trip and reset.
    - 3) High voltage fault trip and reset.
    - 4) Transient Protection (Internal).
    - 5) Automatic restart.
  - b. Provide each unit with 600V socket, "SymCom" model OT08, or equal.

Q. Operating Characteristics:

1. Unit shall be capable of starting and running at 125° F ambient outdoor temperature per maximum load criteria of ARI Standards 210 or 360.
2. Unit will operate in cooling down to an outdoor ambient temperature of 35° F.
3. Unit shall be provided with fan time delay to prevent cold air delivery in heating mode.

R. Electrical Requirements:

1. All unit power wiring shall enter unit cabinet at a single location. Both unit side and bottom power entry provisions shall be provided. Refer to Drawings schedule for thru-the-bottom power wiring requirement.

- S. Manufacturers: Subject to compliance with requirements, available manufacturers offering products that may be incorporated into the Work include the following, or equal:
1. Carrier Corporation.
  2. Trane Inc.
  3. Johnson Controls, Inc.
- T. Provide the following additional features and equipment:
1. Roof Curb: Formed galvanized steel with wood nailer strip capable of supporting entire unit weight. Provide 3 inch wide bottom flange.
  2. Provide heavy-duty 18 gauge expanded metal coil guard grille to protect all surfaces of the condensing coil. Coil guard by Micrometl, Canfab, or equal.
  3. Modulating Power Exhaust Economizer: Micrometl, Canfab, or equal. Integrated type capable of simultaneous economizer and compressor operation.
    - a. Provide self-contained outdoor rooftop system, mounted directly to the return air compartment of the HVAC packaged equipment. Provide differential dry bulb economizer control system and a factory programmed, fully programmable variable frequency drive package controlled by a differential pressure transmitter, mounted directly to the return air compartment of the HVAC packaged equipment. Design the system to continuously maintain space pressure, and provide capability of introducing up to 100 percent outdoor air.
      - 1) Economizer control system shall be certified as meeting the requirements for Fault Detection and Diagnostics (FDD) in the California Building Energy and Efficiency Standards.
    - b. Provide outside differential pressure tubing termination with hex style pneumatic filter-muffler, minimum filtration 40 microns, 53 SCFM maximum at 100 psi, as manufactured by McMaster-Carr, or equal.
    - c. Provide hinged cabinet access doors and include latches to provide a tool-less entry for servicing.
    - d. Provide door lock on the power exhaust cabinet to meet ETL safety requirements.
    - e. Outdoor air intake dampers shall be low leak not to exceed 3 percent at 1 inch wg pressure differential and include stainless steel side seal and neoprene edge seal. Arrange dampers to close upon loss of power.
    - f. Provide belt driven exhaust blowers, double inlet, forward-curved centrifugal type. Provide gravity backdraft damper at fan outlet.
    - g. Provide fully programmable factory programmed variable frequency drive (VFD) package for each fan, driven by 4 to 20 mA signal from a differential pressure transmitter. Pressure transmitters shall measure 0 - 0.1 in wg. Install room sensor tubing with sensor tube termination installed within the room.
      - 1) Where stand-alone controls are utilized, provide Belimo, or equal, damper actuator, complete with spring return and all controls, including logic module, required to make the system fully operational.
  4. Other features, accessories, and equipment scheduled on Drawings.
- U. Replenish for a period of one year without cost to the Owner all refrigerant and oil required to maintain the proper levels.
- V. Owner Training: Manufacturer shall provide two initial on-site 4-hour training sessions for Owners' maintenance personnel. Manufacturer shall provide one 4-hour follow-up training

session to be scheduled by Owner within one year of the date of the final initial training session. Training session agenda shall be as follows:

1. First session: Equipment.
2. Second session: Controls.
3. Follow-up session: Agenda by Owner.

## 2.4 SPLIT SYSTEM HEAT PUMPS

- A. General: Furnish and install split system air-to-air heat pump system, with R410A refrigerant, and complete with automatic controls. Equipment shall be shipped factory assembled, wired, tested, and ready for field connections.
- B. Quality Assurance:
  1. Unit shall be ETL or UL listed and labeled.
  2. Unit shall be manufactured in a facility registered to ISO 9001:2000.
  3. Unit shall be rated in accordance with ARI standard 210.
- C. Delivery, Storage and Handling: Follow manufacturer's recommendations.
- D. Heating/Cooling System: The total certified heating/cooling capacity shall not be less than scheduled. The compressor power input shall not exceed that of the unit specified.
- E. Indoor Section: Wall mounted, ceiling surface mounted, or ceiling recessed mounted, as indicated on Drawings.
  1. Cabinet:
    - a. Wall mounted: Molded white high strength plastic.
      - 1) Provide wall mounted unit with factory mounting plate.
    - b. Ceiling surface mounted: Molded white high strength plastic with provision for outside air duct connection.
    - c. Ceiling recessed mounted: galvanized steel with provision for outside air duct connection.
  2. Fans: Double inlet, forward curved, statically and dynamically balanced.
  3. Fan Motor: Direct drive, permanently lubricated, with two or 4 speed operation for unit size scheduled on Drawings.
    - a. For single-phase fan motors sized larger than 1/12 hp and smaller than 1 hp, refer to Article, Electric Motors, in Section 23 00 50, Basic HVAC Materials and Methods.
  4. Air Outlet: With motorized horizontal and vertical vanes.
    - a. Wall and ceiling surface mounted units: Horizontal vane shall close air outlet upon unit shut-down.
  5. Evaporator Coil: Aluminum fins mechanically bonded to copper tubes. Coils shall be pressure leak tested.
  6. Insulation: Interior surfaces exposed to the airstream shall be fully insulated.

- F. Outdoor Section:
1. Casing: Galvanized steel plate, powder coated with acrylic or polyester.
  2. Condenser Fan Grille: ABS plastic.
  3. Fan and fan motor: Direct drive, totally enclosed, propeller type, permanently lubricated, horizontal discharge.
  4. Compressor: Variable speed rotary type, with crankcase heater and accumulator. Compressor shall be capable of operating at 0 degrees F. Compressor mounted on vibration isolator pads.
  5. Coil: Aluminum fins mechanically bonded to copper tubes. Coils shall be pressure leak tested. Provide coil with integral metal guard.
- G. Controls: Hard wired, microprocessor based, wall mounted controller with LCD display shall provide the following functions, as a minimum:
1. 7-day programmable timer.
  2. Test and check functions.
  3. Diagnostic functions.
  4. Fan speed adjustment.
  5. Temperature adjustment.
  6. Automatic restart.
  7. Mode selection, including heat/auto/cool/dry/fan.
    - a. Provide lockable enclosure for wall mounted controller.
- H. Safeties: Shall include the following, as a minimum:
1. Five minute compressor anti-recycle timer.
  2. High pressure protection.
  3. Current and temperature sensing motor overload protection.
- I. Filters: Provide manufacturers washable filters for indoor unit. Provide sufficient filters for four complete changes for each unit.
- J. Service Access: All components, wiring, and inspection areas shall be completely accessible through removable panels.
- K. Refrigerant Piping:
1. Provide factory pre-charged and sealed line set piping, length to suit the location of equipment. Tubing sizes shall be in accordance with manufacturers written instructions.
  2. Provide refrigeration piping in accordance with Article, Refrigerant Piping, in this Section.
- L. Manufacturers: Subject to compliance with requirements, available manufacturers offering products that may be incorporated into the Work include the following, or equal:
1. Mitsubishi Electric Corporation.
  2. Carrier Corporation.
  3. Sanyo Electric Co., Ltd.
- M. Owner Training: Manufacturer shall provide one on-site 2-hour training session for Owners' maintenance personnel.

## 2.5 REFRIGERATION PIPE AND FITTINGS

- A. Refrigeration gas and liquid piping shall be type ACR hard drawn copper tubing, cleaned and capped in accordance with ASTM B280, with wrought copper fittings. All joints shall be brazed with Sil-fos under nitrogen purge. Relief valve discharge piping shall be full size of relief discharge port.
  - 1. Manufactured, pre-charged and pre-insulated refrigerant line-set refrigerant piping may be utilized at Contractor's discretion.
- B. Refrigeration Piping Specialties: Furnish and install Superior, Sporlan, Alco, Henry, or equal, stop valves, solenoid valves, adjustable thermal expansion valves, sight glass, flexible connection, charging valve, and drier with valve bypass in the liquid lines and Superior DFN shell and cartridge suction line filter sized 2-1/2 times tonnage.
  - 1. Install only those refrigeration piping specialties recommended by manufacturer of specific installed equipment.

## 2.6 FANS

- A. All fans shall be Air Moving and Control Association Inc. (AMCA) labeled.
- B. Provide self-aligning, enclosed ball bearings, accessible for lubrication unless specified otherwise.
- C. Provide variable speed switch for all direct drive fans.
- D. Roof Mounted:
  - 1. Direct or V-belt Drive: Provide one-piece heavy-duty ventilator housings, one piece heavy gauge spun aluminum construction, with weatherproof assembly and integral weather shield. Mount ventilators on curbs furnished by the fan manufacturer. Install with fan assembly level.
  - 2. Fan wheels shall be centrifugal design, statically and dynamically balanced. Tip speed, rpm and motor horsepower shall not exceed listing in manufacturer's catalog for unit specified.
  - 3. Fans shall have integral factory formed base and one piece spinning without welding. Housings shall be provided with wiring channel and are to be of the direct discharge design. Motor and fan assembly shall be on vibration isolating mounts. Fans shall have capacity, speeds and motor sizes as shown.
  - 4. Provide the following accessories:
    - a. Gravity backdraft dampers.
    - b. Aluminum bird screen with a minimum of 85 percent free area.
    - c. Adjustable motor pulley.
- E. Fan Drives:
  - 1. Drive Design: The design horsepower rating of each drive shall be at least 1.5 times, single belt drives 2 times, the nameplate rating of the motor with proper allowances for sheave diameters, speed ratio, arcs of contact and belt length.
  - 2. Provide variable speed drives, Dayco, Browning, Woods, or equal. Allow for replacement of fan and motor drives and belts as required to suit the balance requirements of the project.

3. Select variable speed drives to allow an increase or decrease of minimum of ten percent of design fan speed.

F. Motors:

1. Motors of 25 HP and less shall have adjustable pitch sheaves; sheaves on motors above 25 HP may be non-adjustable. Change, at no extra cost to Owner, the non-adjustable sheaves to obtain desired air quantities.
2. For single-phase fan motors sized larger than 1/12 hp and smaller than 1 hp, refer to Article, Electric Motors, in Section 23 00 50, Basic HVAC Materials and Methods.

G. Sheaves: Sheaves shall be cast or fabricated, bored to size or bushed with fully split tapered bushings to fit properly on the shafts. All sheaves shall be secured with keys and set screws.

H. Belts:

1. All belts shall be furnished in matched sets.
2. Provide a minimum of two belts for all drives with motors 5 horsepower motors and larger.
3. Belts shall be within 1 degree 30 minutes of true alignment in all cases.

I. Manufacturers: Subject to compliance with requirements, available manufacturers offering products that may be incorporated into the Work include the following, or equal:

1. Greenheck Fan Corporation.
2. Loren Cook Company.
3. PennBarry.
4. American Coolair Corporation.

J. Owner Training: Manufacturer shall provide one on-site 1-hour training session for Owners' maintenance personnel.

## 2.7 AIR INLETS AND OUTLETS

- A. Except as otherwise indicated, provide manufacturer's standard outlets and inlets where shown; of size, shape, capacity and type indicated; constructed of materials and components as indicated, and as required for complete installation.
- B. Ceiling, wall or floor Compatibility: Provide outlets with border styles that are compatible with adjacent ceiling, wall or floor systems, and that are specifically manufactured to fit into ceiling, wall or floor module with accurate fit and adequate support. Refer to general construction drawings and specifications for types of ceiling systems that will contain each type of air outlet and inlet.
- C. Refer to Schedule on Mechanical Drawings for details of inlets and outlets to be used.

## 2.8 AIR FILTERS

- A. Provide MERV 8 disposable pleated media type. Refer to specific equipment Articles for filter depth and for exceptions to this specification. Filters shall conform to the following:
  1. Standards:
    - a. ASHRAE Standard 52.2-2007.
    - b. Underwriters Laboratories: U.L. 900, Class 2.

2. Construction:
    - a. Media: Synthetic or cotton-synthetic blend with radial pleats.
    - b. Media Frame: High wet-strength beverage board.
    - c. Media Support: Welded wire or expanded metal grid bonded to air leaving side of the media.
  3. Performance: 2" deep filter shall have a maximum initial air resistance of 0.31 inches w.g.
- B. Manufacturers: Subject to compliance with requirements, available manufacturers offering products that may be incorporated into the Work include the following, or equal:
1. Camfil Farr, Inc., model 30/30.
  2. Flanders Corporation, model 40 LPD.
- C. Temporary (Construction Period) Filters:
1. Install new temporary filters in all units that have filter systems installed. Temporary filters shall match the permanent filters that are specified for the units. Replace filters as needed, in accordance with manufacturer's directions, in order to provide protection for the unit prior to occupancy by the Owner.
  2. If air handling units are operated during construction of the project, install temporary filters directly over each return air inlet. Filters shall match the permanent filters that are specified for the units. Select size of filter to completely cover the frame of the return air inlet, and tape filters firmly in place to eliminate any construction debris from entering the duct system or unit. Remove the temporary filters upon completion of the work, and repair all damaged paintwork.
- D. Spare Filters:
1. Furnish two new, complete sets of filter cartridges for each filter bank on completion and acceptance of the work. Install one set of filters in units (prior to final air balance) and leave the remaining filters in location designated by the Owner.

## 2.9 DAMPERS

- A. Backdraft Dampers: Ruskin CBD2, counterbalanced, Nailer Industries, or equal.
- B. Manual Air and Balance Dampers: Provide dampers of single blade type or multi-blade type constructed in accordance with SMACNA, "HVAC Duct Construction Standards," except as noted herein.
1. Rectangular Ductwork:
    - a. Single damper blades may be used in ducts up to 10 inches in height. Dampers shall be 16 gauge minimum. Provide self-locking regulators, equal to Ventlok 641. Provide end bearings equal to Ventlok 607 at each damper. Provide continuous solid 3/8 inch square shafts.
    - b. Multiple blade dampers shall be equal to Ruskin CD35 Standard Control Damper. Maximum width for multiple damper blades for use in rectangular duct shall not exceed 6 inches.
    - c. Where duct velocity may be expected to exceed 1500 fpm, provide Ruskin CD-50, or equal, low leakage dampers with airfoil blades.



2. Round Ductwork:
  - a. Single damper blades may be used in ducts up to 12 inches in diameter. Provide multiple blade opposed blade dampers, with connected linkage, for ductwork larger than 12 inches in diameter.
  - b. Damper blades for round ductwork shall be 20 gauge steel for ducts up to 12 inches diameter and 16 gauge steel for dampers larger than 12 inches damper. Provide self-locking regulators, equal to Ventlok 641, Durodyne, or equal for operation of dampers. Provide end bearings equal to Ventlok 607 and provide continuous solid 3/8 inch square shafts.
3. Where ductwork is externally insulated, provide self-locking regulators equal to Ventlok 644, Durodyne, or equal for rectangular ductwork, and Ventlok 637, Durodyne, or equal for round ducts.

## 2.10 DUCTWORK

- A. Construct and install all sheet metal ductwork in accordance with the California Mechanical Code for 2 inches static pressure for supply air, and 2 inches minimum for return and exhaust air unless otherwise noted on Drawings.
  1. Where not in conflict with the California Mechanical Code, construct and install all sheet metal ductwork in accordance with SMACNA HVAC Duct Construction Standards (Metal and Flexible). Where applicable for HVAC work, construct and install sheet metal work in accordance with SMACNA Architectural Sheet Metal Manual.
  2. Provide variations in duct size, and additional duct fittings as required to clear obstructions and maintain clearances as approved by the Architect at no extra cost to the Owner.
  3. Gauges, joints and bracing shall be in accordance with the California Mechanical Code.
  4. Provide beading or cross breaking for all ductwork inside building. Provide cross breaking for ductwork exposed to weather.
  5. At the contractor's option, ductwork may be fabricated using the Ductmate, Nexus, Quickduct, Transverse Duct Connection (TDC), Pyramid-Loc duct connection systems, or equal. Fabricate in strict conformance with manufacturer's written installation instructions and in accordance with California Mechanical Code.
    - a. Seal flanged ends with pressure sensitive high density, closed cell neoprene or polyethylene tape gasket, Thermo 440, or equal.
    - b. Provide metal clips for duct connections, except at breakaway connections for fire dampers and fire smoke dampers. Provide corner clips at each corner of duct, through bolted, at all locations except at breakaway connections for fire dampers and fire smoke dampers. Where used on locations exposed to weather, provide continuous metal clip at top and sides of duct, with 1 inch overhang for top side.
- B. Design and installation standards:
  1. SMACNA Compliance: Comply with applicable portions of Sheet Metal and Air Conditioning Contractor's National Association (SMACNA) for all work in this section.
  2. NFPA Compliance: Comply with ANSI/NFPA 90A, "Standard for the Installation of Air Conditioning and Ventilating Systems," and ANSI/NFPA 90B, "Standard for the Installation of Warm Air Heating and Air Conditioning Systems."
  3. California Mechanical Code.
- C. Fabricate all ductwork with sheet metal. Fiberglass ductwork will not be accepted for use on this project.

- D. Duct sizes indicated are external sizes.
- E. Galvanized Sheet Steel: Lock-forming quality, ASTM A924 and ASTM A653, Coating Designation G 90. Provide mill phosphatized finish for exposed surfaces of ducts exposed to view.
1. Provide mill certification for galvanized material at request of the Project Inspector.
- F. Duct Sealants:
1. Sealant shall have a VOC content of 250 g/L or less.
  2. Sealant shall comply with testing and product requirements of South Coast Air Quality Management District, Rule 1168.
  3. Provide one part, non-sag, synthetic latex sealant, formulated with a minimum of 68 percent solids. Sealant shall comply with ASTM E84, Surface Burning Characteristics.
    - a. Manufacturers: Subject to compliance with requirements, available manufacturers offering products that may be incorporated into the Work include the following, or equal:
      - 1) Design Polymerics, model DP1010.
      - 2) Polymer Adhesive Sealant Systems Inc, model Airseal #11.
      - 3) McGill Airseal, LLC.
- G. Provide sheet metal angle frame at all duct penetrations to wall, floor, roof, or ceiling.
- H. Duct Support Materials: Except as otherwise indicated, provide hot-dipped galvanized steel fasteners, anchors, straps, trim, and angles for support of ductwork.
- I. Rectangular Duct Fabrication:
1. Shop fabricate ductwork of gauges and reinforcement complying with the more stringent of the following standards, except as noted herein.
    - a. SMACNA HVAC Duct Construction Standards
    - b. California Mechanical Code
  2. Fabricate ducts for 2 inch pressure class with minimum duct gauges and reinforcement as follows, except as otherwise noted:

<u>Table A</u>		
<u>Duct Dimension</u>	<u>Minimum Gauge</u>	<u>Joint Reinforcement Per CMC</u>
Through 12"	26	Not Required
13" through 18"	24	Not Required
19" through 30"	24	C/4
31" through 42"	22	E/4
43" through 54"	22	F/2

55" through 60"	20	G/4
61" through 84"	20	I/2
85" through 96"	20	J/2
Over 96"	18	K/2

3. Fabricate duct fittings to match adjoining ducts and to comply with duct requirements as applicable to fittings. Except as otherwise indicated, fabricate elbows with center-line radius equal to 1.5 times associated duct width. Fabricate to include single thickness turning vane in elbows where space does not permit the above radius or where square elbows are shown. Limit angular tapers to 30 degrees for contracting tapers and 20 degrees for expanding tapers. Turning vanes shall be E-Z Rail II, Durodyne, or equal.
4. Fabricate round supply connections at rectangular, plenum type fittings using spin-in type fittings, complete with extractor and volume control damper. Refer to Paragraph "DAMPERS" for damper requirements.
5. Provide drive slip or equivalent flat seams for ducts exposed in the conditioned space or where necessary due to space limitations. On ducts with flat seams, provide standard reinforcing on inside of duct. Duct connection to outlet on exposed duct shall be full size of outer perimeter of outlet flange.
6. Ducts exposed in the conditioned space shall be free of dents and blemishes and be mounted tight against adjacent surface with flat hangers. Remove all fabrication labels from ductwork.
7. Provide 20 gauge minimum for ductwork exposed within occupied spaces.

J. Rectangular Internally Insulated Duct Fabrication:

1. Provide internal duct lining where indicated on the Drawings, with a minimum of 10'-0" length in each direction from the fan, fan casing, or unit casing. Line all transfer ducts.
  - a. Where ductwork is within the building insulation envelope, lining shall be 1" thick, 1-1/2 pound density, with R-value of 4.2 minimum.
  - b. Ducts exposed in the conditioned space shall be free of dents and blemishes and be mounted tight against adjacent surface with flat hangers. Remove all fabrication labels from ductwork.
  - c. Where installed exposed in the conditioned space, duct shall be minimum 20 gauge with 1 inch insulation layer (minimum R-value – R-4.2).
  - d. Cement duct liner in place with nonflammable, non-hardening duct adhesive. Seal all raw edges of insulation inside ductwork with adhesive, including longitudinal liner edges.
  - e. Provide metal nosing at all locations where liner is preceded by unlined metal.
  - f. Provide sheet metal weld pins and washers or clinch pins and washers on all ductwork on 12 inch intervals with the first row within 3 inches of the leading edge of each piece of insulation and within 4 inches of corners. No use of adhesive mounted pins will be considered.
    - 1) Install clinched pin fasteners with properly adjusted automatic fastening equipment. Manual installation will not be considered.
    - 2) Install weld pins with properly adjusted automatic fastening equipment. Installation shall not damage the galvanized coating on the outside of the duct.

- g. All ductwork, adhesives, lining, sealant, flex duct and the like shall have a flame spread of 25 or less and developed smoke rating of 50 or less when tested in accordance with one of the following test methods: NFPA 255, ASTM E84, or UL 723.
- h. Manufacturers: Subject to compliance with requirements, available manufacturers offering products that may be incorporated into the Work include the following, or equal:

<u>Manufacturer:</u>	<u>Product:</u>
Johns Manville	Duct Liner PM
CertainTeed Corporation	ToughGard
Fosters Adhesive	85-62
Swifts Adhesive	7336

K. Round and Oval Ductwork Fabrication:

1. Round and oval duct and fittings shall be spiral lockseam or longitudinal seam as indicated in table below. Provide couplings to join each length of duct.
  - a. At contractors' option, round or oval ductwork may be utilized in place of rectangular ductwork shown on Drawings, provided available space allows installation of round or oval ductwork without compromising space required for installation of products and systems of other trades.
    - 1) Round or oval ductwork utilized in place of rectangular ductwork shown on Drawings shall be sized to have a static pressure loss equivalent to rectangular duct shown on Drawings.
    - 2) Unlined round or oval duct shall not be utilized in place of rectangular internally lined ductwork shown on Drawings.
2. Fabricate duct fittings to match adjoining ducts and to comply with duct requirements as applicable to fittings. Except as otherwise indicated, fabricate elbows with center-line radius equal to 1.5 times associated duct width. Provide two-piece, die-stamped, 45-degree to 90-degree elbows for sizes up to 12 inches; five-piece, 90-degree elbows for sizes 12 inches and above; conical tees; and conical laterals. All reducers shall be placed after a tap has been made on the duct main. Reducers shall be long-taper style.
3. Round Ductwork: Construct of galvanized sheet steel complying with ANSI/ASTM A 653 by the following methods and in minimum gauges listed.

<u>Diameter</u>	<u>Minimum Gauge</u>	<u>Method of Manufacture</u>
Up to 14"	26	Spiral Lockseam
15" to 23"	24	Spiral Lockseam

24" to 36"	22	Spiral Lockseam
37" to 50"	20	Spiral Lockseam
51" to 60"	18	Spiral Lockseam
Over 60"	14	Longitudinal Seam

4. Provide locked seams for spiral duct; fusion welded butt seam for longitudinal seam duct.
5. Fittings and Couplings: Construct of minimum gauges listed. Provide continuous welds along seams at exposed ducts. Provide spot weld bonded seams at concealed ducts.

<u>Diameter</u>	<u>Minimum Gauge</u>
3" to 36"	20
38" to 50"	18
Over 50"	16

6. Ducts exposed in the conditioned space shall be free of dents and blemishes and be mounted tight against adjacent surface with flat hangers. Remove all fabrication labels from ductwork.
7. Provide 20 gauge minimum for ductwork exposed within occupied spaces.

L. Duct Access Doors:

1. Duct Access: Provide hinged access door in rectangular ducts for access to fire dampers, control equipment, etc. Access door size shall be duct diameter wide by duct diameter high for all ducts under 24 inches. Ducts over 24 inches in diameter shall have 24-inch by 18-inch access doors. Minimum size access doors shall be 6 inches by 6 inches.
2. Provide hinged style access doors for round ductwork, NCA Manufacturing, Inc., Model AD-RD-87, Pottorff Series 60, or equal. Access doors shall be 16 gauge galvanized steel with continuous piano hinge. Locks shall be plated steel strike and catch. Provide 1" x 3/8" Polyethylene "Perma Stik" gasket all around door.

M. Flexible Air Ducts:

1. Provide exterior reinforced laminated vapor barrier, fiberglass insulation, encapsulated spring wire helix, and acoustical interior liner. Individual lengths of flexible ducts shall contain factory fabricated steel connection collars.
  - a. Manufacturers: Subject to compliance with requirements, available manufacturers offering products that may be incorporated into the Work include the following, or equal:
    - 1) C.A. Schroeder, Inc., Silent Flex II, model SF-181M.
    - 2) ThermaFlex model M-KE.

2. Factory made air ducts shall be approved for the use intended and shall conform to the requirements of UL 181 and NFPA 90A. Each portion of a factory-made air duct system shall be identified by the manufacturer with a label or other suitable identification indicating compliance with UL 181, Class 1. Ducts shall be UL listed Class 1, maximum 25/50 smoke and flame spread and shall be installed in accordance with the terms of their listing and the requirements of SMACNA HVAC Duct Construction Standards (Metal and Flexible). Factory-made air ducts shall have the following minimum R-values: R-6.0 for ductwork installed within the building insulation envelope, R-8.0 for ductwork installed outside the building insulation envelope.
3. Flexible ductwork shall be maximum of 5 feet long, and shall be extended to the fullest possible length, in order to minimize pressure drop in the duct.
4. Flexible ducts shall be selected for minimum of 6 inch positive static pressure and minimum of 1 inch negative static pressure.
5. Duct Access Panels:
  - a. Provide duct access panel assembly of the same material and gauge used for the duct. Duct access panels shall conform to the following:
    - 1) Fasteners: Black steel or stainless steel to match material used for the duct. Panel fasteners shall not penetrate duct wall.
    - 2) Gasket: Comply with NFPA 96, grease-tight, high temperature ceramic fiber, rated for minimum 1500 °F.

## PART 3 - EXECUTION

### 3.1 ROOF MOUNTED EQUIPMENT

- A. Mount and anchor equipment in strict compliance with Drawings details. Alternate anchorage methods will not be considered for roof mounted equipment.
- B. Examine rough-in for roof mounted equipment to verify actual locations of piping and duct connections prior to final equipment installation.
- C. Verify that piping to be installed adjacent to roof mounted equipment allows service and maintenance.
- D. Verify that gas piping will be installed with sufficient clearance for burner removal and service.
- E. Install ducts to termination at top of roof curb and install heavy duty rubber gaskets on supply and return openings and on full perimeter of curb, or as required for an airtight installation, prior to setting unit on curb.
- F. Cover roof inside each roof mounted air conditioning unit, heat pump unit, and heating and ventilating unit roof curb with 2 inch thick, 3 pound density fiberglass insulation board.
- G. Connect supply and return air ducts to horizontal discharge roof mounted equipment with flexible duct connectors specified elsewhere in these Specifications.
- H. Remove roof decking only as required for passage of ducts. Do not cut out decking under entire roof curb.

### 3.2 INSTALLATION OF SPLIT SYSTEM AC, HEAT PUMP, AND VRF SYSTEMS

- A. General:

1. Install units level and plumb.
2. Install evaporator-fan components as detailed on Drawings.
3. Install ground or roof- mounted condensing units as detailed on Drawings.
4. Install seismic restraints as required by applicable codes. Refer to Article, Submittals, in Section 23 00 50, Basic HVAC Materials and Methods, for delegated design requirements for seismic restraints.
5. Install and connect refrigerant piping as detailed in unit manufacturers' literature. Install piping to allow access to unit.
6. Install cooling coil condensate primary drain pan piping, and overflow, if provided, and run to nearest code-compliant receptacle, or as indicated on Drawings. Install secondary drain pan for units installed over permanent and suspended-tile ceilings. Install secondary drain pan piping and terminate 1/2 inch below ceiling, with escutcheon, in a readily visible location or as shown on Drawings.
7. Install air filters at each indoor unit. Refer to Drawings schedule, and Article, Air Filters, in this Section, for filter requirements for ducted, above-ceiling units incorporating mixing boxes.
8. Duct Connections: Duct installation requirements are specified in Article, Ductwork, in this Section. Drawings indicate the general arrangement of ducts. Connect supply and return ducts to split-system air-conditioning units with flexible duct connectors. Flexible duct connectors are specified in Article, Ductwork, in this Section.

### 3.3 REFRIGERANT PIPING INSTALLATION

#### A. General:

1. Install refrigerant piping according to ASHRAE 15. Install and connect refrigerant piping as detailed in unit manufacturers' literature. Install piping to allow access to unit.
2. Install piping straight and free of kinks, restrictions or traps.
3. Install piping as short and direct as possible, with a minimum number of joints, elbows, and fittings.
4. Slope horizontal suction piping 1 inch/10 feet towards compressor.
5. Install fittings for changes in direction and branch connections.
6. Insulate refrigerant piping, including liquid and hot gas pipes when required by system manufacturer, and including headers, branches, and other components as detailed in unit manufacturers' literature. Refer to Article, Insulation Work, in Section 23 00 50, Basic HVAC Materials and Methods.

#### B. Factory Pre-charged and sealed line set piping:

1. Keep the entire system clean and dry during installation.
2. All tubing shall be evacuated and sealed at the factory. The seal must not be broken until ready for assembly.
3. If there is any evidence of dust, moisture, or corrosion, the tubing must be cleaned out by drawing a swab soaked with methyl alcohol through the tubing as many times as necessary to thoroughly clean the tubing.
4. Where line set piping is used, enclose in iron or steel piping and fittings or in EMT conduit.

### 3.4 INSTALLATION OF FANS

- A. Provide access doors for fans or motors mounted in ductwork.
- B. Mount all fans as detailed on Drawings and in compliance with CBC standards.
- C. Fan motors mounted in air-stream to be totally enclosed.

- D. Completely line supply, return or exhaust fan cabinets with 1 inch thick, 3/4 pound density acoustic insulation securely cemented in place.
- E. Roof fans shall be mounted level.
- F. Provide heavy-duty rubber gasket between exhaust fan mounting flange and roof curb, or as required for an airtight installation.

### 3.5 AIR INLETS AND OUTLETS

- A. Provide all air inlets and outlets with gaskets and install so that there will be no streaking of the walls or ceilings due to leakage. Duct connection to outlet on exposed duct shall be full size of outer perimeter of outlet flange.
- B. Unless otherwise indicated on Drawings, provide rectangular plenum on top of each diffuser and ceiling return for connection to ductwork. Line plenum with internal insulation as indicated for lined ductwork. Size plenum to allow full opening into air terminal.
- C. Ceiling-mounted air terminals or services installed in T-Bar type ceiling systems shall be positively attached to the ceiling suspension main runners or to cross runners with the same carrying capacity as the main runners.
  - 1. Terminals or services weighing not more than 56 pounds shall have two No. 12 gauge hangers connected from the terminal or service to the structure above. These wires may be slack.
  - 2. Support terminals or services weighing more than 56 pounds directly from the structure above by approved hangers. Provide 4 taut 12 gauge wires each, attached to the fixture and to the structure above. The 4 taut 12 gauge wires, including their attachment to the structure above must be capable of supporting 4 times the weight of the unit.
  - 3. Secure air inlets and outlets to main runners of ceiling suspension system with two #8 sheet metal screws at opposing corners.
- D. Furnish all air inlets and outlets with a baked prime coat unless otherwise noted. Provide off-white baked enamel finish on ceiling-mounted air inlets and outlets. Paint exposed mounting screws to match the material being secured.
- E. Air inlets and outlets shall match all qualities of these specified including appearance, throw, noise level, adjustability, etc.

### 3.6 TEMPORARY FILTERS

- A. Provide temporary filters for all fans that are operated during construction; after all construction dirt has been removed from the building install new filters at no additional cost to the Owner. In addition to temporary filters at filter location, provide temporary filters on all duct openings which will operate under a negative pressure.
  - 1. Filters used for temporary operation shall be the same as permanent filters for the application. Filters used for duct openings may be 1 inch thick pleated media disposable type.

### 3.7 DAMPERS

- A. All dampers automatically controlled by damper motors are specified under "Temperature Control System" except those specified with items of equipment.



- B. Provide opposed blade manual air dampers at each branch duct connection and at locations indicated on the drawings and where necessary to control air flow for balancing system. Provide an opposed blade balancing damper in each zone supply duct. Provide an access panel or Ventlok flush type damper regulator on ceiling or wall for each concealed damper.
- C. Provide 18 inch x 12 inch minimum hinged access doors in ductwork and furring for easy access to each fire damper; insulated access doors in insulated ducts. Label access doors with 1/2 inch high red letters.
  - 1. Provide Ventlok Series 100, Durodyne, or equal access doors with hardware for convenient access to all automatic dampers and other components of the system, insulated type in insulated ducts. Provide Ventlok #202 for light duty up to 2 inch thick doors, #260 heavy-duty up to 2 inch thick doors and #310 heavy-duty for greater than 2 inch thick doors. Provide #260 hinges on all hinged and personnel access doors; include gasketing.

3.8 INSTALLATION OF DUCTWORK

- A. Assemble and install ductwork in accordance with recognized industry practices which will achieve air tight and noiseless (no objectionable noise) systems capable of performing each indicated service. Install each run with minimum of joints. Align ductwork accurately at connections within 1/8 inch misalignment tolerance and with internal surfaces smooth. Support ducts rigidly with suitable ties, braces, hangers, and anchors of type which will hold ducts true to shape and to prevent buckling. Where possible, install ductwork to clear construction by 1/4 inch minimum, except at air inlets and outlets. Where ductwork will not clear construction, secure duct firmly to eliminate noise in the system.
- B. Duct Joints: Install duct sealers, pop rivets or sheet metal screws at each fitting and joint. Duct sealer shall be fire retardant. Sheet metal screw for joints shall be minimum #10 size galvanized.
- C. Upper connection of support to wood structure shall be with wood screws or lag screws in shear fastened in the upper one half of the wood structural member. Fasteners shall conform to the following schedule:

For ducts with P/2=30"	#10 x 1-1/2" wood screw
For ducts with P/2=72"	1/4"x 1-1/2" lag screw
For ducts with P/2 over 73"	3/8"x 1-1/2" lag screw

- D. Upper connection in tension to wood shall not be used unless absolutely necessary. Where deemed necessary the contractor shall submit calculations to show the size fastener and penetration required to support loads in tension from wood in accordance with the following schedule:

For ducts with P/2=30"	260 pounds per hanger
For ducts with P/2=72"	320 pounds per hanger
For ducts with P/2=96"	460 pounds per hanger
For duct with P/2 larger than 120"	NOT ALLOWED

- E. Upper connection to manufactured truss construction must comply with truss manufacturers published requirements and Structural Engineers requirements.

- F. Where ducts pass through interior partitions and exterior walls, conceal space between construction opening and duct or duct plus insulation with sheet metal flanges of same gauge as duct. Overlap opening on four sides by at least 1-1/2 inches.
- G. Support ductwork in manner complying with SMACNA "HVAC Duct Construction Standards," hangers and supports sections. Where special hanging of ductwork is detailed or shown on Drawings, Drawings shall be followed. Angles shall be attached to overhead construction in a manner so as to allow a minimum of 2 inches of movement in all directions with no bending or sagging of the angle.
  - 1. Except where modified in individual paragraphs of this Section, provide hanger support with minimum 18 gauge straps, 1 inch wide. Fold duct strap over at bottom of duct.
  - 2. Install duct supports to rectangular ducts with sheet metal screws. Provide one screw at top of duct and one screw into strap at bottom of duct.
- H. Installation of Flexible Ductwork:
  - 1. Provide flexible ducts with supports at 30 inch centers with 2 inch wide, 26 gauge steel hanger collar attached to the structure with an approved duct hanger. Installation shall minimize sharp radius turns or offsets.
    - a. Supports shall be in accordance with SMACNA HVAC Duct Construction Standards (Metal and Flexible).
    - b. Make bends to maintain R/W-1.5.
  - 2. Make connections to rigid duct and units with Panduit style draw band at inner liner material, and a second draw band over the outer vapor barrier material.
  - 3. Make connection to duct with spin-in fittings, with air scoop and balance damper.

3.9 DUCTWORK SEALING AND LEAK TESTING

- A. All ductwork shall receive a Class A seal.
- B. Seal airtight all joints and seams, including standing seams and manufactured joints and seams, of all supply, return and exhaust ducts except those exposed in conditioned space.
- C. Leakage Classes:

Pressure Class	Leakage Class	
	Round Duct	Rectangular Duct
2"W.G. or less	8	16

- D. All duct systems (supply, return, outside air intake, and exhaust), except those identified on compliance forms on Drawings as requiring Acceptance Testing per the requirements of the California Energy Code, shall be tested in accordance with the requirements of SMACNA's "HVAC Air Duct Leakage Test Manual." Test pressure shall be equal to the pressure class of the duct. For additional duct leak testing requirements, refer to Section 23 00 50, "Basic HVAC Materials and Methods," Article, "Acceptance Requirements."

3.10 TEMPERATURE CONTROL SYSTEM

- A. Provide thermostats where indicated on drawings. All wiring shall be in conduit. Provide all relays, transformers and the like to render the control system complete and fully operable. All control conduit to be rigid steel type.

### 3.11 EQUIPMENT START-UP

- A. Initial start-up of the systems and pumps shall be under the direct supervision of the Contractor.
- B. Equipment start-up shall not be performed until the piping systems have been flushed and treated and the initial water flow balance has been completed.
- C. It shall be the responsibility of the Contractor to assemble and supervise a start-up team consisting of controls contractor, start-up technician, and test and balance contractor; all to work in concert to assure that the systems are started, balanced, and operate in accordance with the design.
- D. After start-up is complete, instruct the Owner's personnel in the operation and maintenance of the systems. Obtain from the Owner's representative a signed memo certifying that instruction has been received.
- E. For additional requirements, refer to article, Check, Test and Start Requirements, in Section 23 00 50, Basic HVAC Materials and Methods.

### 3.12 TESTING AND BALANCING

- A. For testing and balancing requirements, refer to Section 23 05 93, Testing and Balancing for HVAC.

### 3.13 CLEANING AND PROTECTION

- A. As each duct section is installed, clean interior of ductwork of dust and debris. Clean external surfaces of foreign substances that might cause corrosive deterioration of metal or where ductwork is to be painted.
- B. Strip protective paper from stainless steel ductwork surfaces, and repair finish wherever it has been damaged.
- C. Temporary Closure: At ends of ducts that are not connected to equipment or air distribution devices at time of ductwork installation, provide temporary closure of polyethylene film or other covering that will prevent entrance of dust and debris until connections are to be completed.
- D. As each internally lined duct section is installed, check internal lining for small cuts, tears, or abrasions. Repair all damage with fire retardant adhesive.

### 3.14 EQUIPMENT MOUNTING

- A. Mount and anchor equipment in strict compliance with Drawings details. Alternate anchorage methods will not be considered for roof mounted equipment.

**END OF SECTION 23 80 00**

## SECTION 26 00 10 - BASIC ELECTRICAL REQUIREMENTS

### PART 1 - General

#### 1.1 SUMMARY

A. Table of Contents, Division 26 - Electrical:

<u>SECTION NO.</u>	<u>SECTION TITLE</u>
26 00 10	BASIC ELECTRICAL REQUIREMENTS
26 00 90	ELECTRICAL DEMOLITION
26 05 19	BUILDING WIRE AND CABLE
26 05 26	GROUNDING AND BONDING
26 05 29	ELECTRICAL HANGERS AND SUPPORTS
26 05 31	CONDUIT
26 05 33	BOXES
26 05 53	ELECTRICAL IDENTIFICATION
26 09 26	LOW-VOLTAGE LIGHTING CONTROL
26 24 16	PANELBOARDS
26 27 26	WIRING DEVICES
26 28 16	OVERCURRENT PROTECTIVE DEVICES
26 28 19	DISCONNECT SWITCHES
26 50 00	LIGHTING
26 61 13	FIRE ALARM SYSTEM

B. Work included: This Section includes general administrative and procedural requirements for Division 26. The following administrative and procedural requirements are included in this Section to supplement the requirements specified in Division 01.

1. Quality assurance.
2. Definition of terms.
3. Submittals.
4. Coordination.
5. Record documents.
6. Operation and maintenance manuals.
7. Rough-in.
8. Electrical installation.
9. Cutting, patching, painting and sealing.
10. Field quality control.
11. Cleaning.
12. Project closeout.

C. Related Work: Consult all other Sections, determine the extent and character of related Work and properly coordinate Work specified herein with that specified elsewhere to produce a complete and operable installation.

1. General and supplementary conditions: Drawings and general provisions of Contract and Division 01 of the Specifications, apply to all Division 26 Sections.
2. Selective demolition: Nondestructive removal of materials and equipment for reuse or salvage as indicated. Also dismantling electrical materials and equipment made obsolete by these installations.
3. Miscellaneous metal Work: Include fittings, brackets, backing, supports, rods, welding and pipe as required for support and bracing of raceways, lighting fixtures, panelboards, distribution boards, switchboards, motor control centers, etc.

4. Miscellaneous lumber and framing Work: Include wood grounds, nailers, blocking, fasteners and anchorage for support of electrical materials and equipment.
  5. Moisture protection and smoke barrier penetrations: Include membrane clamps, sheet metal flashing, counter flashing, caulking and sealant as required for waterproofing of conduit penetrations and sealing penetrations in or through fire walls, floors, ceiling slabs and foundation walls. All penetrations through vapor barriers at slabs on grade shall be taped and made vaportight.
  6. Access panels and doors: Required in walls, ceilings and floors to provide access to electrical devices and equipment. Refer to Division 08, Access Doors also, Division 05, Metals.
  7. Painting: Include surface preparation, priming and finish coating as required for electrical cabinets, exposed conduit, pull and junction boxes, etc. where indicated as field painted in this Division.
  8. Lighting fixture supports: Provide slack fixture support wire for lighting fixtures installed in acoustical tile or lay-in suspended ceilings.
- D. Work furnished and installed under another Division requiring connections under this Division includes but is not limited to:
1. Electric motors.
  2. Flow switches and valve monitors for sprinkler system.
  3. Pre-wired electrified partition furniture.
  4. Irrigation controller(s). (Line voltage only)
  5. Electric door locks.
  6. Electric heat trace tape.
  7. Door hold-open/release devices.
  8. Variable frequency drive units.

## 1.2 QUALITY ASSURANCE

- A. Reference to Codes, Standards, Specifications and recommendations of technical societies, trade organizations and governmental agencies shall mean that latest edition of such publications adopted and published prior to submittal of the bid. Such codes or standards shall be considered a part of this Specification as though fully repeated herein.
- B. When codes, standards, regulations, etc. allow Work of lesser quality or extent than is specified under this Division, nothing in said codes shall be construed or inferred authority for reducing the quality, requirements or extent of the Contract Documents. The Contract Documents address the minimum requirements for construction.
- C. Work shall be performed in accordance with all applicable requirements of the latest edition of all governing codes, rules and regulations including but not limited to the following minimum standards, whether statutory or not:
  1. California Electric Code (CEC).
  2. California Building Code (CBC).
  3. California Fire Code (CFC).
  4. California Mechanical Code (CMC).
- D. Standards: Equipment and materials specified under this Division shall conform to the following standards where applicable:
 

ACI	American Concrete Institute
ANSI	American National Standards Institute
ASTM	American Society for Testing Materials
CBM	Certified Ballast Manufacturers
ETL	Electrical Testing Laboratories

FS	Federal Specification
IEEE	Institute of Electrical and Electronics Engineers, Inc.
IPCEA	Insulated Power Cable Engineer Association
NEMA	National Electrical Manufacturer's Association
UL	Underwriters' Laboratories

### 1.3 DEFINITION OF TERMS

A. The following list of terms as used in the Division 26 documents shall be defined as follows:

1. "Provide": Shall mean furnish, install and connect unless otherwise indicated.
2. "Furnish": Shall mean purchase and deliver to Project site.
3. "Install": Shall mean to physically install the items in-place.
4. "Connect": Shall mean make final electrical connections for a complete operating piece of equipment.
5. "As directed": Shall be as directed by the Owner or their authorized Representative.
6. "Utility Companies": Shall mean the company providing electrical, telephone or cable television services to the Project.

### 1.4 SUBMITTALS

- A. Format: Furnish submittal data in electronic format for each Specification Section with a table of contents listing materials by Section and paragraph number.
- B. Submittals shall consist of detailed Shop Drawings, Specifications, block wiring diagrams, "catalog cuts" and data sheets containing physical and dimensional information, performance data, electrical characteristics, materials used in fabrication and material finish. Clearly indicate by arrows or brackets precisely what is being submitted on and those optional accessories which are included and those which are excluded. Furnish quantities of each submittal as noted in Division 01.
- C. Each submittal shall be labeled with the Specification Section Number and shall be accompanied by a cover letter or shall bear a stamp stating that the submittal has been thoroughly reviewed by the Contractor and is in full compliance with the requirements of the Contract Documents. Cover letters shall list in full the items and data submitted. Failure to comply with this requirement shall constitute grounds for rejection of data.
- D. The Contractor shall submit detailed Drawings of all electrical equipment rooms and closets if the proposed installation layout differs from the construction documents. Physical size of electrical equipment indicated on the Drawings shall match those of the electrical equipment that is being submitted for review, i.e.: switchboards, panelboards, transformers, control panels, etc. Minimum scale: 1/4" = 1'- 0". Revised electrical equipment layouts must be approved prior to release of order for equipment and prior to installation.
- E. The Manufacturer shall recommend the method of anchoring the equipment to the mounting surface and shall provide the Contractor with the assembly dimensions, weights and approximate centers of gravity.
- F. All resubmittals shall include a cover letter that lists the action taken and revisions made to each Drawing and equipment data sheet in response to Submittal Review Comments. Resubmittal packages will not be reviewed unless accompanied by this cover letter. Failure to include this cover letter will constitute rejection of the resubmittal package.

G. Shop Drawings for the following systems must be prepared via a computer aided drafting (CAD) system for submission by the Contractor. The Engineer in either Autocad Release/Revit file format can provide files of the electrical Contract Documents to the Contractor.

1. Fire alarm system, Section 26 61 13.

H. Substitutions:

1. All requests for substitutions shall conform to the general requirements and procedure outlined in Division 01.
2. All substitutions need to comply with the instructions to bidders and follow the conditions of contract Article 3 contractor's responsibilities section 3.4.1.

## 1.5 COORDINATION

A. Discrepancies:

1. In the event of discrepancies within the Contract Documents, the Engineer shall be so notified, within sufficient time, as delineated in Division 01, prior to the Bid Opening to allow the issuance of an Addendum.

B. Project conditions:

1. Examination of Project site: The Contractor shall visit the Project site and thoroughly review the locale, working conditions, conflicting utilities and the conditions in which the Electrical Work will take place. Verify all existing conditions in the field. No allowances will be made subsequently for any costs that may be incurred because of any error or omission due to failure to examine the Project site and to notify the Engineer of any discrepancies between Contract Documents and actual Project site conditions.
2. Protection: Keep conduits, junction boxes, outlet boxes and other openings closed to prevent entry of foreign matter. Cover fixtures, equipment, devices and apparatus and protect them against dirt, paint, water, chemical or mechanical damage, before and during construction period. Prior to final acceptance, restore to original condition any fixture, apparatus or equipment damaged including restoration of damaged factory applied painted finishes. Protect bright finished surfaces and similar items until in service. No rust or damage will be permitted.
3. Supervision: Contractor shall personally or through an authorized and competent representative constantly supervise the Work from beginning to completion and, within reason, keep the same foreman and workmen on the Project throughout the Project duration.

C. Preparation:

1. Drawings:

Layout: General layout indicated on the Drawings shall be followed except where other Work may conflict with the Drawings.

Accuracy: Drawings for the Work under this Section are essentially diagrammatic within the constraints of the symbology applied.

## 1.6 RECORD DOCUMENTS

A. Provide Project Record Drawings as described herein:

1. Drawings shall fully represent installed conditions including actual locations of outlets, true panelboard connections following phase balancing routines, correct conduit and wire sizing as well as routing, revised fixture schedule listing Manufacturers and products actually installed and revised panel schedules. Contractor shall record all changes in the Work during the course of construction on blue or black line prints. These prints shall be made subject of monthly review by the Owner's Representative to ascertain that they are current. If not current monthly payments may be withheld.
2. Record Drawings shall be the transfer of information on these prints to the construction documents via computer aided drafting (CAD) process. A set of CAD files of the electrical documents will be provided to the Contractor in either Autocad Release 14 or DXF file format.
3. Record drawing submissions shall be provided to the Engineer to review upon the completion of the following phases of Work:
  - a. \Building electrical rough-in.
  - b. Final electrical installation.
4. Include in the record drawing submission the following shop drawing submission with all updated installation information:
  - a. Fire alarm system.
  - b. Security system.
5. A single set of half size prints of the Record Drawings shall be submitted for review. Upon receipt of the Engineer's review comments, corrections shall be made and the Contractor shall provide the following:
  - a. Two sets of full size prints.
  - b. Four sets of half size prints.
  - c. One set of full size reproducibles.

B. Panel schedules:

1. Typewritten panel schedules shall be provided for panelboards indicating the loads served and the correct branch circuit number. Schedules shall be prepared on forms provided by the Manufacturer and inserted in the pocket of the inner door of each panelboard. See Section 26 24 16: Panelboards for requirements.
2. A single set of the record panel schedules shall be submitted for review. Upon receipt of the Engineer's review comments, corrections shall be made and the Contractor shall provide the following:
  - a. Fold and insert one copy of the appropriate schedule in the pocket of the inner door of each panelboard.

1.7 OPERATION AND MAINTENANCE MANUALS

- A. Prior to Project closeout furnish to the Owner, two (2) hard back 3-ring binders containing all bulletins, operation and maintenance instructions, part lists, service telephone numbers and other pertinent information as noted in each Section all equipment furnished under Division 26. Binders shall be indexed into Division Sections and labeled for easy reference. Bulletins containing more information than the equipment concerned shall be properly stripped and assembled. Provide one PDF electronic version.



## PART 2 - PRODUCTS (NOT APPLICABLE)

## PART 3 - EXECUTION

### 3.1 ROUGH-IN

- A. Contractor shall verify lines, levels and dimensions indicated on the Drawings and shall be responsible for the accuracy of the setting out of Work and for its strict conformance with existing conditions at the Project site.
- B. Verify final locations for rough-ins with field measurements and with the requirements for the actual equipment to be connected.
- C. Refer to equipment specification in Divisions 22 through 33 for rough-in requirements.

### 3.2 ELECTRICAL INSTALLATION

- A. Preparation, sequencing, handling and installation shall be in accordance with Manufacturer's written instructions and technical data particular to the product specified and/or accepted equal except as otherwise specified. Comply with the following requirements:
  - 1. Shop Drawings prepared by Manufacturer.
  - 2. Verify all dimensions by field measurements.
  - 3. Arrange for chases, slots and openings in other building components during progress of construction, to allow for electrical installations.
  - 4. Coordinate the installation of required supporting devices and sleeves to be set in poured-in-place concrete and other structural components, as they are constructed.
  - 5. Sequence, coordinate and integrate installations of electrical materials and equipment for efficient flow of the Work. Give particular attention to large equipment requiring positioning prior to closing in the building.
  - 6. Where mounting height is not detailed or dimensioned, contact the Architect for direction prior to proceeding with rough-in.
  - 7. Install systems, materials and equipment to conform with approved submittal data, including coordination Drawings, to greatest extent possible. Conform to arrangements indicated by the Contract Documents, recognizing that portions of the Work are indicated only in diagrammatic form. Where coordination requirements conflict with individual system requirements, refer conflict to the Architect.
  - 8. Install systems, materials and equipment level and plumb, parallel and perpendicular to other building systems and components, where installed exposed in finished spaces.
  - 9. Install electrical equipment to facilitate servicing, maintenance and repair or replacement of equipment components. As much as practical, connect equipment for ease of disconnecting, with minimum of interference with other installations.
  - 10. Coordinate electrical systems, equipment and materials installations with other building components.
  - 11. Provide access panel or doors where devices or equipment are concealed behind finished surfaces. Furnish and install access doors per the requirements of Division 08.
  - 12. Install systems, materials and equipment giving right-of-way priority to other systems that are required to maintain a specified slope.
  - 13. Conform to the National Electrical Contractor's Association "Standard of Installation" for general installation practice.

### 3.3 CUTTING, PATCHING, PAINTING AND SEALING

- A. Structural members shall in no case be drilled, bored or notched in such a manner that will impair their structural value. Cutting of holes, if required, shall be done with core drill and only with the approval of the Architect and Structural Engineer.
- B. Protection of Installed Work: During cutting and patching operations, protect adjacent installations.
- C. Protect the structure, furnishings, finishes and adjacent materials not indicated or scheduled to be removed.
- D. Patch existing surfaces and building components using experienced installers and new materials matching existing materials and the original installation. For installers' qualifications refer to the materials and methods required for the surface and building components being patched.
- E. Application of joint sealers:
  - 1. General: Comply with joint sealer Manufacturers' printed application instructions applicable to products and applications indicated, except where more stringent requirements apply.
  - 2. Installation of fire-stopping sealant: Install sealant, including forming, packing and other accessory materials, to fill openings around electrical services penetrating floors and walls, to provide fire-stops and fire-resistance ratings indicated for floor or wall assembly in which penetration occurs. Comply with installation requirements established by testing and inspecting agency.

### 3.4 FIELD QUALITY CONTROL

- A. General testing requirements:
  - 1. The purpose of testing is to ensure that all tested electrical equipment, both Contractor and Owner supplied, is operational and within industry and Manufacturer's tolerances and is installed in accordance with design Specifications.
  - 2. Tests and inspections shall determine suitability for energization.
  - 3. Perform tests in presence of the Owner's Representative and furnish test equipment, facilities and technical personnel required to perform tests.
  - 4. Tests shall be conducted during the construction period and at completion to determine conformity with applicable codes and with these Specifications.
- B. Tests: In addition to specific system test described elsewhere, tests shall include:
  - 1. Equipment operations: Test motors for correct operation and rotation.
  - 2. Lighting control circuits: Test lighting circuits for correct operation through their control devices.
  - 3. Alarm and interlock systems: Produce malfunction symptoms in operating systems to test alarm and interlock systems. In addition, all specific tests described in the fire alarm system shall be performed.
  - 4. Circuit numbering verification: Select on a random basis various circuit breakers in the panelboards and cycle them on and off to verify compliance of the typed panel directories with actual field wiring.
  - 5. Voltage check:

- a. At completion of job, check voltage at several points of utilization on the system that has been installed under this Contract. During test, energize all installed loads.
- C. Contractor shall provide test power required when testing equipment before service energization and coordinate availability of test power with General Contractor after service energization. The Contractor shall provide any specialized test power as needed or specified herein.
- D. Testing safety and precautions:
  - 1. Safety practices shall include the following requirements:
  - 2. Applicable State and Local safety operating procedures.
    - a. OSHA.
    - b. NSC.
    - c. NFPA 70E.
  - 3. All tests shall be performed with apparatus de-energized and grounded except where otherwise specifically required ungrounded by test procedure.

### 3.5 cleaning

- A. Prior to energizing of electrical equipment, the Contractor shall thoroughly clean the interior of enclosures from construction debris, scrap wire, etc. using Manufacturer's approved methods and materials.
- B. Upon completion of Project, prior to final acceptance, the Contractor shall thoroughly clean both the interior and exterior of all electrical equipment per Manufacturers approved methods and materials. Remove paint splatters and other spots, dirt and debris.
- C. Touch-up paint any marks, blemishes or other finish damage suffered during installation.

### 3.6 PROJECT CLOSEOUT

- A. Training: At the time of completion, a period of not less than 2 hours shall be allotted by the Contractor for instruction of building operating and maintenance personnel in the use of all systems. This training is in addition to any instruction time called out in the Specifications for specific systems. All personnel shall be instructed at one time, the Contractor making all necessary arrangements with Manufacturer's Representative. The equipment Manufacturer shall be requested to provide product literature and application guides for the users' reference. Costs, if any, for the above services shall be paid by the Contractor.
- B. Special tools: Provide one of each tool required for proper operation and maintenance of the equipment provided under this Section. All tools shall be delivered to the Owner at the Project completion.
- C. Keying: Provide two keys for each lock furnished under this Section and turn over to Owner.

**END OF SECTION 26 00 10**

## **SECTION 26 00 90 - ELECTRICAL DEMOLITION**

### **PART 1 - GENERAL**

#### **1.1 SUMMARY**

- A. Work included: Labor and equipment necessary to complete the demolition required for the item specified under this Division, including but not limited to:

- 1. Selective Electrical demolition

#### **1.2 SYSTEM DESCRIPTION**

- A. Disconnection, removal and relocation of all wiring, light fixtures, outlets, conduit and all other types of electrical equipment as described on Drawings.
- B. Purpose is to remove, relocate and extend existing installations to accommodate new construction.

### **PART 2 - PRODUCTS**

#### **2.1 MATERIALS AND EQUIPMENT**

- A. Materials and equipment necessary for patching and extending Work, as specified in other Sections.

### **PART 3 - EXECUTION**

#### **3.1 EXAMINATION**

- A. Contractor shall thoroughly review conditions in the area of demolition prior to commencing Work to ensure complete understanding of existing installation in relationship to demolition Work.

#### **3.2 GENERAL REQUIREMENTS**

- A. Remove all wiring, light fixtures, outlets, conduit and all other types of electrical equipment indicated to be removed. Devices that are to be removed may require reworking conduit and wiring in order to maintain service to other devices. If removed devices are on walls or ceilings that are to remain, blank coverplates are to be installed on outlet boxes.
- B. Where remodeling interferes with circuits in areas that are otherwise undisturbed, circuits shall be reworked as required.
- C. Existing devices and circuiting that are indicated are indicated only for informational purposes. Contractor shall visit the Project site and shall verify conditions as they exist and shall remove, relocate and/or rework any electrical equipment or circuits affected (whether indicated or not) due to removal of existing walls, ceilings, etc. Coordinate all Work with that of other trades.
- D. All items which are removed and not wanted by the Owner and which are not reused shall become the property of the Contractor and shall be legally removed from the Project site.
- E. Cutting and patching necessary for the removal of Electrical Work shall be included.

- F. Remove and replace lighting fixtures, rework, relocate or replace conduit and wiring and do other Work required by the installation of new ductwork, piping, etc., above the ceiling. Coordinate with other trades and verify the extent of the Work.

### 3.3 LIGHT FIXTURES

- A. Disconnect and remove abandoned light fixtures. Remove conduits, wiring, boxes, brackets, stems, hangers and other accessories.

### 3.4 OUTLETS

- A. Disconnect remove devices as coordinated with the electrical construction document drawings. Remove abandoned outlets if conduit servicing them is abandoned and removed. Provide blank cover for abandoned outlets that are not removed.

### 3.5 CONDUIT

- A. Remove abandoned conduit, including abandoned conduit above accessible ceiling finishes. Cut conduit flush with walls and floors and patch surfaces.

### 3.6 WIRING

- A. Removed abandoned wiring to source of supply.

### 3.7 EXISTING SYSTEMS

- A. Electrical distribution system: Disable system only to make switchovers and connections. Obtain permission from Owner's designated representative at least 24 hours before partially or completely disabling system. Minimize outage duration. Make temporary connections to maintain service in areas adjacent to Work area.
- B. Fire alarm system: Existing FACP and devices shall be demoed. Coordinate installation of new system in field with demolition of existing. Notify Owner and Fire Supervisory Service at least 24 hours before partially or completely disabling the system.
- C. Telephone system: Maintain the existing fiber system throughout construction. Provide new work as outlined in Division 27. Notify Owner and Telephone Utility at least 24 work week hours before partially or completely disabling the system.

### 3.8 CLEANING AND REPAIR

- A. Clean and repair existing materials and equipment that shall remain.
- B. Panelboards: Clean exposed surfaces and check tightness of electrical connections. Replace damaged circuit breakers and provide closure plates for vacant positions. Provide typed circuit directory showing revised circuiting arrangement.
- C. Luminaries: Remove lenses and lamps and clean all exposed surfaces. Also clean the lenses or replace if discolored. Provide all new lamping when re-assembling.

**END OF SECTION 26 00 90**

## SECTION 26 05 19 - BUILDING WIRE AND CABLE

### PART 1 - GENERAL

#### 1.1 SUMMARY

- A. Work included: Labor, materials and equipment necessary to complete the installation required for the item specified under this Division, including but not limited to:
1. Building wire.
  2. Cable.
  3. Wiring connections and terminations.
- B. Related Work: Consult all other Sections, determine the extent and character of related Work and properly coordinate Work specified herein with that specified elsewhere to produce a complete installation.

#### 1.2 REFERENCES

- A. Comply with the latest edition of the following applicable Specifications and standards except as otherwise indicated or specified:
1. Federal Specifications (FS):
    - FS J-C-30A; Cable and Wire, Electrical (Power, Fixed Installation).
    - FS W-S-610C; Splice Conductor.
    - FS HH-I-595C; Insulation Tape, Electrical, Pressure-Sensitive Adhesive, Plastic.
  2. Underwriters Laboratories, Inc. (UL):
    - UL 4; Armored Cable.
    - UL 44; Thermoset-Insulated Wires and Cables.
    - UL 62; Flexible Cord and Fixture Wire.
    - UL 83; Thermoplastic-Insulated Wires and Cables.
    - UL 183; Manufactured Wiring Systems.
    - UL 310; Electrical Quick-Connect Terminals.
    - UL 486A & B; Wire Connectors.
    - UL 486C; Splicing Wire Connectors.
    - UL 486D; Insulated Wire Connector Systems for Underground Use or in Damp or Wet Locations.
    - UL 493; Thermoplastic-Insulated Underground Feeder and Branch Circuit Cables.
    - UL 510; Polyvinyl Chloride, Polyethylene and Rubber Insulating Tape.
    - UL 854; Service-Entrance Cables.
    - UL 1569; Metal-Clad Cables.
    - UL 1581; Reference Standard for Electrical Wires, Cables and Flexible Cords.
  3. National Electrical Manufacturer Association (NEMA):
    - NEMA WC-5; Thermoplastic Insulated Wire and Cable for the Transmission and Distribution of Electrical Energy.
    - NEMA WC-7; Cross-Linked Thermosetting Polyethylene Insulated Wire and Cable for the Transmission and Distribution of Electrical Energy.
  4. Institute of Electrical and Electronic Engineers (IEEE):
    - IEEE 82; Test Procedure for Impulse Voltage Tests on Insulated Conductors.

### 1.3 SUBMITTALS

- A. Submit in accordance with the requirements of Section 26 00 10: Basic Electrical Requirements, the following items:
  - 1. Data/catalog cuts for each product and component specified herein, listing all physical and electrical characteristics and ratings indicating compliance with all listed standards.
  - 2. Clearly mark on each data sheet the specific item(s) being submitted and the proposed application.
  - 3. Submit Manufacturer's installation instructions.
  - 4. Final test results.

### 1.4 QUALITY ASSURANCE

- A. All materials, equipment and parts comprising the units specified herein shall be new, unused and currently under production.
- B. Only products and applications listed in this Section may be used on the Project unless otherwise submitted.

## PART 2 - PRODUCTS

### 2.1 MANUFACTURERS

- A. Products furnished by the following Manufacturers shall be acceptable if in compliance with all features specified herein and indicated on the Drawings.
  - 1. Building wire:
    - a. Cerrowire
    - b. General Cable
    - c. Southwire Company
    - d. Stabiloy (aluminum only)
    - e. United Wire and Cable
  - 2. Metal-Clad:
    - a. AFC Cable Systems
    - b. AFC Cable Systems – MC Luminary Cable (0-10V)
    - c. Southwire Company
  - 3. Flexible Cords and Cables:
    - a. Carol Cable Company
    - b. Cerrowire
    - c. PWC Corp
  - 4. Wiring connectors and terminations:
    - a. 3M Company.
    - b. Ideal.
    - c. Blackburn-Holub.
    - d. Burndy.
    - e. Thomas & Betts Corp.
    - f. Beau Barrier.

## 2.2 BUILDING WIRE

### A. Conductor material:

1. Provide annealed copper for all wire, conductor and cable, unless otherwise indicated.
2. Copper wire AWG #8 and larger shall be stranded, unless otherwise indicated.
3. Copper wire AWG #10 and smaller may be solid or stranded as best suited for the installation.

### B. Insulation material:

1. All insulated wire, conductor and cable shall be 600 volt rated unless otherwise noted on the Drawings.
2. Thermoplastic-insulated building wire: NEMA WC 5.
3. Rubber-insulated building wire: NEMA WC 3.
4. Copper feeders and branch circuits larger than #6 AWG: Type THW, XHHW or dual rated THHN/THWN.
5. Copper feeders and branch circuits #6 AWG and smaller: Type TW, THW, XHHW or dual rated THHN/THWN.
6. Control Circuits: Type THW or dual rated THHN/THWN.
7. Identify system conductors as to voltage and phase connections by means of color-impregnated insulation.

## 2.3 METAL-CLAD CABLE (MC)

- A. MC cable shall be an armored assembly of two or more dual rated THHN/THWN annealed copper conductors with a full sized green insulated ground wire.
- B. MC cable sheath shall be fabricated in continuous lengths from galvanized steel, spirally wound and formed to provide an interlocking design.
- C. Conductors shall be color-coded for the correct phase and voltage as specified herein.
- D. Fittings: Connectors shall be of the single screw clamp variety with steel or cast malleable iron bodies and threaded male hubs with insulated throats. Fittings shall be UL listed for use with MC cable type specified.
- E. MC cable used for 0-10V signal wiring shall have the 0-10V wires twisted at a different twist ratio than that of the current carrying conductors.

## 2.4 WIRING CONNECTIONS AND TERMINATIONS

- A. Bolted pressure connectors: Provide wide range-taking connectors with cast bronze compression bolts, designed for parallel taps, tees, crosses or end-to-end connections.
- B. Electrical spring wire connectors:
  1. Provide multi-part construction incorporating a non-restricted, zinc coated square cross-section steel spring enclosed in a steel sheet with an outer jacket of plastic and insulating skirt.
  2. Self-striping pigtail and tap U-contact connectors shall not be used.
- C. Push-in wire connectors:
  1. Multi-port push-in wire connectors for a maximum of 8-wires, as required for specific application. Connectors are manufactured to accommodate a wide range of sizes with



- either solid or stranded conductors, up to a maximum wire size of #10 AWG. Low insertion force required for ease of installation.
2. Housing shall be 105 degrees C and transparent for visual connection verification.
  3. 600 volt maximum rating with copper contacts.
  4. UL Listed to 486C and UL 467 Listed for grounding and bonding applications.
- D. Compression type terminating lugs:
1. Provide tin-plated copper high-compression type lugs for installation with hand or hydraulically operated circumference-crimping tools and dies as stipulated by the lug Manufacturer or as indicated on Drawings. Notch or single point type crimping is NOT acceptable.
  2. Two hole, long barrel lugs shall be provided for size (4/0) and larger wire where terminated to bus bars. Use minimum of three crimps per lug, on sizes where possible.
- E. Splicing and insulating tape: Provide black, ultraviolet proof, self-extinguishing, 7 mil thick vinyl general purpose electrical tape with a dielectric strength of 10,000 volts suitable for temperatures from minus 18 degrees C to 105 degrees C. Federal Spec. HH-I-595, Scotch 33+ or equal minimum.
- F. Insulating putty:
1. Provide pads or rolls of non-corrosive, self-fusing, one-eighth inch thick rubber putty with PVC backing sheet. Scotch vinyl mastic pads and roll or equal.
  2. Use putty suitable for temperatures from minus 17.8 degrees C to 37.8 degrees C with a dielectric strength of 570-volts/mil minimum.
- G. Insulating resin:
1. Provide two-part liquid epoxy resin with resin and catalyst in pre-measured, sealed mixing pouch. Scotchcast 4 or equal for wet or underground vaults, boxes, etc. splices or terminations.
  2. Use resin with a set up time of approximately 30 minutes at 21.1 degrees C and with thermal and dielectric properties equal to the insulating properties of the cables immersed in the resin.
- H. Terminal strips:
1. Provide box type terminal strips in the required quantity plus 25% spare. Install in continuous rows in terminal cabinets.
  2. Use the box type terminal strips with barrier open backs and with ampere ratings as required.
  3. Identify all terminals with numbering sequence being used for a particular system.
- I. Crimp type connectors:
1. Provide insulated fork or ring crimp terminals with tinned electrolytic copper-brazed barrel with funnel wire entry and insulation support
  2. Fasten crimp type connectors or terminals using a crimping tool recommended by the connector Manufacturer.
  3. Provide insulated overlap splices with tinned seamless electrolytic copper barrel with funnel wire entry and insulation support.
  4. Provide insulated butt splices with tinned seamless electrolytic copper barrel with center stop, funnel wire entry and insulation support.
- J. Cable ties: Provide harnessing and point-to-point wire bundling with nylon cable ties. All cable ties shall be installed using tool supplied by Manufacturer of ties.

- K. Wire lubricating compound:
1. UL listed for the wire insulation and conduit type and shall not harden or become adhesive.
  2. Shall not be used on wire for isolated type electrical power systems.
- L. Bolt termination hardware:
1. Bolts shall be plated, medium carbon steel heat-treated, quenched and tempered equal to ASTM A-325 or SAE grade 5; or silicon bronze alloy ASTM B-9954 Type B.
  2. Nuts shall be heavy semi-finished hexagon, conforming to ANSI B18.2.2, threads to be unified coarse series (UNC), class 2B steel or silicon bronze alloy.
  3. Flat washers shall be steel or silicon bronze, Type A plain standard wide series, conforming to ANSI B27.2. SAE or narrow series shall not be used.
  4. Belleville conical spring washers shall be hardened steel, cadmium plated or silicon bronze.
  5. Each bolt connecting lug(s) to a terminal or bus shall not carry current exceeding the following values:
    - a. 1/4" bolt - 125 amps
    - b. 5/16" bolt - 175 amps
    - c. 3/8" bolt - 225 amps
    - d. 1/2" bolt - 300 amps
    - e. 5/8" bolt - 375 amps
    - f. 3/4" bolt - 450 amps

### PART 3 - EXECUTION

#### 3.1 EXAMINATION

- A. Contractor shall thoroughly examine Project site conditions for acceptance of wire and cable installation to verify conformance with Manufacturer and Specification tolerances. Do not commence with installation until all conditions are made satisfactory.

#### 3.2 APPLICATION

- A. All wire, conductor and cable with their respective connectors, fittings and supports shall be UL listed for the installed application and ambient condition.
- B. Feeders and branch circuits in wet locations shall be rated 75 degree C.
- C. Feeders and branch circuits in dry locations shall be rated 90 degree C.
- D. Minimum conductor size:
1. Provide minimum AWG #12 for all power and lighting branch circuits.
  2. Provide minimum AWG #14 for all line voltage signal and control wiring unless otherwise indicated.
- E. Color coding:
1. For 120/208 volt, 3 phase, 4 wire systems:
    - a. Phase A - Black
    - b. Phase B - Red
    - c. Phase C - Blue

- d. Neutral - White
  - e. Ground - Green
- 2. Switch leg individually installed shall be the same color as the branch circuit to which they are connected, unless otherwise noted.
  - 3. Travelers for 3-way and 4-way switches shall be a distinct color and pulled with the circuit switch leg or neutral.

### 3.3 WIRING METHODS

- A. Install wires and cables in accordance with Manufacturer's written instructions, as indicated on Drawings and as specified herein.
- B. Install all single conductors in raceway system, unless otherwise noted.
- C. Parallel circuit conductors and terminations shall be equal in length and identical in all ways.
- D. Provide adequate length of conductors within electrical enclosures and train the conductors to terminal points with no excess. Bundle multiple conductors, with conductors larger than #10 AWG cabled in individual circuits. Make terminations so there is no bare conductor at the terminal.
- E. 20 amp power and lighting branch circuit containing no more than four (4) current carrying conductors (phases and neutrals). Use #10 AWG conductor for 120/208 volt circuits located outside a 75 foot radius of panel source unless otherwise noted.
- F. 20 amp power and lighting branch circuits containing no more than eight (8) current carrying conductors (phases and neutrals). Use #10 AWG conductors for 120/208 volt circuits located outside a 65 foot radius of panel.
- G. Provide #10 AWG pig tails on all 20A and 30A wiring devices served by #8 AWG conductors and larger.
- H. Splice cables and wires only in outlet boxes, junction boxes, pull boxes, manholes or handholes. Group and bundle with tie wrap each neutral with its associated phase conductor where more than one neutral is present in a conduit.
- I. Install cable supports for all vertical feeders in accordance with the NEC Article 300. Provide split wedge type fittings, which firmly clamp each individual cable and tighten due to cable weight.
- J. Neatly form, train and tie the cables in individual circuits. For panelboards, cabinets, wireways, switches and equipment assemblies.
- K. Seal cable or wire, entering a building from underground, between the wire or cable and conduit, where it exits the conduit, with a non-hardening approved compound, i.e. duct seal or equal.
- L. Provide UL-listed factory-fabricated, solderless metal connectors of size, ampacity rating, material, type and class for applications and for services indicated. Use connectors with temperature ratings equal to or greater than the wires that are being terminated.
- M. Stranded wire shall be terminated using fitting, lugs or devices listed for the application. However, in no case shall stranded wire be terminated solely by wrapping it around a screw or bolt.

- N. Flexible cords and cables supplied, as part of a pre-manufacturer fixture or unit assembly shall be installed according to Manufacturers published installation instructions.

### 3.4 WIRING INSTALLATION IN RACEWAYS

- A. Install wire in raceway after interior of building has been physically protected from the weather and all mechanical Work likely to injure conductors has been completed. Pull all conductors into a raceway at the same time. Exercise care in pulling conductors so that insulation is not damaged. Use UL listed, non-petroleum base and insulating type pulling compound as needed.
- B. Completely mandrel all underground or concrete encased conduits prior to installing conductors.
- C. Completely and thoroughly swab raceway system before installing conductors.
- D. Do not use block and tackle, power driven winch or other mechanical means for pulling conductors of size smaller than AWG #1.
- E. Wire pulling:
  - 1. Provide installation equipment that will prevent the cutting or abrasion of insulation during pulling of cables.
  - 2. Use rope made of nonmetallic material for pulling feeders.
  - 3. Attach pulling lines for feeders by means of either woven basket grips or pulling eyes attached directly to the conductors.
  - 4. Pull in together multiple conductors or cables in a single conduit.
- F. Install and test all cables in accordance with Manufacturer's instructions and warranty.

### 3.5 MC CABLE INSTALLATION

- A. The Drawings indicate above suspended ceiling power distribution junction boxes for conversion from hardwire to MC cable wiring system. Install these boxes such that they are accessible from below. MC cable shall be run to each device as described in documents. MC cable runs have not been indicated. Refer to Shop Drawings for installation.
- B. Install MC cable in accordance with Manufacturer's instructions and in strict accordance with NEC Article 334. Follow Manufacturer's explicit instructions when connecting the cable to fittings and boxes. Connectors shall be firmly secured to the cable, but not over-tightened. Connector shall be firmly attached to the metal boxes.
- C. Support cables every 6 feet and within 12 inches of boxes, per NEC Article 334, using separate spring metal clip or metal cable ties (not steel tie wire) for each cable. Cables shall not be bundled together.
- D. Suspended ceiling drop wire may be used to directly support a maximum of two separate MC cables.
- E. Provide separate drop wire above accessible ceiling, to support more than (2) two MC cables.
- F. Do not rest cables on ceiling tiles or allow contact with mechanical piping systems.
- G. Bend the cable per NEC Article 334.

- H. Provide separate sleeves and/or fire barriers where cable penetrated firewalls, unless cable is UL listed for the application.

### 3.6 WIRE SPLICES, JOINTS and TERMINATION

- A. Join and terminate wire, conductors and cables in accordance with UL 486A, C, NEC and Manufacturer's instructions.
- B. Thoroughly clean wires before installing lugs and connectors.
- C. Make splices, taps and terminations to carry full ampacity of conductors without perceptible temperature rise.
- D. Splices and terminations shall be made mechanically and electrically secure.
- E. Where it's determined that unsatisfactory splice or terminations have been installed, remove the devices and install approved devices at no addition cost.
- F. Terminate wires in Terminal Cabinets, relay and contactor panels, etc. using terminal strip connectors.
- G. Insulate spare conductors with electrical tape and leave sufficient length to terminate anywhere in the panel or cabinet.
- H. Install cable ties and maintain harnessing.
- I. Encapsulate splices in exterior outlets, pullboxes and junction boxes using specified insulating resin kits. Make all splices watertight for exterior equipment and equipment in pump rooms.
- J. Make up all splices and taps in accessible junction or outlet boxes with connectors as specified herein. Pigtails and taps shall be the same color as the feed conductor. Form conductor prior to cutting and provide at least six (6) inches of tail and neatly packed in box after splice is made up.
- K. Branch circuits (#10 AWG and smaller):
  - 1. Connectors: Solderless, screw-on, reusable spring pressure cable type, 600 volt, 105-degree C. with integral insulation, approved for copper conductors.
  - 2. The integral insulator shall have a skirt to completely cover the stripped wires.
  - 3. The number, size and combination of conductors as listed on the Manufacturers packaging shall be strictly complied with.
- L. Feeder circuits: (#6 to 750 MCM)
  - 1. Join or tap conductors from #6 AWG to 750 MCM using bolted pressure connectors or insulate mechanical compression (hi-press) taps with pre-molded, snap-on insulating boots or specified conformable insulating pad and over wrapped with two half-lapped layers of vinyl insulating tape starting and ending at the middle of the joint.
  - 2. Terminate conductors from size #6 AWG to 750 MCM copper using bolted pressure or mechanical compression lugs in accordance with Manufacturer recommendation or as specified elsewhere.
  - 3. Field installed compression connectors for cable sizes 250 MCM and larger shall have not less than two clamping elements or compression indents per wire.
  - 4. Insulate splices and joints with materials approved for the particular use, location, voltage and temperature. Insulate with not less than that of the conductor level that is being joined.

M. Termination hardware assemblies:

1. AL/CU lugs connected to aluminum plated or copper buss, shall be secured using a steel bolt, flat washer (two per bolt), Belleville washer and nut.
2. Copper lugs connected to copper bus, shall be secured using silicon bronze alloy bolt, flat washer (two per bolt), Belleville washer and nut.
3. The crown of Belleville washers shall be under the nut.
4. Bolt assemblies shall be torque to Manufacturer recommendation. Where manufacture recommendation are not obtainable, the following values shall be used:
  - a. 1/4" - 20 bolt at 80-inch pounds torque.
  - b. 5/16" - 18 bolt at 180-inch pounds torque.
  - c. 3/8" - 16 bolt at 20-foot pounds torque.
  - d. 1/2" - 13 bolt at 40-foot pounds torque.
  - e. 5/8" - 11 bolt at 55-foot pounds torque.
  - f. 3/4" - 10 bolt at 158-foot pounds torque.

3.7 IDENTIFICATION

- A. Refer to Section 26 05 53: Electrical Identification for additional requirements.
- B. Securely tag all branch circuits. Mark conductors with specified vinyl wrap-around markers. Where more than two conductors run through a single outlet, mark each conductor with the corresponding circuit number.
- C. Color code conductors size #8 and larger using specified phase color markers and identification tags.
- D. Provide all terminal strips with each individual terminal identified using specified vinyl markers.
- E. In pullboxes and handholes, provide tags of the embossed brass type and also show the cable type and voltage rating. Attach the tags to the cables with slip-free plastic cable lacing units.

3.8 FIELD QUALITY CONTROL

- A. Prefunctional testing:
  1. Visual and mechanical inspection:
    - a. Compare cable data with Contract Documents.
    - b. Inspect exposed sections of wires and cables for physical damage and proper connections.
    - c. Verify tightness of accessible bolted connections with calibrated torque wrench in accordance with Manufacturer's published data.
    - d. Inspect compression applied connectors for correct cable match and indentation.
    - e. Verify visible cable bend meet or exceed ICEA and Manufacturer's minimum allowable bending radius.
    - f. If cables are terminated through window type current transformers, make an inspection to verify neutral and ground conductors are correctly placed for operation of protective devices.
    - g. Ensure wire and cable identification has been installed as specified herein.

**END OF SECTION 26 05 19**

**SECTION 26 05 26 - GROUNDING AND BONDING**

**PART 1 - GENERAL**

**1.1 SUMMARY**

- A. Work included: Labor, materials and equipment necessary to complete the installation required for the item specified under this Division, including but not limited to:
  - 1. Power system grounding.
  - 2. Electrical equipment and raceway grounding and bonding.
- B. Related Work: Consult all other Sections, determine the extent and character of related Work and properly coordinate Work specified herein with that specified elsewhere to produce a complete installation.
  - 1. 27 00 10 BASIC COMMUNICATIONS REQUIREMENTS
  - 2. 27 11 00 COMMUNICATION EQUIPMENT ROOMS

**1.2 REFERENCES**

- A. Comply with the latest edition of the following applicable Specifications and standards except as otherwise indicated or specified:
  - 1. Underwriters Laboratories, Inc. (UL):
  - 2. UL 467; Grounding and Bonding Equipment.
  - 3. Institute of Electrical and Electronics Engineers, Inc. (IEEE):
    - IEEE No. 142; Recommended Practice for Grounding of industrial and Commercial Power Systems.
    - IEEE No. 81 Guide for Measuring Earth Resistivity, Ground Impedance, and Earth Surface Potentials of a Ground System.

**1.3 SYSTEM DESCRIPTION**

- A. Ground the electrical service system neutral at service entrance equipment as described herein and indicated on Drawings.
- B. Ground each separately derived system neutral as described herein and indicated on Drawings.
- C. Provide a safety ground grid and/or mat beneath all electrical switchgear operating at 1000 volts and above, and at emergency generator. Grid/mat shall be poured in the concrete floor slab and constructed as specified herein.
- D. Except as otherwise indicated, the complete electrical installation including the neutral conductor, metallic conduits and raceways, cable trays, boxes, cabinets and equipment shall be completely and effectively grounded in accordance with all code requirements, whether or not such connections are specifically indicated or specified.
- E. Resistance:
  - 1. Resistance from the main switchboard ground bus through the ground electrode to earth shall not exceed 5 OHMS unless otherwise noted.
  - 2. Resistance from the farthest panelboard, switchboard, etc. ground bus through the ground electrode to earth shall not exceed 20 OHMS

#### 1.4 SUBMITTALS

- A. Submit in accordance with the requirements of Section 26 00 10: Basic Electrical Requirements, the following items:
  - 1. Data/catalog cuts for each product and component specified herein, listing all physical and electrical characteristics and ratings indicating compliance with all listed standards.
  - 2. Clearly mark on each data sheet the specific item(s) being submitted and the proposed application.
  - 3. Submit Manufacturer's installation instructions.

#### 1.5 QUALITY ASSURANCE

- A. All materials, equipment and parts comprising the units specified herein shall be new, unused and currently under production.
- B. Only products and applications listed in this Section may be used on the Project unless otherwise submitted.

### PART 2 - PRODUCTS

#### 2.1 MANUFACTURERS

- A. Products furnished by the following Manufacturers shall be acceptable if in compliance with all features specified herein and indicated on the Drawings.
  - 1. Ground Rods:
    - a. Weaver.
    - b. Erico "Cadweld" Products, Inc.
  - 2. Ground Bushings, Connectors, Jumpers and Bus:
    - a. O-Z/Gedney.
    - b. Thomas & Betts Corp.

#### 2.2 GROUND CONDUCTORS

- A. Refer to Specification Section 26 05 19: Building Wire and Cable for conductor specifications.
- B. General purpose insulated:
  - 1. UL approved and code sized copper conductor, with dual rated THHN/THWN insulation, color identified green.
  - 2. Where continuous color-coded conductors are not commercially available, provide a minimum 4" long color band with green, non-aging, plastic tape in accordance with NEC/CEC.
- C. Bare conductors in direct contact with earth or encased in concrete: #2/0 AWG copper minimum, U.O.N.
- D. Bonding pigtails: Insulated copper conductor, identified green, sized per code and provide with termination screw or lug. Provide solid conductors for #10 AWG or smaller and stranded conductors for #8 AWG or larger.



2.3 DRIVEN (GROUND) RODS

- A. Copper clad steel, minimum 3/4-inch diameter by 8 feet long, unless otherwise noted.

2.4 INSULATED GROUNDING BUSHINGS

- A. Plated malleable iron or steel body with 150 degree Centigrade molded plastic insulating throat and lay-in grounding lug.

2.5 CONNECTIONS TO PIPE

- A. For cable to pipe: UL and NEC/CEC approved bolted connection.

B. CONNECTIONS TO STRUCTURAL STEEL, GROUND RODS or SPLICES

- C. Where required by the Drawings, grounding conductors shall be spliced together, connected to ground rods or connected to structural steel using exothermic welds or high pressure compression type connectors.

1. Exothermic welds shall be used for cable-to-cable and cable-to-ground rod and for cable to structural steel surfaces. Exothermic weld kits shall be as manufactured by Cadweld or equal. Each particular type of weld shall use a kit unique to that type of weld.
2. High-pressure compression type connectors shall be used for cable-to-cable and cable-to-ground rod connections.

2.6 EXTRA FLEXIBLE, FLAT BONDING JUMPERS

- A. Where required by Code, indicated on the Drawing, and specified herein.

2.7 BUILDING GROUND BUS requirements

- A. Main building power system ground bus:

1. Provide one 24" wide x 4" high x 1/4" thick copper bus bar as a minimum. Mount on wall in main electrical room utilizing insulating stand-offs at 18" above finished floor.
2. Furnish complete with cast copper alloy body lugs for connecting grounding system conductors. Attach lugs to bus with appropriate size cadmium bronze bolt, flat washer and Belleville washer. Torque all lug connections.
3. All holes shall be drilled and tapped for single-hole lugs. Provide 6 spare lugs and lug spaces.

- B. Building power system reference ground bus:

1. The reference ground bus is furnished as part of the main electrical switchboard for the building, along with neutral disconnect and bus, and is in addition to the main building power system ground bus outlined above. The building grounding electrode shall make a direct connection to the building referenced ground bus in the main switchboard.
2. Provide a #2/0 AWG copper ground conductor connection between the building reference ground bus in switchboard and the main building ground bus wall mounted in main electrical room.

### PART 3 - EXECUTION

#### 3.1 EXAMINATION

- A. Contractor shall thoroughly examine Project site conditions for acceptance of grounding system installation to verify conformance with Manufacturer and Specification tolerances. Do not commence with installation until all conditions are made satisfactory.

#### 3.2 INSTALLATION

- A. Grounding electrodes:
  - 1. Supplementary grounding electrode (ground ring, eufer and driven rods): Provide at least one supplemental grounding electrode and connect to the buildings main reference ground bus, driven ground rod(s) installed shall have listed ground well box(s) and filled with gravel after connection is made. Interconnect ground rod with structural steel if available and adjacent rods with minimum #4 AWG bare copper conductor. Ground rod shall not be less than 10 foot from any other electrode of another electrical system or from adjacent ground rod(s).
- B. Where ground rods are installed for new bonding and grounding purposes and/or new data racks in existing concrete, contractor shall use ground penetrating radar of the slab prior to installation of ground rod.
- C. Grounding electrode conductor: Provide grounding electrode conductor as indicated on the Drawings or sized per NEC/CEC Article 250, whichever is greater.
- D. Power system grounding:
  - 1. Provide, unless otherwise indicated, a main building power system ground bus mounted on the wall in the main electrical room. Connect the following items using NEC/CEC sized copper grounding conductors to lugs on the main building ground bus:
    - a. Grounding conductor from building reference ground bus in main service switchboard.
    - b. Bonding conductor to metallic cold water piping system.
    - c. Bonding conductor to building structural steel.
    - d. Separately derived system grounding conductors in same room.
    - e. Bonding conductors to each telecom rack, ground bar, or low voltage system connection.
  - 2. At the building power system reference ground bus in the main service switchboard, connect the grounding electrode conductor from concrete encased UFER ground or other grounding electrode systems as indicated on the Drawing or herein.
- E. Equipment bonding/grounding:
  - 1. Provide a NEC/CEC sized insulated copper ground conductor in all 120VAC through 600 VAC feeder and branch circuit distribution conduits and cables.
  - 2. Provide a separate grounding bus at panelboards, switchboards. Connect all metallic enclosed equipment so that with maximum fault current flowing, shall be maintained at not more than 35 volts above ground.
  - 3. Conduit terminating in concentric, eccentric or oversized knockouts at panelboards, cabinets, gutters, etc. shall have grounding bushings and bonding jumpers installed interconnecting all such conduits.
  - 4. Provide bonding jumpers across expansion and deflection couplings in conduit runs, pipe connections to water meters, dielectric couplings in metallic cold water piping system.

5. Provide internal ground wire in flexible conduit connected at each end via grounding bushing.
6. Provide external ground wire wrapped around flexible conduit and terminate to connectors designed for the purpose.

### 3.3 FIELD QUALITY CONTROL

#### A. Prefunctional testing:

1. Visual and mechanical inspection:
  - a. The Contractor and IOR shall inspect the grounding electrode and connections prior to concrete encasement, burial or concealment.
  - b. Check tightness and welds of all ground conductor terminations.
  - c. Verify installation complies with the intent of the Contract Documents
2. Obtain and record ground resistance measurements both from electrical equipment ground bus to the ground electrode and from the ground electrode to earth. Furnish and install additional bonding and add grounding electrodes as required complying with resistance limits specified under this Section of the Specification.
3. A typewritten record of measured resistance values shall be submitted for review.

**END OF SECTION 26 05 26**

## **SECTION 26 05 29 - ELECTRICAL HANGERS AND SUPPORTS**

### **PART 1 - GENERAL**

#### **1.1 SUMMARY**

- A. Work included: Labor, materials and equipment necessary to complete the installation required for the item specified under this Division, including but not limited to:
  - 1. Conduit supports.
  - 2. Equipment supports.
  - 3. Fastening hardware.
- B. Related Work: Consult all other Sections, determine the extent and character of related Work and properly coordinate Work specified herein with that specified elsewhere to produce a complete installation.

#### **1.2 REFERENCES**

- A. Comply with the latest edition of the following applicable Specifications and standards except as otherwise indicated or specified:
  - 1. Underwriters Laboratories, Inc. (UL):  
UL 2239; Hardware for the Supports of Conduit, Tubing and Cable.

#### **1.3 SYSTEM DESCRIPTION**

- A. Provide devices specified in this Section and related Sections for support of electrical equipment furnished and installed under Division 26.
- B. Provide support systems that are adequate for the weight of equipment, conduit and wiring to be supported.

#### **1.4 SUBMITTALS**

- A. Submit in accordance with the requirements of Section 26 00 10: Basic Electrical Requirements, the following items:
  - 1. Data/catalog cuts for each product and component specified herein.
  - 2. Clearly mark on each data sheet the specific item(s) being submitted and the proposed application.
  - 3. Submit Manufacturer's installation instructions.

#### **1.5 QUALITY ASSURANCE**

- A. All materials, equipment and parts comprising the units specified herein shall be new, unused and currently under production.
- B. Only products and applications listed in this Section may be used on the Project unless otherwise submitted.

## PART 2 - PRODUCTS

### 2.1 MANUFACTURERS

- A. Products furnished by the following Manufacturers shall be acceptable if in compliance with all features specified herein and indicated on the Drawings.
  - 1. Concrete fasteners:
    - a. Phillips "Red-Head".
    - b. Remington.
    - c. Ramset.
  - 2. Concrete inserts and construction channel:
    - a. Unistrut Corp.
    - b. GS Metals "Globe Strut."
    - c. Thomas & Betts "Kindorf" Corp.
  - 3. Conduit straps:
    - a. O-Z/Gedney.
    - b. Erico "Caddy" Fastening Products.
    - c. Thomas & Betts "Kindorf" Corp.

### 2.2 CONCRETE FASTENERS

- A. Provide expansion-shield type concrete anchors.
- B. Provide powder driven concrete fasteners with washers. Obtain approval by Architect and Structural Engineer prior to use.

### 2.3 CONCRETE INSERTS

- A. Provide pressed galvanized steel, concrete spot insert, with oval slot capable of accepting square or rectangular support nuts of  $\frac{1}{4}$  inch to  $\frac{1}{2}$  inch diameter thread for rod support.

### 2.4 THREADED ROD

- A. Provide steel threaded rod, sized for the load unless otherwise noted on the Drawings or in the Specifications.

### 2.5 CONSTRUCTION CHANNEL

- A. Provide 1-1/2 inch by 1-1/2 inch, 12 gauge galvanized steel channel with 17/32-inch diameter bolt holes and 1-1/2 inch on center in the base of the channel.

### 2.6 CONDUIT STRAPS

- A. One hole strap, steel or malleable iron, with malleable iron clamp-back spacer for surface mounted wall and ceiling applications.
  - 1. Use malleable strap with spacers for exterior and wet locations.
  - 2. Use steel strap without spacers for interior locations.
- B. Steel channel conduit strap for support from construction channel.

- C. Steel conduit hanger for pendant support with threaded rod
- D. Steel wire conduit support strap for support from independent #12 gauge hanger wires.

### PART 3 - EXECUTION

#### 3.1 EXAMINATION

- A. Contractor shall thoroughly examine Project site conditions for acceptance of supporting device installation to verify conformance with Manufacturer and Specification tolerances. Do not commence with installation until all conditions are made satisfactory.

#### 3.2 PREPARATION

- A. Layout support devices to maintain headroom, neat mechanical appearance and to support the equipment loads.

#### 3.3 INSTALLATION

- A. Furnish and install supporting devices as noted throughout Division 26.
- B. Electrical device and conduit supports shall be independent of all other system supports that are not structural elements of the building, unless otherwise noted.
- C. Fasten hanger rods, conduit clamps, outlet and junction boxes to building structure using precast inserts, expansion anchors, preset inserts or beam clamps.
- D. Use toggle bolts or hollow wall fasteners in hollow masonry, plaster or gypsum board partitions and walls.
- E. Use expansion anchors or preset inserts in solid masonry walls.
- F. Use self-drilling anchors, expansion anchor or preset inserts on concrete surfaces.
- G. Use sheet metal screws in sheet metal studs and wood screws in wood construction.
- H. Do not fasten supports to piping, ductwork, mechanical equipment, conduit or acoustical ceiling suspension wires.
- I. Do not drill structural steel members unless first approved in writing by the Architect or Structural Engineer.
- J. Fabricate supports from structural steel or steel channel, rigidly welded or bolted to present a neat appearance. Use hexagon head bolts with spring lock washers under all nuts.
- K. Install surface-mounted cabinets and panelboards with minimum of four anchors. Provide additional support backing in stud walls prior to sheet rocking as required to adequately support cabinets and panels.
- L. Bridge studs top and bottom with channels to support flush mounted cabinets and panelboards in stud walls.

#### 3.4 ERECTION OF METAL SUPPORTS

- A. Cut, fit and place miscellaneous metal fabrications accurately in location, alignment and elevation to support and anchor electrical materials and equipment.

- B. Field Welding: Comply with AWS "Structural Welding Code."

3.5 WOOD SUPPORTS

- A. Cut, fit and place wood grounds, nailers, blocking and anchorage accurately in location, alignment and elevation to support and anchor electrical materials and equipment.

3.6 ANCHORAGE

- A. All floor mounted, free standing electrical equipment such as telecom racks and electrical equipment, etc. shall be securely fastened to the floor structure.
- B. Anchorage of electrical equipment shall comply with the seismic requirements as outlined in Section 26 00 10: Basic Electrical Requirements.

**END OF SECTION 26 05 29**

## SECTION 26 05 31 - CONDUIT

### PART 1 - GENERAL

#### 1.1 SUMMARY

- A. Work included: Labor, materials and equipment necessary to complete the installation required for the item specified under this Division, including but not limited to:
1. Rigid steel conduit and fittings.
  2. PVC insulated rigid steel conduit and fittings.
  3. Intermediate metal conduit and fittings.
  4. Electrical metallic tubing and fittings.
  5. Flexible metallic conduit and fittings.
  6. Liquidtight flexible metallic conduit and fittings.
  7. Miscellaneous conduit fittings and products.
- B. Related Work: Consult all other Sections, determine the extent and character of related Work and properly coordinate Work specified herein with that specified elsewhere to produce a complete installation.

#### 1.2 REFERENCES

- A. Comply with the latest edition of the following applicable Specifications and standards except as otherwise indicated or specified:
1. Federal Specifications (FS):
    - FS WW-C-563; Electrical Metallic Tubing.
    - FS WW-C-566; Specification for Flexible Metal Conduit.
    - FS WW-C-581; Specification for Galvanized Rigid Conduit.
    - FS W-C-1094A; Conduit and Conduit Fittings Plastic, Rigid.
  2. American National Standards Institute, Inc. (ANSI):
    - ANSI C80.1; Rigid Steel Conduit, Zinc-Coated.
    - ANSI C80.3; Electrical Metallic Tubing, Zinc Coated.
  3. Underwriters Laboratories, Inc. (UL):
    - UL 1; Flexible Metal Conduit.
    - UL 6; Rigid Metal Conduit.
    - UL 360; Liquid-Tight Flexible Steel Conduit.
    - UL 514B; Conduit, Tubing and Cable Fittings.
    - UL 635; Insulating Bushings.
    - UL 797; Electrical Metallic Tubing - Steel.
    - UL 1242; Intermediate Metal Conduit - Steel.
  4. National Electrical Manufacturer Association (NEMA):
    - NEMA RN1; PVC Externally coated Galvanized Rigid Steel Conduit.
    - NEMA TC 2; Electrical Plastic Tubing and Conduit.
    - NEMA TC 3; PVC Fittings for use with Rigid PVC Conduit.
    - NEMA TC 6; PVC Plastic Utilities Duct (EB and DB Type)
    - NEMA TC 9; Fittings for PVC Plastic Utilities Duct (EB and DB Type)

#### 1.3 SUBMITTALS

- A. Submit in accordance with the requirements of Section 26 00 10: Basic Electrical Requirements the following items:



1. Data/catalog cuts for each product and component specified herein, listing all physical and electrical characteristics and ratings indicating compliance with all listed standards.
2. Clearly mark on each data sheet the specific item(s) being submitted and the proposed application.
3. Submit Manufacturer's installation instruction. Provide written instructions for raceway products requiring glues, special tools or specific installation techniques.

#### 1.4 QUALITY ASSURANCE

- A. All materials, equipment and parts comprising the units specified herein shall be new, unused and currently under production.
- B. Only products and applications listed in this Section may be used on the Project unless otherwise submitted and approved.

### PART 2 - PRODUCTS

#### 2.1 MANUFACTURERS

- A. Products furnished by the following Manufacturers shall be acceptable if in compliance with all features specified herein and indicated on the Drawings.
  1. Metal conduit:
    - a. Allied Tube and Conduit Co.
    - b. Triangle PWC, Inc.
    - c. Western Tube and Conduit Corp.
    - d. Spring City Electrical Manufacturing Co.
    - e. Occidental Coating Co. (OCAL).
    - f. Alfex Corp.
    - g. American Flexible Metal Conduit Co.
    - h. Anaconda.
  2. Fittings:
    - a. Appleton Electric Co.
    - b. OZ/Gedney.
    - c. Thomas & Betts Corp.
    - d. Spring City Electrical Manufacturing Co.
    - e. Occidental Coating Co. (OCAL).
    - f. Carlon.

#### 2.2 GALVANIZED RIGID STEEL CONDUIT (GRS)

- A. Conduit: Full weight, threaded, hot-dip galvanized steel, conforming to ANSI C80.1 and UL 6.
- B. Standard threaded couplings, locknuts, bushings and elbows: Only materials of steel or malleable iron are acceptable. Locknuts shall be bonding type with sharp edges for digging into the metal wall of an enclosure.
- C. Three piece couplings: Electroplated, cast malleable iron.
- D. Insulating bushings: Threaded polypropylene or thermosetting phenolic rated 150 degree C minimum.
- E. Insulated grounding bushings: Threaded cast malleable iron body with insulated throat and steel "lay-in" ground lug with compression screw.

- F. Insulated metallic bushings: Threaded cast malleable iron body with plastic insulated throat rated 150 degrees C.
- G. All fittings and connectors shall be threaded.

2.3 PVC INSULATED GALVANIZED RIGID STEEL CONDUIT (PVC GRS)

- A. Conduit: Full weight, threaded, hot-dip galvanized steel, conforming to ANSI C80.1 and NEMA RN-1 with nominal 20 or 40 mil thermoplastic vinyl coating, heat fused and bonded to the exterior of the conduit.
- B. Fittings: Conduit couplings and connectors shall be as specified for galvanized rigid steel conduit and shall be factory PVC coated with an insulating jacket equivalent to that of the coated material.

2.4 INTERMEDIATE METAL CONDUIT (IMC)

- A. Conduit: Hot dip galvanized steel meeting the requirements of NEC Article 345 and conforming to ANSI C80.6 and UL 1242.
- B. Fittings: Conduit couplings, connector and bushing shall be as specified for galvanized rigid steel conduit. Integral retractable type IMC couplings are also acceptable.

2.5 ELECTRICAL METALLIC TUBING (EMT)

- A. Conduit: Shall be formed of cold rolled strip steel, electrical resistance welded continuously along the longitudinal seam and hot dip galvanized after fabrication. Conduit shall conform to ANSI C80.3 Specifications and shall meet UL requirements.
- B. Set screw type couplings: Electroplated, steel or cast malleable iron, UL listed concrete tight. Use set screw type couplings with four setscrews each of conduit sizes over 2 inches. Setscrews shall be of case hardened steel with hex head and cup point to firmly seat in wall of conduit for positive grounding.
- C. Set screw type connectors: Electroplated steel or cast malleable iron UL listed concrete tight with male hub and insulated plastic throat, 150 degree C temperature rated. Setscrew shall be same as for couplings.
- D. Raintight couplings: Electroplate steel or cast malleable iron; UL listed raintight and concrete tight, using gland and ring compression type construction.
- E. Raintight connectors: Electroplated steel or cast malleable iron, UL listed raintight and concrete tight, with insulated throat, using gland and ring compression type construction.

2.6 FLEXIBLE METALLIC CONDUIT (FMC)

- A. Conduit: Shall be fabricated in continuous lengths from galvanized steel strip, spirally wound and formed to provide an interlocking design and conforming to UL 1.
- B. Fittings: Connectors shall be of the single screw clamp variety with steel or cast malleable iron bodies and threaded male hubs with insulated throats. Exception: Pressure cast screw-in connectors shall be acceptable for fixture connection in suspended ceilings and cut-in outlet boxes within existing furred walls.

2.7 LIQUIDTIGHT FLEXIBLE METALLIC CONDUIT (LFMC)

- A. Conduit: Shall be fabricated in continuous lengths from galvanized steel strips, interlocking spirally wound, covered with extruded liquidtight jacket of polyvinyl chloride (PVC) and conforming to UL 360. Provide conduit with a continuous copper-bonding conductor wound spirally between the convolutions.
- B. Fittings: Connector body and gland nut shall be of cadmium plated steel or cast malleable iron, with tapered, male, threaded hub; insulated throat and neoprene "O" ring gasket recessed into the face of the stop nut. The clamping gland shall be of molded nylon with an integral brass push-in ferrule.

2.8 MISCELLANEOUS CONDUIT FITTINGS AND PRODUCTS

- A. Watertight conduit entrance seals: Steel or cast malleable iron bodies and pressure clamps with PVC sleeve, neoprene sealing grommets and PVC coated steel pressure rings. Fittings shall be supplied with neoprene sealing rings between the body and PVC sleeve.
- B. Watertight cable sealing bushings: One piece, compression molded sealing ring with PVC coated steel pressure disks, stainless steel sealing screws and zinc plated cast malleable iron locking collar.
- C. Expansion fittings: Multi-piece unit comprised of a hot dip galvanized malleable iron or steel body and outside pressure bussing designed to allow a maximum of 4" conduit movement (2" in either direction). Furnish with external braid tinned copper bonding jumper. Unit shall be UL listed for wet or dry locations.
- D. Expansion/deflection couplings: Multi-piece unit comprised of a neoprene sleeve with internal flexible tinned copper braid attached to bronze end couplings with stainless steel bands. Coupling shall accommodate .75-inch deflection, expansion or contraction in any direction and allow 30-degree angular deflections. Flexible, corrosion-resistant, watertight, moisture and heat resistant molded rubber jacket and stainless steel jacket clamps. Unit shall comply with UL467 and UL514. Manufacturer shall be OZ/Gedney Type DX, Steel City Type EDF or equal.
- E. Fire rated penetration seals:
  - 1. UL building materials directory classified.
  - 2. Conduit penetrations in fire rated separation shall be sealed with a UL classified fill, void or cavity material.
  - 3. The fire rated sealant material shall be the product best suited for each type of penetration and may be a caulk, putty, composite sheet or wrap/strip.
- F. Standard products not herein specified:
  - 1. Provide listing of standard electrical conduit hardware and fittings not herein specified for approval prior to use or installation, i.e. locknuts, bushings, etc.
  - 2. Listing shall include Manufacturers name, part numbers and a written description of the item indicating type of material and construction.
  - 3. Miscellaneous components shall be equal in quality, material and construction to similar items herein specified.

### PART 3 - EXECUTION

#### 3.1 EXAMINATION

- A. Contractor shall thoroughly examine Project site conditions for acceptance of conduit system installation to verify conformance with Manufacturer and Specification tolerances. Do not commence with installation until all conditions are made satisfactory.

#### 3.2 APPLICATION

- A. Galvanized rigid steel conduit (GRS) shall be used in the following applications:
1. For feeders and branch circuits located indoors, concealed or exposed above suspended ceilings, in damp/wet locations, in crawl spaces, in attics, chases, furred spaces, equipment rooms, loading docks or in hazardous locations in accordance with NEC and local Codes.
  2. For feeders and branch circuits concealed in concrete floors and walls when not in contact with earth.
- B. PVC insulated galvanized rigid steel conduit shall be used in the following applications:
1. Use 40-mil coating for feeders and branch circuits in damp or wet locations.
  2. Use 20 or 40 mil for feeders and branch circuits concealed in concrete walls or slabs in contact with earth.
  3. Use 20 or 40-mil for runs beneath floor slabs on grade.
  4. Use 40-mil for all below grade penetrations through floor slabs on grade or exterior walls.
- C. Intermediate metal conduit (IMC): Shall be used for the same application as galvanized rigid steel conduit as specified herein, except for hazardous locations prohibited by CEC, NEC or Local Codes.
- D. Electrical metallic tubing (EMT): Shall be used exposed or concealed for interior electrical feeders 4" and smaller, interior power and lighting branch circuits and low tension distribution system where run above suspended ceilings, in concrete slabs and walls not in contact with earth; in stud walls, furred spaces and crawl spaces. EMT shall not be installed exposed below 6 feet above the finish floor except within electrical, communication or signal rooms or closets.
- E. Flexible metallic conduit (FMC): Shall be used only in dry locations for connections from an adjacent outlet box or conduit to all motors, transformers, vibrating equipment or machinery, controllers, solenoid valves, float and flow switches or similar devices and to lighting fixtures installed in suspended ceilings, minimum sizes shall be 3/8" for lighting fixtures and control wiring and 1/2" for motor and transformer connections. U.O.N.
- F. Liquidtight flexible metallic conduit (LFMC): Shall be used in wet or damp locations for connections from adjacent outlet box or conduit to all motors, transformers, vibrating equipment or machinery, controllers, solenoid valves, float and flow switches or similar devices. These areas are typically food preparation and dishwashing areas, sump wells, loading docks, pump rooms, exterior areas, etc. Minimum sizes shall be 1/2".

#### 3.3 PREPARATION

- A. Locations of conduit runs shall be planned in advance of the installation and coordinated with ductwork, plumbing, ceiling and wall construction in the same areas and shall not unnecessarily cross other conduits or pipe, nor prevent removal of ceiling tiles or panels, nor block access to mechanical or electrical equipment.

- B. Where practical, install conduits in groups in parallel vertical or horizontal runs and at elevations that avoid unnecessary offsets.
- C. All conduits shall be run parallel or at right angles to the centerlines of columns and beams, whether routed exposed, concealed above suspended ceiling or in concrete slabs.
- D. Conduits shall not be placed closer than 12 inches to a flue, parallel hot water, steam line or other heat producing source or three inches from such lines when crossing perpendicular to the runs.
- E. Exposed conduit installation shall not encroach into the ceiling height headroom of walkways or doorways. Where possible, install horizontal raceway runs above water and below steam piping.
- F. The largest trade size conduits in concrete floor and wall slabs shall not exceed 1/3 the floor or wall thickness and conduits shall be spaced a minimum of three conduit diameters apart unless otherwise noted on the Drawings. All conduits shall be installed in the center of concrete slabs or wall and shall not be placed between reinforcing steel and the bottom of floor slabs.
- G. In long runs of conduit, provide sufficient pull boxes inside buildings to facilitate pulling wires and cables, with spacing not to exceed 150 feet. Support pull boxes from structure independent of conduit supports. These pull boxes are not indicated on the Drawings.
- H. Provide all reasonably inferred standard conduits fitting and products required to complete conduit installation to meet the intended application whether noted, indicated or specified in the Contract Documents or not.
- I. Connect recessed lighting fixtures to conduit runs with maximum six feet of flexible metal conduit or MC cable extending from a junction box to the fixture or manufactured wiring system.

### 3.4 INSTALLATION

- A. Install conduit in accordance with Manufacturer's written instructions, as indicated on Drawings and as specified herein.
- B. Minimum Conduit Size: Unless otherwise noted herein or on Drawings, minimum conduit size shall be 1/2" for interior applications and 3/4" for exterior and underground applications.
- C. All conduit sizes indicated on the Drawings are sized for copper conductors with THHN/THWN insulation. If conductor type or size is changed the Contractor shall be responsible for resizing conduits upward to meet Code.
- D. In general, all conduit work shall be concealed where possible. Exceptions shall be electrical, communication and mechanical rooms, exposed ceiling areas, and parking garages.
- E. Conduit connections to motors and surface cabinets shall be concealed, with the exception of electrical, communication and mechanical rooms, or unless exposed Work is clearly called for on the Drawings.
- F. Install conduits in complete runs before pulling in cables or wires.
- G. Install conduit free from dented, bruises or deformations. Remove and replace any damaged conduits with new undamaged material.
- H. Conduits shall be well protected and tightly covered during construction using metallic bushings and bushing "pennies" to seal open ends.

- I. In making joints in rigid steel conduit, ream conduit smooth after cutting and threading. Coat all field-threaded joints with UL approved conductive type compound to ensure low resistance ground continuity through conduit and to prevent seizing and corrosion.
- J. Clean any conduit in which moisture or any foreign matter has collected before pulling in conductors. Paint all field-threaded joints to prevent corrosion.
- K. In all empty conduits or ducts, install a "True Tape" conduit measuring tape line to provide overall conduit length for determining length of cables/conductors for future use.
- L. Conduit systems shall be mechanically and electrically continuous throughout. Install code size, insulated, copper, green-grounding conductors in all conduit runs for branch circuits and feeders. This conductor is not indicated on the Drawings. Refer to Section 26 05 26: Grounding and Bonding.
- M. Metallic conduit shall not be in contact with other dissimilar metal pipes (i.e. plumbing).
- N. Make bends with standard conduit bending hand tool or machines. The use of any item not specifically designed for the bending of electrical conduit is strictly prohibited.
- O. A run of conduit between terminations at wire pulling points shall not contain more than the equivalent of four quarter bends (360 degrees, total).

### 3.5 PENETRATIONS

- A. Locate penetrations and holes in advance where they are proposed in the structural sections such as footings, beams, wall, etc. Penetrations are acceptable only when the following occurs:
  - 1. As approved by the Structural Engineer prior to construction and after submittal of Drawing showing location, size and position of each penetration.
- B. Cutting or holes:
  - 1. Cut holes through concrete, masonry block or brick floors and floors of structure with a diamond core drill or concrete saw. Pneumatic hammer, impact electric, hand or manual hammer type drills are not allowed, except where permitted by the Structural Engineer as required by limited working space. Obtain the approval of the Structural Engineer prior to drilling through structural sections.
  - 2. Provide sleeves or "can outs" for cast-in-place concrete floors and walls. Following conduit installation, seal all penetrations using non-iron bearing, chloride free, non-shrinking, dry-pack grouting compounds; or fire rated penetration-sealing materials.
  - 3. Cut holes for conduit penetrations through non-concrete and non-masonry walls, partitions or floors with a hole saw. The hole shall be only as large as required to accommodate the size of the conduit.
  - 4. Provide single piece escutcheon plates around all exposed conduit penetrations in public places.
- A. Sealing:
  - 5. Non-rated penetrations: Pack opening around conduits with non-flammable insulating material and seal with gypsum wallboard taping compound.
  - 6. Fire stop: Where conduits, wireways and other electrical raceways pass through fire rated partitions, walls, smoke partitions or floor; install a UL classified fire stop material to provide an effective barrier against the spread of fire, smoke and gases. Completely fill and seal clearances between raceways and openings with the fire stop material.

- C. Waterproofing: At floor, exterior wall and roof conduit penetrations, completely seal clearances around the conduit and make watertight as specified in Division 07: Sealants and Caulking.
  - 1. Install specified watertight conduit entrance seals at all below grade wall and floor penetrations. Conduits penetrating exterior building walls and building floor slab shall be PVC coated rigid galvanized steel.
  - 2. For roof penetrations furnish and install roof flashing, counter flashing and pitch-pockets as specified under Roofing and Sheet Metal Sections of the Specifications.
  - 3. Provide membrane clamps and cable sealing fittings for any conduit that horizontally penetrates the waterproof membrane.
  - 4. Conduits that horizontally penetrate a waterproof membrane shall fall away from and below the penetration on the exterior side a minimum of two times the conduit diameters.

### 3.6 TERMINATIONS AND JOINTS

- A. Use raceway fittings that are of types compatible with the associated raceway and suitable for the use and location. For intermediate steel conduit, use threaded rigid steel conduit fittings except as otherwise indicated.
- B. Raceways shall be joined using specified couplings or transition couplings where dissimilar raceway systems are joined.
- C. Conduits shall be securely fastened to cabinets, boxes and gutters using two locknuts and an insulating bushing or specified insulated connectors. Where joints cannot be made tight, use bonding jumpers to provide electrical continuity of the raceway system. Where terminations are subject to vibration, use bonding bushings or wedges to assure electrical continuity. Where subject to vibration or dampness, use insulating bushings to protect conductors. Install grounding bushings or bonding jumpers on all conduits terminating at concentric or eccentric knockouts.
- D. Conduit terminations exposed at weatherproof enclosures and cast outlet boxes shall be made watertight using specified connectors and hubs.
- E. Install specified cable sealing bushings on all conduits originating outside the building walls and terminating in switchgear, cabinets or gutters inside the building. Install cable sealing bushings or raceway seal for conduit terminations in all grade level or below grade exterior pull, junction or outlet boxes.
- F. Install expansion couplings where any conduit crosses a building separation or expansion joint as follows:
  - 1. Conduits three inches and larger, shall be rigidly secured to the building structure on opposite sides of a building expansion joint and provided with expansion or deflection couplings. Install the couplings in accordance with the Manufacturer's recommendations.
  - 2. Conduits smaller than three inches shall be rigidly secured to the building structure on opposite sides of a building expansion joint with junction boxes on both sides of the joint. Connect conduits to junction boxes with 15 inches of slack flexible conduit. Flexible conduit shall have a copper green ground-bonding jumper installed. For concrete embedded conduit, use expansion and deflection couplings as specified above for three inches and larger conduits.
- G. Use short length (maximum of 6ft) of the appropriate FMC or LFMC conduit for connections to motors and other electrical equipment subject to movement, vibration, misalignment, cramped quarters or noise transmission. Provide liquidtight flexible metal conduit for installation in exterior locations, moisture or humidity-laden atmosphere, corrosive atmosphere, water hose or spray wash-down operations and locations subject to seepage or dripping of oil, grease or water. Provide a green ground wire with FMC or LFMC conduit.

3.7 SUPPORTS

- A. Provide supports for raceways as specified in Section 26 05 29: Electrical Hangers and Supports.
- B. All raceways systems shall be secured to building structures using specified fasteners, clamps and hangers spaced according to the NEC.
- C. Support single runs of conduit using one-hole pipe straps. Where run horizontally on walls in damp or wet locations, install "clamp backs" to space conduit off the surface.
- D. Multiple conduit runs shall be supported using "trapeze" hangers fabricated from specified construction channel, mounted to 3/8-inch diameter, threaded steel rods secured to building structures. Fasten conduit to construction channel with standard one-hole pipe clamps or the equivalent. Provide lateral seismic bracing for hangers.
- E. Individual 1/2" and 3/4" conduits installed above suspended ceilings may be attached to the ceiling's hanger wire using spring steel support clips provided that not more than two conduits are attached to any single support wire.
- F. Support exposed vertical conduit runs at each floor level, independent of cabinets or switches to which they run, by means of acceptable supports.
- G. Fasteners and supports in solid masonry and concrete:
  - 1. Use steel or malleable iron concrete inserts set in place prior to placing the concrete.
  - 2. After concrete installation:
    - a. Steel expansion anchors not less than ¼ inch bolt size and not less than 1-1/8 inch embedment.
    - b. Power set fasteners not less than ¼ inch diameter with depth of penetration not less than three inches.
    - c. Use vibration and shock resistant anchors and fasteners for attaching to concrete ceilings.
- H. Metal structures: Use machine screw fasteners or other devices specifically designed and approved for the application.

**END OF SECTION 26 05 31**



## SECTION 26 05 33 - BOXES

### PART 1 - GENERAL

#### 1.1 SUMMARY

- A. Work included: Labor, materials and equipment necessary to complete the installation required for the item specified under this Division, including but not limited to:
  - 1. Wall and ceiling outlet boxes.
  - 2. Pull and junction boxes.
- B. Related Work: Consult all other Sections, determine the extent and character of related Work and properly coordinate Work specified herein with that specified elsewhere to produce a complete installation.

#### 1.2 REFERENCES

- A. Comply with the latest edition of the following applicable Specifications and standards except as otherwise indicated or specified.
  - 1. American National Standards Institute/National Electrical Manufacturer Association:
    - ANSI/NEMA OS-1; Sheet-Steel Outlet Boxes, Device Boxes, Covers and Box Supports.
    - ANSI/NEMA OS-2; Nonmetallic Outlet Boxes, Device Boxes, Covers and Box Supports.
    - NEMA 250; Enclosures for Electrical Equipment (1000 volts maximum).
  - 2. Underwriters Laboratories (UL):
    - UL 50; Enclosures for Electrical Equipment.
    - UL 514A; Metallic Outlet Boxes.
    - UL 1773; Termination Boxes.

#### 1.3 SUBMITTALS

- A. Submit in accordance with the requirements of Section 26 00 10: Basic Electrical Requirements, the following items:
  - 1. Data/catalog cuts for each product and component specified herein, listing all physical and electrical characteristics and ratings indicating compliance with all listed standards.
  - 2. Clearly mark on each data sheet the specific item(s) being submitted and the proposed application.
  - 3. Submit Manufacturer's installation instructions.

#### 1.4 QUALITY ASSURANCE

- A. All materials, equipment and parts comprising the units specified herein shall be new, unused and currently under production.
- B. Only products and applications listed in this Section may be used on the Project unless otherwise submitted.

## PART 2 - PRODUCTS

### 2.1 MANUFACTURERS

- A. Products furnished by the following Manufacturers shall be acceptable if in compliance with all features specified herein and indicated on the Drawings.
1. Outlet and junction boxes:
    - a. Spring City Electrical Manufacturing Co.
    - b. Thomas & Betts Corp.
    - c. Raco, Inc.
  2. Cast boxes:
    - a. Appleton Electric Co.
    - b. Crouse-Hinds.
  3. Pullboxes:
    - a. Circle AW Products.
    - b. Hoffman Engineering Co.

### 2.2 OUTLET BOXES

- A. Standard outlet box:
1. Provide galvanized, one-piece die formed or drawn steel, knockout type box of size and configuration best suited to the application indicated on the Drawings.
  2. 4-inch square by 1-1/2 inch deep shall be minimum box size.
  3. ANSI/NEMA OS 1.
- B. Concrete box:
1. Provide galvanized steel, 4-inch octagon rings with mounting lugs, backplate and adapter ring as required.
  2. Select height as necessary to position knockouts above concrete reinforcing steel.
  3. ANSI/NEMA OS 1.
- C. Tile box:
1. Provide outlet boxes for installation in tile or concrete block walls.
  2. Standard outlet boxes with raised, square corners and device covers are acceptable.
  3. ANSI/NEMA OS 1.
- D. Cast metal outlet body:
1. Provide four inch round, galvanized cast iron alloy with threaded hubs and mounting lugs as required.
  2. Provide boxes with cast cover plates of the same material as the box and neoprene cover gaskets.
- E. Conduit outlet body: Provide Cadmium plated cast iron alloy, oblong conduit outlet bodies with threaded conduit hubs and neoprene gasket, cast iron covers.

## 2.3 PULL AND JUNCTION BOXES

- A. Sheet metal pull and junction box:
  - 1. Provide standard outlet or concrete ring boxes wherever possible; otherwise use minimum 16 gauge galvanized sheet metal, NEMA 1 boxes, sized to Code requirements with covers secured by cadmium plated machine screws located 6 inches on centers.
  - 2. ANSI/NEMA OS 1.
- B. Cast metal pull and junction box: Provide standard cast malleable iron outlet or device boxes wherever possible; otherwise use cadmium plated, cast malleable iron boxes with bolt-on, interchangeable conduit hub plates with neoprene gaskets.
- C. Flush mounted pullboxes and junction boxes: Provide overlapping covers with flush head cover retaining screws, prime coated.

## PART 3 - EXECUTION

### 3.1 EXAMINATION

- A. Contractor shall thoroughly examine Project site conditions for acceptance of box installation to verify conformance with Manufacturer and Specification tolerances. Do not commence with installation until all conditions are made satisfactory.

### 3.2 PREPARATION

- B. Install all outlet boxes flush with building walls, ceilings and floors except where boxes are installed in mechanical and electrical rooms, in cabinetry, above accessible ceilings or where exposed Work is called for on the Drawings.
- C. Locate pullboxes and junction boxes in concealed locations above removable ceilings or exposed in electrical rooms, utility rooms or storage areas.
- D. Install outlet boxes at the locations and elevations indicated on the Drawings or specified herein. Make adjustments to locations as required by structural conditions and to suit coordination requirements of other trades.
- E. Locate switch outlet boxes on the latch side of doorways unless otherwise indicated.
- F. Locate outlet boxes above hung ceilings having concealed suspension systems, adjacent to openings for removable recessed lighting fixtures.
- G. Do not install outlet boxes back-to-back, separate boxes by at least 6". In fire rated walls separate boxes by at least 24" and wall stud.
- H. Adjust position of outlet boxes in finished masonry walls to suit masonry course lines. Coordinate cutting of masonry walls to achieve neat openings for boxes.

### 3.3 INSTALLATION

- I. Install boxes in accordance with Manufacturer's written instructions, as indicated on Drawings and as specified herein.
- J. Locate electrical boxes as indicated on Drawings and as required for splices, taps, wire pulling, equipment connections and Code compliance.

- K. Install junction or pullboxes where required to limit bends in conduit runs to not more than 360 degrees or where pulling tension achieved would exceed the maximum allowable for the cable to be installed. Note that these boxes are not indicated on the Drawings.
- L. Install raised covers (plaster rings) on all outlet boxes in stud walls or in furred, suspended or exposed concrete ceilings. Covers shall be of a depth to suit the wall or ceiling finish.
- M. Leave no unused openings in any box. Install close-up plugs as required to seal openings.
- N. Provide cast metal boxes with gasketed cast metal cover plates where boxes are exposed in damp or wet locations.
- O. Provide an access panel in permanent ceiling or wall where boxes are installed and will be inaccessible.
- P. For boxes mounted in exterior walls, make sure that there is insulation behind outlet boxes to prevent condensation in boxes.
- Q. For outlets mounted above counters, benches or backsplashes, coordinate location and mounting heights with built-in units. Adjust mounting height to agree with required location for equipment served.
- R. Use conduit outlet bodies to facilitate pulling of conductors or to make changes in conduit direction only. Do not make splices in conduit outlet bodies.
- S. Add additional sheet rock as necessary to maintain original fire rating of walls where boxes are installed.
- T. Install galvanized steel coverplates on boxes in unfinished areas, above accessible ceilings and on surface mounted outlets.

#### 3.4 SUPPORTS

- U. Provide boxes installed in metal stud walls with brackets designed for attaching directly to the studs or mount boxes on specified box supports.
- V. Mount boxes, installed in suspended ceilings of gypsum board or lath and plaster construction, to 16 gauge metal channel bars attached to main ceiling runners.
- W. Support boxes independently of conduit system.
- X. Support boxes, installed in suspended ceilings supporting acoustical tiles or panels, directly from the structure above wherever pendant mounted lighting fixtures are to be installed from the box.
- Y. Support boxes, mounted above suspended acoustical tile ceilings, directly from the structure above.

**END OF SECTION 26 05 33**

## **SECTION 26 05 53 - ELECTRICAL IDENTIFICATION**

### **PART 1 - GENERAL**

#### **1.1 SUMMARY**

- A. Work included: Labor, materials and equipment necessary to complete the installation required for the item specified under this Division, including but not limited to:
  - 1. Electrical equipment nameplates.
  - 2. Panelboard directories.
  - 3. Wire and cable identification.
  - 4. Junction box identification.
  - 5. Warning and caution signs.
  - 6. Inscribed device coverplates.
- B. Related Work: Consult all other Sections, determine the extent and character of related Work and properly coordinate Work specified herein with that specified elsewhere to produce a complete installation.

#### **1.2 SUBMITTALS**

- C. Submit in accordance with the requirements of Section 26 00 10: Basic Electrical Requirements, the following items:
  - 1. Data/catalog cuts for each product and component specified herein.
  - 2. Schedules for nameplates to be furnished.

### **PART 2 - PRODUCTS**

#### **2.1 MANUFACTURERS**

- A. Products furnished by the following Manufacturers shall be acceptable if in compliance with all features specified herein and indicated on the Drawings.
  - 1. Conduit and wire markers:
    - a. Thomas & Betts Corp.
    - b. Brady.
    - c. Griffolyn.
  - 2. Inscription Tape:
    - a. Kroy.
    - b. Merlin.

#### **2.2 NAMEPLATES**

- A. Type NP: Engraved, plastic laminated labels, Signs and Instruction Plates. Engrave stock melamine plastic laminate 1/16-inch minimum thickness for signs up to 20 square inches or 8 inches in length; 1/8 inch thick for larger sizes. Engraved nameplates shall have white letters and be punched for mechanical fasteners.
- B. Color and letter height as specified in Part 3: Execution.

## 2.3 LEGEND PLATES

- A. Type LP: Die-stamped metal legend plate with mounting hole and positioning key for panel mounted operator devices, i.e. motor control pilot devices, hand-off-auto switches, reset buttons, etc.
- B. Stamped characters to be paint filled.

## 2.4 BRASS TAGS

- A. Type BT: Metal tags with die-stamped legend, punched for fastener.
- B. Dimensions: 2" diameter 19 gauge.

## 2.5 PANELBOARD DIRECTORIES (400 amp or less)

- A. Directories: A 6" x 8" minimum size circuit directory frame and card with clear plastic covering shall be provided inside the inner panel door.
- B. Circuit numbering: Starting at the top, odd numbered circuits in sequence down the left hand side and even numbered circuits down the right hand side. Multi-section panelboards shall have continuous consecutive circuit numbers, i.e. Section 1 (circuit numbers 1-42), Section 2 (circuit numbers 43-84), Section 3 (circuit numbers 85-126).

## 2.6 WIRE AND TERMINAL MARKERS

- A. Provide self-adhering, pre-printed, machine printable or write-on, self-laminating vinyl wrap around strips. Blank markers shall be inscribed using the printer or pen recommended by Manufacturer for this purpose.

## 2.7 CONDUCTOR PHASE MARKERS

- A. Colored vinyl plastic electrical tape, 3/4" wide, for identification of phase conductors. Scotch 35 Brand Tape or equal.

## 2.8 UNDERGROUND CONDUIT MARKER

- A. 6-inch wide, yellow polyethylene tape, with continuous black imprinting reading "Caution - Buried Electric Line Below".

## 2.9 INSCRIBED DEVICE COVERPLATES

- A. Coverplate material shall be as specified in Section 26 27 26: Wiring Devices.
- B. Methods of inscription: (Unless otherwise noted)
  - 1. Type-on-tape:
    - a. Imprinted or thermal transfer characters onto tape lettering system.
    - b. Tape trimmer.
    - c. Matte finish spray-on clear coating.
  - 2. Engraving:
    - a. 1/8" high letters.
    - b. Paint filled letters finished in black.

## PART 3 - EXECUTION

### 3.1 EXAMINATION

- A. Contractor shall thoroughly examine Project site conditions for acceptance of identification device installation to verify conformance with Manufacturer and Specification tolerances. Do not commence with installation until all conditions are made satisfactory.

### 3.2 NAMEPLATES

#### A. Installation:

1. Degrease and clean surfaces to receive nameplates.
2. Install nameplates parallel to equipment lines.
3. Secure nameplates to equipment fronts using machine screws.

#### B. Provide type 'NP' color coded nameplates that present, as applicable, the following information:

##### 1. Equipment or device designation:

###### a. Equipment designations shall conform to the following:

- 1) Building number designation – 00.
- 2) Power source:
  - a) Normal - \_\_
  - b) Emergency – E
  - c) UPS – U
- 3) Equipment description:
  - a) Primary substation – PS
  - b) Secondary substation – SS
  - c) Main switchboard – MS
  - d) 120/208 volt distribution board – LD
  - e) 120/208 volt panelboard – L
  - f) Transformer – TX
  - g) Motor control center – MCC
- 4) Floor number where equipment is located – 3
- 5) Equipment designation – B

###### b. Example: 06EHD2A

- 1) Building number 06.
- 2) Emergency source.
- 3) 2<sup>nd</sup> floor.
- 4) Board designation A

##### 2. Amperage, KVA or horsepower rating, where applicable.

##### 3. Voltage or signal system name.

##### 4. Source of power or control.

##### 5. Examples:

- a. Boards: 06EHD2A; 1200A; 277/480V, 3PH, 4W; Served from: 06ATS1A
- b. Transformers: 06ETX2A; 150KVA; 480V pri. - 120/208V, 3PH, 4W sec.; Served from: 06EHD2A; Load Served: 06EL2A

- c. Motor Control Centers:
    - 1) Main nameplate: 06MCC1A; 600A Main Bus; 480V,3PH,3W; Served from 06HD1A
    - 2) Each compartment: EF-1; 20 HP; 100A Switch; Size 1 Starter
  - d. Disconnects or Individual Motor Starters: EF-1; 20HP; 480V,3PH,3W; Served from 06MCC1A
  - e. Signal: 06STB3C; Public Address System; Served from 06STB2C
- C. Nameplates for power system distribution equipment and devices are to be black.
- D. Nameplates for signal systems equipment and devices are to be black except as follows:
- 1. Fire alarm and life safety - Red.
  - 2. Security/card access/CCTV systems - Green.
  - 3. Clock, intercom, sound, MATV, CATV - Blue.
- E. Minimum letter height shall be as follows:
- 1. For panelboards, switchboards, battery panels motor control center, etc.: ½ inch letters to identify equipment designation. Use ¼ inch letters to identify voltage, phase, wires, etc.
  - 2. For individual circuit breakers, switches and motor starters in panelboards, switchboards and motor control centers use 3/8-inch letters to identify equipment designation. Use 1/8-inch letters to identify all other.
  - 3. For individual mounted circuit breakers, disconnect switches, enclosed switches and motor starters use 3/8-inch letters to identify equipment designation. Use 1/8" letters to identify all other.
  - 4. For transformers use 1/2 inch letters to identify equipment designation. Use ¼ inch letters to identify primary and secondary voltages, etc.
  - 5. For equipment cabinets, terminal cabinets, control panels and other cabinet enclosed apparatus use 3/8-inch letters to identify equipment designation.

### 3.3 LEGEND PLATES

- A. Provide panel-mounted operators devices such as pilot lights, reset buttons, "HAND-OFF-AUTO" switches, etc.

### 3.4 BRASS TAGS

- A. Provide type BT tags for individual ground conductors to exposed ground bus indicating connection i.e. "UFER", "Cold water bond", etc.
- B. Provide tags for all feeder cables in underground vaults and pull boxes.
- C. Provide tags for empty conduits in underground vault, pull boxes and stubs.

### 3.5 PANELBOARD DIRECTORIES (400 AMP OR LESS)

- A. Provide typewritten directories arranged in numerical order denoting loads served by room number or area for each circuit.
- B. Verify room numbers or area designation with Project Manager.
- C. Mount panelboard directories in a minimum 6" x 8" metal frame under clear plastic cover inside every panelboard.



### 3.6 WIRE AND CABLE IDENTIFICATION

- A. Provide wire markers on each conductor in panelboards, pull boxes, outlet and junction boxes and at load connection. Identify with branch circuit or feeder number for power and lighting circuits and with control wire number as indicated on equipment Manufacturer's Shop Drawings for control wiring.
- B. Provide colored phase markers for conductors as noted in Section 26 05 19: Building Wire and Cable. Apply colored, pressure sensitive plastic tape in half-lapped turns for a distance of 3 inches from terminal points and in boxes where splices or taps are made. Apply the last two laps of tape with no tension to prevent possible unwinding. Do not cover cable identification markings by taping.

### 3.7 UNDERGROUND CONDUIT MARKERS

- A. During trench backfilling, for exterior underground power, signal and communications lines, install continuous underground plastic line marker, located directly above line at 6 to 8 inches below finished grade. Where multiple lines installed in a common trench or concrete envelope, do not exceed an overall width of 16 inches; install a single line marker.

### 3.8 JUNCTION BOX IDENTIFICATION

- A. The cover of junction, pull and connection boxes for both power and signal systems, located above suspended ceilings and below ceilings in non-public areas, shall be clearly marked with a permanent ink felt pen. Identify the circuit(s) (panel designation and circuit numbers) contained in each box, unless otherwise noted or specified.

### 3.9 WARNING, CAUTION AND INSTRUCTION SIGNS

- A. Provide warning, caution or instruction signs where required by NEC, where indicated or where reasonably required to assure safe operation and maintenance of electrical systems and of the items to which they connect. Install engraved plastic laminated instruction signs with approved legend where instructions or explanations are needed for system or equipment operation. Install butyrate signs with metal backing for outdoor items.

### 3.10 INSCRIBED DEVICE COVERPLATE

- A. General:
  - 1. Lettering type: Helvetica, 12 point or 1/8" high.
  - 2. Color of characters shall be black.
  - 3. Locate the top of the inscription 1/2" below the top edge of the coverplate.
  - 4. Inscription shall be centered and square with coverplate.
- B. Application:
  - 1. Provide inscribed coverplates for devices as outlined below:
    - a. Receptacles.
    - b. Outlets in surface raceways.
    - c. Multi-ganged (four or more) switch arrangement.
    - d. Special purpose switches, i.e. projection screens, shades, exhaust fans, etc.
    - e. Telecommunication outlets.
  - 2. Type-on-tape inscriptions shall be provided for the following devices:
    - a. Receptacles.

- b. Outlets in surface raceways.
  - c. Telecommunication outlets.
3. Engraved inscriptions shall be provided for the following devices:
- a. Multi-ganged switches.
  - b. Special purpose switches.
4. Type-on-tape installation:
- a. Tape shall be trimmed to the height of the letters.
  - b. Trim tape length to 1/4 inch back from each edge of coverplate.
  - c. Contractor hands shall be clean or covered with surgical type glove prior to application of tape. Tape installations with visible fingerprints or smudges will not be acceptable.

**END OF SECTION 26 05 53**

## SECTION 26 09 26 – LOW-VOLTAGE LIGHTING CONTROL

### PART 1 - GENERAL

#### 1.1 SUMMARY

- A. Work included: Labor, materials and equipment necessary to complete the installation required for the item specified under this Division, including but not limited to:
1. Room controllers or network power/relay packs.
  2. Wallbox dimmers and switches.
  3. Occupancy sensors.
  4. Daylight sensors.
  5. Receptacle control device.
  6. I/O modules.
  7. Relay panel.
  8. Emergency lighting control.
  9. Network components and cabling.
  10. System software.
  11. Astronomical Time Clock.
- B. Related Work: Consult all other Sections, determine the extent and character of related Work and properly coordinate Work specified herein with that specified elsewhere to produce a complete installation.

#### 1.2 REFERENCES

- A. Comply with the latest edition of the following applicable Specifications and standards except as otherwise indicated or specified:
1. National Electrical Manufacturer Association (NEMA):
    - NEMA 250; Enclosures for Electrical Equipment.
    - NEMA ICS 1; Industrial Control and Systems.
    - NEMA ICS 4; Terminal Blocks and Industrial use.
    - NEMA ICS 6; Enclosures for Industrial Controls and Systems.
  2. Underwriters Laboratories, Inc. (UL):
    - UL 50; Cabinets and Boxes.
    - UL 773A; Nonindustrial Photoelectric Switches for Lighting Control.
    - UL 916; Energy Management.

#### 1.3 SYSTEM DESCRIPTION

- A. Provide a complete lighting control system consisting of stand-alone components, capable of being networked together enabling digital communication. Devices shall be individually addressable.
- B. The lighting control system shall provide time-based, sensor-based (occupancy, daylighting), and manual (on/off, dimming) lighting control.
- C. The system architecture shall be capable of enabling stand-alone groups (rooms) of devices to function in some default capacity even if network connectivity to the greater system is lost.
- D. The system shall not require any centrally hardwired switching equipment.
- E. The system shall be capable of wireless, wired, or hybrid wireless/wired architectures.

- F. Space Control Requirements: Unless otherwise noted on the plans, provide a minimum application of lighting controls as follows:
1. Provide occupancy/vacancy sensors with Manual or Partial ON functionality in all spaces except toilet rooms, storerooms, library stacks, or other applications where hands-free operation is desirable and Automatic ON occupancy sensors are more appropriate. Provide Manual ON occupancy sensors for any enclosed office, conference room, meeting room, or classroom. For spaces with multiple occupants, or where line-of-sight may be obscured, provide ceiling- or corner-mounted sensors and Manual-ON switches.
  2. Daylit Areas – Provide daylight-responsive automatic control in all spaces (conditioned or unconditioned) where daylight contribution is available as defined by the 2016 Building Energy Efficiency Standards :
    - a. All luminaires within each code-defined primary and secondary daylight zone or skylit zone shall be controlled separately from luminaires.
    - b. Daytime setpoints for total ambient illumination (combined daylight and electric light) levels that initiate dimming shall be programmed in compliance with relevant local building energy codes.
    - c. Multiple-leveled switched daylight harvesting controls may be utilized for areas marked on drawings.
    - d. Provide smooth and continuous daylight dimming for areas marked on drawings. Daylighting control system may be designed to turn off electric lighting when daylight is at or above required lighting levels, only if system functions to turn lamps back on at dimmed level, rather than turning full-on prior to dimming.
  3. Spaces with moveable walls shall include controls that can be reconfigured when the room is partitioned.

#### 1.4 SUBMITTALS

- A. Submit in accordance with the requirements of Section 26 00 10: Basic Electrical Requirements, the following items:
1. Data/catalog cuts for each product and component specified herein, listing all physical and electrical characteristics and ratings indicating compliance with all listed standards.
  2. Describe system operation, equipment and dimensions and indicate features of each component.
  3. Clearly mark on each data sheet the specific item(s) being submitted and the proposed application.
  4. Shop Drawings to include:
    - a. Plot plans and building floor plans, showing location of and conduit routing to all devices.
    - b. Point-to-Point wiring diagram in block or riser format showing all low-voltage lighting control components, conduit and wire types and sizes with cable legend.
  5. Furnish structural calculations for equipment anchorage as described in Section 26 00 10: Basic Electrical Requirements.
  6. Submit Manufacturer's installation instructions.
  7. Complete bill of materials listing all components.
  8. Warranty, per Section 1.8 located below.

#### 1.5 OPERATION AND MAINTENANCE MANUAL

- A. Supply operation and maintenance manuals in accordance with the requirements of Section 26 00 10: Basic Electrical Requirements to include the following:

1. Operation and maintenance manuals shall include the following:
2. A detailed explanation of the operation of the system.
3. Instructions for routine maintenance.
4. Pictorial parts list and part numbers.
5. Shop drawings to include the following:
  - a. Floor plans showing lighting fixture layout, and layout of all network lighting control devices.
  - b. Show network communication cabling and pre-fabricated lengths.
  - c. Indicate device addresses.
  - d. Riser diagram indicating system backbone and headend connections.
6. Telephone numbers for the authorized parts and service distributors.
7. Final testing report.

#### 1.6 QUALITY ASSURANCE

- A. All materials, equipment and parts comprising the units specified herein shall be new, unused and currently under production.
- B. Only products and applications listed in this Section may be used on the Project unless otherwise submitted.

#### 1.7 PRODUCT DELIVERY, STORAGE AND HANDLING

- A. Delivery: Addressable lighting control components shall not be delivered to the Project site until protected storage space is available. Storage outdoors covered by rainproof material is not acceptable. Equipment damaged during shipment shall be replaced and returned to Manufacturer at no cost to Owner.
- B. Storage: Store in a clean, dry, ventilated space free from temperature extremes. Maintain factory wrapping or provide a heavy canvas/plastic cover to protect units from dirt, water, construction debris and traffic. Provide heat where required to prevent condensation.
- C. Handling: Handle in accordance with Manufacturer's written instructions. Be careful to prevent internal component damage, breakage, denting and scoring. Damaged units shall not be installed. Replace damaged units and return equipment to Manufacturer.

#### 1.8 WARRANTY

- A. Units and components offered under this Section shall be covered by a 5 year parts and labor warranty for malfunctions resulting from defects in materials and workmanship. Warranty shall begin upon acceptance by the Owner.

#### 1.9 SYSTEM START-UP

- A. Upon completion of installation, a factory trained dealer service representative shall perform initial start-up of the dimming system. Sufficient time shall be allowed to properly check the system out and perform required minor adjustments before the Engineer's witnessed test shall begin.

### PART 2 - PRODUCTS

#### 2.1 MANUFACTURERS

- A. Products furnished by the following Manufacturers shall be acceptable if in compliance with all features specified herein and indicated on the Drawings.

1. Network lighting control system:
  - a. SensorSwitch "nLight".
  - b. Wattstopper "Digital Light Management" (DLM).
  - c. Douglas "Dialog Room Controller".
  - d. Eaton/Cooper "Room Controller".

## 2.2 GENERAL

- A. All components of the network lighting control system shall connect via Class 2 low voltage cable; Cat-5 cabling with RJ-45 connectors, or 2-wire non-polarized data line. Cabling color shall be black.

## 2.3 ROOM CONTROLLERS OR NETWORK POWER/RELAY PACKS

- A. Provide universal voltage (120V or 277V), network room controllers or power packs for control of each lighting zone indicated on the plans. Quantity of devices required within each room may vary by manufacturer.
- B. The room controller/power pack shall provide Class 2 power to other devices connected to the system.
- C. Each device shall incorporate one or more Class 1 relays, rated as follows:
  1. 20A Suitable for General Purpose Loads @ 120/277/247VAC
  2. 20A Suitable for Standard Ballasts and Tungsten Loads @ 120/277VAC
  3. 16A Suitable for Electronic Ballasts @ 120/277VAC
  4. 0.5HP @120/277Vac
- D. Provide devices with 0-10V control output for dimming applications.
- E. The device shall mount to an electrical junction box via threaded chase nipple.
- F. Locate room controllers/power packs above accessible ceiling space, preferably in front of doorway. Identify the location of the device with type-on-tape visible from below the ceiling.

## 2.4 WALLBOX DIMMERS AND SWITCHES

- A. Devices shall recess into single-gang switch box and fit a standard GFI opening.
- B. All devices shall provide toggle switch (on/off) control. Dimming control and low temperature/high humidity operation are available options.
- C. Devices with mechanical push-buttons shall provide tactile and LED user feedback.
- D. Devices with mechanical push-buttons shall be made available with custom button labeling

## 2.5 OCCUPANCY SENSOR

- A. General:
  1. Occupancy sensors shall comply with the latest edition of the California Building Energy Efficiency Standards, California Building Code, Part 6 and be certified by The California Energy Commission. All sensors shall be listed in the most current directory of Certified Occupancy Sensing Devices or be on file with the CEC.
  2. Occupancy sensors shall be dual-technology type infrared/ultrasonic.

3. All sensors shall have an adjustable time delay for turning off lights and a sensitivity adjustment.
4. All sensors shall be ceiling mounted and shall operate at low-voltage, maximum 24VDC input, 40mA current draw. Sensors shall be powered via the system.
5. Units shall be furnished to cover the areas being controlled. No allowance shall be given for providing sensors improperly sized for the square footage of the controlled area.

B. Color: Device color shall be white, unless otherwise noted.

C. Ceiling mounted single-directional sensors:

1. Sensor shall have a minimum coverage of up to 900 square feet.
2. Operation shall be automatic "ON" and automatic "OFF".
3. Time delay adjustment from 30 seconds to 30 minutes. Set adjustment at 20 minutes. Set sensitivity adjustment at maximum.
4. For use in small office areas.

D. Ceiling mounted omnidirectional sensors:

1. Sensor shall have a minimum coverage of up to 1000 square feet.
2. Operation shall be automatic "ON" and automatic "OFF".
3. Time delay adjustment from 30 seconds to 15 minutes. Set adjustment at 20 minutes. Set sensitivity adjustment at maximum.
4. For use in larger open office areas.

## 2.6 DAYLIGHT SENSOR

A. Interior day-light harvesting dimming control sensors:

1. Automatically dims 0–10VDC LED dimming drivers.
2. Closed loop control for natural daylight harvesting.
3. The sensor shall continuously monitor the ambient light level.
4. One sensor shall permit different outputs to switch and/or control light levels as ambient light changes. Light levels shall be controlled by 'sensor only' or in combination with a time schedule or with a dimming switch.
5. Sensor shall be capable of setting a maximum light level which cannot be exceeded during Natural Daylight operations.
6. Dimming sinks up to 20mA.
7. Self-calibrating set-points.
8. Digital set-point control.
9. Push-button programmable.
10. Green LED status indicator.
11. 100 hour lamp burn-in timer mode.

## 2.7 INPUT/OUTPUT "I/O" MODULES

A. General:

1. The universal I/O module provides an interface between lighting components such as ballasts, contact closures, occupancy sensors and photocell sensors to the system communication network.
2. The I/O module automatically detects and addresses the type of device to which it is wired and establishes two-way communication between the ECU and itself. Individually addressable, the I/O module enables each lighting component to be independently controlled and configured.

3. When connected to fixture ballast, the I/O module can switch a fixture “on” or “off” via a relay contained in the module as well as deliver a low-voltage dimming signal to any conventional 0-10V dimming ballast.
4. When connected to an occupancy sensor or photocell sensor, the I/O module provides power to operate the device and relays sensor information from the device to the ECU. The I/O module can also be connected to power relays or switch packs to enable switching of larger electrical loads.
5. In the event of a power failure, I/O modules connected to light fixtures shall default to the “on” state at full light output.

B. Specifics:

1. Voltage compatibility: Universal voltage control to 347VAC maximum.
2. Recommended relay rating: 300 watts, 120-347VAC for local switching.
3. Primary relay rating: 6.5A, 120-277V or 4.5A, 347-480V with up to 2 ballasts.
4. Compatibility with electronic dimming ballasts using 0 to 10VDC dimming signals.
5. Power:
  - a. Supplies 12 to 24VDC, 40mA maximum for occupancy sensors.
  - b. Supplies 10VDC, 25mA for photocell sensors.
6. Control signal: Supplies 0-10VDC, 25mA maximum dimming signal to attached ballast or receives control signal from attached sensor.
7. Two RJ45 connectors for communication network connection.
8. Memory: Retains all system settings in non-volatile memory.

C. Mounting:

1. The I/O module is easily mounted to a lighting fixture or electrical junction box knock-out via threaded hub base with lock-nut.
2. Mounts to standard ½” knock-out.

D. Environmental Specifications

1. Operating Temperature Range: 0°C to 40°C
2. Relative Humidity: 20% to 90% non-condensing

2.8 RELAY PANEL

- A. Addressable relay panel that fully integrates with the addressable control system, consisting of individual relays, control module, power supplies, network connection interface, DIN rail supports and cabinet.
- B. Cabinet: NEMA 1 enclosure sized to accept up to 24 relays. Enclosure shall be 19" high x 18" wide x 4" deep minimum.
- C. Cover: Standard surface mount, hinged, lockable cover with windows for viewing relay status indicators. A wiring schedule directory card shall be affixed to the rear of the cover.
- D. Interior: DIN rail supports for relays and circuit board back control module pre-wired to relays. Each relay can be addressed as individual zone or as part of a larger zone and is controlled through the software.
- E. Control relays: Heavy-duty momentary pulsed mechanically latching contactors. Operating voltage is 24VAC; contacts are rated at 20 amps at 120 or 277VAC. They shall attach to the interior DIN rail support and pre-wire to circuit board.



- F. Control module: The control module is mounted in the center of the panel with 12 relays on either side and is wired to each individual relay. Each relay is addressable via the control module can be controlled independently via the system software.
- G. Power supply: 120/277VAC input transformer with 24VAC, 60Hz, 1.6A (40VA) Class II power supplies output.
- H. Network connection: Class 2 wiring input.

## 2.9 EMERGENCY LIGHTING CONTROL

- A. Provide a UL 924 listed device capable of emergency lighting circuit control. The device shall force emergency lights ON upon loss of normal power. Features include:
  - 1. 120/277 volts, 50/60 Hz, 20 amp ballast rating
  - 2. Push to test button
  - 3. Auxiliary contact for remote test or fire alarm system interface

## 2.10 NETWORK COMPONENTS & CABLING

- A. All Ethernet components including IP addressing scheme must be pre-approved by the owner .
- B. Provide control module (Gateway) as required to facilitate communication of network devices, linking into an Ethernet, and linking into the lighting control system management software. This network capability may also be integral to the Room Controller device.
- C. Network cabling shall be Class 2 wiring as recommended by the specified manufacturer.
- D. Provide lighting control cables that are to be different in color than data/voice cables. Contractor shall confirm cable color with owners representative during the submittal process.

## 2.11 SYSTEM SOFTWARE

- A. Every device parameter (e.g. sensor time delay and photocell set-point) shall be available and configurable remotely from the software
- B. The following status monitoring information shall be made available from the software for all devices for which it is applicable: current occupancy status, remaining occupancy time delay(s), current photocell reading, current photocell inhibiting state, photocell transitions time remaining, current dim level, device temperature, and device relay state(s).
- C. The following device identification information shall be made available from the software: model number, model description, serial number, manufacturing date code, custom label(s), and parent network device.
- D. A printable network inventory report shall be available via the software.
- E. A printable report detailing all system profiles shall be available via the software.
- F. Software shall require all users to login with a User Name and Password.
- G. Software shall provide at least three permission levels for users.
- H. All device firmware and system software updates must be available for automatic download and installation via the internet.
- I. Software shall be capable of managing systems interconnected via a WAN (wide area network)

### PART 3 - EXECUTION

#### 3.1 EXAMINATION

- A. Contractor shall thoroughly examine Project site conditions for acceptance of low-voltage lighting control installation to verify conformance with Manufacturer and Specification tolerances. Do not commence with installation until all conditions are made satisfactory.

#### 3.2 INSTALLATION

- A. Install the network lighting control system in accordance with the Manufacturer's written instructions, as indicated on the shop drawings and as specified herein.
- B. All components of the network lighting control system are not necessarily shown on the plans. Provide all components required for a complete and functional system; locate devices not shown on the plans where they can be easily accessed for maintenance, and include location on the record drawings (shop drawings).
- C. Coordinate location of all wall and ceiling mounted devices with the architectural RCPs and elevations.
- D. Locate relay panel(s) where indicated on the plans.
- E. All exterior lighting fixtures shall be controlled via astronomical time clock. On one (1) hour before sun down and off one (1) hour after sun rise.
- F. Route cabling in conduit except above accessible ceiling space. Where cabling is exposed, it shall be white, gray or off-white in color.

#### 3.3 OCCUPANCY SENSOR SWITCHES

- A. Calibrate all sensor time delays and sensitivity to guarantee proper detection of occupants and energy savings.
- B. Coverage of occupancy sensors may vary by manufacturer. It shall be the responsibility of the Contractor to place sensors in the proper place and with proper alignment to cover to all the area intended in the Contract Documents.

#### 3.4 PROGRAMMING

- A. Programming of the addressable lighting control system shall be by a factory-authorized agent of the Manufacturer of the system. All programming, testing, trouble shooting, etc. shall be included in this contract.
- B. Coordinate all Ethernet physical connectivity and IP addressing with the owner in advance of programming and installation.

#### 3.5 FIELD QUALITY CONTROL

- A. Prefunctional testing:
  - 1. Visual and mechanical inspection:
    - a. Inspect for physical damage, defects alignment and fit.
    - b. Perform mechanical operational tests in accordance with Manufacturer's instructions.
    - c. Compare nameplate information and connections to Contract Documents.

- d. Check tightness of all control and power connections.
  - e. Check that all covers, barriers and doors are secure.
2. Contractor shall provide all necessary programming assistance to set up and program the low-voltage lighting control equipment.
3. Electrical tests:
- a. The system shall be completely tested in accordance with operational parameters, tolerances and Manufacturer's instructions. Any problem shall be documented and corrected.
  - b. Test all control circuits and verify proper operation of all lighting circuits throughout the control system.
  - c. Ensure the lighting zone controls match that of the Contract Documents.
  - d. Provide a complete report listing every device, the date it was tested, the results and the date retested (if failure occurred during the previous test). The test report shall indicate that every device tested successfully.
- B. Contractor shall replace all devices which are found defective or do not operate within factory specified tolerances.
- C. Contractor shall submit the testing report for review prior to Project closeout and final acceptance by the Owner. Test report shall indicate test dates, devices tested, results, observation, deficiencies and remedies.
- 3.6 TRAINING
- A. Contractor shall conduct a 2 hour training session for Owner's Representatives upon completion and acceptance of system. Instruction shall include operation, programming and maintenance of equipment.
  - B. Contractor shall schedule training with a minimum of 7 days advanced notice.

**END OF SECTION 26 09 26**

## SECTION 26 24 16 - PANELBOARDS

### PART 1 - GENERAL

#### 1.1 SUMMARY

- A. Work included: Labor, materials and equipment necessary to complete the installation required for the item specified under this Division, including but not limited to:
- B. Related Work: Consult all other Sections, determine the extent and character of related Work and properly coordinate Work specified herein with that specified elsewhere to produce a complete installation.

#### 1.2 REFERENCES

- A. Comply with the latest edition of the following applicable Specifications and standards except as otherwise indicated or specified.
  - 1. Federal Specifications (FS):
    - FS W-C-375; Circuit Breakers, Molded Case, Branch Circuit and Service.
    - FS W-P-115; Power Distribution Panel.
    - FS W-S-865; Enclosed Knife Switch.
  - 2. National Electrical Manufacturers Association (NEMA):
    - NEMA AB 1; Molded Case Circuit Breakers.
    - NEMA KS 1; Enclosed Switches.
    - NEMA PB 1; Panelboards.
    - NEMA PB 1.1; Instructions for safety instruction, operation and maintenance of panelboard rated 600 volts or less.
  - 3. Underwriters Laboratories, Inc. (UL):
    - UL 67; Panelboards.
    - UL 486E; Equipment Wiring Terminals for Use with Aluminum and/or Copper Conductors.
    - UL 489; Molded-Case Circuit Breakers, Molded-Case Switches and Circuit Breaker Enclosures.
    - UL 512; Fuseholders.
    - UL 870; Wireways, Auxiliary Gutters and Associated Fittings.

#### 1.3 SUBMITTALS

- A. Submit in accordance with the requirements of Section 26 00 10: Basic Electrical Requirements, the following items:
  - 1. Data/catalog cuts for each product and component specified herein, listing all physical and electrical characteristics and ratings indicating compliance with all listed standards
  - 2. Clearly mark on each data sheet the specific item(s) being submitted and the proposed application.
  - 3. Shop Drawings: Include elevations, cabinet dimensions, gutter sizes, layout of contactors, relays, time clocks, lug sizes, bussing diagrams; make, location and capacity of installed equipment; mounting style; finish and panelboard nameplate inscription.
  - 4. Furnish structural calculations for equipment anchorage as described in Section 26 00 10: Basic Electrical Requirements.
  - 5. Submit Manufacturer's installation instructions.
  - 6. Complete bill of material listing all components.
  - 7. Warranty.

- B. Dimensions and configurations of panelboards shall conform to the spaces allocated on the Drawings for their installation. The Contractor shall include with the submittal a layout of the electrical room if it differs from construction documents for review and approval by the Engineer prior to release of order.

#### 1.4 OPERATION AND MAINTENANCE MANUAL

- A. Supply operation and maintenance manuals in accordance with the requirements of Section 26 00 10: Basic Electrical Requirements, to include the following:
  1. A detailed explanation of the operation of the system.
  2. Instructions for routine maintenance.
  3. Pictorial parts list and parts number.
  4. Telephone numbers for authorized parts and service distributors.
  5. Final testing reports.

#### 1.5 QUALITY ASSURANCE

- A. All materials, equipment and parts comprising the units specified herein shall be new, unused and currently under production.
- B. Only products and applications listed in this Section may be used on the Project unless otherwise submitted.

#### 1.6 PRODUCT DELIVERY, STORAGE AND HANDLING

- A. Delivery: Panelboard components shall not be delivered to the Project site until protected storage space is available. Storage outdoors covered by rainproof material is not acceptable. Equipment damaged during shipment shall be replaced and returned to Manufacturer at no cost to Owner.
- B. Storage: Store in a clean, dry, ventilated space free from temperature extremes. Maintain factory wrapping or provide a heavy canvas/plastic cover to protect units from dirt, water, construction debris and traffic. Provide heat where required to prevent condensation.
- C. Handling: Handle in accordance with NEMA PB1.1 and Manufacturer's written instructions. Be careful to prevent internal component damage, breakage, denting and scoring. Damaged units shall not be installed. Replace damaged units and return equipment to Manufacturer.

#### 1.7 WARRANTY

- A. Units and components offered under this Section shall be covered by a 1 year parts and labor warranty for malfunctions resulting from defects in materials and workmanship. Warranty shall begin upon acceptance by the Owner.

#### 1.8 EXTRA MATERIAL

- A. Turn over two (2) sets of panelboard keys to the Owner at completion of Project. All panelboards shall be keyed alike.
- B. Provide one spray can of matching finish paint for touching up damaged surfaces after installation.

## PART 2 - PRODUCTS

### 2.1 MANUFACTURERS

- A. Products furnished by the following Manufacturers shall be acceptable if in compliance with all features specified herein and indicated on the Drawings.
1. ABB/ General Electric.
  2. Eaton.
  3. Siemens.
  4. Square D.
  5. Or approved equal.

### 2.2 PANELBOARDS - GENERAL

- A. Enclosure:
1. Cabinets shall be NEMA Type 1 enclosure, door and trim of code gauge galvanized steel. Provide NEMA Type 3R enclosures for exterior mounted panelboard.
  2. Panelboard covers shall be door-in-door construction such that inner door exposes the overcurrent protective devices and the outer door exposes the complete panelboard interior (i.e. branch circuit conductors, lugs, neutral and ground bus, overcurrent protective devices, etc.). Outer door shall have full-length piano hinge and inner door shall have two-point hinges.
  3. Provide combination spring catch and lock on inside edge of the inner door trims with flush fitting joint between door and trim. Locks on all panelboards shall be keyed alike. Doors 36 inches and over in height shall be provided with three-point catch and lock. Provide quarter-turn captive bolts on the outer door.
  4. Bus assembly and terminations:
  5. Bus shall be bolted copper with taps arranged for distributed phase connections to branch circuit devices
  6. Cross connectors shall be copper , drilled and tapped for bolt-on device connections, arranged for double row placement of device and designed to permit removal or addition of overcurrent protection devices without disturbing adjacent devices or removing main bus connections.
  7. Neutral bus shall be 100 percent rated of phase bus bars and shall have lugs for each outgoing branch circuit or feeder requiring a neutral connection unless otherwise noted.
  8. Ground bus shall be full size with lugs for each outgoing branch circuit and feeder.
  9. Refer to panelboard schedules on Drawings for bus rating. Bus rating shall match or be greater than main device or main lug rating.
  10. As a minimum, bus bars shall be rated 22,000 AIC for 120/208 volt panelboards. Unless otherwise noted. Contractor shall field coordinate the available fault current from the utility prior to equipment submittal and confirm minimum AIC values necessary.
  11. Provide full sized bussing in all sections of multi-section panelboards.
  12. No panelboard section shall have greater than 42 poles.
  13. Termination Lugs: Rated for use with aluminum/copper conductors.
  14. All "SPACES" shall be ready for installation of future overcurrent protective device.
- B. Miscellaneous requirements:
1. Circuit numbering: Starting at the top, indicate odd numbered circuits in sequence down the left hand side and even numbered circuits down the right hand side. Multi-section panelboards shall have continuous consecutive circuit numbers, i.e. Section 1 (circuit numbers 1-42), Section 2 (circuit numbers 43-84), Section 3 (circuit numbers 85-126). Provide metal embossed circuit identification of panelboards.
  2. Directories: A 6" x 8" minimum size circuit directory frame and card with clear plastic covering shall be provided inside the inner panelboard door to reflect conditions at

completion of Work. Directory shall be typewritten denoting loads served by room number or area for each circuit.

3. Nameplates: Provide engraved nameplate for each panelboard. See Section 26 05 33: Electrical Identification for requirements.

C. Refer to Panelboard Schedules for the following:

1. Mounting style; service voltage; terminal lug size, location and quantity; bus ampacity; interrupting capacity of bus and breakers; quantity, poles and rating of overcurrent protective devices.

D. Overcurrent protective devices:

1. Refer to Section 26 28 16: Overcurrent Protection Devices.
2. Overcurrent protective devices shall be molded case circuit breakers.
3. Main devices shall be hard bus connected to the panelboard bus bars.
4. In all cases, panelboards fed directly from a transformer shall have a main overcurrent protective device. If not indicated on the Drawings or Panelboard Schedules, provide this device sized to provide the full capacity of the transformer rating.
5. Main devices shall be vertically mounted and shall have their operating handle in the up position when energized. Main devices that are mounted in the same manner as the branch devices are NOT acceptable; i.e. main devices shall be individually mounted at the top or bottom of the phase bus bars.
6. Panelboards overcurrent protective devices layout shall conform to the layout indicated on the panelboard schedules.
7. Provide handle ties for single pole circuit breakers that share a neutral conductor.
8. Where panelboards are existing and have existing breakers, they may be re-used, UON.

- E. Finish: Five step zinc phosphate pre-treatment, one coat of rust inhibiting dichromate primer and one coat of baked-on enamel finish, ANSI 61 (light gray).

## 2.3 BRANCH CIRCUIT PANELBOARDS

- A. Enclosure shall be 20" wide x 5-3/4" deep, surface or flush mounted and shall comply with NEMA PB 1 and FS W-P-115.
- B. Flush panelboards mounted adjacent to each other shall be same physical size.
- C. Where "SPACE" is indicated on panelboard schedules or Drawings, install minimum 100-ampere branch circuit cross connectors and mounting hardware. For future device spaces larger than 100 amps, cross connectors shall match the frame size ampere rated noted.

## PART 3 - EXECUTION

### 3.1 EXAMINATION

- A. Contractor shall thoroughly examine Project site conditions for acceptance of panelboard installation to verify conformance with Manufacturer and Specification tolerances. Do not commence with installation until all conditions are made satisfactory.

### 3.2 INSTALLATION

- A. Install panelboards in accordance with Manufacturer's written instructions, as indicated on the Drawings and as specified herein.

- B. Set panels plumb and symmetrical with building lines in conformance with PB1.1. Furnish and install all construction channel bolts, angles, etc., required to mount the equipment furnished under this Section.
- C. Mounting height shall be 6 feet.
- D. Panelboards shall be anchored and braced to withstand seismic forces as calculated per Section 26 00 10: Basic Electrical Requirements.
- E. Provide mounting hardware brackets, busbar drillings and filler pieces for all unused spaces.
- F. "Train" interior wiring; bundle and clamp, using specified plastic wire wraps specified under Section 26 05 19: Building Wire and Cable.
- G. Replace panel pieces, doors or trim exhibiting dents, bends, warps or poor fit that may impede ready access, security or integrity.
- H. Conduits terminating in concentric, eccentric or oversized knockouts at panelboards shall have ground bushings and bonding jumpers installed interconnecting all such conduits and the panelboard.
- I. Check and tighten all bolts and connections with a torque wrench using Manufacturer's recommended values.
- J. Provide four 3/4" spare conduits stubbed-out of flush mounted panelboards to nearest accessible ceiling space.
- K. Visually inspect panelboard for rust and corrosion. If signs of rust and corrosion are present, restore or replace panelboard to new condition.
- L. In damp and wet locations, mount panelboards with a minimum one inch of air space between cabinet and the wall or other support material.
- M. Provide close up plugs in all unused openings in the cabinet.
- N. Field install handle ties on single pole circuit breakers that share a neutral conductor.
- O. Circuit breakers feeding "Fire Alarm Control Panel(s)" shall be red in color.

### 3.3 FIELD QUALITY CONTROLS

- A. Testing of overcurrent protective devices shall be done only after all devices are installed and system is energized.
- B. Prefunctional testing:
  - 1. Visual and mechanical inspection:
    - a. Inspect for physical damage, defects alignment and fit.
    - b. Perform mechanical operational tests in accordance with Manufacturer's instructions.
    - c. Compare nameplate information and connections to Contract Documents.
    - d. Check tightness of all power connections.
    - e. Check that all covers, barriers and doors are secure.
  - 2. Electrical tests:



- a. Ground resistance: Test resistance to ground of system and equipment ground connection.
    - b. Test overcurrent protection devices per Section 26 28 16: Overcurrent Protective Devices.
  - C. Contractor shall replace all devices which are found defective or do not operate within factory specified tolerances.
  - D. Contractor shall submit the final report for review prior to Project closeout and final acceptance by the Owner. Test report shall indicate test dates, devices tested, results, observation, deficiencies and remedies.
- 3.4 CLEANING
- A. Prior to energizing of panelboards the Contractor shall thoroughly clean the interior of enclosure of all construction debris, scrap wire, etc. using Manufacturer's approved methods and materials.
  - B. Upon completion of Project prior to final acceptance the Contractor shall thoroughly clean both the interior and exterior of panelboards per Manufacturers approved methods and materials. Remove paint splatters and other spots, dirt and debris.
  - C. Touch-up paint any marks, blemishes or other finish damage suffered during installation.

**END OF SECTION 26 24 16**

## SECTION 26 27 26 - WIRING DEVICES

### PART 1 - GENERAL

#### 1.1 SUMMARY

- A. Work included: Labor, materials and equipment necessary to complete the installation required for the item specified under this Division, including but not limited to:
  - 1. Wall switches.
  - 2. Occupancy sensor switches.
  - 3. Receptacles.
  - 4. Coverplates.
- B. Related Work: Consult all other Sections, determine the extent and character of related Work and properly coordinate Work specified herein with that specified elsewhere to produce a complete installation.

#### 1.2 REFERENCES

- A. Comply with the latest edition of the following applicable Specifications and standards except as otherwise indicated or specified.
  - 1. Federal Specification (FS):
    - FS W-P-455A; Plate, Wall Electrical.
    - FS W-C-596; Electrical Power Connector, Plug, Receptacle and Cable Outlet.
    - FS W-S-896; Switch, Toggle.
  - 2. National Electrical Manufacturer's Association (NEMA):
    - NEMA WD-1; General-Purpose Wiring Devices.
    - NEMA WD-5; Specific-Purpose Wiring Devices.
  - 3. Underwriter's Laboratories (UL):
    - UL 20 General-Use Snap Switches.
    - UL 231; Power Outlets.
    - UL 310; Electrical Quick-Connect Terminals.
    - UL 498; Attachment Plugs and Receptacles.
    - UL 514A; Metallic Outlet Boxes.
    - UL 514D; Cover Plates for Flush-Mounted Wiring Devices.
    - UL 943; Ground-Fault Circuit-Interrupters.
    - UL 1681; Wiring Device Configurations.

#### 1.3 SUBMITTALS

- A. Submit in accordance with the requirements of Section 260010: Basic Electrical Requirements, the following items:
  - 1. Data/catalog cuts for each product and component specified herein, listing all physical and electrical characteristics and ratings indicating compliance with all listed standards.
  - 2. Clearly mark on each data sheet the specific item(s) being submitted and the proposed application.
  - 3. Provide color finishes for Architect to select from.
  - 4. Submit Manufacturer's installation instructions.
- B. Where inscribed device coverplates are noted on the Drawings or in the Specifications, conform to the requirements of Section 260553: Electrical Identification.

1.4 QUALITY ASSURANCE

- A. All materials, equipment and parts comprising the units specified herein shall be new, unused and currently under production.
- B. Only products and applications listed in this Section may be used on the Project unless otherwise submitted.

1.5 WARRANTY

- A. Occupancy sensors offered under this Section shall be covered by a five (5) years parts and labor warranty for malfunctions resulting from defects in materials and workmanship. Warranty shall begin upon acceptance by the Owner.

PART 2 - PRODUCTS

2.1 MANUFACTURERS

- A. Products furnished by the following Manufacturers shall be acceptable if in compliance with all features specified herein and indicated on the Drawings.
  - 1. Switches, receptacles and coverplates:
  - 2. Hubbell.
  - 3. Pass & Seymour.
  - 4. Leviton.
  - 5. Occupancy sensors switches:
  - 6. NLight
  - 7. WattStopper
  - 8. Leviton
  - 9. SensorSwitch, Inc.
  - 10. Hubbell Building Automation, Inc.

2.2 WALL SWITCHES

- A. Standards: Provide general-purpose 120/277 VAC switches that conform to NEMA WD-1 Specifications.
- B. Color: Device color shall be white, unless otherwise noted.
- C. Wall switches:
  - 1. Provide twenty ampere, 120/277 volt, Specification grade, designer decora style, quick-make slow-break, quiet type snap switch with silver cadmium alloy contacts, binding head terminal screws, back and side wired with totally enclosed case.
  - 2. Single pole, single throw switches: Hubbell #2121 series, Pass & Seymour #26021 series or Leviton #5621-2 series.
  - 3. Double pole, single throw switches: Hubbell #2122 series, Pass & Seymour #26022 series or Leviton #5622-2 series.
  - 4. Three way switches: Hubbell #2123 series, Pass & Seymour #26023 series or Leviton #5623-2 series.
  - 5. Four way switches: Hubbell #2124 series, Pass & Seymour #26024 series or Leviton #5624-2 series.

2.3 OCCUPANCY SENSOR SWITCHES

- A. General:

1. Occupancy sensors shall comply with the latest edition of the California Building Energy Efficiency Standards, California Building Code, Part 6 and be certified by The California Energy Commission. All sensors shall be listed in the most current directory of Certified Occupancy Sensing Devices or be on file with the CEC.
  2. Occupancy sensors shall be dual-technology type infrared/ultrasonic as specified herein with voltage and wattage rating equal to the lights being controlled.
  3. All sensors shall have an adjustable time delay for turning off lights and a sensitivity adjustment.
  4. Ceiling mounted sensors shall operate on low voltage as supplied by control unit. Control unit shall contain power supply and relays for switching loads.
  5. Units shall be furnished to cover the areas being controlled. No allowance shall be given for providing sensors improperly sized for the square footage of the controlled area.
- B. Color: Device color shall be as selected by Architect, unless otherwise noted.
- C. Wall mounted single level control sensors:
1. Sensor shall be dual-technology infrared/ultrasonic type with single level switching capability and coverage up to 900 square feet.
  2. Operation shall be manual "ON" and manual or automatic "OFF".
  3. Time delay adjustment from 30 seconds to 30 minutes. Set adjustment at 4 minutes.
  4. Load capacity of 0 to 1800 watts at connected voltage.
  5. For use in small utility closets where dual level switching is not indicated.
- D. Wall mounted dual level control sensors:
1. Sensor shall be dual-technology infrared/ultrasonic type with dual level switching capability and coverage up to 1000 square feet.
  2. Operation shall be manual (in two levels) "ON" and manual (in two levels) or automatic (full) "OFF".
  3. Time delay adjustment from 30 seconds to 30 minutes. Set adjustment at 10 minutes. Set sensitivity adjustment at maximum.
  4. Load capacity of 50 to 1000 watts at connected voltages.
  5. Integral photocell, 2 circuit, compatible with electronic bi-level switching ballast. Provide with ambient light control adjustment.
  6. For use in offices where dual level switching is indicated.
- E. Ceiling mounted single-directional sensors:
1. Sensor shall be dual-technology infrared/ultrasonic type single-directional with coverage up to 900 square feet.
  2. Operation shall be automatic "ON" and automatic "OFF". Provide with a manual override switch.
  3. Time delay adjustment from 30 seconds to 30 minutes. Set adjustment at 10 minutes. Set sensitivity adjustment at maximum.
  4. Load capacity of 20 amps per power or slave pack at connected voltage.
  5. Power pack consisting of Class 2, 24V output transformer and relay in single housing, capable of powering up 2 sensors and mounted inside standard 4 inch square box.
  6. For use in small office areas.
- F. Ceiling mounted omnidirectional sensors:
1. Sensor shall be dual-technology infrared/ultrasonic type omnidirectional with coverage up to 1000 square feet.
  2. Operation shall be automatic "ON" and automatic "OFF". Provide with a manual override switch.

3. Time delay adjustment from 30 seconds to 15 minutes. Set adjustment at 10 minutes. Set sensitivity adjustment at maximum.
4. Load capacity of 15 amps per power or slave pack at connected voltage.
5. Power pack consisting of Class 2, 24V output transformer and relay in single housing, capable of powering up to 2 sensors and mounted inside standard 4-inch square box.

## 2.4 RECEPTACLES

### A. Standards:

1. Provide general purpose 20 ampere, 125/250 VAC receptacles that conform to NEMA WD-1 Specifications. Specialty receptacles shall conform to NEMA WD-5 Specifications as applicable.
2. Provide NEMA 5-20R, industrial (heavy-duty) specification grade as noted herein, 20 amp, 125 VAC, 2 pole, 3 wire grounding type receptacles.
3. Receptacles shall be the standard conventional style device.

### B. Color:

1. Device color shall be as selected by the Architect, unless otherwise noted.

### C. General purpose single outlets:

1. Provide self-grounding back and side wired with binding head staked terminal screw.
2. Use Hubbell #5361 series, Pass & Seymour #5361 series Leviton #5361 series.

### D. General purpose duplex receptacles:

1. Provide self-grounding, back and side wired with binding head staked terminal screws and break-off strip for two-circuit wiring.
2. Use Hubbell #5362 series, Pass & Seymour #5362 series or Leviton #5362 series.

### E. Ground fault circuit interrupting (GFCI) receptacles:

1. Provide 20 amp, 125 VAC, receptacles consisting of NEMA 5-20R duplex device with integral solid state sensing and signaling circuitry capable of detecting and interrupting a maximum 5 milli-amp line-to-ground fault current in approximately 1/40th of a second.
2. Provide visual device with trip indication, manual reset and test mechanisms and with point of use and multi-outlet protection.
3. Use Pass & Seymour #2091-S series, Hubbell GF-5362 series, Leviton #6898 series, for Specification grade GFCI receptacles.

### F. Special purpose receptacles: Provide Specification grade devices with the NEMA configuration, voltage and current rating, number of poles and ground provisions as noted on the Drawings.

## 2.5 COVERPLATES

### A. General:

1. Provide all coverplates with rounded edges and corners, smooth and free of grooves, embossing or other embellishment.
2. Provide mounting screws to match the plate finish.
3. Provide gang type coverplates where two or more devices are installed at one location. Individual gangable coverplates are not acceptable.
4. Provide plates of one design, standard conventional or designer decora style, throughout the Project unless otherwise specified.

B. Metal coverplates:

1. Provide smooth, type 430 stainless steel coverplates, 0.035" thick with rounded edges and corners.
2. Provide openings to accommodate the devices indicated on the Drawings and in the Specifications.
3. Provide removable plastic film to protect coverplates during installation. Remove film at time of final acceptance.

C. Weatherproof coverplates:

1. Non-public areas:
  - a. Provide horizontal mounted, weatherproof in-use coverplate for one duplex or one GFCI receptacle. Provide gasketed, spring loaded, vertically self-closing covers suitable for use in damp and wet locations as described in UL 514 and NEC 406. Covers shall allow the use of the device with the cover closed.
  - b. Furnish base plates, covers, hinge pins, spring and screws of corrosion resistant type 302 stainless steel.
2. Public area receptacles:
  - a. Provide horizontal mounted weatherproof in-use coverplate for one duplex or one GFCI receptacle. Provide gasketed, spring loaded, lockable, vertically self-closing covers suitable for use in damp and wet locations as described in UL 514 and NEC 406. Covers shall allow the use of the device with the cover closed.
  - b. Furnish base plates, covers, hinge pins, spring and screws of corrosion resistant type 302 stainless steel.
  - c. Provide two (2) keys for each locking type coverplate.

PART 3 - EXECUTION

3.1 EXAMINATION

- A. Contractor shall thoroughly examine Project site conditions for acceptance of wiring device installation to verify conformance with Manufacturer and Specification tolerances. Do not commence with installation until all conditions are made satisfactory.

3.2 PREPARATION

- A. Coordinate device heights in vending, kitchen and utility areas with benches and counters.
- B. Coordinate switch mounting location with Architectural details. Unless otherwise noted, locate switches on latch side of door.

3.3 INSTALLATION

- A. Install wiring devices in accordance with Manufacturer's written instructions, as indicated on the Drawings and as specified herein.
- B. Install devices with the vertical centerline plumb and with all edges of the device flush against the adjacent wall surfaces.
- C. Mount switches at 42 inches to center above finished floor unless otherwise noted.
- D. Mount receptacles vertically with the centerline 18 inches above finished floor and with grounding slot at bottom.

- E. Mount receptacles vertically when mounting above counters, mount with grounding slot to the left.
- F. Mount GFCI receptacles in the following locations, whether indicated as GFCI type or not on the drawings:
  - 1. In bathrooms.
  - 2. Where receptacles are installed within 6'0" from edge of sinks.
  - 3. In kitchens above counters.
  - 4. On rooftops.
  - 5. Outdoors.
  - 6. Where serving vending machines.
  - 7. Where serving electric drinking fountains.
- G. Provide coverplates for all outlet boxes, switches, receptacles, etc.
- H. Install blank coverplates on all outlet boxes in which no device is required or installed.
- I. Provide coverplates that completely cover wall opening and seat against wall.

### 3.4 OCCUPANCY SENSOR SWITCHES

- A. Set time delays in sensors in accordance with Owner's directions.
- B. Where substituted occupancy sensors are used, it shall be the responsibility of the Contractor to place sensors in the proper place and with proper alignment to cover to all the area intended in the Contract Documents.
- C. Provide one power pack with each ceiling mounted occupancy sensor, whether indicated or not on plans, unless wiring details or plans indicate otherwise.
- D. Where Drawings indicate ceiling mounted slave units, provide 3 #14 in 1/2" conduit from power pack to slave unit and connect so that input from either master or slave sensor will turn lights on.
- E. Install wall mounted devices with the vertical centerline plumb and alleges of device flush against adjacent wall surfaces. Mount devices at 42 inches to center above finished floor unless otherwise noted.

### 3.5 FIELD QUALITY CONTROL

- A. Electrical testing:
  - 1. Test proper polarity of all receptacles.
  - 2. Test ground continuity of all wiring devices.
  - 3. Test ground fault interrupting device operation.
- B. Visual and mechanical inspection:
  - 1. Check proper operation of all switches.
  - 2. Visually inspect and replace damaged or defective devices.

### 3.6 CLEANING

- A. Clean interior of all boxes from dirt and paint prior to installation of devices.
- B. Clean wiring devices and coverplates from dirt and paint over spray.

**END OF SECTION 262726**



## SECTION 26 28 16 - OVERCURRENT PROTECTIVE DEVICES

### PART 1 - GENERAL

#### 1.1 SUMMARY

- A. Work included: Labor, materials and equipment necessary to complete the installation required for the item specified under this Division, including but not limited to:
  - 1. Fuses.
  - 2. Molded case circuit breakers.
- B. Related Work: Consult all other Sections, determine the extent and character of related Work and properly coordinate Work specified herein with that specified elsewhere to produce a complete installation.

#### 1.2 REFERENCES

- A. Comply with the latest edition of the following applicable Specifications and standards except as otherwise indicated or specified:
  - 1. Federal Specification (FS):
    - FS W-C-375; Circuit Breakers, Molded Case, Branch Circuit and Service.
    - FS W-F-870; Fuseholders (for Plug and Enclosed Cartridge Fuses).
  - 2. Underwriters Laboratories, Inc. (UL):
    - UL 248(1-16); Low-Voltage Fuses.
    - UL 489; Molded-Case Circuit Breakers, Molded-Case Switches and Circuit Breaker Enclosures.
  - 3. National Electrical Manufacturer Association (NEMA):
    - NEMA AB 1; Molded Case Circuit Breakers.

#### 1.3 SUBMITTALS

- A. Submit in accordance with the requirements of Section 26 00 10: Basic Electrical Requirements, the following items:
  - 1. Data/catalog cuts for each product and component specified herein, listing all physical and electrical characteristics and ratings indicating compliance with all listed standards.
  - 2. Describe product operation, equipment and dimensions and indicate features of each component.
  - 3. Clearly mark on each data sheet the specific item(s) being submitted and the proposed application.
  - 4. Provide factory certification of trip characteristics for each type and rating of circuit breaker.
  - 5. Provide current let-through and melting time information for each type and rating of fuses.
  - 6. Confirmation in writing of compliance with Arc Energy Reduction per NEC Article 240.87.
  - 7. Submit Manufacturer's installation instructions.
  - 8. Complete bill of material listing all components.
  - 9. Warranty.

#### 1.4 OPERATION AND MAINTENANCE MANUAL

- A. Supply operation and maintenance manuals in accordance with the requirements of Section 26 00 10: Basic Electrical Requirements, to include the following:

1. A detailed explanation of the operation of the system.
2. Instructions for routine maintenance.
3. Parts list and part numbers.
4. Telephone numbers for authorized parts and service distributors.
5. Final testing reports.

#### 1.5 QUALITY ASSURANCE

- A. All materials, equipment and parts comprising the units specified herein shall be new, unused and currently under production.
- B. Only products and applications listed in this Section may be used on the Project unless otherwise submitted.

#### 1.6 PRODUCT DELIVERY, STORAGE AND HANDLING

- A. Delivery: Overcurrent Protective Device components shall not be delivered to the Project site until protected storage space is available. Storage outdoors covered by rainproof material is not acceptable. Equipment damaged during shipment shall be replaced and returned to Manufacturer at no cost to Owner.
- B. Storage: Store in a clean, dry, ventilated space free from temperature extremes. Maintain factory wrapping or provide a heavy canvas/plastic cover to protect units from dirt, water, construction debris and traffic. Provide heat where required to prevent condensation.
- C. Handling: Handle in accordance with Manufacturer's written instructions. Be careful to prevent internal component damage, breakage, denting and scoring. Damaged units shall not be installed. Replace damaged units and return equipment to Manufacturer.

#### 1.7 WARRANTY

- A. Units and components offered under this Section shall be covered by a 1 year parts and labor warranty for malfunctions resulting from defects in materials and workmanship. Warranty shall begin upon acceptance by the Owner.

### PART 2 - PRODUCTS

#### 2.1 MANUFACTURERS

- A. Products furnished by the following Manufacturers shall be acceptable if in compliance with all features specified herein and indicated on the Drawings.
  1. Fuses:
    - a. Bussmann Division, Cooper Industries.
    - b. Gould Shawmut Co.
  2. Circuit breakers:
    - a. ABB/ General Electric.
    - b. Eaton.
    - c. Siemens.
    - d. Square D.

## 2.2 FUSES

- A. General: All power fuses shall be time-delay, high interrupting (300 K AIC), current limiting type, unless otherwise noted on the Drawings. All fuses shall be the product of a single Manufacturer and shall be selectively coordinated when applied in 2:1 ratios. Types of fuses shall be as follows:
  - 1. 0 - 600 amperes: UL Class J, dual element, time delay type fuse with separate overload and short-circuit elements. The fuse shall hold 500% of rated current for a minimum of 10 seconds.
  - 2. Motor branch circuit fuses (0-600 amperes): UL Class J dual element, time delay type fuse. Motor branch circuit fuses shall be sized for Type 2 coordination for the motor controller and back-up motor overload protection and shall be coordinated with motor starter overload relay heaters. See Section 26 29 00: Motor Controls.
- B. Control and instrument fuses shall be suitable for installing in blocks or fuseholders. Exact type and rating shall be as recommended by the Manufacturer of the equipment being protected.
- C. Fuses for installation in current limiting circuit breakers or motor circuit protectors shall meet the specific requirements of the Manufacturers of that equipment to ensure compatibility.

## 2.3 MOLDED CASE CIRCUIT BREAKERS

- A. Branch and feeder circuit breakers shall be molded case, bolt on and trip indicating.
- B. Where stationary molded case circuit breakers are indicated on the Drawings to be current limiting type, they shall be current limiting as defined by UL 489 and shall not employ any fusible elements.
- C. Circuit breakers shall have interrupting capacity not less than that indicated on the Drawings or if not indicated, not less than and 10,000 RMS symmetrical amps for 208 volt systems as coordinated by the contractor with the available fault current.
- D. Covers shall be sealed on non-interchangeable breakers and trip unit covers shall be sealed on interchangeable trip breakers to prevent tampering. Circuit breaker ratings shall be clearly visible after installation or engraved nameplates shall be provided stating the rating. All ferrous parts shall be plated to minimize corrosion.
- E. Circuit breakers shall be toggle, quick-make and quick-break operating mechanisms with trip-free feature to prevent contacts being held closed against overcurrent conditions in the circuit. Trip position of the breakers shall be clearly indicated by operating handles moving to a center position.
- F. Multipole breakers shall have a single handle to open and close all contacts simultaneously in both manual operation and under automatic tripping. Interpole barriers shall be provided inside the breaker to prevent any phase-to-phase flashover. Each pole of the breaker shall have means for Arc extinguishing.
- G. All terminals shall be dual rated for aluminum or copper wire.
- H. Circuit breakers with frame ratings 100 amp and smaller shall be ambient temperature compensated, thermal magnetic type unless otherwise noted. Breakers shall be of full size, 1" per pole type. Panels with more than one branch breaker larger than 100 amps shall be installed in distribution type panels.
- I. Accessories: Provide accessories as noted on the Drawings, i.e. shunt-trip, auxiliary contacts, undervoltage trip, alarm switch, etc.

- J. Spaces in the boards shall be able to accept any combination of 1, 2 or 3 pole circuit breakers as indicated. Provide all necessary bus, device supports and mounting hardware sized for frame, not trip rating.
- K. Series rated breakers are not acceptable unless specifically noted on the Drawings.
- L. Breaker shall be rated to operate in an ambient temperature of 40 degrees C and at 100% of their frame ampere rating on a continuous basis, if indicated on the drawings.

### PART 3 - EXECUTION

#### 3.1 EXAMINATION

- A. Contractor shall thoroughly examine Project site conditions for acceptance of overcurrent protective device installation to verify conformance with Manufacturer and Specification tolerances. Do not commence with installation until all conditions are made satisfactory.

#### 3.2 INSTALLATION

- A. Install overcurrent protective devices in accordance with Manufacturer's written instructions, as indicated on the Drawings and as specified herein.
- B. A fuse identification label shall be placed inside the door of each fused switch. Each label shall show fuse type, ampere rating and Manufacturer.
- C. Tighten electrical connectors and terminals; including screws and bolts, in accordance with equipment Manufacturers published torque-tightening values for equipment connectors. Where Manufacturers torque requirements are not indicated tighten connectors and terminals to comply with tightening torque specified in UL Standard 486A.
- D. Install overcurrent protective devices and accessories in accordance with Manufacturer's written instructions and with recognized industry practices to ensure that protective devices comply with requirements. All devices shall be installed in accordance with applicable NEC and NEMA standards for installation.
- E. Circuit breakers serving "Fire Alarm Control Panel(s)" shall be red in color.

#### 3.3 FIELD QUALITY CONTROL

- A. Testing of overcurrent protective devices shall be done only after all devices are installed and prior to system being energized.
- B. Prefunctional testing:
  - 1. Visual and mechanical inspection:
    - a. Inspect for physical damage, defects alignment and fit.
    - b. Perform mechanical operational tests in accordance with Manufacturer's instructions.
    - c. Compare nameplate information and connections to Contract Documents.
    - d. Check tightness of all control and power connections.
    - e. Check that all covers, barriers and doors are secure.

#### 3.4 ADJUSTING

- A. Adjust circuit breaker trip settings for coordination with other overcurrent protective devices in system.

- B. Adjust circuit breaker trip settings for adequate protection from overcurrent and fault currents.

3.5 CLEANING

- A. Upon completion of Project prior to final acceptance the Contractor shall thoroughly clean overcurrent protective devices per Manufacturer's approved methods and materials. Remove paint splatters and other spots, dirt and debris.

3.6 TRAINING

- A. Factory authorized service representative shall conduct a 1 hour training seminar for Owner's Representatives upon completion and acceptance of system. Instructions shall include safe operation, maintenance and testing of equipment with both classroom training and hands-on instruction.
- B. Contractor shall schedule training with a minimum of 7 days advance notice.

**END OF SECTION 26 28 16**

## SECTION 26 28 19 - DISCONNECT SWITCHES

### PART 1 - GENERAL

#### 1.1 SUMMARY

- A. Work included: Labor, materials and equipment necessary to complete the installation required for the item specified under this Division, including but not limited to:
  - 1. Disconnect Switches.
- B. Related Work: Consult all other Sections, determine the extent and character of related Work and properly coordinate Work specified herein with that specified elsewhere to produce a complete installation.

#### 1.2 REFERENCES

- A. Comply with the latest edition of the following applicable Specifications and standards except as otherwise indicated on specified:
  - 1. Federal Specifications (FS):
    - FS W-F-870; Fuseholders (for plug and enclosed cartridge fuses).
    - FS W-S-865; Switch, Box (enclosed), Surface-Mounted.
  - 2. National Electrical Manufacturer Association (NEMA):
    - NEMA KS 1; Enclosed Switches.
  - 3. Underwriters Laboratories, Inc. (UL):
    - UL 512; Fuseholders.

#### 1.3 SUBMITTALS

- A. Submit in accordance with the requirements of Section 26 00 10: Basic Electrical Requirements, the following items:
  - 1. Data/catalog cuts for each product and component specified herein, listing all physical and electrical characteristics and ratings indicating compliance with all listed standards.
  - 2. As a minimum the following characteristics shall be indicated:
    - a. NEMA types.
    - b. Current rating.
    - c. Number of poles.
    - d. Fuse provisions.
    - e. Enclosure dimensions.
    - f. Voltage.
    - g. Horsepower rating (if applicable).
    - h. Short circuit rating.
  - 3. Clearly mark on each data sheet the specific item(s) being submitted and the proposed application.
  - 4. Submit Manufacturer's installation instructions.

#### 1.4 QUALITY ASSURANCE

- A. All materials, equipment and parts comprising the units specified herein shall be new, unused and currently under production.

- B. Only products and applications listed in this Section may be used on the Project unless otherwise submitted.

## PART 2 - PRODUCTS

### 2.1 MANUFACTURERS

- A. Products furnished by the following Manufacturers shall be acceptable if in compliance with all features specified herein and indicated on the Drawings.
  - 1. ABB/ General Electric.
  - 2. Eaton.
  - 3. Siemens.
  - 4. Square D.

### 2.2 DISCONNECT SWITCHES

- A. Description: Provide NEMA heavy-duty type switches with dead front construction and padlock provisions for up to three locks in the "OFF" position.
- B. Switch interior: Provide switch with switchblades that are fully visible in the "OFF" position when the door is open. Provide UL listed lugs for copper conductors, lugs to be front removable. Provide plated current carrying part.
- C. Switch mechanism: Provide switches with a quick-make, quick-break, position indicating, operating handle and mechanism and a dual cover interlock to prevent unauthorized opening of the switch door in the "ON" position or closing of the switch mechanism with the door open. Furnish an electrical interlock to de-energize control wiring when the disconnect switch is opened.
- D. Enclosures: Provide switches with hinged cover in NEMA 1 general purpose, sheet steel enclosure for dry locations and NEMA 3R weatherproof galvanized enclosures for exterior, damp or wet locations, unless otherwise noted on the Drawings. Provide an enclosure treated with a rust-inhibiting phosphate primer and finished in gray baked enamel.
- E. Ratings: Provide switches that are horsepower rated for 240 VAC or 600 VAC as required for the circuit involved and that meet "I-SQUARED-T" requirements. Fusible switches to have provisions for the types of fuses specified in Section 26 28 16: Overcurrent Protective Devices. UL listed short circuit rating, when equipped with fuses to be 200,000 amperes RMS symmetrical. Furnish with provisions for RK-1 fuses for switches up to 600 amps. 800 amp switches and larger to have provisions for Class L fuses.

## PART 3 - EXECUTION

### 3.1 EXAMINATION

- A. Contractor shall thoroughly examine Project site conditions for acceptance of disconnects switch installation to verify conformance with Manufacturer and Specification tolerances. Do not commence with installation until all conditions are made satisfactory.

### 3.2 PREPARATION

- A. Coordinate locations of switches and equipment in the field to provide code required clearances in front of switches and to ensure that switches are in sight of the controller as described in NEC Article 430.

3.3 INSTALLATION

- A. Install disconnect switches where indicated on the Drawings.
- B. Install fuses in fusible disconnect switches.
- C. Include construction channel and mounting hardware as required to support disconnect switch.

3.4 IDENTIFICATION

- A. Provide engraved, machine screw retained type 'NP' nameplate on each disconnect switch.  
See Section 26 05 53: Electrical Identification.

3.5 CLEANING

- A. Upon completion of Project prior to final acceptance the Contractor shall thoroughly clean both the interior and exterior of enclosure of all construction debris, scrap wire, paint splatters, dirt, etc.

**END OF SECTION 26 28 19**



## SECTION 26 50 00 - LIGHTING

### PART 1 - GENERAL

#### 1.1 SUMMARY

- A. Work included: Labor, materials and equipment necessary to complete the installation required for the item specified under this Division, including but not limited to:
1. Interior luminaires (lighting fixtures.)
  2. Exterior luminaires.
  3. Light-emitting diode (LED) assemblies.
  4. Drivers, ballasts, and transformers.
  5. Optical components; including diffusers, refractors, reflectors, and louvers.
  6. Unit battery equipment.
- B. Related Work: Consult all other Sections, determine the extent and character of related Work and properly coordinate Work specified herein with that specified elsewhere to produce a complete installation.

#### 1.2 REFERENCES

- A. Comply with the latest edition of the following applicable Specifications and Standards except as otherwise indicated or specified:
1. American National Standards Institute (ANSI):
    - ANSI/IEC 60529; American National Standard for Degrees of Protection Provided by Enclosures (IP Code)
    - C136.37; Solid State Light Sources Used in Roadway and Area Lighting.
    - C137.0 Lighting System Terms and Definitions.
    - C137.3; Minimum Requirements for installation of Energy Efficient Power over Ethernet (PoE) Lighting Systems.
  2. Underwriters Laboratories, Inc. (UL):
    - UL 66; Fixture Wire.
    - UL 102.3; Standard Method of Fire Test of Light Diffusers and Lenses.
    - UL 924; Emergency Lighting and Power Equipment.
    - UL924a; Auxiliary Power Supplies (for generator-backed systems.)
    - UL 1598; Luminaires.
    - UL 2108; Low Voltage Lighting Systems.
    - UL 2592; Low Voltage LED Wire.
    - UL 5085-3; Low Voltage Transformers: Class 2.
    - UL 8750; Light Emitting Diode (LED) Equipment for Use in Lighting Products.
    - UL 8754; Holders, Bases, and Connectors for Solid-State (LED) Light Engines and Arrays.
  3. National Electrical Manufacturers Associations (NEMA):
    - SSL-1 Electronic Drivers for LED Devices, Arrays or Systems.
    - SSL-4; Retrofit Lamps—Minimum Performance Requirements.
    - 77; Temporal Light Artifacts: Test Methods and Guidance for Acceptance Criteria.
  4. Illuminating Engineering Society of North America (IESNA):
    - TM-21; Projecting Long Term Lumen Maintenance of LED Light Sources.

TM-30; LM-79;	Method for Evaluating Light Source Color Rendition. Electrical and Photometric Measurements of Solid State Lighting Products.
LM-80;	Measuring Luminous Flux and Color Maintenance of LED Packages, Arrays and Modules.
LM-84;	Measuring Luminous Flux and Color Maintenance of LED Lamps, Light Engines, and Luminaires.
LM-86;	Measuring Luminous Flux and Color Maintenance of Remote Phosphor Components

5. Restriction of Hazardous Substances (RoHS):  
RoHS 3; Directive 2015/863 - Cat 5. Lighting: lamps, lighting fixtures, light bulbs.

### 1.3 SYSTEM DESCRIPTION

- A. Provide and install a fully functional and operating lighting system as indicated, complete with light engines, lamps, wiring, and securely attached to support system to meet all seismic code requirements.
- B. Where catalog number and narrative or pictorial descriptions are provided, the written description shall take precedence and prevail.

### 1.4 SUBMITTALS

- A. Submit in accordance with the requirements of Section 26 00 10: Basic Electrical Requirements, the following items:
  1. Complete bill of material listing (index) of all luminaires. Index shall be organized in the same sequence as the Luminaire Schedule (alphabetical.) Include in the index:
    - a. Type per the Luminaire Schedule.
    - b. Manufacturer.
    - c. Complete catalog number, including all accessories and appurtenances required for the installation.
    - d. Voltage.
  2. Manufacturer's data sheets/catalog cuts for each and every product and component specified herein, listing all physical and electrical characteristics and ratings indicating compliance with all listed standards.
    - e. Identify luminaire type on each sheet.
    - f. Clearly mark on each data sheet the specific item(s) being submitted. Obfuscate or otherwise delete options on data sheets that are not provided.
  3. Driver or transformer, ballast, and/or lamp data sheets as applicable to submitted item.
  4. Manufacturer's installation instructions.
  5. Warranty.
  6. U.L. labeling information.
  7. Suspension details for luminaires recessed in, mounted on or suspended from hung ceilings. Details shall clearly illustrate proposed methods for complying with the requirements of CAC Title 24 and UBC Standard No. 47-18 requiring support independent of the suspended ceiling system.

8. Shop Drawings:

- g. Where noted in the Luminaire Schedule, submit Shop Drawings from Manufacturer detailing modified or custom luminaires indicating dimensions, weights, methods of field assembly, components, features, accessories, methods of support, etc.

1.5 OPERATION AND MAINTENANCE MANUAL

- A. Supply operation and maintenance manuals in accordance with the requirements of Section 26 00 10: Basic Electrical Requirements, to include the following:
  - 1. An updated index per 1.05-A.
  - 2. One complete set of final submittals of actual product installed, including product data and shop drawings.
  - 3. Instructions for routine maintenance.
  - 4. Pictorial parts list and parts number.
  - 5. Telephone numbers for authorized parts and service distributors.

1.6 QUALITY ASSURANCE

- A. All materials, equipment and parts comprising the units specified herein shall be new, unused and currently under production.
- B. Only products and applications listed in this Section may be used on the Project unless otherwise submitted.

1.7 PRODUCT DELIVERY, STORAGE AND HANDLING

- A. Delivery: Luminaires shall not be delivered to the Project site until protected storage space is available. Storage outdoors covered by rainproof material is not acceptable. Equipment damaged during shipment shall be replaced and returned to Manufacturer at no cost to Owner.
- B. Storage: Store in a clean, dry, ventilated space free from temperature extremes. Maintain factory wrapping or provide a heavy canvas/plastic cover to protect units from dirt, water, construction debris and traffic. Provide heat where required to prevent condensation.
- C. Handling: Handle in accordance with Manufacturer's written instructions. Be careful to prevent internal component damage, breakage, denting and scoring. Damaged units shall not be installed. Replace damaged units and return equipment to Manufacturer.

1.8 WARRANTY

- A. Units and components offered under this Section shall be covered by five (5) years parts and labor warranty for malfunctions resulting from defects in materials and workmanship. Warranty shall begin upon acceptance by the Owner.

PART 2 - PRODUCTS

2.1 MANUFACTURERS

- A. Products furnished by the following Manufacturers shall be acceptable if in compliance with all features specified herein and indicated on the Drawings.
  - 1. Luminaires, Poles, and Exit Signs: as listed in the Luminaire Schedule.
  - 2. Light-Emitting Diode (LED) Arrays:
    - a. Cree.

- b. Nichia.
  - c. Citizen.
  - d. Philips Lumileds.
  - e. Samsung.
  - f. Lumenetix Araya.
  - g. Xicato.
  - h. Bridgelux.
  - i. LEDs provided by Luminaire Manufacturer listed in the Luminaire Schedule: meeting the technical and warranty requirements of this Section.
3. LED replacement and integral-driver lamps:
- a. General Electric.
  - b. Osram.
  - c. Cree.
  - d. Maxlite.
  - e. Green Creative.
  - f. Soraa.
4. LED drivers (DC output):
- a. eldoLED.
  - b. Lutron.
  - c. Philips Advance.
  - d. Osram.
  - e. Q-Tran.
  - f. Drivers provided by Luminaire Manufacturer listed in the Luminaire Schedule: meeting the technical and warranty requirements of this Section.
5. Unit battery equipment:
- a. Philips Bodine.
  - b. Iota.
  - c. Unit battery equipment provided by Luminaire Manufacturers listed in the Luminaire Schedule: meeting the technical and warranty requirements of this Section.

## 2.2 GENERAL

- A. Luminaires new and complete with mounting accessories, junction boxes, trims and lamps.
- B. Luminaire assemblies U.L. listed appropriate to mounting conditions and application. All labels affixed to the fixture shall be in a location not visible from normal viewing angles.
- C. Each luminaire family type (downlights, etc.) supplied by only one manufacturer.
- D. Luminaires installed under canopies, roofs or open areas and similar damp or wet locations shall be UL listed and labeled as suitable for damp or wet locations.
- E. Luminaires shall bear the IP rating appropriate for the application.
- F. Luminaires shall be free of light leaks and shall be designed to provide sufficient ventilation of light engines, including ventilation holes where required.

## 2.3 LUMINAIRE CONSTRUCTION

- A. All sheet metal Work shall be free from tool marks and dents and shall have accurate angles bent as sharp as compatible with the gauges of the required metal. 20 gauge (0.7mm or 0.027 inch) minimum.
  - 1. Finish: Baked white dry polyester powder, unless otherwise specified, with a minimum average reflectance of 85% on all exposed and light reflecting surfaces. Steel components shall be prepared for finishing with a 5-step zinc phosphating process prior to painting.
  - 2. Luminaire (including all painted component parts) shall be painted after fabrication unless specifically noted in the Luminaire Schedule.
- B. All surfaces shall be cleaned and dressed to eliminate all exposed sharp edges or burrs.
- C. All intersections and joints shall be formed true and of adequate strength and structural rigidity to prevent any distortion after assembly.
- D. End Plates: Die cast end plates shall be mechanically attached without exposed fasteners. End caps shall be minimum 0.125" thick.
- E. All mitered corners or joints shall be accurately aligned with abutting intersecting members. Sheet metal Work shall be properly fabricated so that planes will not deform (i.e. become concave or convex) due to normal expected ambient and operating conditions.
- F. Ferrous mounting hardware and accessories shall be finished using either a galvanic or phosphate primer/baked enamel process to prevent corrosion and discoloration of adjacent materials.
- G. Fasteners shall be manufactured of galvanized steel.
- H. Adjustable Lamp Mechanisms: To have aiming stops which can be permanently set to position lamp vertically and rotationally.
- I. Recessed luminaires: Equip with through-wire junction box. Box, driver, and replaceable components shall be accessible from the ceiling opening of the luminaire.
- J. Finish:
  - 1. All exposed aluminum surfaces shall be treated with an acid wash and clear water rinse prior to painting. The luminaire shall then be electrostatically painted or powder coated and oven baked in the color indicated in the Luminaire Schedule.
  - 2. All exposed steel surfaces shall be treated with an acid wash and clear water rinse, then prime coated. The luminaire shall then be electrostatically painted or powder coated and oven baked in the color indicated in the Luminaire Schedule.
- K. Door Frames for lensed luminaires: White painted, flat aluminum with mitered corners.

## 2.4 SUSPENSION

- A. Suspension Devices, type as specified in the Luminaire Schedule:
  - 1. Aircraft Cable: Stainless steel type - 3/32" nominal diameter, stranded, with positive pressure, field adjustable clamp at fixture connection.
  - 2. Rigid Pendant: 1/2" nominal diameter or as specifically shown on drawings. Supplied by luminaire manufacturer when available as standard product. At luminaire end of stems,

- provide earthquake type swivel fitting to permit 45° swing in any direction away from vertical.
3. Chain hangers: Length to suit fixture mounting height if shown or as field conditions dictate. Use two heavy duty chains with "S" hooks at each suspension point. Length to suit mounting height as shown on Drawings.
- B. Suspension system must permit  $\pm 13\text{mm}$  (1/2") minimum vertical adjustment after installation.
- C. Supports:
1. Provide internal safety cable from fixture body to stud in outlet box.
  2. Carry fixture weight to structure and provide horizontal bracing from suspension points to ceiling framing to prevent sideways shifting. Provide diagonal seismic restraint wires per code.
- D. Feed Point:
1. Flat-plate canopy to cover outlet box, with holes for support cable and power cord, concealed fasteners to permit splice inspection after installation.
  2. At the electrified connection provide straight cord feed.
  3. Power cord: white multi-conductor cord, parallel to support cable (aircraft cable); within pendant (rigid pendant); or flexible conduit (chain hanger).
- E. Non-feed Points:
1. 13mm (1/2") o.d. polished chrome end sleeve, inside threaded 1/4"-20, with 50mm (2") diameter. Flat white plate to cover hole in ceiling. Top of cable with ball swaged on end, to fit inside sleeve.
  2. Contractor to provide support above ceiling as required.
- F. Suspension method shall allow adjustment to be made in hanging length to allow for variance in ceiling height.
- G. All exposed paintable suspension components shall have the same finish and color as the luminaire housing.

## 2.5 LAMP HOLDERS

- A. Of configuration and design to accept standard lamp bases.
- B. Wiring channels and lampholder mountings shall be rigid and accurately constructed.
- C. Integral-driver LED:
1. Medium screw base: Unglazed porcelain body or thermoplastic (PET GF) with copper-alloy screw shell. 660W, 250V rated.
  2. Bi-Pin base: Ceramic casing with mica cover plate, copper alloy contact surfaces. Pin distance designed for lamp provided.

## 2.6 LED ARRAYS

- A. Minimum lumen maintenance per LM-80 measurements and TM-21 calculations: L90 at 60,000 hours.
- B. Maximum burnout: B90 at 200,000 hours.
- C. Free of mercury and toxic materials; RoHS compliant.

D. Linear LED boards: LED pitch shall be consistent throughout the luminaire and shall remain consistent from the end of one board to the start of the next. LED pitch shall be the same from the endcap of the luminaire to the last LED on the board as the LED pitch throughout the luminaire. Luminaire shall have a continuous luminous appearance – bright or dark spots are not acceptable.

1. TIER 2 (legacy CRI 80)

h. Informational Note: For applications where color fidelity is important, such as offices, schools, general interior areas, etc.

i. Minimum efficacy: 75 lumens per watt.

j. L70 lifetime: minimum 80,000 hours (extrapolated.)

k. Correlated Color Temperature (CCT); as specified in Luminaire Schedule. Maximum 3-step MacAdam ellipse variation throughout listed life (L70).

l. Color Rendering Index (CRI); minimum 80 Ra.

m. R9 value; minimum 30.

n. TM30 values; Rf >80, 85 > Rg > 110.

## 2.7 LED DRIVERS:

A. LED drivers shall be integral to fixture housing or remotely located, when specified, within 15 feet of diode assembly.

1. Luminaires shall be provided with the UL listed or equivalent driver and low voltage power supply as recommended by Manufacturer to insure proper and consistent lamp and luminaire performance. The number of LEDs per luminaire per power supply shall not be exceeded, and LEDs shall not be wired to a high capacity driver unless recommended by Manufacturer.
2. Light Emitting Diode (LED) control gears shall operate with sustained variations of +/- 10% in voltage and frequency without damage to the driver and have a power factor not less than 90%. Regulations: +/- 5% across the listed load range.
3. Driver input current shall have Total Harmonic Distortion (THD) of less than 20%. The Driver shall have a Class A sound rating unless otherwise specified.
4. Control gear shall be rated for 50°C ambient temperature.
5. All control gear shall facilitate smooth dimming from 100% to 1% without flicker.

## 2.8 LENSES

A. Acrylic:

1. Lenses shall be extruded or injection molded crystal clear 100% virgin acrylic (except as indicated otherwise). For lenses with male pattern of pyramids or cones, specified minimum thickness refers to distance from flat surface to base of pyramids (cones) or thickness of undisturbed material. For lenses with female pattern, specified minimum thickness refers to overall thickness of material.
2. Lenses shall fully eliminate lamp images when viewed from all directions within 45 to 90 degree angles from vertical, where the ratio of lamp spacing to the distance from lamp underside to top of lens does not exceed 1.50. Within the viewing angle from 0 to 45 degrees the ratio of maximum brightness (under a lamp) to minimum brightness (between lamps) shall not exceed 3 to 1.

3. Finishes (i.e. sandblasting, etching, polishing) shall be performed as described in the Fixture Schedule.
4. Plastic electrical light diffusers must meet the requirements of Section 2-5209, CAC, Flame Spread Rating.
5. Prismatic Acrylic:
  - a. Extruded of clear virgin acrylic plastic, 0.125" minimum overall thickness, 0.100" nominal unpenetrated thickness, Pattern 12 with flat sided female prisms running at 45 degrees off panel axis unless otherwise specified in the luminaire schedule. Concave prisms are not acceptable.
6. Opal acrylic:
  - a. Extruded or injection molded of virgin acrylic plastic, 0.080" minimum overall thickness.

## 2.9 UNIT BATTERY EQUIPMENT

### A. LED Emergency Power Supplies

1. Standard Features:
2. Safety compliance to UL 924; CAN/CSAC22.2 No.141-10 and NFPA requirements for 90 minute egress
3. Open circuit / short circuit protection
4. Operating temperature: 32F/0C to 122F/50C
5. Test switch / charging indicator light
6. Emergency reaction time < 1 sec
7. Powder coat steel, stainless or galvanized case
8. Field-replaceable NiCd battery pack (x2) with quick connect
9. Min. lead wire length: 6in UL1452 solid/18AWG 1000V/90C

## PART 3 - EXECUTION

### 3.1 EXAMINATION

- A. Contractor shall thoroughly examine Project site conditions for acceptance of luminaire installation to verify conformance with Manufacturer and Specification tolerances. Do not commence with installation until all conditions are made satisfactory.

### 3.2 PREPARATION

- A. Architectural Plans shall govern exact ceiling construction and mounting conditions for all luminaires. Locate as shown on the architectural elevations and reflected ceiling plan.
- B. Consult Architectural Drawings for details of ceiling construction, finish, and other applicable details.
- C. Contractor shall be responsible for coordination of luminaire mounting and compatibility with ceiling construction.
- D. Luminaires in areas where exposed or concealed pipe and ductwork prevents direct access to the structural ceiling shall be provided with appropriate support system to install luminaire below obstructions to avoid conflicts with same.



### 3.3 ARCHITECTURAL COORDINATION

- A. Where luminaires are mounted in architectural coves, soffits, valances or cabinets and are given an overall length, the Contractor shall verify all lengths in the field prior to releasing fixture order.
- B. Where luminaires are surface mounted or suspended to match the length of walls or other architectural elements, the Contractor shall verify all lengths in the field prior to releasing fixture order.
- C. Mounting heights specified on drawings:
  - 1. Wall mounted luminaires: shall be to centerline of luminaire.
  - 2. Pendant mounted luminaires: shall be to bottom of luminaire unless specifically identified in the Luminaire Schedule or on drawings.

### 3.4 INSTALLATION

- A. Install luminaires in accordance with Manufacturer's written instructions, as indicated on the Drawings and as specified herein.
- B. Contractor shall be responsible for all supports, hangers and hardware necessary for a complete installation.
- C. Luminaires shall be plumb, level, square, in straight lines and without distortion.
- D. Remedy light leaks that may develop after installation of recessed or enclosed luminaires.
- E. Adjustable luminaires shall be installed with "dead" zone of rotation away from intended aiming point.

### 3.5 LUMINAIRE SUPPORTS

- A. Physical (gravity) supports:
  - 1. Recessed luminaires in wood framed ceilings shall be supported by 2" x 4" hangers fastened to adjacent ceiling joists.
  - 2. Recessed downlights in wood frame ceilings shall be supported with Manufacturers supplied bar hangers and shall be installed according to the Manufacturers instructions.
  - 3. Surface mounted luminaires solely supported by recessed boxes in a gypsum board ceiling shall have a 1 1/8" steel bar screwed or welded to the back of the box. This steel bar must be long enough to span two ceiling support channels and shall be attached to the channels by twisting wire around the bar and the support channel. For luminaires weighing over 50 pounds, provide fixture studs in recessed box.
  - 4. Support surface mounted luminaires more than 18" wide at or near each corner or edge, in addition to support from outlet box.
  - 5. Support recessed downlights manufactured with built-in brackets by twisting wire around the bracket and two adjacent ceiling support channel runners on either side of the luminaire.
  - 6. Support outlet boxes as specified in Section 26 05 33: Boxes. Provide all boxes with grounding pigtail.
- B. Seismic supports:
  - 1. Recessed luminaires in suspended ceilings shall be supported by connecting two support wires to the luminaire at diagonal opposite corners for luminaires weighing 56 pounds or

- less. Connect four wires, one at each corner for luminaires weighing more than 56 pounds.
2. Surface mounted luminaires on suspended ceilings shall be attached to the main ceiling runner with at least two positive clamping devices and shall have an additional support wire attached to each clamping device and to the structure above.
  3. Recessed downlight luminaires in suspended ceilings shall be supported by connecting one support wire to the luminaire housing.
  4. All suspended luminaires shall be able to swing 45 degrees from vertical in any direction without obstruction.
    - a. Furnish suspended rigid pendant luminaires with universal joint type hanger canopy and longitudinal sway adapter at each stem, to permit 45-degree swivel on 360-degree circle at canopy and 45 degree longitudinal movement at sway adapter.
    - b. Submit Drawings of hanger assembly for review prior to ordering.
    - c. If suspended luminaire is not free to swing 45 degrees in any direction, without obstructions, provide seismic restraint to prevent contact in conformance with California Uniform Building Code, Section 2330, Seismic Design.
  5. All recessed modular luminaires shall be furnished with earthquake clips where installed in tee bar ceiling.

### 3.6 IDENTIFICATION SYSTEM

- A. All concealed junction box cover plates for the lighting branch circuit system shall be clearly marked with a permanent black ink felt pen identifying the branch circuit (both panel designation and circuit number) contained in the box.

### 3.7 FIELD QUALITY CONTROL

- A. Visual and mechanical inspection:
  1. Inspect for physical damage, defects, alignment and fit.
  2. Perform operational test of each luminaire after installed, circuited and energized.
  3. Perform emergency operational test of all luminaires connected to emergency circuiting by simulating normal power source failure.
- B. Contractor shall replace at no cost to the Owner all equipment which is found defective or do not operate within factory specified tolerances.

### 3.8 STOCK

- A. Provide one (1) extra power pack, one F1, F1A, F1B, F1C, F2, F2A and F6 complete LED fixtures, with diffuser/lense.

### 3.9 CLEANING

- A. Clean luminaires prior to Project closeout in accordance with Manufacturer's recommended materials and methods.
- B. Remove all debris, fingerprints, and packaging remnants.

**END OF SECTION 26 50 00**

## SECTION 26 61 13 - FIRE ALARM SYSTEM

### PART 1 - GENERAL

#### 1.1 SUMMARY

- A. Work included: Labor, materials and equipment necessary to complete the installation required for the item specified under this Division, including but not limited to:
1. Fire alarm control panel(s) 'FACP'
  2. Fire alarm annunciators
  3. Initiating devices
  4. Notification appliances
  5. Auxiliary equipment control and supervision
  6. Record Drawings
  7. Pretesting and final testing
- B. Work furnish and installed under another Section, but connected under this Section:
1. Fire sprinkler alarm system flow switches, valve monitors and post indicating valves
  2. Door hold-open/closure devices
  3. Fire/smoke dampers
- C. Work furnished and connected to alarm system under this Section, but installed and connected to HVAC system under another Section:
1. Duct mounted smoke detectors at supply air HVAC equipment 2000 cfm and larger.
  2. In-duct mounted smoke detectors at ducted fire/smoke damper. Except that wiring for damper power, control and monitoring shall be under this contract.
- D. Work furnished and installed under another Section: HVAC shutdown wiring via dry contacts in remote mounted programmable relays.
- E. Related work: Consult all other Sections, determine the extent and character of related Work and properly coordinate Work specified herein with that specified elsewhere to produce a complete installation.

#### 1.2 REFERENCES

- A. Comply with the latest edition of the following applicable Specifications and standards except as otherwise indicated or specified:
1. American National Standards Institute, Inc. (ANSI):  
ANSI C62.41; Guide for Surge Voltage in Low-Voltage AC Power Circuits  
ANSI/ASME A17.1; Safety Code for Elevators and Escalators
  2. National Fire Protection Association (NFPA):  
NFPA 13; Standards for the Installation of Fire Sprinkler Systems  
NFPA 72; National Fire Alarm Code  
NFPA 90A; Standard for the Installation of Air Conditioning and Ventilating Systems  
NFPA 101; Life Safety Code
  3. Underwriters Laboratories, Inc. (UL):  
UL 38; Manually Activated Signaling Boxes  
UL 268; Smoke Detectors for Fire Protective Signaling Systems

UL 268A;	Smoke Detectors for Duct Applications
UL 464;	Audible Signal Appliances
UL 497B;	Protectors for Data Communications and Fire Alarm Circuits
UL 521;	Heat Detectors for Fire Protective Signaling Systems
UL 864;	Control Units for Fire-Protective Signaling Systems
UL 1424;	Cables for Power-Limited Fire-Alarm Circuits
UL 1480;	Speakers for Fire Alarm, Emergency, and Commercial and Professional Use
UL 1481;	Power Supplies for Fire-Protective Signaling Systems
UL 1638	Visual Signaling Appliances Standard
UL 1971	Signal Devices for the Hearing Impaired

4. Factory Mutual System (FM):  
FM P7825 Approval Guide

### 1.3 DEFINITIONS

- A. Addressable device: A fire alarm system initiating, control or monitoring device module component on a signaling line circuit (SLC) with discrete digital identification that can have its status individually identified or that is used to individually control other functions, using site-specific programming at the fire alarm control panel.
- B. Alarm signal: A signal indicating an emergency that requires immediate action, such as a signal indicative of fire.
- C. Annunciator: A unit containing one or more indicator lamps, alphanumeric displays or other equivalent means in which each indication provides status information about a circuit, condition or location.
- D. Circuits and pathways:
1. Class B: Performance that does not include a redundant pathway and will not be capable of operation past a single open or ground fault condition, but does include monitoring and annunciation of a trouble signal when either condition occurs. Any conditions that affect the intended operation of the path are annunciated as a trouble signal.
- E. Initiating device: A system component that originates transmission of a change-of-state condition, such as in a smoke detector, manual fire alarm box or supervisory switch.
- F. Initiating device circuit: A circuit to which automatic or manual initiating devices are connected where the signal received does not identify the individual device operated.
- G. Notification appliances: A fire alarm system component such as a bell, horn, speaker, light or text display that provides audible, tactile or visible outputs or any combination thereof.
- H. Notification appliance circuit: A circuit or path directly connected to a notification appliance(s).
- I. Signaling line circuit: A circuit or path between any combination of circuit interfaces, control units or transmitters over which multiple system input signals or output signals or both, are carried.
- J. Supervisory signal: A signal indicating the need for action in connection with the supervision of guard tours, the fire suppression systems or equipment or the maintenance features of related systems.
- K. Trouble signal: A signal initiated by the fire alarm system or device indicative of a fault in a monitoring circuit or component.

#### 1.4 SYSTEM DESCRIPTION

- A. The fire alarm system shall be a microprocessor-based direct wired, multi-priority, peer-to-peer networked system. The system shall utilize independently addressed, microprocessor-based smoke detectors, heat detectors, and modules as described in this Specification. It shall be complete with all necessary hardware, software and memory specifically tailored for this installation. It shall be possible to permanently modify the software on site by using a plug-in programmer.
- B. It shall be 24Vdc closed circuit, electronically supervised, common signaling, device indicating, and automatic alarm type. The system shall include all wiring, raceways, pullboxes, terminal cabinets, outlet and mounting boxes, control equipment, alarm and supervisory signal initiating devices, alarm notification appliances and all other accessories required for a complete operating system.
- C. Provide system with the following circuit and pathway performance:
1. Initiating devices circuits (IDCs): Class B .
  2. Signaling line circuits (SLCs): Class B .
  3. Notification appliance circuits (NACs): Class B .
- D. Standby power: The standby power supply shall be an electrical battery with capacity to operate the system under maximum supervisory load for twenty four (24) hours and capable of operating the system for five (5) minutes of evacuation alarm on all devices, operating at maximum load. The system shall include a charging circuit to automatically maintain the electrical charge of the battery. The system shall automatically adjust the charging of the battery to compensate for temperature.
- E. Voltage drop:
1. Under all operating conditions, the voltage on the NAC must be sufficient to operate all the notification appliances so that they deliver the proper signal intensity. The worst case operating condition shall be calculated from when the control unit primary power supply has failed and the battery capacity is at its lowest point. An end of useful battery life starting value of 20.4 Volts shall be used at the starting voltage unless the manufacturer's instructions indicate that a higher or lower value should be used. The current draw of an appliance at the minimum listed operating voltage (16 Volts) should be used.
  2. The point-to-point Ohm's Law voltage drop calculations of all alarm system circuits shall not exceed 10%.
- F. Spare capacity: The system shall be engineered to accommodate 20% spare capacity on each individual loop, and 20% spare on system power supplies.
- G. Auxiliary equipment requiring control and monitoring:
1. Flow switches, tamper switches and PIV monitoring
  2. Interface and provide fan shutdown control for all supply fans over 2000cfm
  3. Interface and provide fire/smoke damper (FSD) control and monitoring
  4. Door hold/open release device power and control

#### 1.5 Sequence of operation

- A. General alarm operation: Upon alarm activation of any area smoke detector, duct smoke detector, heat detector, manual pull station, sprinkler waterflow, etc., the following functions shall automatically occur:
1. The internal audible device shall sound at the control panel and annunciator.

2. The LCD Display shall indicate all applicable information associated with the alarm condition including zone, device type, device location and time/date.
  3. Any remote or local annunciator LCD/LED's associated with the alarm zone shall be illuminated.
  4. The following notification signals and actions shall occur simultaneously:
    - a. Horns shall sound throughout the building.
    - b. Activate visual strobes throughout the building.
  5. All self-closing fire/smoke doors held open shall be released.
  6. All automatic events programmed to the alarm point shall be executed and the associated outputs activated.
- B. Supervisory operation: Upon supervisory activation of any sprinkler valve supervisory switch, fire pump off-normal, etc., the following functions shall automatically occur:
1. The internal audible device shall sound at the control panel and annunciator.
  2. The LCD display shall indicate all applicable information associated with the supervisory condition including; zone, device type, device location and time/date.
  3. Any remote or local annunciator LCD/LED's associated with the supervisory zone shall be illuminated.
  4. Transmit signal to the central station with point identification.
- C. Trouble operation: Upon activation of a trouble condition or signal from any device on the system, the following functions shall automatically occur:
1. The internal audible device shall sound at the control panel and annunciator.
  2. The LCD keypad display shall indicate all applicable information associated with the trouble condition including; zone, device type, device location and time/date.
  3. Any remote or local annunciator LCD/LED's associated with the trouble zone shall be illuminated.
  4. Transmit signal to the central station with point identification.
- D. Monitor activation: Upon activation of any device connected to a monitor circuit (fire pump, emergency generator status, etc.), the following functions shall automatically occur:
1. The LCD display shall indicate all applicable information associated with the status condition including; zone, device type, device location and time/date.
  2. Any remote or local annunciator LCD/LED's associated with the status zone shall be illuminated.
- E. In addition to the above sequence of operation, the FACP shall perform the following functions:
1. Identify every addressable device by location, priority and device type.
  2. Read and display at FACP the sensitivity of addressable smoke and heat detection devices.
  3. Remain 100% operational and capable of responding to an alarm condition while in the routine maintenance mode.
  4. Be capable of supporting non-addressable as well as addressable devices.
  5. Allow individual programmable control of each connected remote or panel-mounted relay.
  6. Provide the user with the field programmability to add or change addressable device types and custom messages on-site.
  7. Display up to 127 alarms and/or up to 127 trouble indications, one at a time, as a list on the system printer/terminal.
  8. Change the status of configured circuits (arming or disarming) and change status of relays.

9. Generate an addressable detector sensitivity report providing a chamber voltage listing (device testing) for each detector.

#### 1.6 SUBMITTALS

- A. Submit in accordance with the requirements of Section 260010: Basic Electrical Requirements, the following items:
  1. Data/catalog cuts for each product and component specified herein, listing all physical and electrical characteristics and ratings indicating compliance with all listed standards.
  2. Describe system operation, equipment and dimensions and indicate features of each component.
  3. Clearly mark on each data sheet the specific item(s) being submitted and the proposed application.
  4. Shop Drawings. A complete set of shop drawings shall be supplied. The shop drawings shall be reproduced electronically in digital format. This package shall include but not be limited to:
    - a. All drawings and diagrams shall include the contractor's title block, complete with drawing title, contractor's name, address, date including revisions, and preparer's and reviewer's initials.
    - b. Detailed system operational description. Any Specification differences and deviations shall be clearly noted and marked.
    - c. A riser diagram that individually depicts all control panels, annunciators, addressable devices and notification appliances. Field addressable devices and notification appliances may be grouped together by specific type per loop or circuit.
    - d. Complete 1/8" = 1'-0 scale floor plan drawing locating all system devices and elevation of all equipment. Floor plans shall indicate accurate locations for all control and peripheral devices as well as raceway size and routing, junction boxes, and conductor size, and quantity in each raceway. All notification appliances shall be provided with a candela rating and circuit address that corresponds to that depicted on the Riser Diagram. If individual floors need to be segmented to accommodate the 1/8" scale requirements, KEY PLANS and BREAK-LINES shall be provided on the plans in an orderly and professional manner. End-of-line resistors (and values) shall be depicted.
    - e. Control panel wiring and interconnection schematics. The drawing(s) shall depict internal component placement and all internal and field termination points. Drawing shall provide a detail indicating where conduit penetrations shall be made, so as to avoid conflicts with internally mounted batteries. For each additional data-gathering panel, a separate control panel drawing shall be provided, which clearly indicated the designation, service and location of the control enclosure.
    - f. Complete calculations shall clearly indicate the quantity of devices, the device part numbers, the supervisory current draw, the alarm current draw, totals for all categories, and the calculated battery requirements. Battery calculations shall also reflect all control panel component, remote annunciator, and auxiliary relay current draws.
    - g. System (Load & Battery) calculations shall be provided for each system power supply, each notification appliance circuit and each auxiliary control circuit that draws power from any system power supply.
    - h. Additionally, Drawings shall include:
      - 1) Symbols legend.
      - 2) Equipment list showing quantity, make, model and CSFM listing number for each device.
      - 3) Wire and cable schedule.
      - 4) Scope of Work with overall system description.

- 5) Sequence of operation matrix with system inputs signals and output functions.
  - 6) Code summary and Building type.
  - 7) Assignment of Class and/or Style designation for device circuits.
  - 8) Elevation indicating mounting heights for manual pull stations, audible and visual devices and combination audible/visual devices.
  - 9) Rated penetration details.
  - 10) Typical wiring diagram details of field devices.
  - 11) Detector mounting details at HVAC ducts.
  - 12) Voltage drop calculations for system wiring circuits.
5. Furnish structural calculations for equipment anchorage as described in Section 260010: Basic Electrical Requirements.
  6. Submit Manufacturer's installation instructions.
  7. Complete bill of materials listing all components.
  8. Installer's NICET 3 Certification
  9. Warranty.
- B. Contractor shall submit approved Shop Drawings for review by State or Local Fire Marshal prior to the purchase and installation of equipment. Provide quantities of Drawing sets as required by jurisdiction. Drawings shall be wet stamped and signed by a registered professional Engineer.
- C. Record Drawings:
1. Furnish Record Drawings as described in Section 260010: Basic Electrical Requirements, utilizing Shop-Drawing submissions with updated field conditions. These Drawings shall include but not be limited to the following:
    - a. Plot plans and building floor plans, showing point-to-point wiring location of and conduit routing to all devices.
    - b. Block Diagram/Riser Diagram showing the FACP, system components and all conduit and wire type/sizes between each.
  2. Drawings shall be incorporated into the Record Drawing submission.
  3. Final acceptance will not be made until the Engineer has approved the Record Drawings.

#### 1.7 OPERATION AND MAINTENANCE MANUAL

- A. Supply operation and maintenance manuals in accordance with the requirements of Section 260010: Basic Electrical Requirements, to include the following:
1. A detailed explanation of the operation of the system.
  2. Instructions for routine maintenance.
  3. Pictorial parts list and part numbers.
  4. Schematic Drawings of wiring system, including all initiation and annunciation devices, control panel, annunciators etc.
  5. Telephone numbers for the authorized parts and service distributors.
  6. Final testing reports.

#### 1.8 QUALITY ASSURANCE

- A. All materials, equipment and parts comprising the units specified herein shall be new, unused and currently under production.
- B. Only products and applications listed in this Section may be used on the Project unless otherwise submitted.



1.9 PRODUCT DELIVERY, STORAGE AND HANDLING

- A. Delivery: Fire alarm system components shall not be delivered to the Project site until protected storage space is available. Storage outdoors covered by rainproof material is not acceptable. Equipment damaged during shipment shall be replaced and returned to Manufacturer at no cost to Owner.
- B. Storage: Store in a clean, dry, ventilated space free from temperature extremes. Maintain factory wrapping or provide a heavy canvas/plastic cover to protect units from dirt, water, construction debris and traffic. Provide heat where required to prevent condensation.
- C. Handling: Handle in accordance with Manufacturer's written instructions. Be careful to prevent internal component damage, breakage, denting and scoring. Damaged units shall not be installed. Replace damaged units and return equipment to Manufacturer.

1.10 WARRANTY

- A. Units and components offered under this Section shall be covered by a 1 year parts and labor warranty for malfunctions resulting from defects in materials and workmanship. Warranty shall begin upon acceptance by the Owner.
- B. The warranty package shall include, but not be limited to the following:
  - 1. Emergency maintenance service.
  - 2. Service by factory trained service representative of system Manufacturer.
  - 3. Replacement of any defective components.

1.11 SYSTEM START-UP

- A. Upon completion of installation, a factory trained dealer service representative shall perform initial start-up of the fire alarm system. Sufficient time shall be allowed to properly check the system out and perform required minor adjustments before the Engineer's witnessed test shall begin.

1.12 MAINTENANCE

- A. Maintenance Service:
  - 1. For a period of one year following acceptance the equipment Supplier shall have a person(s) familiar with this Project attend four quarterly meetings with the Owner's Representative to review system performance, operation and any system problems. That person shall provide a written summary of the items discussed in each meeting and a schedule of when the system problems will be corrected. The report is due within 7 working days after each meeting.
  - 2. During the eleventh month following system acceptance, on a weekend day, the equipment Supplier shall perform a complete test of the system, in a manner similar to the acceptance test. A written report shall be submitted to the Owner certifying that each initiating device has been tested. A copy of these test forms shall be submitted to the Engineer for review and acceptance.

PART 2 - PRODUCTS

2.1 MANUFACTURERS

- A. Products furnished by the following Manufacturers shall be acceptable if in compliance with all features specified herein and indicated on the Drawings.

1. EST.
2. Gamewell/FCI (Fire Control Instruments).
3. Notifier.
4. Siemens.
5. Johnson Controls

## 2.2 CONTROL PANEL 'FACP'

### A. General:

1. The control panel shall comply with applicable requirements of UL864 and shall provide power, annunciation, supervision and control for the complete fire alarm system. The panel shall be installed in a flush or surface mounted steel cabinet, containing all modules necessary to operate as indicated herein. The operating controls shall be located behind hinged, locked door with viewing window. All control modules shall be labeled, and all zone locations shall be identified.
2. The panel shall be supervised, site programmable, and of modular design supporting up to 64 network nodes. The peer-to-peer network shall contain multiple nodes consisting of the command center, main controller, remote control panels, and annunciation nodes. Each node is an equal, active functional node of the network, which is capable of making all local decisions and generating network tasks to other nodes in the event of node failure or communications failure between nodes. When utilizing a network and multiple wiring faults occur, the network shall re-configure into many sub-networks and continue to respond to alarm events from every panel that can transmit and receive network messages.
3. The panel module shall control and monitor all local or remote peripherals. It shall support a large 168 character LCD, power supply, remote LCD and zone display annunciators, etc.
4. The programmer shall be able to download all network applications from the configuration computer to all the network panels from a single location on the system.
5. The panels shall have the ability to add an operator interface control/display at each node that shall annunciate, command and control system functions.
6. The system shall store all basic system functionality and job specific data in non-volatile memory. All site specific and operating data shall survive a complete power failure intact.
7. The control panel shall contain a standby power supply that automatically supplies electrical energy to the system upon primary power supply failure. The system shall include a charging circuit to automatically maintain the electrical charge of the battery.
8. All addressable devices shall be individually identified by the system and any quantity of addressable devices may be in alarm at any time up to the total number connected to the system.
9. Dynamic supervision of system electronics, wiring, initiating devices and software shall be provided by the control system. Failure of system hardware or wiring shall be indicated by type and location on the alphanumeric annunciator. Software and processor operation shall be monitored by an independent hardware watchdog, which will indicate their failure. The panel shall provide failsafe operation, i.e. all incoming alarms shall override all other modes of operation.
10. Provide a service mode to permit the arming and disarming of individual initiating or output devices as well as manually operating output devices. Status of these devices shall be displayed upon command from the control panel. The panel shall automatically return to the normal mode in the event the panel remains unattended in the service mode.
11. The panel shall be capable of measuring and adjusting the sensitivity of addressable detectors upon request. An alphanumeric display shall be provided to display custom messages and give readings of detector sensitivity detector by detector. Each device on an addressable initiating circuit shall be checked continuously to include the following:
  - a. Sensitivity.

- b. Response.
  - c. Opens.
  - d. Shorts.
  - e. Ground faults.
  - f. Functionality.
  - g. Status.
12. The panel shall monitor the addressable smoke detectors in such a manner that if the detectors become dirty and reach and maintain 80% of alarm threshold for five (5) consecutive hours, a trouble condition indicating exactly which device needs service shall be automatically annunciated. If the device becomes too insensitive for a period of 10 seconds, the trouble indication will read: "Input device response too low".
  13. The panel shall report, by specific device number, any device removed from an addressable initiating circuit and all other devices shall continue to function.
  14. The panel shall automatically indicate the total quantity of alarms and troubles, which have occurred prior to reset at the control unit.
  15. No alarm or trouble indication shall be resettable until it has been acknowledged. It shall not be possible to reset the system until all alarms have been acknowledged.
  16. The panel shall be capable of:
    - a. Counting the number of addressable devices within a designated area or "zone" which are in alarm.
    - b. Counting "zones" which are in alarm.
    - c. Counting the number of addressable devices, which are in alarm on the system.
    - d. Differentiating among types of addressable devices such as smoke detectors, manual stations, waterflow switches, heat detectors, etc.
    - e. Assigning priorities to types of devices, zones or groups of devices.
    - f. Cross-Zoning.
  17. Each addressable device shall report its condition to the panel control unit every three (3) seconds in a manner such that failure of the connections to or internal electronics of the device will result in a trouble signal that identifies the specific device involved.

B. Signaling line circuits (SLC):

1. The control panel shall be supervised, site programmable, and of modular design supporting up to 125 detectors and 125 remote modules per addressable SLC. The panel shall support up to 10 SLC's per panel for a total system capacity of 2500 intelligent addressable points. The system shall be designed with peer-to-peer networking capability for enhanced survivability, with support for up to 64 nodes, each with up to 2500 points and an overall capacity of 160,000 points.
2. The system shall provide electronic addressing of analog/addressable devices.
3. The system shall have built-in automatic system programming to automatically address and map all system devices attached to the main controller.
4. The system shall use full digital communications to supervise all addressable loop devices for placement, correct location, and operation. It shall allow swapping of "same type" devices without the need of addressing and impose the "location" parameters on replacement device. It shall initiate and maintain a trouble if a device is added to a loop and clear the trouble when the new device is mapped and defined into the system.
5. The system shall have a UL Listed detector sensitivity test feature, which will be a function of the smoke detectors and performed automatically every 4 hours.

C. Digital alarm communicator transmitter (DACT):

1. The system shall provide DACT for off premise communications capability, transmitting system events to single or multiple Central Monitoring Station (CMS) receivers.

2. The system shall be capable of providing the CMS with point identification of system events using Contact ID or SIA DCS protocols.
3. In the event of a panel CPU failure during a fire alarm condition, the DACT degrade mode shall transmit a general fire alarm signal to the CMS.

D. Internal Modular Power Supply:

1. System power supply(s) shall provide multiple power limited 24 VDC output circuits as required by the panel.
2. Upon failure of normal (AC) power, the affected portion(s) of the system shall automatically switch over to secondary power without losing any system functions.
3. Each system power supply shall be individually supervised. Power supply trouble signals shall identify the specific supply and the nature of the trouble condition.
4. All standby batteries shall be continuously monitored by the power supply. Low battery and disconnection of battery power supply conditions shall immediately annunciate as battery trouble and identify the specific power supply affected.
5. All system power supplies shall be capable of recharging up to 260AH batteries, from a fully discharged condition to a capacity sufficient to allow the system to perform consistent with the requirements of this section, in 48 hours maximum.
6. Power supply shall be adequate to supply all system components of the fire alarm system, including FACP modules, initiating devices, notification appliances, remote control and monitoring devices, annunciators, etc. All power connections whether AC or DC shall be separately fused within panel.

E. Storage batteries: Shall be provided and shall be the sealed, lead-acid types. The batteries shall have ample capacity, with primary power disconnected, to operate the fire alarm system for a period of 24 hours. Following this period of operation via batteries, the batteries shall have ample capacity to operate all components of the system, including all alarm annunciating devices in the total alarm mode for a period of 5 minutes. Batteries shall be sized to deliver 50 percent more ampere-hours than required for the calculated capacities. Battery cabinet shall be a separate compartment within the control panel or cabinet.

F. Battery charger: Shall be completely automatic, with high/low charging rate, capable of restoring the batteries from full discharge to full charge within 8 hours. Pilot light shall indicate when batteries are manually placed on a high rate of charge as part of the unit assembly if a high rate switch is provided. Charger shall be located in control panel.

G. Reports:

1. The system shall provide the operator with system reports that give detailed description of the status of system parameters for corrective action, or for preventative maintenance programs. The system shall provide these reports via the main LCD, and shall be capable of being printed on any system printer.
2. The system shall provide a report that gives a sensitivity listing of all detectors that have less than 75% environmental compensation remaining. The system shall provide a report that provides a sensitivity (% Obscuration per foot) listing of any particular detector.
3. The system shall provide a report that gives a listing of the sensitivity of all of the detectors on any given panel in the system, or any given analog/addressable device loop within any given panel.
4. The system shall provide a report to determine the carbon monoxide detectors end-of-life.
5. The system shall provide a report that gives a chronological listing of up to the last 1740 system events.
6. The system shall provide a listing of all of the firmware revision listings for all of the installed network components in the system.

## 2.3 ANNUNCIATORS

### A. Main control and annunciator panel:

1. Main annunciator shall be located with the FACP.
2. The main display shall be a large 168 character LCD with normal, alarm, trouble, supervisory, disabled point and ground fault indicators.
3. The main display shall show the first and most recent highest priority system events without any operator intervention. All system events shall be directed to one of four message queues. Messages of different types shall never inter-mixed to eliminate operator confusion. A "Details" switch shall provide additional information about any device highlighted by the operator.
4. Receipt of alarm, trouble, and supervisory signals shall activate integral audible devices at the control panel(s) and at each remote annunciation device. The integral audible devices shall produce a sound output upon activation of not less than 85 dBA at 10 feet.
5. The internal audible signal shall have different programmable patterns to distinguish between alarm, supervisory, trouble and monitor conditions.
6. The annunciator shall contain the following controls:
  - a. System reset switch with indicator
  - b. System alarm silence switch with indicator
  - c. System panel silence switch with indicator
  - d. Programmable switch with indicator
  - e. Details switch
  - f. System message queue scroll switches.
  - g. 10-Digit keypad to enable/disable system and functions.
7. An authorized operator shall have the ability to operate or modify system functions like system time, date, passwords, holiday dates, restart the system and clear control panel event history file.
8. An authorized operator shall be capable of performing test functions within the installed system.

### B. Fireman's remote annunciator panel (FRAP):

1. Remote LCD network alphanumeric annunciators shall display each and every point in the system.
2. Network alphanumeric annunciators shall be located as indicated on the plans. This annunciator shall be an integral part of the peer to peer network for survivability.
3. Annunciator shall contain a supervised, back-lit, liquid crystal display with a minimum of 8 lines and 21 characters per line. The annunciator shall support full ability to serve as the operating interface to the system and shall include the following features;
  - a. Matched appearance with other system displays
  - b. LCD display shall be configurable to show the status of any or all of the following functions anywhere in the system:
    - 1) Alarm
    - 2) Supervisory
    - 3) Trouble
    - 4) Monitor
4. Annunciator must be capable of supporting custom messages as well as system event annunciation. It must be possible to filter unwanted annunciation of trouble, alarm or supervisory functions on a by point or by geographic area. The annunciators shall be mounted in stand-alone enclosures at location as indicated on the plans.

## 2.4 INTELLIGENT ADDRESSABLE DETECTORS

### A. General:

1. Each detector device shall have a microprocessor with non-volatile memory to support its functionality and serviceability. Devices shall store as required for its functionality the following data: device serial number, device address, device type, personality code, date of manufacture, hours in use, time and date of last alarm, amount of environmental compensation left/used, last maintenance date, job/project number, current detector sensitivity values, diagnostic information (trouble codes) and algorithms required to process sensor data and perform communications with the loop controller.
2. Each device shall be capable of electronic addressing, either automatically or application programmed assigned, to support physical/electrical mapping and supervision by location. Setting a device's address by physical means shall not be necessary.
3. The intelligent detectors shall be capable of full digital communications using both broadcast and polling protocol. Each detector shall be capable of performing independent fire detection algorithms. The fire detection algorithm shall measure sensor signal dimensions, time patterns and combine different fire parameters to increase reliability and distinguish real fire conditions from unwanted deceptive nuisance alarms. Signal patterns that are not typical of fires shall be eliminated by digital filters. Devices not capable of combining different fire parameters or employing digital filters shall not be acceptable.
4. Each detector shall be capable of making alarm decisions based on fire parameter information stored in the detector head. Distributed intelligence shall improve response time by decreasing the data flow between detector and analog loop controller. Maximum total analog loop response time for detectors changing state shall be 0.75 seconds. The integral microprocessor shall dynamically examine values from the sensor and initiate an alarm based on the analysis of data.
5. The detector shall continually monitor any changes in sensitivity due to the environmental effects of dirt, smoke, temperature, aging and humidity.
6. Each detector shall have a separate means of displaying communication and alarm status. A green/red LED shall flash to confirm communication with the analog loop controller and display alarm status.
7. The detector shall be capable of identifying up to 32 diagnostic codes. This information shall be available for system maintenance. The diagnostic code shall be stored at the detector.
8. Each smoke detector shall be capable of transmitting pre-alarm and alarm signals in addition to the normal, trouble and need cleaning information. It shall be possible to program control panel activity to each level. Each smoke detector may be individually programmed to operate at any one of five (5) sensitivity settings.
9. Each device microprocessor shall contain an environmental compensation algorithm, which identifies and sets ambient "Environmental Thresholds" approximately six times an hour. The microprocessor shall continually monitor the environmental impact of temperature, humidity, other contaminants as well as detector aging. The process shall employ digital compensation to adapt the detector to both 24 hour long-term and 4 hour short-term environmental changes. The microprocessor shall monitor the environmental compensation value and alert the system operator when the detector approaches 80% and 100% of the allowable environmental compensation value. Differential sensing algorithms shall maintain a constant differential between selected detector sensitivity and the "learned" base line sensitivity. The base line sensitivity information shall be updated and permanently stored at the detector approximately once every hour.

### B. Ionization smoke detector:

1. The intelligent ionization detector shall be rated for ceiling installation at a minimum of 30 ft centers and be suitable for wall mount applications.

2. The percent smoke obscuration per foot alarm set point shall be field selectable to any of five sensitivity settings ranging from 0.61% to 1.91%. The ionization detector shall be suitable for operation in the following environment:
    - a. Temperature: 32°F to 120°F (0°C to 49°C)
    - b. Humidity: 0-93% RH, non-condensing
    - c. Installation attitude: 6000 feet
    - d. Air velocity: 0 to 75 ft/min
- C. Photoelectric smoke detector:
1. Provide intelligent analog photoelectric detector shall utilize a light scattering type photoelectric smoke sensor to sense changes in air samples from its surroundings.
  2. Each unit shall have a field-replaceable smoke chamber.
  3. The photo detector shall be rated for ceiling installation at a minimum of 30 ft centers and be suitable for wall mount applications.
  4. The photoelectric smoke detector shall be suitable for direct insertion into air ducts up to 3 ft high and 3 ft wide with air velocities up to 5,000 ft/minute.
  5. The percent smoke obscuration per foot alarm set point shall be field selectable to any of five sensitivity settings ranging from 1.0% to 3.5%. The photoelectric detector shall be suitable for operation in the following environment:
    - a. Temperature: 32°F to 120°F (0°C to 49°C)
    - b. Humidity: 0-93% RH, non-condensing
    - c. Installation attitude: no limit
- D. Fixed temperature/rate-of-rise heat detector:
1. Provide intelligent combination fixed temperature/rate-of-rise heat detectors with low mass thermistor heat sensor and operate at a fixed temperature and at a temperature rate-of-rise. It shall continually monitor the temperature of the air in its surroundings to minimize thermal lag to the time required to process an alarm.
  2. The integral microprocessor shall determine if an alarm condition exists and initiate an alarm based on the analysis of the data.
  3. The intelligent heat detector shall have a nominal fixed temperature alarm point rating of 135°F (57°C) and a rate-of-rise alarm point of 15°F (9°C) per minute.
  4. The heat detector shall be rated for ceiling installation at a minimum of 50 ft centers and be suitable for wall mount applications.
- E. Multi-sensor photoelectric/heat detector:
1. Provide intelligent combination photoelectric smoke and heat detectors with analog photoelectric detector that utilizes a light scattering type photoelectric smoke sensor to sense changes in air samples from its surroundings. The heat detector shall have a low mass thermistor heat sensor and operate at a fixed temperature. It shall continually monitor the temperature of the air to process an alarm.
  2. Each unit shall have a field-replaceable smoke chamber
  3. Each unit shall provide split sensor programming such that the combination device shall only require one software address, while still providing two distinct inputs. This capability will allow for separate actions to be initiated independently from the two separate elements (smoke & heat) without requiring a separate software address on the loop.
  4. The multi-sensor shall be rated for ceiling installation at a minimum of 30 ft centers and be suitable for wall mount applications.
  5. The intelligent heat detector shall have a nominal fixed temperature alarm point rating of 135°F (57°C) and a rate-of-rise alarm point of 15°F (9°C) per minute.

6. The percent smoke obscuration per foot alarm set point shall be field selectable to any of five sensitivity settings ranging from 1.0% to 3.5%. The photoelectric detector shall be suitable for operation in the following environment:

- a. Temperature: 32°F to 120°F (0°C to 49°C)
- b. Humidity: 0-93% RH, non-condensing
- c. Installation Attitude: no limit

F. Standard detector bases:

1. Provide standard detector mounting bases suitable for mounting on a standard 4" octagon or square box. The base shall contain no electronics and support all intelligent detector types.
2. Removal of the respective detector shall not affect communications with other detectors.
3. Terminal connections shall be made on the room side of the base.

G. Relay detector bases:

1. Provide standard detector mounting bases suitable for mounting on a standard 4" octagon or square box. The base shall support all intelligent detector types.
2. Removal of the respective detector shall not affect communications with other detectors.
3. Terminal connections shall be made on the room side of the base. Bases, which must be removed to gain access to the terminals, shall not be acceptable.
4. The relay shall be a bi-stable type and selectable for normally open or normally closed operation.
5. The position of the contact shall be supervised.
6. The relay shall automatically de-energize when a detector is removed.
7. The operation of the relay base shall be controlled by its respective detector processor. Detectors operating standalone mode shall operate the relay upon changing to alarm state. Relay bases not controlled by the detector microprocessor shall not be acceptable.
8. Form "C" relay contacts shall have a minimum rating of 1 amp @ 30 Vdc and be listed for pilot duty.

H. Duct detector:

1. Provide intelligent addressable analog photoelectric duct smoke detectors that utilize a light scattering type photoelectric smoke sensor to sense changes in air samples from its surroundings. The integral microprocessor shall dynamically examine values from the sensor and initiate an alarm based on the analysis of data. Systems using central intelligence for alarm decisions shall not be acceptable. The detector shall continually monitor any changes in sensitivity due to the environmental effects of dirt, smoke, temperature, aging and humidity.
2. The percent smoke obscuration per foot alarm set point shall be field selectable to any of five sensitivity settings ranging from 0.79% to 2.46%. The duct detector shall be suitable for operation in the following environment:
  - a. Temperature: -20°F to 158°F (-29°C to 70°C)
  - b. Humidity: 0-93% RH, non-condensing
  - c. Air velocity: 100 to 4000 ft/min
3. Provide an air exhaust tube and an air sampling inlet tube, which extends into the duct air stream up to ten feet. The sampling tube can be installed with or without the cover in place and can be rotated in 45 degree increments to ensure proper alignment with the duct airflow.
4. Status LEDs shall remain visible through a clear assembly cover.
5. The unit shall contain a magnet-activated test switch.



6. One integral Form C auxiliary alarm relay shall be provided. The relay contact shall be capable of being individually programmed from the control panel. The contact shall be rated for 2.0A at 30VDC.

## 2.5 INTELLIGENT ADDRESSABLE MODULES

### A. General:

1. Each remote device shall have a microprocessor with non-volatile memory to support its functionality and serviceability. Devices shall store as required for its functionality the following data: device serial number, device address, device type, personality code, date of manufacture, hours in use, time and date of last alarm, amount of environmental compensation left/used, last maintenance date, job/project number, current detector sensitivity values, diagnostic information (trouble codes) and algorithms required to process sensor data and perform communications with the loop controller.
2. Each device shall be capable of electronic addressing, either automatically or application programmed assigned, to support physical/electrical mapping and supervision by location.
3. The module shall be suitable for operation in the following environment:
  - a. Temperature: 32°F to 120°F (0°C to 49°C)
  - b. Humidity: 0-93% RH, non condensing

### B. Single input module:

1. Provide intelligent signal input modules for monitoring of PIV's, tamper switches, flow switches or any other sets of dry contacts required to be monitored.
2. The single input module shall provide one (1) supervised Class B input circuit capable of a minimum of 4 personalities, each with a distinct operation.
3. The module shall be suitable for mounting on a standard 4" square box with 1-gang ring.
4. The single input module shall support the following circuit types:
  - a. Normally-Open Alarm Latching (Manual Stations, Heat Detectors, etc.)
  - b. Normally-Open Alarm Delayed Latching (Waterflow Switches)
  - c. Normally-Open Active Non-Latching (Monitor, Fans, Dampers, Doors, etc.)
  - d. Normally-Open Active Latching (Supervisory, Tamper Switches)

### C. Dual input module:

1. Provide intelligent dual input modules for monitoring of sets of PIV's, tamper switches, flow switches or any other sets of dry contacts required to be monitored.
2. The dual input module shall provide two (2) supervised Class B input circuits each capable of a minimum of 4 personalities, each with a distinct operation.
3. The module shall be suitable for mounting on a standard 4" square box with 1-gang ring.
4. The dual input module shall support the following circuit types:
  - a. Normally-open alarm latching
  - b. Normally-open alarm delayed latching
  - c. Normally-open active non-latching
  - d. Normally-open active latching

### D. Signal module:

1. Provide intelligent single input signal modules for activation of booster power supplies, audible/visual circuits.
2. The single input signal module shall provide one (1) supervised Class B output circuit capable of a minimum of 2 personalities, each with a distinct operation.

3. The module shall be suitable for mounting on a standard 4" square box with 2-gang ring.
4. The single input signal module shall support audible/visible signal power selector (polarized 24 Vdc @ 2A, 25Vrms @50w or 70 Vrms @ 35 watts of audio)

E. Synchronized signal module:

1. Provide intelligent single input signal modules for activation of booster power supplies and/or audible/visual circuits that require synchronization.
2. The single input signal module shall provide one (1) supervised Class B output circuit capable of a minimum of 2 personalities, each with a distinct operation.
3. The module shall be suitable for mounting on a standard 4" square box with 2-gang ring.
4. The single input signal module shall support audible/visible signal power selector (polarized 24 Vdc @ 2A, 25Vrms @50w or 70 Vrms @ 35 watts of audio)
5. Provides UL1971 auto-sync output for synchronizing multiple notification appliance circuits

F. Control relay module:

1. Provide intelligent control relay modules for activation and/or shutdown of fans, dampers, door holder circuits, door locks, shunt trip, elevator recall or any other fail safe system requiring control or activation.
2. The control relay module shall provide one Form R dry relay contact rated at 2 amps @ 24 Vdc to control external appliances or equipment shutdown.
3. The control relay shall be rated for pilot duty and releasing systems.
4. The control relay module shall be suitable for mounting on a standard 4" square box with 1-gang ring.

G. Manual pull station:

1. Provide intelligent single action, single stage fire alarm pull stations. The fire alarm pull station shall be of metal construction with an internal toggle switch. Provide a locked test feature. Finish the station in red with silver "PULL IN CASE OF FIRE" lettering.
2. The manual station shall be suitable for mounting on a standard 4" square box with 1-gang ring.
3. Provide compatible surface mount red box at all surface mount locations.

## 2.6 NOTIFICATION APPLIANCES

A. Horns:

1. Horns shall be a low profile design, finished in red with white lettering and shall not protrude more than 1" off the finished wall surface. In-out screw terminals shall be provided for wiring.
2. Horns shall be provided with a switch selectable audible output of at least two decibel levels. Maximum 84dBA output at 10 ft. when measured in reverberation room per UL 464.
3. Horns shall have two selectable tone options of temporal or non-temporal continuous pattern.
4. Horns shall be suitable for wall mounting and shall mount in a standard 4" square x 2 1/8" deep electrical box. All mounting hardware shall be captive and there shall be no mounting screws visible after the device is installed.
5. Where surface mounted horns are installed a skirt enclosure or manufacturer's color-matched surface mount box, shall be installed to conceal the electrical box to which the strobe lights are mounted. The correct surface box shall be used to ensure the skirt fits properly and is flush with the wall or ceiling.

B. Strobe lights:

1. Strobes shall be a low profile design, finished in white with red lettering and shall not protrude more than 1" off the finished wall surface. In-out screw terminals shall be provided for wiring.
2. Strobes shall provide synchronized flash outputs at maximum pulse duration of 0.2 seconds. The light output shall be an even pattern with no hot spots. Strobes appliances shall be comprised of a Xenon flashtube with a clear lens and be entirely solid state.
3. The strobe shall have selectable 15, 30, 75 or 110 cd settings for wall or standard ceiling height mounting.
4. The strobe shall have selectable 95, 115, 150 or 177 cd settings for high ceilings.
5. It shall be possible to change the strobe setting without removing the device from the wall or ceiling.
6. Strobes shall be suitable for wall mounting and shall mount in a standard 4" square x 1 1/2" deep electrical box. All mounting hardware shall be captive and there shall be no mounting screws visible after the device is installed.
7. Strobes shall also be suitable for ceiling mounting and shall mount in a standard 4" square x 1 1/2" deep electrical box. All mounting hardware shall be captive and there shall be no mounting screws visible after the device is installed.
8. Where surface mounted strobe lights are installed a skirt enclosure or manufacturer's color-matched surface mount box, shall be installed to conceal the electrical box to which the strobe lights are mounted. The correct surface box shall be used to ensure the skirt fits properly and is flush with the wall or ceiling.

C. Combination horn/strobe lights:

1. Horns shall be a low profile design, finished in red with white lettering and shall not protrude more than 1" off the finished wall surface. In-out screw terminals shall be provided for wiring.
2. Horns shall be provided with a switch selectable audible output of at least two decibel levels.
3. Horns shall have two selectable tone options of temporal or non-temporal continuous pattern.
4. Strobes shall provide synchronized flash outputs at maximum pulse duration of 0.2 seconds. The light output shall be an even pattern with no hot spots. Strobes appliances shall be comprised of a Xenon flashtube with a clear lens and be entirely solid state.
5. It shall be possible to flash the strobe at a temporal flash rate to match the horn.
6. The strobe shall have selectable 15, 30, 75 or 110 cd settings for wall or standard ceiling height mounting.
7. The strobe shall have selectable 95, 115, 150 or 177 cd settings for high ceilings.
8. It shall be possible to change the strobe setting without removing the device from the wall or ceiling.
9. Horn/strobes shall be suitable for wall mounting and shall mount in a standard 4" square x 1 1/2" deep electrical box. All mounting hardware shall be captive and there shall be no mounting screws visible after the device is installed.
10. Horn/strobes shall also be suitable for ceiling mounting and shall mount in a standard 4" square x 1 1/2" deep electrical box. All mounting hardware shall be captive and there shall be no mounting screws visible after the device is installed.
11. Where surface mounted horn/strobe lights are installed a skirt enclosure or manufacturer's color-matched surface mount box, shall be installed to conceal the electrical box to which the strobe lights are mounted. The correct surface box shall be used to ensure the skirt fits properly and is flush with the wall or ceiling.

D. Weatherproof horns and strobes and/or combination appliances:

1. Appliances shall be a semi-flush design, finished in red with white lettering. In-out screw terminals shall be provided for wiring.
2. Horns shall be provided with a switch selectable audible output of at least three decibel levels of 99, 95, and 90dBA.

3. Horns shall have two selectable tone options of temporal or non-temporal continuous pattern.
4. Strobes shall provide synchronized flash outputs at maximum pulse duration of 0.2 seconds. The light output shall be an even pattern with no hot spots. Strobes appliances shall be comprised of a Xenon flashtube with a clear lens and be entirely solid state.
5. The strobe shall have a 75 cd setting for wall or standard ceiling height mounting.
6. Strobe shall operate over an extended temperature range of -31°F to 150°F. All inputs shall be polarized for compatibility with standard reverse polarity supervision of circuit wiring.
7. Appliance backbox shall be weatherproof and vandal resistant.

E. Vibrating bell:

1. Provide 10" surface weatherproof vibrating bell.
2. The bell shall be 24Vdc.
3. Bell shall have heavy-duty cast housing with Red finish.
4. Weatherproof boxes shall be provided for outdoor mounting.

F. Remote booster power supplies:

1. Unit shall be a self contained with 24Vdc power supply and batteries housed in its own locked enclosure. Keys provided shall be identical to the keys provided for all other fire alarm equipment provided.
2. Power supply shall be available in both 10 Amp or 6.5 Amp models and 120Vac.
3. On board LED indicators for each NAC, battery supervision, ground fault and AC power.
4. The power supply shall provide four (4) independent 3Amp NACs. Each circuit can be configurable as an auxiliary output.
5. Configurable for any one of three signaling rates: 120SPM; 3-3-3 temporal; or, continuous.
6. Two independent and configurable inputs switch selectable to allow correlation of the two (2) inputs and the four (4) outputs.
7. NACs shall be configurable for either four Class B or two Class A circuits.
8. The unit shall be compatible with SIGA-CC1S for synchronization of multiple power supplies without inter-connect wiring.
9. Brackets shall be provided inside the enclosure to allow mounting the signaling modules. All signaling modules shall be listed to be located inside the booster power supply enclosure.
10. A selectable dip switch shall enable built in synchronization for horns and strobes which may be used to synchronize downstream devices, as well as other boosters and their connected devices.

2.7 AUXILIARY EQUIPMENT CONTROL AND SUPERVISION

- A. Fire sprinkler system components: Include single or dual input modules at waterflow and/or tamper switch on each floor of building, fire pump room, etc., for monitoring status.
- B. Supply fan/air handlers shutdown: All supply air fan, 2000cfm and greater, shall be furnished with a duct-mounted smoke detector and addressable control relay for shutdown purposes. Upon smoke detection, the fan shall be automatically controlled to the "OFF" position.

PART 3 - EXECUTION

3.1 EXAMINATION

- A. Contractor shall thoroughly examine Project site conditions for acceptance of fire alarm system installation to verify conformance with Manufacturer and Specification tolerances. Do not commence with installation until all conditions are made satisfactory.

### 3.2 INSTALLATION

#### A. General:

1. Install fire alarm system in accordance with Manufacturer's written instructions, as indicated on the Drawings and as specified herein.
2. The 120volt, 2-wire, 60 cycles AC two-20A circuit supply required to power the system shall be connected as indicated on the Drawings. Connect to red colored circuit breaker(s) in panelboard. Identify circuit as "Fire Alarm Circuit Control."

#### B. Conductors:

1. Refer to Section 260519: Building Wire and Cable.
2. All circuits shall be rated power limited in accordance with CEC Article 760.
3. All system conductors shall be of the type(s) specified herein.
  - a. All initiating circuit, signaling line circuit, AC power conductors, shield drain conductors and grounding conductors, shall be solid copper, stranded or bunch tinned (bonded) stranded copper.
  - b. All wiring shall be color-coded throughout.
  - c. Signaling line circuits: Shall be 18 AWG minimum multi-conductor jacketed twisted cable or as per manufacturer's requirements.
  - d. Initiating device circuits: 24Vdc circuits shall be 18 AWG minimum or per manufacturer's requirements.
  - e. Notification appliance circuits:
    - 1) Horn-strobe or strobe: Non-twisted pair, not less than 14 AWG or as recommended by the manufacturer.
  - f. 120Vac circuits:
    - 1) Minimum 10 AWG for panel power circuits.
    - 2) Minimum 12 AWG for all other circuits.
    - 3) Each circuit shall have its own dedicated neutral conductor.

#### C. Conduit raceway:

1. All system components listed to UL864 Control Units for Fire Protective Signaling Systems maybe installed within a common conduit raceway system, in accordance with the manufacture's recommendations. System components not listed to the UL864 standard shall utilize a separate conduit raceway system for each of the sub-systems.
2. All system conduits shall be EMT, 1/2 -inch minimum, except for flexible metallic conduit used for whips to devices only, maximum length 6 feet, 1/2-inch diameter, minimum.
3. Conduits shall be sized according to the conductors contained therein. Cross sectional area percentage fill for system conduits shall not exceed 40%.
4. All fire alarm conduit systems shall be routed and installed to minimize the potential for physical, mechanical or by fire damage, and so as not to interfere with other building systems, facilities or equipment, and to facilitate service and minimize maintenance.
5. All system conduits, junction boxes, pull boxes, terminal cabinets, electrical enclosures and device back boxes shall be readily accessible for inspection, testing, service and maintenance.
6. All penetration of floor slabs and firewalls shall be sleeved (1" conduit minimum) fire stopped in accordance with all local fire codes.
7. All junction box covers shall be painted red.

#### D. Equipment:

1. All devices and appliances shall be mounted to flush mounted boxes where areas are finished. Exceptions being above suspended ceiling, exposed ceiling areas, or equipment rooms to facilitate connections to other equipment.
2. All pull stations shall be mounted 48 inches above the finished floor, as measured on handle.
3. All audio/visual devices shall be mounted at a minimum of 80 inches and no more than 96 inches above the finished floor, as measured on strobe center. Devices shall be mounted no less than 6 inches from the ceiling.
4. No area smoke detectors shall be mounted within 36 inches of any HVAC supply, return air register or lighting fixture.
5. No area smoke or heat detector shall be mounted within 12 inches of any wall.
6. All fire alarm devices shall be accessible for periodic maintenance.
7. End-of-line resistors shall be furnished as required for mounting as directed by the manufacturer. Devices containing end-of-line resistors shall be appropriately labeled. Devices should be labeled so removal of the device is not required to identify the EOL device.
8. All addressable modules shall be mounted within 36 inches of the monitored or controlled point of termination. This shall include, but is not necessarily limited to, fan shutdown, shunt trip, sprinkler status points, or door release. Label all addressable modules as to their function.
9. Power-limited/non-power-limited CEC wiring standards shall be observed.
10. Relays shall be appropriately labeled on the exterior to indicate "FIRE ALARM SYSTEM" and their specific function (i.e. FAN SHUTDOWN).

### 3.3 FIELD QUALITY CONTROL

- A. Manufacturer's field service: Contractor shall arrange and pay for the services of a factory-authorized service representative to supervise the initial start-up, pretesting and adjustment of the fire alarm system.
- B. Prefunctional testing:
  1. Visual and mechanical inspection:
    - a. Inspect for physical damage, defects alignment and fit.
    - b. Perform mechanical operational tests in accordance with Manufacturer's instructions.
    - c. Compare nameplate information and connections to Contract Documents.
    - d. Check tightness of all control and power connections.
    - e. Check that all covers, barriers and doors are secure.
  2. Electrical tests:
    - a. The system shall be completely tested prior to final acceptance testing. All points shall be tested from point of initiation to the final point or points of annunciation. All circuits shall be tested for continuity and ability to transmit the required signal correctly to the FACP. Any problem due to wrong wire type, wire twist, impedance, mismatches, noise filtering or shielding shall be completely corrected during pretesting and prior to any final acceptance tests.
    - b. Testing shall include each and every device in the system. Coordinate with other trades as necessary for testing.
      - 1) Sprinkler flow switches: Record time delay from water flow to alarm and adjust as necessary for a 30-50 second delay.
      - 2) Tamper switches: Verify "trouble "signal is received and alarmed on closing of each valve.

- 3) Smoke detectors , in-duct smoke detectors and duct mounted smoke detectors: Test with actual or approved artificial smoke. Verify that reset does not occur when devices are cleared of smoke. Verify supervisory circuit function. Perform pressure differential test on all duct mounted smoke detectors.
- 4) Door release: Verify that proper alarm activates every held-open door, roll-down doors and shutters, that doors close completely to the closed position.
- 5) Audible/visual notification: Activate by means of an alarm-initiating device that audible and visual devices are clearly audible and/or visual throughout.
- 6) Central station notification: Verify that one set of conductors in the terminal cabinet becomes a short circuit on any "trouble" condition and that the other set becomes a short circuit on any "alarm" condition. Verify that the conductor groups are labeled properly.

c. Test report:

- 1) Provide a complete report listing every device, the date it was tested, the results and the date retested (if failure occurred during the previous test). The test report shall indicate that every device tested successfully.
- 2) Submit two typed copies of the test report in a neatly bound folder for review and approval. Failure to comply with this will result in a delay of final testing and acceptance.

C. Functional performance testing:

1. After the approval of the test report, provide a schedule of final testing. The schedule must be received by the Engineer a minimum of 2 weeks prior to the Final Test Date and must list the dates and time slots in which the various systems can be tested.
2. Coordination of the Final Test dates with all parties (General Contractor, Mechanical Contractor, Elevator Contractor, Owner and others) shall be the sole responsibility of the Contractor. If a party is required to be present during any phase of testing to activate a device, ensure that the party or a qualified representative of the party is present throughout that phase of the testing.

D. In the event that the system fails to function properly during the testing, as a result of inadequate pretesting or preparation, the Contractor shall bear all costs incurred by the necessity for retesting including test equipment, transportation, subsistence and the Engineer's hourly rate.

E. Contractor shall replace at no costs to the Owner all devices which are found defective or do not operate within factory specified tolerances.

3.4 TRAINING

A. Factory authorized service representative shall conduct a two (2) hour training seminar for Owner's Representatives upon completion and acceptance of system. Instructions shall include safe operation, maintenance and testing of equipment with both classroom training and hands-on instruction.

B. Contractor shall schedule training with a minimum of 7 days advance notice.

**END OF SECTION 266113**

## SECTION 27 00 10 - BASIC COMMUNICATIONS REQUIREMENTS

### PART 1 - GENERAL

#### 1.1 SUMMARY

- A. Table of Contents, Division 27 - Communications, Division 28 - Fire Life Safety:

<u>SECTION NO.</u>	<u>SECTION TITLE</u>
27 00 10	BASIC COMMUNICATIONS REQUIREMENTS
27 05 29	COMMUNICATIONS HANGERS AND SUPPORTS
27 05 53	COMMUNICATIONS IDENTIFICATION
27 11 00	COMMUNICATIONS EQUIPMENT ROOMS
27 15 00	COMMUNICATIONS HORIZONTAL CABLING
27 51 23	PUBLIC ADDRESS/INTERCOM SYSTEM

- B. Work included: This Section includes general administrative and procedural requirements for Division 27 and Division 28. The following administrative and procedural requirements are included in this Section to supplement the requirements specified in Division 01.

1. Quality assurance.
2. Definition of terms.
3. Submittals.
4. Coordination.
5. Record documents.
6. Operation and maintenance manuals.
7. Rough-in.
8. Communications installation.
9. Cutting, patching, painting and sealing.
10. Field quality control.
11. Cleaning.
12. Project closeout.

- C. Related Work: Consult all other Sections, determine the extent and character of related Work and properly coordinate Work specified herein with that specified elsewhere to produce a complete and operable installation.

1. General and supplementary conditions: Drawings and general provisions of Contract and Division 01 of the Specifications, apply to all Division 27 Sections.
2. Selective demolition: Nondestructive removal of materials and equipment for reuse or salvage as indicated. Also dismantling communications materials and equipment made obsolete by these installations. Refer to Division 02, Selective Demolition.
3. Concrete Work: Include forming, steel bar reinforcing, cast-in-place concrete, finishing and grouting as required for underground conduit encasement, pull box slabs, vaults, etc. Also includes setting of floor boxes in existing concrete slabs, saw-cutting of existing slabs and grouting of conduits in saw-cut. Refer to Division 03, Concrete.
4. Miscellaneous metal Work: Include fittings, brackets, backing, supports, rods, welding and pipe as required for support and bracing of raceways, cable trays, racks, etc. Refer to Division 05, Miscellaneous Metals.
5. Miscellaneous lumber and framing Work: Include wood grounds, nailers, blocking, fasteners and anchorage for support of communications materials and equipment. Refer to Division 06, Rough Carpentry.
6. Moisture protection and smoke barrier penetrations: Include membrane clamps, sheet metal flashing, counter flashing, caulking and sealant as required for waterproofing of conduit penetrations and sealing penetrations in or through fire walls, floors, ceiling slabs



and foundation walls. All penetrations through vapor barriers at slabs on grade shall be taped and made vaportight. Refer to Division 07, Thermal and Moisture Protection.

7. Access panels and doors: Required in walls, ceilings and floors to provide access to communications devices and equipment. Refer to Division 08, Access Doors also, Division 05, Metals.
  8. Painting: Include surface preparation, priming and finish coating as required for exposed conduit, pull and junction boxes, etc. where indicated as field painted in this Division. Refer to Division 09, Painting.
  9. Conduit: Include conduit and boxes for Interbuilding and Intrabuilding distribution of cabling. Refer to Division 26: 26 05 31, 26 05 33.
- D. Work furnished and installed under another Division requiring connections under this Division includes but is not limited to:
1. Speakers.
  2. Fire alarm control panel.
  3. Temperature control panel(s).
  4. Lighting control panels.
  5. Mechanical control panel.
  6. Security alarm control panel(s).
  7. Access Control.
  8. Cameras.

## 1.2 QUALITY ASSURANCE

- A. Reference to Codes, Standards, Specifications and recommendations of technical societies, trade organizations and governmental agencies shall mean that latest edition of such publications adopted and published prior to submittal of the bid. Such codes or standards shall be considered a part of this Specification as though fully repeated herein.
- B. When codes, standards, regulations, etc. allow Work of lesser quality or extent than is specified under this Division, nothing in said codes shall be construed or inferred authority for reducing the quality, requirements or extent of the Contract Documents. The Contract Documents address the minimum requirements for construction.
- C. Work shall be performed in accordance with all applicable requirements of the latest edition of all governing codes, rules and regulations including but not limited to the following minimum standards, whether statutory or not:
1. California Electric Code (CEC).
  2. California Building Code (CBC).
  3. California Fire Code (CFC).
  4. California Mechanical Code (CMC).
- D. Standards: Equipment and materials specified under this Division shall conform to the following standards where applicable:
- |       |   |
|-------|---|
| ACI   | American Concrete Institute                             |
| ANSI  | American National Standards Institute                   |
| ASTM  | American Society for Testing Materials                  |
| BICSI | Building Industry Consulting Service International, Inc |
| EIA   | Electronics Industries Alliance                         |
| ETL   | Electrical Testing Laboratories                         |
| FCC   | Federal Communications Commission                       |
| ICEA  | Insulated Cable Engineers Association                   |
| IEEE  | Institute of Electrical and Electronics Engineers, Inc  |
| NEMA  | National Electrical Manufacturer's Association          |

NETA	National Electrical Testing Association
NFPA	National Fire Protection Association
TIA	Telecommunication Industry Association
UL	Underwriters' Laboratories

### 1.3 DEFINITIONS

- A. Adapter: Shall mean a connecting device joining two fiber connectors, either like or unlike.
- B. Cabling: A system comprised of cables, wires, cords, and connecting hardware.
- C. Channel: End-to-end transmission path, i.e. the entire portion of the horizontal cabling to each outlet consisting of the Permanent Link, line cord (at the workstation), patch cord, and, if a full crossconnection is implemented, the crossconnect termination/connecting apparatus and equipment cord.
- D. Connect: To install required patch cords, equipment cords, cross-connect wires, etc. to complete an electrical or optical circuit.
- E. Cord: Shall mean length of cordage having connectors at each end. The term "cord" is synonymous with the term "jumper" and "lead."
- F. Identifier: A unique code assigned to an element of the telecommunication infrastructure that links it to its corresponding record.
- G. Passive link segment: Shall mean the cable, connectors, couplings, and splices between two fiber optic termination units.
- H. Permanent link: Test configuration for a horizontal cabling link excluding test cords, connections at the ends of the test cords, patch cords, equipment cords, line cords, etc. The "permanent" portion of the horizontal cabling to each outlet consisting of cable, consolidation point (if used), termination/connecting apparatus in equipment rooms, and the connectors at outlets.
- I. Abbreviations:
  - BEP: Building Entrance Protection, for termination of OSP twisted pair cabling.
  - CAT: Category, used when identifying the performance characteristics of twisted pair cabling.
  - CMP: Communication Media Plenum, rating applied to ISP twisted pair cable.
  - CMR: Communication Media Riser, rating applied to ISP twisted pair cable.
  - IDF: Intermediate Distribution Facilities, telecommunication equipment rooms housing network equipment and containing termination fields for backbone cabling from MDF and horizontal cabling from outlet devices.
  - ISP: Inside Plant, cable installation within building.
  - MDF: Main Distribution Facilities, telecommunication equipment room housing possible service entrance facilities for interbuilding backbone cabling, network equipment, house voice system equipment headend, backbone cabling distribution headend, termination fields for backbone and horizontal cabling.

MMF: Multimode, fiber cable.

MPOE: Minimum Point of Entry, for serving telecommunications utility terminations. House's service provider's termination field(s) and interfaces between utility's facilities and premises facilities.

NAM: Network Access Module, workstations.

OFN: Optical Fiber Non-conductive, general purpose indoor non-plenum rated.

OFNP: Optical Fiber Non-conductive Plenum, plenum rated cable.

OFNR: Optical Fiber Non-conductive Riser, non-plenum rated riser cable.

OSP: Outside Plant, cable installation outside of building.

PIC: Plastic Insulated Conductors.

PVC: Polyvinyl Chloride.

SMF: Singlemode, fiber cable.

UTP: Unshielded Twisted Pair, copper cable type.

#### 1.4 SUBMITTALS

- A. Format: Furnish in format as noted in Division 01.
- B. Submittals shall consist of detailed Shop Drawings, Specifications, block wiring diagrams, "catalog cuts" and data sheets containing physical and dimensional information, performance data, electrical characteristics, materials used in fabrication and material finish. Clearly indicate by arrows or brackets precisely what is being submitted on and those optional accessories which are included and those which are excluded. Furnish quantities of each submittal as noted in Division 01.
- C. Each submittal shall be labeled with the Specification Section Number and shall be accompanied by a cover letter or shall bear a stamp stating that the submittal has been thoroughly reviewed by the Contractor and is in full compliance with the requirements of the Contract Documents. Cover letters shall list in full the items and data submitted. Failure to comply with this requirement shall constitute grounds for rejection of data.
- D. The Contractor shall submit detailed Drawings of all telecommunications equipment rooms and closets if the proposed installation layout differs from the construction documents. Physical size of telecommunications equipment indicated on the Drawings shall match those of the telecommunications equipment that is being submitted for review, i.e.: equipment racks, cable ladder, fuse protectors, ground bars, etc. Minimum scale: 1/4" = 1'- 0". Revised telecommunications equipment layouts must be approved prior to release of order for equipment and prior to installation.
- E. The Manufacturer shall recommend the method of anchoring the equipment to the mounting surface and shall provide the Contractor with the assembly dimensions, weights and approximate centers of gravity.
- F. All re-submittals shall include a cover letter that lists the action taken and revisions made to each Drawing and equipment data sheet in response to Submittal Review Comments. Re-

submittal packages will not be reviewed unless accompanied by this cover letter. Failure to include this cover letter will constitute rejection of the re-submittal package.

- G. All requests for substitution shall conform to the general requirements and procedures outlined in Division 01.

#### 1.5 COORDINATION

##### A. Discrepancies:

1. In the event of discrepancies within the Contract Documents, the Engineer shall be so notified, within sufficient time, as delineated in Division 01, prior to the Bid Opening to allow the issuance of an Addendum.
2. If, in the event that time does not permit notification or clarification of discrepancies prior to the Bid Opening, the following shall apply: The Drawings govern in matters of quantity and the Specifications govern in matters of quality. In the event of conflict within the Drawings involving quantities or within the Specifications involving quantities or within the Specifications involving quality, the greater quantity and higher quality shall apply. Such discrepancies shall be noted and clarified in the Contractor's Bid. No additional allowances will be made because of errors, ambiguities or omissions that reasonably should have been discovered during the preparation of the Bid.

##### B. Project conditions:

1. Examination of Project site: The Contractor shall visit the Project site and thoroughly review the locale, working conditions, conflicting utilities and the conditions in which the Telecommunications Work will take place. Verify all existing conditions in the field. No allowances will be made subsequently for any costs that may be incurred because of any error or omission due to failure to examine the Project site and to notify the Engineer of any discrepancies between Contract Documents and actual Project site conditions.
2. Protection: Keep conduits, junction boxes, outlet boxes and other openings closed to prevent entry of foreign matter. Cover fixtures, equipment, devices and apparatus and protect them against dirt, paint, water, chemical or mechanical damage, before and during construction period. Prior to final acceptance, restore to original condition any fixture, apparatus or equipment damaged including restoration of damaged factory applied painted finishes. Protect bright finished surfaces and similar items until in service. No rust or damage will be permitted.
3. Supervision: Contractor shall personally or through an authorized and competent representative constantly supervise the Work from beginning to completion and, within reason, keep the same foreman and workmen on the Project throughout the Project duration.

##### C. Preparation:

###### Drawings:

- a. Layout: General layout indicated on the Drawings shall be followed except where other Work may conflict with the Drawings.
- b. Accuracy: Drawings for the Work under this Section are essentially diagrammatic within the constraints of the symbology applied.

#### 1.6 RECORD DOCUMENTS

- A. Provide Project Record Drawings as described herein:

1. Drawings shall fully represent installed conditions including actual locations of telecom outlets, patch panels, termination blocks, security panels, security devices, fiber panels, fire alarm panels, intercom systems, clock system, video system, labeling of all components and systems, correct conduit and cabling as well as routing, revised fire alarm schedule listing Manufacturers and products actually installed. Contractor shall record all changes in the Work during the course of construction on black line prints. These prints shall be made subject of monthly review by the Owner's Representative to ascertain that they are current. If not current monthly payments may be withheld.
2. Record Drawings shall be the transfer of information on these prints to the construction documents via computer aided drafting (CAD) or Revit process. A set of electronic Cad or Revit files of the Telecommunications documents will be provided to the Contractor in the design format.
3. Record drawing submissions shall be provided to the Engineer to review upon the completion of the following phases of Work:
  - a. All underground installation.
  - b. Building communications rough-in.
  - c. Final communications installation.
4. A single set of half size prints of the Record Drawings shall be submitted for review. Upon receipt of the Engineer's review comments, corrections shall be made and the Contractor shall provide the following:
  - a. Two sets of full size prints.
  - b. Four sets of half size prints.
  - c. One electronic file of Cad or Revit
  - d. One electronic set in pdf.

#### 1.7 OPERATION AND MAINTENANCE MANUALS

- A. Prior to Project closeout furnish to the Owner, two (2) hard back 3-ring binders containing all bulletins, operation and maintenance instructions, part lists, service telephone numbers and other pertinent information as noted in each Section all equipment furnished under Division 26. Binders shall be indexed into Division Sections and labeled for easy reference. Bulletins containing more information than the equipment concerned shall be properly stripped and assembled.

#### PART 2 - PRODUCTS (NOT APPLICABLE)

#### PART 3 - EXECUTION

##### 3.1 ROUGH-IN

- A. Contractor shall verify lines, levels and dimensions indicated on the Drawings and shall be responsible for the accuracy of the setting out of Work and for its strict conformance with existing conditions at the Project site.
- B. Verify final locations for rough-ins with field measurements and with the requirements for the actual equipment to be connected.
- C. Refer to equipment specification in Divisions 22 through 33 for rough-in requirements.

### 3.2 INSTALLATION

- A. Preparation, sequencing, handling and installation shall be in accordance with Manufacturer's written instructions and technical data particular to the product specified and/or accepted equal except as otherwise specified. Comply with the following requirements:
1. Shop Drawings prepared by Manufacturer.
  2. Verify all dimensions by field measurements.
  3. Arrange for chases, slots and openings in other building components during progress of construction, to allow for telecommunications installations.
  4. Sequence, coordinate and integrate installations of telecommunications materials and equipment for efficient flow of the Work. Give particular attention to large equipment requiring positioning prior to closing in the building.
  5. Where mounting height is not detailed or dimensioned, contact the Architect for direction prior to proceeding with rough-in.
  6. Coordinate connection of telecommunications systems with exterior underground and overhead utilities and services. Comply with requirements of governing regulations, franchised service companies and controlling agencies. Provide required connection for each service.
  7. Install systems, materials and equipment to conform with approved submittal data, including coordination Drawings, to greatest extent possible. Conform to arrangements indicated by the Contract Documents, recognizing that portions of the Work are indicated only in diagrammatic form. Where coordination requirements conflict with individual system requirements, refer conflict to the Architect.
  8. Install systems, materials and equipment level and plumb, parallel and perpendicular to other building systems and components, where installed exposed in finished spaces.
  9. Install telecommunications equipment to facilitate servicing, maintenance and repair or replacement of equipment components. As much as practical, connect equipment for ease of disconnecting, with minimum of interference with other installations.
  10. Coordinate telecommunications systems, equipment and materials installations with other building components.
  11. Provide access panel or doors where devices or equipment are concealed behind finished surfaces. Furnish and install access doors per the requirements of Division 08.
  12. Install systems, materials and equipment giving right-of-way priority to other systems that are required to maintain a specified slope.
  13. Conform to the National telecommunications Contractor's Association "Standard of Installation" for general installation practice.

### 3.3 CUTTING, PATCHING, PAINTING AND SEALING

- A. Structural members shall in no case be drilled, bored or notched in such a manner that will impair their structural value. Cutting of holes, if required, shall be done with core drill and only with the approval of the Architect and Structural Engineer.
- B. Protection of Installed Work: During cutting and patching operations, protect adjacent installations.
- C. Cut, remove and legally dispose of selected telecommunications systems equipment, components and materials as indicated, including but not limited to removal of telecommunications items indicated to be removed and items made obsolete by the new Work.
- D. Protect the structure, furnishings, finishes and adjacent materials not indicated or scheduled to be removed.
- E. Provide and maintain temporary partitions or dust barriers adequate to prevent the spread of dust and dirt to adjacent areas.

- F. Patch existing surfaces and building components using experienced installers and new materials matching existing materials and the original installation. For installers' qualifications refer to the materials and methods required for the surface and building components being patched.
- G. Application of joint sealers:
  - 1. General: Comply with joint sealer Manufacturers' printed application instructions applicable to products and applications indicated, except where more stringent requirements apply.
  - 2. Installation of fire-stopping sealant: Install sealant, including forming, packing and other accessory materials, to fill openings around telecommunications services penetrating floors and walls, to provide fire-stops and fire-resistance ratings indicated for floor or wall assembly in which penetration occurs. Comply with installation requirements established by testing and inspecting agency.

### 3.4 FIELD QUALITY CONTROL

- A. General testing requirements:
  - 1. The purpose of testing is to ensure that all tested telecommunications equipment, both Contractor and Owner supplied, is operational and within industry and Manufacturer's tolerances and is installed in accordance with design Specifications.
  - 2. Tests and inspections shall determine suitability for energization.
  - 3. Perform tests in presence of the Owner's Representative and furnish test equipment, facilities and technical personnel required to perform tests.
  - 4. Contractor shall perform test and provide documentation that the system has passed.
- B. Tests: In addition to specific system test described elsewhere, tests shall include:
  - 1. Equipment operations: Test All systems for proper operation
  - 2. Circuit numbering verification: Select on a random basis various patch panel ports and wire test to verify compliance of the port labeling with actual field wiring.
- C. Contractor shall perform testing on each cable of the Structured Cabling system with test equipment that will provide a full test of the EIA/TIA requirements for the installed category cable and provide test results of each cable under test.
- D. Testing safety and precautions:
  - 1. Safety practices shall include the following requirements:
    - a. Applicable State and Local safety operating procedures.
    - b. OSHA.
    - c. NSC.
    - d. NFPA 70E.
- E. Any products which fail during the tests or are ruled unsatisfactory by the Owner's Representative shall be replaced, by the Contractor. Tests shall be performed after repairs, replacements or corrections until satisfactory performance is demonstrated.
- F. Include all test results in the maintenance manuals.

3.5 CLEANING

- A. Prior to acceptance of telecommunications systems, the Contractor shall thoroughly clean telecommunications rooms from construction debris, scrap wire, etc. using Manufacturer's approved methods and materials.
- B. Upon completion of Project, prior to final acceptance, the Contractor shall thoroughly clean both the interior and exterior of all Telecommunications equipment per Manufacturers approved methods and materials. Remove paint splatters and other spots, dirt and debris.
- C. Touch-up paint any marks, blemishes or other finish damage suffered during installation.

3.6 PROJECT CLOSEOUT

- A. Training: At the time of completion, a period of not less than 2 hours shall be allotted by the Contractor for instruction of building operating and maintenance personnel in the use of all systems. All personnel shall be instructed at one time, the Contractor making all necessary arrangements with Manufacturer's Representative. The equipment Manufacturer shall be requested to provide product literature and application guides for the users' reference. Costs, if any, for the above services shall be paid by the Contractor.
- B. Special tools: Provide one of each tool required for proper operation and maintenance of the equipment provided under this Section. All tools shall be delivered to the Owner at the Project completion.
- C. Keying: Provide two keys for each lock furnished under this Section and turn over to Owner.

**END OF SECTION 27 00 10**



## SECTION 27 05 29 - COMMUNICATIONS HANGERS AND SUPPORTS

### PART 1 - GENERAL

#### 1.1 SUMMARY

- A. Work included: Labor, materials and equipment necessary to complete the installation required for the item specified under this Division, including but not limited to:

1. Materials to support cable runway, cable tray, conduit, junction boxes and terminal cabinets.

- B. Related Work: Consult all other Sections, determine the extent and character of related Work and properly coordinate Work specified herein with that specified elsewhere to produce a complete installation.

1. Division 26: Hangers And Supports
2. Division 27

<u>SECTION NO.</u>	<u>SECTION TITLE</u>
--------------------	----------------------

27 00 10	BASIC COMMUNICATIONS REQUIREMENTS
27 05 53	COMMUNICATIONS IDENTIFICATION
27 11 00	COMMUNICATIONS EQUIPMENT ROOMS
27 15 00	COMMUNICATIONS HORIZONTAL CABLING
27 51 23	PUBLIC ADDRESS/INTERCOM SYSTEM

#### 1.2 REFERENCES

- A. Comply with the latest edition of the following applicable Specifications and standards except as otherwise indicated or specified:

1. American National Standards Institute, Inc. (ANSI):
2. Electronics Industries Alliance (EIA):
3. Factory Mutual System (FM):
4. Federal Communications Commission (FCC) Regulations:
5. Federal Specifications (FS):
6. Institute of Electrical and Electronic Engineers (IEEE):
7. National Electrical Manufacturer Association (NEMA):
8. National Fire Protection Association (NFPA):
9. Telecommunications Industry Association (TIA)
10. Underwriters Laboratories, Inc. (UL):

#### 1.3 DEFINITIONS

- A. Adapter: Shall mean a connecting device joining two fiber connectors, either like or unlike.
- B. Cabling: A system comprised of cables, wires, cords, and connecting hardware.
- C. Channel: End-to-end transmission path, i.e. the entire portion of the horizontal cabling to each outlet consisting of the Permanent Link, line cord (at the workstation), patch cord, and, if a full cross connection is implemented, the cross connect termination/connecting apparatus and equipment cord.
- D. Connect: To install required patch cords, equipment cords, cross-connect wires, etc. to complete an electrical or optical circuit.

- E. Cord: Shall mean length of cordage having connectors at each end. The term “cord” is synonymous with the term “jumper” and “lead.”
- F. Identifier: A unique code assigned to an element of the telecommunication infrastructure that links it to its corresponding record.
- G. Passive link segment: Shall mean the cable, connectors, couplings, and splices between two fiber optic termination units.
- H. Permanent link: Test configuration for a horizontal cabling link excluding test cords, connections at the ends of the test cords, patch cords, equipment cords, line cords, etc. The “permanent” portion of the horizontal cabling to each outlet consisting of cable, consolidation point (if used), termination/connecting apparatus in equipment rooms, and the connectors at outlets.
- I. Abbreviations:
  - 1. BEP: Building Entrance Protection, for termination of OSP twisted pair cabling.
  - 2. CAT: Category, used when identifying the performance characteristics of twisted pair cabling.
  - 3. CMP: Communication Media Plenum, rating applied to ISP twisted pair cable.
  - 4. CMR: Communication Media Riser, rating applied to ISP twisted pair cable.
  - 5. IDF: Intermediate Distribution Facilities, telecommunication equipment rooms housing network equipment and containing termination fields for backbone cabling from MDF and horizontal cabling from outlet devices.
  - 6. ISP: Inside Plant, cable installation within building.
  - 7. MDF: Main Distribution Facilities, telecommunication equipment room housing possible service entrance facilities for interbuilding backbone cabling, network equipment, house voice system equipment headend, backbone cabling distribution headend, termination fields for backbone and horizontal cabling.
  - 8. MMF: Multimode, fiber cable.
  - 9. MPOE: Minimum Point of Entry, for serving telecommunications utility terminations. House’s service provider’s termination field(s) and interfaces between utility’s facilities and premises facilities.
  - 10. NAM: Network Access Module, workstations.
  - 11. OFN: Optical Fiber Non-conductive, general purpose indoor non-plenum rated.
  - 12. OFNP: Optical Fiber Non-conductive Plenum, plenum rated cable.
  - 13. OFNR: Optical Fiber Non-conductive Riser, non-plenum rated riser cable.
  - 14. OSP: Outside Plant, cable installation outside of building.
  - 15. PIC: Plastic Insulated Conductors.
  - 16. PVC: Polyvinyl Chloride.
  - 17. SMF: Singlemode, fiber cable.
  - 18. UTP: Unshielded Twisted Pair, copper cable type.

#### 1.4 SUBMITTALS

- A. Submit in accordance with the requirements of Section 27 00 10: Basic Communications Requirements, the following items:
  - 1. Data/catalog cuts for each product and component specified herein, listing all physical and electrical characteristics and ratings indicating compliance with all listed standards.
  - 2. Shop Drawings to include:
    - a. Plan View of all main pathway systems including:
      - 1) Cable riser systems.
      - 2) Cable Runway

3) J-Hooks

- b. Drawings shall consist of support details and support points of cable tray and cable runway installation.
- 3. Furnish structural calculations for equipment anchorage as described in Section 27 00 10: Basic Communications Requirements.
- 4. Submit Manufacturer's installation instructions.
- 5. Complete Bill of Material listing all components.
- 6. Final test results.
- 7. Warranty.

Dimensions and configurations of equipment shall conform to the space allocated on the Drawings. The Contractor shall submit a revised layout if equipment furnished varies in size from that indicated on Drawings for the Engineer's approval.

1.5 quality assurance

- A. All materials, equipment and parts comprising the units specified herein shall be new, unused and currently under production.
- B. Only products and applications listed in this Section may be used on the Project unless otherwise submitted.
- C. Manufacturer's qualifications:
- D. Installer's qualifications:

1.6 Product delivery, storage and handling

- A. Delivery: Equipment components shall not be delivered to the Project site until protected storage space is available. Storage outdoors covered by rainproof material is not acceptable. Equipment damaged during shipment shall be replaced and returned to manufacturer at no cost to Owner. Components shall be properly packaged in factory-fabricated containers and mounted on shipping skids.
- B. Storage: Store in a clean, dry, ventilated space free from temperature extremes. Maintain factory wrapping or provide a heavy canvas/plastic cover to protect units from dirt, water, construction debris and traffic. Provide heat where required to prevent condensation.
- C. Handling: Handle in accordance with manufacturer's written instructions. Be careful to prevent internal component damage, breakage, denting and scoring. Damaged units shall not be installed. Replace damaged units and return equipment to Manufacturer.

1.7 warranty

- A. Units and components offered under this Section shall be covered by a 1 year parts and labor warranty for malfunctions resulting from defects in materials and workmanship. Warranty shall begin upon acceptance by the Owner.
- B. Provide one spray can of matching finish paint for touching up damaged surfaces after installation.

## PART 2 - PRODUCTS

### 2.1 MANUFACTURERS

- A. Products furnished by the following Manufacturers shall be acceptable if in compliance with all features specified herein and indicated on the Drawings.

### 2.2 MANUFACTURERS

- A. Products furnished by the following Manufacturers shall be acceptable if in compliance with all features specified herein and indicated on the Drawings.

- 1. Concrete fasteners:

- a. Phillips "Red-Head".
    - b. Remington.
    - c. Ramset.

- 2. Concrete inserts and construction channel:

- a. Unistrut Corp.
    - b. GS Metals "Globe Strut."
    - c. Thomas & Betts "Kindorf" Corp.

- 3. Conduit straps:

- a. O-Z/Gedney.
    - b. Erico "Caddy" Fastening Products.
    - c. Thomas & Betts "Kindorf" Corp.

- B. Substitutions: Under provisions of Section 26 00 10: Basic Electrical Requirements.

- C. Substitutions: Under provisions of Section 27 00 10: Basic Communications Requirements.

### 2.3 CONCRETE FASTENERS

- A. Provide expansion-shield type concrete anchors.
- B. Provide powder driven concrete fasteners with washers. Obtain approval by Architect and Structural Engineer prior to use.

### 2.4 CONCRETE INSERTS

- A. Provide pressed galvanized steel, concrete spot insert, with oval slot capable of accepting square or rectangular support nuts of  $\frac{1}{4}$  inch to  $\frac{1}{2}$  inch diameter thread for rod support.

### 2.5 THREADED ROD

- A. Provide steel threaded rod, sized for the load unless otherwise noted on the Drawings or in the Specifications.

### 2.6 CONSTRUCTION CHANNEL

- A. Provide 1-1/2 inch by 1-1/2 inch (nominal), 12 gauge galvanized steel channel with 17/32-inch diameter bolt holes and 1-1/2 inch on center in the base of the channel.

## 2.7 CONDUIT STRAPS

- A. One hole strap, steel or malleable iron, with malleable iron clamp-back spacer for surface mounted wall and ceiling applications.
  - 1. Use malleable strap with spacers for exterior and wet locations.
  - 2. Use steel strap without spacers for interior locations.
- B. Steel channel conduit strap for support from construction channel.
- C. Steel conduit hanger for pendant support with threaded rod
- D. Steel wire conduit support strap for support from independent #12 gauge hanger wires.
- E. Factory testing:

## PART 3 - EXECUTION

### 3.1 EXAMINATION

- A. Contractor shall thoroughly examine Project site conditions for acceptance of supporting device installation to verify conformance with Manufacturer and Specification tolerances. Do not commence with installation until all conditions are made satisfactory.

### 3.2 PREPARATION

- A. Coordinate size, shape and location of concrete pads with Division 03, Cast-in-place concrete.
- B. Layout support devices to maintain headroom, neat mechanical appearance and to support the equipment loads.

### 3.3 INSTALLATION

- A. Furnish and install supporting devices as noted throughout Division 27 and Division 28.
- B. Telecommunication, Security, Fire Alarm and other system devices and conduit supports shall be independent of all other system supports that are not structural elements of the building, unless otherwise noted.
- C. Fasten hanger rods, conduit clamps, outlet and junction boxes to building structure using precast inserts, expansion anchors, preset inserts or beam clamps.
- D. Use toggle bolts or hollow wall fasteners in hollow masonry, plaster or gypsum board partitions and walls.
- E. Use expansion anchors or preset inserts in solid masonry walls.
- F. Use self-drilling anchors, expansion anchor or preset inserts on concrete surfaces.
- G. Use sheet metal screws in sheet metal studs and wood screws in wood construction.
- H. Do not fasten supports to piping, ductwork, mechanical equipment, conduit or acoustical ceiling suspension wires.
- I. Do not drill structural steel members unless first approved in writing by the Architect or Structural Engineer.

- J. Fabricate supports from structural steel or steel channel, rigidly welded or bolted to present a neat appearance. Use hexagon head bolts with spring lock washers under all nuts.
- K. Install surface-mounted cabinets with minimum of four anchors. Provide additional support backing in stud walls prior to sheet rocking as required to adequately support cabinets and panels.
- L. Bridge studs top and bottom with channels to support flush mounted cabinets in stud walls.

#### 3.4 ERECTION OF METAL SUPPORTS

- A. Cut, fit and place miscellaneous metal fabrications accurately in location, alignment and elevation to support and anchor electrical materials and equipment.
- B. Field Welding: Comply with AWS "Structural Welding Code."

#### 3.5 WOOD SUPPORTS

- A. Wood supports are not allowed on this project.

#### 3.6 ANCHORAGE

- A. All floor mounted, free standing telecommunications equipment such as racks and cabinets etc... shall be securely fastened to the floor structure.

**END OF SECTION 27 05 29**

## SECTION 27 05 53 - COMMUNICATIONS IDENTIFICATION

### PART 1 - GENERAL

#### 1.1 SUMMARY

- A. Work included: Labor, materials and equipment necessary to complete the installation required for the item specified under this Division, including but not limited to:
1. Identification Requirements and Labeling Systems - General
  2. Identification Requirements and Labeling Systems - Equipment Racks
  3. Identification Requirements and Labeling Systems - Equipment Cabinets
  4. Identification Requirements and Labeling Systems - Fuse Protectors
  5. Identification Requirements and Labeling Systems - Vertical & Horizontal Wire Managers

- B. Related Work: Consult all other Sections, determine the extent and character of related Work and properly coordinate Work specified herein with that specified elsewhere to produce a complete installation.

<u>SECTION NO.</u>	<u>SECTION TITLE</u>
27 00 10	BASIC COMMUNICATIONS REQUIREMENTS
27 05 29	COMMUNICATIONS HANGERS AND SUPPORTS
27 11 00	COMMUNICATIONS EQUIPMENT ROOMS
27 15 00	COMMUNICATIONS HORIZONTAL CABLING
27 51 23	PUBLIC ADDRESS/INTERCOM SYSTEM

#### 1.2 references

- A. Comply with the latest edition of the following applicable Specifications and standards except as otherwise indicated or specified:
1. American National Standards Institute, Inc. (ANSI):
  2. Electronics Industries Alliance (EIA):
  3. Factory Mutual System (FM):
  4. Federal Communications Commission (FCC) Regulations:
  5. Federal Specifications (FS):
  6. Institute of Electrical and Electronic Engineers (IEEE):
  7. National Electrical Manufacturer Association (NEMA):
  8. National Fire Protection Association (NFPA):
  9. Telecommunications Industry Association (TIA)
  10. Underwriters Laboratories, Inc. (UL):

#### 1.3 SUBMITTALS

- A. Submit in accordance with the requirements of Section 26 00 10: Basic Electrical Requirements, the following items:
1. Data/catalog cuts for each product and component specified herein.
  2. Schedules for nameplates to be furnished.

#### 1.4 quality assurance

- A. All materials, equipment and parts comprising the units specified herein shall be new, unused and currently under production.
- B. Only products and applications listed in this Section may be used on the Project unless otherwise submitted.

## PART 2 - PRODUCTS

### 2.1 MANUFACTURERS

A. Products furnished by the following Manufacturers shall be acceptable if in compliance with all features specified herein and indicated on the Drawings.

1. Identification Requirements and Labeling Systems:

- a. Brady.
- b. Panduit.
- c. Tyton

2. Equipment Racks:

- a. Chatsworth.
- b. B-Line.
- c. Panduit.
- d. Ortronics

3. Equipment Cabinets:

- a. Chatsworth.
- b. Great Lakes.
- c. Panduit.
- d. Ortronics

4. Fuse Protectors:

- a. Porta Systems.
- b. Circa.
- c. Systemex.

5. Vertical & Horizontal Wire Managers:

- a. Chatsworth.
- b. B-Line.
- c. Panduit.

B. Substitutions: Under provisions of Section 27 00 10: Basic Communications Requirements.

### 2.2 NAMEPLATES

A. Type NP: Engraved, plastic laminated labels, Signs and Instruction Plates. Engrave stock melamine plastic laminate 1/16-inch minimum thickness for signs up to 20 square inches or 8 inches in length; 1/8 inch thick for larger sizes. Engraved nameplates shall have white letters and be punched for mechanical fasteners.

B. Color and letter height as specified in Part 3: Execution.

### 2.3 INSCRIBED DEVICE COVERPLATES

A. Coverplate material shall be as specified in Section 26 27 26: Wiring Devices.

B. Methods of inscription: (Unless otherwise noted)

1. Type-on-tape:



- a. Imprinted or thermal transfer characters onto tape lettering system.
- b. Tape trimmer.
- c. Matte finish spray-on clear coating.

## PART 3 - EXECUTION

### 3.1 EXAMINATION

- A. Contractor shall thoroughly examine Project site conditions for acceptance of switchboard installation to verify conformance with Manufacturer and Specification tolerances. Do not commence with installation until all conditions are made satisfactory.

### 3.2 APPLICATION

- A. Identification Requirements and Labeling Systems - General
- B. Identification Requirements and Labeling Systems - Equipment Racks
- C. Identification Requirements and Labeling Systems - Equipment Cabinets
- D. Identification Requirements and Labeling Systems - Fuse Protectors
- E. Identification Requirements and Labeling Systems - Vertical & Horizontal Wire Managers

### 3.3 NAMEPLATES

- A. Installation:
  - 1. Degrease and clean surfaces to receive nameplates.
  - 2. Install nameplates parallel to equipment lines.
  - 3. Secure nameplates to equipment fronts using machine screws.
- B. Provide type 'NP' color coded nameplates that present, as applicable, the following information:  
System and Equipment designations
- C. Nameplates for signal systems equipment and devices are to be black except as follows:
  - 1. Fire alarm and life safety - Red
  - 2. Security/card access/CCTV systems - Green
  - 3. Clock, intercom, sound, MATV, CATV - Blue

### 3.4 INSCRIBED DEVICE COVERPLATE

- A. General:
  - 1. Lettering type: Helvetica, 12 point or 1/8" high.
  - 2. Color of characters shall be black.
  - 3. Locate the top of the inscription 1/2" below the top edge of the coverplate.
  - 4. Inscription shall be centered and square with coverplate.
- B. Application:
  - 1. Provide inscribed coverplates for devices as outlined below:
    - a. Telecommunication outlets.

2. Type-on-tape inscriptions shall be provided for the following devices:
  - a. Telecommunication outlets.
3. Type-on-tape installation:
  - a. Tape shall be trimmed to the height of the letters.
  - b. Trim tape length to 1/4 inch back from each edge of coverplate.
  - c. Contractor hands shall be clean or covered with surgical type glove prior to application of tape. Tape installations with visible fingerprints or smudges will not be acceptable.

### 3.5 CLEANING

- A. Upon completion of Project prior to final acceptance the Contractor shall thoroughly clean all equipment per Manufacturers approved methods and materials. Remove paint splatters and other spots, dirt and debris.
- B. Touch-up paint any marks, blemishes or other finish damage suffered during installation.

**END OF SECTION 27 05 53**

## SECTION 27 11 00 - COMMUNICATIONS EQUIPMENT ROOMS

### PART 1 - GENERAL

#### 1.1 SUMMARY

- A. Work included: Labor, materials and equipment necessary to complete the installation required for the item specified under this Division, including but not limited to:
1. Equipment racks.
  2. Vertical cable management.
  3. Horizontal cable support.
  4. Cable runways.
- B. Related Work: Consult all other Sections, determine the extent and character of related Work and properly coordinate Work specified herein with that specified elsewhere to produce a complete installation.
1. Drawings and general provisions of the Contract, including General and Supplementary Conditions and Division 1 Specification Sections, apply to this Section.

<u>SECTION NO.</u>	<u>SECTION TITLE</u>
27 00 10	BASIC COMMUNICATIONS REQUIREMENTS
270529	COMMUNICATIONS HANGERS AND SUPPORTS
270553	COMMUNICATIONS IDENTIFICATION
271500	COMMUNICATIONS HORIZONTAL CABLING
275123	PUBLIC ADDRESS/INTERCOM SYSTEM

#### 1.2 REFERENCES

- A. Comply with the latest edition of the following applicable Specifications and standards except as otherwise indicated or specified:
1. American National Standards Institute, Inc. (ANSI):
  2. Electronics Industries Alliance (EIA):
  3. Factory Mutual System (FM):
  4. Federal Communications Commission (FCC) Regulations:
  5. Federal Specifications (FS):
  6. Institute of Electrical and Electronic Engineers (IEEE):
  7. National Electrical Manufacturer Association (NEMA):
  8. National Fire Protection Association (NFPA):
  9. Telecommunications Industry Association (TIA)
  10. Underwriters Laboratories, Inc. (UL):

#### 1.3 DEFINITIONS

- A. Above finish floor (AFF) - Standard mounting height (e.g., 18 inch AFF) for a device using the center line of the device as the measurement point.
- B. Administration - The methodology defining the documentation requirements of a cabling system and its containment, the labeling of functional elements and the process by which moves, additions, and changes are recorded.
- C. ANSI/TIA/EIA - Associations involved in developing telecommunications industry standards.

- D. Attenuation - The decrease in magnitude of transmission signal strength between points, expressed in dB as the ratio of output to input signal level.
- E. Attenuation-to-crosstalk ratio (ACR) - The ratio obtained by subtracting insertion loss (attenuation [dB]) from near-end crosstalk (dB). ACR is normally stated at a give frequency.
- F. Auditory assistance device - An intentional radiator used to provide auditory assistance to a handicapped person or persons. Such a device may be used for auricular training in an educational institution, for auditory assistance at places of public gatherings, such as a church, theater, or auditorium, and for auditory assistance to handicapped individuals, only, in other locations.
- G. Backboard - Backboard generally refers to the 3/4" A-C grade plywood sheeting, lining the walls of the telecommunications room. Plywood shall be void-free, with two coats of fire retardant paint matching the painted interior walls covering both sides.
- H. Backbone - A facility (e.g., pathway, cable, or conductors) between any of the following spaces: telecommunications rooms, common telecommunications rooms, floor-serving terminals, entrance facilities, equipment rooms, and common equipment rooms.
- I. Basic link test configuration - Horizontal cable of up to 90m (295 ft) plus up to 2m (6.5 ft) of test equipment cord from the main unit of the tester to the local connection, and up to 2m (6.5 ft) of test equipment cord from the remote connection to the remote unit of the tester. Maximum length is 94 m (308 ft).
- J. Bonding Conductor (BC) - A conductor used specifically for the purpose of bonding.
- K. Cable Labeling System:
  - 1. The scheme employed when identifying cable or its associated hardware.
  - 2. Scheme adapted for labeling cables to identify them based on ANSI/TIA/ EIA-606-A, Administration Standard for Commercial Telecommunications Infrastructure. See administration.
- L. Cable Runway - Hardware designed and manufactured for horizontal pathway distribution of cable and inside wiring inside the MC, IC, or TR rooms.
- M. CAT - Category used when identifying the performance characteristics of twisted pair cabling.
- N. Ceiling Distribution System - A distribution system that utilizes the space between a suspended or false ceiling and the structural surface above.
- O. Closed-Circuit Television (CCTV) - A private television system, typically used for security purposes, in which the signal is transmitted to a limited number of receivers.
- P. Communications plenum cable (CMP) - Type CMP communications plenum cable shall be listed as being suitable for use in ducts, plenums, and other spaces used for environmental air and shall also be listed as having adequate fire-resistant and low smoke-producing characteristics. (NEC)Cables must pass required test for fire and smoke characteristics of wires and cables, NFPA 262 or UL 910.
- Q. Communications Riser Cable (CMR) - Type CMR communications riser cable shall be listed as being suitable for use in a vertical run in a shaft or from floor to floor and shall also be listed as having fire-resistant characteristics capable of preventing the carrying of fire from floor to floor. (NEC) Cables must pass requirements for flame propagation.

- R. Electromagnetic Interference (EMI) - Radiated or conducted electromagnetic energy that has an undesirable effect on electronic equipment or signal transmissions.
- S. Entrance Conduit - Conduit that connects the campus underground infrastructure with the building's Telecommunications Room.
- T. Fire Retardant - Any substance added to delay the start or ignition of fire or slow the spread of the flame of any material.
- U. Firestopping - The process of installing [specialty] listed fire-rated materials into penetrations of fire-rated barriers to reestablish the fire-resistance rating of the barrier.
- V. Firestopping Location. A penetration through a fire-rated wall with a sleeve.
- W. Firestop System - A specific installation consisting of the material(s) (firestop penetration seals) that fill the opening in the wall or floor assembly, and around and between any items that penetrate the wall or floor (e.g., cables, cable trays, conduit, ducts, pipes), and any termination devices (e.g., electrical outlet boxes) along with their means of support.
- X. Grounding Conductor - A conductor used to connect the grounding electrode to the buildings main grounding busbar.
- Y. Grounding System - A system of hardware and wiring that provides an electrical path from a specified location to an earth ground point.
- Z. Horizontal Cabling - The part of the cabling system that extends from the work area telecommunications outlet to the horizontal cross-connect in the telecommunications room.
- AA. Hybrid Cable - An assembly of two or more cables, of the same or different types or categories, covered by one overall sheath.
- BB. Infrastructure (Telecommunications) - A collection of those telecommunications components, excluding equipment, that together provide the basic support for the distribution of all information within a building or campus.
- CC. Intermediate Cross-connect (IC) - the connection point between a backbone cable that extends from the main cross-connect and the backbone cable from the horizontal cross-connect.
- DD. Loose Tube - A type of optical fiber cable construction where one or more fibers are laid loosely in a tube. Also called loose tube fiber.
- EE. Main Cross-connect (MC) - The cross-connect normally located in the Telecommunications Equipment Room for cross-connection and interconnection of entrance cables, first-level backbone cables, and equipment cables.
- FF. Metropolitan Area Network (MAN) - A data communications network that covers an area larger than a campus area and smaller than a wide area network. Typically interconnects two or more LANs and usually covers an entire metropolitan area.
- GG. MPOE - Minimum Point of Entry, Utility Partnerships/Alternate Carrier, usually located within the Telecommunications Room.
- HH. Multimode Fiber (MMF) - An optical fiber that carries many paths of light or an optical waveguide that allows many bound modes to propagate.

- II. Single-mode Fiber (SMF) - An optical fiber, usually step-index grade, which supports only one mode of light propagation. This does not necessarily imply single wavelength operation. The light source is normally a laser.
- JJ. Strand (STR) - A single unit of optical fiber within a cable (e.g., a 12-strand fiber cable has 12 individual optical fibers within the cable sheath).
- KK. Telecommunications Entrance Facility - Utility Partnerships/Alternate Carrier Minimum Point of Entry that is usually located within the Main Cross-connect Room (MC).
- LL. Telecommunications Equipment Room (TER) - A centralized space that provides space and maintains a suitable operating environment for the termination of backbone and campus cabling and house centralized communications and/ or computer equipment (such as Core Switches and Servers). *Note:* An equipment room is considered distinct from a telecommunications closet because of the nature or complexity of the equipment housed by the equipment room.
- MM. Telecommunications Main Grounding Busbar (TMGB) - A grounding busbar, located in the MC, connected to the main building ground electrode by a continuous 2/0 - #4 AWG wire (Wire size is dependent on the distance between the busbar and the building main).
- NN. Telecommunications Room (TR) – A room dedicated to housing a group of telecommunications connectors (e.g., patch panel or punch-down block) that allows equipment and backbone cabling to be cross connected with patch cords or jumpers.
- OO. Underwriters Laboratories (UL) - A United States-based independent testing laboratory that sets safety tests and standards.
- PP. Uninterruptible Power Supply (UPS) - A device that is inserted between a primary power source (e.g., a commercial utility) and the primary power input of equipment to be protected (e.g., a computer system) to eliminate the effects of transient variances or temporary outages. Retain acronyms, abbreviations, and terms that remain after this Section has been edited.

#### 1.4 SYSTEM DESCRIPTION

- A. The construction of cable runway, equipment racks and plywood backboards to support communications equipment, cabling, and termination hardware.
- B. Grounding sub-system for bonding of equipment racks, cable runway, entrance cable, riser cable and conduits within the equipment room.

#### 1.5 SUBMITTALS

- A. Items specified under this Section are Priority 1. Refer to Section 27 00 10: Basic Communications Requirements for specific Priority 1 requirements.
- B. Submit in accordance with the requirements of Section 27 00 10: Basic Communications Requirements, the following items:
  - 1. Data/catalog cuts for each product and component specified herein, listing all physical and electrical characteristics and ratings indicating compliance with all listed standards.
  - 2. Shop Drawings to include:
    - a. Enlarged equipment room plans of the racks, cabinets, overhead runway and conduit stubs into adjoining spaces.
    - b. Wall and Rack Elevations with scaled components.

3. Furnish structural calculations for equipment anchorage as described in Section 27 00 10: Basic Communications Requirements.
4. Submit Manufacturer's installation instructions.
5. Complete Bill of Material listing all components.
6. Final test results.
7. Warranty.

- C. Dimensions and configurations of equipment shall conform to the space allocated on the Drawings. The Contractor shall submit a revised layout if equipment furnished varies in size from that indicated on Drawings for the Engineer's approval.

#### 1.6 OPERATION AND MAINTENANCE MANUALS

- A. Supply operation and maintenance manuals in accordance with the requirements of Section 27 00 10: Basic Communications Requirements, to include the following:

1. A detailed explanation of the operation of the system.
2. Instructions for routine maintenance.
3. Pictorial parts list and part numbers.
4. Pictorial and schematic Electrical Drawings of wiring systems, including operating and safety devices, control panels, instrumentation and annunciators.
5. Telephone numbers for the authorized parts and service distributors.
6. Include all service bulletins and torque Specifications for all terminations.
7. Final testing report.

#### 1.7 QUALITY ASSURANCE

- A. All materials, equipment and parts comprising the units specified herein shall be new, unused and currently under production.
- B. Only products and applications listed in this section may be used on the Project unless otherwise submitted.
- C. Manufacturer qualifications: Manufacturer must have a minimum 5 continuous years of experience in design and manufacturing of the materials and equipment specified herein.
- D. Installer's qualifications:
1. Installer must have a minimum 5 continuous years of experience in satisfactory completion for Projects similar in scope and cost. Provide backup information on 5 such Projects.
  2. Installer shall possess a current, active and valid C7 or C10 California State Contractors License.

#### 1.8 PRODUCT DELIVERY, STORAGE AND HANDLING

- A. Delivery: Equipment components shall not be delivered to the Project site until protected storage space is available. Storage outdoors covered by rainproof material is not acceptable. Equipment damaged during shipment shall be replaced and returned to manufacturer at no cost to Owner. Components shall be properly packaged in factory-fabricated containers and mounted on shipping skids.
- B. Storage: Store in a clean, dry, ventilated space free from temperature extremes. Maintain factory wrapping or provide a heavy canvas/plastic cover to protect units from dirt, water, construction debris and traffic. Provide heat where required to prevent condensation.

- C. Handling: Handle in accordance with manufacturer's written instructions. Be careful to prevent internal component damage, breakage, denting and scoring. Damaged units shall not be installed. Replace damaged units and return equipment to Manufacturer.warranty
- D. Units and components offered under this Section shall be covered by a 1 year parts and labor warranty for malfunctions resulting from defects in materials and workmanship. Warranty shall begin upon acceptance by the Owner.

1.9 EXTRA MATERIAL:

- A. Provide one spray can of matching finish paint for touching up damaged surfaces after installation.

PART 2 - PRODUCTS

2.1 MANUFACTURERS

- A. Products furnished by the following Manufacturers shall be acceptable if in compliance with all features specified herein and indicated on the Drawings.

- 1. Equipment racks and cable runways:

- a. Cooper B-Line

- 2. Bonding strap:

- a. Cooper B-Line

- 3. Bonding connectors and lugs:

- a. Cooper B-Line

2.2 EQUIPMENT RACKS, 2 CHANNEL TYPE:

- A. Application: Suitable for the support of termination apparatus, cable and cord management apparatus, network equipment, and other similar equipment within a telecommunication room.

- B. Material: High-strength, lightweight, #6061-T6 extruded aluminum construction, 11 Ga. ASTM A570 steel uprights and ASTM A36 steel angles.

- C. Channel:

- 1. Size: 3" deep with flanges on each side (double sided).
- 2. Flange: 1.265" wide by 0.25" thick with mounting holes.
- 3. Mounting holes: Threaded mounting holes at #12-24 rolled and spaced 5/8"-5/8"-1/2", compatible with ANSI/EIA-310-D.
- 4. RMU markings: The RMU markings shall be permanently stamped on the outside of both flanges on both channels.

- D. Assembled rack: Rack shall be complete with two mounting channels, two base angles (3.5" high by 6" deep by 0.375" thick), two top angles (1.5" high by 1.5" deep by 0.375" thick). Rack shall be 7'-0" high (overall) by 19" mounting width (20.25" width overall and shall contain 45 EIA mounting spaces (1.75" on center).

- E. Load rating: 1000 lbs, when evenly distributed for the height of rack.



- F. Finish: Powder coat, black.
- G. Accessories: Include required accessories, such as floor installation kits, mounting hardware, etc. for a complete installation.
- H. Rack Model & Part Number:
  - 1. Standard Rack 3"D
  - 2. Part #SB556084XUFB

### 2.3 EQUIPMENT RACKS, 4 CHANNEL TYPE:

- A. Application: Suitable for the support of termination apparatus, cable and cord management apparatus, network equipment, and other similar equipment within a telecommunication room.
- B. Material: High-strength, lightweight, #6061-T6 extruded aluminum construction, 11 Ga. ASTM A570 steel uprights and ASTM A36 steel angles.
- C. Channel:
- D. Size: 3" deep with flanges on each side (double sided).
- E. Flange: 1.265" wide by 0.25" thick with mounting holes.
- F. Mounting holes: Threaded mounting holes at #12-24 rolled and spaced 5/8"–5/8"–1/2", compatible with ANSI/EIA-310-D.
- G. RMU markings: The RMU markings shall be permanently stamped on the outside of both flanges on both channels.
- H. Assembled rack: Rack shall be complete with four rack channels, two base angles (3.5" high by 6" deep by 0.375" thick), two top angles (1.5" high by 1.5" deep by 0.375" thick), one extension pan set, Rack shall be 7'-0" high (overall) by 19" mounting width (20.25" width overall, 29" deep and shall contain 45 EIA mounting spaces (1.75" on center).
- I. Load rating: 2000 lbs, when evenly distributed for the height of rack.
- J. Finish: Powder coat, black.
- K. Accessories: Include required accessories, such as floor installation kits, mounting hardware, etc. for a complete installation.
- L. Rack Model & Part Number:
- M. 4 Post Standard Rack
- N. Part #SB837084CFB

### 2.4 VERTICAL MANAGEMENT SECTION:

- A. Application: Suitable for cable routing (back) and cord slack storage (front) vertically within a rack bay, from bottom of rack to the top.
- B. Configuration: The vertical management sections shall be double-sided having covered cable guides on the front and on the rear.

- C. Size and capacity between racks: 80" high by 5" wide.
- D. Mounting: The vertical management sections shall have matching bolt holes for attachment to equipment rack.
- E. Finish: Black, guide and cover.
- F. Part Number:
  - 1. Leviton Vertical Cable Manager
    - a. 5"W X 40"L - Part #4940L-VFR

## 2.5 HORIZONTAL MANAGEMENT SECTION:

- A. Application: Suitable for cable routing (front and rear) and cord slack storage horizontally within a rack bay.
- B. Mounting: The horizontal management sections shall have matching bolt holes for attachment to equipment rack.
- C. Finish: Black, guide, and cover
- D. Part Number:
  - 1. Leviton Horizontal Cable Manager
    - a. Part #492RU-HFR

## 2.6 CABLE RUNWAY SYSTEM

- A. Runway type cable ladders shall consist of two longitudinal members (stringers) with adjustable transverse members (rungs) connected to the stringers. Rungs shall have a minimum cable bearing surface of 1" with radius edges. No portion of the rungs shall protrude below the bottom plane of the side rails.
- B. Straight cable runway sections shall have side rails fabricated as tubular steel channels. All straight sections shall be supplied in standard 10' foot lengths, except where shorter lengths are permitted to facilitate cable runway assembly lengths as shown on drawings.
- C. Cable runway widths shall be 12" inches as indicated on drawings.
- D. Splice plates shall be the bolted type made as indicated below for each cable ladder type. The resistance of fixed splice connections between an adjacent section of cable runway shall not exceed .00033 ohm. Splice plate construction shall be such that a splice may be located anywhere within the support span without diminishing the cable ladder rated loading capacity.
- E. All splice materials shall be made of ASTM A570 structural steel using carriage bolts and serrated flange locknuts. Hardware shall be powder coated black.
- F. Cable runway Supports: Shall be placed so that the support spans do not exceed a maximum span of 5' feet. Supports shall be constructed from formed shape channel members 1 5/8" x 1 5/8" with necessary hardware such as trapeze support kits, ceiling support kits, triangular support brackets, wall angle support kits, cable drop outs, etc... as provided by the same manufacturer.

- G. Trapeze hangers shall be supported by 5/8" (minimum) diameter all thread rods. All thread rods shall be equipped with threaded rod covers to protect cable from damage during installation.
- H. Accessories - special accessories shall be furnished as required to protect, support, and install a cable ladder system. Accessories shall consist of but are not limited to; section splice plates, expansion plates, blind-end plates, specially-designed ladder drop-outs, barriers, etc.
- I. All cable runway, splice hardware, and support hardware shall be powder coated black.

## 2.7 LOADING CAPACITIES

- A. Cable ladders shall meet NEMA class designations: 8A.

## 2.8 LABEL PLATES FOR EQUIPMENT RACKS:

- A. Label plates shall be suitable to affix onto top angle of equipment rack.
- B. Label plate shall be "engrave-able" stock melamine plastic laminate substrate.
- C. Size: 1/2" high by 6" long by 1/16" thick.
- D. Lettering shall be white, engraved, 1/8" high.
- E. Model and Part #:
  - 1. Model UL Classified Cable Runway
  - 2. B-Line Redi-Rail
    - a. Part #SB13AL12FB

## 2.9 PLYWOOD BACKBOARDS

- A. Application: Plywood backboards shall be placed on all walls of the telecommunications equipment room to 100" AFF. Bottom of plywood shall be 4" AFF The plywood will support wall mounted equipment, termination blocks, ladder support, etc...
  - 1. Plywood backboards shall be A-C grade, 3/4"x8'Hx4'W, void free and sanded one side.
  - 2. Paint plywood with 2 coats of fire retardant paint on both sides and edges. Color to match painted interior.

## 2.10 CONDUIT SLEEVES

- A. Application: Sleeves between the telecom room and adjacent ceiling for conveying cable to cable tray or J-hooks.
- B. Conduit shall be 4" EMT with bushings
- C. Each conduit shall be equipped with a 4" conduit waterfall.
  - a. Panduit #CWF400

## PART 3 - EXECUTION

### 3.1 EXAMINATION

- A. Contractor shall thoroughly examine Project site conditions for acceptance of equipment installation to verify conformance with Manufacturer and Specification tolerances. Do not commence with installation until all conditions are made satisfactory.

### 3.2 APPLICATION

- A. Provide support equipment in telecommunications equipment rooms to support cable infrastructure, network equipment, horizontal cabling, patch cords and entrance cable.

### 3.3 EQUIPMENT RACKS AND WALL-MOUNTED ENCLOSURES

- A. Installation
- B. Equipment racks shall be mounted to the floor using drop-in type anchors.
  - 1. Mount equipment racks per dimensions stated on the construction drawings to allow proper clearances and preserve future growth.
  - 2. Equipment racks shall be mounted square and level.
  - 3. Equipment racks shall be supported laterally by the cable runway which is mounted to the equipment room wall.
  - 4. Each equipment rack shall be grounded to the Telecommunication Grounding Bus bar with a dedicated #6 AWG wire. Daisy-chaining racks are not allowed.
  - 5. Wall-mounted enclosures shall be mounted to the wall studs at six places minimum. Pre-drill plywood backboards prior to mounting to assure proper stud anchoring.
  - 6. Wall-mounted enclosures shall be mounted level and mounting rails installed with 6" of clearance to the front of enclosure door.
  - 7. Wall-mounted enclosures shall be mounted so they can swing open with proper clearances. Cables shall maintain proper slack to allow opening of enclosures.
  - 8. Wall-mounted enclosures shall be grounded to an electrical panel ground bus with a #6 AWG wire.

### 3.4 CABLE MANAGEMENT

- A. Vertical Managers
  - 1. All equipment racks shall contain vertical managers between racks and on each end of racks.
  - 2. Attach managers securely to equipment racks.
  - 3. Provide cable protection with radius drops or plastic inserts into managers that allow cables to be free of kinks or cuts.
- B. Horizontal Managers
  - 1. All equipment racks shall contain horizontal managers between all patch panels and equipment.
  - 2. Secure managers with at least four rack screws.
  - 3. Utilize managers on the backs of all premises cable equipment racks to properly dress cable terminations.

### 3.5 CABLE RUNWAY

- A. Installation

1. All cable ladder will be installed in spaces indicated on drawings. Cable ladder is not acceptable in the space above the ceiling for distribution of horizontal cable runs.
2. Install cable ladders as indicated; in accordance with equipment manufacturer's instructions, and with recognized industry practices, to ensure that cable ladder equipment comply with requirements of CEC, and applicable portions of NFPA 70b and NECA's "Standards of Installation" pertaining to general electrical installation practices.
3. All cable ladder shall be supported from the ceiling structure and at top of cabinets. Horizontal Cable ladder shall not be supported from the wall.
4. Provide dimensional structural restraints around the cable ladder for transverse and longitudinal bracing.
5. Coordinate cable ladder with other electrical work as necessary to properly interface installation of cable ladder work with other work.
6. Provide sufficient space encompassing cable ladders to permit access for installing and maintaining cables.
7. Ground all cable ladder to the communications room bus bars. Use ground straps between each section of runway installed or where splice plates are used to join sections. Scrape paint away from cable runway at points of connection to each section of runway by the ground strap.

B. Testing

1. Demonstrate compliance with specified maximum grounding resistance. Refer to NFPA70B, Chapter 18, for testing and test methods.

3.6 FIBER OPTIC AND COPPER PATCH PANELS

- A. Mount all patch panels securely with at least four rack screws.
- B. All patch panels shall be labeled accordingly. The panel located at the top of the equipment rack shall be 01, and then 02, 03, etc.
- C. All patch panels shall have the cables that reside in the patch panel clearly identified. This shall be accomplished with self adhesive, machine printed labels.
- D. All fiber patch panels shall be fully populated with fiber coupling mounting plates or blank mounting plates.

3.7 PLYWOOD BACKBOARDS

- A. Mount bottom of plywood backboards 3" AFF and to 100" above Finished Floor.
- B. Secure plywood to wall studs 12"OC vertically, 16" OC horizontally and within 2" from top & bottom edge of plywood.
- C. Use #12 galvanized flat head screws with 2.5" min. embedment. Use wood screws into wood studs, Self Drilling Screws into metal studs, and concrete anchors into concrete.

3.8 CONDUIT SLEEVES

- A. Mount above ceiling through non-rated wall
- B. Secure to wall material on each side of structure with conduit mounting brackets. conduit shall be have 6" min. on each side of wall. Place bushings on both ends of conduit.
- C. Provide 3" of sound insulation into sleeves at each end after installation of cable.

### 3.9 FIELD QUALITY CONTROL

- A. At least three weeks prior to any testing, notify the Engineer so that arrangement can be made for witnessing test, if deemed necessary. All pretesting shall have been tested satisfactorily prior to the Engineer's witnessed test.
- B. Test cable ladder, & racks to ensure electrical continuity of bonding and grounding connections, and to demonstrate compliance with specified maximum grounding resistance. Refer to NFPA70B, Chapter 18, for testing and test methods.
  - 1. Visual and mechanical inspection:
    - a. Visually inspect all rack support hardware, cable runway, runway support hardware, splice connectors and structural supports for loose bolts, nuts and other connection hardware that could cause the mechanical failure of cable support systems.
    - b. Inspect ground connections to conduits, cable runway, equipment racks, BEP's, backbone cables and bus bars for mechanical integrity of the bond between ground cable and grounded equipment.
    - c. Inspect the ground bus between electrical ground and each bus bar in system.
  - 2. Test values:
- C. In the event that the system fails to function properly during the testing as a result of inadequate pretesting or preparation, the Contractor shall bear all costs incurred by the necessity for retesting including test equipment, transportation, subsistence and the Engineer's hourly rate.
- D. Contractor shall replace at no costs to the Owner, all equipment and devices which are found defective or do not operate within factory specified tolerances.
- E. Contractor shall submit final report for review prior to Project closeout and final acceptance by the Owner. Test report shall indicate test dates, devices tested, results, observation, deficiencies and remedies. Test report shall be included in the operation and maintenance manuals.

### 3.10 CLEANING

- A. Upon completion of Project prior to final acceptance the Contractor shall thoroughly clean all equipment per Manufacturers approved methods and materials. Remove paint splatters and other spots, dirt and debris.
- B. Touch-up paint any marks, blemishes or other finish damage suffered during installation.

**END OF SECTION 27 11 00**

**SECTION 27 15 00 - COMMUNICATIONS HORIZONTAL CABLING**

**PART 1 - GENERAL**

**1.1 SUMMARY**

- A. Work included: Labor, materials and equipment necessary to complete the installation required for the item specified under this Division, including but not limited to:
1. Horizontal twisted pair cabling.
  2. Telecommunication testing.
- B. Related Work: Consult all other Sections, determine the extent and character of related Work and properly coordinate Work specified herein with that specified elsewhere to produce a complete installation.

<u>SECTION NO.</u>	<u>SECTION TITLE</u>
27 00 10	BASIC COMMUNICATIONS REQUIREMENTS
27 05 29	COMMUNICATIONS HANGERS AND SUPPORTS
27 05 53	COMMUNICATIONS IDENTIFICATION
27 11 00	COMMUNICATIONS EQUIPMENT ROOMS
27 51 23	PUBLIC ADDRESS/INTERCOM SYSTEM

**1.2 REFERENCES**

- A. Comply with the latest edition of the following applicable Specifications and standards except as otherwise indicated or specified:
1. Federal Communications Commission (FCC) Regulations:  
FCC Part 15; Radio Frequency Devices & Radiation Limits.  
FCC Part 68; Connection of Terminal Equipment to the Telephone Network.
  2. Electronics Industries Alliance (EIA):  
EIA; Testing Standards.
  3. American National Standards Institute, Inc. (ANSI) / Telecommunications Industry Association (TIA) / Electronics Industries Alliance (EIA):  
ANSI/TIA/EIA-568-C; Commercial Building Telecommunications Cabling Standards, including the following:
    - Part 1: General Requirements.
    - Part 2: Balanced Twisted-Pair Cabling Components.
    - Part 2, Addendum 1: Transmission Performance Specifications for 4-Pair 100 Ohm Category 6 Cable.
    - TIA SP 3-4426 (12/28/06 or latest version): Transmission Performance Specifications for 4-Pair 100 Ohm Augmented Category 6 Cable (to be published as TIA-568-C.2-10).ANSI/TIA/EIA-569-A; Commercial Building Standard for Telecommunications Pathways and Spaces, including the following:
    - TIA/EIA-569-A-1: Perimeter Pathway Addendum.
    - TIA/EIA-569-A-2: Furniture Pathway Fill Addendum.
    - TIA/EIA-569-A-3: Access Floors.

- TIA/EIA-569-A-4: Poke-Thru Devices.
  - TIA/EIA-569-A-6: Multi-Tenant Pathway and Spaces.
  - TIA/EIA-569-A-7: Cable Trays and Wireways.
  - ANSI/TIA/EIA-598-B; Optical Fiber Cable Color Coding.
  - ANSI/TIA/EIA-606-A; Administration Standard for Commercial Telecommunications Infrastructure.
  - ANSI/J-STD-607-A; Commercial Building Grounding (Earthing) and Bonding Requirements for Telecommunications.
  - ANSI/TIA/EIA-758; Customer-Owner Outside Plant Telecommunications Cabling Standard (TIA/EIA-758-1: Addendum No. 1).
  - TIA TSB-155; Guidelines for the Assessment and Mitigation of Installed Category 6 Cabling to Support 10GBase-T.
4. Building Industry Consulting Service International, Inc. (BICSI):
- BICSI (TDMM); Telecommunication Distribution Methods Manual.
  - BICSI; Customer-Owner Outside Plant Design Manual.
  - BICSI (WDRM); Wireless Design Reference Manual.
  - BICSI (NDRM); Network Design Reference Manual.
5. Insulated Cable Engineers Association (ICEA):
- ICEA S-80-576-2002; Category 1 & 2 Individually Unshielded Twisted Pair Indoor Cables for Use in Communications Wiring Systems.
  - ICEA S-83-596-1994; Fiber Optic Premises Distribution Cable.
  - ICEA S-87-640-1999; Fiber Optic Outside Plant Communications Cable.
  - ICEA S-90-661-2002; Category 3, 5 & 6 Individually Unshielded Twisted Pair Indoor Cable for Use in General Purpose and LAN Communication Wiring Systems.
  - ICEA S-104-696-2001; Standard for Indoor-Outdoor Optical Cable.
6. Underwriters Laboratories, Inc. (UL):
- UL 444; Communication Cables.
  - UL 497; Protectors for Paired-Conductor Communication Circuits.
  - UL 1651; Optical Fiber Cable.
  - UL 1690; Data-Processing Cable.
  - UL 1963; Communications-Circuit Accessories.
  - UL 2024A; Optical Fiber Cable Routing Assemblies.

### 1.3 DEFINITIONS

- A. Above finish floor (AFF) - Standard mounting height (e.g., 18 inch AFF) for a device using the center line of the device as the measurement point.
- B. Administration - The methodology defining the documentation requirements of a cabling system and its containment, the labeling of functional elements and the process by which moves, additions, and changes are recorded.



- C. ANSI/TIA/EIA - Associations involved in developing telecommunications industry standards.
- D. Attenuation - The decrease in magnitude of transmission signal strength between points, expressed in dB as the ratio of output to input signal level.
- E. Attenuation-to-crosstalk ratio (ACR) - The ratio obtained by subtracting insertion loss (attenuation [dB]) from near-end crosstalk (dB). ACR is normally stated at a give frequency.
- F. Auditory assistance device - An intentional radiator used to provide auditory assistance to a handicapped person or persons. Such a device may be used for auricular training in an educational institution, for auditory assistance at places of public gatherings, such as a church, theater, or auditorium, and for auditory assistance to handicapped individuals, only, in other locations.
- G. Backboard - Backboard generally refers to the 3/4" A-C grade plywood sheeting, lining the walls of the telecommunications room. Plywood shall be void-free, with two coats of fire retardant paint matching the painted interior walls covering both sides.
- H. Backbone - A facility (e.g., pathway, cable, or conductors) between any of the following spaces: telecommunications rooms, common telecommunications rooms, floor-serving terminals, entrance facilities, equipment rooms, and common equipment rooms.
- I. Basic link test configuration - Horizontal cable of up to 90m (295 ft) plus up to 2m (6.5 ft) of test equipment cord from the main unit of the tester to the local connection, and up to 2m (6.5 ft) of test equipment cord from the remote connection to the remote unit of the tester. Maximum length is 94 m (308 ft).
- J. Bonding Conductor (BC) - A conductor used specifically for the purpose of bonding.
- K. Cable Labeling System –
  - 1. The scheme employed when identifying cable or its associated hardware.
  - 2. Scheme adapted for labeling cables to identify them based on ANSI/TIA/ EIA-606-A, Administration Standard for Commercial Telecommunications Infrastructure. See administration.
- L. Cable Runway - Hardware designed and manufactured for horizontal pathway distribution of cable and inside wiring inside the MC, IC, or TR rooms.
- M. CAT - Category used when identifying the performance characteristics of twisted pair cabling.
- N. Ceiling Distribution System - A distribution system that utilizes the space between a suspended or false ceiling and the structural surface above.
- O. Closed-Circuit Television (CCTV) - A private television system, typically used for security purposes, in which the signal is transmitted to a limited number of receivers.
- P. Communications plenum cable (CMP) - Type CMP communications plenum cable shall be listed as being suitable for use in ducts, plenums, and other spaces used for environmental air and shall also be listed as having adequate fire-resistant and low smoke-producing characteristics. (NEC)Cables must pass required test for fire and smoke characteristics of wires and cables, NFPA 262 or UL 910.
- Q. Communications Riser Cable (CMR) - Type CMR communications riser cable shall be listed as being suitable for use in a vertical run in a shaft or from floor to floor and shall also be listed as having fire-resistant characteristics capable of preventing the carrying of fire from floor to floor. (NEC) Cables must pass requirements for flame propagation.

- R. Electromagnetic Interference (EMI) - Radiated or conducted electromagnetic energy that has an undesirable effect on electronic equipment or signal transmissions.
- S. Entrance Conduit - Conduit that connects the campus underground infrastructure with the building's Telecommunications Room.
- T. Fire Retardant - Any substance added to delay the start or ignition of fire or slow the spread of the flame of any material.
- U. Firestopping - The process of installing [specialty] listed fire-rated materials into penetrations of fire-rated barriers to reestablish the fire-resistance rating of the barrier.
- V. Firestopping Location. A penetration through a fire-rated wall with a sleeve.
- W. Firestop System - A specific installation consisting of the material(s) (firestop penetration seals) that fill the opening in the wall or floor assembly, and around and between any items that penetrate the wall or floor (e.g., cables, cable trays, conduit, ducts, pipes), and any termination devices (e.g., electrical outlet boxes) along with their means of support.
- X. Grounding Conductor - A conductor used to connect the grounding electrode to the buildings main grounding busbar.
- Y. Grounding System - A system of hardware and wiring that provides an electrical path from a specified location to an earth ground point.
- Z. Horizontal Cabling - The part of the cabling system that extends from the work area telecommunications outlet to the horizontal cross-connect in the telecommunications room.
- AA. Hybrid Cable - An assembly of two or more cables, of the same or different types or categories, covered by one overall sheath.
- BB. Infrastructure (Telecommunications) - A collection of those telecommunications components, excluding equipment, that together provide the basic support for the distribution of all information within a building or campus.
- CC. Intermediate Cross-connect (IC) - the connection point between a backbone cable that extends from the main cross-connect and the backbone cable from the horizontal cross-connect.
- DD. Loose Tube - A type of optical fiber cable construction where one or more fibers are laid loosely in a tube. Also called loose tube fiber.
- EE. Main Cross-connect (MC) - The cross-connect normally located in the Telecommunications Equipment Room for cross-connection and interconnection of entrance cables, first-level backbone cables, and equipment cables.
- FF. Metropolitan Area Network (MAN) - A data communications network that covers an area larger than a campus area and smaller than a wide area network. Typically interconnects two or more LANs and usually covers an entire metropolitan area.
- GG. MPOE - Minimum Point of Entry, Utility Partnerships/Alternate Carrier, usually located within the Telecommunications Room.
- HH. Multimode Fiber (MMF) - An optical fiber that carries many paths of light or an optical waveguide that allows many bound modes to propagate.

- II. Single-mode Fiber (SMF) - An optical fiber, usually step-index grade, which supports only one mode of light propagation. This does not necessarily imply single wavelength operation. The light source is normally a laser.
- JJ. Strand (STR) - A single unit of optical fiber within a cable (e.g., a 12-strand fiber cable has 12 individual optical fibers within the cable sheath).
- KK. Telecommunications Entrance Facility - Utility Partnerships/Alternate Carrier Minimum Point of Entry that is usually located within the Main Cross-connect Room (MC).
- LL. Telecommunications Equipment Room (TER) - A centralized space that provides space and maintains a suitable operating environment for the termination of backbone and campus cabling and house centralized communications and/ or computer equipment (such as Core Switches and Servers). *Note:* An equipment room is considered distinct from a telecommunications closet because of the nature or complexity of the equipment housed by the equipment room.
- MM. Telecommunications Main Grounding Busbar (TMGB) - A grounding busbar, located in the MC, connected to the main building ground electrode by a continuous 2/0 - #4 AWG wire (Wire size is dependant on the distance between the busbar and the building main).
- NN. Telecommunications Room (TR) – A room dedicated to housing a group of telecommunications connectors (e.g., patch panel or punch-down block) that allows equipment and backbone cabling to be cross connected with patch cords or jumpers.
- OO. Underwriters Laboratories (UL) - A United States-based independent testing laboratory that sets safety tests and standards.
- PP. Uninterruptible Power Supply (UPS) - A device that is inserted between a primary power source (e.g., a commercial utility) and the primary power input of equipment to be protected (e.g., a computer system) to eliminate the effects of transient variances or temporary outages. Retain acronyms, abbreviations, and terms that remain after this Section has been edited.

#### 1.4 SYSTEM DESCRIPTION

- A. Provide a complete telecommunication cabling system installation as specified herein and as shown on the Drawings. In general, system shall include, but not be limited to, the following:
  - 1. Horizontal twisted pair cabling:
    - a. Horizontal twisted pair cables shall route between the TR and workstation outlets, and shall consist of Category 6, 4-pair, UTP, plenum rated copper cables.
    - b. Horizontal twisted pair cable will support communication devices such as but not limited to the following:
      - 1) Data work stations
      - 2) Telephones
      - 3) Emergency Phones
      - 4) Fax Machines
      - 5) Wireless Access Points
      - 6) Projectors
      - 7) Projection Screens
      - 8) Intercom speakers
      - 9) Controllers
      - 10) AV equipment
      - 11) HVAC Equipment
      - 12) Security Cameras
      - 13) Security Alarm Panels

14) Fire Alarm Panels

- c. Horizontal twisted pair work station cables shall terminate on back of rack mounted, Category 6, 48-port, 19" patch panels with modular 8-pin connector front for interface with Owner furnished routers/switches via owner furnished owner installed Category 6 patch cords. Patch panels shall have 110 type terminations at rear for horizontal cable terminations.
- d. Horizontal twisted pair camera station cables shall terminate on back of rack mounted, Category 6, 24-port, 19" patch panels with modular 8-pin connector front for interface with Owner furnished routers/switches via owner furnished owner installed Category 6 patch cords. Patch panels shall have 110 type terminations at rear for horizontal cable terminations.
- e. Wire management shall be provided above and below each patch panel and shall be 2 RU.
- f. Category 6, RJ-45 connectors at all outlets.

2. Patch cords:

- a. Owner Furnished Owner Installed

B. Station Outlets

- 1. Standard telecommunication outlets shall consist of the following, unless otherwise noted on the Drawings:
  - a. Two horizontal twisted pair cable(s) per hard walled outlet.
  - b. 4 11/16" Square, 2-1/8" deep box, with single gang ring and 1" Conduit to accessible ceiling, and single -gang cover plate with 4 ports.
  - c. Two RJ-45 connector jacks, for twisted pair terminations.
  - d. Blanks as required.
- 2. Standard telecommunication outlets shall consist of the following, unless otherwise noted on the Drawings:
  - a. Two horizontal twisted pair cable(s) per cubical office outlet.
  - b. 4 11/16" Square, 2-1/8" deep box, with single gang ring and 1.25" conduit to accessible ceiling, single -gang cover plate with 4 ports.
  - c. Two RJ-45 connector jacks, for twisted pair terminations.
  - d. Blanks as required.

C. Wireless Access Point and Camera Outlets (Cat 6)

- 1. WAP telecommunication outlets shall consist of the following, unless otherwise noted on the Drawings:
  - a. One horizontal twisted pair category 6 cable per outlet.
  - b. Single -gang cover plate with 2-ports when wall mounted.
  - c. Surface mount box with 2-ports when above accessible ceiling.
  - d. One RJ-45 connector jack, for twisted pair terminations.
- 2. Blanks as required.
- 3. Surveillance Camera Outlets (Cat 6)
  - a. Camera telecommunication outlets shall consist of the following, unless otherwise noted on the Drawings:

- b. One horizontal twisted pair cable(s) cat 6 per outlet.
- c. 4 11/16" Square, 2-1/8" deep box, with single gang ring and single -gang cover plate with 2 ports.
- d. One RJ-45 connector jack, for twisted pair terminations.
- e. Blanks as required.

D. Wall Mounted Telephone outlets (Cat 6)

- 1. Wall mounted telephone outlets shall consist of the following, unless otherwise noted on the Drawings:
  - a. One horizontal twisted pair cable per outlet.
  - b. Single-gang metal cover plate with 1-port and two support studs.
  - c. One RJ-45 connector jack for twisted pair terminations.

E. Building Automation System (BAS)

- 1. Control Panel Location
  - a. One horizontal twisted pair cable(s) cat 6 per outlet.
  - b. Surface mount box with 2-ports.
  - c. One RJ-45 connector jack, for twisted pair terminations.

F. Refer to Drawings for complete documentation of above requirements and all additional requirements.

1.5 SUBMITTALS

A. Submit in accordance with the requirements of Section 27 00 10: Basic Communications Requirements, the following items:

- 1. Data/catalog cuts for each product and component specified herein, listing all physical and electrical characteristics and ratings indicating compliance with all listed standards.
- 2. Describe system operation, equipment, dimensions and indicate features of each component.
- 3. Clearly mark on each data sheet the specific item(s) being submitted and the proposed application.
- 4. Shop Drawings prepare in AutoCAD Release 2016, to include the following:
  - a. Building floor plans showing location of all outlets, raceways, cable trays, conduits and cable routing to each device at same scale as construction documents.
  - b. Provide 1/4" scale plans of equipment layout in MPOE, IC and TR rooms.
  - c. Provide wall elevations of MPOE, IC and TR rooms at 1/2" scale.
  - d. Provide equipment rack elevations at 1/2" scale.
  - e. Use identical symbols as those used in construction documents.
  - f. Text shall be a minimum of 3/32" high when plotted at full scale.
  - g. Screen all background information.
- 5. Furnish structural calculations for equipment anchorage as described in Section 27 00 10: Basic Communications Requirements.
- 6. Complete bill of materials listing all components.

1.6 WARRANTY.

- A. Installer's qualifications: Furnish satisfactory proof of required experience specified herein for system installer.

1. The installing contractor shall be certified by the manufacturer for the product installed to provide a manufacturer's product and application warranty.
2. Technicians shall be certified by the manufacturer of the system components installed per the manufacturer's requirements to provide a certified structured cabling system. The structured cable system shall be warranted by Leviton Corporation with a Life Time Warranty. The warranty certification shall be provided to the owner at the completion of the project. All required drawings and test results shall be provided to the manufacturer by the contractor as required by the manufacturer to provide the manufacturer's warranty.

1.7 RECORD DRAWINGS:

- A. Furnish Record Drawings as described in Section 27 00 10: Basic Communications Requirements, utilizing Shop-Drawing submissions with updated field conditions. These Drawings shall include but not be limited to the following:

1. Plot plans and building floor plans, showing point-to-point wiring location of all devices.
2. Block Diagram/Riser Diagram showing the system components and all conduit and wire type/sizes between each.

- B. Drawings shall be incorporated into the Record Drawing submission.

- C. Final acceptance will not be made until the Engineer has approved the Record Drawings.

1.8 OPERATION AND MAINTENANCE MANUAL

- A. Supply operation and maintenance manuals in accordance with the requirements of Section 27 00 10: Basic Communications Requirements, to include the following:

1. A detailed explanation of the operation of the system.
2. Pictorial parts list and part numbers.
3. Schematic wiring diagrams.
4. Telephone numbers for the authorized parts and service distributor.
5. Final testing reports.

1.9 QUALITY ASSURANCE

- A. All materials, equipment and parts comprising the units specified herein shall be new, unused and currently under production.

- B. Only products and applications listed in this section may be used on the Project unless otherwise submitted.

- C. Manufacturer qualifications: Manufacturer must have a minimum 5 continuous years of experience in design and manufacturing of the materials and equipment specified herein.

- D. Installer's qualifications:

1. Installer must have a minimum 5 continuous years of experience in satisfactory completion for Projects similar in scope and cost. Provide backup information on 5 such Projects.
2. Installer shall possess a current, active and valid C7 or C10 California State Contractors License.
3. The installer shall be the Manufacturer's certified reseller/installer of the telecommunication equipment/cable system provided. The certification shall have been completed 60 days prior to project bid date. Provide evidence of this certification.

1.10 PRODUCT DELIVERY, STORAGE AND HANDLING

- A. Delivery: Telecommunication system components shall not be delivered to the Project site until protected storage space is available. Storage outdoors covered by rainproof material is not acceptable. Equipment damaged during shipping shall be replaced and returned to Manufacturer at no cost to Owner.
- B. Storage: Store in clean, dry, ventilated space free from temperature extremes. Maintain factory wrapping or provide a heavy canvas/plastic cover to protect units from dirt, water, construction debris and traffic.
- C. Handling: Handle in accordance with Manufacturer's written instructions. Be careful to prevent internal components damage, breakage, denting and scoring. Damaged units shall not be installed. Replace damaged units and return equipment to Manufacturer.

1.11 WARRANTY

- A. Units and components offered under this Section shall be covered by a Life Time product and application warranty for malfunctions resulting from defects in materials and workmanship. Warranty shall be provided from the component manufacturer and shall name the owner on the warranty certificate. Warranty shall begin upon acceptance by the Owner.
- B. Contractor shall provide required drawings, test results, application and any other items required by the manufacturer to produce the required warranty.

1.12 MAINTENANCE

- A. Maintenance services:
  - 1. Distributor of the major system components shall maintain a replacement parts department and provide testing equipment when needed. A complete parts department shall be located close enough to supply replacement parts within a 4 hour period.
  - 2. Service must be rendered within 4 hours of system failure notification.

PART 2 - PRODUCTS

2.1 MANUFACTURERS

- A. Products furnished by the following Manufacturers shall be in compliance with all features specified herein and indicated on the Drawings.
  - 1. Horizontal Structured Cable Systems
    - a. Leviton/BerkTek (No substitutions accepted)
  - 2. Horizontal twisted pair cable:
    - a. BerkTek (No substitutions accepted)
  - 3. Horizontal Termination Devices
    - a. Leviton (No substitutions accepted)
  - 4. Horizontal wire managers
    - a. Leviton (No substitutions accepted)

5. Test equipment:
  - a. Fluke Networks.
  - b. Agilent Technologies
  - c. Tektronix.
- B. Substitutions: Components specified are per the owners component standards for Structured cabling systems and substitutions will not be accepted.

## 2.2 HORIZONTAL TWISTED PAIR CABLING

- A. Horizontal cables:
  1. Application:
    - a. Suitable for indoor installations, exposed within equipment rooms, above suspended ceilings and below raised floors in cable trays, hangers or on deck, or within walls. If space is used as an air plenum, cable shall either be plenum rated or installed in EMT conduit.
    - b. Each cable run shall be continuous single cable, homogenous in nature, without splices.
    - c. Cables shall meet CAT 6e performance criteria for all applications.
    - d. Cables shall be CMP rated as required for rating of space..
  2. Conductors:
    - a. Insulated conductors: Eight #23\_AWG, solid copper wire insulated with FEP for plenum applications or thermoplastic polyethylene or high-density polyolefin for non-plenum rated applications.
    - b. Twisted pairs: Two insulated conductors twisted together to form a pair and four such paired cables to form a unit with individually color-coded pairs to conform to industry standards (ANSI/ICEA Publication S-80-576-1994 and EIA-230).
  3. Cable sheath:
    - a. Outer jacket: Seamless outer jacket, flame-retardant PVC, applied to and completely covering the internal components (twisted pairs).
    - b. Flame rating: CMP according to NEC Article 800, tested to NFPA 262 and UL Listed as such.
  4. Electrical performance: Meet or exceed TIA/EIA-568-C.2 Enhanced and ISO 11801 Class E specifications for CAT6e UTP cabling.
  5. Manufacturer:
    - a. Cat 6: BerkTek Lanmark 1000
      - 1) Part #:
        - a) Plenum (CMP) #11074694

## 2.3 COPPER DISRIBUTION PATCH PANELS

- A. Application: To terminate horizontal distribution cable for data and telephone systems. The patch panels shall match the category of the horizontal cable and be from the same cable manufacturer or matched to the cable manufacturer for maximum warranty as required by the manufacturer.



1. Copper patch panels shall be 19" rack mountable 48 ports per rack mounting unit and shall be no more than two rack mounting units in height.
2. All copper patch panels for Cat 5e cable shall have IDC-type terminating blocks. Provide Flat QuickPort patch panels for Category 6 . Refer to 2.04.b
3. There shall be port identifier label space on the front and shall also include a port identifying number.
4. Manufacturer:
  - a. Leviton
  - b. Part #:
    - 1) Category 6, 48 port Patch Panel: #49255-H48.
    - 2) Category 6, 24 port Patch Panel: #49255-H24.

#### 2.4 WORKSTATION JACKS AND WALLPLATES

- A. Outlet faceplates shall be suitable for indoor installations to standard single or double-gang flush wall mounted outlet box plaster rings, and floor boxes.
- B. Outlets:
  1. Data Jacks shall be 8 pin, 110/IDC termination and rated Category 6.
  2. Manufacturer: Leviton
  3. Part #:
    - a. Standard Cat 6 Data Jack: #61110-RY6 (Yellow)
  4. Standard wall mounted faceplates:
    - a. Voice/Data outlets will be of modular design, color-coded to distinguish between data service and Wireless data service. Each outlet shall be configured with Modular 8-Pin jacks wired to the T568B pin assignment sequence.
    - b. All outlet jacks will be rated for category 6 systems. Data jacks will be Yellow. All wall face plates will be stainless steel and have 2 or 3 ports with Identification windows.
    - c. All unused ports will be filled with a blank insert to match the color of the plate.
    - d. Manufacturer: Leviton
      - 1) Part #: 2 port Wall Plate: #43080-1S2
      - 2) Part #: 3 port Wall Plate: #43080-1S3
  5. Surface mounted outlet boxes
    - a. Surface outlets shall be fully compatible with the specified modular connector/jacks.
    - b. Surface mount boxes shall have breakouts to accomodate surface mount raceway and cable entry. Boxes shall be a 2 piece design with a minimum 2 jack configuration.
    - c. Outlets can be secured with screws, adhesive or mounting magnets.
    - d. Outlet box shall have a ID window with plastic cover.
    - e. Manufacturer: Leviton
      - 1) Part #: Wall Plate: #41089-2WP
  6. Above Ceiling Outlets
    - a. Leviton: Quick Port Ceiling Bracket

1) #49223-CBC

7. Wall mounted phone faceplates:
    - a. Faceplate shall be single-gang, flush mounted with 1 recessed port and shall include required accessories.
    - b. Faceplate shall include two mounting studs for standard wall phone instrument.
    - c. Faceplate shall be stainless steel.
    - d. Manufacturer: Leviton
    - e. Part #: Wall Plate: #4108W-1SP
  8. Partition furniture mounted faceplates:
    - a. Faceplates shall have 4-ports and shall include required accessories, such as icons, blank inserts, label windows and labels.
    - b. Furniture plate shall match the type furniture installed for a seamless snap in fit to the base knock out of the installed furniture.
    - c. Faceplates shall match the color of the furniture base.
    - d. Manufacturer: Leviton
    - e. Part #: Furniture Plate: #49910-Sx4 (x=Color)
- C. Horizontal cable management: 2RU horizontal cable manager.
1. Leviton
  2. Part #492RU-HFR
- D. Labels:
1. Labels shall be machine printable with a laser printer, ink jet printer, thermal transfer printer or hand-held printer.
  2. Labels for horizontal cables:
    - a. Adhesive backed labels and self-laminating feature.
    - b. Fit the horizontal cables specified herein by fully wrapping around the cable jacket.
    - c. Size: 2" x .05" printable area, minimum.
    - d. Color: White.
- E. Miscellaneous components:
1. Velcro cable ties:
    - a. Width: 0.75".
    - b. Color: Velcro cable ties the same color as the cable to which it is applied.
  2. Plenum cable ties:
    - a. Suitable for use in plenums or air handling spaces.
    - b. Color: Maroon or other distinctive non-white color.

## 2.5 CABLE TESTING EQUIPMENT

- A. Twisted pair cabling:
1. Horizontal cable tester:
    - a. Equipment shall meet TIA/EIA-568C.2 Addendum 1 requirements for Level III accuracy, as applicable for cable type specified herein.

- b. Test standards: ISO/IEC 11801 Class C and D; ISO/IEC 11801-2000 Class C and D, 1000Base-Y, 100Base-TX; IEEE 802.3 10Base-T; ANSI TP-PMD; IEEE 802.5.
- c. Areas of test measurement (minimum):
  - 1) Wire Map.
  - 2) Length.
  - 3) Insertion Loss.
  - 4) The following at both master unit and remote unit:
    - a) Near End Crosstalk (NEXT) loss.
    - b) Power Sum NEXT (PSNEXT) loss.
    - c) Equal Level Far End Crosstalk (ELFEXT).
    - d) Power Sum ELFEXT.
    - e) Return Loss (RL).
    - f) Attenuation-to-Crosstalk Ratio (ACR).
    - g) Power Sum ACR (PSACR).
  - 5) Propagation Delay and Delay Skew.
  - 6) Characteristic Impedance.
  - 7) DC Loop Resistance.

### PART 3 - EXECUTION

#### 3.1 EXAMINATION

- A. Contractor shall thoroughly examine Project site conditions for acceptance of the telecommunication cabling system installation to verify conformance with manufacturer and specification tolerances. Do not commence with installation until all conditions are made satisfactory.
- B. Verify that pathways and supporting devices are properly and completely installed prior to cable installation.
- C. Verify dimensions of pathways to include length, i.e. "true tape" conduit runs.
- D. Prior to installation, verify that equipment rooms are ready to accept cables and terminations.

#### 3.2 INSTALLATION

- A. Horizontal management panels:
  - 1. Provide the horizontal management panels mounted to racks with one above each patch panel and one below the bottom patch panel in each rack bay where patch panels occur.
  - 2. Provide fasteners and parts required to complete the installation.
- B. Accessories: Provide all accessories as required for a complete installation. Include one bag of rack mounting screws, as come packaged with rack product. Attach the screws directly to the rack, which shall constitute turn-over to the Owner.
- C. Horizontal twisted pair cabling:
  - 1. Horizontal cable installation and routing:
    - a. Cable runs shall have continuous sheath continuity, homogenous in nature with no splicing.

- b. No cabling shall exceed a cable length of 295' (90m) from the termination point at the equipment room to the termination at the workstation outlet, including service slack, when measured using test equipment.
  - c. Place cables within the designated pathways, such as cable tray or basket tray, cable runway, cable hangers, etc. Do not fasten, support or attach cables to other building infrastructures (i.e. ducts, pipes, conduits, etc.), other systems (i.e. ceiling support wires, wall studs, etc.), or to the outside of conduits, cable trays and nonapproved pathway systems.
  - d. Place and suspend cables during installation and termination in a manner to protect them from physical damage or interference. Place cables with no kinks, twists, or impact damage to the sheath. Replace cables damaged during installation or termination at no additional cost.
  - e. Route cables at 90° angles, allowing for bending radius.
  - f. Do not exceed pulling tension of 25 lbs.
  - g. Do not use cable-pulling compounds.
  - h. Do not exceed a minimum bend radius of 6 times the cable diameter during and after installation.
  - i. Route cables beneath other building infrastructures (i.e. ducts, pipes, conduits, etc.) in above ceiling applications. Do not route cables over building infrastructures. The installation shall result in easy accessibility to the cables in the future.
  - j. Place cables 6" minimum away from power sources to reduce interference from EMI.
  - k. Do not set 360° service loops in place for slack storage. Instead, set slack as forward-and-back or as figure eights.
  - l. Place a pull string along with cables where run in conduits and spare capacity in conduit remains. Tie off ends of the pull string to prevent the string from falling onto the conduit.
  - m. When exiting the primary pathway, such as cable or basket tray, to the workstation outlets, exit via the top of the pathway. Secure the cables to the pathway using an approved cable tie.
2. Cable routing and dressing within equipment rooms:
- a. Within equipment rooms, only use Velcro type straps.
  - b. Place cables within the overhead cable support system. When routing vertically on walls, fasten the cables onto vertical supports every 24" on center.
  - c. Provide 12" minimum sheath cable slack, length not to exceed permanent link maximum length requirement. Place the slack in the overhead cable support system.
  - d. At the rack bay, route and neatly dress cables from the overhead cable support system into the back of the vertical management sections. Divide the cables equally between both sides of an equipment rack such that a cable does not travel past the midpoint of the rack prior to termination. Fasten the cables to the cable support bar at the back of the patch panel using approved ties.
3. Termination in the equipment rooms:
- a. Provide termination apparatus and accessories required for a complete installation. Install and assemble termination apparatus, accessories and associated management apparatus according to the manufacturer's instructions.
  - b. Properly relieve strain from the cables to and at termination points per manufacturer's instructions. Provide a strain relief bar at the back of the modular patch panels for proper strain relief.
  - c. Terminate cables and twisted pairs in accordance with manufacturer's latest installation requirements and TIA/EIA-568-C standard installation practices. Terminate cable pairs onto the termination apparatus compliant to T568B wiring.
  - d. Modular patch panels and horizontal management panels:

- 1) Provide quantity of modular patch panels to support the terminations of cables served from respective Telecom Room. Provide quantity of horizontal management panels based on the quantity of patch panels.
  - 2) Install and assemble modular patch panels and horizontal management panels according to the manufacturer's instructions.
  - 3) Install the patch panels and the horizontal management panels as shown on the Drawings.
  - 4) Terminate cables in sequential order using the link's identifier starting at the top left and completing a panel before moving to the next panel below.
4. Cable routing and dressing at workstations:
- a. Provide 18" cable slack at each workstation outlet, length not to exceed permanent link maximum length requirement. Place the slack within ceiling space neatly on a cable hanger or other approved cable support device.
  - b. Route to partition furniture mounted faceplates:
    - 1) Route cables from primary or secondary pathway within ceiling through the furniture partition feed pathway (stub from wall or floor box) into opening at bottom of furniture system. Exercise caution to prevent scraping, cutting or other damage to cable jacket.
    - 2) Provide spiral wrap around cables from furniture-feed pathway to point where cables enter furniture.
5. Termination at the workstation outlets:
- a. Provide device components, connectors, and accessories required for a complete installation. Install and assemble connectors, jacks, adapters, termination apparatus, accessories and associated management apparatus according to the manufacturer's instructions.
  - b. Provide orange connectors for data links and green connectors for wireless data.
  - c. Wall mounted standard devices:
    - 1) Install devices at heights indicated on drawings.
    - 2) Mount faceplates plumb, square and at the same level as adjacent power receptacles.
    - 3) Patch gaps around faceplates so that faceplate covers the entire wall opening.
  - d. Partition furniture mounted devices:
    - 1) Coordinate installation of the faceplate adapters with the furniture contractor, including color.
    - 2) Mount faceplate adapters into the designated openings for horizontal cables.
  - e. Terminate cables and twisted pairs in accordance with the manufacturer's latest installation requirements and TIA/EIA-568-B standard installation practices. Terminate cable pairs onto the connector compliant to T568B wiring.

### 3.3 LABELING

#### A. General requirements:

1. Labeling, label colors, and identifier assignments shall conform to EIA/EIA-606-A Administration Standards and as approved by the Owner.

2. Provide permanent and machine-generated labels. Hand written labels will not be accepted.
  3. Modular patch panels:
    - a. Text color shall be black, #10 font size.
    - b. Label installation:
      - 1) Provide labels at each port.
      - 2) Install labels into label window.
- B. Horizontal twisted pair labeling:
1. Cables:
    - a. Text color shall be black, #10 font size.
    - b. Label installation:
      - 1) Provide labels on both ends of cable.
      - 2) Install labels such that they are visible by technician from a normal stance.
      - 3) Fully wrap label around the cable jacket (self lamination).
      - 4) Provide one label within 4" of the termination apparatus.
  2. Modular patch panels:
    - a. Text color shall be black, #10 font size.
    - b. Label installation:
      - 1) Provide labels at each port.
      - 2) Install labels into label window.
  3. Outlets:
    - a. Text color shall be black, #10 font size.
    - b. Label installation:
      - 1) At faceplates, provide labels above and below jacks.
      - 2) At surface boxes, provide labels on the top of the box.
- C. General:
1. Calibrate test sets and associated equipment per the manufacturer's instructions at the beginning of each day's testing and after each battery charge. Fully charge the test sets prior to each day's testing to ensure proper operation.
  2. Ensure test equipment and test cords are clean and undamaged during testing activities. Per the Engineer's discretion, halt testing activity and clean testing equipment, test cords and related apparatus.
  3. Permanently record test results electronically within test equipment at the time of testing.
- D. Twisted pair testing:
1. Test for UTP cabling as follows:

TESTS FOR CATEGORY 6 CABLING TABLE				
Subsystem	Type	Test	Configuration	Notes
Horizontal	CAT6, CAT6A	Category 6, & 6A	Permanent Link	Per TIA/EIA-568-C.2

2. Precautions:
  - a. Adhere to the equipment manufacturer's instructions during all testing.
  - b. Prior to any testing activity or any measurements taken, ensure the test equipment is at room temperature, approximately 70°F.
  - c. Fully charge power sources before each day's testing activity.
  
3. Horizontal twisted pair testing:
  - a. Test equipment set-up:
    - 1) Set-up the tester to perform a full CAT6/Cat 6A test, as a Permanent Link configuration.
    - 2) If the tester has the capability, set the cable type as product specific setting. If not, set as generic CAT6, 6A cable.
    - 3) Set the tester to save the full test results (all test points, graphs, etc.).
    - 4) Save the test results with associated cable link identifier.
    - 5) Calibrate the test set per the manufacturer's instructions.
  
  - b. Acceptable test results measurements:
    - 1) Overall test results:
      - a) Links which report a Fail, Fail or Pass for any of the individual tests shall result in an overall link Fail. All individual test results must result in a Pass to achieve an overall Pass.
      - b) Any reconfiguration of link components required as a result of a test Fail, must be re-tested for conformance.
      - c) Remove and replace any cabling links failing to meet the criteria described in this Specification, at no cost to the Owner, with cables that prove to meet the minimum requirements.
  
    - 2) Wire map: Provide continuous pairs and terminate all of the cabling links correctly at both ends, no exceptions taken.
    - 3) Length: Ninety-four meters (308 feet) is the maximum acceptable electrical length measurements for any cabling link measured under a Permanent Link configuration, including test cords.
    - 4) Insertion loss: The acceptable insertion loss measurements for any horizontal cabling link is that which is no greater than that listed in TIA/EIA-568-C.2.
    - 5) Worst pair-to-pair near end crosstalk (NEXT) loss: The acceptable worst pair-to-pair NEXT loss for any horizontal cable is that which is no greater than that listed in TIA/EIA-568-C.2.
    - 6) Power sum NEXT loss: The acceptable power sum PS-NEXT loss for any horizontal cable is that which is no greater than that listed in TIA/EIA-568-C.2.
    - 7) Worst pair-to-pair ELFEXT and FEXT loss: The acceptable worst pair-to-pair ELFEXT and FEXT loss for any horizontal cable is that which is no greater than that listed in TIA/EIA-568-C.2.

- 8) Power sum ELFEXT and FEXT loss: The acceptable PS-ELFEXT and PS-FEXT loss for any horizontal cable is that which is no greater than that listed in TIA/EIA-568-C.2.
- 9) Return loss: The acceptable return loss measurements for any horizontal cabling link is that which is no greater than that listed in TIA/EIA-568-C.2.
- 10) Propagation delay and delay skew: The acceptable propagation delay and delay skew measurements for any horizontal cabling link is that which is no greater than that listed in TIA/EIA-568-C.2.

E. Record documents:

1. Permanently record all test results.
2. Export test results' numerical values to a single Microsoft Excel spreadsheet.
3. Submit test results in a format acceptable to the Owner, Owner's Representative and the Engineer before system acceptance.
4. Cable, fiber and pair identifiers of the test reports shall match the identifiers as labeled in the field, i.e. use the same ID on the cable/termination label as what appears on the test report.
5. Measurements shall carry a precision through one significant decimal place, minimum.
6. Use feet for the units for measurements shown on the print of the test measurements.
7. Print report such that fiber strands of a given cabling link have matching axis scales. The "X" and the "Y" axis shall be the same from report-to-report.
8. The trace of the printed test report shall show the launch cord.
9. For each cabling link, include either a schematic graphic or a brief narrative accurately describing the test set-up. The description shall include test/launch cord (with length), expected events (connectors, slices, etc.) with expected distances, etc. This information will eliminate many questions the Engineer will have while reviewing the reports.
10. For each twisted pair horizontal cable test, report shall contain the following information:
  - a. Project name and address.
  - b. Test company's and Operator's name.
  - c. Date measurements were taken.
  - d. Test equipment type to include model and serial numbers.
  - e. Cable identification number and pair number.
  - f. Measurement results.
  - g. Pass/Fail

3.4 INSPECTION AND ADJUSTMENTS

- A. Contractor shall inspect all installed Work in conjunction with the General Contractor and develop a "punch list" for all items needing correction. Provide punch list to the Engineer prior to their final walk of Project.
- B. Punchlist work and the required remediation shall be performed prior to system final acceptance.
- C. Replace or repair work completed by others that was defaced or destroyed during the installation of the telecommunication cabling system by this contractor.
- D. Make changes to adjust the system to optimum operation for final use. Contractor is responsible for making changes to the system such that any defects in workmanship are correct and all cables and the associated termination hardware passes the minimum test requirements.

3.5 CLEANING

- A. Remove all unused, excess and left over products, to include debris, spills, and installation equipment.



- B. Leave finished work and adjacent surfaces in neat, clean conditions with no evidence of damage.
- C. Legally dispose of debris.
- D. Clean installed products in accordance with manufacturer's instructions prior to final punch list.

3.6 TRAINING

- A. At the completion of all Work, a period of not less than four (4) hours shall be allocated by the Contractor for instruction and training for the Owner Representative. The Cabling Contractor will need to describe how the cable from each cover plate is separated between different patch panels, how cross-connects are made and other basic cable plant management skills.
- B. Contractor shall schedule training with a minimum of 7 days advance notice.

**END OF SECTION 27 15 00**

**SECTION 27 51 23 - PUBLIC ADDRESS/INTERCOM SYSTEM**

**PART 1 - GENERAL**

**1.1 SUMMARY**

- A. Work included: Labor, materials and equipment necessary to complete the installation required for the item specified under this Division, including but not limited to:

- 1. IP Intercom/public address system.

- B. Related Work: Consult all other Sections, determine the extent and character of related Work and properly coordinate Work specified herein with that specified elsewhere to produce a complete installation.

<u>SECTION NO.</u>	<u>SECTION TITLE</u>
27 00 10	BASIC COMMUNICATIONS REQUIREMENTS
270529	COMMUNICATIONS HANGERS AND SUPPORTS
270553	COMMUNICATIONS IDENTIFICATION
271100	COMMUNICATIONS EQUIPMENT ROOMS
271500	COMMUNICATIONS HORIZONTAL CABLING

**1.2 REFERENCES**

- A. Comply with the latest edition of the following applicable Specifications and standards except as otherwise indicated or specified:

- 1. Underwriters Laboratories, Inc. (UL):
    - UL 13; Power-Limited Circuit Cables.
    - UL 50; Enclosures for Electrical Equipment.
    - UL 813; Commercial Audio Equipment.

**1.3 SYSTEM DESCRIPTION**

- A. SIP intercom system with IP Gateway and amplified speakers
- B. The system connects via a PoE network switch to the IP Gateway. The gateway shall have two analog outputs to amplified
- C. All speakers will be analog with built in amplifiers.
- D. Furnish all labor, project management, materials, tools, equipment and resources necessary for the installation of a new Intercom System as shown on the plans and as herein specified.
- E. It is the intent of these specifications and the accompanying plans that the Contractor furnishes and installs a system complete in every respect and ready to operate. All miscellaneous items and accessories required for such installation, whether or not each such item or accessory is shown on the plans or mentioned in these specifications, shall be furnished and installed.
- F. Furnish additional items not mentioned herein to meet requirements as specified without claim for additional payments. Items, may include hardware, rack panels, termination blocks etc., software and other devices that are required for installation.
- G. It shall be the responsibility of the contractor to examine the plans and specifications carefully before submitting his bid. Any questions or discrepancies discovered shall be brought to the attention of the Architect/Engineer, prior to bid, and resolved by way of addendum.

- H. Furnish and install all necessary equipment, including but not limited to back boxes, specialty boxes, speakers, wall plates, supports and enclosures.
- I. Furnish and install all necessary structured cabling as needed from speakers and other IP equipment, and provide for all network connectivity Cat6 cable, etc.) for distribution of the intercom system.
- J. Furnish all programming of the system (initial and final) and audio level adjustments (initial and final).
- K. All materials, equipment and apparatus provided shall be new and of the latest design or model offered for sale by the manufacturer.

#### 1.4 RELATED WORK

- A. It shall be the responsibility of this Contractor to coordinate the installation of equipment with the other contractors on site, the Architect, and the Owner.

#### 1.5 SUBMITTALS

- A. Submit in accordance with the requirements of Section 27 00 10: Basic Communications Requirements, the following items:
  - 1. Documentation on the network requirements that are needed for proper installation and distribution.
  - 2. Data/catalog cuts for each product and component specified herein, listing all physical and electrical characteristics and ratings indicating compliance with all listed standards.
  - 3. Describe system operation, equipment and dimensions and indicate features of each component and cross referenced with a Component Block Relationship Diagram.
  - 4. Clearly mark on each data sheet the specific item(s) being submitted and the proposed application.
  - 5. Shop Drawings to include:
    - a. Plot plans and building floor plans, showing location of and conduit routing to all devices.
    - b. Point-to-point wiring diagrams in block or riser format showing all components, conduit and wire types and sizes with cable legend.
    - c. Provide ¼" scale plan of equipment layout in main equipment room (MDF).
  - 6. Include elevations of equipment rack(s).
  - 7. Furnish structural calculations for equipment anchorage as described in Section 27 00 10: Basic Communications Requirements Submit Manufacturer's installation instructions.
  - 8. Complete Bill of Materials listing all components.
  - 9. Warranty.
- B. Installer's qualifications: Furnish satisfactory proof of required experience specified herein for system installer.
- C. A copy of the intercom contractor's valid state contractor's license (C7) and written confirmation from the factory that he is an authorized distributor/installer of the submitted equipment.
- D. The following information shall be submitted at the end of the project and included in O&M Manuals.:
  - 1. Copy of product data cut sheets as submitted for review as noted above.

2. Complete as-built drawings on scaled floor plans depicting the final location of all equipment, each device, and cable routing as installed.
3. Certificate of Completion identifying that the installation is complete, programming is complete, training of the Owner and appropriate staff is complete. Certificate shall be signed by the Contractor and the Owner, and dated.
4. The following information shall be submitted at the end of the project and provided during Owner training:

#### 1.6 QUALITY ASSURANCE

- A. All materials, equipment and parts comprising the units specified herein shall be new, unused and currently under production.
- B. Only products and applications listed in this Section may be used on the Project unless otherwise submitted.
- C. Installer's qualifications: Firms with a minimum of 5 years of successful installation experience with projects utilizing school communication systems similar to that of this Project.
- D. The system shall be approved for direct interconnection to the utility services under part 68 of FCC rules and regulations. Those systems that are not FCC approved or utilize an intermediary device for connection, will not be considered. Provide FCC registration number of system being proposed in equipment submittal.
- E. Underwriter's Laboratories under UL Standard 1459 shall list the communication system supplied. A copy of the UL listing card for the proposed system shall be included with the Contractor's submittal.

#### 1.7 PRODUCT DELIVERY, STORAGE AND HANDLING

- A. Delivery: School communication system components shall not be delivered to the Project site until protected storage space is available. Storage outdoors covered by rainproof material is not acceptable. Equipment damaged during shipping shall be replaced and returned to Manufacturer at no cost to Owner.
- B. Storage: Store in clean, dry, ventilated space free from temperature extremes. Maintain factory wrapping or provide a heavy canvas/plastic cover to protect units from dirt, water, construction debris and traffic. Provide heat where required to prevent condensation.
- C. Handling: Handle in accordance with Manufacturer's written instructions. Be careful to prevent internal component damage, breakage, denting and scoring. Damaged units shall not be installed. Replace damaged units and return equipment to Manufacturer.

#### 1.8 WARRANTY

- A. Units and components offered under this Section shall be covered by a 1 year parts and labor warranty for malfunctions resulting from defects in materials and workmanship. Warranty shall begin upon acceptance by the Owner.

#### 1.9 SYSTEM START-UP

- A. Upon completion of installation, a factory trained dealer service representative shall perform initial start-up of the school communication system. Sufficient time shall be allowed to properly check the system out and perform required minor adjustments before the Engineer's witnessed test shall begin.

## PART 2 - PRODUCTS

### 2.1 MANUFACTURERS

- A. Valcom or equal

### 2.2 SYSTEM DESCRIPTION

- A. Components of the IP Intercom System shall provide a complete system IP Based solution for a fully functioning Intercom System (IC) and Public Address System (PAS) for the project. System shall include software from a single manufacturer for complete control and monitoring of the system for a fully supported system. System shall be IP based and operate over the owners Local Area Network (LAN).
- B. Contractor shall provide all system programming for configuration and interfaces.
- C. System shall be capable of being configured and controlled remotely via Owner provided connectivity (e.g. via a smart phone, VPN, etc.).
- D. System shall include General Purpose Input and Output (GPIO) trigger points for interfacing to other systems including Emergency and Security Systems, to provide event driven configuration scenarios for the system.
- E. System shall provide opening tones and messages for announcements to speakers.
- F. All common area loudspeakers shall operate from a network switch. The loudspeakers shall be grouped in modular zones allowing maximum flexibility for paging area assignment.
- G. Server, Software and Operating System shall be provided and connected to a separate Owner LAN. Provide all necessary hardware for support of system software.

### 2.3 SYSTEM EQUIPMENT

- A. IP Gateway: The VIP-201A SIP Paging Gateway shall be used with the owners IP based telephone system. The unit shall provide SIP addressable groups and 1 analog output. The device shall control thousands of IP and/or analog speakers or provide interface to legacy paging systems. Connection to a SIP Server can be as individual SIP Stations (extensions) or as a SIP trunk. Station mode shall provide up to 8 SIP-addressable groups. Trunk mode shall accept up to 100 SIP phone numbers for grouping.
- B. Speakers: The ceiling flush mounted 8" (20.32 cm) amplified speaker, Model V-1020C, shall include a speaker, amplifier, volume control and round grille. The speaker assembly, amplifier module, housing and hardware shall be electrically and acoustically matched for a frequency response of 80 Hz to 15 kHz. The assembly shall be FCC part 68 Registered. The registration number shall be BAF917-69358-KX-N. The speaker element shall be cone type with 5 oz (142 g) ceramic magnet. Diameter of speaker cone shall be 8.0" (20.32 cm). Voice coil diameter shall be .75" (1.91 cm). Voice coil impedance shall be 45 ohms. The amplifier shall have a frequency response of 80 Hz to 15 kHz. Distortion shall be less than 1.5% at rated output of 1 watt RMS. Signal to noise ratio shall be -70 dB. The amplifier shall operate on a -24 Vdc nominal power supply. Operating current shall be 50 mA at -24 Vdc. Operating temperature shall be -4 to +131 °F (-20 to +55 °C). A screwdriver adjustable volume control shall be provided at the center of the grille. The externally accessible volume control shall make it possible to adjust volume level of speaker without removal of unit. The grille shall be constructed of steel, finished in semi-gloss white enamel. The V-9915M-5 Backbox and V-9914M-5 Support Bridge shall be constructed of steel and finished for rust prevention. The backbox shall be acoustically treated. Both the backbox and support bridge shall be available

separately in quantities of five (5) or assembled together singly as the V-9916M The maximum dimensions shall be: Speaker and Grille - 13.0 "Dia x 3.0 "D (33.02 cm x 7.62 cm). Backbox: 4.0 "H x 12.3 "Dia (10.16 cm x 31.242 cm). Support Bridge: 23.75 "H x 14.5 "W x 1.5 "D (60.325 cm x 36.83 cm x 3.81 cm). Weight shall be approximately: Speaker and Grille: 2.5 lbs (1.13 kg). Support Bridge: 1.0 lb (0.45 kg). Backbox 1.8 lbs (0.81 kg). Bridge and Backbox Assembly 2.5 lbs (1.13 kg).

- C. 24VDC Power Supply: The wall mountable switching power supply, model number VP-6124, shall be -24 VDC power supply capable of providing 6 amperes of current. The design of this regulated power supply shall use switching technology, shall provide auto recovery short circuit protection and shall feature three (3) individual class "B" outputs each capable of providing 1/3 of the supply's rated current. Additionally, the supply's design shall incorporate EMI filtering, a minimum 88.5% efficiency, a 3 second power up delay, a working input frequency range of 47 to 63 Hertz and an LED status indicator. The supply shall also feature +/- 2 % voltage regulation and over voltage protection. The supply shall be capable of operating within a temperature range of 0° to 50° C and a humidity range of 10% to 90% non-condensing. An optional battery backup system, models number VP-6124-UPS and VBB-1424, shall be available to integrate with the power supply. Maximum dimensions of the supply shall not exceed 10.3 "H x 5.92 "W x 2.5 "D (26.162 cm x 15.0368 cm x 6.35 cm). Approximate weigh shall be 5.0 lbs (2.25 kg).EXAMINATION
- D. Contractor shall thoroughly examine Project site conditions for acceptance of school communication system installation to verify conformance with Manufacturer and Specification tolerances. Do not commence with installation until all conditions are made satisfactory.

## 2.4 PREPARATION

- A. Supplying Contractor shall coordinate all necessary service requests with the local utility and act as the agent for the Owner.
- B. Coordinate with Owner for quantity of incoming lines required.
- C. Coordinate with serving Telephone Company the installation and wiring of RJ31X blocks. These are required for fire alarm signaling, for security signaling and for campus energy management system.

## 2.5 INSTALLATION

- A. General:
  - 1. Install communication system in accordance with Manufacturer's written instructions, as indicated on the Drawings and as specified herein.
  - 2. Provide all cable, equipment, miscellaneous parts and accessories to make a complete and fully operational system as described herein.
  - 3. Equipment shall be installed and wired in accordance with accepted engineering and installation practices. Only the highest degree of workmanship will be accepted. All Work is subject to the Owner/Engineer's approval. Work that does not meet approval shall be rectified to their satisfaction at the sole expense of the Contractor.
- B. Speaker Wiring
  - 1. Refer to Section 27 15 00.
  - 2. The intercom contractor shall provide and install all cabling, clips, hangers, j-hooks, etc. as required.
  - 3. Wiring shall be in accordance with the Manufacturer's specifications. Wiring shall meet all local and state codes. All wiring shall be tested per category 6 standards.

4. All wiring shall be listed for the intended purpose. The cabling shall be Cat6 for all connections from the IDF or MDF to the classroom and or zone origination point. All IP speakers shall be homerun connected to each local IDF that serves that area, or MDF as noted on plans. There shall be no additional cabling required from the IDF to the MDF as this is accomplished through the shared fiber network devices and infrastructure. All interior wiring shall be in accordance with new construction guidelines suggested by the Manufacturer, including the speaker and the call-in switch.

C. Power Supply Wiring

1. Provide power supply wiring to the amplified speakers.
2. Wiring shall be as required by manufacturer for length installed, 16 gauge minimum.

2.6 TESTING

- A. Upon completion of the installation, all systems must be completely tested by the respective manufacturer's representative, and all necessary modifications and/or adjustments must be made to assure compliance with this specification. Testing shall be performed in the presence of the Owner's representative at a time mutually agreed upon by the Contractor and Owner's representative.
- B. Testing shall include functionality of interface between the Intercom systems and Owners phone system, and shall not be conducted until phone system is operational and able to be tested in this manner.

2.7 PROGRAMMING

- A. All programming of system shall be done by Contractor at the direction of the Owner. Allow for sufficient time to program entire system.
- B. Upon completion of programming, training and acceptance of system, provide the Owner with a computer disk containing all specific system programming.

2.8 FIELD QUALITY CONTROL

- A. Manufacturer's field service: Contractor shall arrange and pay for the services of a factory-authorized service representative to supervise the initial start-up, pretesting and adjustment of the school communication system. Objectives shall be to:
  1. Assure school communication system installation conforms with specified requirements and operates within specified tolerances.
  2. Field test and inspect to ensure operation is in accordance with Manufacturer's recommendations and Specifications.
  3. Prepare final test report including results, observations, failures, adjustments and remedies.
  4. Verify settings and make final adjustments.
- B. At least three weeks prior to any testing, notify the Engineer so that arrangements can be made for witnessing tests, if deemed necessary. All pretesting shall have been tested satisfactorily prior to the Engineer's witnessed test.
- C. Pretesting:
  1. Upon completing system installation, adjust the system and perform complete pretesting to determine conformance with the requirements of the Contract Documents. Correct

- any deficiencies observed in the pretesting. Replace all malfunctioning or damaged items and retest until satisfactory results are achieved.
2. Continuity tests of circuits.
- D. Visual and mechanical inspection:
1. Inspect for physical damage, defects alignment and fit.
  2. Perform mechanical operational tests in accordance with Manufacturer's instructions.
  3. Compare nameplate information and connections to Contract Documents.
  4. Check tightness of all connections.
  5. Check that all covers, barriers and doors are secure.
- E. Electrical tests: Perform an operational test to verify conformance of system performance and conditions to Contract Document within Manufacturer's tolerances.
- F. In the event that the system fails to function properly during the testing as a result of inadequate pretesting or preparation, the Contractor shall bear all costs incurred by the necessity for retesting including test equipment, transportation, subsistence and Engineer's hourly rate.
- G. Contractor shall replace at no cost to the Owner all devices which are found defective or do not operate within factory specified tolerances.
- H. Contractor shall submit the testing final report to the Engineer for review prior to Project closeout and final acceptance by the Owner. Test report shall indicate test dates, devices tested, results, observations, deficiencies and remedies. Include a copy of the test report in the Owner's operation and maintenance manuals.

## 2.9 TRAINING

- A. Factory authorized service representative shall conduct two 2 hour training seminars for Owner's representative upon completion and acceptance of system. Instructions shall include safe operation, maintenance, system programming, schedule changes and testing of equipment.
- B. Contractor shall schedule training with a minimum of 7 days advance notice.

**END OF SECTION 27 51 23**





August 7, 2014  
Wise Project No. 1407-245

Broadbent & Associates, Inc.  
5450 Louie Lane # 101  
Reno, NV 89511

**Attn: Mr. Brandon Reiff**

**Re: LIMITED SCOPE LEAD BUILDING SURVEY – PROPERTY TRANSFER  
Former Post Office Building  
3368 Sandy Way, South Lake Tahoe, CA**

Ladies and Gentlemen:

On Thursday, July 24, 2014, an environmental consultant from Wise Consulting & Training, Inc. (WISE) conducted a limited-scope lead property transfer survey at the site listed above. **Our lead survey scope of work included investigating for the presence, or absence, of Lead-Based Paint (LBP) or Lead-Containing Paint (LCP) and Lead Components at the site referenced herein.**

For property transfer surveys, we consider any paint surface that is equal to or below 0.10 milligrams per square centimeter ( $\text{mg}/\text{c}^2$ ) very low or no-lead paint for the purpose of normal renovation/demolition work. Any paint surface that is between 0.10 ( $\text{mg}/\text{c}^2$ ) and 1.0 ( $\text{mg}/\text{c}^2$ ) is considered Lead-Containing Paint (LCP). Paint surfaces measuring 1.0  $\text{mg}/\text{cm}^2$  or higher are Lead-Based Paint (LBP). Similar recommendations apply to lead components such as lead lined drywall, roof scuppers, lead solder with high lead concentrations, ceramic tile and other.

This survey was conducted with the use of a Niton XLp 703 AW XRF Analyzer with current calibration operated by a trained and EPA and CDPH accredited Lead Inspector/Risk Assessor. If any inconclusive or atypical readings are recorded, the inspector will conduct chip sampling and laboratory analysis of the paint film to resolve the inconclusive or atypical XRF readings. No inconclusive readings were recorded at the site.

## **FINDINGS**

The following table summarizes the paint description, paint combination location, sample result, and condition of the paint combination for the building. Under the tables we have also provided a summary of the where the paint surfaces fall in our lead classification system.

XRF RESULTS SUMMARY TABLE					
Former Post Office					
3368 Sandy Way, South Lake Tahoe, CA					
DESCRIPTION					XRF RESULT mg/cm <sup>2</sup>
Location	Component	Substrate	Condition	Color	
Floor Front Area	12"x12" Ceramic Tile	Ceramic	Good	White	0.00, 0.00, 0.00, 0.00
Floor Front Area	12"x12" Ceramic Tile	Ceramic	Blue	White	0.00, 0.00, 0.05, 0.04
Interior, Front Area	Cove Base	Ceramic	Good	Blue	0.02, 0.03, 0.05
Interior	Wall	Drywall	Good	White	0.00, 0.00, 0.00, 0.00, 0.00
Interior	Wall	Drywall	Good	Yellow	0.00, 0.00, 0.00
Interior	Wall	Drywall	Good	Red	0.00, 0.00
Men's and Women's Restroom Walls	4"x4" Ceramic Tile	Ceramic	Good	White	0.01, 0.01, 0.00
Men's and Women's Restroom Walls	Cove Base	Ceramic	Good	Tan	0.00, 0.00, 0.00
Men's and Women's Restroom Walls	4"x4" Ceramic Tile	Ceramic	Good	Blue	0.00, 0.00, 0.00
Men's and Women's Restroom Floor	7"x7" Ceramic Tile	Ceramic	Good	White	0.01, 0.01, 0.00
Interior, Rear Area	Door Frame	Metal	Good	Grey	0.07, 0.18, 0.09
Exterior	Wall	Wood	Good	Grey	0.01, 0.01, 0.04, 0.05
*Notes					
Good = No significant deterioration (chipping peeling, oxidation).					
Deteriorated = Greater than 2 square feet of small components (trim) deteriorated; on interior surfaces greater than 10 percent; or greater than 10 square feet on exterior surfaces.					
NA = No or very low lead content, No Action recommended.					

***Based on the results presented above the tested surfaces are classified as follows:***

**Lead-Based Paint**

***No Lead -Based Paint was detected.***

**Lead- Containing Component**

***Lead- Containing Paint was detected on the interior door frames.***

**No or Very Low Lead**

***No or very low lead was detected on every other surface tested.***

**CONSLUSIONS and RECOMENDATIONS**

***Our inspection was conducted to locate and identify LBP and LCP on major components of the building, not every surface of the interior and exterior was tested.***

***Prior to conducting any type of renovation, we recommend this survey be checked and any surfaces or materials not samples that may have a lead presence should be checked prior to disturbance to be in compliance with CA lead regulation requirements. Please do not hesitate to ask for clarification, if you have any questions regarding this report or our conclusions and recommendations.***

## **CLOSURE**

It was not the intent of this study to find buried paint surfaces or to conduct excessive destructive means to find suspect lead components. It was the purpose to find and sample accessible suspect paint combinations and/or components, including multi-layered paints, in the area..

This report represents information pertaining to the specific sample locations and paint conditions at the time the survey was conducted. No other observations, guarantees, or warranties are either expressed or implied.

Thank you for the opportunity to be of service on this project.

*Prepared By:*



Dana J. Carlton, Environmental Consultant  
CA Lead Consultant DPH #11007

*Reviewed and Approved By:*



J. Tom Wise, President/Technical Director



August 7, 2014  
Wise Project No. 1407-245

Broadbent & Associates, Inc.  
5450 Louie Lane # 101  
Reno, NV 89511

**Attn: Mr. Brandon Reiff**

**Re: LIMITED SCOPE ASBESTOS BUILDING SURVEY – PROPERTY TRANSFER  
Former Post Office Building  
3368 Sandy Way, South Lake Tahoe, CA**

Ladies and Gentlemen:

On Thursday, July 24, 2014, a consultant from Wise Consulting and Training, Inc. (WISE) conducted a limited scope asbestos property transfer survey at the above referenced facility. The purpose of the survey was to determine if Asbestos Containing Material (ACM) exists in a limited number of the major component materials at the facility. **The sampling conducted was not sufficient in quantity to refute the presence of ACM in the materials sampled per EPA and OSHA regulation protocols, but positive results do confirm the presence of ACM.**

The survey work included conducting a visual inspection of the facility to determine types of building materials present, then developing and implementing a sampling plan of a limited number of the major accessible suspect ACM. Samples were collected from Seven (7) locations resulting in eleven (11) analyses, including sample splits, for asbestos content by EPA Method 600/R-93-116. The reason for sample split is more than one material was present in a sample and each material must be analyzed separately per EPA mandated laboratory protocols.

## FINDINGS

The following table summarizes the material description, location, sample numbers, and condition of all materials determined to be ACM. Per EPA and OSHA regulation definitions, ACM are materials containing greater than one percent (>1%) asbestos.

ACM Summary Data 3368 Sandy Way, South Lake Tahoe, CA			
Material Description	Material Location	Sample Number & Asbestos Content	*Condition
Floor Tile Mastic (Black)	Typical Throughout Survey Area, Under 12"x12" Floor Tile	3368-F-01 1-5% Chrysotile	Good
Wall Texture	Typical Throughout Survey Area.	3368-W-06 1-5% Chrysotile	Good
*Note:			
Good	=	Material Intact	
Fair	=	Material basically intact; limited areas of disturbance <10%	
Poor	=	Greater than 10% disturbed	

The materials that did not indicate regulated quantities of asbestos in our limited sampling are listed below. Note that additional samples of these materials would need to be collected and analyzed to confirm they are not ACM per EPA renovation or demolition survey protocols.

- Floor Tile Mastic (Yellow)- Typical throughout survey area, between 12"x12" Floor Tile and (Black) Floor Tile Mastic.
- 2'x2' Ceiling Tiles- Typical in front area.
- 2'x4' Ceiling Tiles- Typical in rear area.
- Sheet Flooring- Typical in Foyer area.

All materials determined to be ACM are currently in good condition and therefore do not create a health issue for the continuing operation of the building. The presence of ACM indicates that the imposition of a management program to insure that materials are maintained in good condition is warranted. Also, prior to renovation that will disturb ACM or suspect ACM, an Asbestos Renovation Survey should be completed and all AMC that will be impacted by the renovation should be properly abated to comply with federal and state regulations.

## CLOSURE

This report consists of this written report, the laboratory analytical report, and the survey data sheet. If any portions of this report are missing, the report should be considered incomplete.

It was not the intent of this study to conduct a full EPA renovation/demolition survey. It also was not the intent to find buried materials, conduct excessive destructive sampling, or to sample those materials that are not commonly considered asbestos containing for the purposes of building renovation or demolition. The purpose of this survey was to find and sample a limited

number of accessible components that are suspect materials, including multi-layered materials to determine if regulated quantities of asbestos were present.

The condition of ACM may change over time. In addition, asbestos content will vary from location to location within materials due to manufacturing and application processes. This report represents information relating to the specific sample locations and material conditions at the time the survey was conducted. No other claims, warranties, or guarantees are either expressed or implied.

We have issued this report for the use of the above listed Client only.

Prepared By:



Dana J. Carlton, Environmental Consultant  
CA Asbestos Consultant # 01-2915

Reviewed and Approved By:



J. Tom Wise, President / Technical Director  
CA Asbestos Consultant # 92-0340

Enc.: Polarized Light Microscopy Analysis Report No.126432

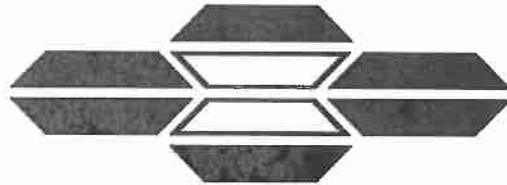

**ASBESTOS TEM LABORATORIES, INC.**

**EPA Method 600/R-93/116  
Polarized Light Microscopy  
Analytical Report**

**Report No. 126432**

1350 Freeport Blvd., Unit 104  
Sparks, NV 89431  
(775) 359-3377  
FAX (775) 359-2798

*With Main Office Located At:*  
630 Bancroft Way, Berkeley, CA 94710  
Ph. (510) 704-8930 Fax (510) 704-8929



ASBESTOS TEM LABORATORIES, INC

Accredited by



NVLAP Lab Code 200104-0

Jul-30-14

Mr. Dana Carlton  
Wise Consulting & Training  
500 Ryland, Suite 250  
Reno, NV 89502

RE: LABORATORY JOB # 871-###

Polarized light microscopy analytical results for 7 bulk sample(s) with 4 sample split(s)  
Job Site: Former Post Office, 3368 Sandy Way, South Lake Tahoe, CA  
Job No.: 1407-245  
Report No.: 126432

Enclosed please find the bulk material analytical results for one or more samples submitted for asbestos analysis. The analyses were performed in accordance with EPA Method 600/R-93/116 or 600/M4-82-020 for the determination of asbestos in bulk building materials by polarized light microscopy (PLM). Please note that while PLM analysis is commonly performed on non-friable and fine grained materials such as floor tiles and dust, the EPA method recognizes that PLM is subject to limitations. In these situations, accurate results may only be obtainable through the use of more sophisticated and accurate techniques such as transmission electron microscopy (TEM) or X-ray diffraction (XRD).

Prior to analysis, samples are logged-in and all data pertinent to the sample recorded. The samples are checked for damage or disruption of any chain-of-custody seals. A unique laboratory ID number is assigned to each sample. A hard copy log-in sheet containing all pertinent information concerning the sample is generated. This and all other relevant paper work are kept with the sample throughout the analytical procedures to assure proper analysis.

Each sample is opened in a class 100 HEPA negative air hood. A representative sampling of the material is selected and placed onto a glass microscope slide containing a drop of refractive index oil. The glass slide is placed under a polarizing light microscope where standard mineralogical techniques are used to analyze and quantify the various materials present, including asbestos. The data is then compiled into standard report format and subjected to a thorough quality assurance check before the information is released to the client.

For possible future reference, samples are normally kept on file for one year.

Sincerely Yours,

Laboratory Analyst  
ASBESTOS TEM LABORATORIES, INC.

--- These results relate only to the samples tested and must not be reproduced, except in full, with the approval of the laboratory. This report must not be used to claim product endorsement by NVLAP or any other agency of the U.S. Government. ---









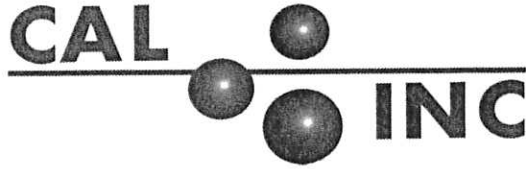

## VISUAL CLEARANCE CERTIFICATION

<b>Project Name:</b> Asbestos Drywall & Flooring	<b>Date:</b> 10/16/2014
<b>Project Number:</b> 20220	<b>Project Location:</b> Tahoe, CA
<b>Project Manager:</b> David Smith	<b>Superintendent:</b> Mike Henry
<b>Work Area (describe):</b>	

Visual Checklist			
Visual dust or debris on:	PASS	FAIL	COMMENTS
Floor	X		
Horizontal Surfaces	X		
Pipes	N/A		
Ventilation Equipment	X		
Vertical Surfaces	X		
Ducts	X		
Registers	X		
Lights	N/A		
Equipment	X		
Coils	N/A		

Notes:

---

---

---

---

---

---

---

---

David Smith  
 \_\_\_\_\_  
 Project Manager - Print

*David Smith*  
 \_\_\_\_\_  
 Project Manager - Signature

Mike Henry  
 \_\_\_\_\_  
 Superintendent - Print

*Mike Henry*  
 \_\_\_\_\_  
 Superintendent - Signature

**Asbestos Building  
Inspection/Survey**

*EDC HHS Tenant Improvement*

*3368 Sandy Way  
South Lake Tahoe, CA 96150*

**Presented to:**

*Dan Evans  
Facilities Project Manager*

*County of El Dorado  
3000 Fairlane Court, Suite 1  
Placerville, CA 95667*

**Inspection Date:**

*September 27, 2018*

**Conducted by:**

*Anthony M. De Arcos  
Certified Asbestos Consultant  
Registered Environmental Property Assessor  
and  
Justin S. Gardner  
Certified Site Surveillance Technician*

**National Analytical Laboratories, Inc.**

*2201 Francisco Dr., Ste. 140-261  
El Dorado Hills, CA 95762  
Office: (916) 361-0555 | Fax: (916) 361-0540  
E-Mail: NAL1@NAL1.com | Web Page: www.NAL1.com*





October 03, 2018

Dan Evans  
Facilities Project Manger  
County of El Dorado  
3000 Fairlane Court, Suite 1  
Placerville, CA 95667

RE: **Asbestos Building Inspection/Survey**  
EDC HHS Tenant Improvement  
3368 Sandy Way  
South Lake Tahoe, CA 96150

Dear Mr. Evans,

The following report is in regards to the asbestos building inspection conducted at 3368 Sandy Way, in South Lake Tahoe, CA. **Of the twelve (12) suspected asbestos containing samples collected, three (3) were found to contain asbestos containing construction materials (ACCM).** Justin S. Gardner, working under supervision of Anthony M. De Arcos, Certified Asbestos Consultant and Registered Environmental Property Assessor, for National Analytical Laboratories, Inc. (N.A.L.), conducted the inspection on September 27, 2018.

### ***SUMMARY OF FINDINGS -***

**Based on the sample results the Gray Window Glazing Compound (~75 sf) and the Roof Gray/Black Mastic (~80 sf) were found to contain ACCM.** All square footage should be verified by contractor.

### ***ASBESTOS INSPECTION –***

The inspection was completed according to the EPA's Asbestos Containing Building Materials (ACBM) In-Schools Rule; 40 CFR 763.85 (Inspection and Re-Inspection). Currently, EPA regulations classify ACBM as materials containing more that 1-percent (1%) of asbestos. Cal-OSHA currently regulates asbestos to 1/10<sup>th</sup> of 1% (0.1%) and requires that a certified asbestos worker conduct this work.

Upon completion of the visual inspection, the suspect asbestos bulk sample materials were collected in accordance with EPA and OSHA protocol. They were placed into new, air tight, plastic bags, sealed, and identified with unique identification numbers. The bulk samples were transported to the laboratory under chain of custody protocol for analysis.

Breathe easy.....

No destructive, only renovation sampling was conducted during the site visit, in the event that future renovation and/or demolition work reveals any unforeseen suspect materials; the contractor shall contact the project manager for further testing.

EMSL Analytical, Inc. (EMSL) in Carle Place, New York, analyzed the bulk suspect asbestos containing samples, utilizing Polarized Light Microscopy (PLM) Method. National Voluntary Laboratory Accreditation Program (NVLAP) certification #101048-10 and California Environmental Laboratory Accreditation Program (CAELAP) certification #2339, certifies EMSL.

*Although not all the rooms or materials throughout the site were sampled, the like materials that were not tested will be treated as homogeneous to the materials that were tested, and will be considered as containing ACCM or Non-ACCM in accordance to the results.*

The location and results of suspect samples found to **contain ACCM** are as follows:

Sample ID#	Material	Location	Category	Results
3368-8AS	Gray Glazing Compound	Additional Sampling - South Center Area, South Window (-75 sf)	II	2% Chrysotile
3368-10AS	Gray/Black Mastic	Additional Sampling - Roof At AC1, Southeast Curb (-60 sf)	I	4% Chrysotile
3368-12AS	Gray/Black Mastic	Additional Sampling - West Side Plumbing Penetration (-20 sf)	I	2% Chrysotile

sf = Square Feet; Category I & II are Non-friable/Non-hazardous Materials.

The Roof Gray/Black Mastic and Gray Window Glazing Compound are considered Category I and II, non-friable/non-hazardous materials, which can be removed and disposed of at a non-hazardous waste facility.

The following samples were **non-asbestos containing** materials:

Sample ID#	Material	Location	Results
3368-1AS	Texture	Additional Sampling - Southeast Area, South Drywall Wall (-500 sf)	None Detected
3368-2AS	Texture	Additional Sampling - Northwest Area, North Wall	None Detected
3368-3AS	Texture	Additional Sampling - Center Open Area At Metal I-Beam	None Detected
3368-4AS	Heavy Knock Down Texture	Additional Sampling - West Open Area, West Wall, North End (-120 sf)	None Detected
3368-5AS	Heavy Knock Down Texture	Additional Sampling - West Open Area, West Wall, South End	None Detected
3368-6AS	Heavy Knock Down Texture	Additional Sampling - West Open Area, West Wall, Center Upper End	None Detected
3368-7AS	Mortar	Additional Sampling - Northwest Area Floor (-300 sf)	None Detected
3368-9AS	Sheetrock-Joint Compound	Additional Sampling - Southeast Electrical Panel Room, West Wall (-50 sf)	None Detected



Sample ID#	Material	Location	Results
3368-11AS	Gray Composition Rolled Roofing	Additional Sampling - East Side Roof (-6,800 sf)	None Detected

sf = Square Feet

**ASBESTOS RECOMMENDATION –**

Federal and state regulations require that anyone disturbing asbestos containing materials are properly trained certified and have the required respiratory protection and medical surveillance.

N.A.L. recommends that a certified asbestos abatement contractor be retained to remove the non-friable materials, prior to any scheduled renovation/demolition work being completed at the site. Prior to the work process starting, a work plan or specifications in regards to the abatement process should be completed and distributed to the abatement contractors during the job walk at the site.

On-Site Observation should be conducted by N.A.L.'s Certified Asbestos Consultant or Certified Site Surveillance Technician, to verify that the work plan/specification is being followed. Once a certified asbestos contractor has removed the ACCM, following EPA and OSHA requirements; a visual inspection and air clearance sampling should be completed. A clearance will confirm that the general contractor can reoccupy the work area(s), without concern for exposure to asbestos airborne fibers to their employees thus allowing the renovation or demolition work to be completed by the general contractor.

Included at the end of this report are the laboratory analytical results, chain of custody form, and sample location map. If you have any questions regarding this report or if we can be of further assistance, please contact our office.

Reviewed and submitted by:

*Anthony M. De Arcos*

Anthony M. De Arcos  
 Certified Asbestos Consultant,  
 DOSH# 92-0261  
 Registered Environmental Property Assessor,  
 REPA# 938322039

*Justin S. Gardner*

Justin S. Gardner  
 Certified Site Surveillance Technician,  
 DOSH# 28096







# EMSL Analytical, Inc.

528 Mineola Avenue Carle Place, NY 11514  
Tel/Fax: (516) 997-7251 / (516) 997-7528  
<http://www.EMSL.com> / [carleplacelab@emsl.com](mailto:carleplacelab@emsl.com)

**EMSL Order:** 061820275  
**Customer ID:** NAL51  
**Customer PO:** 4017 / 121  
**Project ID:**

**Attention:** Paula Lee  
National Analytical Laboratories (NAL)  
2201 Francisco Dr.  
Ste. 140-261  
El Dorado Hills, CA 95762  
**Phone:** (916) 361-0555  
**Fax:** (916) 361-0540  
**Received Date:** 10/02/2018 11:02 AM  
**Analysis Date:** 10/02/2018 - 10/03/2018  
**Collected Date:** 09/27/2018  
**Project:** # 4017 / 121. EDC HHS Tenant Improvement: 3368 Sandy Way, South Lake Tahoe, CA 96150

## Test Report: Asbestos Analysis of Bulk Materials via EPA 600/R-93/116 Method using Polarized Light Microscopy

Sample	Description	Appearance	Non-Asbestos		Asbestos % Type
			% Fibrous	% Non-Fibrous	
368-1AS <small>061820275-0001</small>	Additional Sampling - Southeast Area, South Drywall Wall (-500sf) - Texture	Brown/Tan Non-Fibrous Heterogeneous	6% Cellulose	30% Ca Carbonate 45% Gypsum 5% Mica 14% Non-fibrous (Other)	None Detected
368-2AS <small>061820275-0002</small>	Additional Sampling - Northwest Area, North Wall - Texture	Tan/White Non-Fibrous Heterogeneous	4% Cellulose	55% Ca Carbonate 23% Mica 18% Non-fibrous (Other)	None Detected
368-3AS <small>061820275-0003</small>	Additional Sampling - Center Open Area at Metal I-Beam - Texture	Tan/White Non-Fibrous Homogeneous	3% Cellulose	55% Ca Carbonate 5% Mica 15% Matrix 22% Non-fibrous (Other)	None Detected
368-7AS <small>061820275-0007</small>	Additional Sampling - Northwest Area Floor (-300sf) - Mortar	White Non-Fibrous Homogeneous		60% Quartz 25% Ca Carbonate 15% Non-fibrous (Other)	None Detected
368-8AS <small>061820275-0008</small>	Additional Sampling - South Center Area, South Window (-75sf) - Gray Glazing Compound	Gray Non-Fibrous Homogeneous		78% Ca Carbonate 3% Mica 17% Non-fibrous (Other)	2% Chrysotile
368-9AS <small>061820275-0009</small>	Additional Sampling - Southeast Electrical Panel Room, West Wall (-50sf) - Sheetrock- Joint Compound	Brown/Tan/White Non-Fibrous Homogeneous	4% Cellulose	75% Ca Carbonate 8% Mica 13% Non-fibrous (Other)	None Detected
368-10AS <small>061820275-0010</small>	Additional Sampling - Roof At AC1, Southeast Curb (-60sf) - Gray/Black Mastic	Black Non-Fibrous Homogeneous		10% Ca Carbonate 65% Matrix 21% Non-fibrous (Other)	4% Chrysotile
368-11AS <small>061820275-0011</small>	Additional Sampling - East Side Room (-6800sf) - Gray Composition Rolled Roofing	Black Non-Fibrous Homogeneous	3% Cellulose 7% Glass	10% Ca Carbonate 52% Matrix 28% Non-fibrous (Other)	None Detected
368-12AS <small>061820275-0012</small>	Additional Sampling - West Side Plumbing Penetration (-20sf) - Gray/Black Mastic	Black Non-Fibrous Homogeneous	3% Glass	9% Ca Carbonate 60% Matrix 26% Non-fibrous (Other)	2% Chrysotile

Initial report from: 10/03/2018 09:31:06



# EMSL Analytical, Inc.

528 Mineola Avenue Carle Place, NY 11514

Tel/Fax: (516) 997-7251 / (516) 997-7528

<http://www.EMSL.com> / [carleplacelab@emsl.com](mailto:carleplacelab@emsl.com)

**EMSL Order:** 061820275

**Customer ID:** NAL51

**Customer PO:** 4017 / 121

**Project ID:**

Analyst(s)

Jimmy Encalada (9)

Daniel Clarke, Asbestos Laboratory Manager  
or Other Approved Signatory

EMSL maintains liability limited to cost of analysis. The above analyses were performed in general compliance with Appendix E to Subpart E of 40 CFR (previously EPA 600/M4-82-020 "Interim Method"), but augmented with procedures outlined in the 1993 ("final") version of the method. This report relates only to the samples reported above, and may not be reproduced, except in full, without written approval by EMSL. EMSL bears no responsibility for sample collection activities or analytical method limitations. Interpretation and use of test results are the responsibility of the client. All samples received in acceptable condition unless otherwise noted. This report must not be used by the client to claim product certification, approval, or endorsement by NVLAP, NIST or any agency of the federal government. EMSL recommends gravimetric reduction for all non-friable organically bound materials prior to analysis. Estimation of uncertainty is available on request.

Samples analyzed by EMSL Analytical, Inc. Carle Place, NY NVLAP Lab Code 101048-10, CA ELAP 2339, NYS ELAP 11469

Initial report from: 10/03/2018 09:31:06



# EMSL Analytical, Inc.

528 Mineola Avenue Carle Place, NY 11514  
Phone/Fax: (516) 997-7251 / (516) 997-7528  
<http://www.EMSL.com> / [carleplacelab@emsl.com](mailto:carleplacelab@emsl.com)

**EMSL Order:** 061820275  
**Customer ID:** NAL51  
**Customer PO:** 4017 / 121  
**Project ID:**

**Attention:** Paula Lee  
National Analytical Laboratories (NAL)  
2201 Francisco Dr.  
Ste. 140-261  
El Dorado Hills, CA 95762  
**Phone:** (916) 361-0555  
**Fax:** (916) 361-0540  
**Received:** 10/02/2018 11:02 AM  
**Analysis Date:** 10/02/2018  
**Collected:** 09/27/2018  
**Project:** # 4017 / 121. EDC HHS Tenant Improvement: 3368 Sandy Way, South Lake Tahoe, CA 96150

## Test Report: Asbestos Analysis of Bulk Materials via EPA 600/R-93/116 Method using Polarized Light Microscopy. Quantitation using 400 Point Count Procedure

Sample	Description	Appearance	Non-Asbestos		Asbestos
			% Fibrous	% Non-Fibrous	% Type
368-4AS 061820275-0004	Additional Sampling - West Open Area, West Wall, North End - Heavy Knock Down Texture	Tan/White Non-Fibrous Heterogeneous	6% Cellulose	40% Ca Carbonate 4% Mica 30% Matrix 19.50% Non-fibrous (Other)	<b>0.50% Chrysotile</b>
368-5AS 061820275-0005	Additional Sampling - West Open Area, West Wall, South End - Heavy Knock Down Texture	Brown/Tan/White Non-Fibrous Heterogeneous	7% Cellulose	53% Ca Carbonate 5% Mica 34.50% Non-fibrous (Other)	<b>0.50% Chrysotile</b>
368-6AS 061820275-0006	Additional Sampling - West Open Area, West Wall, Center Upper End - Heavy Knock Down Texture	Tan/White Non-Fibrous Heterogeneous	7% Cellulose	48% Ca Carbonate 5% Mica 39.50% Non-fibrous (Other)	<b>0.50% Chrysotile</b>

Analyst(s)

Jimmy Encalada (3)

Daniel Clarke, Asbestos Laboratory Manager  
or other approved signatory

Disclaimer: Some samples may contain asbestos fibers present in dimensions below PLM resolution limits. The limit of detection as stated in the method is 0.25%. EMSL Analytical Inc suggests that samples reported as <0.25% or none detected undergo additional analysis via TEM. The above test report relates only to the items tested. This report may not be reproduced, except in full, without written approval of EMSL Analytical Inc. This test report must not be used by the client to claim product endorsement by NVLAP or any agency of the United States Government. EMSL Analytical Inc., bears no responsibility for sample collection activities, analytical method limitations, or the accuracy of results when requested to separate layered samples. EMSL Analytical Inc., liability is limited to the cost of sample analysis. The test results contained within this report meet the requirements of NELAC unless otherwise noted. Samples received in good condition unless otherwise noted. Unless requested by the client, building materials manufactured with multiple layers (i.e. linoleum, wallboard, etc.) are reported as a single sample.

Samples analyzed by EMSL Analytical, Inc. Carle Place, NY NVLAP Lab Code 101048-10, CA ELAP 2339, NYS ELAP 11469

Initial report from: 10/03/2018 09:31:01

061820275



**NAL LOG-IN RECORD**

**Login # 40103**

Ph: 916.361.0555 Fx: 916.361.0540

**National Analytical Laboratories, Inc.**

**Job Site/Job #:**

Client#-Lot# 4017 / 121  
 County of El Dorado  
 Phone Number  
 FAX Number  
 Contact Dan Evans  
 E-Mail Address

EDC HHS Tenant Improvement:  
 3368 Sandy Way  
 South Lake Tahoe, CA 96150

Date 9/20/2018  
 Sampling Date: 9/27/2018  
 Sampling Time 11:00:00 AM  
 Type Of Work: PLM-BI  
 No. of Samples 12  
 Turnaround: 6 hours

Num.	Sample ID#	Location/Description
1	3368-1AS	Additional Sampling - Southeast Area, South Drywall Wall (-500sf) / Texture
2	3368-2AS	Additional Sampling - Northwest Area, North Wall / Texture
3	3368-3AS	Additional Sampling - Center Open Area At Metal I-Beam / Texture
4	3368-4AS	Additional Sampling - West Open Area, West Wall, North End 2050sf / Heavy Knock Down Texture
5	3368-5AS	Additional Sampling - West Open Area, West Wall, South End / Heavy Knock Down Texture
6	3368-6AS	Additional Sampling - West Open Area, West Wall, Center Upper End / Heavy Knock Down Texture
7	3368-7AS	Additional Sampling - Northwest Area Floor (-300sf) / Mortar
8	3368-8AS	Additional Sampling - South Center Area, South Window (-75sf) / Gray Glazing Compound
9	3368-9AS	Additional Sampling - Southeast Electrical Panel Room, West Wall (-50sf) / Sheetrock-Joint Compound
10	3368-10AS	Additional Sampling - Roof At AC1, Southeast Curb (-60sf) / Gray/Black Mastic

RECEIVED  
 ANALYTICAL INC  
 10-2-18  
 11:02  
 10-2-18  
 11:02

**Chain of Custody Information**

Released By Signature	Date/Time	Received By Signature	Date/Time	Due:
<i>Justin Gardner</i>	10118	<i>S. Gould</i>	10-2-18 11:02	
Released By Signature	Date/Time	Received By Signature	Date/Time	At:

*Justin Gardner* 10-2-18 912 Rev/3rd B 6042 of 806  
 BOS Rcvd 1-24-19

061820275



**NAL LOG-IN RECORD**

**Login # 40103**

Ph: 916.361.0555 Fx: 916.361.0540

**National Analytical Laboratories, Inc.**

**Job Site/Job #:**

Client#-Lot# 4017 / 121  
 County of El Dorado  
 Phone Number  
 FAX Number  
 Contact Dan Evans  
 E-Mail Address

EDC HHS Tenant Improvement:  
 3368 Sandy Way  
 South Lake Tahoe, CA 96150

Date 9/20/2018  
 Sampling Date: 9/27/2018  
 Sampling Time 11:00:00 AM  
 Type Of Work: PLM-BI  
 No. of Samples 12  
 Turnaround: 6 hours

Num.	Sample ID#	Location/Description
11	3368-11AS	Additional Sampling - East Side Roof (-6800sf) / Gray Composition Rolled Roofing
12	3368-12AS	Additional Sampling - West Side Plumbing Penetration (-20sf) / Gray/Black Mastic

**\*IF RESULTS ARE LESS THAN 1%, PLEASE 400 POINT COUNT**

RECEIVED  
 ENSL ANALYTICAL, INC.  
 CARLE PLACE, NY  
 18 OCT -2 AM 11:02

**Chain of Custody Information**

Released By Signature	Date/Time	Received By Signature	Date/Time	Due:
<i>Justin Gardner</i>	10118	<i>S. Gould</i>	9-27-18 11:00	
Released By Signature	Date/Time	Received By Signature	Date/Time	At:

*Justin Gardner* 18, 9/12 Revised B, 605 of 606  
 BOS Rcvd 1-24-19

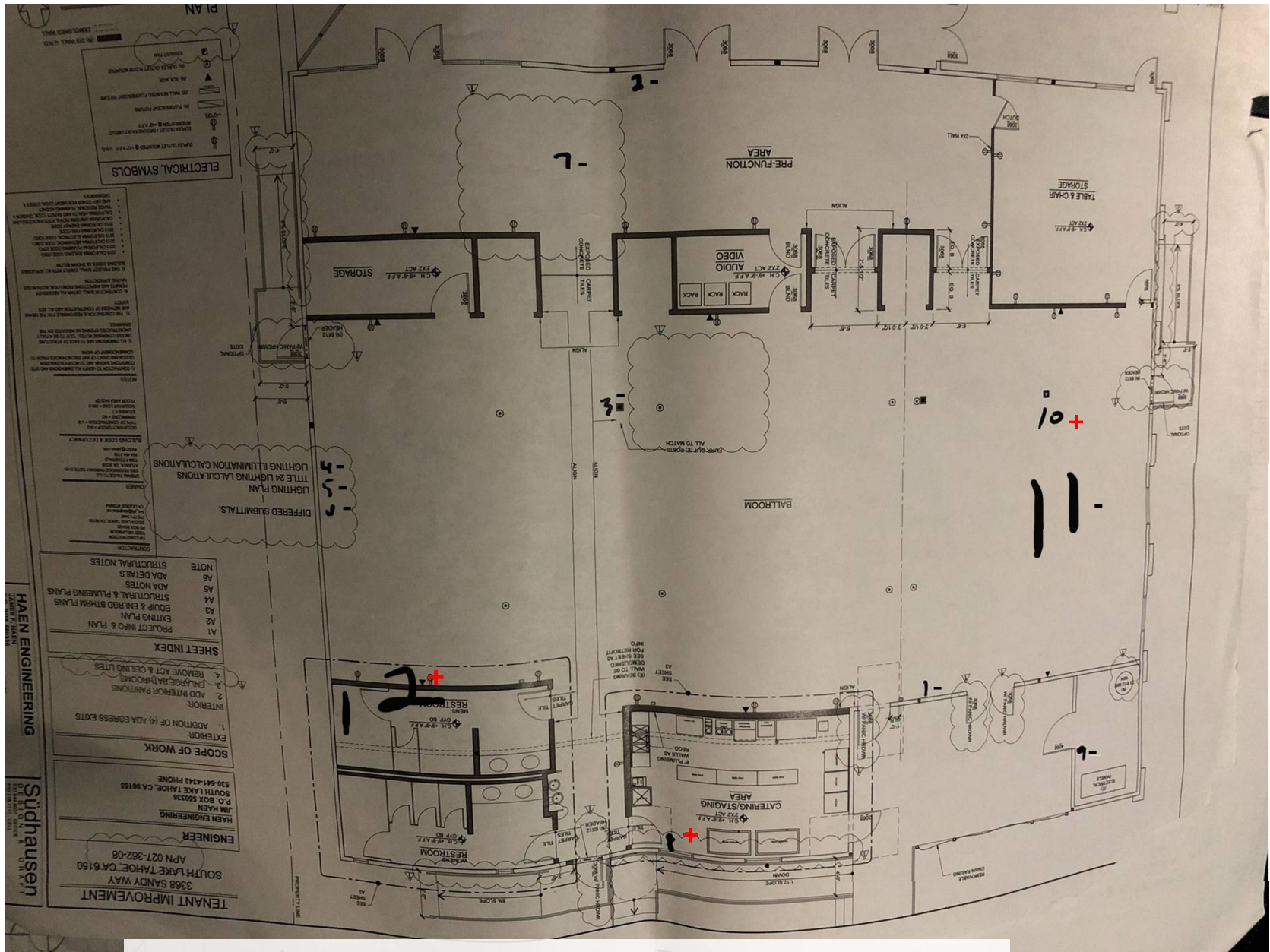

<b>ASBESTOS SAMPLE LOCATION MAP</b> Survey Date: <b>09/27/18</b> Area:	Site Name: Site Address: <b>3368 Sandy Way</b> <b>South Lake Tahoe, CA</b> <b>96150</b>	Project #: Scale: Not to scale Layout and sample locations are approximated. <b>Legend:</b> - Non-ACCM Samples + ACCM Samples	
	3688 SANDY WAY SOUTH LAKE TAHOE, CA 96150 APN 027-362-08 <b>JIM HAEN</b> P.O. BOX 55338 SOUTH LAKE TAHOE, CA 96155 530-941-1445 PHONE <b>HAEN ENGINEERING</b> 3368 SANDY WAY SOUTH LAKE TAHOE, CA 96150 APN 027-362-08 <b>ENGINEER</b>	<b>Sudhausen</b> 3368 SANDY WAY SOUTH LAKE TAHOE, CA 96150 APN 027-362-08 <b>ENGINEER</b>	

18-1912 Revised B 606 of 606  
 BOS Rcvd 1-24-19