

**COUNTY OF EL DORADO, CALIFORNIA
COMMUNITY DEVELOPMENT AGENCY**

TRANSPORTATION DIVISION

CONTRACT DOCUMENTS

INCLUDING

NOTICE TO BIDDERS, SPECIAL PROVISIONS,
PROPOSAL, AND CONTRACT
FOR

PATTERSON DRIVE AND MISSOURI FLAT ROAD OVERLAYS

CONTRACT PW No. 16-31119 / CIP No. 72190 / P&C No. 356-1699

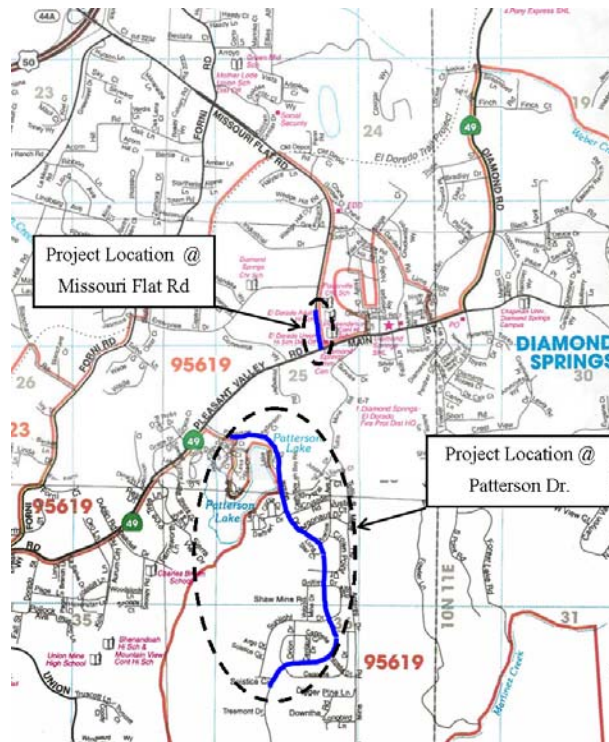

FOR USE WITH

STATE OF CALIFORNIA, DEPARTMENT OF TRANSPORTATION,
2010 STANDARD SPECIFICATIONS AND STANDARD PLANS

BID OPENING DATE: JUNE 29, 2016

**COUNTY OF EL DORADO, CALIFORNIA
COMMUNITY DEVELOPMENT AGENCY
TRANSPORTATION DIVISION**

CONTRACT DOCUMENTS

INCLUDING
NOTICE TO BIDDERS, SPECIAL PROVISIONS,
PROPOSAL, AND CONTRACT
FOR

PATTERSON DRIVE AND MISSOURI FLAT ROAD OVERLAYS

JUNE 29, 2016

PW No. 16-31119 / CIP No. 72190 / P&C No. 356-C1699

The various portions of the Contract Documents have been prepared under the direction of the following licensed Civil Engineer, in accordance with California Business and Professions Code § 6735.



Frank W. Whitmore III, RCE No. C78073

Date 4/19/16

COMMUNITY DEVELOPMENT AGENCY, TRANSPORTATION DIVISION
COUNTY OF EL DORADO, STATE OF CALIFORNIA

PATTERSON DRIVE AND MISSOURI FLAT ROAD OVERLAYS

CONTRACT NO. PW 16-31119, CIP NO. 72190, P&C NO. 356-C1699

TABLE OF CONTENTS

NOTICE TO BIDDERS	N-1
STANDARD PLAN LIST	SPL-1
SPECIAL PROVISIONS	SP-1
DIVISION I GENERAL PROVISIONS	SP-1
1 GENERAL	SP-1
2 BIDDING.....	SP-3
3 CONTRACT AWARD AND EXECUTION.....	SP-7
4 SCOPE OF WORK	SP-9
5 CONTROL OF WORK	SP-9
6 CONTROL OF MATERIALS.....	SP-12
7 LEGAL RELATIONS AND RESPONSIBILITY TO THE PUBLIC.....	SP-12
8 PROSECUTION AND PROGRESS	SP-15
9 PAYMENT	SP-17
DIVISION II GENERAL CONSTRUCTION.....	SP-19
10 GENERAL	SP-19
12 TEMPORARY TRAFFIC CONTROL	SP-20
13 WATER POLLUTION CONTROL.....	SP-29
14 ENVIRONMENTAL STEWARDSHIP	SP-30
15 EXISTING FACILITIES.....	SP-36
DIVISION III GRADING	SP-39
DIVISION IV SUBBASES AND BASES.....	SP-39
DIVISION V SURFACINGS AND PAVEMENTS.....	SP-39
39 HOT MIX ASPHALT.....	SP-39
DIVISION VI STRUCTURES	SP-48
DIVISION VII DRAINAGE.....	SP-48
DIVISION VIII MISCELLANEOUS CONSTRUCTION	SP-48
DIVISION IX TRAFFIC CONTROL FACILITIES.....	SP-48
84 TRAFFIC STRIPES AND PAVEMENT MARKINGS.....	SP-48
85 PAVEMENT MARKERS	SP-49

86 ELECTRICAL SYSTEMS	SP-49
DIVISION X MATERIALS.....	SP-52
88 GEOSYNTHETICS.....	SP-52
DIVISION XI BUILDING CONSTRUCTION	SP-52
APPENDIX A - REVISED STANDARD PLANS.....	RSS-1
APPENDIX B – CEQA EXEMPTION	B-1
APPENDIX C – EXHIBITS.....	C-1
AGREEMENT (DRAFT).....	D-1
Article 1. THE WORK.....	D-1
Article 2. CONTRACT DOCUMENTS.....	D-1
Article 3. COVENANTS AND CONTRACT PRICE	D-2
Article 4. COMMENCEMENT AND COMPLETION.....	D-2
Article 5. INDEMNITY	D-2
Article 6. VENUE	D-3
Article 7. NOTIFICATION OF SURETY COMPANY.....	D-3
Article 8. ASSIGNMENT OF ANTITRUST ACTIONS.....	D-3
Article 9. TERMINATION BY COUNTY FOR CONVENIENCE	D-3
Article 10. TERMINATION BY COUNTY FOR CAUSE	D-4
Article 11. SUCCESS AND ASSIGNS.....	D-4
Article 12. REPORTING ACCIDENTS.....	D-4
Article 13. EMISSIONS REDUCTION.....	D-5
Article 14. WORKERS' COMPENSATION CERTIFICATION.....	D-5
Article 15. WARRANTY.....	D-5
Article 16. RETAINAGE	D-5
Article 17. DISADVANTAGED BUSINESS ENTERPRISE (DBE) PROGRAM	D-5
Article 18. PREVAILING WAGE REQUIREMENTS	D-5
Article 19. NONDISCRIMINATION	D-6
Article 20. CONTRACTOR ASSURANCES.....	D-6
Article 21. BUISNESS LICENSE	D-7
Article 22. TAXES	D-7
Article 23. CONTRACT ADMINISTRATOR.....	D-7
Article 24. AUTHORIZED SIGNATURES	D-7
Article 25. PARTIAL INVALIDITY	D-7
Article 26. NO THIRD PARTY BENEFICIARIES	D-7
Article 27. COUNTERPARTS	D-7
Article 28. ENTIRE AGREEMENT.....	D-7
CONTRACTOR'S BID AND BID PRICE SCHEDULE	D-9
PAYMENT BOND.....	NO PAGE NUMBER
PERFORMANCE BOND	NO PAGE NUMBER
PROPOSAL	P-1
PROPOSAL PAY ITEMS AND BID PRICE SCHEDULE.....	P-3
SUBCONTRACTOR LISTING.....	P-5
PUBLIC CONTRACT CODE SECTION 10285.1 STATEMENT.....	P-6
PUBLIC CONTRACT CODE SECTION 10162 QUESTIONNAIRE.....	P-7
PUBLIC CONTRACT CODE SECTION 10232 STATEMENT.....	P-7
NONCOLLUSION AFFIDAVIT	P-8
SIGNATURES.....	P-9
BIDDERS BOND	NO PAGE NUMBER

**COUNTY OF EL DORADO, CALIFORNIA
COMMUNITY DEVELOPMENT AGENCY
TRANSPORTATION DIVISION**

NOTICE TO BIDDERS

NOTICE IS HEREBY GIVEN by the County of El Dorado, State of California, that sealed bids for work in accordance with the Project Plans (Plans) and Contract Documents designated:

**PATTERSON DRIVE AND MISSOURI FLAT ROAD OVERLAYS
CONTRACT NO. PW 16-31119, CIP NO. 72190, P&C NO. 356-C1699**

will be received by the Clerk to the Board of Supervisors, at the Board of Supervisors Office, 330 Fair Lane, Placerville, California, until **June 29, 2016 at 2:00 PM**, at which time bids will be publicly opened and read by the County of El Dorado Community Development Agency, Transportation Division.

No Bid may be withdrawn after the time established for receiving bids or before the award and execution of the Contract, unless the award is delayed for a period exceeding sixty (60) calendar days. Bids must be executed in accordance with the instructions given and forms provided in the bound Contract Documents furnished by the County of El Dorado Community Development Agency, Transportation Division **through Quest Construction Data Network (Quest)**. **The Proposal including the Bidder's Security shall be submitted in a sealed envelope clearly marked:**

"PROPOSAL FOR PATTERSON DRIVE AND MISSOURI FLAT ROAD OVERLAYS"

CONTRACT NO. 16-31119, CIP NO. 72190, P&C NO. 356-C1699

TO BE OPENED AT 2:00 P.M. – ON JUNE 29, 2016

LOCATION/DESCRIPTION OF THE WORK: The Project is located along Patterson Drive between Lake Oaks Drive and Solstice Circle and along Missouri Flat Road between State Highway 49 and approximately seven hundred (700) feet north of State Highway 49, in Diamond Springs in County of El Dorado. The Work to be done is described in these Special Provisions, and generally consists of, but is not limited to:

- A. Bids consist of cold planing asphalt concrete, placement of geosynthetic material and hot mix asphalt on cold planed areas, and signal modifications. Other items or details not mentioned above, that are required by the Standard Plans, Standard Specifications, or these Special Provisions must be performed, constructed or installed.
- B. Bids are required for the entire Work described herein.
- C. The Contract time is twenty (20) WORKING DAYS.
- D. For bonding purposes the anticipated project cost is less than \$ 850,000.00.
- E. A pre-bid meeting is scheduled for this Project on **June 21, 2016 at 2:00 PM** at the County of El Dorado Community Development Agency, Transportation Division, 2441 Headington Road, Placerville, CA. The meeting will be held in the downstairs conference room. Attendance at the pre-bid meeting is not mandatory.
- F. This Project is being formally bid in accordance with Public Contract Code 22032 and County of El Dorado Ordinance Code section 3.14.040.

OBTAINING OR VIEWING CONTRACT DOCUMENTS: The Contract Documents, including the Project Plans, may be viewed and/or downloaded from the Quest website at <http://www.questcdn.com>. Interested parties may also access the Quest website by clicking on the link next to the Project Name or entering the Quest project # on the Community Development Agency, Transportation Division's website at <http://www.edcgov.us/Government//DOT/BidsHome.aspx>.

Interested parties may view the Contract Documents, including the Project Plans, on the Quest website at no charge. The digital Contract Documents, including the Project Plans, may be downloaded for \$10.00 by inputting the Quest project # 4244383 on the websites' Project Search page. Please contact QuestCDN.com at (925) 233-1632 or info@questcdn.com for assistance in free membership, registration, downloading, and working with this digital project information. To be included on the planholders list, receive notification of addenda, and to be eligible to bid interested parties must download the Contract Documents, including the Project Plans, from Quest. **Those downloading the Contract Documents assume responsibility and risk for completeness of the downloaded Contract Documents.**

The Contract Documents may be examined in person at the Community Development Agency Transportation Division office at 2850 Fairlane Court, Placerville CA. However the Community Development Agency Transportation Division will no longer sell paper copies of the Contract Documents.

The following Supplemental Project Information/Information Handout will be provided in pdf format as part of the Contract Documents on Quest's website to all planholders who acquire the Contract Documents digitally through Quest:

- 2010 Revised Standard Plans (RSP) A10B, A24A, A24E, A24F, T9, T12, T13, ES-1A, ES-1B, and ES-1C.
- Materials Laboratory Coring Results: Patterson Drive.

CONTRACTORS LICENSE CLASSIFICATION: Bidders must be properly licensed to perform the Work pursuant to the Contractors' State License Law (Business and Professions Code Section 7000 et seq.) and must possess a **CLASS A** license or equivalent combination of Classes required by the categories and type of Work included in the Contract Documents and Plans, at the time bids are submitted, and must maintain a valid license through completion and acceptance of the Work, including the guarantee and acceptance period. Failure of the successful Bidder to obtain proper adequate licensing will constitute a failure to execute the Contract and will result in the forfeiture of the Bidder's security.

BUSINESS LICENSE: The County Business License Ordinance provides that it is unlawful for any person to furnish supplies or services, or transact any kind of business in the unincorporated territory of County of El Dorado without possessing a County business license unless exempt under County Ordinance Code Section 5.08.070. The Bidder to whom an award is made must comply with all of the requirements of the County Business License Ordinance, where applicable, prior to beginning Work under this contract and at all times during the term of this contract.

CONTRACTOR REGISTRATION: No contractor or subcontractor may bid on any public works project, be listed in a bid proposal for any public works project, or engage in the performance of any contract for public work unless registered with the Department of Industrial Relations pursuant to Labor Code sections 1725.5 and 1771.1.

An inadvertent error in listing a subcontractor who is not registered pursuant to Section 1725.5 in a bid proposal shall not be grounds for filing a bid protest or grounds for considering the bid nonresponsive if the requirements of Labor Code section 1771.1 are met.

SUBCONTRACTOR LIST: Each Proposal must have listed therein the name, contractor's license number and address of each subcontractor to whom the bidder proposes to subcontract portions of the Work in an amount in excess of 0.5 % of the total bid or \$10,000, whichever is greater, in accordance with the Subletting and

Subcontracting Fair Practices Act, commencing with Section 4100 of the Public Contract Code. The Bidder must also describe in the Subcontractor List the work to be performed by each subcontractor listed. The work to be performed by the subcontractor must be shown by listing the bid item number, bid item description, and portion of the work to be performed by the subcontractor in the form of a percentage (not to exceed 100%) calculated by dividing the work to be performed by the subcontractor by the respective bid item amount(s) (not by the total bid price). The percentage of each bid item subcontracted may be submitted with the Bidder's bid or sent via email or fax to Jennifer Rimoldi, County of El Dorado Community Development Agency, Transportation Division, email-Jennifer.Rimoldi@edcgov.us, Fax-(530) 626-0387 by 4:00 p.m. on the first business day after the bid opening. The email or fax must contain the name of each subcontractor submitted with the Bidder's bid along with the bid item number, the bid item description, and the percentage of each bid item subcontracted, as described above. At the time bids are submitted, all listed subcontractors must be properly licensed to perform their designated portion of the work. The bidder's attention is directed to other provisions of the Act related to the imposition of penalties for failure to observe its provisions by using unauthorized subcontractors or by making unauthorized substitutions.

An inadvertent error in listing the California Contractor license number on the Subcontractor List will not be grounds for filing a bid protest or grounds for considering the bid non-responsive if the Bidder submits the corrected contractor's license number to Jennifer Rimoldi via fax or email as noted above within 24 hours after the bid opening, provided the corrected contractor's license number corresponds to the submitted name and location for that subcontractor.

NONDISCRIMINATION: Comply with Chapter 5 of Division 4 of Title 2, California Code of Regulations and the following.

**NOTICE OF REQUIREMENT FOR NONDISCRIMINATION PROGRAM
(GOVERNMENT CODE SECTION 12990)**

Comply with Section 7-1.021(2), "Nondiscrimination," of the Standard Specifications, which is applicable to all nonexempt State contracts and subcontracts, and to the "Standard California Nondiscrimination Construction Contract Specifications" set forth therein. The specifications are applicable to all nonexempt State construction contracts and subcontracts of \$5,000 or more.

PREVAILING WAGE REQUIREMENTS: In accordance with the provisions of California Labor Code Sections 1770 et seq., including but not limited to Sections 1773, 1773.1, 1773.2, 1773.6, and 1773.7, the general prevailing rate of wages in the county in which the Work is to be done has been determined by the Director of the California Department of Industrial Relations. Interested parties can obtain the current wage information by submitting their requests to the Department of Industrial Relations, Division of Labor Statistics and Research, PO Box 420603, San Francisco CA 94142-0603, Telephone (415) 703-4708 or by referring to the website at <http://www.dir.ca.gov/OPRL/PWD>. The rates at the time of the bid advertisement date of a project will remain in effect for the life of the project in accordance with the California Code of Regulations, as modified and effective January 27, 1997.

Copies of the general prevailing rate of wages in the county in which the Work is to be done are also on file at the Community Development Agency, Transportation Division's principal office, and are available upon request.

In accordance with the provisions of Labor Code 1810, eight (8) hours of labor constitutes a legal day's work upon all work done hereunder, and Contractor and any subcontractor employed under this Contract must conform to and be bound by the provisions of Labor Code Sections 1810 through 1815.

BID PROTEST PROCEDURE: The protest procedure is intended to handle and resolve disputes related to the bid award for this project pursuant to County of El Dorado policies and procedures

The protest procedure is an extension of the formal bid process and allows those who wish to protest the recommendation of an award after bid the opportunity to be heard.

Policy: Upon completion of the bid evaluation, the Community Development Agency, Transportation Division will notify all bidders of the recommendation of award, the basis therefore, and the date and time on which the recommendation for award will be considered and acted upon by the Board of Supervisors. All bidders may attend the Board of Supervisors meeting at the time the agenda item is considered, address the Board of Supervisors, and be heard.

Procedure: If a bidder wishes to protest the award, this is the procedure:

The Community Development Agency, Transportation Division will review the bids received in a timely fashion under the terms and conditions of the Notice to Bidders, and notify the bidders in writing, at the fax number designated in the Proposal, of its recommendation including for award or rejection of bids ("All Bidders Letter").

1. Within five (5) business days from the date of the "All Bidders Letter," the Bidder protesting the recommendation for award must submit a letter of protest to and must be received by the County of El Dorado, Community Development Agency, Transportation Division, Attention Jennifer Rimoldi, 2850 Fairlane Court,, Placerville, CA 95667, and state in detail the basis and reasons for the protest. The Bidder must provide facts to support the protest, including any evidence it wishes to be considered, together with the law, rule, regulation, or criteria on which the protest is based.
2. If Community Development Agency, Transportation Division finds the protest to be valid, it may modify its award recommendations and notify all bidders of that decision. If the Community Development Agency, Transportation Division does not agree with the protest, or otherwise fails to resolve the protest, the Community Development Agency, Transportation Division will notify the bid protestor and all interested parties of its decision and the date and time that the recommendation for award will be agendized for the Board of Supervisors' consideration and action. The Community Development Agency, Transportation Division will also include in its report to the Board of Supervisors the details of the bid protest.
3. The Bidder may attend the Board of Supervisors meeting at which the recommendation and bid protest will be considered. The Board of Supervisors will take comment from the Bidder, staff, and members of the public who wish to speak on the item. In the event that the Bidder is not in attendance at that time, the bid protest may be dismissed by the Board of Supervisors without further consideration of the merits; and

The decision of the Board of Supervisors on the bid protest will be final.

AWARD OF CONTRACT: Bids will be considered for award by the Board of Supervisors. The County of El Dorado reserves the right after opening bids to reject any or all bids, to waive any irregularity in a bid, or to make award to the lowest responsive, responsible Bidder and reject all other bids, as it may best serve the interests of the County.

As a condition of award, the successful Bidder will be required to submit bonds and evidence of insurance prior to execution of the Agreement by the County. Failure to meet this requirement constitutes abandonment of the Bid by the Bidder and forfeiture of the Bidder's security. Award will then be made to the next lowest, responsive, responsible Bidder.

RETAINAGE FROM PAYMENTS: The Contractor may elect to receive one hundred percent (100%) of payments due under the Contract from time to time, without retention of any portion of the payment by the County, by depositing securities of equivalent value with the County in accordance with the provisions of Section 22300 of the Public Contract Code. Securities eligible for deposit hereunder are be limited to those listed in Section 16430 of the Government Code, or bank or savings and loan certificates of deposit.

PROJECT ADMINISTRATION: Submit all Requests for Information (RFI) during the bid period on the Quest website under the Quest # 4244383 under "Project Q&A". If the response does not require an addendum, a response will be posted on the Quest website under the RFI under "Project Q&A". It is the bidders' responsibility

to check this website under "Project Q&A" for responses to bidders' inquiries during the bid period. Addenda will be uploaded in pdf format to Quest's website and Quest will issue an automatic email notification to all planholders that have acquired the Contract Documents digitally through Quest. The list of planholders will be available on Quest's website under "View Planholders".

No oral responses to any questions concerning the content of the Contract Documents will be given. All responses will be in the form of written addenda to the Contract Documents or written responses to bidders' inquiries. Responses to bidders' inquiries and addenda will be posted on the Quest website as described above **BY ORDER OF** the Director of the Community Development Agency, County of El Dorado, State of California.

Authorized by the Board of Supervisors on June 7, 2016, at Placerville, California.

By _____
Bard R. Lower, Transportation Division Director

By _____
Steven M. Pedretti, Community Development
Agency Director

ORGANIZATION

Special provisions are under headings that correspond with the main-section headings of the *Standard Specifications*. A main-section heading is a heading shown in the table of contents of the *Standard Specifications*.

Each special provision begins with a revision clause that describes or introduces a revision to the *Standard Specifications* as revised by any revised standard specification.

Any paragraph added or deleted by a revision clause does not change the paragraph numbering of the *Standard Specifications* for any other reference to a paragraph of the *Standard Specifications*.

STANDARD PLANS LIST

The standard plan sheets applicable to this Contract include those listed below. The applicable revised standard plans (RSPs) listed below are included in the project plans.

ABBREVIATIONS, LINES, SYMBOLS AND LEGEND

A10A	Abbreviations (Sheet 1 of 2)
RSP A10B	Abbreviations (Sheet 2 of 2)
A10C	Lines and Symbols (Sheet 1 of 3)
A10D	Lines and Symbols (Sheet 2 of 3)
A10E	Lines and Symbols (Sheet 3 of 3)

PAVEMENT MARKERS, TRAFFIC LINES, AND PAVEMENT MARKINGS

A20A	Pavement Markers and Traffic Lines, Typical Details
A20B	Pavement Markers and Traffic Lines, Typical Details
A20D	Pavement Markers and Traffic Lines, Typical Details
RSP A24A	Pavement Markings – Arrows
A24B	Pavement Markings - Arrows and Symbols
A24D	Pavement Markings – Words
RSP A24E	Pavement Markings - Words, Limit and Yield Lines
RSP A24F	Pavement Markings – Crosswalks

TEMPORARY TRAFFIC CONTROL SYSTEMS

- RSP T9 Traffic Control System Tables for Lane and Ramp Closures**
- RSP T12 Traffic Control System for Half Road Closure on Multilane Conventional Highways and Expressways**
- RSP T13 Traffic Control System for Lane Closure on Two Lane Conventional Highways**

ELECTRICAL SYSTEMS - LEGEND AND ABBREVIATIONS

- RSP ES-1A Electrical Systems (Legend and Abbreviations)**
- RSP ES-1B Electrical Systems (Legend and Abbreviations)**
- RSP ES-1C Electrical Systems (Legend and Abbreviations)**

ELECTRICAL SYSTEMS - DETECTORS

- RSP ES-5D Electrical Systems (Curb Termination and Handhole)**



DIVISION I GENERAL PROVISIONS

1 GENERAL

Add to section 1-1.01:

Bid Items and Applicable Sections

Item code	Item description	Applicable section
128651A	PORTABLE CHANGEABLE MESSAGE SIGN	12
149001A	PREPARE FUGITIVE DUST CONTROL PLAN	14
152438A	ADJUST FRAME AND COVER TO GRADE (WATER VALVE)	15
152438B	ADJUST FRAME AND COVER TO GRADE (MANHOLE)	15
153103A	COLD PLANE ASPHALT CONCRETE PAVEMENT (CONFORM GRIND)	15
153103B	COLD PLANE ASPHALT CONCRETE PAVEMENT (PROFILE GRIND)	15

Replace the corresponding definitions in section 1-1.07B with:

Bid Item List: List of bid items and the associated quantities. The Proposal Pay Items and Bid Price Schedule in the Proposal section is the Bid Item List. The verified Bid Item List is Exhibit A Contractor's Bid and Bid Price Schedule in the fully-executed contract for the project.

Contract acceptance: County Clerk/Recorder's recordation of the executed written Notice of Acceptance of a completed Contract.

Add to section 1-1.07B:

Contract approval: Execution of the Contract by the County of El Dorado.

Contract award package: The Notice of Award of Contract letter, two originals of the Agreement, Payment and Performance bond forms, and other forms the successful Bidder must complete for Contract Execution.

Contract Documents: See Article 2 "Contract Documents" of the Draft Agreement.

County: County of El Dorado, a political subdivision of the State of California.

Replace the corresponding definitions in section 1-1.07B with:

Department or Department of Transportation: The Transportation Division in the Community Development Agency of the County of El Dorado or Department of Transportation as defined in St & Hwy Code § 20 and authorized in St & Hwy Code § 90; its authorized representatives.

Engineer– The Director of Transportation for County of El Dorado, or authorized representative (Resident Engineer) responsible for the Contract's administration; the Resident Engineer's authorized representatives.

Delete estimated cost in section 1-1.07B.

Add to section 1-1.07B:

EID: El Dorado Irrigation District

Replace informal-bid contract in section 1-1.07B with:

Informal-bid contract: Contract that is noted as informally bid in the Notice to Bidders.

Add to section 1-1.07B:

Laboratory: The established laboratory of the County of El Dorado Department of Transportation or laboratories authorized by the Engineer to test materials and work involved in the contract.

Office Engineer: The Office Engineer in the County of El Dorado Community Development Agency, Transportation Division or, depending on context, Caltrans Office Engineer

Proposal: The Proposal section of the Contract Documents book, or the Bidder's bid.

Replace the corresponding definitions in section 1-1.07B with:

2. revised standard specifications: New or revised standard specifications. These specifications are in a section titled Revised Standard Specifications of a book titled Contract Documents including Notice to Bidders, Special Provisions, Proposal, and Contract.

3. special provisions: Specifications specific to the project. These specifications are in a section titled Special Provisions of a book titled Contract Documents including Notice to Bidders, Special Provisions, Proposal, and Contract.

State: The State of California, including its agencies, departments, or divisions, whose conduct or action is related to the work, or County of El Dorado, a political subdivision of the State, and its Community Development Agency, Transportation Division

Structure Design: The Department of Transportation for County of El Dorado or Offices of Structure Design of the Department of Transportation.

Add to section 1-1.11

Reference or agency or department unit	Web site	Address	Telephone no.
County of El Dorado Department of Transportation	http://www.edcgov.us/DOT/	2850 Fairlane Court Placerville, CA 95667	
County of El Dorado Department of Transportation Office Engineer		2850 Fairlane Court Placerville, CA 95667	(530) 621-7592

Replace section 1-1.12 with:

Make checks payable to County of El Dorado. Use the bond forms provided in the book titled Contract Documents including Notice to Bidders, Special Provisions, Proposal, and Contract.

~~~~~

**2 BIDDING**

Delete the 2nd paragraph of section 2-1.01 of the RSS dated 2-21-14.

**Replace section 2-1.06A of the RSS dated 1-23-15 with:**

The Contract Documents book and project plans may be viewed by subscribers at:

1. El Dorado Builders' Exchange at [www.goodbuilders.org](http://www.goodbuilders.org)
2. Mc Graw-Hill Construction Dodge at [www.fwdodge.com](http://www.fwdodge.com)
3. Construction Bid Board at [www.ebidboard.com](http://www.ebidboard.com)

Quest Construction Data Network's website as described in the Notice to Bidders. The Notice to Bidders can be viewed at <http://www.edcgov.us/Government/DOT/BidsHome.aspx>

The Notice to Bidders includes how and where to obtain the Contract Documents book, the project Plans, and the Supplemental Project Information.

The Contract Documents book includes the Notice to Bidders, revised standard specifications, special provisions, Proposal, and Contract.

**Replace the 3<sup>rd</sup> paragraph of section 2-1.06B of the RSS dated 10-17-14 with:**

If an Informational Handout or cross sections are available you may view and/or download them at as described in the Notice to Bidders

**Add to section 2-1.06B:**

Availability of and requests for rock cores, other supplemental project information, and bridge as-built drawings described in this section apply only to projects on the State Highway System.

**Add to section 2-1.06B:**

The Department makes the Revised Standard Plans and the Materials Laboratory Coring Results: Patterson Drive, as specified in the Notice to Bidders, available as the supplemental project information.

**Replace the 2<sup>nd</sup> paragraph of section 2-1.10 in the RSS dated 2-27-15 with:**

The Subcontractor List in the Proposal must show the name, contractor's license number, address and work portions to be performed by each subcontractor listed. The work portion to be performed must be shown by listing the bid item number, bid item description, and portion of the work to be performed by the subcontractor in the form of a percentage (not to exceed 100%) calculated by dividing the work to be performed by the subcontractor by the respective bid item amount(s) (not by the total bid price).

An inadvertent error in listing the California Contractor license number on the Subcontractor List will not be grounds for filing a bid protest or grounds for considering the bid non-responsive if the Bidder submits the corrected contractor's license number to Jennifer Rimoldi via fax (530) 626-0387 or email Jennifer.Rimoldi@edcgov.us within 24 hours after the bid opening, provided the corrected contractor's license number corresponds to the submitted name and location for that subcontractor.

**Replace section 2-1.15 "Disabled Veterans Business Enterprise" with:**

**2-1.15 RESERVED**

**Replace section 2-1.18 "Small Business and Non-Small Business Subcontractor Preferences" with:**

**2-1.18 RESERVED**

**Replace section 2-1.27 "California Companies" with:**

**2-1.27 RESERVED**

**Replace section 2-1.33 of the RSS dated 2-27-15 with:**

Except as noted below, complete the pages of the Proposal in the Contract Documents book and submit the completed Proposal with the Bidder's Security as noted in the Notice to Bidders.

Submit the forms from the Proposal and form information at the times shown in the following table:

| Contract type                                                                                                                                                                                                                                                                                                                                                                                                                                                                                                                                                                                                                                                                      | Forms to be submitted at the time of bid                                                                                                         | Forms to be submitted and received no later than 24 hours after bid opening <sup>a</sup>                                                                                                                                                                                                                                  | Forms to be submitted and received no later than 4 p.m. on the 4th business day after bid opening <sup>a</sup>                                                                              |
|------------------------------------------------------------------------------------------------------------------------------------------------------------------------------------------------------------------------------------------------------------------------------------------------------------------------------------------------------------------------------------------------------------------------------------------------------------------------------------------------------------------------------------------------------------------------------------------------------------------------------------------------------------------------------------|--------------------------------------------------------------------------------------------------------------------------------------------------|---------------------------------------------------------------------------------------------------------------------------------------------------------------------------------------------------------------------------------------------------------------------------------------------------------------------------|---------------------------------------------------------------------------------------------------------------------------------------------------------------------------------------------|
| All contracts                                                                                                                                                                                                                                                                                                                                                                                                                                                                                                                                                                                                                                                                      | All Proposal forms including Business name and address; bid item number and bid item description of subcontracted work on the Subcontractor List | <ul style="list-style-type: none"> <li>• Subcontractor name bid item number, bid item description shown on the Subcontractor List submitted with Proposal, and the percentage of each bid item <sup>b</sup></li> </ul> <p>Correction for incorrect Contractor License # on Subcontractor List submitted with Proposal</p> | --                                                                                                                                                                                          |
| Federal-aid contracts only                                                                                                                                                                                                                                                                                                                                                                                                                                                                                                                                                                                                                                                         |                                                                                                                                                  | --                                                                                                                                                                                                                                                                                                                        | <ul style="list-style-type: none"> <li>• Local Agency Bidder - DBE – Commitment (Exhibit 15-G)</li> <li>• DBE Information-Good Faith Efforts (Exhibit 15-H) and Documentation c-</li> </ul> |
| <p><sup>a</sup> The percentage of each bid item and the 15-G and 15-H forms may be submitted at the time of bid.</p> <p><sup>b</sup> If the information is not submitted at the time of bid email or fax to Office Engineer, email-Jennifer.Rimoldi@edcgov.us, Fax-(530) 626-0387. This after-bid submittal does not apply to an informal-bid contract. For an informal bid contract, submit the completed form at the time of bid.</p> <p><sup>c</sup> If not submitted at the time of bid, applicable only to the apparent low bidder, 2nd low bidder, and 3rd low bidder. Submit via email or fax to Office Engineer, email-Jennifer.Rimoldi@edcgov.us, Fax-(530) 626-0387.</p> |                                                                                                                                                  |                                                                                                                                                                                                                                                                                                                           |                                                                                                                                                                                             |

Failure to submit the forms and information as specified results in a nonresponsive bid.

If an agent other than the authorized corporation officer or a partnership member signs the bid, submit a Power of Attorney authorizing the agent to sign on behalf of the principal with the bid. Otherwise, the bid may be disregarded as irregular or unauthorized.

**Replace the 4<sup>th</sup> item of the 1<sup>st</sup> paragraph of section 2-1.34 with:**

4. Bidder's bond signed by an authorized representative of a surety insurer who is licensed in California. The authorized representative's signature must be notarized and authorization documentation must be provided.

**Delete the 5th item of the 1<sup>st</sup> paragraph of section 2-1.34 of the RSS dated 2-21-14.**

**Replace the last paragraph of section 2-1.34 with:**

If using a bidders bond, you must complete the Bidder's bond form included in in the Contract Documents following the Proposal and submit it with your proposal.

**Replace "Reserved" in the RSS dated 2-21-14 for section 2-1.35 with:**

If applicable, submit proof of each required SSPC QP certification with your Proposal. Failure to do so results in a non-responsive bid.

**Replace section 2-1.40 in the RSS dated 2-21-14 with:**

An authorized agent may withdraw a bid before the bid opening date and time by submitting a written bid withdrawal request at the location where the bid was submitted. Withdrawing a bid does not prevent you from submitting a new bid.

After the bid opening time, you cannot withdraw a bid.

**Replace "Reserved" in section 2-1.44 with:**

The protest procedure is intended to handle and resolve disputes related to the bid award for this project pursuant to County policies and procedures.

The protest procedure is an extension of the formal bid process and allows those who wish to protest the recommendation of an award after bid the opportunity to be heard.

**Policy:** Upon completion of the bid evaluation, the Department will notify all bidders of the recommendation of award, the basis therefore, and the date and time on which the recommendation for award will be considered and acted upon by the Board of Supervisors. All bidders may attend the Board of Supervisors meeting at the time the agenda item is considered, address the Board of Supervisors, and be heard.

**Procedure:** If you wish to protest the award, this is the procedure:

1. The Department will review the bids received in a timely fashion under the terms and conditions of the Notice to Bidders, and notify you in writing, at the fax number designated in the Proposal, of its recommendation including for award or rejection of bids ("All Bidders Letter").
2. Within five (5) business days from the date of the "All Bidders Letter," the Bidder protesting the recommendation for award must submit a letter of protest to and must be received by Office Engineer, Attention Jennifer Rimoldi, and state in detail the basis and reasons for the protest. The Bidder must provide facts to support the protest, including any evidence it wishes to be considered, together with the law, rule, regulation, or criteria on which the protest is based.
3. If the Department finds the protest to be valid, it may modify its award recommendations and notify all bidders of that decision. If the Department does not agree with the protest, or otherwise fails to resolve the protest, the Department will notify the bid protestor and all interested parties of its decision and the date and time that the recommendation for award will be agendized for the Board of Supervisors' consideration and action. The Department will also include in its report to the Board of Supervisors the details of the bid protest.

4. The Bidder may attend the Board of Supervisors meeting at which the recommendation and bid protest will be considered. The Board of Supervisors will take comment from the Bidder, staff, and members of the public who wish to speak on the item. If the Bidder is not in attendance at that time, the bid protest may be dismissed by the Board of Supervisors without further consideration of the merits; and

The decision of the Board of Supervisors on the bid protest will be final.

**Replace the 1<sup>st</sup> sentence in section 2-1.46 with:**

County Board of Supervisors' decision on the bid award is final.

**Replace the 1<sup>st</sup> sentence in the 2<sup>nd</sup> paragraph section 2-1.46 with:**

County Board of Supervisors may reject:

**Replace section 2-1.47 with:**

**2-1.47 BID RELIEF**

County Board of Supervisors may grant bid relief under Pub Cont Code § 5100 et seq. Submit any request for bid relief to Office Engineer, email-Jennifer.Rimoldi@edcgov.us, Fax-(530) 626-0387. Requests for bid relief must be in writing within 5 business day of the bid opening and must demonstrate:

1. A mistake was made in your bid.
2. The mistake made the bid materially different than what you intended.
3. The mistake was made in filling out the bid and not due to an error in judgment or to carelessness in inspecting the site of work or in reading the plans or specifications.

**Delete section 2-1.49.**



**3 CONTRACT AWARD AND EXECUTION**

**Replace section 3-1.02B of the RSS dated 2-21-14 with:**

The Department breaks a tied bid with a coin toss.

**Delete the 1<sup>st</sup> paragraph of section 3-1.04.**

**Replace the 2<sup>nd</sup> and 3<sup>rd</sup> paragraphs of section 3-1.04 with:**

County Board of Supervisors will consider bids for award. County reserves the right after opening bids to reject any or all bids, to waive any irregularity in a bid, or to make award to the lowest responsive, responsible Bidder and reject all other bids, as it may best serve the interests of County. The award of the Contract, if it be awarded, will be to the lowest, responsive, responsible bidder whose Proposal complies with all the requirements prescribed. This award, if made, will be made within sixty (60) days after the opening of the bids. This period will be subject to extension as may be agreed upon in writing between the Department and the Bidder concerned.

All bids will be compared on the basis of the Proposal Pay Items and Bid Price Schedule of the quantities of work to be done.

The lowest, responsive, responsible bidder will be the Bidder submitting the lowest additive total of all the bid items and meeting all other requirements. In the event of a discrepancy between the unit price bid and the extended unit total as stated on the Proposal, the Department uses the amount bid for the unit price in calculating the additive total of the bid items for purposes of award, including revisions by Addenda, and as specified in the Proposal instructions.

**Delete the paragraph added to the end of section 3-1.04 in the RSS dated 10-19-12.**

**Replace section 3-1.05 with:**

**3-1.05 CONTRACT BONDS (PUB CONT CODE § 7103)**

The successful Bidder must furnish two bonds:

- 1) Payment bond to secure the claim payments of laborers, workers, mechanics, or materialmen providing goods, labor, or services under the Contract. This bond must be in a sum not less than one hundred percent (100%) of the total amount payable by the terms of the contract, naming the County as obligee.
- 2) Performance bond to guarantee faithful performance of the Contract. This bond must be in a sum not less than one hundred percent (100%) of the total amount payable by the terms of the contract, naming the County as obligee.

The Payment and Performance Bond forms are included with the Draft Agreement section of the Contract Documents book. The Department furnishes the successful Bidder bond forms with the Contract award package.

**Delete the 1<sup>st</sup> paragraph of section 3-1.06.**

**Replace the 1<sup>st</sup> item of the 2<sup>nd</sup> paragraph of section 3-1.06 with:**

1. The Contractor must be properly licensed as a contractor from bid opening (Bus & Prof Code § 7028.15) through completion and acceptance of the Work, including the guarantee period. Failure to obtain proper and adequate licensing constitutes a failure to execute the Contract and results in the forfeiture of the security of the bidder.

**Replace section 3-1.08 “Small Business Participation Report” with:**

**3-1.08 RESERVED**

**Replace section 3-1.11 with:**

**3-1.11 COUNTY PAYEE DATA RECORD FORM**

Complete and sign the County Payee Data Record form included in the Contract award package.

**Replace section 3-1.18 with:**

**3-1.18 CONTRACT EXECUTION**

The successful Bidder must sign the Agreement.

Deliver to Office Engineer:

1. Two Original Signed Agreements

2. Contract Bonds
3. Documents identified in section 3-1.07 and 7-1.06
4. County Payee Data Record form
5. California Form 590-Withholding Exemption Certificate
6. Documents identified in and marked as specified in section 3-1.14, if applicable.

Office Engineer must receive these documents within the 10 business days of the date of the Notice of Award of Contract letter.

The Bidder's security may be forfeited for failure to execute the Contract, furnish any bond, or provide the required insurance documents within the time specified.

The Department does not provide hard copies of the Contract Documents, including the Project Plans to the successful bidder.

**Replace section 3-1.19 with:**

**3-1.19 BIDDERS' SECURITIES (Pub Cont Code § 20129)**

The Department returns the securities of the unsuccessful Bidders within 60 days Contract award. The Department returns the successful Bidder's security within 60 days of Contract execution.



**4 SCOPE OF WORK**

**Delete section 4-1.07C.**



**5 CONTROL OF WORK**

**Replace the 5<sup>th</sup> paragraph of section 5-1.01 with:**

Ensure the Department's, Caltrans, and El Dorado Irrigation District's safe access to the work. Furnish facilities necessary for the Department's, Caltrans, and El Dorado Irrigation District's inspection.

**Delete section 5-1.09.**

**Replace the 6<sup>th</sup> paragraph of section 5-1.13A with:**

Each subcontract must include the provisions of this contract and each subcontractor must comply with the applicable terms and conditions of this contract.

**Replace the 7<sup>th</sup> paragraph of section 5-1.13A with:**

The Department encourages you to and, for USDOT federal-aid assisted projects, you must include a dispute resolution process in each subcontract.

**Replace section 5-1.13C "Disabled Veterans Business Enterprise" with:**



**5-1.13C RESERVED**

**Replace section 5-1.13D “Non-Small Business” with:**

**5-1.13D RESERVED**

**Add to section 5-1.20B(1):**

The Department has obtained a State of California Encroachment Permit prior to construction. A copy of the permit can be obtained from the Engineer through a written request.

Before beginning work within state right of way obtain a State of California Encroachment permit from:

CALTRANS, DISTRICT 3  
PERMIT ENGINEER  
703 B Street  
Marysville, CA 95901  
(530) 741-4403

In accordance with section 9-1.03, “Payment Scope”, full compensation for obtaining the State of California Encroachment permit is included in the payment for the various items of work.

You must comply with the conditions of the State of California Encroachment permit.

Payment for complying with the State of California Encroachment is included in the various items of work.

**Replace section 5-1.20B(4) with:**

Before procuring material, disposing of material, or otherwise using non-highway property, obtain a written agreement from the property owner.

**Replace “Reserved” in section 5-1.20F with:**

**5-1.20F COORDINATION WITH SCHOOLS**

You must provide written notice to the following schools and school district at least one (1) week prior to any lane closures, detour, construction staging or any work that may affect traffic or pedestrians through the construction area:

**Union Mine High School**

6530 Koki Lane  
El Dorado, CA 95623  
Principal: Paul Neville  
(530) 621-4003

**Independence High School**

385 Pleasant Valley Road  
Diamond Springs, CA 95619  
Principal: Alison Gennai  
(530) 622-7090

**El Dorado Union High School District**

4675 Missouri Flat Road  
Placerville, CA 95667  
(530) 622-5081

**Mother Lode Union School District**

3783 Forni Road  
Placerville, CA 95667  
(530) 622-6464

**Replace section 5-1.21 with:**

**5-1.21 COORDINATION WITH PROPERTY OWNERS**

You must make every effort to communicate with adjacent property owners and tenants to inform them of required access for construction operations, and must give forty-eight (48) hours' notice to the property owners and tenants when work is to be performed on their property.

Access to adjacent businesses must be maintained so that the businesses will remain open during all normal business hours.

**Replace item 2 of the 2<sup>nd</sup> paragraph of section 5-1.26 with:**

2. On a Request for Construction Staking form.

**Add item 3 to the 1<sup>st</sup> paragraph of section 5-1.27B:**

3. All other pending matters under this Contract are closed.

**Replace the opening phrase of the 2<sup>nd</sup> paragraph of section 5-1.27B with:**

For at least 4 years after the later of these, retain cost records, including records of:

**Replace Section 5-1.27C with:**

**5-1.27C Record Inspection, Copying, and Auditing**

Make your records available for inspection, copying, and auditing by representatives of the County, the State Auditor, or their duly authorized representatives, and any duly authorized representative of other government agencies for the same time frame specified under section 5-1.27 B. The records of subcontractors and suppliers must be made available for inspection, copying, and auditing by representatives of the County, the State Auditor, or their duly authorized representatives, and any duly authorized representative of other government agencies for the same period. Make records available for examination during normal business hours at your principal place of business in California, for audit during normal business hours at this place of business. Provide office space, photocopies and other assistance to enable audit or inspection representatives to conduct these audits or inspections.

Incorporate this provision in any subcontract entered into as a result of this Contract. Require subcontractors to agree to cooperate with the listed agencies by making all appropriate and relevant Project records available to those agencies for audit and copying.

**Replace section 5-1.27E with:**

**5-1.27E Change Order Bills**

Maintain separate records for change order work costs. Submit paper copy change order bills.

**Delete the 2<sup>nd</sup> and 3<sup>rd</sup> paragraphs of section 5-1.32**

**Add to the 3<sup>rd</sup> paragraph of section 5-1.36D.**

Underground Service Alert Phone: 811

**El Dorado Irrigation District (EID)**

Main # 24 hr: (530) 622-4513  
Mike Brink - Sr. Civil Engineer  
(530) 642-4054  
Skip Haskell – Inspector  
(530) 642-4120  
Fax (530) 642-4079  
4079 Mosquito Road  
Placerville, CA 95667

**Comcast**

Ron Chacon  
Sefnco Communications  
(916) 584-6648  
Fax (916) 288-9954  
8583 Elder Creek Rd.  
Sacramento, CA 95828

**CVIN**

Barbara Nelson  
(559) 554-9119  
Fax (559) 442-6047

**Pacific Gas and Electric Company**

24 Hr # (800) 743-5000  
Jennifer Donovan  
(530) 621-7228  
(530) 383-0973  
4636 Missouri Flat Road  
Placerville, CA 95667

**AT&T**

24 Hr # (866) 346-1168  
Astrid Willard  
(916) 484-2388  
Fax (916) 451-8504  
3675 T Street Room 170  
Sacramento, CA 95816-6648

**Replace the 1<sup>st</sup> and 2<sup>nd</sup> sentence of the 2<sup>nd</sup> paragraph of section 5-1.46 with:**

When the Engineer determines that the work is complete, the Engineer recommends to the Board of Supervisors that the contract be accepted and the Notice of Acceptance be recorded to accept the contract. Immediately after the acceptance by the Board of Supervisors, you are relieved from:

~~~~~

6 CONTROL OF MATERIALS

Delete the RSS dated 4-19-13 for section 6-2.05C.

Replace the 1st sentence of the 3rd paragraph of section 6-3.05C with:

The Department provides an inspection request form and procedures for its submittal.

Replace the 3rd paragraph of section 6-3.05G with:

Submit material to be tested with a *Sample Identification Card* provided by the Department.

~~~~~

**7 LEGAL RELATIONS AND RESPONSIBILITY TO THE PUBLIC**

**Replace section 7-1.02C “Emission Reduction” with:**

**Section 7-1.02C Emission Reduction**

Sign the Emissions Reduction Certification in the Article 13 “Emission Reduction” of the Agreement.

**Replace item 1 of the 2<sup>nd</sup> paragraph of section 7-1.02K(2) with:**

1. At the County of El Dorado Community Development Agency Transportation Division's principal office, and are available upon request.

**Delete paragraphs 5 through 9 of section 7-1.02K(3).**

**Add to section 7-1.02K(4)**

It is County policy to encourage the employment and training apprentices on public works contracts as may be allowed under local apprenticeship standards.

**Replace the 14<sup>th</sup> paragraph of section 7-1.04 with:**

Notify the Engineer as soon as practical before the anticipated start of an activity that will change the vertical or horizontal clearance available to traffic, including shoulders. Caltrans will be notified that the change in the horizontal clearance to traffic will be in place for the duration of the contract.

**Replace section 7-1.05 "Indemnification" with:**

**7-1.05 INDEMNIFICATION**

Comply with Article 5 "Indemnity" of the Agreement.

**Replace section 7-1.06 "Insurance" with:**

**7-1.06 INSURANCE**

**7-1.06A General Insurance Requirements**

County will not execute this Contract and you are not entitled to any rights, unless certificates of insurances, or other sufficient proof satisfactory to County of El Dorado Risk Management Division that the following provisions have been complied with, and these certificate(s) are filed with the County.

Without limiting your indemnification required by Article 5 "Indemnity" of the Draft Agreement, you must procure and maintain and must require any of your subcontractors to procure and maintain for the duration of the Contract, including the one-year guarantee period, insurance against claims for injuries to persons or damages to property which may arise from or in connection with the performance of the work hereunder and the results of that work by you, your agents, representatives, employees or subcontractors. Coverage must be at least as broad as:

Workers' Compensation as required by law in the State of California, with Statutory Limits, and Employer's Liability Insurance with a limit of no less than \$1,000,000 per accident for bodily injury or disease.

Commercial General Liability Insurance of not less than Four Million Dollars (\$4,000,000) aggregate limit and Two Million Dollars (\$2,000,000) combined single limit per occurrence for bodily injury and property damage, including but not limited to endorsements for the following coverage: Premises, personal injury, operations, products and completed operations, blanket contractual, and independent contractors liability. This insurance can consist of a minimum \$2 Million primary layer of CGL and the balance as an excess/umbrella layer, but only if the County is provided with written confirmation that the excess/umbrella layer "follows the form" of the CGL policy.

Automobile Liability Insurance of not less than One Million Dollars (\$1,000,000) is required in the event motor vehicles are used by the Contractor in performance of the Contract.

In the event Contractor is a licensed professional and is performing professional services under this Contract, Professional Liability Insurance is required with a limit of liability of not less than One Million Dollars (\$1,000,000).

Explosion, Collapse and Underground coverage is required when the scope of work includes XCU exposures. For the purpose of this Contract, XCU coverage is required.

#### **7-1.06B Proof of Insurance Requirements**

Furnish proof of coverage satisfactory to the County of El Dorado Risk Management Division as evidence that the insurance required herein is being maintained. The insurance must be issued by an insurance company acceptable to the Risk Management Division, or be provided through partial or total self-insurance likewise acceptable to the Risk Management Division.

The County of El Dorado, its officers, officials, employees, and volunteers must be included as additional insureds, but only insofar as the operations under this Contract are concerned. This provision applies to all general liability and excess liability policies. Proof that the County is named additional insured must be made by providing the Risk Management Division with a certified copy, or other acceptable evidence, of an endorsement to your insurance policy naming the County additional insured.

If you cannot provide an occurrence policy, provide insurance covering claims made as a result of performance of this Contract for not less than three (3) years following completion of performance of this Contract.

Any deductibles or self-insured retentions must be declared to and approved by the County. At the option of the County, either: the insurer must reduce or eliminate such deductibles or self-insured retentions as respects the County, its officers, officials, employees and volunteers; or the Contractor must procure a bond guaranteeing payment of losses and related investigations, claim administration and defense expenses.

Require each of your subcontractors to procure and maintain commercial general liability insurance, automobile liability insurance, and workers compensation insurance of the types and in the amounts specified above, or you must insure the activities of your subcontractors in your policy in like amounts. You must also require each of your subcontractors to name you and County of El Dorado, its officers, officials, employees, and volunteers as additional insureds.

#### **7-1.06C Insurance Notification Requirements**

You agree no cancellation or material change in any policy will become effective except upon prior written notice to the Community Development Agency, Contract Services Unit, 2850 Fairlane Court, Placerville, CA 95667.

You agree that the insurance required herein will be in effect at all times during the term of this Contract. If this insurance coverage expires at any time or times during the term of this Contract, you must immediately provide a new certificate of insurance as evidence of the required insurance coverage. If you fail to keep in effect at all times insurance coverage as herein provided, County may, in addition to any other remedies it may have, terminate this Contract upon the occurrence of this event. New certificates of insurance are subject to the approval of the Risk Management Division.

#### **7-1.06D Additional Standards**

Certificates must meet such additional standards as may be determined by the Department either independently or in consultation with the Risk Management Division, as essential for protection of the County.

#### **7-1.06E Commencement of Performance**

Contractor must not commence performance of this Contract unless and until compliance with every requirement of the insurance provisions is achieved.

**7-1.06F Material Breach**

Failure to maintain the insurance required herein, or to comply with any of the requirements of the insurance provisions, constitutes a material breach of the entire Contract.

**7-1.06G Reporting Provisions**

Any failure to comply with the reporting provisions of the policies must not affect coverage provided to the County, its officers, officials, employees or volunteers.

**7-1.06H Primary Coverage**

Your insurance coverage must be primary insurance as respects the County, its officers, officials, employees and volunteers. Any insurance or self-insurance maintained by the County, its officers, officials, employees or volunteers will be in excess of your insurance and will not contribute with it.

**7-1.06I Premium Payments**

The insurance companies will have no recourse against the County of El Dorado its officers, agents, employees, or any of them for payment of any premiums or assessments under any policy issued by any insurance company.

**7-1.06J Contractor’s Obligations**

Your indemnity and other obligations are not limited by the insurance required herein and must survive the expiration of this Contract.



**8 PROSECUTION AND PROGRESS**

**Replace item 2.1 of the list in the 3<sup>rd</sup> paragraph of section 8-1.02B(2) with:**

Contract number and CIP number

**Replace item 8 of section 8-1.02B(2) with:**

- 1. Start milestone date as Notice of Award letter date

**Replace the 1<sup>st</sup> and last sentences of the 1<sup>st</sup> paragraph of section 8-1.03 with:**

At the Construction Division Office, 2441 Headington Road, Placerville, attend a pre-construction conference with key personnel, including all major superintendents for the work and major subcontractors. The pre-construction conference will be scheduled after the project is awarded and prior to the issuance of the Notice to Proceed. At this conference, submit in writing, signed by the officers of the corporation, if applicable, the names of two employees who will be the superintendents on the project. The second name serves as an alternate in the absence of the first designee. The superintendent must be on the site at all times that work is in progress.

With the exception of preparing and obtaining Department’s authorization of the Storm Water Pollution Prevention Plan (SWPPP), or Water Pollution Control Program (WPCP), whichever is applicable, and preparing and obtaining Department’s acceptance of the Critical Path Method (CPM) baseline schedule, any work performed in advance of the date stated in the Notice to Proceed is at your risk and as a volunteer. Submit a completed Subcontracting Request form, Exhibit 16-B of the Caltrans Local Assistance Procedures Manual (LAPM), or equivalent and obtain approval before beginning work on a subcontract. Comply with applicable parts of section 5-1.13B(1).

**Delete “Partnering” from the table in section 8-1.03.**

**Add to section 8-1.03.**

You must attend weekly meetings to discuss construction issues and scheduling.

**Replace section 8-1.04B with:**

The contract working days begin on the date stated in the Notice to Proceed.

The Engineer will issue Notice to Proceed 10 days after Contract approval.

Do not start job site activities until the Department authorizes or accepts your submittal for:

1. CPM baseline schedule
2. WPCP
3. Traffic Control Plan
4. Solid Waste Diversion and Recycling Plan
5. Fugitive Dust Control Plan submitted to AQMD
6. Lead Compliance Plan & Work Plan

You may enter the job site only to measure controlling field dimensions and locating utilities.

Do not start other job site activities until all the submittals from the above list are authorized or accepted and the following information is received by the Engineer:

1. Notice of Materials to Be Used.
2. Contingency plan for reopening closures to public traffic.
3. AQMD approved Fugitive Dust Control Plan (prior to starting work that generates dust).

**Replace the 1<sup>st</sup> paragraph of section 8-1.05 with:**

Contract time starts on the day specified in section 8-1.04B.

Contract working hours for work being performed on Patterson Drive are between the hours of 7:00 a.m. to 7:00 p.m. unless otherwise authorized. Refer to Chart number 1 in section 12-4.05F of these Special Provisions.

Contract working hours for work being performed on Missouri Flat Road are between the hours of 8:00 p.m. to 6:00 a.m. unless otherwise authorized. Refer to Chart number 2 and 3 in section 12-4.05F of these Special Provisions.

**Add to the end of section 8-1.06 as revised by the RSS:**

The Engineer may suspend work due to environmental permit restrictions and/or inclement weather.

During the suspension, the Department pays for winterization costs or costs associated with water pollution control within the County's project area under section 13-2.04 or 13-3.04, as applicable. The Department pays for any other contract work required to be performed within the County's project area during the suspension under the applicable bid item.

**Add to section 8-1.10B:**

Liquidated damages for not completing the work within twenty (20) working days is \$1,900 per day.

**Delete the revision made to section 8-1.10D in the RSS.**

**Replace section 8-1.13 "Contractor's Control Termination" with:**

Refer to Article 10 "Termination By County for Cause" of the Agreement.

**Replace section 8-1.14 "Contract Termination" with:**

Refer to Article 9 "Termination By County for Convenience" of the Agreement.

^^^^^^^^^^^^^^^^^^^^^^^^^^^^^^^^^^^^^^^^^^^^^^^^^^^^^^^^^^^^

**9 PAYMENT**

**Add to end of section 9-1.03:**

The Department pays 6 percent annual interest for the period of the retention for penalty withholds later determined not owed.

**Delete "Replace "10" in the last paragraph of section 9-1.03 with:" in the RSS dated 1-23-15**



**Replace the last paragraph of section 9-1.03 with:**

Pay your subcontractors within 7 days of receipt of each progress payment unless otherwise agreed to in writing (Bus & Prof Code § 7108.5). Violation of this section subjects you to the penalties, sanctions and other remedies of Bus and Prof § 7108.5. This section must not be construed to limit or impair any contractual, administrative, or judicial remedies otherwise available to you in the event of a dispute involving late payment or nonpayment by you, deficient subcontract performance, or noncompliance by a subcontractor.

**Replace section 9-1.07 with:**

“RESERVED”

**Replace the last sentence of the 3<sup>rd</sup> paragraph of section 9-1.16E(2) with:**

These amounts are shown on the *Pay Estimate*.

**Replace the last sentence of the 1<sup>st</sup> paragraph of section 9-1.16E(3) with:**

The documents include QC plans, schedules, traffic control plans, water pollution control submittals, and dust control submittals.

**Add to the 1<sup>st</sup> paragraph of section 9-1.16E(3):**

If you fail to comply with water pollution control or dust control requirements, the Department withholds part of the progress payment.

**Replace the 2<sup>nd</sup> paragraph of section 9-1.16E(4) with:**

Stop notice information may be obtained from the Engineer.

**Replace the section 9-1.16F with:**

**9-1.16F Retentions**

**9-1.16F(1) General**

The Department will retain 5% of the value of each progress payment (excluding mobilization payments) from each progress payment. After the Engineer determines that the project is substantially complete, the Department may, at the Engineer's sole discretion, release half of all retention previously withheld and reduce any subsequent retentions withheld from subsequent progress payments to 2.5% of the value of any subsequent progress payments (excluding mobilization payments). The retained funds will be retained until thirty five (35) days after recordation of the Notice of Acceptance. (Pub Cont Code §9203)

You may elect to receive one hundred percent (100%) of payments due under the Contract from time to time, without retention of any portion of the payment by the County, by depositing securities of equivalent value with the County (Pub Cont Code 22300). Securities eligible for deposit hereunder are limited to those listed in Section 16430 of the Government Code, or bank or savings and loan certificates of deposit.

Funds retained from progress payments to ensure performance of the Contract that are eligible for payment into escrow or to an escrow agent pursuant to Section 22300 of the Public Contract Code do not include funds withheld or deducted from payment due to your failure to fulfill a contract requirement.

**9-1.16F(2) Prompt Payment of Retained Funds to Subcontractors**

Section 9-1.16F(1) describes retainage and release of retainage to you. You and/or your subcontractor must return all monies withheld in retention from subcontractors within 30 days after receiving payment of retainage. Violation of this section subjects you to the penalties, sanctions, and other remedies of Bus & Prof Code § 7108.5. This section must not be construed to limit or impair any contractual, administrative, or judicial remedies otherwise available to you in the event of a dispute involving late payment or nonpayment by you, deficient subcontract performance, or noncompliance by a subcontractor.

**Replace section 9-1.22 “Arbitration” with:**

**9-1.22 DISPUTES RESOLUTION**

As permitted by Public Contract Code section 20104, the County has elected to resolve any claims between you and the County pursuant to Article 7.1 (commencing with Section 10240) of Chapter 1 of Part 2 of the Public Contract Code. Sections 5-1.43 and 9-1.17 describe the contract claim procedure. The provisions of these sections constitute a non-judicial claim settlement procedure, and also step one of a two-step claim presentment procedure by agreement under Section 930.2 of the California Government Code. Specifically, step one is compliance with the contract claim procedure in accordance with the Contract Documents, including but not limited to, sections 5-1.43 and 9-1.17. Step two is the filing of a timely Government Code Section 910 et seq. claim in accordance with the California Government Code. Any such claim shall affirmatively indicate your prior compliance with the contract claim procedure and previous dispositions under sections 5-1.43 and 9-1.17. Any claim that fails to conform to the contract claim procedure required in step one may not be asserted in any subsequent Government Code Section 910 et seq. claim.

As a condition precedent to arbitration or litigation, claims must first be mediated. Mediation is non-binding and the services of a mediator mutually acceptable to the parties must be used and, if the parties cannot agree, a mediator will be selected by the American Arbitration Association from its panel of approved mediators trained in construction industry mediation. All statutes of limitations shall be tolled from the date of the demand for mediation until a date two weeks following the mediation’s conclusion. The cost of mediation shall be equally shared by the parties.

If you fail to comply with these claim procedures as to any claim, then you waive your rights to this claim. County must not be deemed to waive or alter any provision of this section or sections 5-1.43 and 9-1.17 if, at County’s sole discretion, County administers a claim in a manner not in accord with those provisions.



**DIVISION II GENERAL CONSTRUCTION**

**10 GENERAL**

**Add to section 10-1.02 of the RSS for section 10-1:**

During construction maintain adequate drainage such that pre-construction drainage patterns are not compromised. The Engineer determines pre-construction drainage patterns.

**Add to section 10-1.02:**

Do not place the uppermost layer of new pavement until all underlying conduits and loop detectors are installed.

Before starting the traffic signal functional test at any location, all items of work related to signal control must be completed and all roadside signs, pavement delineation, and pavement markings must be in place at that location.

At the end of each working day if a difference in excess of 0.15 feet exists between the elevation of the existing pavement and the elevation of an excavation within 8 feet of the traveled way, place and compact material against the vertical cut adjacent to the traveled way. During the excavation operation, you may use native material for this purpose except once the placing of the structural section starts, structural material must be used. Place the material up to the top of the existing pavement and taper at a slope of 4:1 (horizontal:vertical) or flatter to the bottom of the excavation. Do not use treated base for the taper.

**Add to section 10-4 of the RSS dated 05-30-14:**

Contractor is advised there is currently a Stage 2 water warning in the El Dorado Irrigation District Service Area. Contractor is responsible for contacting the local water authorities to determine any impacts the water warnings will have on various items of work.

Payment for any water conservation plan is included in the payment for the various items of work.



**12 TEMPORARY TRAFFIC CONTROL**

**Add to section 12-1.01:**

You must submit a Traffic Control Plan for review and approval. Your Traffic Control Plan must address each type of temporary traffic control system that will be used. Your Traffic Control Plan must include detailed controls, including flaggers, lane closures, signs, and detours and signs, as applicable, for all items of road work which will require alteration of existing traffic patterns. Your Traffic Control Plan must include signing required on intersecting streets and driveways within the area that will require traffic control, and must address traffic controls related to truck traffic associated with the project's construction as well as access to driveways for all residences.

For traffic controls on Patterson Drive, you must not allow queued traffic to block access to the Towermart encroachment on Patterson Drive, or extend onto Pleasant Valley Road (State Route 49). Your Traffic Control Plan must include measures to ensure compliance with this requirement.

The allowed traffic controls on Patterson Drive include 1-lane 1-way traffic control for northbound vehicles between Crusader Road and Crown Point Drive, and between Griffith Road and Solstice Court, as well as reversing controls in the remaining locations within the project limits as shown in Exhibit A of Appendix C. Your Traffic Control Plan must include the southbound detour for the 1-way 1-lane controls.

For traffic controls associated with the work on Missouri Flat Road, you must maintain one (1) open lane for each direction of travel at all times.

Submit your Traffic Control Plan as early as ten (10) working days after the receipt of the Notice of Award but no later than five (5) working days of receipt of Notice to Proceed. No work will start on County roads until the Traffic Control Plan is approved. Violation of the Traffic Control requirements is justification for the Engineer to stop work until the requirements are met.

**Replace the 1<sup>st</sup> paragraph in section 12-1.03 with:**

Payment for all the work and materials associated with flagging, including flaggers is included in the bid item price for Traffic Control System.

**Replace Item 1.3 of the 1<sup>st</sup> paragraph of section 12-3.01A(3) with:**

Contract number, CIP number, Caltrans district, county, route and post mile of project limits or County Road name.

**Replace section 12-3.12A(2) with:**

**Section 12-3.12A(2) Definitions**

**Sign working day (SWD):** unit of measure for payment for Portable Changeable Message Sign – per sign per each day used.

**Replace section 12-3.12A(3) with:**

**12-3.12A(3) Submittals**

Upon notification, submit a certificate of compliance for each portable changeable message sign.

**Add section 12-3.12A(4):**

**12-3.12A(4) Quality Control and Assurance**

Comply with the manufacturer's operating instructions for the portable changeable message sign.

Approaching drivers must be able to read the entire message at least 2 times before passing the portable changeable message sign at the posted speed limit. Use more than 1 portable changeable message sign to comply with this requirement if necessary.

**Add to section 12-3.12C:**

Place and operate portable changeable message signs at the construction site one week prior to the start of the project. The Engineer will review and approve message and placement.

Place the portable changeable message sign in advance of the 1st warning sign for each Stationary lane closure

**Replace section 12-3.12D with:**

Portable changeable message sign is measured in sign working days (SWD). Portable changeable message signs at the project site but not in use will not be paid for.

**Add to section 12-4.01:**

When entering or leaving roadways carrying traffic, your equipment, whether empty or loaded must in all cases yield to traffic.

Project-related vehicles will observe the posted speed limit on hard-surfaced road and 15 miles per hour speed limit on unpaved roads during travel in the project area.

Local and emergency traffic must be allowed to pass through construction zones at all times with as little inconvenience as possible. At the end of the day's work or if construction is suspended, roadways must be opened for traffic in both directions.

Equipment actively engaged in construction must be confined to the safe work zone established by the installed temporary traffic control system, and will not be allowed to travel or encroach on the travel lane(s) used to convey local traffic through the project, unless traffic is controlled by an adequate number of flaggers.

If traffic cones or delineators are used to delineate a temporary edge of travel lane, the line of cones or delineators will be considered to be the edge of travel lane, however, you must not reduce the width of the travel lane to less than 10 feet within County right-of-way without written approval.

If rain or other causes, either within or beyond your control, forces delay of the work, you will in no way be relieved of your responsibility for maintaining traffic through the job site. You will at all times keep on the job site such material, force, and equipment as necessary to keep the roads within the project open to traffic and in good repair, and must expedite the passage of traffic using such labor and equipment as may be necessary.

Personal vehicles of your employees must not be parked on the traveled way or shoulders, including sections closed to traffic. You must make your own arrangements relative to keeping the work area clear of parked vehicles, whether belonging to your employees or to private individuals.

Payment for accommodating pedestrians and bicyclists through all traffic control work zones is included in the bid item price for Traffic Control System.

**Add to section 12-4.02A:**

You must provide access to driveways at all times. Notify the County in writing and property owners with door knob hangers at least 48 hours, but no more than 72 hours in advance of work that will affect an owner's driveway. You must submit a plan that describes how you will perform the contract work and provide access to driveways with no damage to any adjacent curb and gutter. Your Driveway Access Plan must include details of how the public entering the 1-way 1-lane traffic control from driveways within the closure limits will be notified of the closure, including the allowed direction of travel and the lane that is open to traffic. Your Driveway Access Plan must be submitted for approval at least one (1) week before work affecting driveways.

For grinding and grooving operations, saw cutting concrete slabs, and installing loop detectors, closure of the adjacent traffic lane is not required if an impact attenuator vehicle is used as a shadow vehicle.

Designated holidays are shown in the following table:

**Designated Holidays**

| Holiday               | Date Observed            |
|-----------------------|--------------------------|
| New Year's Day        | January 1st              |
| Washington's Birthday | 3rd Monday in February   |
| Memorial Day          | Last Monday in May       |
| Independence Day      | July 4th                 |
| Labor Day             | 1st Monday in September  |
| Veterans Day          | November 11th            |
| Thanksgiving Day      | 4th Thursday in November |
| Christmas Day         | December 25th            |

If a designated holiday falls on a Sunday, the following Monday is a designated holiday. If November 11th falls on a Saturday, the preceding Friday is a designated holiday.

For a one-way reversing traffic control lane closure, traffic may be stopped in 1 direction for periods not to exceed 10 minutes. After each stoppage, all accumulated traffic for that direction must pass through the work zone before another stoppage is made. If school buses are stopped with a queue, their direction of travel will be given priority.

For one-way reversing traffic control lane closure, flaggers must be placed at all intersecting streets and encroachments with multi-family residences.

One-way reversing traffic control operations will require the use of a pilot car per section 12-5.03 of these Special Provisions, with the exception of a one-way reversing traffic control on Patterson Drive between Crown Point Drive and Griffith Road.

The implementation of a one-way reversing traffic control is prohibited unless you are actively working within the limits of the reversing controls.

Personal vehicles of your employees must not be parked on the traveled way or shoulders, including sections closed to traffic.

If work vehicles or equipment are parked within 6 feet of a traffic lane, close the shoulder area with fluorescent orange traffic cones or portable delineators. Place the cones or delineators on a taper in advance of the parked vehicles or equipment and along the edge of the traveled way at 25-foot intervals to a point not less than 25 feet past the last vehicle or piece of equipment. Use at least 9 cones or delineators for the taper. Use a W20-1, "Road Work Ahead," W21-5b, "Right/Left Shoulder Closed Ahead," or C24(CA), "Shoulder Work Ahead," sign mounted on a crashworthy, portable sign support with flags. The sign must be 48 by 48 inches and placed as ordered by the Engineer. If a cone or delineator is displaced or overturned, immediately restore the device to its original position or location.

### **Replace the RSS dated 7-19-13 for section 12-4.03 with**

#### **12-4.03 CLSOURE SCHEDULE AND CONDITIONS**

##### **12-4.03A Closure Schedule**

Every Monday by noon, submit a closure schedule request of planned closures for the next week period. The next week period is defined as Sunday noon through the following Sunday noon.

Submit a closure schedule request not less than 7 days and not more than 25 days before the anticipated start of any activity that reduces:

1. Horizontal clearances of traveled ways, including shoulders, to 2 lanes or less due to activities such as temporary barrier placement and paving
2. Vertical clearances of traveled way, including shoulders, due to activities such as pavement overlays, overhead sign installation, falsework, or girder erection

Submit closure schedule amendments, including adding additional closures, by noon at least 3 business days before a planned closure.

Cancel closure requests at least 48 hours before the start time of the closure.

The Engineer may reschedule a closure cancelled due to unsuitable weather.

If a closure is not opened to traffic by the specified time, suspend work. No further closures are allowed until the Engineer has reviewed and authorized a work plan submitted by you that ensures that future closures will be opened to traffic by the specified time. Allow 2 business days for review of your proposed work plan. The Department does not compensate you for your losses due to the suspension of work resulting from the late opening of closures.

Notify the Engineer of delays in your activities caused by:

1. Your closure schedule request being denied although your requested closures are within the specified time frame allowed for closures. The Department does not compensate you for your losses due to amendments to the closure schedule that are not authorized.
2. Your authorized closure being denied.

If you are directed to remove a closure before the time designated in the authorized closure schedule, you will be compensated for the delay.

##### **12-4.03B Contingency Plan**

Section 12-4.03B applies if a contingency plan is specified in the special provisions or if a contingency plan is requested.

If a contingency plan is requested, submit the contingency plan within 1 business day of the request.

The contingency plan must identify the activities, equipment, processes, and materials that may cause a delay in the opening of a closure to traffic. The plan must include:

1. List of additional or alternate equipment, materials, or workers necessary to ensure continuing activities and on-time opening of closures if a problem occurs. If the additional or alternate equipment, materials, or workers are not on site, specify their location, the method for mobilizing these items, and the required time to complete mobilization.
2. General time-scaled logic diagram displaying the major activities and sequence of planned operations. For each activity, identify the critical event when the contingency plan will be activated.

Based on the Engineer's review, additional materials, equipment, workers, or time to complete activities from that specified in the contingency plan may be required.

Submit revisions to a contingency plan at least 3 business days before starting the activity requiring a contingency plan. Allow 2 business days for review of the revised contingency plan.

Replace "Reserved" in section 12-4.04 with:

| Lane Closure Restriction for Designated Holidays and Special Days |                                                                                 |                 |                 |                 |                 |                 |                 |     |     |     |
|-------------------------------------------------------------------|---------------------------------------------------------------------------------|-----------------|-----------------|-----------------|-----------------|-----------------|-----------------|-----|-----|-----|
| Thu                                                               | Fri                                                                             | Sat             | Sun             | Mon             | Tues            | Wed             | Thu             | Fri | Sat | Sun |
| x                                                                 | <b>H</b><br>xx                                                                  | xx              | xx              |                 |                 |                 |                 |     |     |     |
|                                                                   | <b>SD</b><br>xx                                                                 |                 |                 |                 |                 |                 |                 |     |     |     |
| x                                                                 | xx                                                                              | <b>H</b><br>xx  | xx              |                 |                 |                 |                 |     |     |     |
|                                                                   |                                                                                 | <b>SD</b><br>xx |                 |                 |                 |                 |                 |     |     |     |
|                                                                   | x                                                                               | xx              | <b>H</b><br>xx  | xx              |                 |                 |                 |     |     |     |
|                                                                   |                                                                                 |                 | <b>SD</b><br>xx |                 |                 |                 |                 |     |     |     |
|                                                                   | x                                                                               | xx              | xx              | <b>H</b><br>xx  | xxx             |                 |                 |     |     |     |
|                                                                   | x                                                                               | xx              | xx              | <b>SD</b><br>xx | xxx             |                 |                 |     |     |     |
|                                                                   |                                                                                 |                 |                 | x               | <b>H</b><br>xx  |                 |                 |     |     |     |
|                                                                   |                                                                                 |                 |                 | x               | <b>SD</b><br>xx |                 |                 |     |     |     |
|                                                                   |                                                                                 |                 |                 |                 | x               | <b>H</b><br>xx  |                 |     |     |     |
|                                                                   |                                                                                 |                 |                 |                 |                 | <b>SD</b><br>xx |                 |     |     |     |
|                                                                   |                                                                                 |                 |                 |                 |                 | x               | <b>H</b><br>xx  | xx  | xx  | xx  |
|                                                                   |                                                                                 |                 |                 |                 |                 |                 | <b>SD</b><br>xx |     |     |     |
| Legend:                                                           |                                                                                 |                 |                 |                 |                 |                 |                 |     |     |     |
|                                                                   | Refer to lane requirement charts                                                |                 |                 |                 |                 |                 |                 |     |     |     |
| x                                                                 | The full width of the traveled way must be open for use by traffic after 19:00. |                 |                 |                 |                 |                 |                 |     |     |     |
| xx                                                                | The full width of the traveled way must be open for use by traffic.             |                 |                 |                 |                 |                 |                 |     |     |     |
| xxx                                                               | The full width of the traveled way must be open for use by traffic until 7:00.  |                 |                 |                 |                 |                 |                 |     |     |     |
| <b>H</b>                                                          | Designated holiday                                                              |                 |                 |                 |                 |                 |                 |     |     |     |
| <b>SD</b>                                                         | Special day                                                                     |                 |                 |                 |                 |                 |                 |     |     |     |



Replace "Reserved" in section 12-4.05F with:

| Chart no. 1<br>Conventional Highway Lane Requirements                                             |    |   |   |   |   |   |                                  |   |   |   |    |    |    |    |    |    |     |    |    |    |    |    |    |    |    |
|---------------------------------------------------------------------------------------------------|----|---|---|---|---|---|----------------------------------|---|---|---|----|----|----|----|----|----|-----|----|----|----|----|----|----|----|----|
| County: El Dorado                                                                                 |    |   |   |   |   |   | Route/Direction: Patterson Drive |   |   |   |    |    |    |    |    |    | PM: |    |    |    |    |    |    |    |    |
| Closure limits: Lake Oaks Dr. to the end of County road at Solstice Ct.                           |    |   |   |   |   |   |                                  |   |   |   |    |    |    |    |    |    |     |    |    |    |    |    |    |    |    |
| Hour                                                                                              | 24 | 1 | 2 | 3 | 4 | 5 | 6                                | 7 | 8 | 9 | 10 | 11 | 12 | 13 | 14 | 15 | 16  | 17 | 18 | 19 | 20 | 21 | 22 | 23 | 24 |
| Mon-Thu                                                                                           | N  | N | N | N | N | N | N                                | T | T | T | T  | T  | T  | T  | T  | T  | T   | T  | T  | N  | N  | N  | N  | N  | N  |
| Fri                                                                                               | N  | N | N | N | N | N | N                                | T | T | T | T  | T  | T  | T  | T  | T  | T   | T  | T  | N  | N  | N  | N  | N  | N  |
| Sat                                                                                               | N  | N | N | N | N | N | N                                | N | N | N | N  | N  | N  | N  | N  | N  | N   | N  | N  | N  | N  | N  | N  | N  | N  |
| Sun                                                                                               | N  | N | N | N | N | N | N                                | N | N | N | N  | N  | N  | N  | N  | N  | N   | N  | N  | N  | N  | N  | N  | N  | N  |
| Legend:                                                                                           |    |   |   |   |   |   |                                  |   |   |   |    |    |    |    |    |    |     |    |    |    |    |    |    |    |    |
| <input type="checkbox"/> T Traffic controls allowed<br><input type="checkbox"/> N No work allowed |    |   |   |   |   |   |                                  |   |   |   |    |    |    |    |    |    |     |    |    |    |    |    |    |    |    |
| REMARKS: Refer to the approved Traffic Control Plan for the necessary lane requirements           |    |   |   |   |   |   |                                  |   |   |   |    |    |    |    |    |    |     |    |    |    |    |    |    |    |    |

| Chart no. 2<br>Conventional Highway Lane Requirements                                                                                               |    |   |   |   |   |   |                                   |   |   |   |    |    |    |    |    |    |     |    |    |    |    |    |    |    |    |
|-----------------------------------------------------------------------------------------------------------------------------------------------------|----|---|---|---|---|---|-----------------------------------|---|---|---|----|----|----|----|----|----|-----|----|----|----|----|----|----|----|----|
| County: El Dorado                                                                                                                                   |    |   |   |   |   |   | Route/Direction: Missouri Flat Rd |   |   |   |    |    |    |    |    |    | PM: |    |    |    |    |    |    |    |    |
| Closure limits: State Route 49 and approx. 1000 feet north.                                                                                         |    |   |   |   |   |   |                                   |   |   |   |    |    |    |    |    |    |     |    |    |    |    |    |    |    |    |
| Hour                                                                                                                                                | 24 | 1 | 2 | 3 | 4 | 5 | 6                                 | 7 | 8 | 9 | 10 | 11 | 12 | 13 | 14 | 15 | 16  | 17 | 18 | 19 | 20 | 21 | 22 | 23 | 24 |
| Mon-Thu                                                                                                                                             | 2  | 2 | 2 | 2 | 2 | 2 | N                                 | N | N | N | N  | N  | N  | N  | N  | N  | N   | N  | N  | N  | 2  | 2  | 2  | 2  | 2  |
| Fri                                                                                                                                                 | 2  | 2 | 2 | 2 | 2 | 2 | N                                 | N | N | N | N  | N  | N  | N  | N  | N  | N   | N  | N  | N  | 2  | 2  | 2  | 2  | 2  |
| Sat                                                                                                                                                 | 2  | 2 | 2 | 2 | 2 | 2 | N                                 | N | N | N | N  | N  | N  | N  | N  | N  | N   | N  | N  | N  | N  | N  | N  | N  | N  |
| Sun                                                                                                                                                 | N  | N | N | N | N | N | N                                 | N | N | N | N  | N  | N  | N  | N  | N  | N   | N  | N  | N  | 2  | 2  | 2  | 2  | 2  |
| Legend:                                                                                                                                             |    |   |   |   |   |   |                                   |   |   |   |    |    |    |    |    |    |     |    |    |    |    |    |    |    |    |
| <input type="checkbox"/> 2 Provide at least 2 through traffic lanes. One for each direction of travel<br><input type="checkbox"/> N No work allowed |    |   |   |   |   |   |                                   |   |   |   |    |    |    |    |    |    |     |    |    |    |    |    |    |    |    |
| REMARKS:                                                                                                                                            |    |   |   |   |   |   |                                   |   |   |   |    |    |    |    |    |    |     |    |    |    |    |    |    |    |    |

**Chart no. 3  
Conventional Highway Lane Requirements**

|                                                                                                                                                                                      |                                                                            |   |   |   |   |   |                             |   |   |   |    |    |    |          |    |    |    |    |    |    |    |    |    |    |    |  |  |   |                                                                            |   |                 |
|--------------------------------------------------------------------------------------------------------------------------------------------------------------------------------------|----------------------------------------------------------------------------|---|---|---|---|---|-----------------------------|---|---|---|----|----|----|----------|----|----|----|----|----|----|----|----|----|----|----|--|--|---|----------------------------------------------------------------------------|---|-----------------|
| County: El Dorado                                                                                                                                                                    |                                                                            |   |   |   |   |   | Route/Direction: Highway 49 |   |   |   |    |    |    | PM: 11.0 |    |    |    |    |    |    |    |    |    |    |    |  |  |   |                                                                            |   |                 |
| Closure limits: 500 feet east and 500 feet west of the Missouri Flat Road intersection                                                                                               |                                                                            |   |   |   |   |   |                             |   |   |   |    |    |    |          |    |    |    |    |    |    |    |    |    |    |    |  |  |   |                                                                            |   |                 |
| Hour                                                                                                                                                                                 | 24                                                                         | 1 | 2 | 3 | 4 | 5 | 6                           | 7 | 8 | 9 | 10 | 11 | 12 | 13       | 14 | 15 | 16 | 17 | 18 | 19 | 20 | 21 | 22 | 23 | 24 |  |  |   |                                                                            |   |                 |
| Mon-Thu                                                                                                                                                                              | 2                                                                          | 2 | 2 | 2 | 2 | 2 | N                           | N | N | N | N  | N  | N  | N        | N  | N  | N  | N  | N  | N  | 2  | 2  | 2  | 2  |    |  |  |   |                                                                            |   |                 |
| Fri                                                                                                                                                                                  | 2                                                                          | 2 | 2 | 2 | 2 | 2 | N                           | N | N | N | N  | N  | N  | N        | N  | N  | N  | N  | N  | N  | 2  | 2  | 2  | 2  |    |  |  |   |                                                                            |   |                 |
| Sat                                                                                                                                                                                  | 2                                                                          | 2 | 2 | 2 | 2 | 2 | N                           | N | N | N | N  | N  | N  | N        | N  | N  | N  | N  | N  | N  | N  | N  | N  | N  |    |  |  |   |                                                                            |   |                 |
| Sun                                                                                                                                                                                  | N                                                                          | N | N | N | N | N | N                           | N | N | N | N  | N  | N  | N        | N  | N  | N  | N  | N  | N  | 2  | 2  | 2  | 2  |    |  |  |   |                                                                            |   |                 |
| Legend:                                                                                                                                                                              |                                                                            |   |   |   |   |   |                             |   |   |   |    |    |    |          |    |    |    |    |    |    |    |    |    |    |    |  |  |   |                                                                            |   |                 |
| <table border="1"> <tr> <td>2</td> <td>Provide at least 2 through traffic lanes. One for each direction of travel</td> </tr> <tr> <td>N</td> <td>No work allowed</td> </tr> </table> |                                                                            |   |   |   |   |   |                             |   |   |   |    |    |    |          |    |    |    |    |    |    |    |    |    |    |    |  |  | 2 | Provide at least 2 through traffic lanes. One for each direction of travel | N | No work allowed |
| 2                                                                                                                                                                                    | Provide at least 2 through traffic lanes. One for each direction of travel |   |   |   |   |   |                             |   |   |   |    |    |    |          |    |    |    |    |    |    |    |    |    |    |    |  |  |   |                                                                            |   |                 |
| N                                                                                                                                                                                    | No work allowed                                                            |   |   |   |   |   |                             |   |   |   |    |    |    |          |    |    |    |    |    |    |    |    |    |    |    |  |  |   |                                                                            |   |                 |
| REMARKS:                                                                                                                                                                             |                                                                            |   |   |   |   |   |                             |   |   |   |    |    |    |          |    |    |    |    |    |    |    |    |    |    |    |  |  |   |                                                                            |   |                 |

**Replace section 12-5 with:**

**12-5 TRAFFIC CONTROL SYSTEM FOR LANE CLOSURE**

**12-5.01 GENERAL**

Section 12-5 includes specifications for closing traffic lanes with stationary lane closures on 2-lane, 2-way highways. The traffic control system for a lane closure must comply with the details shown.

Traffic control system includes signs.

**12-5.02 MATERIALS**

Not Used

**12-5.03 CONSTRUCTION**

Whenever components of the traffic control system are displaced or cease to operate or function as specified from any cause, immediately repair the components to the original condition or replace the components and restore the components to the original location.

For a stationary lane closure made only for the work period, remove the components of the traffic control system from the traveled way and shoulder, except for portable delineators placed along open trenches or excavation adjacent to the traveled way at the end of each work period. You may store the components at selected central locations designated by the Engineer within the limits of the highway.

Use a pilot car to control traffic when a one-way reversing control is implemented, with the exception of a one-way reversing traffic control between Crown Point Drive and Griffith Road when combined with a one-lane one-way control on Patterson Drive. The cones shown along the centerline need not be placed. The pilot car must have radio contact with personnel in the work area. Operate the pilot car through the traffic control zone at a speed not greater than 25 miles per hour.

#### **12-5.04 PAYMENT**

Traffic control system for lane closure is paid for as traffic control system. Flagging costs are paid for as specified in section 12-1.03.

A traffic control system required by change order work is paid for as a part of the change order work.

#### **Replace section 12-8 with:**

#### **12-8 TEMPORARY PAVEMENT DELINEATION**

##### **12-8.01 GENERAL**

Section 12-8 includes specifications for placing, applying, maintaining, and removing temporary pavement delineation.

Temporary Painted traffic stripes and painted pavement markings used for temporary delineation must comply with section 84-3.

Temporary signing for no-passing zones must comply with section 12-3.06.

##### **12-8.02 MATERIALS**

###### **12-8.02A General**

Not Used

###### **12-8.02B Temporary Lane Line and Centerline Delineation**

Temporary pavement markers must be the same color as the lane line or centerline markers being replaced. Temporary pavement markers must be one of the temporary pavement markers on the Authorized Material List for short-term day or night use, 14 days or less, or long-term day or night use, 180 days or less.

##### **12-8.03 CONSTRUCTION**

###### **12-8.03A General**

Whenever work activities obliterate pavement delineation, place temporary or permanent pavement delineation before opening the traveled way to traffic. Place lane line and centerline pavement delineation for traveled ways open to traffic.

Establish the alignment for temporary pavement delineation, including required lines or markers. Surfaces to receive an application of paint or removable traffic tape must be dry and free of dirt and loose material. Do not apply temporary pavement delineation over existing pavement delineation or other temporary pavement delineation. Maintain temporary pavement delineation until it is superseded or you replace it with a new striping detail of temporary pavement delineation or permanent pavement delineation.

Place temporary pavement delineation on or adjacent to lanes open to traffic for a maximum of 14 days. Before the end of the 14 days, place the permanent pavement delineation. If the permanent pavement delineation is not placed within the 14 days, replace the temporary pavement markers with additional temporary pavement delineation equivalent to the striping detail specified for the permanent pavement delineation for the area. The Department does not pay for the additional temporary pavement delineation.

When the Engineer determines the temporary pavement delineation is no longer required for the direction of traffic, remove the markers, and underlying adhesive, and removable traffic tape from the final layer of surfacing and from the existing pavement to remain in place. Remove temporary pavement delineation that conflicts with any subsequent or new traffic pattern for the area.

###### **12-8.03B Temporary Lane Line and Centerline Delineation**

Whenever lane lines or centerlines are obliterated, the minimum lane line and centerline delineation must consist of temporary pavement markers placed longitudinally at intervals not exceeding 24 feet. The temporary pavement markers must be temporary pavement markers on the Authorized Material List for

short-term day or night use, 14 days or less, or long-term day or night use, 180 days or less. Place temporary pavement markers under the manufacturer's instructions. Cement the markers to the surfacing with the adhesive recommended by the manufacturer, except do not use epoxy adhesive to place pavement markers in areas where removal of the markers will be required.

For temporary lane line or centerline delineation consisting entirely of temporary pavement markers, place the markers longitudinally at intervals not exceeding 24 feet.

**12-8.04 PAYMENT**

Not Used



**13 WATER POLLUTION CONTROL**

**Delete the paragraph added to section 13-1.01A of the RSS dated 11-15-13.**

**Add item 4. to the list in the 1<sup>st</sup> paragraph of section 13-1.03C**

- 4. Inspect sanitary and septic waste storage and monitor disposal procedures weekly.

**Replace the 2<sup>nd</sup> paragraph of section 13-2.01A with:**

Prepare water pollution control program includes developing, amending, and implementing the WPCP, providing a WPC Manager, conducting WPC training, and installing, monitoring, inspecting, reporting on, maintaining, and removing and disposing of WPC practices at the job site.

**Replace the 3<sup>rd</sup> paragraph of section 13-2.01B in the RSS dated 4-19-13 with:**

The Engineer will not postpone issuance of the Notice to Proceed if your WPCP submittal fails to meet the contract requirements requiring multiple submittals and reviews of your WPCP.

**Replace the 1<sup>st</sup> paragraph of section 13-2.01B in the RSS dated 4-19-13 with:**

- 1. Within 7 days after the date of the Notice of Award letter submit 3 copies of the WPCP and allow 7 days for the Engineer's review. If revisions are required, the Engineer provides comments and specifies the date that the review stopped.
- 2. Change and resubmit the WPCP within 7 days of receipt of the Engineer's comments. The Engineer's review resumes when the complete WPCP is resubmitted.
- 3. When the Engineer accepts the WPCP, submit an electronic copy and 4 printed copies of the accepted WPCP.

The Engineer will not postpone issuance of the Notice to Proceed if your WPCP submittal fails to meet the contract requirements requiring multiple submittals and reviews of your WPCP.

**Add to section 13-2.03:**

If the Engineer determines that resources sufficient to bring you into compliance with section 13 have not been allocated, the Engineer may redirect any of your resources available at the project site toward this effort. If the Engineer redirects resources due to your non-compliance with the provisions of section 13, the County will not be responsible for any delays to your schedule resulting from the reallocation, and no compensation will be made for these delays.

**Replace item 2 in section 13-2.04 with:**

The Department pays for prepare water pollution control program under “Job Site Management”.  
The Department pays for implementation of WPC practices under “Job Site Management”.

**Add to the 3<sup>rd</sup> paragraph of Section 13-4.03F:**

3. 8 hours of predicted rain

**Delete the 1<sup>st</sup> sentence of section 13-5.04.**

**Replace the 2<sup>nd</sup> paragraph of section 13-5.04 with:**

The Department pays for temporary soil stabilization under job site management

**Replace section 13-6.04 with:**

The Department pays for temporary sediment control under job site management.

**Replace section 13-7.04 with:**

The Department pays for temporary tracking control under job site management.

**Replace section 13-9.04 with:**

The Department pays for temporary concrete washouts under job site management.



**14 ENVIRONMENTAL STEWARDSHIP**

**Replace section 14-8.02A with:**

The work on Patterson Drive is located in a Community Region with Higher Density Residential and Commercial land use designations for Patterson Drive and Missouri Flat Road, respectively.

The following table specifies the maximum allowable noise exposure for work within the community types and land use designations listed above.

| <b>MAXIMUM ALLOWABLE NOISE EXPOSURE FOR NONTRANSPORTATION NOISE SOURCES IN COMMUNITY REGIONS AND ADOPTED PLAN AREAS—CONSTRUCTION NOISE</b>                                                   |                    |                         |                        |
|----------------------------------------------------------------------------------------------------------------------------------------------------------------------------------------------|--------------------|-------------------------|------------------------|
| <b>Land Use Designation<sup>1</sup></b>                                                                                                                                                      | <b>Time Period</b> | <b>Noise Level (dB)</b> |                        |
|                                                                                                                                                                                              |                    | <b>L<sub>eq</sub></b>   | <b>L<sub>max</sub></b> |
| Higher-Density Residential (MFR, HDR, MDR)                                                                                                                                                   | 7 am–7 pm          | 55                      | 75                     |
|                                                                                                                                                                                              | 7 pm–10 pm         | 50                      | 65                     |
|                                                                                                                                                                                              | 10 pm–7 am         | 45                      | 60                     |
| Commercial and Public Facilities (C, R&D, PF)                                                                                                                                                | 7 am–7 pm          | 70                      | 90                     |
|                                                                                                                                                                                              | 7 pm–7 am          | 65                      | 75                     |
| Industrial (I)                                                                                                                                                                               | Any Time           | 80                      | 90                     |
| <p>Note:</p> <p>1 Adopted Plan areas should refer to those land use designations that most closely correspond to the similar General Plan land use designations for similar development.</p> |                    |                         |                        |

The noise level requirements apply to the equipment on the job or related to the job measured at the affected building facade, including trucks, transit mixers or transient equipment that you may or may not own. Avoid the use of loud sound signals in favor of light warnings except those required by safety laws for the protection of personnel.

In the interest of the public safety and/or public convenience, the allowable noise levels may be waived.

Implement appropriate additional noise mitigation measures, including changing the location of stationary construction equipment, shutting off idling equipment, rescheduling your activity, notifying adjacent residents in advance of construction work, and installing acoustic barriers around stationary construction noise sources such that noise from construction does not exceed the limits specified above. If the existing background noise levels exceed the values above, then the limit for construction noise may be increased from the background noise level by the same percentage that the background noise level exceeds the values above.

**Add to section 14-9.02A:**

Comply with applicable State and County Air Quality Management District (AQMD) rules and regulations regarding reduction of construction related impacts on air quality, including the implementation of the following measures:

- Use low-emission onsite mobile construction equipment.
- Maintain equipment in tune per manufacturer's specifications.
- Retard diesel engine injection timing by two to four degrees unless not recommended by manufacturer (due to lower emission output in-place).
- Use reformulated low-emission diesel fuel.
- Substitute electric and gasoline-powered equipment for diesel-powered equipment where feasible.
- Use catalytic converters on gasoline-powered equipment.
- Do not leave inactive construction equipment idling for prolonged periods (i.e., more than 2 minutes).
- Support and encourage ridesharing and transit for the construction workers.
- All construction vehicles and equipment shall be fitted with working mufflers.

**Replace section 14-9.03 with:**

**14-9.03 DUST CONTROL**

**14-9.03A General**

**14-9.03A(1) Summary**

Section 14-9.03 includes specifications relating to dust control.

Comply with Rules 223, 223-1 and 223-2 (Dust Rules) of the Rules and Regulations of the El Dorado County Air Quality Management District (AQMD).

The Dust Rules can be obtained from the AQMD, 330 Fair Lane, Placerville, CA, 95667, (530) 621-6662, and are available at AQMD's website.

The materials within the project limits are neither known nor suspected to contain naturally occurring asbestos and the project is not located within designated Naturally Occurring Asbestos Review Areas on the current El Dorado County Naturally Occurring Asbestos Review Area Map.

**14-9.03A(2) Submittals**

Submit a site specific Fugitive Dust Control Plan / Fugitive Dust Plan (FDP) for all proposed work, meeting the requirements of Dust Rules approved by AQMD, to the AQMD prior to start of any work. Provide the Engineer with four (4) copies of the AQMD approved FDP prior to starting any work that may generate dust.

Prepare an amendment to the FDP when there is a change in construction activities not included in the FDP, when the Contractor's activities violate a condition of AQMD, or when ordered by the Engineer. Amendments must identify additional dust control practices or revised operations, including those areas or activities not identified in the initially approved FDP. Amendments to the FDP must be prepared and submitted for review and approval within a time approved by the Engineer. At a minimum, the FDP must be amended annually.

Keep one (1) copy of the approved FDP and approved amendments at the project site. Make the FDP available upon request by a representative of the AQMD, California Air Resource Board, United States Environmental Protection Agency, or Caltrans. Requests by the public must be directed to the Engineer.

Provide all notices to the AQMD and create and maintain all records as required by Dust Rules. Copies of all related records must be submitted to the Engineer within thirty (30) calendar days of completion of the work.

**14-9.03B Materials**

Not used.

**14-9.03C Construction**

Implement the measures contained in the FDP to control dust.

Control dust using measures that include the following:

1. Stabilize unpaved areas subject to vehicular traffic by keeping adequately wetted, or covered with material that contains less than 0.25 percent asbestos.
2. The speed of vehicles and equipment traveling across unpaved areas must not be more than 15 mph unless the road surface and surrounding area is sufficiently stabilized to prevent vehicles and equipment going faster from causing dust that is visible from crossing job site limits.
3. Stockpiles and disturbed areas not subject to vehicular traffic must be located in the plan and stabilized by being kept adequately wetted, or covered with material that contains less than 0.25 percent asbestos.

4. Conduct activities so that no dirt or mud tracking is visible on any paved roadway open to the public.
5. Use rock track out pads and wheel wash stations at all points of egress from unpaved construction areas.
6. Use a dedicated water truck for each piece of earthmoving equipment (e.g., scrapers, dozers, excavators, loaders, haul trucks, backhoes, compactors, graders, etc),
7. Pre-wet excavations to depths of cuts.

Dust control measures that will be required to mitigate dust may impact your productivity during construction activities.

**Replace section 14-9.03D with:**

**14-9.03D Payment**

The Department does not pay for impacts to your productivity from mitigating dust from your activities.

If naturally occurring asbestos is found within the project limits, prepare an Asbestos Dust Mitigation Plan. Preparing an Asbestos Dust Mitigation Plan and its implementation is change order work.

Payment for preparing, obtaining approval for, revising, and amending the FDP, for AQMD FDP review fees, and for maintaining and submitting all dust control records is paid for under Prepare Fugitive Dust Plan. Payment for performing dust control is paid for under the various items of work.

**Replace section 14-10.02 with:**

**14-10.02 SOLID WASTE DISPOSAL AND RECYCLING**

Prior to commencement of construction prepare and obtain County approval of Solid Waste Diversion and Recycling Plan that complies with County Ordinance Chapter 8.43- "Construction and Demolition Debris Recycling Within El Dorado County" that demonstrates the diversion and recycling of salvageable and re-useable wood, metal, plastic, and paper products during construction.

**Replace section 14-11.07 with:**

**14-11.07 REMOVE YELLOW TRAFFIC STRIPE AND PAVEMENT MARKING WITH HAZARDOUS WASTE RESIDUE**

**14-11.07A General**

**14-11.07A(1) Summary**

Section 14-11.07 includes specifications for removing existing yellow thermoplastic stripe and pavement marking. The residue from the removal of this material is a Department-generated hazardous waste.

Section 14-11.07 pertains only to the yellow thermoplastic traffic stripe on Missouri Flat Road.

Residue from removal of yellow thermoplastic traffic stripe pavement marking contains lead chromate. The average lead concentration is at least 1,000 mg/kg total lead or 5 mg/l soluble lead. When applied to the roadway, the yellow thermoplastic stripe and pavement marking contained as much as 2.6 percent lead. Residue produced from the removal of this yellow thermoplastic traffic stripe and pavement marking contains heavy metals in concentrations that exceed thresholds established by the Health & Safety Code and 22 CA Code of Regs. For bidding purposes, assume the residue is not regulated under the Federal Resource Conservation and Recovery Act (RCRA), 42 USC § 6901 et seq.

Work associated with disposal of hazardous waste residue regulated under RCRA as determined by test results is change order work.



Yellow thermoplastic may produce toxic fumes when heated.

**14-11.07A(2) Submittals**

**14-11.07A(2)(a) General**

Reserved

**14-11.07A(2)(b) Lead Compliance Plan**

Submit a lead compliance plan under section 7-1.02K(6)(j)(ii).

**14-11.07A(2)(c) Work Plan**

Submit a work plan for the removal, containment, storage, and disposal of yellow thermoplastic traffic stripe and pavement marking. The work plan must include:

1. Objective of the operation
2. Removal equipment
3. Procedures for removal and collection of yellow thermoplastic and traffic stripe and pavement marking residue, including dust
4. Type of hazardous waste storage containers
5. Container storage location and how it will be secured
6. Hazardous waste sampling protocol and QA/QC requirements and procedures
7. Qualifications of sampling personnel
8. Analytical lab that will perform the analyses
9. DTSC registration certificate and CA Highway Patrol (CHP) Biennial Inspection of Terminals (BIT) Program compliance documentation of the hazardous waste hauler that will transport the hazardous waste
10. Disposal site that will accept the hazardous waste residue

The Engineer will review the work plan within 5 business days of receipt.

Do not perform work that generates hazardous waste residue until the work plan has been authorized.

Correct any rejected work plan and resubmit a corrected work plan within 5 business days of notification by the Engineer. A new review period of 5 business days will begin from date of resubmittal.

**14-11.07A(2)(d) Analytical Test Results**

Submit analytical test results of the residue from removal of yellow thermoplastic traffic stripe and pavement markings, including chain of custody documentation, for review and acceptance before:

1. Requesting the Engineer's signature on the waste profile requested by the disposal facility
2. Requesting the Engineer obtain a US EPA Generator Identification Number for disposal
3. Removing the residue from the site

**14-11.07A(2)(e) U.S. Environmental Protection Agency (EPA) Identification Number Request**

Submit a request for the US EPA Generator Identification Number when the Engineer accepts analytical test results documenting that residue from removal of yellow thermoplastic traffic stripe and pavement marking is a hazardous waste.

**14-11.07A(2)(f) Disposal Documentation**

Submit documentation of proper disposal from the receiving landfill within 5 business days of residue transport from the project.

**14-11.07B Materials**

Not Used

**14-11.07C Construction**

Where grinding or other authorized methods are used to remove yellow thermoplastic and yellow painted traffic stripe and pavement marking that will produce a hazardous waste residue, immediately contain and collect the removed residue, including dust. Use a high efficiency particulate arrestance (HEPA) filter-equipped vacuum attachment operated concurrently with the removal operations or other equally effective approved methods for collection of the residue.

Make necessary arrangements to test the yellow thermoplastic hazardous waste residue as required by the disposal facility and these special provisions. Testing must include:

1. Total lead by US EPA Method 6010B
2. Total chromium by US EPA Method 6010B
3. Soluble lead by California Waste Extraction Test (CA WET)
4. Soluble chromium by CA WET
5. Soluble lead by Toxicity Characteristic Leaching Procedure (TCLP)
6. Soluble chromium by TCLP

From the first 220 gal of hazardous waste or portion thereof if less than 220 gal of hazardous waste are produced, a minimum of 4 randomly selected samples must be taken and analyzed individually. Samples must not be composited. From each additional 880 gal of hazardous waste or portion thereof if less than 880 gal are produced, a minimum of 1 additional random sample must be taken and analyzed. Use chain of custody procedures consistent with chapter 9 of US EPA Test Methods for Evaluating Solid Waste, Physical/Chemical Methods (SW-846) while transporting samples from the project to the laboratory. Each sample must be homogenized before analysis by the laboratory performing the analyses. A sample aliquot sufficient to cover the amount necessary for the total and the soluble analyses must then be taken. This aliquot must be homogenized a 2nd time and the total and soluble analyses run on this aliquot. The homogenization process must not include grinding of the samples. Submit the name and location of the disposal facility that will be accepting the hazardous waste and the analytical laboratory along with the testing requirements not less than 5 business days before the start of removal of yellow thermoplastic traffic stripe and pavement marking. The analytical laboratory must be certified by the State Water Resources Control Board (SWRCB) Environmental Laboratory Accreditation Program (ELAP) for all analyses to be performed.

After the Engineer accepts the analytical test results, dispose of yellow thermoplastic hazardous waste residue at a Class 1 disposal facility located in California under the requirements of the disposal facility operator within 30 days after accumulating 220 pounds of residue and dust.

If less than 220 pounds of hazardous waste residue and dust is generated in total, dispose of it within 30 days after the start of accumulation of the residue and dust.

The Engineer will sign all manifests as the generator within 2 business days of receiving and accepting the analytical test results and receiving your request for the US EPA Generator Identification Number. Use a transporter with a current DTSC registration certificate and that is in compliance with the CHP BIT Program when transporting hazardous waste.

**14-11.07D Payment**

The Department pays for the work plan under lead compliance plan.

If analytical test results demonstrate that the residue is a non-hazardous waste and the Engineer agrees, dispose of the residue at an appropriately permitted CA Class II or CA Class III facility. The Department does not adjust payment for this disposal.



## 15 EXISTING FACILITIES

Replace section 15-2.02B(3) with:

### 15-2.02B(3) Cold Planing Asphalt Concrete Pavement

#### 15-2.02B(3)(a) General

Cold planing AC consists of roadway conforms, gutter conforms, profile grinding, and cold planing the Griffith intersection on Patterson Drive, and cold planing on Missouri Flat Road. The approximate locations and details are shown in Exhibit B-1 through B-7 of Appendix C of these Special Provisions.

For Missouri Flat Road, schedule cold planing activities to begin on a Monday, and ensure that cold planing, signal modification work, and placement of HMA is completed within 72 hours.

For Missouri Flat Road, remove the yellow thermoplastic traffic stipe prior to cold planing.

For Patterson Drive, schedule cold planing activities such that no more than 48 hours elapses between the time the pavement is cold planed and the HMA is placed.

For Patterson Drive within the Griffith intersection limits as shown in Exhibits B-1 and B-5 of Appendix C, maintain a smooth driving surface on the underlying material at all times.

#### 15-2.02B(3)(b) Materials

Use the same quality of HMA for temporary tapers that is used for the HMA overlay or comply with the specifications for minor HMA in section 39.

#### 15-2.02B(3)(c) Construction

##### 15-2.02B(3)(c)(i) General

Before any cold planing work is performed, the Engineer will mark the limits of each area.

Mark the limits and locations of all existing traffic stripes and pavement markings that will be cold planed prior to any cold planing activities.

For each roadway conform, cold plane AC to a depth of 0.20 feet at the roadway conform limit and taper to match the gutter conform and profile grind at the match line as shown in Exhibit B-2 of Appendix C. The roadway conform must be smooth and uniform in its transition from the roadway conform limit to the match line.

For each gutter conform, cold plane AC to a depth of 0.15 feet at the face of gutter and taper to a zero depth across a length of 8.0 feet as shown in Exhibits B-3 and B-4 of Appendix C.

For intersecting streets without a valley gutter, cold plane AC to a depth of 0.20 feet at the conform limit and taper to match the gutter conform at the match line as shown in Exhibits B-3 and B-4 of Appendix C.

For intersecting streets with a valley gutter, cold plane AC to a depth 0.20 feet at the face of the valley gutter and taper to match the gutter conform at the match line as shown in Exhibits B-3 and B-4 of Appendix C.

For the Griffith intersection on Patterson Drive, cold plane AC such that 0.35 feet of HMA can be placed with a uniform cross slope across Patterson Drive and between the grind limits within the limits shown in Exhibit B-5 of Appendix C.

For the profile grind, cold plane the minimum depth of AC required to meet the surface smoothness requirements as specified in section 15-2.02B(3)(c)(ii).

On Missouri Flat Road, cold plane AC to a depth of 0.20 feet within the limits shown in Exhibit B-7.

Do not use a heating device to soften the pavement.

The cold planing machine must be:

1. Equipped with a cutter head width that matches the planing width. If the cutter head width is wider than the cold plane area shown, submit to the Engineer a request for using a wider cutter head. Do not cold plane unless the Engineer approves your request.
2. **Equipped with a micro mill ¼ inch strike pattern cutter head.**
3. Equipped with automatic controls for the longitudinal grade and transverse slope of the cutter head and:
  - 3.1. If a ski device is used, it must be at least 30 feet long, rigid, and a 1-piece unit. The entire length must be used in activating the sensor.
  - 3.2. If referencing from existing pavement, the cold planing machine must be controlled by a self-contained grade reference system. The system must be used at or near the centerline of the roadway. On the adjacent pass with the cold planing machine, a joint-matching shoe may be used.
4. Equipped to effectively control dust generated by the planing operation
5. Operated so that no fumes or smoke is produced.

Replace broken, missing, or worn machine teeth.

In order to mitigate against potential AC pavement failures between cold planing and placement of HMA, you must have a backhoe and a roller available and on site from the time cold planing activities begin until the placement of the HMA overlay is completed. If a pavement failure is identified by the Engineer remove the underlying material and replace with HMA as directed by the Engineer. Use the same quality of HMA that is used for the HMA overlay as specified in section 39. The placement of HMA must meet the surface smoothness requirements as specified in section 15-2.02B(3)(c)(ii). This work is change order work and will be paid for in accordance with section 9-1.04.

#### **15-2.02B(3)(c)(ii) Grade Control and Surface Smoothness**

Furnish, install, and maintain grade and transverse slope references and smoothness requirements.

The depth, length, width, and shape of the cut must be as shown or as ordered. The final cut must result in a neat and uniform surface. Do not damage the remaining surface.

The completed surface of the planed asphalt concrete pavement must not vary more than 0.02 foot when measured with a 12-foot straightedge parallel with the centerline. With the straightedge at right angles to the centerline, the transverse slope of the planed surface must not vary more than 0.03 foot.

For Patterson Drive, the transverse slope for the profile grind and the gutter conform will be evaluated independently with respect to the transverse surface smoothness requirements.

For the profile grind, if there are areas within the project limits that you do not think will be able to meet the straightedge requirements, notify the Engineer prior to performing any cold planing activities. The Engineer will review the area, and if the Engineer is in agreement, the area will be marked and the straightedge requirements will be waived for the marked section.

Where lanes are open to traffic, the drop-off of between adjacent lanes must not be more than 0.15 foot.

#### **15-2.02B(3)(c)(iii) Temporary HMA Tapers**

If a drop-off between the existing pavement and the planed area at transverse joints cannot be avoided before opening to traffic, construct a temporary HMA taper. The HMA temporary taper must be:

1. Placed to the level of the existing pavement and tapered on a slope of 60:1 (horizontal:vertical) or flatter to the level of the planed area
2. Compacted by any method that will produce a smooth riding surface

Completely remove temporary tapers before placing permanent surfacing.

**15-2.02B(3)(c)(iv) Remove Planed Material**

Remove cold planed material concurrent with planing activities so that removal does not lag more than 50 feet behind the planer.

**15-2.02B(3)(d) Payment**

Payment for removal of pavement markers, thermoplastic traffic stripe, painted traffic stripe, pavement marking, and loop detectors within the area of cold planing is included in the payment for cold plane asphalt concrete pavement of the types shown in the Bid Item List.

Payment for maintaining grade and transverse slope references and smoothness requirements for each cold planed surface is included in the payment for cold plane asphalt concrete pavement of the types shown in the Bid Item List.

Payment for cold plane asphalt concrete within the roadway conform limits, Griffith Intersection limits, and Missouri Flat Road limits is paid for under Cold Plane Asphalt Concrete (Conform Grind).

Payment for cold plane asphalt concrete within the gutter conform limits, including the extensions at intersections, is paid for under Cold Plane Asphalt Concrete (Conform Grind).

Payment for cold plane asphalt concrete within the profile grind limits is paid for under Cold Plane Asphalt Concrete (Profile Grind). You are directed to assume a uniform 0.10 foot cold plane depth for the purposes of bidding the Cold Plane Asphalt Concrete (Profile Grind) item.

The Department does not pay for any cold planing outside the limits marked in the field by the Engineer.

**Replace the last 2 sentences of the 1<sup>st</sup> paragraph of section 15-2.08B(1) with:**

During construction install mailboxes with temporary portable foundations authorized by the USPS.

**Add to the 1<sup>st</sup> paragraph of section 15- 2.08B(1):**

Work with the United States Postal Service (USPS) and the property owners/residents to ensure the temporary and permanent locations of the mailboxes are acceptable.

**Add to section 15-2.10B:**

Notify EID and the Engineer a minimum of 48 hours in advance of any work that will modify EID facilities.

For EID notifications, contact Skip Haskell at (530) 642-4120.

Positively locate all EID water valves and EID manholes prior to any activities that require their modification such that they can be located and raised after the placement of the HMA overlay.

Adjust EID water valve frames and covers by lowering existing frames before cold planing and raising to grade with new G5 valve box after paving and before striping.

The following EID water valve frames and covers have been identified within the limits of the project:

- 1 EA at Missouri Flat Road.
- 9 EA at Patterson Drive.

New valve box must be G5 per EID Standard Drawing W12 which is included as Exhibit E-1 of Appendix C.

Adjust EID sanitary sewer manhole frames and covers by lowering existing frames before cold planing and raising to grade after paving and before striping.

The following EID sanitary sewer frames and covers have been identified within the limits of the project:

- 26 EA at Patterson Drive.

Sanitary sewer frames and covers placed per EID Standard Drawing S09B which is included as Exhibit E-2 of Appendix C.

Comply with Caltrans and the most current EID Standards "Water, Sewer and Recycle Water Design and Construction Standards". In case of conflict between Caltrans and EID Standards, EID Standards govern. EID Standards can be found at:

<http://www.eid.org/home/showdocument?id=335>

Installation will require removing concrete collar, placement of concrete and HMA .

Use the same quality of HMA that is used for the HMA overlay as specified in section 39.

Payment for all work associated with adjusting EID water valve frames and covers, including the placement of HMA, is included in the bid item price for Adjust Frame and Cover to Grade (Water Valve) (EID Reimbursement).

Payment for all work associated with adjusting EID sanitary sewer frames and covers, including the placement of HMA, is included in the bid item price for Adjust Frame and Cover to Grade (Manhole) (EID Reimbursement).

~~~~~

DIVISION III GRADING

NOT USED

~~~~~

### **DIVISION IV SUBBASES AND BASES**

NOT USED

~~~~~

DIVISION V SURFACINGS AND PAVEMENTS

39 HOT MIX ASPHALT

Delete section 39 of the RSS dated 2-27-15.

Add to section 39-1.01A:

Produce and place HMA Type A under the Method construction process.

Refer to Exhibits B-1 through B-7 of Appendix C for additional details regarding HMA placement.

With the exception of the two transverse AC valley gutters on Patterson Drive within the Griffith intersection limits as shown in Exhibits B-1 and B-5 of Appendix C, you must place HMA such that the post construction surface will positively drain to existing drainage facilities. The work associated with the installation of the transverse valley gutters on Patterson Drive will be performed by others.

Add to section 39-1.01B:

processed RAP: RAP that has been fractionated.

substitution rate: Amount of RAP aggregate substituted for virgin aggregate in percent.

binder replacement: Amount of RAP binder in OBC in percent.

surface course: Upper 0.2 feet of HMA exclusive of OGFC.

Add to the end of the paragraph in section 39-1.02A:

as shown

Add to section 39-1.02C:

Asphalt binder used in HMA Type A must be PG 64-16.

Replace "less than 10 percent" in note "b" in the table in the 5th paragraph of section 39-1.02E with:

10 percent or less

Add to section 39-1.02E:

Aggregate used in HMA Type A must comply with ½ inch HMA Type A and B gradation.

Replace the paragraphs in section 39-1.02F with:

39-1.02F(1) General

You may produce HMA Type A or B using RAP. HMA produced using RAP must comply with the specifications for HMA, except aggregate quality specifications do not apply to RAP. You may substitute RAP at a substitution rate not exceeding 15 percent of the aggregate blend. Do not use RAP in OGFC and RHMA-G.

Assign the substitution rate of RAP aggregate for virgin aggregate with the JMF submittal. The JMF must include the percent of RAP used.

Provide enough space for meeting RAP handling requirements at your facility. Provide a clean, graded, well-drained area for stockpiles. Prevent material contamination and segregation.

If RAP is from multiple sources, blend the RAP thoroughly and completely. RAP stockpiles must be homogeneous.

Isolate the processed RAP stockpiles from other materials. Store processed RAP in conical or longitudinal stockpiles. Processed RAP must not be agglomerated or be allowed to congeal in large stockpiles.

39-1.02F(2) Substitution Rate of 15 Percent or Less

For a RAP substitution rate of 15 percent or less, you may stockpile RAP during the entire project.

Replace items 7 and 8 in the 5th paragraph of section 39-1.03A with:

7. Substitution rate by more than 5 percent if your assigned RAP substitution rate is 15 percent or less
8. Average binder content by more than 2 percent from the average binder content of the original processed RAP stockpile used in the mix design
9. Maximum specific gravity of processed RAP by more than ± 0.060 from the average maximum specific gravity of processed RAP reported on page 4 of your *Contractor Hot Mix Asphalt Design Data* form
10. Any material in the JMF

Replace the 1st paragraph of section 39-1.03B with:

Perform a mix design that produces HMA with the values for the quality characteristics shown in the following table:

HMA Mix Design Requirements

Quality characteristic	Test method	HMA type		
		A	B	RHMA-G
Air void content (%)	California Test 367	4.0	4.0	Section 39-1.03B
Voids in mineral aggregate (% min.) No. 4 grading 3/8" grading 1/2" grading 3/4" grading	California Test 367	17.0	17.0	--
		15.0	15.0	--
		14.0	14.0	18.0–23.0
		13.0	13.0	18.0–23.0
Voids filled with asphalt (%) No. 4 grading 3/8" grading 1/2" grading 3/4" grading	California Test 367	65.0–75.0	65.0–75.0	Note a
		65.0–75.0	65.0–75.0	
		65.0–75.0	65.0–75.0	
		65.0–75.0	65.0–75.0	
Dust proportion No. 4 and 3/8" gradings 1/2" and 3/4" gradings	California Test 367	0.6–1.2	0.6–1.2	Note a
		0.6–1.2	0.6–1.2	
Stabilometer value (min.) No. 4 and 3/8" gradings 1/2" and 3/4" gradings	California Test 366	30	30	--
		37	35	23

^a Report this value in the JMF submittal.

Replace item 4 in the list in the 1st paragraph of section 39-1.03C with:

4. JMF renewal on a *Caltrans Job Mix Formula Renewal* form, if applicable

Replace the 2nd paragraph of section 39-1.03E with:

Use the OBC specified on your *Contractor Hot Mix Asphalt Design Data* form. No adjustments to asphalt binder content are allowed. Based on your testing and production experience, you may submit an adjusted aggregate gradation TV on a *Contractor Job Mix Formula Proposal* form before verification testing. Aggregate gradation TV must be within the TV limits specified in the aggregate gradation tables.

Add between the 3rd and 4th paragraphs of section 39-1.03E:

Asphalt binder set point for HMA must be the OBC specified on your *Contractor Hot Mix Asphalt Design Data* form. When RAP is used, asphalt binder set point for HMA must be:

$$\text{Asphalt Binder Set Point} = \frac{\frac{BC_{OBC}}{\left(1 - \frac{BC_{OBC}}{100}\right)} - R_{RAP} \left[\frac{BC_{RAP}}{\left(1 - \frac{BC_{RAP}}{100}\right)} \right]}{100 + \frac{BC_{OBC}}{\left(1 - \frac{BC_{OBC}}{100}\right)}}$$

Where:

BC_{OBC} = optimum asphalt binder content, percent based on total weight of mix

R_{RAP} = RAP ratio by weight of aggregate

BC_{RAP} = asphalt binder content of RAP, percent based on total weight of RAP mix

Replace item 4 in the list in the 8th paragraph of section 39-1.03E with:

4. HMA quality specified in the table titled "HMA Mix Design Requirements" except:
 - 4.1. Air void content, design value ± 2.0 percent
 - 4.2. Voids filled with asphalt, report only
 - 4.3. Dust proportion, report only

Replace the 12th paragraph of section 39-1.03E with:

If tests on plant-produced samples do not verify the JMF, the Engineer notifies you and you must submit a new JMF or submit an adjusted JMF based on your testing. JMF adjustments may include a change in aggregate gradation TV within the TV limits specified in the aggregate gradation tables.

Replace the 14th paragraph of section 39-1.03E with:

A verified JMF is valid for 12 months.

Replace the last sentence in the 15th paragraph of section 39-1.03E with:

This deduction does not apply to verifications initiated by the Engineer or JMF renewal.

Add between the 1st and 2nd paragraphs of section 39-1.03F:

Target asphalt binder content on your *Contractor Job Mix Formula Proposal* form and the OBC specified on your *Contractor Hot Mix Asphalt Design Data* form must be the same.

Delete the 4th paragraph of section 39-1.03F.

Replace items 3 and 5 in the list in the 6th paragraph of section 39-1.03F with:

3. Engineer verifies each proposed JMF renewal within 20 days of receiving verification samples.

5. For each HMA type and aggregate gradation specified, the Engineer verifies at the Department's expense 1 proposed JMF renewal within a 12-month period.

Add between the 6th and 7th paragraphs of section 39-1.03F:

The most recent aggregate quality test results within the past 12 months may be used for verification of JMF renewal or the Engineer may perform aggregate quality tests for verification of JMF renewal.

Replace section 39-1.03G with:

39-1.03G Job Mix Formula Modification

For an accepted JMF, you may change asphalt binder source one time during production.

Submit your modified JMF request a minimum of 3 business days before production. Each modified JMF submittal must consist of:

1. Proposed modified JMF on Contractor Job Mix Formula Proposal form
2. Mix design records on *Contractor Hot Mix Asphalt Design Data* form for the accepted JMF to be modified
3. JMF verification on *Hot Mix Asphalt Verification* form for the accepted JMF to be modified
4. Quality characteristics test results for the modified JMF as specified in section 39-1.03B. Perform tests at the mix design OBC as shown on the *Contractor Asphalt Mix Design Data* form

With an accepted modified JMF submittal, the Engineer verifies each modified JMF within 5 business days of receiving all verification samples.

The Engineer verifies the modified JMF after the modified JMF HMA is placed on the project and verification samples are taken within the first 750 tons following sampling requirements in section 39-1.03E, "Job Mix Formula Verification." The Engineer tests verification samples for compliance with:

1. Stability as shown in the table titled "HMA Mix Design Requirements"
2. Air void content at design value ± 2.0 percent
3. Voids in mineral aggregate as shown in the table titled "HMA Mix Design Requirements"
4. Voids filled with asphalt, report only
5. Dust proportion, report only

If the modified JMF is verified, the Engineer revises your *Hot Mix Asphalt Verification* form to include the new asphalt binder source. Your revised form will have the same expiration date as the original form.

If a modified JMF is not verified, stop production and any HMA placed using the modified JMF is rejected.

The Engineer deducts \$2,000 from payments for each modified JMF verification.

Add to section 39-1.03:

39-1.03H Job Mix Formula Acceptance

You may start HMA production if:

1. The Engineer's review of the JMF shows compliance with the specifications.
2. The Department has verified the JMF within 12 months before HMA production.
3. The Engineer accepts the verified JMF.

Replace "3 days" in the 1st paragraph of section 39-1.04A with:

3 business days

Replace the 2nd sentence in the 2nd paragraph of section 39-1.04A with:

During production, take samples under California Test 125. You may sample HMA from:

Replace "batch" in the 2nd sentence in the 2nd paragraph of section 39-1.04C with:

lot. Each asphalt binder lot consists of 1 or multiple batches of combined asphalt binder, asphalt modifier, and CRM proportioned under section 39-1.02D.

Replace the 2nd paragraph of section 39-1.04E with:

For RAP substitution rate of 15 percent or less, sample RAP once daily.

Perform QC testing for processed RAP aggregate gradation under California Test 367, appendix B, and submit the results with the combined aggregate gradation.

Replace "5 days" in the 1st paragraph of section 39-1.06 with:

5 business days

Replace the 3rd paragraph of section 39-1.08A with:

During production, you may adjust hot or cold feed proportion controls for virgin aggregate and RAP.

Add to section 39-1.08A:

During production, asphalt binder set point for HMA Type A, HMA Type B, HMA Type C, and RHMA-G must be the OBC shown in *Contractor Hot Mix Asphalt Design Data* form. For OGFC, asphalt binder set point must be the OBC shown on *Caltrans Hot Mix Asphalt Verification* form. If RAP is used, asphalt binder set point for HMA must be calculated as specified in section 39-1.03E.

For RAP substitution rate of 15 percent or less, you may adjust the RAP by -5 percent.

You must request adjustments to the plant asphalt binder set point based on new RAP stockpiles average asphalt binder content. Do not adjust the HMA plant asphalt binder set point until authorized.

Replace the 1st item of the list in the 2nd paragraph of section 39-1.09D with:

1. Repair cracks ¼ inch and wider, spalls, and holes in the pavement. The repair of cracks as directed by the Engineer is change order work.

Replace section 39-1.11 with:

39-1.11 CONSTRUCTION

39-1.11A General

Do not place HMA on wet pavement or a frozen surface.

You may deposit HMA in a windrow and load it in the paver if:

1. Paver is equipped with a hopper that automatically feeds the screed

2. Loading equipment can pick up the windrowed material and deposit it in the paver hopper without damaging base material
3. Activities for deposit, pickup, loading, and paving are continuous
4. HMA temperature in the windrow does not fall below 260 degrees F

You may place HMA in 1 or more layers on areas less than 5 feet wide and outside the traveled way, including shoulders. You may use mechanical equipment other than a paver for these areas. The equipment must produce uniform smoothness and texture.

HMA handled, spread, or windrowed must not stain the finished surface of any improvement, including pavement.

Do not use petroleum products such as kerosene or diesel fuel to release HMA from trucks, spreaders, or compactors.

HMA must be free of:

1. Segregation
2. Coarse or fine aggregate pockets
3. Hardened lumps

Place additional HMA along the pavement's edge to conform to paved private roads and drives. Hand rake, if necessary, and compact the additional HMA to form a smooth conform taper.

39-1.11B Longitudinal Joints

39-1.11B(1) General

Longitudinal joints in the top layer must match specified lane edges. Alternate the longitudinal joint offsets in the lower layers at least 0.5 foot from each side of the specified lane edges. You may request other longitudinal joint placement patterns.

A vertical longitudinal joint of more than 0.15 ft is not allowed at any time between adjacent lanes open to traffic.

Place HMA on adjacent traveled way lanes so that at the end of each work shift the distance between the ends of HMA layers on adjacent lanes is from 5 to 10 feet. Place additional HMA along the transverse edge at each lane's end and along the exposed longitudinal edges between adjacent lanes. Hand rake and compact the additional HMA to form temporary conforms. You may place Kraft paper or another authorized bond breaker under the conform tapers to facilitate the taper removal when paving operations resume.

39-1.11B(2) Tapered Notched Wedge

Not Used

39-1.11C Widening Existing Pavement

If widening existing pavement, construct new pavement structure to match the elevation of the existing pavement's edge before placing HMA over the existing pavement.

39-1.11D Shoulders, Medians, and Other Road Connections

Until the adjoining through lane's top layer has been paved, do not pave the top layer of:

1. Shoulders
2. Tapers
3. Transitions
4. Road connections

5. Driveways
6. Curve widenings
7. Chain control lanes
8. Turnouts
9. Turn pockets

If the number of lanes changes, pave each through lane's top layer before paving a tapering lane's top layer. Simultaneous to paving a through lane's top layer, you may pave an adjoining area's top layer, including shoulders. Do not operate spreading equipment on any area's top layer until completing final compaction.

Pave shoulders and median borders adjacent to the lane before opening a lane to traffic.

39-1.11E Reserved

39-1.11F Compaction

Rolling must leave the completed surface compacted and smooth without tearing, cracking, or shoving. Complete finish rolling activities before the pavement surface temperature is:

1. Below 150 degrees F for HMA with unmodified binder
2. Below 140 degrees F for HMA with modified binder
3. Below 200 degrees F for RHMA-G

If a vibratory roller is used as a finish roller, turn the vibrator off.

Do not use a pneumatic-tired roller to compact RHMA-G.

For Standard and QC/QA construction processes, if 3/4-inch aggregate grading is specified, you may use a 1/2-inch aggregate grading if the specified total paved thickness is at least 0.15 foot and less than 0.20 foot thick.

Spread and compact HMA under sections 39-3.03 and 39-3.04 if any of the following applies:

1. Specified paved thickness is less than 0.15 foot.
2. Specified paved thickness is less than 0.20 foot and 3/4-inch aggregate grading is specified and used.
3. You spread and compact at:
 - 3.1. Asphalt concrete surfacing replacement areas
 - 3.2. Leveling courses
 - 3.3. Areas for which the Engineer determines conventional compaction and compaction measurement methods are impeded

Do not open new HMA pavement to public traffic until its mid-depth temperature is below 160 degrees F.

Replace the 1st paragraph of section 39-3.02A with:

The Department samples for acceptance testing and tests for the quality characteristics shown in the following table:

HMA Acceptance—Method Construction Process

Quality characteristic	Test method	HMA type			
		A	B	RHMA-G	OGFC
Aggregate gradation ^a	California Test 202	JMF ± tolerance ^b	JMF ± tolerance ^b	JMF ± tolerance ^b	JMF ± tolerance ^b
Sand equivalent (min) ^c	California Test 217	47	42	47	--
Asphalt binder content (%)	California Test 379 or 382	JMF±0.40	JMF±0.40	JMF ± 0.40	JMF ± 0.40
HMA moisture content (% max)	California Test 226 or 370	1.0	1.0	1.0	1.0
Stabilometer value (min) ^c No. 4 and 3/8" gradings 1/2" and 3/4" gradings	California Test 366	30	30	--	--
		37	35	23	--
Percent of crushed particles Coarse aggregate (% min) One fractured face Two fractured faces Fine aggregate (% min) (Passing no. 4 sieve and retained on no. 8 sieve.) One fractured face	California Test 205	90	25	--	90
		75	--	90	75
		70	20	70	90
Los Angeles Rattler (% max) Loss at 100 rev. Loss at 500 rev.	California Test 211	12	--	12	12
		45	50	40	40
Air void content (%) ^{c, d}	California Test 367	4 ± 2	4 ± 2	TV ± 2	--
Fine aggregate angularity (% min) ^e	California Test 234	45	45	45	--
Flat and elongated particles (% max by weight @ 5:1)	California Test 235	Report only	Report only	Report only	Report only
Voids filled with asphalt (%) ^f No. 4 grading 3/8" grading 1/2" grading 3/4" grading	California Test 367	65.0–75.0	65.0–75.0	Report only	--
		65.0–75.0	65.0–75.0		
		65.0–75.0	65.0–75.0		
		65.0–75.0	65.0–75.0		
Voids in mineral aggregate (% min) ^f No. 4 grading 3/8" grading 1/2" grading 3/4" grading	California Test 367	17.0	17.0	--	--
		15.0	15.0	--	--
		14.0	14.0	18.0–23.0	18.0–23.0
		13.0	13.0	18.0–23.0	18.0–23.0
Dust proportion [†] No. 4 and 3/8" gradings 1/2" and 3/4" gradings	California Test 367	0.6–1.2	0.6–1.2	Report only	--
		0.6–1.2	0.6–1.2		
Smoothness	Section 39-1.12	12-foot straight-edge	12-foot straight-edge	12-foot straight-edge	12-foot straight-edge
Asphalt binder	Various	Section 92	Section 92	Section 92	Section 92
Asphalt modifier	Various	--	--	Section	Section

				39-1.02D	39-1.02D
CRM	Various	--	--	Section 39-1.02D	Section 39-1.02D

^a The Engineer determines combined aggregate gradations containing RAP under California Test 367.

^b The tolerances must comply with the allowable tolerances in section 39-1.02E.

^c The Engineer reports the average of 3 tests from a single split sample.

^d The Engineer determines the bulk specific gravity of each lab-compacted briquette under California Test 308, Method A, and theoretical maximum specific gravity under California Test 309.

^e The Engineer waives this specification if HMA contains 10 percent or less of nonmanufactured sand by weight of total aggregate. Manufactured sand is fine aggregate produced by crushing rock or gravel.

^f Report only.

Replace "280 degrees F" in item 2 in the list in the 6th paragraph of section 39-3.04 with:

285 degrees F

~~~~~

**DIVISION VI STRUCTURES**

NOT USED

~~~~~

DIVISION VII DRAINAGE

NOT USED

~~~~~

**DIVISION VIII MISCELLANEOUS CONSTRUCTION**

NOT USED

~~~~~

DIVISION IX TRAFFIC CONTROL FACILITIES

84 TRAFFIC STRIPES AND PAVEMENT MARKINGS

Add to section 84-1.01:

Replace all traffic stripes and pavement markings within the limits of cold planing activities as specified in section 15 of these Special Provisions with thermoplastic traffic stripes and thermoplastic pavement markings, respectively.

For Missouri Flat Road, the traffic stripes and pavement marking details are shown in Exhibit C of Appendix C of these Special Provisions.

For Patterson Drive, place centerline striping per Detail 22 on Standard Plan A20A, and place edge line striping per Detail 27B on Standard Plan A20B.

For Patterson Drive, place "STOP" and "AHEAD" pavement markings per Standard Plan A24D and place limit line pavement markings per Revised Standard Plan A24E.

Add to section 64-1.03:

Do not place traffic stripes or pavement markings until all other construction activities are complete.



85 PAVEMENT MARKERS

Add to section 85-1.01:

For Missouri Flat Road, pavement marker details are shown in Exhibit C of Appendix C of these Special Provisions.

For Patterson Drive, place pavement markers per Detail 22 on Standard Plan A20A.



86 ELECTRICAL SYSTEMS

Add to the end of the 1st paragraph of the RSS for section 86-1.01:

This work is shown on plan sheets on Exhibits D-1 and D-2 of Appendix C. The work involved in the Modify Signal and Lighting bid item is shown on these exhibits except for the following bid item:

- 1. Maintaining the existing traffic management system during construction

Replace "15" in the 1st paragraph of the RSS for section 86-1.03 with:

7

Replace the 3rd paragraph of section 86-1.06A with:

Traffic signal system shutdowns are limited to periods between the hours of 8:00 p.m. and 6:00 a.m.

Replace "Reserved" in section 86-1.06B with:

Traffic Management System (TMS) elements include, but are not limited to ramp metering (RM) system, communication system, traffic monitoring stations, video image vehicle detection system (VIVDS), microwave vehicle detection system (MVDS), loop detection system, changeable message sign (CMS) system, extinguishable message sign (EMS) system, highway advisory radio (HAR) system, closed circuit television (CCTV) camera system, roadway weather information system (RWIS), visibility sensor, and fiber optic system.

Existing TMS elements, including detection systems, shown and located within the project limits must remain in place and be protected from damage. If the construction activities require existing TMS elements to be nonoperational or off line, and if temporary or portable TMS elements are not shown, the Contractor must provide for temporary or portable TMS elements. The Contractor must receive authorization on the type of temporary or portable TMS elements and installation method.

Before work is performed, the Engineer, the Contractor, and the Department's Traffic Operations Electrical representatives must jointly conduct a pre-construction operational status check of all existing TMS elements and each element's communication status with the Traffic Management Center (TMC), including existing TMS elements not shown and elements that may not be impacted by the Contractor's activities. The Department's Traffic Operations Electrical representatives will certify the TMS elements' location and status, and provide a copy of the certified list of the existing TMS elements within the project

limits to the Contractor. The status list will include the operational, defined as having full functionality, and the nonoperational components.

The Contractor must obtain authorization at least 72 hours before interrupting existing TMS elements' communication with the TMC that will result in the elements being nonoperational or off line. The Contractor must notify the Engineer at least 72 hours before starting excavation activities.

Traffic monitoring stations and their associated communication systems, which were verified to be operational during the pre-construction operational status check, must remain operational on freeway/highway mainline at all times, except:

1. For a duration of up to 15 days on any continuous segment of the freeway/highway longer than 3 miles
2. For a duration of up to 60 days on any continuous segment of the freeway/highway shorter than 3 miles

If the construction activities require existing detection systems to be nonoperational or off line for a longer time period or the spacing between traffic monitoring stations is more than the specified criteria above, and temporary or portable detection operations are not shown, the Contractor must provide provisions for temporary or portable detection operations. The Contractor must receive authorization on the type of detection and installation before installing the temporary or portable detection.

If existing TMS elements shown or identified during the pre-construction operational status check, except traffic monitoring stations, are damaged or fail due to the Contractor's activity, where the elements are not fully functional, the Engineer must be notified immediately. If the Contractor is notified by the Engineer that existing TMS elements have been damaged, have failed or are not fully functional due to the Contractor's activity, the damaged or failed TMS elements, excluding structure-related elements, must be repaired or replaced, at the Contractor's expense, within 24 hours. For a structure-related elements, the Contractor must install temporary or portable TMS elements within 24 hours. For nonstructure-related TMS elements, the Engineer may authorize temporary or portable TMS elements for use during the construction activities.

The Contractor must demonstrate that repaired or replaced elements operate in a manner equal to or better than the replaced equipment. If the Contractor fails to perform required repairs or replacement work, the Department may perform the repair or replacement work and the cost will be deducted from monies due to the Contractor.

A TMS element must be considered nonoperational or off line for the duration of time that active communications with the TMC is disrupted, resulting in messages and commands not transmitted from or to the TMS element.

The Contractor must provide provisions for replacing existing TMS elements within the project limits, including detection systems that were not identified on the plans or during the pre-construction operational status check that became damaged due to the Contractor's activities.

If the pre-construction operational status check identified existing TMS elements, then the Contractor, the Engineer, and the Department's Traffic Operations Electrical representatives must jointly conduct a post construction operational status check of all existing TMS elements and each element's communication status with the TMC. The Department's Traffic Operations Electrical representatives will certify the TMS elements' status and provide a copy of the certified list of the existing TMS elements within the project limits to the Contractor. The status list will include the operational, defined as having full functionality, and the nonoperational components. TMS elements that cease to be functional between pre and post construction status checks must be repaired at the Contractor's expense.

The Engineer will authorize the schedule for final replacement, the replacement methods and the replacement elements, including element types and installation methods before repair or replacement work is performed. The final TMS elements must be new and of equal or better quality than the existing TMS elements.

If no electrical work exists on the project and no TMS elements are identified within the project limits, the pre-construction operational status check is change order work.

Furnishing and installing temporary or portable TMS elements that are not shown, but are required when an existing TMS element becomes nonoperational or off line due to construction activities, is change order work.

Furnishing and installing temporary or portable TMS elements and replacing TMS elements that are not shown nor identified during the pre-construction operational status check and were damaged by construction activities is change order work.

If the Contractor is required to submit provisions for the replacement of TMS elements that were not identified, submitting the provisions is change order work.

Add to section 86-2.05A:

Conduit installed underground must be Type 1 or Type 3.

Add to section 86-2.05B:

The conduit in a foundation and between a foundation and the nearest pull box must be Type 1.

Add to section 86-2.05C:

After conductors have been installed, the ends of the conduits must be sealed with an authorized type of sealing compound.

At those locations where conduit is required to be installed under pavement and underground facilities designated as high priority subsurface installation under Govt Code § 4216 et seq. exist, conduit must be placed by the trenching in pavement method under section 86-2.05C.

At other locations where conduit is required to be installed under pavement and if a delay to vehicles will not exceed 5 minutes, conduit may be installed by the trenching in pavement method.

Replace the 3rd paragraph in section 86-2.06A(2) of the RSS for section 86-2.06 with:

In a ground or sidewalk area, embed the bottom of a pull box in crushed rock.

Add to RSS section 86-2.06C:

The steel lid for a traffic pull box must be welded to a Z-bar frame.

Add to section 86-2.08A:

Secure conductors and cables to the projecting end of the conduit in pull boxes.

Replace the 1st paragraph of section 86-2.09E with:

Splices must be insulated by "Method B."

Delete the 6th and 7th paragraphs of section 86-2.09E.

Add to section 86-5.01A(1):

Loop wire must be Type 2.

Loop detector lead-in cable must be Type B .

Slots must be filled with elastomeric sealant or hot-melt rubberized asphalt sealant.

You may use a Type E loop where a Type A or a Type B loop is shown.

For Type E detector loops, sides of the slot must be vertical and the minimum radius of the slot entering and leaving the circular part of the loop must be 1-1/2 inches. Slot width must be a maximum of 5/8 inch. Loop wire for circular loops must be Type 2. Slots of circular loops must be filled with elastomeric sealant or hot-melt rubberized asphalt sealant.

The depth of the loop sealant above the top of the uppermost loop wire in the sawed slots must be 1 inch, minimum.



DIVISION X MATERIALS

88 GEOSYNTHETICS

Add to section 88-1.02L:

The paving grid used for the geosynthetic pavement interlayer (paving grid) must be Class II. Geosynthetic pavement interlayer (paving grid) is to be placed after cold planing operations and prior to placement of new HMA at all locations on Patterson Drive and Missouri Flat Road.



DIVISION XI BUILDING CONSTRUCTION

NOT USED



APPENDIX A
REVISED STANDARD SPECIFICATIONS

REVISED STANDARD SPECIFICATIONS DATED 02-27-15

ORGANIZATION

Revised standard specifications are under headings that correspond with the main-section headings of the *Standard Specifications*. A main-section heading is a heading shown in the table of contents of the *Standard Specifications*. A date under a main-section heading is the date of the latest revision to the section.

Each revision to the *Standard Specifications* begins with a revision clause that describes or introduces a revision to the *Standard Specifications*. For a revision clause that describes a revision, the date on the right above the clause is the publication date of the revision. For a revision clause that introduces a revision, the date on the right above a revised term, phrase, clause, paragraph, or section is the publication date of the revised term, phrase, clause, paragraph, or section. For a multiple-paragraph or multiple-section revision, the date on the right above a paragraph or section is the publication date of the paragraphs or sections that follow.

Any paragraph added or deleted by a revision clause does not change the paragraph numbering of the *Standard Specifications* for any other reference to a paragraph of the *Standard Specifications*.

^.....^

ORGANIZATIONAL REVISIONS

07-19-13

Transfer section 36 from division IV to division V.

^.....^

DIVISION I GENERAL PROVISIONS

1 GENERAL

02-27-15

Replace "current" in the 2nd paragraph of section 1-1.05 with:

04-20-12

most recent

Add to the 4th paragraph of section 1-1.05:

04-20-12

Any reference directly to a revised standard specification section is for convenience only. Lack of a direct reference to a revised standard specification section does not indicate a revised standard specification for the section does not exist.

Replace "MSDS" in the 1st table in section 1-1.06 with:

10-17-14

MSDS^b

Add to the 1st table in section 1-1.06:

10-17-14

LCS	Department's lane closure system
POC	pedestrian overcrossing
QSD	qualified SWPPP developer
QSP	qualified SWPPP practitioner
SDS	safety data sheet
TRO	time-related overhead
WPC	water pollution control

Add to the notes of the 1st table in section 1-1.06:

10-17-14

^bInterpret a reference to MSDS as a reference to SDS under 29 CFR 1910.1200.

06-20-12

Delete the abbreviation and its meaning for *UDBE* in the 1st table of section 1-1.06.

10-19-12

Delete "Contract completion date" and its definition in section 1-1.07B.

10-19-12

Delete "critical delay" and its definition in section 1-1.07B.

Replace "day" and its definition in section 1-1.07B with:

10-19-12

day: 24 consecutive hours running from midnight to midnight; calendar day.

1. **business day:** Day on the calendar except a Saturday and a holiday.
2. **working day:** Time measure unit for work progress. A working day is any 24-consecutive-hour period except:
 - 2.1. Saturday and holiday.
 - 2.2. Day during which you cannot perform work on the controlling activity for at least 50 percent of the scheduled work shift with at least 50 percent of the scheduled labor and equipment due to any of the following:

- 2.2.1. Adverse weather-related conditions.
- 2.2.2. Maintaining traffic under the Contract.
- 2.2.3. Suspension of a controlling activity that you and the Engineer agree benefits both parties.
- 2.2.4. Unanticipated event not caused by either party such as:
 - 2.2.4.1. Act of God.
 - 2.2.4.2. Act of a public enemy.
 - 2.2.4.3. Epidemic.
 - 2.2.4.4. Fire.
 - 2.2.4.5. Flood.
 - 2.2.4.6. Governor-declared state of emergency.
 - 2.2.4.7. Landslide.
 - 2.2.4.8. Quarantine restriction.
- 2.2.5. Issue involving a third party, including:
 - 2.2.5.1. Industry or area-wide labor strike.
 - 2.2.5.2. Material shortage.
 - 2.2.5.3. Freight embargo.
 - 2.2.5.4. Jurisdictional requirement of a law enforcement agency.
 - 2.2.5.5. Workforce labor dispute of a utility or nonhighway facility owner resulting in a nonhighway facility rearrangement not described and not solely for the Contractor's convenience. Rearrangement of a nonhighway facility includes installation, relocation, alteration, or removal of the facility.
- 2.3. Day during a concurrent delay.
- 3. **original working days:**
 - 3.1. Working days to complete the work shown on the *Notice to Bidders* for a non-cost plus time based bid.
 - 3.2. Working days bid to complete the work for a cost plus time based bid.

Where working days is specified without the modifier "original" in the context of the number of working days to complete the work, interpret the number as the number of original working days as adjusted by any time adjustment.

Replace "Contract" in the definition of "early completion time" in section 1-1.07B with:

10-19-12

work

Replace "excusable delay" and its definition in section 1-1.07B with:

10-19-12

delay: Event that extends the completion of an activity.

1. **excusable delay:** Delay caused by the Department and not reasonably foreseeable when the work began such as:
 - 1.1. Change in the work
 - 1.2. Department action that is not part of the Contract
 - 1.3. Presence of an underground utility main not described in the Contract or in a location substantially different from that specified
 - 1.4. Described facility rearrangement not rearranged as described, by the utility owner by the date specified, unless the rearrangement is solely for the Contractor's convenience
 - 1.5. Department's failure to obtain timely access to the right-of-way
 - 1.6. Department's failure to review a submittal or provide notification in the time specified
2. **critical delay:** Excusable delay that extends the scheduled completion date
3. **concurrent delay:** Occurrence of at least 2 of the following events in the same period of time, either partially or entirely:
 - 3.1. Critical delay
 - 3.2. Delay to a controlling activity caused by you
 - 3.3. Non-working day

Replace "project" in the definition of "scheduled completion date" in section 1-1.07B with:

10-19-12

work

Add to section 1-1.07B:

10-19-12

Contract time: Number of original working days as adjusted by any time adjustment.

06-20-12

Disadvantaged Business Enterprise: Disadvantaged Business Enterprise as defined in 49 CFR 26.5.

Replace "PO BOX 911" in the District 3 mailing address in the table in section 1-1.08 with:

04-20-12

703 B ST

Replace the Web site for the Department of General Services, Office of Small Business and DVBE Services in the table in section 1-1.11 with:

11-15-13

<http://www.dgs.ca.gov/dgs/ProgramsServices/BusServices.aspx>

The *Standard Specifications* and *Standard Plans* may be viewed at the Bidders' Exchange website and may be purchased at the Publication Distribution Unit.

10-17-14

2-1.06B Supplemental Project Information

The Department makes supplemental information available as specified in the special provisions.

Logs of test borings are supplemental project information.

If an *Information Handout* or cross sections are available, you may view them at the Contract Plans and Special Provisions link at the Bidders' Exchange website.

If rock cores are available, you may view them by sending a request to Coreroom@dot.ca.gov.

If other supplemental project information is available for inspection, you may view it by phoning in a request.

Make your request at least 7 days before viewing. Include in your request:

1. District-County-Route
2. Contract number
3. Viewing date
4. Contact information, including telephone number

For rock cores, also include the bridge number in your request.

If bridge as-built drawings are available:

1. For a project in District 1 through 6 or 10, you may request them from the Office of Structure Maintenance and Investigations, fax (916) 227-8357
2. For a project in District 7, 8, 9, 11, or 12, you may request them from the Office of Structure Maintenance and Investigations, fax (916) 227-8357, and they are available at the Office of Structure Maintenance and Investigations, Los Angeles, CA, telephone (213) 897-0877

As-built drawings may not show existing dimensions and conditions. Where new construction dimensions are dependent on existing bridge dimensions, verify the field dimensions and adjust dimensions of the work to fit existing conditions.

2-1.06C–2-1.06D Reserved

2-1.07 JOB SITE AND DOCUMENT EXAMINATION

Examine the job site and bid documents. Notify the Department of apparent errors and patent ambiguities in the plans, specifications, and Bid Item List. Failure to do so may result in rejection of a bid or rescission of an award.

Bid submission is your acknowledgment that you have examined the job site and bid documents and are satisfied with:

1. General and local conditions to be encountered
2. Character, quality, and scope of work to be performed
3. Quantities of materials to be furnished
4. Character, quality, and quantity of surface and subsurface materials or obstacles
5. Requirements of the contract

2-1.08 RESERVED**2-1.09 BID ITEM LIST**

Submit a bid based on the bid item quantities the Department shows on the Bid Item List.

02-27-15

2-1.10 SUBCONTRACTOR LIST

On the Subcontractor List form, list each subcontractor to perform work in an amount in excess of 1/2 of 1 percent of the total bid or \$10,000, whichever is greater (Pub Cont Code § 4100 et seq.).

For each subcontractor listed, the Subcontractor List form must show:

1. Business name and the location of its place of business.
2. California contractor license number for a non-federal-aid contract.
3. Public works contractor registration number
4. Portion of work it will perform. Show the portion of the work by:
 - 4.1. Bid item numbers for the subcontracted work
 - 4.2. Percentage of the subcontracted work for each bid item listed
 - 4.3. Description of the subcontracted work if the percentage of the bid item listed is less than 100 percent

02-21-14

2-1.11 RESERVED

01-23-15

2-1.12 DISADVANTAGED BUSINESS ENTERPRISES**2-1.12A General**

Section 2-1.12 applies to a federal-aid contract.

Under 49 CFR 26.13(b):

The contractor, sub recipient or subcontractor shall not discriminate on the basis of race, color, national origin, or sex in the performance of this contract. The contractor shall carry out applicable requirements of 49 CFR part 26 in the award and administration of DOT-assisted contracts. Failure by the contractor to carry out these requirements is a material breach of this contract, which may result in the termination of this contract or such other remedy as the recipient deems appropriate, which may include, but is not limited to:

- (1) Withholding monthly progress payments;
- (2) Assessing sanctions;
- (3) Liquidated damages; and/or
- (4) Disqualifying the contractor from future bidding as non-responsible.

Include this assurance in each subcontract you sign with a subcontractor.

2-1.12B Disadvantaged Business Enterprise Goal

2-1.12B(1) General

Section 2-1.12B applies if a DBE goal is shown on the *Notice to Bidders*.

The Department shows a goal for DBEs to comply with the DBE program objectives provided in 49 CFR 26.1.

Make work available to DBEs and select work parts consistent with available DBEs, including subcontractors, suppliers, service providers, and truckers.

Meet the DBE goal shown on the *Notice to Bidders* or demonstrate that you made adequate good faith efforts to meet this goal.

You are responsible to verify at bid opening the DBE firm is certified as a DBE by the California Unified Certification Program and possess the work codes applicable to the type of work the firm will perform on the Contract.

Determine that selected DBEs perform a commercially useful function for the type of work the DBE will perform on the Contract as provided in 49 CFR 26.55(c)(1)–(4). Under 49 CFR 26.55(c)(1)–(4), the DBE must be responsible for the execution of a distinct element of work and must carry out its responsibility by actually performing, managing, and supervising the work.

All DBE participation will count toward the Department's federally-mandated statewide overall DBE goal.

Credit for materials or supplies you purchase from DBEs will be evaluated on a contract-by-contract basis and counts toward the goal in the following manner:

1. 100 percent if the materials or supplies are obtained from a DBE manufacturer.
2. 60 percent if the materials or supplies are obtained from a DBE regular dealer.
3. Only fees, commissions, and charges for assistance in the procurement and delivery of materials or supplies, if they are obtained from a DBE that is neither a manufacturer nor regular dealer. 49 CFR 26.55 defines "manufacturer" and "regular dealer."

You receive credit toward the goal if you employ a DBE trucking company that is performing a commercially useful function. The Department uses the following factors in determining whether a DBE trucking company is performing a commercially useful function:

- The DBE must be responsible for the management and supervision of the entire trucking operation for which it is responsible on a particular contract, and there cannot be a contrived arrangement for the purpose of meeting DBE goals.
- The DBE must itself own and operate at least one fully licensed, insured, and operational truck used on the contract.
- The DBE receives credit for the total value of the transportation services it provides on the Contract using trucks it owns, insures, and operates using drivers it employs.
- The DBE may lease trucks from another DBE firm, including an owner-operator who is certified as a DBE. The DBE who leases trucks from another DBE receives credit for the total value of the transportation services the lessee DBE provides on the Contract.
- The DBE may lease trucks without drivers from a non-DBE truck leasing company. If the DBE leases trucks from a non-DBE truck leasing company and uses its own employees as drivers, it is entitled to credit for the total value of these hauling services.
- A lease must indicate that the DBE has exclusive use of and control over the truck. This does not preclude the leased truck from working for others during the term of the lease with the consent of the DBE, so long as the lease gives the DBE absolute priority for use of the leased truck. Leased trucks must display the name and identification number of the DBE.

2-1.12B(2) DBE Commitment Submittal

Submit DBE information under section 2-1.33.

Submit written confirmation from each DBE shown on the DBE Commitment form stating that it will be participating in the Contract in the type and amount of work shown on the form. If a DBE is participating as a joint venture partner, submit a copy of the joint venture agreement.

2-1.12B(3) DBE Good Faith Efforts Submittal

You can meet the DBE requirements by either documenting commitments to DBEs to meet the Contract goal or by documenting adequate good faith efforts to meet the Contract goal. An adequate good faith effort means that the bidder must show that it took all necessary and reasonable steps to achieve a DBE goal that, by their scope, intensity, and appropriateness to the objective, could reasonably be expected to meet the DBE goal.

If you have not met the DBE goal, complete and submit the DBE Good Faith Efforts Documentation form under section 2-1.33 showing that you made adequate good faith efforts to meet the goal. Only good faith efforts directed toward obtaining participation by DBEs are considered.

Submit good faith efforts documentation within the specified time to protect your eligibility for award of the contract in the event the Department finds that the DBE goal has not been met.

Refer to 49 CFR 26 app A for guidance regarding evaluation of good faith efforts to meet the DBE goal.

The Department considers DBE commitments of other bidders in determining whether the low bidder made good faith efforts to meet the DBE goal.

02-21-14

2-1.13–2-1.14 RESERVED

2-1.15 DISABLED VETERAN BUSINESS ENTERPRISES

2-1.15A General

Section 2-1.15 applies to a non-federal-aid contract.

Take necessary and reasonable steps to ensure that DVBEs have the opportunity to participate in the Contract.

Comply with Mil & Vet Code § 999 et seq.

2-1.15B Projects \$5 Million or Less

Section 2-1.15B applies to a project with an estimated cost of \$5 million or less.

Make work available to DVBEs and select work parts consistent with available DVBE subcontractors and suppliers.

Meet the goal shown on the *Notice to Bidders*.

Complete and submit the Certified DVBE Summary form under section 2-1.33. List all DVBE participation on this form.

If a DVBE joint venture is used, submit the joint venture agreement with the Certified DVBE Summary form.

List each 1st-tier DVBE subcontractor on the Subcontractor List form regardless of percentage of the total bid.

2-1.15C Projects More Than \$5 Million

2-1.15C(1) General

Section 2-1.15C applies to a project with an estimated cost of more than \$5 million.

The Department encourages bidders to obtain DVBE participation to ensure the Department achieves its State-mandated overall DVBE goal.

If you obtain DVBE participation:

1. Complete and submit the Certified DVBE Summary form under section 2-1.33. List all DVBE participation on this form.
2. List each 1st tier DVBE subcontractor in the Subcontractor List form regardless of percentage of the total bid.

If a DVBE joint venture is used, submit the joint venture agreement with the Certified DVBE Summary form.

2-1.15C(2) DVBE Incentive

The Department grants a DVBE incentive to each bidder who achieves a DVBE participation of 1 percent or greater (Mil & Vet Code 999.5 and Code of Regs § 1896.98 et seq.).

To receive this incentive, submit the Certified DVBE Summary form under section 2-1.33.

Bidders other than the apparent low bidder, the 2nd low bidder, and the 3rd low bidder may be required to submit the Certified DVBE Summary form if the bid ranking changes. If the Department requests a Certified DVBE Summary form from you, submit the completed form within 4 business days of the request.

2-1.15C(3) Incentive Evaluation

The Department applies the small business and non–small business preference during bid verification and proceeds with the evaluation specified below for DVBE incentive.

The DVBE incentive is a reduction, for bid comparison only, in the total bid submitted by the lesser of the following amounts:

1. Percentage of DVBE achievement rounded to 2 decimal places of the verified total bid of the low bidder
2. 5 percent of the verified total bid of the low bidder
3. \$250,000

The Department applies DVBE incentive and determines whether bid ranking changes.

A non–small business bidder cannot displace a small business bidder. However, a small business bidder with higher DVBE achievement can displace another small business bidder.

The Department proceeds with awarding the contract to the new low bidder and posts the new verified bid results at the Department's Web site.

2-1.16–2-1.17 RESERVED

2-1.18 SMALL BUSINESS AND NON–SMALL BUSINESS SUBCONTRACTOR PREFERENCES

2-1.18A General

Section 2-1.18 applies to a non-federal-aid contract.

The Department applies small business preferences and non–small business preferences under Govt Code § 14835 et seq. and 2 CA Code of Regs § 1896 et seq.

Any contractor, subcontractor, supplier, or service provider who qualifies as a small business is encouraged to apply for certification as a small business by submitting its application to the Department of General Services, Office of Small Business and DVBE Services.

Contract award is based on the total bid, not the reduced bid.

2-1.18B Small Business Preference

The Department allows a bidder certified as a small business by the Department of General Services, Office of Small Business and DVBE Services, a preference if:

1. Bidder submitted a completed Request for Small Business Preference or Non–Small Business Preference form with its bid
2. Low bidder did not request the preference or is not certified as a small business

The bidder's signature on the Request for Small Business Preference or Non–Small Business Preference form certifies that the bidder is certified as a small business at the date and time of bid or has submitted a complete application to the Department of General Services. The complete application and any required substantiating documentation must be received by the Department of General Services by 5:00 p.m. on the bid opening date.

The Department of General Services determines whether a bidder was certified on the bid opening date. The Department of Transportation confirms the bidder's status as a small business before applying the small business preference.

The small business preference is a reduction for bid comparison in the total bid submitted by the small business contractor by the lesser of the following amounts:

1. 5 percent of the verified total bid of the low bidder
2. \$50,000

If the Department determines that a certified small business bidder is the low bidder after the application of the small business preference, the Department does not consider a request for non–small business preference.

2-1.18C Non–Small Business Subcontractor Preference

The Department allows a bidder not certified as a small business by the Department of General Services, Office of Small Business and DVBE Services, a preference if:

1. Bidder submitted a completed Request for Small Business Preference or Non–Small Business Preference form with its bid
2. Certified Small Business Listing for the Non–Small Business Preference form shows that you are subcontracting at least 25 percent to certified small businesses

Each listed subcontractor and supplier must be certified as a small business at the date and time of bid or must have submitted a complete application to the Department of General Services. The complete application and any required substantiating documentation must be received by the Department of General Services by 5:00 p.m. on the bid opening date.

The non–small business subcontractor preference is a reduction for bid comparison in the total bid submitted by the non–small business contractor requesting the preference by the lesser of the following amounts:

1. 5 percent of the verified total bid of the low bidder
2. \$50,000

2-1.19–2-1.26 RESERVED

2-1.27 CALIFORNIA COMPANIES

Section 2-1.27 applies to a non-federal-aid contract.

Under Pub Cont Code § 6107, the Department gives preference to a "California company," as defined, for bid comparison purposes over a nonresident contractor from any state that gives or requires a preference to be given to contractors from that state on its public entity construction contracts.

Complete a California Company Preference form.

The California company reciprocal preference amount is equal to the preference amount applied by the state of the nonresident contractor with the lowest responsive bid unless the California company is eligible for a small business preference or a non–small business subcontractor preference, in which case the preference amount is the greater of the two, but not both.

If the low bidder is not a California company and a California company's bid with reciprocal preference is equal to or less than the lowest bid, the Department awards the contract to the California company on the basis of its total bid.

2-1.28 RESERVED

2-1.29 OPT OUT OF PAYMENT ADJUSTMENTS FOR PRICE INDEX FLUCTUATIONS

You may opt out of the payment adjustments for price index fluctuations specified in section 9-1.07. To opt out, submit a completed Opt Out of Payment Adjustments for Price Index Fluctuations form under section 2-1.33.

2-1.30–2-1.32 RESERVED

02-27-15

2-1.33 BID DOCUMENT COMPLETION AND SUBMITTAL

2-1.33A General

Complete the forms in the *Bid* book.

Use the forms provided by the Department except as otherwise specified for a bidder's bond.

Do not fax forms except for the copies of forms with the public works contractor registration number submitted after the time of bid. Fax these copies to (916) 227-6282.

Submit the forms and copies of the forms to the Office Engineer.

Failure to submit the forms and information as specified may result in a nonresponsive bid.

If an agent other than the authorized corporate officer or a partnership member signs the bid, file a Power of Attorney with the Department either before opening bids or with the bid. Otherwise, the bid may be nonresponsive.

2-1.33B Electronic Bids

Section 2-1.33B applies to electronic bids.

For an electronic bid, complete and submit the electronic portion of the *Bid* book under the *Electronic Bidding Guide* at the Bidders' Exchange website and submit the paper forms as specified for a paper bid.

Your authorized digital signature is your confirmation of and agreement to all certifications and statements contained in the *Bid* book.

On forms and certifications that you submit through the electronic bidding service, you agree that each form and certification where a signature is required is deemed as having your signature.

2-1.33C Paper Bids

Section 2-1.33C applies to paper bids.

Submit your bid and any *Bid* book forms after you submit your bid:

1. Under sealed cover
2. Marked as a bid
3. Identifying the contract number and the bid opening date

2-1.33D Bid Form Submittal Schedules

2-1.33D(1) General

The *Bid* book includes forms specific to the contract. The deadlines for the submittal of the forms vary depending on the requirements of each contract. Determine the requirements of the contract and submit the forms based on the applicable schedule specified in section 2-1.33D.

Bid forms and information on the form that are due after the time of bid may be submitted at the time of bid.

2-1.33D(2) Federal-Aid Contracts

2-1.33D(2)(a) General

Section 2-1.33D(2) applies to a federal-aid contract.

2-1.33D(2)(b) Contracts with a DBE Goal

Section 2-1.33D(2)(b) applies if a DBE goal is shown on the *Notice to Bidders*,

Submit the bid forms according to the schedule shown in the following table:

**Bid Form Submittal Schedule for a
Federal-Aid Contract with a DBE Goal**

Form	Submittal deadline
Bid to the Department of Transportation	Time of bid except for the public works contractor registration number
Copy of the Bid to the Department of Transportation as submitted at the time of bid with the public works contractor registration number	10 days after bid opening
Subcontractor List	Time of bid except for the public works contractor registration number
Copy of the Subcontractor List as submitted at the time of bid with the public works contractor registration number	10 days after bid opening
Small Business Status	Time of bid
Opt Out of Payment Adjustments for Price Index Fluctuations ^a	Time of bid
DBE Commitment	No later than 4 p.m. on the 4th business day after bid opening
DBE Good Faith Efforts Documentation	No later than 4 p.m. on the 4th business day after bid opening

^aSubmit only if you choose the option.

2-1.33D(2)(c) Contracts without a DBE Goal

Reserved

2-1.33D(2)(d)–2-1.33D(2)(h) Reserved

2-1.33D(3) Non-Federal-Aid Contracts

2-1.33D(3)(a) General

Section 2-1.33D(3) applies to non-federal-aid contracts.

2-1.33D(3)(b) Contracts with a DVBE Goal

Section 2-1.33D(3)(b) applies if a DVBE goal is shown on the *Notice to Bidders*.

Submit the bid forms according to the schedule shown in the following table:

**Bid Form Submittal Schedule for a
Non-Federal-Aid Contract with a DVBE Goal**

Form	Submittal deadline
Bid to the Department of Transportation	Time of bid except for the public works contractor registration number for a joint-venture contract
For a joint-venture contract, copy of the Bid to the Department of Transportation as submitted at the time of bid with the public works contractor registration number	10 days after bid opening
Subcontractor List	Time of bid
Opt Out of Payment Adjustments for Price Index Fluctuations ^a	Time of bid
Certified DVBE Summary	No later than 4 p.m. on the 4th business day after bid opening
California Company Preference	Time of bid
Request for Small Business Preference or Non-Small Business Preference ^a	Time of bid
Certified Small Business Listing for the Non-Small Business Preference ^a	No later than 4 p.m. on the 2nd business day after bid opening

^aSubmit only if you choose the option or preference.

2-1.33D(3)(c) Contracts without a DVBE Goal

Reserved

2-1.33D(3)(d)–2-1.33D(3)(h) Reserved

2-1.33D(4)–2-1.33D(9) Reserved

02-21-14

2-1.34 BIDDER'S SECURITY

Submit one of the following forms of bidder's security equal to at least 10 percent of the bid:

1. Cash
2. Cashier's check
3. Certified check
4. Signed bidder's bond by an admitted surety insurer
5. For an electronic bid, electronic bidder's bond by an admitted surety insurer submitted using an electronic registry service approved by the Department.

Submit cash, cashier's check, certified check, or bidder's bond to the Department at the Bidders Exchange before the bid opening time.

Submit electronic bidder's bond with the electronic bid.

If using a bidder's bond, you may use the form in the *Bid* book. If you do not use the form in the *Bid* book, use a form containing the same information.

2-1.35–2-1.39 RESERVED

2-1.40 BID WITHDRAWAL

For a paper bid:

1. An authorized agent may withdraw a bid before the bid opening date and time by submitting a written bid withdrawal request at the location where the bid was submitted. Withdrawing a bid does not prevent you from submitting a new bid.
2. After the bid opening time, you cannot withdraw a bid.

For an electronic bid:

1. Bids are not filed with the Department until the date and time of bid opening.
2. A bidder may withdraw or revise a bid after it has been submitted to the electronic bidding service if this is done before the bid opening date and time.

2-1.41–2-1.42 RESERVED

2-1.43 BID OPENING

The Department publicly opens and reads bids at the time and place shown on the *Notice to Bidders*.

2-1.44–2-1.45 RESERVED

2-1.46 DEPARTMENT'S DECISION ON BID

The Department's decision on the bid amount is final.

The Department may reject:

1. All bids
2. A nonresponsive bid

2-1.47 BID RELIEF

The Department may grant bid relief under Pub Cont Code § 5100 et seq. Submit any request for bid relief to the Office Engineer. The Relief of Bid Request form is available at the Department's website.

2-1.48 RESERVED

2-1.49 SUBMITTAL FAILURE HISTORY

The Department considers a bidder's past failure to submit documents required after bid opening in determining a bidder's responsibility.

2-1.50 BID RIGGING

Section 2-1.50 applies to a federal-aid contract.

The U.S. Department of Transportation (DOT) provides a toll-free hotline to report bid rigging activities. Use the hotline to report bid rigging, bidder collusion, and other fraudulent activities. The hotline number is (800) 424-9071. The service is available 24 hours 7 days a week and is confidential and anonymous.. The hotline is part of the DOT's effort to identify and investigate highway construction contract fraud and abuse and is operated under the direction of the DOT Inspector General.

AA

3 CONTRACT AWARD AND EXECUTION

02-27-15

Replace section 3-1.02 with:

02-21-14

3-1.02 CONSIDERATION OF BIDS

3-1.02A General

For a lump sum based bid, the Department compares bids based on the total price.

For a unit price based bid, the Department compares bids based on the sum of the item totals.

For a cost plus time based bid, the Department compares bids based on the sum of the item totals and the total bid for time.

3-1.02B Tied Bids

The Department breaks a tied bid with a coin toss except:

- 1. If a small business bidder and a non-small business bidder request preferences and the reductions result in a tied bid, the Department awards the contract to the small business bidder.
- 2. If a DVBE small business bidder and a non-DVBE small business bidder request preferences and the reduction results in a tied bid, the Department awards the contract to the DVBE small business bidder.

Replace section 3-1.03 with:

02-27-15

3-1.03 CONTRACTOR REGISTRATION

No contractor or subcontractor may be awarded a contract for public work on a public works project (awarded on or after April 1, 2015) unless registered with the Department of Industrial Relations pursuant to Labor Code section 1725.5.

Add to the end of section 3-1.04:

10-19-12

You may request to extend the award period by faxing a request to (916) 227-6282 before 4:00 p.m. on the last day of the award period. If you do not make this request, after the specified award period:

- 1. Your bid becomes invalid
- 2. You are not eligible for the award of the contract

Replace the paragraph in section 3-1.11 with:

10-19-12

Complete and deliver to the Office Engineer a *Payee Data Record* when requested by the Department.

Replace the 1st paragraph of section 5-1.09C with:

10-19-12

For a contract with a total bid over \$10 million and 100 or more working days, training in partnering skills development is required.

10-19-12

Delete the 2nd paragraph of section 5-1.09C.

Replace "at least 2 representatives" in the 5th paragraph of section 5-1.09C with:

10-19-12

field supervisory personnel

Replace section 5-1.13B with:

01-23-15

5-1.13B Disadvantaged Business Enterprises

5-1.13B(1) General

Section 5-1.13B applies to a federal-aid contract.

Use each DBE as listed on the DBE Commitment form unless you receive authorization for a substitution. Ensure that all subcontracts and agreements with DBEs to supply labor or materials are performed under 49 CFR 26.

Maintain records, including:

1. Name and business address of each 1st-tier subcontractor
2. Name and business address of each DBE subcontractor, DBE vendor, and DBE trucking company, regardless of tier
3. Date of payment and total amount paid to each business

If you are a DBE contractor, include the date of work performed by your own forces and the corresponding value of the work.

Before the 15th day of each month for the previous month's work, submit:

1. Monthly DBE Trucking Verification form
2. Monthly DBE Payment form

If a DBE is decertified before completing its work, the DBE must notify you in writing of the decertification date. If a business becomes a certified DBE before completing its work, the business must notify you in writing of the certification date. Submit the notifications. Upon work completion, complete a Disadvantaged Business Enterprises (DBE) Certification Status Change form. Submit the form within 30 days of Contract acceptance.

Upon work completion, complete a Final Report – Utilization of Disadvantaged Business Enterprises (DBE), First-Tier Subcontractors form. Submit it within 30 days of Contract acceptance. The Department withholds \$10,000 until the form is submitted. The Department releases the withhold upon submission of the completed form.

5-1.13B(2) Performance of Disadvantaged Business Enterprises

Section 5-1.13(B)(2) applies if a DBE goal is shown on the *Notice to Bidders*.

DBEs must perform work or supply materials as listed on the DBE Commitment form.

Do not terminate or substitute a listed DBE for convenience and perform the work with your own forces or those of an affiliate, a non-DBE firm, or another DBE firm or obtain materials from other sources without authorization from the Department.

The Department authorizes a request to use other forces or sources of materials if it shows any of the following justifications:

1. Listed DBE fails or refuses to execute a written contract based on the plans and specifications for the project.
2. You stipulated that a bond is a condition of executing the subcontract and the listed DBE fails to meet your bond requirements.
3. Work requires a contractor license and the listed DBE does not have a valid license under the Contractors License Law.
4. Listed DBE fails or refuses to perform the work or furnish the listed materials.
5. Listed DBE's work is unsatisfactory and not in compliance with the Contract.
6. Listed DBE is ineligible to work on the project because of suspension or debarment.
7. Listed DBE becomes bankrupt or insolvent.
8. Listed DBE voluntarily withdraws with written notice from the Contract.
9. Listed DBE is ineligible to receive credit for the type of work required.
10. Listed DBE owner dies or becomes disabled resulting in the inability to perform the work on the Contract.
11. Department determines other documented good cause under 49 CFR 26.53.

Notify the original DBE of your intent to use other forces or material sources and provide the reasons. Provide the DBE with 5 days to respond to your notice and advise you and the Department of the reasons why the use of other forces or sources of materials should not occur. Your request to use other forces or material sources must include:

1. 1 or more of the reasons listed in the preceding paragraph
2. Notices from you to the DBE regarding the request
3. Notices from the DBE to you regarding the request

If the Department authorizes the termination or substitution of a listed DBE, make good faith efforts to find another DBE. The substitute DBE must (1) perform at least the same amount of work as the original DBE under the Contract to the extent needed to meet the DBE goal and (2) be certified as a DBE with the work code applicable to the type of work the DBE will perform on the Contract at the time of your request for substitution. Submit your good faith effort documentation within 7 days of your request for authorization of the substitution. The Department may authorize a 7-day extension of this submittal period at your request. Refer to 49 CFR 26 app A for guidance regarding evaluation of good faith efforts to meet the DBE goal.

Unless the Department authorizes a request to terminate or substitute a listed DBE, the Department does not pay for work unless it is performed or supplied by the DBE listed on the DBE Commitment form. You may be subject to other sanctions under 49 CFR 26.

Replace the paragraphs of section 5-1.13C with:

11-15-13

Section 5-1.13C applies to a non-federal-aid contract.

Use each DVBE as shown on the *Certified DVBE Summary* form unless you receive authorization from the Department for a substitution. The substitute must be another DVBE unless DVBEs are not available, in which case, you must substitute with a small business. Any authorization for a substitute is contingent upon the Department of General Services' approval of the substitute.

The requirement that DVBEs be certified by the bid opening date does not apply to DVBE substitutions after Contract award.

The Department authorizes substitutions for any of the reasons provided in 2 CA Code of Regs § 1896.73.

Include in your substitution request:

1. Copy of the written notice issued to the DVBE with proof of delivery
2. Copy of the DVBE's response to the notice
3. Name and certification number of the listed DVBE and the proposed substitute

Requests for substitutions of a listed DVBE with a small business must include documentation of the unavailability of DVBEs, including:

1. Contact with the small business/DVBE advocate from the Department and the Department of Veterans Affairs
2. Search results from the Department of General Services' website of available DVBEs
3. Communication with a DVBE community organization nearest the job site, if applicable
4. Documented communication with the DVBE and small businesses describing the work to be performed, the percentage of the total bid, the corresponding dollar amount, and the responses to the communication

The Department forwards your substitution request to the Department of General Services. The Department of General Services issues a notice of approval or denial. The Department provides you this notice.

If you fail to use a listed DVBE without an authorized substitution request, the Department issues a penalty of up to 10 percent of the dollar amount of the work of the listed DVBE.

Maintain records of subcontracts made with DVBEs. Include in the records:

1. Name and business address of each business
2. Total amount paid to each business

For the purpose of determining compliance with Pub Cont Code § 10115 et seq.:

1. Upon work completion, complete and submit *Final Report - Utilization of Disabled Veteran Business Enterprises (DVBE) State Funded Projects Only* form.
2. Upon reasonable notice and during normal business hours, permit access to its premises for the purposes of:
 - 2.1. Interviewing employees.

- 2.2. Inspecting and copying books, records, accounts and other material that may be relevant to a matter under investigation.

Replace "Reserved" in section 5-1.20C with:

10-19-12

If the Contract includes an agreement with a railroad company, the Department makes the provisions of the agreement available in the *Information Handout* in the document titled "Railroad Relations and Insurance Requirements." Comply with the requirements in the document.

Replace section 5-1.20E with:

05-30-14

5-1.20E Water Meter Charges

Section 5-1.20E applies if a bid item for water meter charges is shown on the Bid Item List. The charges are specified in a special provision for section 5-1.20E.

The local water authority will install the water meters.

The charges by the local water authority include:

1. Furnishing and installing each water meter
2. Connecting to the local water authority's main water line, including any required hot tap or tee
3. Furnishing and installing an extension pipe from the main water line to the water meter
4. Sterilizing the extension pipe

Make arrangements and pay the charges for the installation of the water meters.

If a charge is changed at the time of installation, the Department adjusts the lump sum price based on the difference between the specified charges and the changed charges.

Replace section 5-1.20F with:

05-30-14

5-1.20F Irrigation Water Service Charges

Reserved

Add between the 2nd and 3rd paragraphs of section 5-1.23A:

10-19-12

Submit action and informational submittals to the Engineer.

Add between the 5th and 6th paragraphs of section 5-1.23B(1):

07-19-13

For a revised submittal, allow the same number of days for review as for the original submittal.

6 CONTROL OF MATERIALS

07-19-13

Replace section 6-2.05C with:

04-19-13

6-2.05C Steel and Iron Materials

Steel and iron materials must be melted and manufactured in the United States except:

1. Foreign pig iron and processed, pelletized, and reduced iron ore may be used in the domestic production of the steel and iron materials
2. If the total combined cost of the materials does not exceed the greater of 0.1 percent of the total bid or \$2,500, materials produced outside the United States may be used if authorized

Furnish steel and iron materials to be incorporated into the work with certificates of compliance and certified mill test reports. Mill test reports must indicate where the steel and iron were melted and manufactured.

All melting and manufacturing processes for these materials, including an application of a coating, must occur in the United States. Coating includes all processes that protect or enhance the value of the material to which the coating is applied.

Replace "Precast concrete members specified section 11-2" in the table in section 6-3.05B with:

07-19-13

Precast concrete members specified as tier 1 or tier 2 in section 90-4.01D(1)

^^

7 LEGAL RELATIONS AND RESPONSIBILITY TO THE PUBLIC

02-27-15

Replace "§§ 1727 and 1770–1815" in the 1st sentence of the 1st paragraph of section 7-1.02K(1) with:

02-27-15

§ 1720 et seq.

Replace "\$50" in the 1st sentence in the 6th paragraph of section 7-1.02K(2) with:

07-19-13

\$200

Replace "\$25" in the 2nd sentence in the 13th paragraph of section 7-1.02K(3) with:

07-19-13

\$100

Delete "water or" in the 9th paragraph of section 7-1.03.

Replace "20 days" in the 14th paragraph of section 7-1.04 with:

09-16-11

25 days

Replace "90 days" in the 14th paragraph of section 7-1.04 with:

09-16-11

125 days

Add between the 18th and 19th paragraphs of section 7-1.04:

09-16-11

Temporary facilities that could be a hazard to public safety if improperly designed must comply with design requirements described in the Contract for those facilities or, if none are described, with standard design criteria or codes appropriate for the facility involved. Submit shop drawings and design calculations for the temporary facilities and show the standard design criteria or codes used. Shop drawings and supplemental calculations must be sealed and signed by an engineer who is registered as a civil engineer in the State.

Replace the 2nd paragraph of section 7-1.11A with:

07-27-12

A copy of form FHWA-1273 is included in section 7-1.11B. The training and promotion section of section II refers to training provisions as if they were included in the special provisions. The Department specifies the provisions in section 7-1.11D of the *Standard Specifications*. If a number of trainees or apprentices is required, the Department shows the number on the *Notice to Bidders*. Interpret each FHWA-1273 clause shown in the following table as having the same meaning as the corresponding Department clause:

FHWA-1273 Nondiscrimination Clauses

FHWA-1273 section	FHWA-1273 clause	Department clause
Training and Promotion	In the event a special provision for training is provided under this contract, this subparagraph will be superseded as indicated in the special provision.	If section 7-1.11D applies, section 7-1.11D supersedes this subparagraph.
Records and Reports	If on-the-job training is being required by special provision, the contractor will be required to collect and report training data.	If the Contract requires on-the-job training, collect and report training data.

Replace the form in section 7-1.11B with:

07-20-12

**REQUIRED CONTRACT PROVISIONS
FEDERAL-AID CONSTRUCTION CONTRACTS**

- I. General
- II. Nondiscrimination
- III. Nonsegregated Facilities
- IV. Davis-Bacon and Related Act Provisions
- V. Contract Work Hours and Safety Standards Act Provisions
- VI. Subletting or Assigning the Contract
- VII. Safety: Accident Prevention
- VIII. False Statements Concerning Highway Projects
- IX. Implementation of Clean Air Act and Federal Water Pollution Control Act
- X. Compliance with Governmentwide Suspension and Debarment Requirements
- XI. Certification Regarding Use of Contract Funds for Lobbying

ATTACHMENTS

A. Employment and Materials Preference for Appalachian Development Highway System or Appalachian Local Access Road Contracts (included in Appalachian contracts only)

I. GENERAL

1. Form FHWA-1273 must be physically incorporated in each construction contract funded under Title 23 (excluding emergency contracts solely intended for debris removal). The contractor (or subcontractor) must insert this form in each subcontract and further require its inclusion in all lower tier subcontracts (excluding purchase orders, rental agreements and other agreements for supplies or services).

The applicable requirements of Form FHWA-1273 are incorporated by reference for work done under any purchase order, rental agreement or agreement for other services. The prime contractor shall be responsible for compliance by any subcontractor, lower-tier subcontractor or service provider.

Form FHWA-1273 must be included in all Federal-aid design-build contracts, in all subcontracts and in lower tier subcontracts (excluding subcontracts for design services, purchase orders, rental agreements and other agreements for supplies or services). The design-builder shall be responsible for compliance by any subcontractor, lower-tier subcontractor or service provider.

Contracting agencies may reference Form FHWA-1273 in bid proposal or request for proposal documents, however, the Form FHWA-1273 must be physically incorporated (not referenced) in all contracts, subcontracts and lower-tier subcontracts (excluding purchase orders, rental agreements and other agreements for supplies or services related to a construction contract).

2. Subject to the applicability criteria noted in the following sections, these contract provisions shall apply to all work performed on the contract by the contractor's own organization and with the assistance of workers under the contractor's immediate superintendence and to all work performed on the contract by piecework, station work, or by subcontract.

3. A breach of any of the stipulations contained in these Required Contract Provisions may be sufficient grounds for withholding of progress payments, withholding of final payment, termination of the contract, suspension / debarment or any other action determined to be appropriate by the contracting agency and FHWA.

4. Selection of Labor: During the performance of this contract, the contractor shall not use convict labor for any purpose within the limits of a construction project on a Federal-aid highway unless it is labor performed by convicts who are on parole, supervised release, or probation. The term Federal-aid highway does not include roadways functionally classified as local roads or rural minor collectors.

II. NONDISCRIMINATION

The provisions of this section related to 23 CFR Part 230 are applicable to all Federal-aid construction contracts and to all related construction subcontracts of \$10,000 or more. The provisions of 23 CFR Part 230 are not applicable to material supply, engineering, or architectural service contracts.

In addition, the contractor and all subcontractors must comply with the following policies: Executive Order 11246, 41 CFR 60, 29 CFR 1625-1627, Title 23 USC Section 140, the Rehabilitation Act of 1973, as amended (29 USC 794), Title VI of the Civil Rights Act of 1964, as amended, and related regulations including 49 CFR Parts 21, 26 and 27; and 23 CFR Parts 200, 230, and 633.

The contractor and all subcontractors must comply with: the requirements of the Equal Opportunity Clause in 41 CFR 60-1.4(b) and, for all construction contracts exceeding \$10,000, the Standard Federal Equal Employment Opportunity Construction Contract Specifications in 41 CFR 60-4.3.

Note: The U.S. Department of Labor has exclusive authority to determine compliance with Executive Order 11246 and the policies of the Secretary of Labor including 41 CFR 60, and 29 CFR 1625-1627. The contracting agency and the FHWA have the authority and the responsibility to ensure compliance with Title 23 USC Section 140, the Rehabilitation Act of 1973, as amended (29 USC 794), and Title VI of the Civil Rights Act of 1964, as amended, and related regulations including 49 CFR Parts 21, 26 and 27; and 23 CFR Parts 200, 230, and 633.

The following provision is adopted from 23 CFR 230, Appendix A, with appropriate revisions to conform to the U.S. Department of Labor (US DOL) and FHWA requirements.

1. Equal Employment Opportunity: Equal employment opportunity (EEO) requirements not to discriminate and to take affirmative action to assure equal opportunity as set forth under laws, executive orders, rules, regulations (28 CFR 35, 29 CFR 1630, 29 CFR 1625-1627, 41 CFR 60 and 49 CFR 27) and orders of the Secretary of Labor as modified by the provisions prescribed herein, and imposed pursuant to 23 U.S.C. 140 shall constitute the EEO and specific affirmative action standards for the contractor's project activities under

this contract. The provisions of the Americans with Disabilities Act of 1990 (42 U.S.C. 12101 et seq.) set forth under 28 CFR 35 and 29 CFR 1630 are incorporated by reference in this contract. In the execution of this contract, the contractor agrees to comply with the following minimum specific requirement activities of EEO:

a. The contractor will work with the contracting agency and the Federal Government to ensure that it has made every good faith effort to provide equal opportunity with respect to all of its terms and conditions of employment and in their review of activities under the contract.

b. The contractor will accept as its operating policy the following statement:

"It is the policy of this Company to assure that applicants are employed, and that employees are treated during employment, without regard to their race, religion, sex, color, national origin, age or disability. Such action shall include: employment, upgrading, demotion, or transfer; recruitment or recruitment advertising; layoff or termination; rates of pay or other forms of compensation; and selection for training, including apprenticeship, pre-apprenticeship, and/or on-the-job training."

2. EEO Officer: The contractor will designate and make known to the contracting officers an EEO Officer who will have the responsibility for and must be capable of effectively administering and promoting an active EEO program and who must be assigned adequate authority and responsibility to do so.

3. Dissemination of Policy: All members of the contractor's staff who are authorized to hire, supervise, promote, and discharge employees, or who recommend such action, or who are substantially involved in such action, will be made fully cognizant of, and will implement, the contractor's EEO policy and contractual responsibilities to provide EEO in each grade and classification of employment. To ensure that the above agreement will be met, the following actions will be taken as a minimum:

a. Periodic meetings of supervisory and personnel office employees will be conducted before the start of work and then not less often than once every six months, at which time the contractor's EEO policy and its implementation will be reviewed and explained. The meetings will be conducted by the EEO Officer.

b. All new supervisory or personnel office employees will be given a thorough indoctrination by the EEO Officer, covering all major aspects of the contractor's EEO obligations within thirty days following their reporting for duty with the contractor.

c. All personnel who are engaged in direct recruitment for the project will be instructed by the EEO Officer in the contractor's procedures for locating and hiring minorities and women.

d. Notices and posters setting forth the contractor's EEO policy will be placed in areas readily accessible to employees, applicants for employment and potential employees.

e. The contractor's EEO policy and the procedures to implement such policy will be brought to the attention of employees by means of meetings, employee handbooks, or other appropriate means.

4. Recruitment: When advertising for employees, the contractor will include in all advertisements for employees the notation: "An Equal Opportunity Employer." All such advertisements will be placed in publications having a large circulation among minorities and women in the area from which the project work force would normally be derived.

a. The contractor will, unless precluded by a valid bargaining agreement, conduct systematic and direct recruitment through public and private employee referral sources likely to yield qualified minorities and women. To meet this requirement, the contractor will identify sources of potential minority group employees, and establish with such identified sources procedures whereby minority and women applicants may be referred to the contractor for employment consideration.

b. In the event the contractor has a valid bargaining agreement providing for exclusive hiring hall referrals, the contractor is expected to observe the provisions of that agreement to the extent that the system meets the contractor's compliance with EEO contract provisions. Where implementation of such an agreement has the effect of discriminating against minorities or women, or obligates the contractor to do the same, such implementation violates Federal nondiscrimination provisions.

c. The contractor will encourage its present employees to refer minorities and women as applicants for employment. Information and procedures with regard to referring such applicants will be discussed with employees.

5. Personnel Actions: Wages, working conditions, and employee benefits shall be established and administered, and personnel actions of every type, including hiring, upgrading, promotion, transfer, demotion, layoff, and termination, shall be taken without regard to race, color, religion, sex, national origin, age or disability. The following procedures shall be followed:

a. The contractor will conduct periodic inspections of project sites to insure that working conditions and employee facilities do not indicate discriminatory treatment of project site personnel.

b. The contractor will periodically evaluate the spread of wages paid within each classification to determine any evidence of discriminatory wage practices.

c. The contractor will periodically review selected personnel actions in depth to determine whether there is evidence of discrimination. Where evidence is found, the contractor will promptly take corrective action. If the review indicates that the discrimination may extend beyond the actions reviewed, such corrective action shall include all affected persons.

d. The contractor will promptly investigate all complaints of alleged discrimination made to the contractor in connection with its obligations under this contract, will attempt to resolve such complaints, and will take appropriate corrective action within a reasonable time. If the investigation indicates that the discrimination may affect persons other than the complainant, such corrective action shall include such other persons. Upon completion of each investigation, the contractor will inform every complainant of all of their avenues of appeal.

6. Training and Promotion:

a. The contractor will assist in locating, qualifying, and increasing the skills of minorities and women who are

applicants for employment or current employees. Such efforts should be aimed at developing full journey level status employees in the type of trade or job classification involved.

b. Consistent with the contractor's work force requirements and as permissible under Federal and State regulations, the contractor shall make full use of training programs, i.e., apprenticeship, and on-the-job training programs for the geographical area of contract performance. In the event a special provision for training is provided under this contract, this subparagraph will be superseded as indicated in the special provision. The contracting agency may reserve training positions for persons who receive welfare assistance in accordance with 23 U.S.C. 140(a).

c. The contractor will advise employees and applicants for employment of available training programs and entrance requirements for each.

d. The contractor will periodically review the training and promotion potential of employees who are minorities and women and will encourage eligible employees to apply for such training and promotion.

7. Unions: If the contractor relies in whole or in part upon unions as a source of employees, the contractor will use good faith efforts to obtain the cooperation of such unions to increase opportunities for minorities and women. Actions by the contractor, either directly or through a contractor's association acting as agent, will include the procedures set forth below:

a. The contractor will use good faith efforts to develop, in cooperation with the unions, joint training programs aimed toward qualifying more minorities and women for membership in the unions and increasing the skills of minorities and women so that they may qualify for higher paying employment.

b. The contractor will use good faith efforts to incorporate an EEO clause into each union agreement to the end that such union will be contractually bound to refer applicants without regard to their race, color, religion, sex, national origin, age or disability.

c. The contractor is to obtain information as to the referral practices and policies of the labor union except that to the extent such information is within the exclusive possession of the labor union and such labor union refuses to furnish such information to the contractor, the contractor shall so certify to the contracting agency and shall set forth what efforts have been made to obtain such information.

d. In the event the union is unable to provide the contractor with a reasonable flow of referrals within the time limit set forth in the collective bargaining agreement, the contractor will, through independent recruitment efforts, fill the employment vacancies without regard to race, color, religion, sex, national origin, age or disability; making full efforts to obtain qualified and/or qualified minorities and women. The failure of a union to provide sufficient referrals (even though it is obligated to provide exclusive referrals under the terms of a collective bargaining agreement) does not relieve the contractor from the requirements of this paragraph. In the event the union referral practice prevents the contractor from meeting the obligations pursuant to Executive Order 11246, as amended, and these special provisions, such contractor shall immediately notify the contracting agency.

8. Reasonable Accommodation for Applicants / Employees with Disabilities: The contractor must be familiar

with the requirements for and comply with the Americans with Disabilities Act and all rules and regulations established there under. Employers must provide reasonable accommodation in all employment activities unless to do so would cause an undue hardship.

9. Selection of Subcontractors, Procurement of Materials and Leasing of Equipment: The contractor shall not discriminate on the grounds of race, color, religion, sex, national origin, age or disability in the selection and retention of subcontractors, including procurement of materials and leases of equipment. The contractor shall take all necessary and reasonable steps to ensure nondiscrimination in the administration of this contract.

a. The contractor shall notify all potential subcontractors and suppliers and lessors of their EEO obligations under this contract.

b. The contractor will use good faith efforts to ensure subcontractor compliance with their EEO obligations.

10. Assurance Required by 49 CFR 26.13(b):

a. The requirements of 49 CFR Part 26 and the State DOT's U.S. DOT-approved DBE program are incorporated by reference.

b. The contractor or subcontractor shall not discriminate on the basis of race, color, national origin, or sex in the performance of this contract. The contractor shall carry out applicable requirements of 49 CFR Part 26 in the award and administration of DOT-assisted contracts. Failure by the contractor to carry out these requirements is a material breach of this contract, which may result in the termination of this contract or such other remedy as the contracting agency deems appropriate.

11. Records and Reports: The contractor shall keep such records as necessary to document compliance with the EEO requirements. Such records shall be retained for a period of three years following the date of the final payment to the contractor for all contract work and shall be available at reasonable times and places for inspection by authorized representatives of the contracting agency and the FHWA.

a. The records kept by the contractor shall document the following:

(1) The number and work hours of minority and non-minority group members and women employed in each work classification on the project;

(2) The progress and efforts being made in cooperation with unions, when applicable, to increase employment opportunities for minorities and women; and

(3) The progress and efforts being made in locating, hiring, training, qualifying, and upgrading minorities and women;

b. The contractors and subcontractors will submit an annual report to the contracting agency each July for the duration of the project, indicating the number of minority, women, and non-minority group employees currently engaged in each work classification required by the contract work. This information is to be reported on [Form FHWA-1391](#). The staffing data should represent the project work force on board in all or any part of the last payroll period preceding the end of July. If on-the-job training is being required by special provision, the contractor

will be required to collect and report training data. The employment data should reflect the work force on board during all or any part of the last payroll period preceding the end of July.

III. NONSEGREGATED FACILITIES

This provision is applicable to all Federal-aid construction contracts and to all related construction subcontracts of \$10,000 or more.

The contractor must ensure that facilities provided for employees are provided in such a manner that segregation on the basis of race, color, religion, sex, or national origin cannot result. The contractor may neither require such segregated use by written or oral policies nor tolerate such use by employee custom. The contractor's obligation extends further to ensure that its employees are not assigned to perform their services at any location, under the contractor's control, where the facilities are segregated. The term "facilities" includes waiting rooms, work areas, restaurants and other eating areas, time clocks, restrooms, washrooms, locker rooms, and other storage or dressing areas, parking lots, drinking fountains, recreation or entertainment areas, transportation, and housing provided for employees. The contractor shall provide separate or single-user restrooms and necessary dressing or sleeping areas to assure privacy between sexes.

IV. DAVIS-BACON AND RELATED ACT PROVISIONS

This section is applicable to all Federal-aid construction projects exceeding \$2,000 and to all related subcontracts and lower-tier subcontracts (regardless of subcontract size). The requirements apply to all projects located within the right-of-way of a roadway that is functionally classified as Federal-aid highway. This excludes roadways functionally classified as local roads or rural minor collectors, which are exempt. Contracting agencies may elect to apply these requirements to other projects.

The following provisions are from the U.S. Department of Labor regulations in 29 CFR 5.5 "Contract provisions and related matters" with minor revisions to conform to the FHWA-1273 format and FHWA program requirements.

1. Minimum wages

a. All laborers and mechanics employed or working upon the site of the work, will be paid unconditionally and not less often than once a week, and without subsequent deduction or rebate on any account (except such payroll deductions as are permitted by regulations issued by the Secretary of Labor under the Copeland Act (29 CFR part 3)), the full amount of wages and bona fide fringe benefits (or cash equivalents thereof) due at time of payment computed at rates not less than those contained in the wage determination of the Secretary of Labor which is attached hereto and made a part hereof, regardless of any contractual relationship which may be alleged to exist between the contractor and such laborers and mechanics.

Contributions made or costs reasonably anticipated for bona fide fringe benefits under section 1(b)(2) of the Davis-Bacon Act on behalf of laborers or mechanics are considered wages paid to such laborers or mechanics, subject to the provisions

of paragraph 1.d. of this section; also, regular contributions made or costs incurred for more than a weekly period (but not less often than quarterly) under plans, funds, or programs which cover the particular weekly period, are deemed to be constructively made or incurred during such weekly period. Such laborers and mechanics shall be paid the appropriate wage rate and fringe benefits on the wage determination for the classification of work actually performed, without regard to skill, except as provided in 29 CFR 5.5(a)(4). Laborers or mechanics performing work in more than one classification may be compensated at the rate specified for each classification for the time actually worked therein: Provided, That the employer's payroll records accurately set forth the time spent in each classification in which work is performed. The wage determination (including any additional classification and wage rates conformed under paragraph 1.b. of this section) and the Davis-Bacon poster (WH-1321) shall be posted at all times by the contractor and its subcontractors at the site of the work in a prominent and accessible place where it can be easily seen by the workers.

b.(1) The contracting officer shall require that any class of laborers or mechanics, including helpers, which is not listed in the wage determination and which is to be employed under the contract shall be classified in conformance with the wage determination. The contracting officer shall approve an additional classification and wage rate and fringe benefits therefore only when the following criteria have been met:

(i) The work to be performed by the classification requested is not performed by a classification in the wage determination; and

(ii) The classification is utilized in the area by the construction industry; and

(iii) The proposed wage rate, including any bona fide fringe benefits, bears a reasonable relationship to the wage rates contained in the wage determination.

(2) If the contractor and the laborers and mechanics to be employed in the classification (if known), or their representatives, and the contracting officer agree on the classification and wage rate (including the amount designated for fringe benefits where appropriate), a report of the action taken shall be sent by the contracting officer to the Administrator of the Wage and Hour Division, Employment Standards Administration, U.S. Department of Labor, Washington, DC 20210. The Administrator, or an authorized representative, will approve, modify, or disapprove every additional classification action within 30 days of receipt and so advise the contracting officer or will notify the contracting officer within the 30-day period that additional time is necessary.

(3) In the event the contractor, the laborers or mechanics to be employed in the classification or their representatives, and the contracting officer do not agree on the proposed classification and wage rate (including the amount designated for fringe benefits, where appropriate), the contracting officer shall refer the questions, including the views of all interested parties and the recommendation of the contracting officer, to the Wage and Hour Administrator for determination. The Wage and Hour Administrator, or an authorized representative, will issue a determination within 30 days of receipt and so advise the contracting officer or

will notify the contracting officer within the 30-day period that additional time is necessary.

(4) The wage rate (including fringe benefits where appropriate) determined pursuant to paragraphs 1.b.(2) or 1.b.(3) of this section, shall be paid to all workers performing work in the classification under this contract from the first day on which work is performed in the classification.

c. Whenever the minimum wage rate prescribed in the contract for a class of laborers or mechanics includes a fringe benefit which is not expressed as an hourly rate, the contractor shall either pay the benefit as stated in the wage determination or shall pay another bona fide fringe benefit or an hourly cash equivalent thereof.

d. If the contractor does not make payments to a trustee or other third person, the contractor may consider as part of the wages of any laborer or mechanic the amount of any costs reasonably anticipated in providing bona fide fringe benefits under a plan or program. Provided, That the Secretary of Labor has found, upon the written request of the contractor, that the applicable standards of the Davis-Bacon Act have been met. The Secretary of Labor may require the contractor to set aside in a separate account assets for the meeting of obligations under the plan or program.

2. Withholding

The contracting agency shall upon its own action or upon written request of an authorized representative of the Department of Labor, withhold or cause to be withheld from the contractor under this contract, or any other Federal contract with the same prime contractor, or any other federally-assisted contract subject to Davis-Bacon prevailing wage requirements, which is held by the same prime contractor, so much of the accrued payments or advances as may be considered necessary to pay laborers and mechanics, including apprentices, trainees, and helpers, employed by the contractor or any subcontractor the full amount of wages required by the contract. In the event of failure to pay any laborer or mechanic, including any apprentice, trainee, or helper, employed or working on the site of the work, all or part of the wages required by the contract, the contracting agency may, after written notice to the contractor, take such action as may be necessary to cause the suspension of any further payment, advance, or guarantee of funds until such violations have ceased.

3. Payrolls and basic records

a. Payrolls and basic records relating thereto shall be maintained by the contractor during the course of the work and preserved for a period of three years thereafter for all laborers and mechanics working at the site of the work. Such records shall contain the name, address, and social security number of each such worker, his or her correct classification, hourly rates of wages paid (including rates of contributions or costs anticipated for bona fide fringe benefits or cash equivalents thereof of the types described in section 1(b)(2)(B) of the Davis-Bacon Act), daily and weekly number of hours worked, deductions made and actual wages paid. Whenever the Secretary of Labor has found under 29 CFR 5.5(a)(1)(iv) that the wages of any laborer or mechanic include the amount of any costs reasonably anticipated in providing benefits under a plan or program described in section 1(b)(2)(B) of the Davis-

Bacon Act, the contractor shall maintain records which show that the commitment to provide such benefits is enforceable, that the plan or program is financially responsible, and that the plan or program has been communicated in writing to the laborers or mechanics affected, and records which show the costs anticipated or the actual cost incurred in providing such benefits. Contractors employing apprentices or trainees under approved programs shall maintain written evidence of the registration of apprenticeship programs and certification of trainee programs, the registration of the apprentices and trainees, and the ratios and wage rates prescribed in the applicable programs.

b.(1) The contractor shall submit weekly for each week in which any contract work is performed a copy of all payrolls to the contracting agency. The payrolls submitted shall set out accurately and completely all of the information required to be maintained under 29 CFR 5.5(a)(3)(i), except that full social security numbers and home addresses shall not be included on weekly transmittals. Instead the payrolls shall only need to include an individually identifying number for each employee (e.g., the last four digits of the employee's social security number). The required weekly payroll information may be submitted in any form desired. Optional Form WH-347 is available for this purpose from the Wage and Hour Division Web site at <http://www.dol.gov/esa/whd/forms/wh347instr.htm> or its successor site. The prime contractor is responsible for the submission of copies of payrolls by all subcontractors. Contractors and subcontractors shall maintain the full social security number and current address of each covered worker, and shall provide them upon request to the contracting agency for transmission to the State DOT, the FHWA or the Wage and Hour Division of the Department of Labor for purposes of an investigation or audit of compliance with prevailing wage requirements. It is not a violation of this section for a prime contractor to require a subcontractor to provide addresses and social security numbers to the prime contractor for its own records, without weekly submission to the contracting agency..

(2) Each payroll submitted shall be accompanied by a "Statement of Compliance," signed by the contractor or subcontractor or his or her agent who pays or supervises the payment of the persons employed under the contract and shall certify the following:

(i) That the payroll for the payroll period contains the information required to be provided under §5.5 (a)(3)(ii) of Regulations, 29 CFR part 5, the appropriate information is being maintained under §5.5 (a)(3)(i) of Regulations, 29 CFR part 5, and that such information is correct and complete;

(ii) That each laborer or mechanic (including each helper, apprentice, and trainee) employed on the contract during the payroll period has been paid the full weekly wages earned, without rebate, either directly or indirectly, and that no deductions have been made either directly or indirectly from the full wages earned, other than permissible deductions as set forth in Regulations, 29 CFR part 3;

(iii) That each laborer or mechanic has been paid not less than the applicable wage rates and fringe benefits or cash equivalents for the classification of work performed, as specified in the applicable wage determination incorporated into the contract.

(3) The weekly submission of a properly executed certification set forth on the reverse side of Optional Form WH-347 shall satisfy the requirement for submission of the "Statement of Compliance" required by paragraph 3.b.(2) of this section.

(4) The falsification of any of the above certifications may subject the contractor or subcontractor to civil or criminal prosecution under section 1001 of title 18 and section 231 of title 31 of the United States Code.

c. The contractor or subcontractor shall make the records required under paragraph 3.a. of this section available for inspection, copying, or transcription by authorized representatives of the contracting agency, the State DOT, the FHWA, or the Department of Labor, and shall permit such representatives to interview employees during working hours on the job. If the contractor or subcontractor fails to submit the required records or to make them available, the FHWA may, after written notice to the contractor, the contracting agency or the State DOT, take such action as may be necessary to cause the suspension of any further payment, advance, or guarantee of funds. Furthermore, failure to submit the required records upon request or to make such records available may be grounds for debarment action pursuant to 29 CFR 5.12.

4. Apprentices and trainees

a. Apprentices (programs of the USDOL).

Apprentices will be permitted to work at less than the predetermined rate for the work they performed when they are employed pursuant to and individually registered in a bona fide apprenticeship program registered with the U.S. Department of Labor, Employment and Training Administration, Office of Apprenticeship Training, Employer and Labor Services, or with a State Apprenticeship Agency recognized by the Office, or if a person is employed in his or her first 90 days of probationary employment as an apprentice in such an apprenticeship program, who is not individually registered in the program, but who has been certified by the Office of Apprenticeship Training, Employer and Labor Services or a State Apprenticeship Agency (where appropriate) to be eligible for probationary employment as an apprentice.

The allowable ratio of apprentices to journeymen on the job site in any craft classification shall not be greater than the ratio permitted to the contractor as to the entire work force under the registered program. Any worker listed on a payroll at an apprentice wage rate, who is not registered or otherwise employed as stated above, shall be paid not less than the applicable wage rate on the wage determination for the classification of work actually performed. In addition, any apprentice performing work on the job site in excess of the ratio permitted under the registered program shall be paid not less than the applicable wage rate on the wage determination for the work actually performed. Where a contractor is performing construction on a project in a locality other than that in which its program is registered, the ratios and wage rates (expressed in percentages of the journeyman's hourly rate) specified in the contractor's or subcontractor's registered program shall be observed.

Every apprentice must be paid at not less than the rate specified in the registered program for the apprentice's level of progress, expressed as a percentage of the journeymen hourly

rate specified in the applicable wage determination. Apprentices shall be paid fringe benefits in accordance with the provisions of the apprenticeship program. If the apprenticeship program does not specify fringe benefits, apprentices must be paid the full amount of fringe benefits listed on the wage determination for the applicable classification. If the Administrator determines that a different practice prevails for the applicable apprentice classification, fringes shall be paid in accordance with that determination.

In the event the Office of Apprenticeship Training, Employer and Labor Services, or a State Apprenticeship Agency recognized by the Office, withdraws approval of an apprenticeship program, the contractor will no longer be permitted to utilize apprentices at less than the applicable predetermined rate for the work performed until an acceptable program is approved.

b. Trainees (programs of the USDOL).

Except as provided in 29 CFR 5.16, trainees will not be permitted to work at less than the predetermined rate for the work performed unless they are employed pursuant to and individually registered in a program which has received prior approval, evidenced by formal certification by the U.S. Department of Labor, Employment and Training Administration.

The ratio of trainees to journeymen on the job site shall not be greater than permitted under the plan approved by the Employment and Training Administration.

Every trainee must be paid at not less than the rate specified in the approved program for the trainee's level of progress, expressed as a percentage of the journeyman hourly rate specified in the applicable wage determination. Trainees shall be paid fringe benefits in accordance with the provisions of the trainee program. If the trainee program does not mention fringe benefits, trainees shall be paid the full amount of fringe benefits listed on the wage determination unless the Administrator of the Wage and Hour Division determines that there is an apprenticeship program associated with the corresponding journeyman wage rate on the wage determination which provides for less than full fringe benefits for apprentices. Any employee listed on the payroll at a trainee rate who is not registered and participating in a training plan approved by the Employment and Training Administration shall be paid not less than the applicable wage rate on the wage determination for the classification of work actually performed. In addition, any trainee performing work on the job site in excess of the ratio permitted under the registered program shall be paid not less than the applicable wage rate on the wage determination for the work actually performed.

In the event the Employment and Training Administration withdraws approval of a training program, the contractor will no longer be permitted to utilize trainees at less than the applicable predetermined rate for the work performed until an acceptable program is approved.

c. Equal employment opportunity. The utilization of apprentices, trainees and journeymen under this part shall be in conformity with the equal employment opportunity requirements of Executive Order 11246, as amended, and 29 CFR part 30.

d. Apprentices and Trainees (programs of the U.S. DOT).

Apprentices and trainees working under apprenticeship and skill training programs which have been certified by the Secretary of Transportation as promoting EEO in connection with Federal-aid highway construction programs are not subject to the requirements of paragraph 4 of this Section IV. The straight time hourly wage rates for apprentices and trainees under such programs will be established by the particular programs. The ratio of apprentices and trainees to journeymen shall not be greater than permitted by the terms of the particular program.

5. Compliance with Copeland Act requirements. The contractor shall comply with the requirements of 29 CFR part 3, which are incorporated by reference in this contract.

6. Subcontracts. The contractor or subcontractor shall insert Form FHWA-1273 in any subcontracts and also require the subcontractors to include Form FHWA-1273 in any lower tier subcontracts. The prime contractor shall be responsible for the compliance by any subcontractor or lower tier subcontractor with all the contract clauses in 29 CFR 5.5.

7. Contract termination; debarment. A breach of the contract clauses in 29 CFR 5.5 may be grounds for termination of the contract, and for debarment as a contractor and a subcontractor as provided in 29 CFR 5.12.

8. Compliance with Davis-Bacon and Related Act requirements. All rulings and interpretations of the Davis-Bacon and Related Acts contained in 29 CFR parts 1, 3, and 5 are herein incorporated by reference in this contract.

9. Disputes concerning labor standards. Disputes arising out of the labor standards provisions of this contract shall not be subject to the general disputes clause of this contract. Such disputes shall be resolved in accordance with the procedures of the Department of Labor set forth in 29 CFR parts 5, 6, and 7. Disputes within the meaning of this clause include disputes between the contractor (or any of its subcontractors) and the contracting agency, the U.S. Department of Labor, or the employees or their representatives.

10. Certification of eligibility.

a. By entering into this contract, the contractor certifies that neither it (nor he or she) nor any person or firm who has an interest in the contractor's firm is a person or firm ineligible to be awarded Government contracts by virtue of section 3(a) of the Davis-Bacon Act or 29 CFR 5.12(a)(1).

b. No part of this contract shall be subcontracted to any person or firm ineligible for award of a Government contract by virtue of section 3(a) of the Davis-Bacon Act or 29 CFR 5.12(a)(1).

c. The penalty for making false statements is prescribed in the U.S. Criminal Code, 18 U.S.C. 1001.

V. CONTRACT WORK HOURS AND SAFETY STANDARDS ACT

The following clauses apply to any Federal-aid construction contract in an amount in excess of \$100,000 and subject to the overtime provisions of the Contract Work Hours and Safety Standards Act. These clauses shall be inserted in addition to the clauses required by 29 CFR 5.5(a) or 29 CFR 4.6. As used in this paragraph, the terms laborers and mechanics include watchmen and guards.

1. Overtime requirements. No contractor or subcontractor contracting for any part of the contract work which may require or involve the employment of laborers or mechanics shall require or permit any such laborer or mechanic in any workweek in which he or she is employed on such work to work in excess of forty hours in such workweek unless such laborer or mechanic receives compensation at a rate not less than one and one-half times the basic rate of pay for all hours worked in excess of forty hours in such workweek.

2. Violation; liability for unpaid wages; liquidated damages. In the event of any violation of the clause set forth in paragraph (1.) of this section, the contractor and any subcontractor responsible therefor shall be liable for the unpaid wages. In addition, such contractor and subcontractor shall be liable to the United States (in the case of work done under contract for the District of Columbia or a territory, to such District or to such territory), for liquidated damages. Such liquidated damages shall be computed with respect to each individual laborer or mechanic, including watchmen and guards, employed in violation of the clause set forth in paragraph (1.) of this section, in the sum of \$10 for each calendar day on which such individual was required or permitted to work in excess of the standard workweek of forty hours without payment of the overtime wages required by the clause set forth in paragraph (1.) of this section.

3. Withholding for unpaid wages and liquidated damages. The FHWA or the contracting agency shall upon its own action or upon written request of an authorized representative of the Department of Labor withhold or cause to be withheld, from any moneys payable on account of work performed by the contractor or subcontractor under any such contract or any other Federal contract with the same prime contractor, or any other federally-assisted contract subject to the Contract Work Hours and Safety Standards Act, which is held by the same prime contractor, such sums as may be determined to be necessary to satisfy any liabilities of such contractor or subcontractor for unpaid wages and liquidated damages as provided in the clause set forth in paragraph (2.) of this section.

4. Subcontracts. The contractor or subcontractor shall insert in any subcontracts the clauses set forth in paragraph (1.) through (4.) of this section and also a clause requiring the subcontractors to include these clauses in any lower tier subcontracts. The prime contractor shall be responsible for compliance by any subcontractor or lower tier subcontractor with the clauses set forth in paragraphs (1.) through (4.) of this section.

VI. SUBLETTING OR ASSIGNING THE CONTRACT

This provision is applicable to all Federal-aid construction contracts on the National Highway System.

1. The contractor shall perform with its own organization contract work amounting to not less than 30 percent (or a greater percentage if specified elsewhere in the contract) of the total original contract price, excluding any specialty items designated by the contracting agency. Specialty items may be performed by subcontract and the amount of any such specialty items performed may be deducted from the total original contract price before computing the amount of work required to be performed by the contractor's own organization (23 CFR 635.116).

a. The term "perform work with its own organization" refers to workers employed or leased by the prime contractor, and equipment owned or rented by the prime contractor, with or without operators. Such term does not include employees or equipment of a subcontractor or lower tier subcontractor, agents of the prime contractor, or any other assignees. The term may include payments for the costs of hiring leased employees from an employee leasing firm meeting all relevant Federal and State regulatory requirements. Leased employees may only be included in this term if the prime contractor meets all of the following conditions:

(1) the prime contractor maintains control over the supervision of the day-to-day activities of the leased employees;

(2) the prime contractor remains responsible for the quality of the work of the leased employees;

(3) the prime contractor retains all power to accept or exclude individual employees from work on the project; and

(4) the prime contractor remains ultimately responsible for the payment of predetermined minimum wages, the submission of payrolls, statements of compliance and all other Federal regulatory requirements.

b. "Specialty Items" shall be construed to be limited to work that requires highly specialized knowledge, abilities, or equipment not ordinarily available in the type of contracting organizations qualified and expected to bid or propose on the contract as a whole and in general are to be limited to minor components of the overall contract.

2. The contract amount upon which the requirements set forth in paragraph (1) of Section VI is computed includes the cost of material and manufactured products which are to be purchased or produced by the contractor under the contract provisions.

3. The contractor shall furnish (a) a competent superintendent or supervisor who is employed by the firm, has full authority to direct performance of the work in accordance with the contract requirements, and is in charge of all construction operations (regardless of who performs the work) and (b) such other of its own organizational resources (supervision, management, and engineering services) as the contracting officer determines is necessary to assure the performance of the contract.

4. No portion of the contract shall be sublet, assigned or otherwise disposed of except with the written consent of the contracting officer, or authorized representative, and such consent when given shall not be construed to relieve the contractor of any responsibility for the fulfillment of the contract. Written consent will be given only after the contracting agency has assured that each subcontract is

evidenced in writing and that it contains all pertinent provisions and requirements of the prime contract.

5. The 30% self-performance requirement of paragraph (1) is not applicable to design-build contracts; however, contracting agencies may establish their own self-performance requirements.

VII. SAFETY: ACCIDENT PREVENTION

This provision is applicable to all Federal-aid construction contracts and to all related subcontracts.

1. In the performance of this contract the contractor shall comply with all applicable Federal, State, and local laws governing safety, health, and sanitation (23 CFR 635). The contractor shall provide all safeguards, safety devices and protective equipment and take any other needed actions as it determines, or as the contracting officer may determine, to be reasonably necessary to protect the life and health of employees on the job and the safety of the public and to protect property in connection with the performance of the work covered by the contract.

2. It is a condition of this contract, and shall be made a condition of each subcontract, which the contractor enters into pursuant to this contract, that the contractor and any subcontractor shall not permit any employee, in performance of the contract, to work in surroundings or under conditions which are unsanitary, hazardous or dangerous to his/her health or safety, as determined under construction safety and health standards (29 CFR 1926) promulgated by the Secretary of Labor, in accordance with Section 107 of the Contract Work Hours and Safety Standards Act (40 U.S.C. 3704).

3. Pursuant to 29 CFR 1926.3, it is a condition of this contract that the Secretary of Labor or authorized representative thereof, shall have right of entry to any site of contract performance to inspect or investigate the matter of compliance with the construction safety and health standards and to carry out the duties of the Secretary under Section 107 of the Contract Work Hours and Safety Standards Act (40 U.S.C.3704).

VIII. FALSE STATEMENTS CONCERNING HIGHWAY PROJECTS

This provision is applicable to all Federal-aid construction contracts and to all related subcontracts.

In order to assure high quality and durable construction in conformity with approved plans and specifications and a high degree of reliability on statements and representations made by engineers, contractors, suppliers, and workers on Federal-aid highway projects, it is essential that all persons concerned with the project perform their functions as carefully, thoroughly, and honestly as possible. Willful falsification, distortion, or misrepresentation with respect to any facts related to the project is a violation of Federal law. To prevent any misunderstanding regarding the seriousness of these and similar acts, Form FHWA-1022 shall be posted on each Federal-aid highway project (23 CFR 635) in one or more places where it is readily available to all persons concerned with the project:

18 U.S.C. 1020 reads as follows:

"Whoever, being an officer, agent, or employee of the United States, or of any State or Territory, or whoever, whether a person, association, firm, or corporation, knowingly makes any false statement, false representation, or false report as to the character, quality, quantity, or cost of the material used or to be used, or the quantity or quality of the work performed or to be performed, or the cost thereof in connection with the submission of plans, maps, specifications, contracts, or costs of construction on any highway or related project submitted for approval to the Secretary of Transportation; or

Whoever knowingly makes any false statement, false representation, false report or false claim with respect to the character, quality, quantity, or cost of any work performed or to be performed, or materials furnished or to be furnished, in connection with the construction of any highway or related project approved by the Secretary of Transportation; or

Whoever knowingly makes any false statement or false representation as to material fact in any statement, certificate, or report submitted pursuant to provisions of the Federal-aid Roads Act approved July 1, 1916, (39 Stat. 355), as amended and supplemented;

Shall be fined under this title or imprisoned not more than 5 years or both."

IX. IMPLEMENTATION OF CLEAN AIR ACT AND FEDERAL WATER POLLUTION CONTROL ACT

This provision is applicable to all Federal-aid construction contracts and to all related subcontracts.

By submission of this bid/proposal or the execution of this contract, or subcontract, as appropriate, the bidder, proposer, Federal-aid construction contractor, or subcontractor, as appropriate, will be deemed to have stipulated as follows:

1. That any person who is or will be utilized in the performance of this contract is not prohibited from receiving an award due to a violation of Section 508 of the Clean Water Act or Section 306 of the Clean Air Act.
2. That the contractor agrees to include or cause to be included the requirements of paragraph (1) of this Section X in every subcontract, and further agrees to take such action as the contracting agency may direct as a means of enforcing such requirements.

X. CERTIFICATION REGARDING DEBARMENT, SUSPENSION, INELIGIBILITY AND VOLUNTARY EXCLUSION

This provision is applicable to all Federal-aid construction contracts, design-build contracts, subcontracts, lower-tier subcontracts, purchase orders, lease agreements, consultant contracts or any other covered transaction requiring FHWA approval or that is estimated to cost \$25,000 or more – as defined in 2 CFR Parts 180 and 1200.

1. Instructions for Certification – First Tier Participants:

- a. By signing and submitting this proposal, the prospective first tier participant is providing the certification set out below.
- b. The inability of a person to provide the certification set out below will not necessarily result in denial of participation in this

covered transaction. The prospective first tier participant shall submit an explanation of why it cannot provide the certification set out below. The certification or explanation will be considered in connection with the department or agency's determination whether to enter into this transaction. However, failure of the prospective first tier participant to furnish a certification or an explanation shall disqualify such a person from participation in this transaction.

c. The certification in this clause is a material representation of fact upon which reliance was placed when the contracting agency determined to enter into this transaction. If it is later determined that the prospective participant knowingly rendered an erroneous certification, in addition to other remedies available to the Federal Government, the contracting agency may terminate this transaction for cause of default.

d. The prospective first tier participant shall provide immediate written notice to the contracting agency to whom this proposal is submitted if any time the prospective first tier participant learns that its certification was erroneous when submitted or has become erroneous by reason of changed circumstances.

e. The terms "covered transaction," "debarred," "suspended," "ineligible," "participant," "person," "principal," and "voluntarily excluded," as used in this clause, are defined in 2 CFR Parts 180 and 1200. "First Tier Covered Transactions" refers to any covered transaction between a grantee or subgrantee of Federal funds and a participant (such as the prime or general contract). "Lower Tier Covered Transactions" refers to any covered transaction under a First Tier Covered Transaction (such as subcontracts). "First Tier Participant" refers to the participant who has entered into a covered transaction with a grantee or subgrantee of Federal funds (such as the prime or general contractor). "Lower Tier Participant" refers any participant who has entered into a covered transaction with a First Tier Participant or other Lower Tier Participants (such as subcontractors and suppliers).

f. The prospective first tier participant agrees by submitting this proposal that, should the proposed covered transaction be entered into, it shall not knowingly enter into any lower tier covered transaction with a person who is debarred, suspended, declared ineligible, or voluntarily excluded from participation in this covered transaction, unless authorized by the department or agency entering into this transaction.

g. The prospective first tier participant further agrees by submitting this proposal that it will include the clause titled "Certification Regarding Debarment, Suspension, Ineligibility and Voluntary Exclusion-Lower Tier Covered Transactions," provided by the department or contracting agency, entering into this covered transaction, without modification, in all lower tier covered transactions and in all solicitations for lower tier covered transactions exceeding the \$25,000 threshold.

h. A participant in a covered transaction may rely upon a certification of a prospective participant in a lower tier covered transaction that is not debarred, suspended, ineligible, or voluntarily excluded from the covered transaction, unless it knows that the certification is erroneous. A participant is responsible for ensuring that its principals are not suspended, debarred, or otherwise ineligible to participate in covered transactions. To verify the eligibility of its principals, as well as the eligibility of any lower tier prospective participants, each participant may, but is not required to, check the Excluded Parties List System website (<https://www.epls.gov/>), which is compiled by the General Services Administration.

i. Nothing contained in the foregoing shall be construed to require the establishment of a system of records in order to render in good faith the certification required by this clause. The knowledge and information of the prospective participant is not required to exceed that which is normally possessed by a prudent person in the ordinary course of business dealings.

j. Except for transactions authorized under paragraph (f) of these instructions, if a participant in a covered transaction knowingly enters into a lower tier covered transaction with a person who is suspended, debarred, ineligible, or voluntarily excluded from participation in this transaction, in addition to other remedies available to the Federal Government, the department or agency may terminate this transaction for cause or default.

2. Certification Regarding Debarment, Suspension, Ineligibility and Voluntary Exclusion – First Tier Participants:

a. The prospective first tier participant certifies to the best of its knowledge and belief, that it and its principals:

(1) Are not presently debarred, suspended, proposed for debarment, declared ineligible, or voluntarily excluded from participating in covered transactions by any Federal department or agency;

(2) Have not within a three-year period preceding this proposal been convicted of or had a civil judgment rendered against them for commission of fraud or a criminal offense in connection with obtaining, attempting to obtain, or performing a public (Federal, State or local) transaction or contract under a public transaction; violation of Federal or State antitrust statutes or commission of embezzlement, theft, forgery, bribery, falsification or destruction of records, making false statements, or receiving stolen property;

(3) Are not presently indicted for or otherwise criminally or civilly charged by a governmental entity (Federal, State or local) with commission of any of the offenses enumerated in paragraph (a)(2) of this certification; and

(4) Have not within a three-year period preceding this application/proposal had one or more public transactions (Federal, State or local) terminated for cause or default.

b. Where the prospective participant is unable to certify to any of the statements in this certification, such prospective participant shall attach an explanation to this proposal.

2. Instructions for Certification - Lower Tier Participants:

(Applicable to all subcontracts, purchase orders and other lower tier transactions requiring prior FHWA approval or estimated to cost \$25,000 or more - 2 CFR Parts 180 and 1200)

a. By signing and submitting this proposal, the prospective lower tier is providing the certification set out below.

b. The certification in this clause is a material representation of fact upon which reliance was placed when this transaction was entered into. If it is later determined that the prospective lower tier participant knowingly rendered an erroneous certification, in addition to other remedies available to the Federal Government, the department, or agency with which

this transaction originated may pursue available remedies, including suspension and/or debarment.

c. The prospective lower tier participant shall provide immediate written notice to the person to which this proposal is submitted if at any time the prospective lower tier participant learns that its certification was erroneous by reason of changed circumstances.

d. The terms "covered transaction," "debarred," "suspended," "ineligible," "participant," "person," "principal," and "voluntarily excluded," as used in this clause, are defined in 2 CFR Parts 180 and 1200. You may contact the person to which this proposal is submitted for assistance in obtaining a copy of those regulations. "First Tier Covered Transactions" refers to any covered transaction between a grantee or subgrantee of Federal funds and a participant (such as the prime or general contract). "Lower Tier Covered Transactions" refers to any covered transaction under a First Tier Covered Transaction (such as subcontracts). "First Tier Participant" refers to the participant who has entered into a covered transaction with a grantee or subgrantee of Federal funds (such as the prime or general contractor). "Lower Tier Participant" refers to any participant who has entered into a covered transaction with a First Tier Participant or other Lower Tier Participants (such as subcontractors and suppliers).

e. The prospective lower tier participant agrees by submitting this proposal that, should the proposed covered transaction be entered into, it shall not knowingly enter into any lower tier covered transaction with a person who is debarred, suspended, declared ineligible, or voluntarily excluded from participation in this covered transaction, unless authorized by the department or agency with which this transaction originated.

f. The prospective lower tier participant further agrees by submitting this proposal that it will include this clause titled "Certification Regarding Debarment, Suspension, Ineligibility and Voluntary Exclusion-Lower Tier Covered Transaction," without modification, in all lower tier covered transactions and in all solicitations for lower tier covered transactions exceeding the \$25,000 threshold.

g. A participant in a covered transaction may rely upon a certification of a prospective participant in a lower tier covered transaction that is not debarred, suspended, ineligible, or voluntarily excluded from the covered transaction, unless it knows that the certification is erroneous. A participant is responsible for ensuring that its principals are not suspended, debarred, or otherwise ineligible to participate in covered transactions. To verify the eligibility of its principals, as well as the eligibility of any lower tier prospective participants, each participant may, but is not required to, check the Excluded Parties List System website (<https://www.epls.gov/>), which is compiled by the General Services Administration.

h. Nothing contained in the foregoing shall be construed to require establishment of a system of records in order to render in good faith the certification required by this clause. The knowledge and information of participant is not required to exceed that which is normally possessed by a prudent person in the ordinary course of business dealings.

i. Except for transactions authorized under paragraph e of these instructions, if a participant in a covered transaction knowingly enters into a lower tier covered transaction with a person who is suspended, debarred, ineligible, or voluntarily excluded from participation in this transaction, in addition to other remedies available to the Federal Government, the

department or agency with which this transaction originated may pursue available remedies, including suspension and/or debarment.

Certification Regarding Debarment, Suspension, Ineligibility and Voluntary Exclusion--Lower Tier Participants:

1. The prospective lower tier participant certifies, by submission of this proposal, that neither it nor its principals is presently debarred, suspended, proposed for debarment, declared ineligible, or voluntarily excluded from participating in covered transactions by any Federal department or agency.

2. Where the prospective lower tier participant is unable to certify to any of the statements in this certification, such prospective participant shall attach an explanation to this proposal.

XI. CERTIFICATION REGARDING USE OF CONTRACT FUNDS FOR LOBBYING

This provision is applicable to all Federal-aid construction contracts and to all related subcontracts which exceed \$100,000 (49 CFR 20).

1. The prospective participant certifies, by signing and submitting this bid or proposal, to the best of his or her knowledge and belief, that:

a. No Federal appropriated funds have been paid or will be paid, by or on behalf of the undersigned, to any person for influencing or attempting to influence an officer or employee of any Federal agency, a Member of Congress, an officer or employee of Congress, or an employee of a Member of Congress in connection with the awarding of any Federal contract, the making of any Federal grant, the making of any Federal loan, the entering into of any cooperative agreement, and the extension, continuation, renewal, amendment, or modification of any Federal contract, grant, loan, or cooperative agreement.

b. If any funds other than Federal appropriated funds have been paid or will be paid to any person for influencing or attempting to influence an officer or employee of any Federal agency, a Member of Congress, an officer or employee of Congress, or an employee of a Member of Congress in connection with this Federal contract, grant, loan, or cooperative agreement, the undersigned shall complete and submit Standard Form-LLL, "Disclosure Form to Report Lobbying," in accordance with its instructions.

2. This certification is a material representation of fact upon which reliance was placed when this transaction was made or entered into. Submission of this certification is a prerequisite for making or entering into this transaction imposed by 31 U.S.C. 1352. Any person who fails to file the required certification shall be subject to a civil penalty of not less than \$10,000 and not more than \$100,000 for each such failure.

3. The prospective participant also agrees by submitting its bid or proposal that the participant shall require that the language of this certification be included in all lower tier subcontracts, which exceed \$100,000 and that all such recipients shall certify and disclose accordingly.

Replace "working days" in the 1st paragraph of section 8-1.02D(1) with:

10-19-12

original working days

Replace "8-1.02D(1)" in the 2nd paragraph of section 8-1.02D(1) with:

01-20-12

8-1.02C(1)

Replace "Contract" in the 3rd paragraph of section 8-1.02D(2) with:

10-19-12

work

Replace "Contract" in item 9 in the list in the 4th paragraph of section 8-1.02D(4) with:

10-19-12

work

Replace "Contract completion" in the 4th paragraph of section 8-1.02D(6) with:

10-19-12

work completion

Replace "Contract working days" in the 4th paragraph of section 8-1.02D(6) with:

10-19-12

original working days

04-20-12

Delete items 1.3 and 1.4 in the list in the 1st paragraph of section 8-1.02D(10).

Replace the last paragraph of section 8-1.04B with:

10-19-12

The Department does not adjust time for starting before receiving notice of Contract approval.

Replace the 1st paragraph of section 8-1.05 with:

10-19-12

Contract time starts on the last day specified to start job site activities in section 8-1.04 or on the day you start job site activities, whichever occurs first.

Replace the 2nd paragraph of section 8-1.05 with:

10-19-12

Complete the work within the Contract time.

Delete "unless the Contract is suspended for reasons unrelated to your performance" in the 4th paragraph of section 8-1.05.

Replace the headings and paragraphs in section 8-1.06 with:

10-19-12

The Engineer may suspend work wholly or in part due to conditions unsuitable for work progress. Provide for public safety and a smooth and unobstructed passageway through the work zone during the suspension as specified under sections 7-1.03 and 7-1.04. Providing the passageway is force account work. The Department makes a time adjustment for the suspension due to a critical delay.

The Engineer may suspend work wholly or in part due to your failure to (1) fulfill the Engineer's orders, (2) fulfill a Contract part, or (3) perform weather-dependent work when conditions are favorable so that weather-related unsuitable conditions are avoided or do not occur. The Department may provide for a smooth and unobstructed passageway through the work during the suspension and deduct the cost from payments. The Department does not make a time adjustment for the suspension.

Upon the Engineer's order of suspension, suspend work immediately. Resume work when ordered.

Replace the 1st sentence in the 1st paragraph of section 8-1.07B with:

10-19-12

For a critical delay, the Department may make a time adjustment.

Add to the end of section 8-1.07C:

10-19-12

The Department does not make a payment adjustment for overhead incurred during non-working days that extend the Contract into an additional construction season.

Replace the 1st paragraph of section 8-1.07C with:

10-19-12

For an excusable delay that affects your costs, the Department may make a payment adjustment.

Replace "8-1.08B and 8-1.08C" in the 1st paragraph of section 8-1.10A with:

08-05-11

8-1.10B and 8-1.10C

Replace section 8-1.10D with:

10-19-12

8-1.10D Reserved

^^

9 PAYMENT

01-23-15

Add to the list in the 1st paragraph of section 9-1.03:

07-19-13

3. Any royalties and costs arising from patents, trademarks, and copyrights involved in the work

Replace item 1 in the 3rd paragraph of section 9-1.03 with:

01-18-13

1. Full compensation for all work involved in each bid item shown on the Bid Item List by the unit of measure shown for that bid item

Replace "10" in the last paragraph of section 9-1.03 with:

01-23-15

7

Replace "in" in the 3rd paragraph of section 9-1.04A with:

10-19-12

for

Add to the end of section 9-1.04A:

10-19-12

For nonsubcontracted work paid by force account for a contract with a TRO bid item, the markups are those shown in the following table instead of those specified in sections 9-1.04B–D:

Cost	Percent markup
Labor	30
Materials	10
Equipment rental	10

Replace the heading and the 1st paragraph of section 9-1.04D(3) with:

01-23-15

9-1.04D(3) Equipment Not On the Job Site and Not Required for Original Contract Work

For equipment not on the job site at the time required to perform work paid by force account and not required for original Contract work, the time paid is the time the equipment is operated to perform work paid by force account and the time to return the equipment to its source when the work paid by force account is completed.

Replace item 2 in the 3rd paragraph of section 9-1.04D(3) with:

01-23-15

2. Operated less than 4 hours is paid as 1/2 day

Replace section 9-1.04D(4) with:

01-23-15

9-1.04D(4) Equipment Not On the Job Site and Required for Original Contract Work

For equipment not on the job site at the time required to perform work paid by force account and required for original Contract work, the time paid is the time:

1. To move the equipment to the location of work paid by force account plus an equal amount of time to move the equipment to a location on the job site or its source when the work paid by force account is completed
2. Equipment is operated to perform work paid by force account

04-20-12

Delete ", Huntington Beach," in the 3rd paragraph of section 9-1.07A.

Replace the formula in section 9-1.07B(2) with:

04-20-12

$$Qh = HMATT \times Xa$$

Replace "weight of dry aggregate" in the definition of the variable Xa in section 9-1.07B(2) with:

04-20-12

total weight of HMA

Replace the formula in section 9-1.07B(3) with:

04-20-12

$$Qrh = RHMATT \times 0.80 \times Xarb$$

Replace "weight of dry aggregate" in the definition of the variable $Xarb$ in section 9-1.07B(3) with:

04-20-12

total weight of rubberized HMA

Replace the heading of section 9-1.07B(4) with:

04-20-12

Hot Mix Asphalt with Modified Asphalt Binder

Add between "in" and "modified" in the introductory clause of section 9-1.07B(4):

04-20-12

HMA with

Replace the formula in section 9-1.07B(4) with:

04-20-12

$$Q_{mh} = MHMATT \times [(100 - X_{am}) / 100] \times X_{mab}$$

Replace "weight of dry aggregate" in the definition of the variable X_{mab} in section 9-1.07B(4) with:

04-20-12

total weight of HMA

Replace the formula in section 9-1.07B(5) with:

04-20-12

$$Q_{rap} = HMATT \times X_{aa}$$

Replace "weight of dry aggregate" in the definitions of the variables X_{aa} and X_{fa} in section 9-1.07B(5) with:

04-20-12

total weight of HMA

Add after the variable definitions in section 9-1.07B(9):

04-20-12

The quantity of extender oil is included in the quantity of asphalt.

Replace the headings and paragraphs in section 9-1.11 with:

10-19-12

9-1.11A General

Section 9-1.11 applies if a bid item for time-related overhead is included in the Contract. If a bid item for time-related overhead is included, you must exclude the time-related overhead from every other bid item price.

9-1.11B Payment Quantity

The TRO quantity does not include the number of working days to complete plant establishment work.

For a contract with a TRO lump sum quantity on the Bid Item List, the Department pays you based on the following conversions:

1. LS unit of measure is replaced with WDAY
2. Lump sum quantity is replaced with the number of working days bid
3. Lump sum unit price is replaced with the item total divided by the number of working days bid

9-1.11C Payment Inclusions

Payment for the TRO bid item includes payment for time-related field- and home-office overhead for the time required to complete the work.

The field office overhead includes time-related expenses associated with the normal and recurring construction activities not directly attributed to the work, including:

1. Salaries, benefits, and equipment costs of:
 - 1.1. Project managers
 - 1.2. General superintendents
 - 1.3. Field office managers
 - 1.4. Field office staff assigned to the project
2. Rent
3. Utilities
4. Maintenance
5. Security
6. Supplies
7. Office equipment costs for the project's field office

The home-office overhead includes the fixed general and administrative expenses for operating your business, including:

1. General administration
2. Insurance
3. Personnel and subcontract administration
4. Purchasing
5. Accounting
6. Project engineering and estimating

Payment for the TRO bid item does not include payment for:

1. The home-office overhead expenses specifically related to:
 - 1.1. Your other contracts or other businesses
 - 1.2. Equipment coordination
 - 1.3. Material deliveries
 - 1.4. Consultant and legal fees
2. Non-time-related costs and expenses such as mobilization, licenses, permits, and other charges incurred once during the Contract
3. Additional overhead involved in incentive/disincentive provisions to satisfy an internal milestone or multiple calendar requirements
4. Additional overhead involved in performing additional work that is not a controlling activity
5. Overhead costs incurred by your subcontractors of any tier or suppliers

9-1.11D Payment Schedule

For progress payments, the total work completed for the TRO bid item is the number of working days shown for the pay period on the *Weekly Statement of Working Days*.

For progress payments, the Department pays a unit price equal to the lesser of the following amounts:

1. Price per working day as bid or as converted under section 9-1.11B.
2. 20 percent of the total bid divided by the number of original working days

For a contract without plant establishment work, the Department pays you the balance due of the TRO item total as specified in section 9-1.17B.

For a contract with plant establishment work, the Department pays you the balance due of the TRO item total in the 1st progress payment after all non-plant establishment work is completed.

9-1.11E Payment Adjustments

The 3rd paragraph of section 9-1.17C does not apply.

The Department does not adjust the unit price for an increase or decrease in the TRO quantity except as specified in section 9-1.11E.

Section 9-1.17D(2)(b) does not apply except as specified for the audit report below.

If the TRO bid item quantity exceeds 149 percent of the quantity shown on the Bid Item List or as converted under section 9-1.11B, the Engineer may adjust or you may request an adjustment of the unit price for the excess quantity. For the adjustment, submit an audit report within 60 days of the Engineer's request. The report must be prepared as specified for an audit report for an overhead claim in section 9-1.17D(2)(b).

Within 20 days of the Engineer's request, make your financial records available for an audit by the State for the purpose of verifying the actual rate of TRO described in your audit. The actual rate of TRO described is subject to the Engineer's authorization.

The Department pays the authorized actual rate for TRO in excess of 149 percent of the quantity shown on the Bid Item List or as converted under section 9-1.11B.

The Department pays for 1/2 the cost of the report; the Contractor pays for the other 1/2. The cost is determined under section 9-1.05.

Replace the paragraphs of section 9-1.16D with:

07-19-13

9-1.16D(1) General

Section 9-1.16D applies if a bid item for mobilization is shown on the Bid Item List.

Payments for mobilization made under section 9-1.16D are in addition to the partial payments made under Pub Cont Code § 10261.

Section 9-1.16D(2) applies unless the Contract includes a special provision for section 9-1.16D(1) that specifies section 9-1.16D(3) applies.

9-1.16D(2) Mobilization for Projects Except for Those Over Water Requiring Marine Access

07-19-13

The Department makes partial payments for mobilization under Pub Cont Code § 10264(a) except the amount of work completed does not include the amount earned for mobilization. The partial payment amount is reduced by a prorated amount bid in excess of the maximum allowed under Pub Cont Code § 10264(a)(5).

The Department pays the item total for mobilization in excess of the maximum allowed under Pub Cont Code § 10264(a)(5) in the 1st payment after Contract acceptance.

9-1.16D(3) Mobilization for Projects Over Water Requiring Marine Access

The Department makes partial payments for mobilization under Pub Cont Code § 10264(b) except the amount of work completed does not include the amount earned for mobilization. The partial payment amount is reduced by a prorated amount bid in excess of the maximum allowed under Pub Cont Code § 10264(b)(6).

The Department pays the item total for mobilization in excess of the maximum allowed under Pub Cont Code § 10264(b)(6) in the 1st payment after Contract acceptance.

10-19-12

Delete "revised Contract" in item 1 of the 1st paragraph of section 9-1.16E(2).

Replace "3179" in the 1st paragraph of section 9-1.16E(4) with:

01-23-15

9000

Replace "2014" in the 1st paragraph of section 9-1.16F with:

10-19-12

2020

Replace the 2nd paragraph of section 9-1.17C with:

10-19-12

Submit either a written acceptance of the proposed final estimate or a claim statement postmarked or hand delivered before the 31st day after receiving the proposed final estimate.

Add between "the" and "final estimate" in the 1st sentence in the 3rd paragraph of section 9-1.17C:

10-19-12

proposed

Replace the 1st sentence in the 6th paragraph of section 9-1.17D(2)(b) with:

07-19-13

The CPA's audit must be performed as an examination-level engagement under the attestation engagements in the *Government Auditing Standards* published by the Comptroller General of the United States.

AA

DIVISION II GENERAL CONSTRUCTION

10 GENERAL

05-30-14

Replace the headings and paragraphs in section 10 with:

04-19-13

10-1 GENERAL

10-1.01 GENERAL

Section 10 includes general specifications for general construction work.

10-1.02 WORK SEQUENCING

Before obliterating any traffic stripes, pavement markings, and pavement markers to be replaced at the same location, reference the stripes, markings, and markers. Include limits and transitions with control points to reestablish the new stripes, markings, and markers.

10-1.03 TIME CONSTRAINTS

Reserved

10-1.04 TRAINING AND MEETINGS

Training and meetings are held at times and locations you and the Engineer agree to.

10-1.05–10-1.10 RESERVED

10-2 SUSTAINABLE DESIGN REQUIREMENTS

10-2.01 GENERAL

10-2.01A General

Reserved

10-2.01B–10-2.01H Reserved

10-2.02 CALGREEN TIER 1

10-2.02A–10-2.02H Reserved

10-2.03 LEED

10-2.03A–10-2.03H Reserved

10-3 RESERVED

Replace section 10-4 with:

05-30-14

10-4 WATER USAGE

Section 10-4 includes general specifications for your use of water for construction activities.

The Department encourages you to conserve water in all construction activities.

The Engineer notifies you of any (1) water shortage or (2) mandate from a local water authority to ration water. Within 10 days of the notification, submit a water conservation plan. The plan must include:

1. List of construction activities that require water
2. Measures you will implement for each activity to conserve water
3. Method for curing concrete other than the water method if included in the work
4. Dust palliative you will use for dust control

Any unavailability of water that delays a controlling activity is a material shortage.

Replace section 10-5 with:

05-30-14

10-5 DUST CONTROL

Section 10-5 includes general specifications for controlling dust resulting from the work.

Prevent and alleviate dust by:

1. Applying a dust palliative under section 18
2. Applying temporary soil stabilization under section 13-5
3. Managing material stockpiles under section 13-4.03C(3)

04-19-13

10-6 JOB SITE WATER CONTROL

10-6.01 GENERAL

Section 10-6 includes specifications for controlling water to provide a dry working area at the job site.

10-6.02 WATER-FILLED COFFERDAM

Reserved

10-6.03–10-6.10 RESERVED

10-7–10-20 RESERVED

AA

11 QUALITY CONTROL AND ASSURANCE

07-19-13

Replace section 11-2 with:

07-19-13

11-2 RESERVED

Replace the table in the 3rd paragraph of section 11-3.01A with:

07-19-13

AWS code	Year of adoption
D1.1	2010
D1.3	2008
D1.4	2011
D1.5	2010
D1.6	2007
D1.8	2009

Replace "does" in the definition of "continuous inspection" in section 11-3.01B with:

07-19-13

do

Replace "gross nonconformance" and its definition in section 11-3.01B with:

07-19-13

gross nonconformance: Rejectable indications are present in more than 20 percent of the tested weld length.

Replace the introductory clause in the 1st paragraph of section 11-3.01C with:

07-19-13

Replace clause 6.1.3 of AWS D1.1, the 1st paragraph of clause 7.1.2 of AWS D1.4, and clause 6.1.2 of AWS D1.5 with:

Replace the 3rd paragraph of section 11-3.01C with:

07-19-13

For each inspection, including fit-up, WPS verification, and final weld inspection, the QC Inspector must confirm and document compliance with the specifications, AWS welding codes, and any referenced drawings.

Replace the paragraphs in section 11-3.01D with:

07-19-13

The Engineer has the authority to verify the qualifications or certifications of any welder, QC Inspector, or NDT personnel to specified levels by retests or other means determined by the Engineer. If welding will be performed without gas shielding, then qualification must also include welding without gas shielding.

Replace clause 6.14.6.1 of AWS D1.1, clause 7.8 of AWS D1.4, and clause 6.1.3.4 of AWS D1.5 with:

Personnel performing NDT must be qualified and certified under American Society for Nondestructive Testing (ASNT) Recommended Practice No. SNT-TC-1A and the written practice of the NDT firm. The written practice of the NDT firm must comply with or exceed the guidelines of the ASNT Recommended Practice No. SNT-TC-1A. Individuals who perform NDT, review the results, and prepare the written reports must be one of the following:

1. Certified NDT Level II technicians
2. Level III technicians certified to perform the work of Level II technicians

Replace the heading and the 1st through 3rd paragraphs of section 11-3.01E with:

07-19-13

11-3.01E Weld Joint Details

If weld joint details proposed for use in the work are not prequalified under clause 3 of AWS D1.1 or figure 2.4 or 2.5 of AWS D1.5, submit the proposed WPS and the intended weld joint locations.

Upon authorization of the proposed joint detail locations and qualification of the proposed joint details, welders and welding operators using these details must weld an additional qualification test plate using the WPS variables and the weld joint detail to be used in production. The test plate must:

1. Have the maximum thickness to be used in production and a minimum length of 18 inches.
2. Be mechanically and radiographically tested. Mechanical and radiographic testing and acceptance criteria must comply with the applicable AWS codes.

If a nonprequalified weld joint configuration is proposed using a combination of WPSs for work welded under AWS D1.1, you may conduct a single test combining the WPSs to be used in production, if the essential variables, including weld bead placement, of each process are limited to those established in table 4.5 of AWS D1.1.

Replace the 1st paragraph of section 11-3.01F with:

07-19-13

Replace paragraph 3 of clause 6.26.3.2 of AWS D1.5 with:

3. If indications that exhibit these planar characteristics are present at scanning sensitivity, or other evidence exists to suggest the presence of transverse cracks, a more detailed evaluation of the discontinuity by other means must be performed (e.g., alternate UT techniques, RT, grinding, or gouging for visual inspection or MT of the excavated areas.). For welds that have transverse cracks, excavate the full length of the crack plus 2 inches of weld metal on each side adjacent to the crack and reweld.

Replace "section" in the 2nd paragraph of section 11-3.01F with:

07-19-13

clause

Replace the 1st paragraph of section 11-3.02A with:

07-19-13

Except for stud welding, section 11-3.02 applies to (1) work welded under sections 49, 52, 55, and 75-1.03E and (2) work in section 99 that must comply with an AWS welding code.

Replace the 4th through 6th paragraphs of section 11-3.02C(2) with:

07-19-13

Submit an amended welding QC plan or an addendum to the welding QC plan for any changes to:

1. WPSs
2. NDT firms
3. QC personnel or procedures
4. NDT personnel or procedures
5. Systems for tracking and identifying welds
6. Welding personnel

Allow 15 days for the Engineer's review of an amended welding QC plan or an addendum to the welding QC plan.

Submit 7 copies of each authorized QC plan and any authorized addendums. Make 1 copy available at each location where work is performed.

Replace the 1st paragraph of section 11-3.02C(3) with:

07-19-13

Submit a welding report within 7 days following the performance of any welding. The welding report must include:

1. Daily production log for welding for each day that welding is performed
2. Reports of all visual weld inspections and NDT performed, whether specified, additional, or informational
3. Radiographs and radiographic reports, and other required NDT reports
4. Summary of welding and NDT activities that occurred during the reporting period
5. Reports of each application of heat straightening
6. Summarized log listing the rejected lengths of weld by welder, position, process, joint configuration, and piece number
7. Documentation that you have:
 - 7.1. Evaluated all radiographs and radiograph reports and NDT and NDT reports
 - 7.2. Corrected all rejectable deficiencies and that all repaired welds have been reexamined using the required NDT and found acceptable
8. Reports or chart recordings of each application of any stress relieving used
9. Reports and chart recordings for any electroslag welding used

Add between "radiographic" and "envelopes" in the introductory clause in the 3rd paragraph of section 11-3.02C(3):

07-19-13

film

Delete the 3rd sentence in the 5th paragraph of section 11-3.02C(3).

Replace the introductory clause in the 1st paragraph of section 11-3.02D with:

07-19-13

Clauses 6.1.4.1 and 6.1.4.3 of AWS D1.1, the 2nd paragraph of clause 7.1.2 of AWS D1.4, clauses 6.1.3.1 through 6.1.3.3 of AWS D1.5, and clause 7.2.3 of AWS D1.8 are replaced with:

Replace items 1 and 2 in the list in the 2nd paragraph of section 11-3.02D with:

07-19-13

1. Work is welded at a permanent fabrication or manufacturing plant that is certified under the AISC Certification Program for Steel Bridge Fabricators, Intermediate Bridges, and Fracture-Critical Member endorsement if required.
2. Structural steel for building construction work is performed at a permanent fabrication or manufacturing plant that is certified under the AISC Quality Certification Program, Category STD, Standard for Steel Building Structures.

07-19-13

Delete the 3rd paragraph of section 11-3.02D.

Replace the 1st sentence in the 4th paragraph of section 11-3.02D with:

07-19-13

Except for the exempt facilities identified above, an authorized independent third party must witness the qualification tests for welders or welding operators.

Replace the paragraph in section 11-3.02F with:

07-19-13

Welding procedures qualification for work welded under AWS D1.5 must comply with clause 5.12 or 5.12.4 of AWS D1.5 and the following:

1. Unless considered prequalified, qualify fillet welds in each position. Conduct the fillet weld soundness test using the essential variables of the WPS as established by the PQR.
2. For qualifying joints that do not comply with figures 2.4 and 2.5 of AWS D1.5, conduct the test complying with figure 5.3 using the welding parameters that were established for the test conducted complying with figure 5.1.
3. Macroetch tests are required for WPS qualification tests, and acceptance must comply with clause 5.19.3 of AWS D1.5.
4. If a nonstandard weld joint is to be made using a combination of WPSs, you may conduct a test under figure 5.3, combining the qualified or prequalified WPSs to be used in production, if the essential variables, including weld bead placement, of each process are limited to those established in table 5.3 of AWS D1.5.
5. Before preparing mechanical test specimens, inspect the PQR welds by visual and radiographic tests. The backing bar must be 3 inches in width and must remain in place during NDT. Results of the

visual and radiographic tests must comply with clause 6.26.2 of AWS D1.5 excluding clause 6.26.2.2. All other requirements for clause 5.17 are applicable.

Add to the list in the 3rd paragraph of section 11-3.02G:

07-19-13

- 3. Repairs not included in the welding QC plan

Replace the 1st sentence of the 4th paragraph of section 11-3.02G with:

07-19-13

Requests to perform 3rd-time excavations, repairs of cracks, or repairs not included in the welding QC plan must include an engineering evaluation.

^^

12 TEMPORARY TRAFFIC CONTROL

05-30-14

Replace the 5th paragraph of section 12-3.01A(1) with:

05-30-14

Repair or replace traffic-handling equipment and devices damaged from any cause during the Contract, including repainting if necessary. The condition of temporary traffic control devices must comply with the current American Traffic Safety Services Association publication "Quality Guidelines for Temporary Traffic Control Devices and Features."

Replace the 1st paragraph of section 12-3.01A(4) with:

10-19-12

Category 2 temporary traffic control devices must be on FHWA's list of acceptable, crashworthy Category 2 hardware for work zones. This list is available on FHWA's Safety Program Web site.

Replace "project" in the 4th paragraph of section 12-3.02C with:

10-19-12

work

Add after "Display" in item 4 in the list in the 2nd paragraph of section 12-3.03B:

04-19-13

or Alternating Diamond

Replace "project" in the 3rd paragraph of section 12-3.07C with:

10-19-12

work

Add to section 12-3:

07-19-13

12-3.18 AUTOMATED WORK ZONE INFORMATION SYSTEM

Reserved

12-3.19–12-3.25 RESERVED

Replace the 7th through 9th paragraphs of section 12-4.02A with:

07-19-13

If pedestrian traffic is allowed to pass through construction areas, provide a temporary pedestrian facility through the construction areas within the highway. Include protective overhead covering as necessary to ensure protection from falling objects and drippings from overhead structures.

At locations where pedestrian openings through falsework are required, provide a temporary pedestrian facility with protective overhead covering during all bridge construction activities.

Temporary pedestrian facilities must comply with section 12-7.

If an activity requires a closure of a walkway, another walkway must be made available nearby, off of the traveled way.

07-19-13

Delete the 12th paragraph of section 12-4.02A.

Replace section 12-4.03 with:

07-19-13

12-4.03 CLOSURE SCHEDULES AND CONDITIONS

12-4.03A General

Submit closure schedule requests and closure schedule amendments using LCS to show the locations and times of the requested closures.

The Department provides LCS training. Request the LCS training at least 30 days before submitting the 1st lane closure request. The Department provides the training within 15 days after your request. The training may be web based.

Except for web-based training, the training is held at a time and location you and the Engineer agree to.

For web-based training, the Engineer provides you the website address to access the training.

Within 5 business days after completion of the training, the Department provides LCS accounts and user identifications to your assigned, trained representatives.

Each representative must maintain a unique password and current user information in the LCS.

12-4.03B Closure Schedules

Every Monday by noon, submit a closure schedule request of planned closures for the next week period. The next week period is defined as Sunday noon through the following Sunday noon.

Submit a closure schedule request not less than 25 days and not more than 125 days before the anticipated start of any activity that reduces:

1. Horizontal clearances of traveled ways, including shoulders, to 2 lanes or less due to activities such as temporary barrier placement and paving
2. Vertical clearances of traveled way, including shoulders, due to activities such as pavement overlays, overhead sign installation, falsework, or girder erection

Submit closure schedule amendments, including adding additional closures, by noon at least 3 business days before a planned closure.

Cancel closure requests using LCS at least 48 hours before the start time of the closure.

You will be notified through LCS of unauthorized closures or closures that require coordination with other parties as a condition for authorization.

The Engineer may reschedule a closure cancelled due to unsuitable weather.

If a closure is not opened to traffic by the specified time, suspend work. No further closures are allowed until the Engineer has reviewed and authorized a work plan submitted by you that ensures that future closures will be opened to traffic by the specified time. Allow 2 business days for review of your proposed work plan. The Department does not compensate you for your losses due to the suspension of work resulting from the late opening of closures.

Notify the Engineer of delays in your activities caused by:

1. Your closure schedule request being denied although your requested closures are within the specified time frame allowed for closures. The Department does not compensate you for your losses due to amendments to the closure schedule that are not authorized.
2. Your authorized closure being denied.

If you are directed to remove a closure before the time designated in the authorized closure schedule, you will be compensated for the delay.

12-4.03C Contingency Plan

Section 12-4.03C applies if a contingency plan is specified in the special provisions or if a contingency plan is requested.

If a contingency plan is requested, submit the contingency plan within 1 business day of the request.

The contingency plan must identify the activities, equipment, processes, and materials that may cause a delay in the opening of a closure to traffic. The plan must include:

1. List of additional or alternate equipment, materials, or workers necessary to ensure continuing activities and on-time opening of closures if a problem occurs. If the additional or alternate equipment, materials, or workers are not on site, specify their location, the method for mobilizing these items, and the required time to complete mobilization.
2. General time-scaled logic diagram displaying the major activities and sequence of planned operations. For each activity, identify the critical event when the contingency plan will be activated.

Based on the Engineer's review, additional materials, equipment, workers, or time to complete activities from that specified in the contingency plan may be required.

Submit revisions to a contingency plan at least 3 business days before starting the activity requiring a contingency plan. Allow 2 business days for review of the revised contingency plan.

Add to section 13-1.01A:

11-15-13

Comply with the Department's general permit issued by the State Water Resources Control Board for *Order No. 2012-0011-DWQ, NPDES No. CAS000003, National Pollutant Discharge Elimination System (NPDES) Permit, Statewide Storm Water Permit and Waste Discharge Requirements (WDRs) for the State of California, Department of Transportation (Caltrans)*. The Department's general permit governs stormwater and nonstormwater discharges from the Department's properties, facilities, and activities. The Department's general permit may be viewed at the Web site for the State Water Resources Control Board, Storm Water Program, Caltrans General Permit.

Add to the list in the 1st paragraph of section 13-1.01D(3)(b):

10-21-11

3. Have completed SWRCB approved QSD training and passed the QSD exam

Add to the list in the 2nd paragraph of section 13-1.01D(3)(b):

10-21-11

3. Have completed SWRCB approved QSP training and passed the QSP exam

Replace "NEL violation" in item 3.6.2 in the list in the 1st paragraph of section 13-1.01D(3)(c) with:

04-19-13

receiving water monitoring trigger

Replace the 1st paragraph in section 13-2.01B with:

04-19-13

Within 7 days after Contract approval, submit 2 copies of your WPCP for review. Allow 5 business days for review.

After the Engineer authorizes the WPCP, submit an electronic copy and 3 printed copies of the authorized WPCP.

If the RWQCB requires review of the authorized WPCP, the Engineer submits the authorized WPCP to the RWQCB for its review and comment. If the Engineer orders changes to the WPCP based on the RWQCB's comments, amend the WPCP within 3 business days.

Replace the 1st paragraph in section 13-3.01B(2)(a) with:

04-19-13

Within 15 days of Contract approval, submit 3 copies of your SWPPP for review. The Engineer provides comments and specifies the date when the review stopped if revisions are required. Change and resubmit a revised SWPPP within 15 days of receiving the Engineer's comments. The Department's review resumes when a complete SWPPP has been resubmitted.

When the Engineer authorizes the SWPPP, submit an electronic copy and 4 printed copies of the authorized SWPPP.

If the RWQCB requires review of the authorized SWPPP, the Engineer submits the authorized SWPPP to the RWQCB for its review and comment. If the Engineer requests changes to the SWPPP based on the RWQCB's comments, amend the SWPPP within 10 days.

Replace "NELs" in item 3.1 in the 3rd paragraph of section 13-3.01B(2)(a) with:

04-19-13

receiving water monitoring triggers

Replace section 13-3.01B(6)(c) with:

04-19-13

13-3.01B(6)(c) Receiving Water Monitoring Trigger Report

Whenever a receiving water monitoring trigger is exceeded, notify the Engineer and submit a receiving water monitoring trigger report within 48 hours after conclusion of a storm event. The report must include:

1. Field sampling results and inspections, including:
 - 1.1. Analytical methods, reporting units, and detection limits
 - 1.2. Date, location, time of sampling, visual observation and measurements
 - 1.3. Quantity of precipitation from the storm event
2. Description of BMPs and corrective actions

Replace "NEL" in the 6th paragraph of section 13-3.01C(1) with:

04-19-13

receiving water monitoring trigger

Replace section 13-3.01C(3) with:

04-19-13

13-3.01C(3) Receiving Water Monitoring Trigger

For a risk level 3 project, receiving water monitoring triggers must comply with the values shown in the following table:

Receiving Water Monitoring Trigger

Parameter	Test method	Detection limit (min)	Unit	Value
pH	Field test with calibrated portable instrument	0.2	pH	Lower limit = 6.0 Upper limit = 9.0
Turbidity	Field test with calibrated portable instrument	1	NTU	500 NTU max

The storm event daily average for storms up to the 5-year, 24-hour storm must not exceed the receiving water monitoring trigger for turbidity.

The daily average sampling results must not exceed the receiving water monitoring trigger for pH.

04-19-13

Delete "and NELs are violated" in the 3rd paragraph of section 13-3.03C.

Replace "working days" at each occurrence in section 13-3.04 with.

10-19-12

original working days

04-19-13

Delete the 1st sentence in the 2nd paragraph of section 13-4.03C(3).

Add between the 2nd and 3rd paragraphs of section 13-4.03C(3):

04-19-13

Manage stockpiles by implementing water pollution control practices on:

1. Active stockpiles before a forecasted storm event
2. Inactive stockpiles according to the WPCP or SWPPP schedule

05-30-14

Delete the 7th paragraph of section 13-4.03C(3).

Replace the heading of section 13-4.03E(1) with:

05-30-14

General

05-30-14

Delete the 1st through 5th sentences in the 2nd paragraph of section 13-4.03E(1).

Replace the 1st sentence of the 1st paragraph of section 13-4.03E(3) with:

05-30-14

Limit vehicle and equipment cleaning or washing at the job site to that needed for safety and protection of the equipment and compliance with PLACs.

Replace the paragraph in section 13-4.04 with:

04-20-12

Not Used

Replace "20-7.02D(6)" in section 13-5.02C with:

07-19-13

20-5.03E

10-19-12

Delete "or stockpile" in the 3rd paragraph of section 13-5.02F.

Replace "20-7.03I(10)" in section 13-5.03C with:

07-19-13

20-5.03E(3)

Replace section 13-5.03F with:

04-20-12

13-5.03F Reserved

10-19-12

Delete "or stockpile" in item 1 in the list in the 1st paragraph of section 13-5.03K.

10-19-12

Delete the 3rd paragraph of section 13-5.03K.

Replace the 2nd sentence in the 1st paragraph of section 13-9.01A with:

10-19-12

You may use any of the following systems for temporary concrete washout:

1. Temporary concrete washout facility
2. Portable temporary concrete washout
3. Temporary concrete washout bin

Replace the 2nd paragraph of section 13-9.01B with:

10-19-12

Retain and submit an informational submittal for records of disposed concrete waste.

10-19-12

Delete the 4th paragraph of section 13-9.01B.

10-19-12

Delete "if authorized" in the 1st sentence in the 1st paragraph of section 13-9.02A.

Add to section 15-2.02B:

07-19-13

15-2.02B(5) Remove Concrete Pavement

15-2.02B(5)(a) General

Remove only the portion of pavement to be replaced or repaired during the same lane closure. If there is overlying material on the concrete pavement, remove it with the pavement.

Do not impact the surface within 18 inches of the pavement to remain in place. Use removal methods that do not damage the remaining pavement and base. Slab-lifting equipment must attach to the pavement.

Instead of disposing of removed concrete pavement by removing it from the job site, you may dispose of it under section 15-3.01.

15-2.02B(5)(b) Saw Cuts

Saw cut using a diamond blade and make cuts perpendicular to the pavement surface. Saw cutting is not required where concrete pavement is adjacent to asphalt concrete pavement.

Saw cut (1) no more than 2 days before removing pavement and (2) such that traffic will not dislodge any pavement piece or segment. Saw cut perpendicular to the traveled way except you may cut parallel or diagonal to the traveled way when removing the pavement during the same lane closure as the saw cutting.

You may make additional saw cuts within the sawed outline.

Saw cuts must be the full depth of the pavement unless otherwise shown.

Saw cut at longitudinal and transverse joints to remove entire slabs. For partial-slab areas, the Engineer determines the exact saw-cut locations.

15-2.02B(5)(c) Reserved

15-2.02B(6) Reserved

15-2.02B(7) Payment

Reserved

Replace section 15-2.02G with:

07-19-13

15-2.02G Remove Guardrail

Where removing guardrail, remove any concrete anchors and steel foundation tubes.

Replace the 1st paragraph of section 15-2.02K with:

07-19-13

Box culverts, concrete pipes, inlets, headwalls, and endwalls must be completely removed if any portion of these structures is (1) within 3 feet of the grading plane in excavation areas, (2) within 1 foot of original ground in embankment areas, or (3) shown to be removed.

Replace "Metal beam guard railing" in the table in the 2nd paragraph of section 15-2.03A(2)(a) with:

07-19-13

Guardrail

Replace the heading of section 15-2.03B with:

07-19-13

Salvage Guardrail

Replace the heading of section 15-2.04D with:

07-19-13

Reconstruct Guardrail

Replace section 15-2.09D with:

07-19-13

15-2.09D Reserved

Replace the 4th paragraph of section 15-2.10B with:

01-18-13

Instead of using new materials similar in character to those in the existing structure, you may use raising devices to adjust a manhole to grade. Before starting paving work, measure and fabricate raising devices. Raising devices must:

1. Comply with the specifications for section 75 except that galvanizing is not required
2. Have a shape and size that matches the existing frame
3. Be match marked by painting identification numbers on the device and corresponding structure
4. Result in an installation that is equal to or better than the existing one in stability, support, and nonrocking characteristics
5. Be fastened securely to the existing frame without projections above the surface of the road or into the clear opening

Replace the heading of section 15-2.10D with:

07-19-13

Adjust Guardrail

Replace the paragraphs of section 15-3.01 with:

07-19-13

Section 15-3 includes specifications for removing all or a portion of a concrete facility.

Concrete facilities include curbs, gutters, gutter depressions, sidewalks, driveways, slope paving, island paving, barriers, retaining walls, sound walls, minor structures, aprons, spillways, and dams.

Where broken-concrete slope protection is shown, use removed concrete for the construction of the broken-concrete slope protection.

Instead of disposing of removed concrete by removing it from the job site, you may dispose of it on the job site by one of the following methods:

1. Burying it in embankments at authorized locations. Removed concrete must be broken into pieces that can be readily handled and incorporated into embankments and placed at a depth of at least 3

feet below finished grade and slope lines. Concrete must not be buried in areas where piling is to be placed or within 10 feet of trees, pipelines, poles, buildings or other permanent objects or structures.

2. Placing it at authorized locations. The removed concrete must not present an unsightly appearance from the highway.

Replace the paragraph of section 15-3.02 with:

07-19-13

Not Used

07-19-13

Delete the 5th paragraph of section 15-3.03.

Add to the end of section 15-4.01A(2):

04-19-13

Allow 20 days for review of the bridge removal work plan.

Replace the 2nd sentence of the 3rd paragraph of section 15-4.02C(1) with:

10-17-14

Paint exposed ends of the remaining reinforcement with 2 applications of organic zinc-rich primer as specified for painting exposed ends of prestressing steel in section 50-1.03B(3).

Replace the 1st paragraph of section 15-5.01C(1) with:

10-19-12

Before starting deck rehabilitation activities, complete the removal of any traffic stripes, pavement markings, and pavement markers.

Replace the 2nd and 3rd paragraphs of section 15-5.01C(2) with:

10-19-12

Perform the following activities in the order listed:

1. Abrasive blast the deck surface with steel shot. Perform abrasive blasting after the removal of any unsound concrete and placement of any rapid setting concrete patches.
2. Sweep the deck surface.
3. Blow the deck surface clean using high-pressure air.

Replace the 2nd paragraph of section 15-5.01C(4) with:

10-19-12

Before removing asphalt concrete surfacing, verify the depth of the surfacing at the supports and midspans of each structure (1) in each shoulder, (2) in the traveled way, and (3) at the roadway crown, if a crown is present.

04-19-13

Delete "and concrete expansion dams" in the 3rd paragraph of section 15-5.01C(4).

Replace the 2nd paragraph of section 15-5.03A(2) with:

10-19-12

For a contract with less than 60 original working days, submit certificates of compliance for the filler material and bonding agents.

Replace "51-1.02C" in the 1st paragraph of section 15-5.03B with:

04-19-13

51-1.02F

Replace the 4th paragraph of section 15-5.03B with:

10-19-12

For a contract with less than 60 original working days, alternative materials must be authorized before use.

Add between the 5th and 6th paragraphs of section 15-5.03C:

10-19-12

The final surface finish of the patched concrete surface must comply with section 51-1.03F.

Delete the 4th paragraph of section 15-5.05C.

10-19-12

Replace "51-1.03F(5)" in the 3rd paragraph of section 15-5.06C(1) with:

07-19-13

51-1.01D(4)(b)

Replace "51-1.03E(5)" in the 5th paragraph of section 15-5.06C(1) with:

10-19-12

51-1.03F(5)

10-19-12

Delete the 9th paragraph of section 15-5.06C(1).

04-19-13

Delete the 15th paragraph of section 15-5.06C(1).

Add between the 18th and 19th paragraphs of section 15-5.06C(1):

07-19-13

Texture the polyester concrete surface before gelling occurs by longitudinal tining under 51-1.03F(5)(b)(iii), except do not perform initial texturing.

Replace section 15-5.06C(2) with:

04-19-13

15-5.06C(2) Reserved

04-19-13

Delete the 3rd paragraph of section 15-5.06D.

Replace the 1st paragraph in section 15-5.07B(4) with:

10-19-12

Payment for furnishing dowels is not included in the payment for core and pressure grout dowel.

Replace section 15-5.09 with:

04-19-13

15-5.09 POLYESTER CONCRETE EXPANSION DAMS

15-5.09A General

Section 15-5.09 includes specifications for constructing polyester concrete expansion dams.

Polyester concrete expansion dams must comply with the specifications for polyester concrete overlays in section 15-5.06, except a trial slab is not required.

Reinforcement must comply with section 52.

15-5.09B Materials

Not Used

15-5.09C Construction

For new asphalt concrete overlays, place the asphalt concrete overlay before starting polyester concrete activities. Saw cut and remove asphalt concrete at expansion dam locations.

For existing asphalt concrete overlays, remove expansion dams and asphalt concrete to the limits shown. Removing expansion dams must comply with section 15-4 except a bridge removal work plan is not required.

Where a portion of the asphalt concrete overlay is to remain, saw cut a 2-inch-deep neat line along the edge to remain in place before removing the asphalt concrete. Do not damage the existing surfacing to remain in place.

Prepare the deck surface under section 15-5.01C(2).

You may use a mechanical mixer to mix the polyester concrete for expansion dams. The mixer capacity must not exceed 9 cu ft unless authorized. Initiate the resin and thoroughly blend it immediately before mixing it with the aggregate. Mix the polyester concrete for at least 2 minutes before placing.

The application rate of methacrylate resin must be approximately 100 sq ft/gal.

You may place and finish expansion dams using hand methods.

Replace "20-1.03D" in the 2nd paragraph of section 16-1.03B with:

07-19-13

20-3.01C(2)

^^

18 DUST PALLIATIVE

05-30-14

Replace section 18 with:

05-30-14

18 DUST PALLIATIVES

18-1.01 GENERAL

18-1.01A Summary

Section 18 includes specifications for applying dust palliatives.

The dust palliative must be any of the following:

- 1. Water
- 2. Dust suppressant
- 3. Dust control binder

Water must comply with section 17.

18-1.01B Definitions

Reserved

18-1.01C Submittals

If a dust suppressant or dust control binder is to be used, submit a dust treatment plan at least 15 days before starting job site activities. The dust treatment plan must include:

- 1. Product name and type
- 2. Manufacturer's name
- 3. Polymer emulsion type if synthetic polymer emulsion is used, including identification of:
 - 3.1. Individual components greater than 5 percent by volume in blends of polymers of different compositions
 - 3.2. Additives greater than 2 by volume
- 4. MSDS
- 5. Proposed methods for applying products
- 6. Application rates and number of passes
- 7. Required weather conditions for application, including ambient and surface temperatures, wind conditions, and allowable period before expected precipitation
- 8. Drying time or curing time required before traffic is allowed on the treated surface

Submit the manufacturer's instructions for the material to be used as an informational submittal.

Submit a certificate of compliance for the dust suppressant, dust control binders, and fibers.

For dust suppressants, include with the certificate of compliance:

1. Test results verifying compliance with the quality characteristic requirements in section 18-1.01D. The results must be from a test conducted within 6 months before the date of the certificate of compliance.
2. Test results from a test conducted within 2 years before the date of the certificate of compliance verifying compliance with the following environmental requirements:
 - 2.1. Maximum constituent concentration levels
 - 2.2. US EPA regulatory requirements for:
 - 2.2.1. Volatile organic compounds
 - 2.2.2. Semivolatile organic compounds
 - 2.2.3. Toxicity characteristic leaching
 - 2.2.3. Modified synthetic leaching procedure
 - 2.3. Aquatic toxicity

18-1.01D Quality Control and Assurance

Dust palliatives must comply with US EPA requirements and RWQCB requirements for soil stabilizers.

Dust suppressants must be tested by an EPA-accredited laboratory. Liquid chemical treatments must be tested before dilution. Solid products must be mixed with water to a 25 percent concentration before testing. The chemical constituent concentration for each dust suppressant must not exceed the maximum levels shown in the following table:

Maximum Constituent Concentration Levels

Constituent	Test method	Requirement maximum level (ppm)
Arsenic	EPA Method 200.7	5.0
Barium		100.0
Cadmium		0.2
Chromium		1.0
Copper		1.0
Lead		1.0
Mercury	EPA Method 245.1	0.05
Selenium	EPA Method 200.7	5.0
Zinc		10.0
Phosphorus	EPA Method 365.4	2500.0
Cyanide	EPA Method 335.4	0.2

Dust suppressants must comply with the US EPA requirements for the quality characteristics when tested under the test methods shown in the following table:

Quality characteristic	Test method
Volatile organic compounds (VOC)	EPA Method 8260
Semivolatile organic compounds (SVOC)	EPA Method 8270
Toxicity characteristic leaching procedure	EPA Method 1311
Modified synthetic leaching procedure	EPA Method 1312

The aquatic toxicity for dust suppressant must comply with the requirements shown in the following table:

Aquatic Toxicity Requirements

Quality characteristic	Test method	Requirement
Aquatic toxicity ^a (LC50 min, ppm)	ASTM E729 or EPA Method 600/4-90/027F and EPA Method 600/4-91/002	10
Aquatic toxicity ^a (rating)	ASTM E729 or EPA Method 600/4-90/027F and EPA Method 600/4-91/002	slightly toxic or better
Renewal toxicity ^b (LC50 min, ppm)	ASTM E1295	10
Renewal toxicity ^b (rating)	ASTM E1295	slightly toxic or better

^aUsing *Ceriodaphnia dubia* (water flea), *Oncorhynchus mykiss* (rainbow trout), *Pimephales promelas* (fathead minnow), and *Americamysis bahia* (mysid shrimp)

^bUsing *Ceriodaphnia dubia* (water flea)

18-1.02 MATERIALS

18-1.02A General

Dust suppressants and control binders must be either (1) miscible in water or (2) a material that is directly applied to the surface without mixing with water.

18-1.02B Dust Suppressants

18-1.02B(1) General

Dust suppressants must be one of the following:

1. Petroleum-based organic product
2. Nonpetroleum-based organic product
3. Hygroscopic product
4. Synthetic polymer emulsions

18-1.02B(2) Petroleum-Based Organic Products

Petroleum-based organic dust suppressants must be asphalt emulsion, petroleum resin, base oil, mineral oil, or synthetic fluid.

Asphalt emulsion must be Grade SS1h.

Petroleum resin must comply with the requirements shown in the following table:

Petroleum Resin Requirements

Quality characteristic	Test method	Requirement
Residue (min, %)	ASTM D6934	60
pH	ASTM D1429	4.0–7.0
Specific gravity at 16 °C (min)	ASTM D1298	1.00
Kinematic viscosity at 25 °C (min, Saybolt Furol seconds ^a)	ASTM D2170	188
Flash point (min °C)	ASTM D92	205
Particle charge test	ASTM D7402	Positive

^a Use ASTM D2161 to convert the mm²/s value to Saybolt Furol seconds

Base and mineral oils must comply with the requirements shown in the following table:

Base and Mineral Oils Requirements

Quality characteristic	Test method	Requirement
Base and mineral oil content (min, %)	-	75
Specific gravity at 16 °C (min)	ASTM D1298	0.85–0.90
Brookfield absolute viscosity at 68 °C (max, cP)	ASTM D2196	250
Flash point (min, °C)	ASTM D93	150

Synthetic fluids must comply with 40 CFR 35 and the requirements shown in the following table:

Synthetic Fluids Requirements

Quality characteristic	Test method	Requirement
Base and mineral oil content (min, %)	--	75
Specific gravity at 16 °C (min)	ASTM D1298	0.85–0.90
Brookfield absolute viscosity at 68 °C (max, cP)	ASTM D2196	250
Flash point (min, °C)	ASTM D93	150

18-1.02B(3) Nonpetroleum-Based Organic Products

Nonpetroleum-based organic dust suppressants must be lignosulfonate, plant oil, or tall oil pitch rosin.

Lignosulfonate must comply with the requirements shown in the following table:

Lignosulfonate Requirements

Quality characteristic	Test method	Requirement
Lignin sulfonate content ready to use (min, %)	ASTM D4900	25
Residue total solids content (min %)	ASTM D4903 or D2834	52
Lignin sulfonate content of residue (min, %)	--	50
Reducing sugars content of residue (min, %)	ASTM D5896 or D6406	25
pH	ASTM D1293	6.0–9.0
Specific gravity (min)	ASTM D1429	1.20
Brookfield absolute viscosity at 25° C (max, cP)	ASTM D2196	1,000

Plant oil must comply with the requirements shown in the following table:

Plant Oil Requirements

Quality characteristic	Test method	Requirement
Residue active solids content (min, %)	ASTM D4903	50
Specific gravity (min)	ASTM D1429	0.93
Brookfield viscosity (cP)	ASTM D2196	48

Tall oil pitch rosin must comply with the requirements shown in the following table:

Tall Oil Pitch Rosin Requirements

Quality characteristic	Test method	Requirement
Rosin acid content (min, %)	ASTM D1240	10
Residue active solids content (min, %)	ASTM D2834	45
pH	ASTM D1293	3.0–9.0
Specific gravity (min)	ASTM D1429	1.00
Brookfield absolute viscosity at 25 °C (cP)	ASTM D2196	50–200

18-1.02B(4) Hygroscopic Products

Hygroscopic dust suppressants must be calcium chloride, calcium chloride flake, or magnesium chloride.

Calcium chloride must comply with the requirements shown in the following table:

Calcium Chloride^a Requirements

Quality characteristic	Test method	Requirement
Calcium chloride content (%)	ASTM E449	28–42
Total magnesium as MgCl ₂ (max, %)	ASTM E449	6.0
Total alkali chlorides as NaCl (max, %)	ASTM E449	6.0
Calcium hydroxide content (max, %)	ASTM E449	0.2
pH with 5 percent solution	ASTM D1293	7.0–9.0
Specific gravity	ASTM D1429	1.28–1.44

^aASTM D98 or AASHTO M144

Calcium chloride flake must comply with the requirements shown in the following table:

Calcium Chloride Flake^a Requirements

Quality characteristic	Test method	Requirement
Calcium chloride content (%)	ASTM E449	28–42
Total magnesium as MgCl ₂ (max, %)	ASTM E449	6.0
Total alkali chlorides as NaCl (max, %)	ASTM E449	6.0
Calcium hydroxide content (max, %)	ASTM E449	0.2
pH with 5 percent solution	ASTM D1293	7.0–9.0
Gradation percent passing	ASTM C136	
3/8–inch sieve		100
#4 sieve		80–100
#30 sieve		0–5

^aASTM D98 or AASHTO M144

Magnesium chloride must comply with the requirements shown in the following table:

Magnesium Chloride Requirements

Quality characteristic	Test method	Requirement
Magnesium chloride content (%)	ASTM D4691 or ASTM D511 ^a	28–33
Sulfate content as magnesium sulfate (max, %)	ASTM D4691 ^a	4.0
Potassium content as potassium chloride (max, %)	ASTM E449	0.5
Sodium chloride content (max, %)	ASTM E449	1.0
pH with 5% solution	ASTM D1293	7.0–9.0
Specific gravity	ASTM D1429	1.31 ± 0.02

^aYou may use another appropriate atomic absorption spectrophotometry method such as that in *Standard Methods for the Examination of Water and Waste Water* by APHA-AWWA-WPCF.

18-1.02B(5) Synthetic Polymer Emulsions

Synthetic polymer emulsions must comply with the requirements shown in the following table:

Synthetic Polymer Emulsion Requirements

Quality characteristic	Test method	Requirement
Residue active solids content (min, %)	ASTM D2834	40
pH	ASTM D1429	4.0–9.5
Specific gravity at 16 °C	ASTM D1298	1.00–1.15
Brookfield absolute viscosity (max, cP)	ASTM D2196	1,000
Polymer film tensile strength – dry (psi)	ASTM D412	500
Retained coagulum on #100 sieve (max, %)	ASTM D1417	0.1
Ash content (max, %)	ASTM D5040	2

18-1.02C Dust Control Binders

Dust control binders must comply with the specifications for a general purpose tackifier in section 21-1.02F(1).

Fibers must comply with section 21-1.02E.

18-1.03 CONSTRUCTION

18-1.03A General

Monitor dust conditions and apply dust palliative for dust control as described and as ordered. Reapply dust palliative at any time to control dust.

Apply a dust suppressant to:

1. Temporary haul roads
2. Construction staging, material storage, and layout areas
3. Compacted soil or aggregate base roads or driveways
4. Paved surfaces

Apply a dust control binder to:

1. Rough-graded soils
2. Completed slopes
3. Soil stockpiles unless another practice is already used

Do not use a dust suppressant or dust control binder within 100 feet of a wetland or body of water.

18-1.03B Equipment

Apply dust suppressants that are miscible in water with either (1) a pressure-type water distributor truck equipped with a spray system or (2) a pressure-type asphalt distributor truck as specified in section 93-1.03C.

Apply dust suppressant flakes to the surface using a spreader or spinner disk.

Apply dust control binders with either (1) a pressure-type water distributor truck equipped with a spray system or (2) hydraulic spray equipment as specified for applying hydromulch in section 21-1.03E.

18-1.03C Mixing and Application Rates

Use the mix proportions and application rate for the corresponding dust suppressant as shown in the following table:

Dust suppressant	Mix proportions	Application rate
Asphaltic emulsion, Grade SS1H	5 parts water to 1 part emulsion	0.20–1.0 gal/sq yd
Petroleum resin emulsion	5 parts water to 1 part emulsion	0.20–1.0 gal/sq yd
Base and mineral oil	Apply undiluted	0.30–0.35 gal/sy yd
Lignosulfonate	1 part water to 1 part concentrate	1.0 gal/sq yd
Plant oil	Apply undiluted	0.25–0.50 gal/sq yd
Tall oil pitch rosin	5 parts water to 1 part emulsion for clayey soil and 10 parts water to 1 part emulsion for sandy soil.	0.30–1.0 gal/sq yd
Calcium chloride solution (Hygroscopic)	Apply undiluted	0.20–0.35 gal/sq yd
Calcium chloride flakes (Hygroscopic)	--	1.0–1.5 lb/sq yd
Magnesium chloride (Hygroscopic)	Apply undiluted	0.30–0.50 gal/sq yd
Synthetic polymer emulsion	9 parts water to 1 part concentrate	0.50 gal/sq yd

Apply hygroscopic materials under the manufacturer's instructions.

Apply calcium chloride flakes to a moist surface.

Allow surfaces treated with a dust suppressant to cure before opening to traffic.

Use the mix proportions and application rate for the corresponding dust control binder as shown in the following table:

Dust control binder	Mix proportions	Application rate
Guar	11 to 15 pounds per 1,000 gallons of water	44–59 lb/acre
Psyllium	Enough water to allow for uniform slurry flow	80–200 lb/acre
Starch	Manufacturer's recommended mix proportions with water	150 lb/acre
Liquid acrylic copolymers and polymers ^a	10 parts water to 1 part polymer	1,175 gal/acre
Liquid methacrylate and acrylate polymers	Manufacturer's recommended mix proportions with water	20 gal/acre
Copolymers of sodium acrylates and acrylamides	Manufacturer's recommended mix proportions with water	3–10 lb/acre
Polyacrylamide and copolymer of acrylamide	10 pounds per 1,000 gallons of water	5 lb/acre
Hydro-colloid polymers	Manufacturer's recommended mix proportions with water	54–64 lb/acre

^aMix and handle the polymeric compound in a manner that will not cause foaming. You may add an antifoaming agent.

Do not allow stormwater runoff from polyacrylamide treated soils unless water passes through:

1. Sediment basin if the total drainage area is greater than or equal to 5 acres.
2. Sediment trap or a series of check dams if the total drainage area is less than 5 acres. Maximize the number of check dams used and space them evenly in the drainage channel so as to maximize sediment settlement.

You may add fibers to dust control binders at a rate of 2,000 lb/acre.

You may use reduced application rates when reapplying dust palliatives if authorized.

18-1.04 PAYMENT

Not Used

^^

19 EARTHWORK

10-17-14

Replace "20-3.03B(4)" in the 2nd paragraph of section 19-1.01A with:

07-19-13

20-2.02C(2)

Replace the 3rd paragraph in section 19-2.01A with:

07-19-13

Pavement removal within the limits of roadway excavation must comply with section 15-2.02B.

07-19-13

Delete the 2nd paragraph in section 19-2.03A.

Add to the 2nd paragraph of section 19-2.03D:

10-17-14

Topsoil must comply with section 21.

Replace the 2nd paragraph of section 19-3.01A(2)(b) with:

07-01-11

For cofferdams on or affecting railroad property, allow 85 days for review.

Add to the list in the 1st paragraph of section 19-3.01A(2)(d):

01-20-12

9. Provisions for discontinuous rows of soil nails

Replace "sets" in the 3rd and 4th paragraphs of section 19-3.01A(2)(d) with:

04-19-13

copies

Add to section 19-3.01A(3)(b):

01-20-12

For soil nail walls, wall zones are specified in the special provisions.

For ground anchor walls, a wall zone is the entire wall unless otherwise specified in the special provisions.

01-20-12

Delete the 2nd sentence in the 4th paragraph of section 19-3.01A(3)(b).

Replace "90" in the paragraph of section 19-3.02G with:

01-18-13

90-1

Add to section 19-3.02:

07-19-13

19-3.02I Filter Fabric

Filter fabric must be Class A.

Replace the heading of section 19-3.03C with:

04-19-13

19-3.03B(4) Cofferdams

Replace the heading of section 19-3.03D with:

04-19-13

19-3.03B(5) Water Control and Foundation Treatment

Replace the 1st paragraph of section 19-3.03E(3) with:

01-20-12

Compact structure backfill behind lagging of soldier pile walls by hand tamping, mechanical compaction, or other authorized means.

Add to the end of section 19-3.03E(3):

07-19-13

If filter fabric is shown behind the lagging:

1. Immediately before placing the filter fabric, remove any loose or extraneous material and sharp objects from the surface to receive the filter fabric.
2. Handle and place the filter fabric under the manufacturer's instructions. Stretch, align, and place the fabric without wrinkling.
3. Stitch the adjacent borders of filter fabric or overlap the adjacent borders by 12 to 18 inches. If stitching the border, use yarn of a contrasting color. Yarn size and composition must be as recommended by the fabric manufacturer. Use 5 to 7 stitches per inch of seam.
4. Repair any damaged filter fabric by placing a piece of filter fabric large enough to cover the damaged area and comply with the overlapping or stitching requirements.

Replace the 2nd paragraph of section 19-3.03F with:

01-20-12

Do not backfill over or place material over slurry cement backfill until 4 hours after placement. When concrete sand is used as aggregate and the in-place material is free draining, you may start backfilling as soon as the surface water is gone.

Add between the 2nd and 3rd paragraphs of section 19-3.03K:

01-20-12

Before you excavate for the installation of ground anchors in a wall zone:

1. Complete stability testing
2. Obtain authorization of test data

Replace the 2nd sentence of the 7th paragraph of section 19-3.03K:

01-20-12

Stop construction in unstable areas until remedial measures have been taken. Remedial measures must be submitted and authorized.

Add between the 8th and 9th paragraphs of section 19-3.03K:

01-20-12

When your excavation and installation methods result in a discontinuous wall along any soil nail row, the ends of the structurally completed wall section must extend beyond the ends of the next lower excavation lift by a distance equal to twice the lift height. Maintain temporary slopes at the ends of each wall section to ensure slope stability.

Replace the 9th paragraph of section 19-3.03K:

01-20-12

Do not excavate to the next underlying excavation lift until the following conditions have been attained for the portion of the soil nail or ground anchor wall in the current excavation lift:

1. Soil nails or ground anchors are installed and grouted.
2. Reinforced shotcrete facing is constructed.
3. Grout and shotcrete have cured for at least 72 hours.
4. Specified tests are complete for that portion of wall and the results are authorized.
5. Soil nail facing anchorages are attached or ground anchors are locked off.

01-18-13

01-20-12

Replace the 2nd sentence in the 7th paragraph of section 19-3.04 with:

01-18-13

Structure excavation more than 0.5 foot from the depth shown is paid for as a work-character change if you request an adjustment or the Engineer orders an adjustment.

Replace "Contract completion time" in the 8th paragraph of section 19-6.03D with:

10-19-12

work completion date

Add to section 19:

01-18-13

19-10-19-20 RESERVED

^^

20 LANDSCAPE

05-30-14

Replace the headings and paragraphs in section 20 with:

07-19-13

20-1 GENERAL

20-1.01 GENERAL

20-1.01A Summary

Section 20-1 includes general specifications for performing landscaping.

If an irrigation system is to be installed in an existing planting area to be maintained, check for plant deficiencies under section 20-3.02A(4) before starting irrigation work.

Perform a functional test for each irrigation system under 20-2.01A(4)(d):

- 1. Before planting the plants
- 2. After planting the plants
- 3. Before the start of the plant establishment work

If a plant is to be transplanted or an irrigation component is to be relocated, transplant plant or protect irrigation components before performing other construction activities in the area.

Perform roadside clearing:

- 1. As required to prepare the job site for construction work
- 2. Until the start of the plant establishment work or Contract acceptance, whichever comes first

20-1.01B Definitions

Reserved

20-1.01C Submittals

At least 15 days before applying any pesticide, submit a copy of the licensed pest control adviser's recommendation.

At the end of each week, submit a report documenting the application of all pesticides as an informational submittal. Use form *Report of Chemical Spray Operations*.

Before mixing a pesticide, submit a copy of the registered label for the pesticide as an informational submittal. If unable to copy, allow the Engineer to read the label on the container.

20-1.01D Quality Control and Assurance

20-1.01D(1) General

Obtain a recommendation from a licensed pest control adviser for the use of all pesticides under the Food & Agri Code. The recommendation must include the pesticides to be used, rates of application, methods of application, and application areas.

The pesticide applicator must have an active and valid qualified applicator license or certificate from the Department of Pesticide Regulation.

20-1.01D(2) Progress Inspections

The Engineer will perform progress inspections before:

1. Cultivating work starts
2. Pressure testing of irrigation pipe on the supply side of control valves
3. Testing of low voltage conductors
4. Planting work starts
5. Completion of planting work

Notify the Engineer at least 4 business days before each inspection is required. Allow at least 3 business days for the Engineer's inspection.

Unless otherwise authorized, do not proceed with the next construction activity until the inspection has been completed and any required corrective work has been performed and authorized.

20-1.02 MATERIALS

20-1.02A General

Reserved

20-1.02B Water

Water available from an existing Department-owned facility within the project limits or an irrigation system to be installed under the Contract is furnished at no charge.

If water is not available, make arrangements for supplying water. Water must be of a quality that will promote plant growth.

20-1.02C Pesticides

Pesticides must comply with the Department of Pesticide Regulation.

Insecticide must be imidacloprid.

Rodenticides must be brodifacoum, bromadiolone, or diphacinone.

Do not use oil or pelleted forms of pesticides for weed control.

For weed control, use a pesticide with a photosensitive dye that produces a contrasting color when sprayed on the ground. The color must disappear between 2 to 3 days after being applied. The dye must not stain surfaces or injure plants or wildlife when applied at the manufacturer's recommended application rate.

20-1.03 CONSTRUCTION

20-1.03A General

Take precautions to prevent irrigation water from:

1. Wetting vehicles, pedestrians, and pavement

2. Eroding soil

05-30-14

3. Causing excess runoff

Water plants under the Model Water Efficient Landscape Ordinance, 23 CA Code of Regs § 490 et seq., and local water agency requirements.

Water plants at night unless otherwise authorized.

07-19-13

Dispose of removed, pruned, and damaged vegetative material.

You may reduce removed vegetative material to chips with a maximum thickness of 1/2 inch and spread within the job site at locations determined by the Engineer. Chipped material must not be substituted for wood mulch, nor must the chipped material be placed within areas to receive wood mulch.

20-1.03B Pesticides

Notify the Engineer of pesticide application times at least 24 hours before each application.

Mix and apply pesticides under the requirements of the Department of Pesticide Regulation and the instructions on the pesticide product label.

Do not apply pesticides:

1. On Saturdays and holidays unless authorized
2. Whenever weather and wind conditions are unsuitable for application
3. Within the plant basin
4. On the foliage and woody parts of the plant

If a granular preemergent is used, it must be covered with mulch on the same work day. Do not apply granular preemergent in plant basins.

Do not apply preemergents:

1. To groundcover plants before the plants have been planted a minimum of 3 days and have been thoroughly watered
2. Within 18 inches of trees, shrubs, and seeded areas

20-1.03C Roadside Clearing

20-1.03C(1) General

Perform roadside clearing by:

1. Removing and disposing of trash and debris
2. Controlling the following pests:
 - 2.1. Rodents
 - 2.2. Insects
 - 2.3. Weeds
3. Removing existing plants as described

Control rodents by using rodenticides or traps.

20-1.03C(2) Remove Existing Plants

Remove existing plants as described. Removal of existing plants includes removing their stumps and roots 2 inches or larger in diameter to a minimum depth of 12 inches below finished grade. Backfill holes resulting from stump removal to finished grade with material obtained from adjacent areas.

If a plant is to be planted within existing groundcover area, remove existing groundcover from within an area 6 feet in diameter centered at each plant location.

20-1.03C(3) Weed Control

Control weeds by the use of pesticides, hand pulling, or mowing.

If pesticides are used to control weeds, apply pesticides before the weeds reach the seed stage of growth or exceed 4 inches in length, whichever occurs first. Do not use pesticides at cutting plant locations.

Where cuttings are to be planted, control weeds by hand pulling within an area 2 feet in diameter centered at each plant location.

If weeds are to be controlled by hand pulling, hand pull weeds before they reach the seed stage of growth or exceed 4 inches in length, whichever occurs first.

Where liner, plug, or seedling plants are to be planted 10 feet or more apart, control weeds by the use of pesticides or hand pulling within an area 2 feet in diameter centered at each plant location. Where liner, plug, or seedling plants are to be planted less than 10 feet apart, control weeds by the use of pesticides within the entire area.

Control weeds by mowing outside of mulched areas, plant basins, groundcover areas, and within areas to be seeded. Mowing must extend to the edges of pavement, dikes, curbs, sidewalks, walls, and fences.

If mowing is to be performed within areas to be seeded, perform mowing as needed until the start of the seeding operation specified in section 21.

Mowing must be performed before the weeds reach the seed stage of growth or exceed 6 inches in length, whichever occurs first. Mow weeds to a height of 3 inches.

20-1.03C(4) Disposal of Removed Groundcover, Weeds, and Mowed Material

Dispose of hand pulled weeds the same day they are pulled. Dispose of removed groundcover within 3 days.

Dispose of mowed material from the initial mowing. Disposal of material from subsequent mowing is not required.

20-1.03D Cultivation

Cultivation must be by mechanical methods and performed until the soil is in a loose condition to a minimum depth of 6 inches. Soil clods must not be larger than 2 inches in maximum dimension after cultivation.

The areas to be cultivated must extend 12 inches beyond the outer limit of each planting area requiring cultivation.

After initial cultivation, place soil amendment and fertilizer at specified rates.

Recultivate to thoroughly mix native soil and amendments.

Do not drive on cultivated areas after cultivation.

Planting areas that have been cultivated and become compacted must be recultivated.

Rocks and debris encountered during soil preparation in planting areas must be brought to the surface of the ground.

Remove rocks and debris as ordered. This work is change order work.

20-1.03E Weed Germination

Reserved

20-1.04 PAYMENT

Items paid for by area are measured parallel to the ground surface.

Planting areas that do not require cultivation but are within the cultivation areas will not be deducted.

20-2 IRRIGATION

20-2.01 GENERAL

20-2.01A General

20-2.01A(1) Summary

Section 20-2 includes specifications for installing irrigation systems.

The irrigation systems shown are diagrammatic.

20-2.01A(2) Definitions

Reserved

20-2.01A(3) Submittals

20-2.01A(3)(a) General

Submit shop drawings for the electrical components of the irrigation system except electrical service 30 days before installation. The drawings must:

1. Include schematic wiring diagrams showing wire sizes and routes between electrical components
2. Show conduit sizes
3. Bear the written approval of the controller manufacturer or the manufacturer's authorized agent
4. Be accompanied by:
 - 4.1. Colored wire and splice samples
 - 4.2. Manufacturer's descriptive and technical literature

After the work shown on the drawing is complete, submit 3 copies of the as-built shop drawings including any wire modifications for each controller installed.

For each controller, laminate and place in an envelope 1 copy of:

1. As-built schematic wiring diagram including wiring modifications
2. 11 by 17 inches as-built irrigation plan

The laminate must be clear, mat-finished plastic that is at least 10 mils thick. The envelope must be heavy-duty plastic.

Attach the envelope to the inside of the controller enclosure or cabinet door. If the door is not large enough to secure the envelope, submit the envelope and its contents.

20-2.01A(3)(b) Manufacturer's Instructions

Submit as an informational submittal the manufacturer's installation instructions 15 days before installing:

1. Couplings for conduits used for irrigation conduits
2. Plastic pipe and fittings

3. Solvent cement for plastic pipe and flexible hose
4. Sprinklers
5. Flow sensors

20-2.01A(3)(c) Maintenance and Operation Manuals

Before Contract acceptance, submit as an informational submittal a manufacturer's maintenance and operation manual for each type of controller installed.

20-2.01A(4) Quality Control and Assurance

20-2.01A(4)(a) General

Reserved

20-2.01A(4)(b) Pressure Testing

20-2.01A(4)(b)(i) General

Perform pressure testing for leakage on irrigation supply lines:

1. In the Engineer's presence
2. On business days between 8 a.m. and 5 p.m. unless authorized
3. Before backfilling supply line trenches
4. With irrigation system gate valves open
5. With open ends of the supply line and fittings plugged or capped

Notify the Engineer at least 48 hours before performing a pressure test.

Choose either Method A or B to test supply lines installed by trenching and backfilling and supply lines that are completely visible after installation.

All other supply lines, including those installed in the ground by methods other than trenching and backfilling must be tested by Method A.

Test irrigation supply line in conduit by Method A with the testing period modified to 0.5 hour and no allowable pressure drop.

20-2.01A(4)(b)(ii) Method A

Method A pressure testing procedures for leakage must comply with the following:

1. Pressure gauge must be calibrated from 0 to 200 psi in 5 psi increments and be accurate to within a tolerance of 2 psi.
2. Supply line must be filled with water and connected to a pressure gauge. Place the pipeline under a pressure of 125 psi. Remove the source of pressure and leave the line under the required pressure.
3. Test the supply line under the required pressure for a period of 1 hour. The pressure gauge must remain in place until each test period is complete.
4. Leaks that develop in the tested portion of the system must be located and repaired after each test period if a drop of more than 5 psi is indicated by the pressure gauge. After the leaks have been repaired, repeat the 1 hour pressure test until the drop in pressure is 5 psi or less.

If a system consists of a new supply line connected to an existing line, the new supply line must be isolated from the existing line and tested.

20-2.01A(4)(b)(iii) Method B

Method B pressure testing procedures for leakage must comply with the following:

1. Before any portion of the supply line on the upstream side of a control valve is backfilled, water must be turned on for that portion of the line and maintained at full pressure from the water source for a period not less than 8 consecutive hours after all air has been expelled from the line. Before any portion of the supply line on the downstream side of the control valve is backfilled, perform the same test for a period not less than 1 hour.
2. Repair leaks that develop in the tested portion of the system. After the leaks have been repaired, repeat the pressure test until no leaks occur as determined by the Engineer.

20-2.01A(4)(c) Sprinkler Coverage Check

After installation of the sprinklers, check and adjust the entire sprinkler system for proper orientation and uniform coverage.

20-2.01A(4)(d) Irrigation System Functional Tests

The functional tests for each irrigation controller or group of controllers and associated irrigation system served by a single electric service point must consist of at least 1 complete cycle of operation. The Engineer determines the length of the cycle.

Notify the Engineer at least 10 days before performing each functional test.

20-2.01A(4)(e) Final Irrigation System Check

Perform the final check of the existing and new irrigation system between 20 and 30 days before Contract acceptance. The Engineer determines the length of the cycle.

Remote control valves connected to existing and new irrigation controllers must be checked for automatic operation when the controllers are in automatic mode.

20-2.01B Materials

20-2.01B(1) General

Use minor concrete for replacing removed concrete facilities.

HMA for replacing removed asphalt concrete surfacing and facilities must comply with section 39. You may use minor HMA if authorized.

20-2.01B(2) Garden Valves

Each garden valve must:

1. Be inverted nose type and of brass or bronze construction with female thread inlet
2. Have a replaceable seat washer, rising valve stem within a protective collar, and male thread hose outlet
3. Have a loose key handle

20-2.01B(3) Recycled Water Identification

Irrigation components used for recycled water must be manufactured or painted purple. Recycled water irrigation pipe and tubing must have a permanent label with the wording "CAUTION RECYCLED WATER" every 24 inches in 2 rows spaced approximately 180 degrees apart in the longitudinal direction of the pipe or tubing.

The recycled water warning sign must be a decal or a decal attached to a 1/16-inch thick aluminum plate or tag.

Each warning sign decal must:

1. Show the phrase "Recycled Water, Do Not Drink" and the drinking glass graphic symbol
2. Be UV fade and weather resistant and manufactured from flexible vinyl with or without mylar
3. Have a purple background, black text, and self-adhesive backing

Each warning tag must:

1. Show the phrase "RECYCLED WATER" and the drinking glass graphic symbol
2. Be UV fade and weather resistant
3. Be purple, double-sided, and manufactured from polyurethane
4. Have an integral neck attachment and attachment hole capable of withstanding 178 lb of pull-out resistance
5. Have hot-stamped black lettering

Posts and hardware for warning signs must comply with section 56-4.

Concrete sprinkler protectors used with recycled water must be painted purple.

20-2.01B(4) Location Markers

Location markers must be schedule 40 white PVC plastic pipe.

20-2.01B(5) Pull Boxes

Pull boxes must comply with section 86-2.06 and be no. 5 or larger unless otherwise shown. Pull boxes for low voltage conductors must not have side openings.

Pull box covers used solely for irrigation electrical service must be marked "IRRIGATION".

20-2.01B(6) Unions

Unions must be brass or malleable iron capable of withstanding the maximum required working pressure.

20-2.01B(7) Valve Boxes and Covers

Valve boxes must be precast concrete.

Covers must be:

1. Concrete, steel, or cast iron.
2. Marked "WATER" in cast-in letters not less than 1 inch high.
3. 1 piece, except 2 pieces are required when the weight of the valve box cover exceeds 35 lb.

The valve box covers must include a polyurethane label with the appropriate controller letter and station number as shown.

20-2.01B(8) Wye Strainers

Wye strainers must:

1. Have a cast iron or all bronze body
2. Have a removable stainless steel strainer screen:
 - 2.1. With an open area equal to at least 3 times the cross-sectional area of the pipe based on an iron pipe size

- 2.2. With 40-mesh woven wire, except:
 - 2.2.1. For a backflow preventer assembly, the screen must be 20-mesh woven wire mesh or perforated sheet with 0.045-inch diameter holes
 - 2.2.2. For a valve assembly, the screen must be 80-mesh woven wire mesh
3. Be capable of withstanding a working pressure of 150 psi
4. Be equipped with a garden valve at the outlet

The wye strainer filter housing must:

1. Withstand a working pressure of 150 psi
2. Be manufactured of reinforced polypropylene plastic

20-2.01C Construction

20-2.01C(1) General

05-30-14

Immediately shut off water to broken supply lines, valves, or sprinkler assemblies. Repair irrigation systems within 24 hours after a malfunction or damage occurs.

07-19-13

Connect underground metallic pipes, valves, or fittings made of dissimilar metals through a dielectric coupling or bushing.

You may install conduits, conductors, and supply lines by methods other than trenching provided that they are not damaged and are installed at the depths specified.

20-2.01C(2) Trenching and Backfilling

Trench and backfill under section 86-2.01.

Remove plants under 20-1.03C as necessary to perform trenching. If plants are to remain, adjust trench alignment to minimize damage.

If removal of:

1. Turf is required, remove to a maximum width of 12 inches.
2. Groundcover is required, remove to a maximum width of 6 feet. Existing *Carpobrotus* and *Delosperma* may be rototilled if the backfill for the trenches does not contain plants longer than 6 inches in length.

Make a 2-inch deep sawcut along neat lines around the perimeter of the pavement to be removed at locations determined by the Engineer.

The trench must have uniform bearing throughout the entire length and must be free of jagged rubble or sharp objects. Ensure conduit, supply line, and joints are not moved or damaged by backfill operations.

For a project with multiple water service points, excavate and backfill trenches for 1 service point at a time.

11-15-13

Trenches for irrigation supply lines and conduits 3 inches and larger must be 5 times the pipe or conduit diameter deep and 2 times the pipe or conduit diameter wide.

Trenches for irrigation supply lines and conduits 2-1/2 inches or less in diameter must be a minimum of 12 inches below finished grade, measured from the top of the installed pipe.

07-19-13

Trenches must be at least 4 feet from curbs, dikes, and paved shoulders.

Rocks and debris encountered during trenching operations must be brought to the surface of the ground. Remove rocks and debris as ordered. This work is change order work.

If trenching requires the removal of plants, in areas with:

1. Turf, replace turf with sod under section 20-3.03C(3)(e).
2. Groundcover, replace groundcover plants from flats and plant at 12 inches on center under section 20-3.03C. No replacement of *Carpobrotus* and *Delosperma* is required if removed by rototilling.

11-15-13

Where existing surfacing is removed, replace the structural section to match the materials removed. Replacement concrete must be of uniform smoothness, color, and texture equal to the adjacent concrete surface. Dispose of removed material. Install supply line and conduits at the bottom of trenches and backfill with sand to a depth of 2 inches over the top of the supply lines and conduits. Excluding the part of the trench backfilled with surfacing or pavement, the remainder of the trench must be backfilled with material that is excavated from the trench. Rock, broken concrete, asphalt concrete and other particles larger than 2 inches in greatest dimension must not be used.

07-19-13

20-2.01C(3) Pull Boxes

Install pull boxes under section 86-2.06 at the following locations:

1. At all conductor splices except splices made in valve boxes
2. Within 5 feet of irrigation controllers
3. At ends of electrical conduits
4. At other locations shown

20-2.01C(4) Valve Boxes and Covers

Install and identify each valve box as shown.

In walkways and paved areas, install the top of the valve box flush with the surrounding finished grade.

20-2.01C(5) Recycled Water Warning Signs

Install recycled water warning signs on irrigation facilities using recycled water.

Install sign decals directly to clean, smooth surfaces. Clean the surface with alcohol or an equivalent cleaner before applying the decal.

Install a 4 by 4 inch warning sign decal to each:

1. Backflow preventer assembly
2. Irrigation controller enclosure cabinet door

Install a 2 by 2 inch warning tag to the each remote control valve and valve box cover.

Install a 2-1/2 by 3 inches sign decal to each sprinkler riser.

Under local regulations, install a 12 by 12 inch warning sign decal on an aluminum plate and attach to gates, fences, and walls located in the vicinity of a recycled water irrigation system. On gates and fences, install signs with S hooks and C clips or 14-gauge galvanized steel wire. On concrete walls or other rough surfaces, install signs with a silicon-based adhesive.

20-2.01C(6) Garden Valves

Furnish 3 keys for each garden valve before Contract acceptance.

20-2.01D Payment

Not Used

20-2.02 EXISTING IRRIGATION FACILITIES

20-2.02A General

20-2.02A(1) Summary

Section 20-2.02 includes specifications for checking, testing, operating, replacing, and relocating existing irrigation facilities.

20-2.02A(2) Definitions

Reserved

20-2.02A(3) Submittals

Submit a list of irrigation system deficiencies within 7 days after checking the existing facilities.

20-2.02A(4) Quality Control and Assurance

After irrigation facilities have been relocated, demonstrate in the presence of the Engineer that the relocated facilities function properly.

Certify each existing backflow preventer under section 20-2.03A(4).

20-2.02B Materials

Valve box covers must be the same size as the covers they replace.

Control and neutral conductors must be the same size and color as the control and neutral conductors they replace.

20-2.02C Construction

20-2.02C(1) General

Notify the Engineer at least 4 business days before shutting off the water supply to any portion of the existing irrigation system and immediately after restoring the water supply to any portion of the existing irrigation system.

If an irrigation facility to be relocated is determined unsuitable by the Engineer, replace irrigation facility under section 20-2. This work is change order work.

20-2.02C(2) Check and Test Existing Irrigation Facilities

Before performing irrigation system work, check existing irrigation facilities to remain in place or to be relocated. The Engineer determines the test watering cycle lengths. Check for deficiencies including missing parts, damaged components, and improper operation. Correct deficiencies as ordered. The correction of deficiencies is change order work.

20-2.02C(3) Operate Existing Irrigation Facilities

If the Contract includes a bid item for operate existing irrigation facilities, after performing work under section 20-2.02C(2), operate existing irrigation facilities through Contract acceptance.

Operate existing irrigation facilities except for water meters, underground supply lines, control and neutral conductors, and electrical conduits.

Check for proper operation at least once every 30 days. Adjust, repair, or replace existing irrigation facilities within 7 days of finding any deficiency.

Operate irrigation systems using the automatic irrigation controller until Contract acceptance. You may operate irrigation controllers manually during plant replacement, fertilization, weed germination, and repair work.

Program the irrigation controllers for seasonal requirements.

20-2.02C(4) Replace Valve Box Covers

Existing valve box covers shown to be replaced must remain in place until the new covers are ready to be installed.

Dispose of removed valve box covers.

20-2.02C(5) Relocate Backflow Preventer Assemblies

Relocate backflow preventer assembly as shown and install under section 20-2.03C.

20-2.02C(6) Relocate Water Meters

Relocate water meter as shown.

20-2.02C(7) Relocate Irrigation Controllers

Relocate irrigation controller as shown and install under section 20-2.07C.

20-2.02D Payment

Not Used

20-2.03 BACKFLOW PREVENTER ASSEMBLIES

20-2.03A General

20-2.03A(1) Summary

Section 20-2.03 includes specifications for installing a backflow preventer assembly.

20-2.03A(2) Definitions

Reserved

20-2.03A(3) Submittals

Reserved

20-2.03A(4) Quality Control and Assurance

Each backflow preventer assembly must be certified by a backflow preventer tester. The tester must have an active and valid certification from the water purveyor having jurisdiction.

If the local water purveyor does not have a certification program, the tester must be certified by AWWA or a nearby county with a certification program.

Notify the Engineer at least 5 business days before certifying backflow preventer assembly.

Certify each backflow preventer assembly annually and within 10 days before Contract acceptance.

20-2.03B Materials

20-2.03B(1) General

Each backflow preventer assembly must include:

1. Backflow preventer including gate valve, wye strainer, brass or malleable iron unions, fittings, and supports
2. Blanket
3. Enclosure
4. Concrete pad

Concrete for the pad must be minor concrete, except the concrete must not contain less than 463 pounds of cementitious material per cubic yard. Hand mixing of the concrete is allowed.

20-2.03B(2) Backflow Preventers

Each backflow preventer must:

1. Be reduced-pressure principle type.
2. Comply with the requirements of the water purveyor that has jurisdiction.
3. Be factory-assembled with:
 - 3.1. 2 check valves
 - 3.2. 1 pressure differential relief valve
 - 3.3. 4 test cocks
 - 3.4. 2 shut-off valves manufactured from iron or bronze. Shut-off valves must be one of the following:
 - 3.4.1. Resilient wedge gate valves
 - 3.4.2. Resilient seated and fully ported ball valves
 - 3.4.3. Resilient seated butterfly valves

Backflow preventer components must be capable of withstanding a working pressure of 150 psi.

20-2.03B(3) Backflow Preventer Blankets

Each backflow preventer blanket must:

1. Be polyester fabric coated with vinyl or polymeric resin
2. Be resistant to UV light, water, mildew, and fire
3. Have an R-value from R-30 to R-38

Blankets must have a securing mechanism that includes either zippers, hook-pile tape, grommets, snaps, buttons, or any combination of these. Wherever the backflow preventer is not in an enclosure, the securing mechanism must be capable of accepting a padlock.

20-2.03B(4) Backflow Preventer Enclosures

Each backflow preventer enclosure must:

1. Have expanded metal sides, ends, and top panels fabricated from 9-gauge minimum thickness stainless sheet steel with openings of approximately 3/4 by 1-3/4 inches
2. Have expanded metal panels attached to the 3/16-inch thick steel frame by a series of welds not less than 1/4 inch in length and spaced not more than 4 inches on center, along the edges of the enclosure

3. Have Type 304 stainless steel lock guards with a minimum thickness of 12 gauge.
4. Have hexagonal nuts and lock-type washers
5. Be powder coated by the manufacturer to match color no. 20450 of FED-STD-595.
6. Have padlock clasp or latch and lock mechanism

20-2.03C Construction

Finish exposed top surfaces of concrete pad with a medium broom finish applied parallel to the long dimension of pads.

Install hold-downs for the backflow preventer assembly enclosure when concrete is still plastic.

20-2.03D Payment

Not Used

20-2.04 CAM COUPLER ASSEMBLIES

20-2.04A General

Section 20-2.04 includes specifications for installing a cam coupler assembly.

20-2.04B Materials

Each cam coupler assembly must consist of a cam coupler, dust cap, check valve, pipes, fittings, concrete thrust block, and valve box with woven wire cloth and gravel.

Cam couplers and keys must be manufactured of brass or bronze and be able to withstand a working pressure of 150 psi.

Furnish 3 loose cam coupler keys before Contract acceptance.

20-2.04C Construction

Install cam coupler assemblies in valve boxes as shown.

20-2.04D Payment

Not Used

20-2.05 CONTROL AND NEUTRAL CONDUCTORS

20-2.05A General

20-2.05A(1) Summary

Section 20-2.05 includes specifications for installing control and neutral conductors.

20-2.05A(2) Definitions

Reserved

20-2.05A(3) Submittals

Reserved

20-2.05A(4) Quality Control and Assurance

Perform field tests on control and neutral conductors. Field tests must comply with the specifications for lighting circuits in section 86-2.14B.

Where the conductors are installed by trenching and backfilling, perform field tests after a minimum of 6 inches of backfill material has been placed and compacted over the conductors.

20-2.05B Materials

Control and neutral conductors must comply with the requirements in section 86-2.08.

For connections between 24-volt irrigation controllers and valve solenoids, use control and neutral conductors. Conductors must include a control conductor for each valve and a common neutral.

Conductor insulation color, except for the stripes, must be continuous throughout. The color of the conductors must be consistent from the controller to each valve. Neutral conductors must be white. Do not use white for control conductors. Do not use conductors with green insulation except as permitted by the NEC.

Conductors must be:

1. No. 12 AWG or larger or no. 14 AWG or larger for armor-clad
2. Rated for 36 V or 600 V for armor-clad
3. Rated for direct burial
4. Underground feeder cable Type UF and TWU
5. Solid, uncoated copper for armor-clad
6. Not less than 90 percent of the AWG diameter required

No. 10 and smaller conductors must be insulated with a minimum of 56 mils of PVC or a minimum of 41 mils of polyethylene. No. 8 and larger conductors must be insulated with a minimum of 70 mils of PVC.

No. 10 and smaller armor-clad conductors must be insulated with a minimum of 41 mils of polyethylene. No. 8 and larger armor-clad conductors must be insulated with 54 to 60 mils of PVC.

Armor-clad conductors must include:

1. Stainless steel tape armor, Type 304 and helically wrapped with a 33 percent minimum overlap. The tape must be 0.5 inch wide and at least 0.005 inch thick.
2. PVC outer conductor jacket that is UV resistant and complies with the ICEA S-61-402, NEMA standard WC5 and UL listing 1263. The jacket nominal thickness must be 24 to 30 mils thick.

20-2.05C Construction

20-2.05C(1) General

Reserved

20-2.05C(2) In Open Trenches

Do not install control and neutral conductors above each other in an open trench. Wrap conductors together with electrical tape at 5 foot intervals.

Where conductors are installed in the same trench as supply line, install at the same depth as the line. At other locations, install conductors not less than 12 inches below finished grade.

Where conductors are not in a supply line trench, install conductors at least 4 feet from curbs, dikes, and paved shoulders.

20-2.05C(3) In Conduits

Install conductors in electrical conduit if conductors are to be:

1. Surface mounted
2. Installed in or on structures

3. Installed under paved areas
4. Installed in irrigation conduits
5. Placed in concrete

20-2.05C(4) Splicing

Splice low voltage control and neutral conductors under sections 86-2.09C, 86-2.09D, and 86-2.09E, except do not use method B. Tape used for splice insulation must be PVC tape.

Leave at least 2 feet of slack for each conductor at each:

1. Pull box
2. Valve box for each conductor that is connected to other facilities within the box or spliced within the box

Do not splice conductors in irrigation controller cabinets.

Permanent splice connections must be made with freshly cut and skinned conductors. Do not use temporary splices made for testing valve circuits as permanent splices.

20-2.05C(5) Marking

Mark control and neutral conductors in pull boxes, valve boxes, at irrigation control terminals, and at splices.

Mark conductor terminations and splices with adhesive cloth wrap-around markers. Seal markers with clear, heat-shrinkable sleeves.

Mark nonspliced conductors with clip-on C-shaped white extruded PVC sleeves. Sleeves must have black indented legends of uniform depth with transparent overlays over the legends and chevron cuts for the alignment of 2 or more sleeves.

Identify markers for the control conductors with the appropriate irrigation controller and station number.

20-2.05D Payment

Not Used

20-2.06 FLOW SENSORS

20-2.06A General

Section 20-2.06 includes specifications for installing a flow sensor.

20-2.06B Materials

Each flow sensor must be an inline type with a nonmagnetic spinning impeller as the only moving part.

The electronics housing must:

1. Be schedule 80 PVC or cast 85-5-5-5 bronze
2. Include glass-filled polyphenylene sulfide
3. Be easily removable from the meter body and include 2 ethylene-propylene O-rings

The impeller must be tungsten carbide.

The electronics must be rated to withstand prolonged water immersion conditions and include 2 single conductor 18 AWG leads, 48 inches long.

The insulation must be direct burial UF type colored red for the positive lead and black for the negative lead.

The flow sensor must be capable of withstanding:

1. 100 to 400 psi operating pressure depending on sensor size shown
2. Liquid temperatures up to 220 degrees F
3. Flows from 1/2 to 15 ft/sec

20-2.06C Construction

Install flow sensor as shown.

20-2.06D Payment

Not Used

20-2.07 IRRIGATION CONTROLLERS

20-2.07A General

20-2.07A(1) Summary

Section 20-2.07 includes specifications for installing irrigation controllers.

20-2.07A(2) Definitions

irrigation controller: "Smart" irrigation controller as defined by the Irrigation Association.

remote irrigation control system (RICS): Centralized water management system that consists of a base station, centralized server, satellite controllers.

base station: Designated computer located at a Department maintenance facility or District Office that collects data from a series of satellite controllers through a centralized server.

centralized server: Designated server or web-based application that collects data from all base stations.

web-based application: Encrypted managing software that is coded in a browser-supported language and is executable via a common internet web browser (e.g., Microsoft Internet Explorer, Firefox, Safari, etc.).

satellite controller: Irrigation controller that communicates directly to a base station or centralized server.

network communication: Identified means through which satellite controllers, base stations, and a centralized server communicate to one another (i.e., fiber optics, spread spectrum, phone line, etc.).

remote access device: Device (i.e., FCC compliant radio remote, cell phone or wireless, etc.) used to communicate with satellite controllers from a remote location.

20-2.07A(3) Submittals

Submit as an informational submittal, a complete manufacturer's maintenance and operations manual for each type of controller installed. Submit the manual at the time the wiring plans and diagrams are placed inside the controller enclosure or cabinet door.

20-2.07A(4) Quality Control and Assurance

Provide training by a qualified person on the use and adjustment of the irrigation controllers installed 30 days before Contract acceptance.

Modifications to electrical components must be done by the manufacturer before shipment to the job site.

The installation date and expiration date of the manufacturer's guarantee for the controllers must be permanently marked on the inside face of the controller.

20-2.07B Materials

20-2.07B(1) General

Conventional A/C powered irrigation controllers must operate on 110/120 V, 60 Hz(ac) and supply 24 to 30 VAC, 60 Hz(ac) for operating electrical remote control valves.

Concrete for the pad and foundation must be minor concrete, except the concrete must not contain less than 463 pounds of cementitious material per cubic yard. Hand mixing of the concrete is allowed.

20-2.07B(2) Irrigation Controllers

20-2.07B(2)(a) General

The irrigation controllers must:

1. Be A/C, battery, solar, or 2-wire as shown
2. Be from a single manufacturer.
3. Be fully automatic and capable of operating a complete 30-day or longer irrigation program.
4. Have a switch or button on the face of the irrigation control panel showing that the irrigation controller can be turned on or off and provide for automatic or manual operation. Manual operation must allow cycle start at the desired station and allow for the minimum activation of a single station or have the option to operate multiple stations in sequential or simultaneous operation modes.
5. Have non-volatile memory.
6. Have a watering time display on the face of the control panel.
7. Have a panel and circuit board connected to the low voltage control and neutral conductors by means of a plug and receptacle connectors located within the cabinet enclosure.
8. Have a variable or incremental timing adjustment ranging from 1 minute to 360 minutes per station.
9. Be capable of operating at least 3 program schedules.
10. Be capable of having at least 4 start times per program schedule.
11. Have an output that can energize a pump start circuit or a remote control master valve.
12. Be protected by fuses and circuit breakers.
13. Display a program and station affected by a sensory alert without altering other watering schedules not affected by the alert.
14. Be capable of global manual and automatic seasonal adjustments to all valves in any given program.
15. Automatically alter watering schedule in accordance with evapotranspiration data provided by a local weather station or have an internal programmed default of historical evapotranspirational data for a given region.
16. Support a flow sensor, rain sensor, or weather station and have automatic shut-off capability.
17. Be capable of communicating with the remote access device.

If the irrigation controller is installed in an enclosure cabinet, the cabinet must be stainless steel and must comply with section 86-3.04A.

Irrigation controllers not installed in enclosure cabinets must be weatherproof, constructed of fiberglass or metal and have a door lock with 2 keys provided.

RICS must meet the requirements of an irrigation controller and be capable of being accessible only through a secured and encrypted server that is password and firewall protected by the Department or be accessible through a firewall secure remote server that is independent from any Department servers. The Department will set up and manage the network communication.

20-2.07B(2)(b) Battery Powered Irrigation Controllers

Reserved

20-2.07B(2)(c) Solar Powered Irrigation Controllers

Reserved

20-2.07B(2)(d) Two-wire Irrigation Controllers

Reserved

20-2.07B(3) Irrigation Controller Enclosure Cabinets

The irrigation controller enclosure cabinet must:

1. Be stainless steel.
2. Include a mounting panel. Fabricate mounting panels with one of the following:
 - 2.1. 3/4-inch exterior AC grade veneer plywood. Paint panels with 1 application of an exterior, latex based, wood primer and 2 applications of an exterior, vinyl acrylic enamel, white in color. Paint panels on all sides and edges before installation of the panels in the cabinets and the equipment on the panels.
 - 2.2. 3/16-inch thick aluminum sheets.
 - 2.3. 10-gauge cold-rolled steel sheets.
 - 2.4. 0.157-inch stainless steel metal sheets.
3. Provide cross ventilation, roof ventilation, or a combination of both. Ventilation must not compromise the weather resistance properties of the cabinet and must be fabricated by the cabinet manufacturer.
4. Include protection against lightning damage.
5. Have an area inside the cabinet doors for storage of the as-built schematic wiring diagram and irrigation plans.
6. Have padlock clasp or latch and lock mechanism.

20-2.07B(4) Rain Sensors

A rain sensor unit must be a solid state, automatic shut-off type, and compatible with the irrigation controller. The rain sensor unit must automatically interrupt the master remote control valves when approximately 1/8 inch of rain has fallen. The irrigation controller must automatically be enabled again when the accumulated rainfall evaporates from the rain sensor unit collection cup.

Rain sensor units must be one of the following:

1. Rated 24 V(ac) to 30 V(ac)
2. Wireless and FCC compliant

20-2.07C Construction

Finish exposed top surface of concrete pad with a medium broom finish applied parallel to the long dimension.

Locate irrigation controllers in pedestal or wall mounted enclosures as shown.

Install electrical components for automatic irrigation systems under section 86-1.02.

Install irrigation controllers under the manufacturer's instructions and as shown.

If 2 or more irrigation controllers operate the same remote master control valve, furnish and install an isolation relay under the controller manufacturer's instructions.

Where direct burial conductors are to be connected to the terminal strip, connect the conductors with the open-end-crimp-on wire terminals. Exposed wire must not extend beyond the crimp of the terminal and the wires must be parallel on the terminal strip.

Install rain sensor units for irrigation controllers on the irrigation controller enclosure cabinets. Provide protection against lightning damage.

20-2.07D Payment

Payment for electrical service for 120-volt or higher is not included in the payment for irrigation controller.

20-2.08 IRRIGATION CONDUIT

20-2.08A General

20-2.08A(1) Summary

Section 20-2.08 includes specifications for installing irrigation conduit under a roadway or other facility to accommodate electrical conduit for control and neutral conductors and irrigation supply lines.

Before performing work on irrigation systems, locate existing conduits shown to be incorporated into the new work.

Before removing or disturbing existing Type A pavement markers that show the location of the existing conduit, mark the location of the existing conduit on the pavement.

20-2.08A(2) Definitions

Reserved

20-2.08A(3) Submittals

Reserved

20-2.08A(4) Quality Control and Assurance

Demonstrate the conduits are free of obstructions after placement of base and surfacing.

Before and after extending the irrigation supply line in a conduit, pressure test the supply line under section 20-2.01A(4)(b).

After conductors are installed in a conduit, test the conductors under section 20-2.05A(4).

Assign a technical representative to direct and control the directional bore activities. The representative must be present during directional bore activities. Unless otherwise authorized, perform directional bore activities in the presence of the Engineer.

20-2.08B Materials

20-2.08B(1) General

Reserved

20-2.08B(2) ABS Composite Pipe Conduit

ABS composite pipe and couplings must comply with ASTM D 2680. Couplings must be solvent cement type.

20-2.08B(3) Corrugated High Density Polyethylene Pipe Conduit

Corrugated high density polyethylene pipe must comply with ASTM F 405 and F 667 or be Type S and comply with AASHTO M252 and M294. Couplings and fittings must be as recommended by the pipe manufacturer.

20-2.08B(4) Corrugated Steel Pipe Conduit

Corrugated steel pipe conduit must comply with section 66. The nominal thickness of metal sheets for pipe must be 0.064 inch for corrugated steel pipe and 0.060 inch for corrugated aluminum pipe. Coupling bands and hardware must comply with section 66.

20-2.08B(5) Polyvinyl Chloride Pipe Conduit

PVC pipe conduit must be schedule 40 and comply with ASTM D 1785.

Fittings must be schedule 80.

20-2.08B(6) Welded Steel Pipe Conduit

Welded steel pipe must comply with ASTM A 53. Pipe must be black and have either welded or threaded joints.

The minimum wall thickness for the various sizes of welded steel pipe must comply with the dimensions shown in the following table:

Pipe size, nominal (inch)	Minimum wall thickness (inch)
3	0.216
4	0.237
6	0.280
8	0.277
10	0.279
12	0.330

20-2.08C Construction

20-2.08C(1) General

When existing conduits are to be incorporated in new work, excavate exploratory holes for locating existing conduits at the locations indicated by existing markers or as directed. Excavate and backfill exploratory holes to a maximum size of 2-1/2 feet in width, 5 feet in depth, and 5 feet on each side of the marker or directed location parallel to the roadway. If the conduit is not found and if ordered, increase the size of the exploratory holes beyond the dimensions specified. The additional excavation and backfill is change order work.

If extending an existing conduit, remove conductors from the conduit.

Use a coupling band if the new conduit matches the existing conduit diameter, otherwise overlap the conduit at least 12 inches.

After extending existing conduits, install conductors that match the color and size of the existing conductors without splices. Splice conductors in adjacent pull boxes.

If installing a control and neutral conductor and electrical conduit through the irrigation conduit, install a no. 5 pull box at each end.

Remove debris found in the conduit before performing other work. Debris found more than 3 feet from the ends of the conduits is removed as change order work.

Extend conduit 2 feet beyond all paving unless otherwise shown.

Cap the ends of unused conduit.

Designate the location of each conduit by cementing a Type A pavement marker as shown. Type A pavement markers and adhesive must comply with section 85.

20-2.08C(2) Welded Steel Pipe Conduit

20-2.08C(2)(a) General

Install welded steel pipe by directional boring or jack and drill.

Install top of conduits:

1. 18 to 30 inches below the finished surface in sidewalk areas
2. 40 to 52 inches below the finished grade in other paved areas

20-2.08C(2)(b) Directional Boring

Notify the Engineer 2 business days before starting directional bore activities.

The diameter of the boring tool for directional boring must be only as large as necessary to install the conduit.

Mineral slurry or wetting solution may be used to lubricate the boring tool and to stabilize the soil surrounding the boring path. The mineral slurry or wetting solution must be water based.

The directional bore equipment must have directional control of the boring tool and have an electronic boring tool location detection system. During operation, the directional bore equipment must be able to determine the location of the tool both horizontally and vertically.

20-2.08C(2)(c) Jack and Drill

Notify the Engineer 2 business days before starting jack and drill activities.

Jacking or drilling pits must be no closer than 2 feet from pavement edge whenever possible.

If authorized, small holes may be cut in the pavement to locate or remove obstructions.

Do not use excessive water that will soften subgrade or undermine pavement.

20-2.08C(3) Schedule 40 Pipe Conduit

Where schedule 40 pipe conduit 2 inches or less in outside diameter is installed under surfacing, you may install by directional boring under section 20-2.08C(2)(b).

For conduit 2 inches or less in diameter, the top of the conduit must be a minimum of 18 inches below surfacing.

Extend schedule 40 pipe conduit 6 inches beyond surfacing. Cap ends of conduit until used.

20-2.08D Payment

Schedule 40 PVC pipe conduit is paid for as plastic pipe (schedule 40) (supply line).

20-2.09 IRRIGATION SUPPLY LINE

20-2.09A General

20-2.09A(1) Summary

Section 20-2.09 includes specifications for installing irrigation supply line.

If the supply line location interferes with the excavation of plant holes, relocate the plant hole to clear the supply line. Do not install supply lines through plant holes unless shown.

Supply lines, control and neutral conductors and electrical conduits installed in common trenches must not be installed above each other.

20-2.09A(2) Definitions

Reserved

20-2.09A(3) Submittals

Submit a certificate of compliance for polyethylene pipe and plastic pipe supply line.

20-2.09A(4) Quality Control and Assurance

Solvent cement must comply with the local Air Quality Management District requirements.

20-2.09B Materials

20-2.09B(1) General

Irrigation supply pipe must be metal or plastic as shown.

PCC for thrust blocks must be produced from commercial-quality aggregates. The concrete must contain at least 295 pounds of cementitious material per cubic yard.

20-2.09B(2) Copper Pipe Supply Line

Copper pipe must be Type K rigid pipe and comply with ASTM B 88. Fittings must be wrought copper or cast bronze either soldered or threaded.

Solder must be 95 percent tin and 5 percent antimony.

20-2.09B(3) Galvanized Steel Pipe Supply Line

Galvanized steel pipe supply line and couplings must be standard weight and comply with ASTM A 53, except that the zinc coating must not be less than 90 percent of the specified amount. Except for couplings, fittings must be galvanized malleable iron, banded and threaded, and comply with ANSI B16.3, Class 150.

Joint compound must be nonhardening and noncorrosive. Do not use pipe thread sealant tape.

20-2.09B(4) Drip Irrigation Tubing

Drip irrigation tubing must be virgin polyethylene plastic and comply with ASTM D 2737.

The drip irrigation tubing must be distribution tubing with preinstalled in-line emitters.

If preinstalled in-line drip irrigation tubing is not shown, you may install emitters that match the distribution requirements shown. The emitters must be barbed or threaded-type outlet devices with dual silicone diaphragms and installed under the manufacturer's instructions.

The emitters must meet the flow rate and operating pressure range shown.

The wall thickness of polyethylene tubing must comply with the following requirements when tested under ASTM D 2122:

Pipe size, nominal (inch)	Minimum wall thickness (inch)	Maximum wall thickness (inch)
1/2	0.050	0.070
5/8	0.055	0.075
3/4	0.060	0.080

The polyethylene tubing fittings must be leak-free, compression type and have female sockets with an internal barb to provide a positive pipe-to-fitting connection that will not separate at the designed pressure.

20-2.09B(5) Plastic Pipe Supply Line

Plastic pipe supply line must be PVC pipe that is NSF approved.

Schedule 40 plastic pipe supply line must comply with ASTM D 1785.

Class 315 plastic pipe supply line must comply with ASTM D 2241.

PVC gasketed bell joints must comply with ASTM D 2672, ASTM D2241, ASTM D 3139, and ASTM F 477.

For solvent-cemented type joints, the primer and solvent cement must be made by the same manufacturer. The primer color must contrast with the color of the pipe and fittings.

Solvent-cemented fittings must be injection molded PVC, schedule 40, and comply with ASTM D 2466.

Fittings for supply line placed in irrigation conduit must be schedule 80.

Fittings for plastic pipe supply line larger than 4 inches must be ductile iron under section 20-2.14C(2)(b).

If UV-resistant plastic pipe supply line is required, the pipe must be homogeneous, uniform color and be manufactured of:

1. At least 80 percent vinyl chloride resin with UV stabilizers
2. Non-PVC resin modifiers and coloring ingredients
3. Coloring ingredients with UV stabilizers

20-2.09C Construction

20-2.09C(1) General

Cut pipe straight and true. After cutting, ream out the ends to the full inside diameter of the pipe.

05-30-14

Prevent foreign material from entering the irrigation system during installation. Immediately before assembling, clean all pipes, valves, and fittings. Flush lines before attaching sprinklers, emitters, and other terminal fittings. Reuse water from waterline flushing for landscape irrigation if practicable.

07-19-13

Pipe supply lines installed between the water meter and backflow preventer assembly must be installed not less than 18 inches below finished grade measured to the top of the pipe.

Where a connection is made to existing supply lines, bell and gasketed fittings or compression fittings may be used.

Install a thrust block at each change in direction on the main supply line, terminus run, and at other locations shown.

Where supply lines cross paved ditches more than 3 feet deep at their flow line, install galvanized steel pipe for the entire span of the ditch.

Secure UV resistant plastic pipe supply line on grade as shown.

20-2.09C(2) Galvanized Steel Pipe Supply Line

Coat male pipe threads on galvanized steel pipe according to the manufacturer's instructions.

20-2.09C(3) Drip Irrigation Tubing

Install drip irrigation tubing on grade and under manufacturer's instructions.

Install a flush valve and an air-relief valve if recommended by the drip valve assembly manufacturer.

20-2.09C(4) Plastic Pipe Supply Line

For PVC pipe 1-1/2 inches in diameter or smaller, cut the pipe with PVC cutters.

For solvent-cemented type joints, apply primer and solvent-cement separately under the manufacturer's instructions.

Wrap the male portion of each threaded plastic pipe fitting with at least 2 layers of pipe thread sealant tape.

Install plastic pipe supply line mains with solvent-cemented type joints not less than 18 inches below finished grade measured to the top of the pipe.

Install plastic pipe supply line laterals with solvent-cemented type joints not less than 12 inches below finished grade measured to the top of the pipe.

Snake plastic pipe installed by trenching and backfilling methods.

20-2.09D Payment

Supply line pipe and drip irrigation tubing are measured along the slope.

20-2.10 SPRINKLER ASSEMBLIES

20-2.10A General

Section 20-2.10 includes specifications for installing sprinkler assemblies.

20-2.10B Materials

20-2.10B(1) General

Each sprinkler assembly must meet the characteristics shown in the irrigation legend.

Where shown, a sprinkler assembly must have a flow shut-off device that automatically stops the flow of water on the downstream side of the device when the assembly is broken. You may use a sprinkler assembly with a preinstalled flow shut-off device or you must install a flow shut-off device under the manufacturer's instructions.

Flexible hose for sprinkler assembly must be leak-free, nonrigid and comply with ASTM D 2287, cell Type 6564500. The hose wall thickness must comply with ASTM D 2122 for the hose diameters shown in the following table:

Hose diameter, nominal (inch)	Minimum wall thickness (inch)
1/2	0.127
3/4	0.154
1	0.179

Solvent cement and fittings for flexible hose must comply with section 20-2.09B(5).

20-2.10B(2) Pop-Up Sprinkler Assemblies

Each pop-up sprinkler assembly must include a body, nozzle, swing joint, pressure compensation device, check valve, sprinkler protector, and fittings as shown.

20-2.10B(3) Riser Sprinkler Assemblies

11-15-13

Each riser sprinkler assembly must include a riser or flexible hose, threaded nipple, swing joint, check valve, and nozzle as shown. The riser must be UV resistant schedule 80, PVC 1120 or PVC 1220 pipe and comply with ASTM D 1785.

20-2.10B(4) Tree Well Sprinkler Assemblies

Each tree well sprinkler assembly must include a body, riser, swing joint, perforated drainpipe, and drain cap.

07-19-13

The perforated drainpipe must be commercial grade, rigid, PVC pipe with holes spaced not more than 6 inches on center on 1 side of the pipe.

Drain cap must be commercially available, 1 piece, injection molded drain grate manufactured from structural foam polyolefins with UV light inhibitors. Drain grate must be black.

Gravel for filling the drainpipe must be graded such that 100 percent passes the 3/4-inch sieve and 100 percent is retained on the 1/2-inch sieve. Gravel must be clean, washed, dry, and free from clay or organic material.

20-2.10C Construction

Install pop-up and riser sprinkler assembly:

1. 6-1/2 to 8 feet from curbs, dikes, and sidewalks
2. 10 feet from paved shoulders
3. 3 feet from fences and walls

If sprinkler assembly cannot be installed within these limits, the location will be determined by the Engineer.

Set sprinkler assembly riser on slopes perpendicular to the plane of the slope.

Install tree well sprinkler assembly as shown.

20-2.10D Payment

Not Used

20-2.11 VALVES

20-2.11A General

Section 20-2.11 includes specifications for installing valves.

20-2.11B Materials

20-2.11B(1) General

Valves must:

1. Include a valve box and cover
2. Be the same size as the supply line that the valve serves unless otherwise shown
3. Be bottom, angled, or straight inlet configuration

20-2.11B(2) Ball Valves

Ball valve must be a two-piece brass or bronze body and comply with the requirements shown in the following table:

Property	Requirements
Nonshock working pressure, min	400 psi
Seats	PTFE
O-ring seals	PTFE

Ball valve must be the same size as the supply line that the valve serves.

20-2.11B(3) Check Valves

Each check valve must:

1. Be schedule 80 PVC and factory set to 5 psi for adjustable spring check valve
2. Be Class 200 PVC for swing check valves on non pressurized plastic irrigation supply line

20-2.11B(4) Drip Valve Assemblies

Each drip valve assembly must include:

1. Remote control valve
2. Wye filter with:
 - 2.1. Filter housing that:
 - 2.1.1. Can withstand a working pressure of 150 psi
 - 2.1.2. Is manufactured of reinforced polypropylene plastic
 - 2.2. Reusable stainless steel filter cartridge with a 200 mesh size filtration
3. Ball valve under 20-2.11B(2)
4. Schedule 80 PVC pipes and fittings
5. Pressure regulator

20-2.11B(5) Garden Valve Assemblies

Each garden valve assembly must have:

1. Garden valve
2. Location marker

20-2.11B(6) Gate Valves

Gate valves must be:

1. Flanged or threaded type
2. Iron or bronze body
3. Bronze trimmed with one of the following:
 - 3.1. Internally threading rising stem
 - 3.2. Nonrising stem
4. Able to withstand a working pressure of 150 psi
5. Same size as the pipeline that the valves serves unless otherwise shown

Gate valves smaller than 3 inches must have a cross handle.

Gate valves 3 inches or larger must be flanged type with a square nut. Furnish 3 long shank keys before Contract acceptance.

Gate valves attached to the outlets of a wye strainer must have seating rings on the discharge side of the gate valves must be PTFE. Valve wedges must be driven obliquely by cam action into the seating rings.

20-2.11B(7) Pressure Regulating Valves

Pressure regulating valve must be:

1. Flanged or threaded type
2. Brass, bronze, cast iron, or plastic body
3. Spring diaphragm type
4. Pilot controlled

Pressure regulating valve must have no internal filter screens.

20-2.11B(8) Pressure Relief Valves

Pressure relief valve must have a brass or bronze body, stainless steel springs, bronze nickel chrome seats, composition seat discs, female bottom inlets, and female side outlets.

20-2.11B(9) Quick Coupling Valves

Quick coupling valve must be 3/4 inch double slotted with a self-closing cap, 3/4-inch brass key and 3/4-inch brass hose swivel unless otherwise shown. Except for the cap, quick coupling valve must be brass or bronze construction. Furnish 3 loose quick coupling brass keys and brass hose swivels before Contract acceptance.

20-2.11B(10) Remote Control Valves

20-2.11B(10)(a) General

Each remote control valve must:

1. Be normally closed type.
2. Be glass filled nylon, brass, or bronze.
3. Be completely serviceable from the top without removing the valve body from the system.
4. Be equipped with a device that regulates and adjusts the flow of water and be provided with a manual shut-off. The manual shut-off for valves larger than 3/4 inch must be operated by a cross handle.
5. Have solenoids compatible with the irrigation controller.
6. Have a manual bleed device.
7. Be capable of withstanding a pressure of 200 psi
8. Have replaceable compression discs or diaphragms.
9. Have threaded fittings for inlets and outlets.
10. Have DC latching solenoids when used with solar or battery controllers. Solenoids must operate on 3.5 V.

20-2.11B(10)(b) Remote Control Valves with Flow Sensor

Reserved

20-2.11B(10)(c) Remote Control Valves with Pressure Regulator

Each remote control valve with pressure regulator must be factory assembled as 1 unit.

20-2.11B(11) Wye Strainer Assemblies

Each wye strainer assembly must include:

1. Wye strainer
2. Garden valve

20-2.11C Construction

20-2.11C(1) General

Install control valves:

1. 6-1/2 to 8 feet from curbs, dikes, and sidewalks
2. 10 feet from paved shoulders
3. 3 feet from fences, walls, or both

If a control valve cannot be installed within these limits, the location will be determined by the Engineer.

20-2.11C(2) Check Valves

Unless otherwise shown, install spring-action check valves as necessary to prevent low head drainage.

20-2.11C(3) Garden Valve Assemblies

Install a location marker 8 to 10 inches from the back of each garden valve.

20-2.11C(4) Pressure Regulating Valves

Install pressure regulating valves with threaded connections and a union on the inlet side of the valves.

20-2.11C(5) Wye Strainer Assemblies

Unless shown, install wye strainer assembly on the upstream side of the remote control valves.

Install garden valve so that when the system is flushed, the discharge sprays out of the valve box.

20-2.11D Payment

Not Used

05-30-14

20-2.12–20-2.13 RESERVED

07-19-13

20-2.14 SUPPLY LINE ON STRUCTURES

20-2.14A General

20-2.14A(1) General

20-2.14A(1)(a) Summary

Section 20-14 includes specifications for installing water supply lines through bridges and on the exterior of concrete structures.

20-2.14A(1)(b) Definitions

Reserved

20-2.14A(1)(c) Submittals

Submit a work plan for temporary casing support at the abutments as an informational submittal.

20-2.14A(1)(d) Quality Control and Assurance

20-2.14A(1)(d)(i) General

Before installing seismic expansion assemblies or expansion assemblies, the Engineer must authorize the extension setting.

20-2.14A(1)(d)(ii) Regulatory Requirements

Piping materials must bear the label, stamp, or other markings of the specified standards.

20-2.14A(1)(d)(iii) Site Tests

Test water supply lines before:

1. Backfilling
2. Beginning work on box girder cell decks
3. Otherwise covering the water supply lines

Furnish pipe anchorages to resist thrust forces occurring during testing.

Test the water supply lines as 1 unit. The limits of the unit must be 5 feet beyond the casing at each end of the bridge.

Cap each end of the water supply lines before testing. Caps must be rated for the test pressure.

Test water supply lines under section 20-2.01A(4)(b), except that the testing period must be 4 hours with no pressure drop.

For water supply lines 4 inches and larger testing must meet the following additional requirements:

1. Testing pressure must be at least 120 psi
2. Air relief valve must not be subjected to water pressure due to testing

If water supply lines fail testing, retest the lines after repair.

20-2.14A(2) Materials

20-2.14A(2)(a) General

Protect stored piping from moisture and dirt. Elevate piping above grade. Support piping to prevent sagging and bending.

Protect flanges, fittings, and assemblies from moisture and dirt.

20-2.14A(2)(b) Air Release Valve Assemblies

Air release valve assemblies include an air release valve, ball valve, tank vent, nipples, and pipe saddle. Assemblies must comply with the following:

1. Air release valves must have a cast iron body with stainless steel trim and float, 1-inch NPT inlet, 1/2-inch NPT outlet, and 3/16-inch orifice.
2. Ball valves must have a 2-piece bronze body with chrome plated or brass ball, 1-inch full-size port, and be rated for at least 400 psi.
3. Tank vents must have a 1/2-inch NPT inlet and downward-facing double openings with screened covers.
4. Nipples must be schedule 40 galvanized steel pipe.
5. Pipe saddle must be rated for at least 150 psi and compatible with water supply line. Pipe saddle must be (1) single strap pipe saddle for water supply lines smaller than 4 inches or (2) double strap pipe saddle for water supply lines 4 inches and larger. You may use a tee fitting for galvanized steel water supply lines.

20-2.14A(2)(c) Casings

Casings must be welded steel pipe casing complying with section 70-7.

20-2.14A(2)(d) Pipe Wrap Tape

Pipe wrap tape must be pressure sensitive tape made from PVC or polyethylene. Pipe wrap tape must be at least 50 mils thick and not wider than 2 inches.

20-2.14A(2)(e) Pipe Hangers

Pipe hangers must comply with section 70-7.02C.

The pipe hanger must be rated for the water supply line. If casings are shown, include the casings weight.

20-2.14A(2)(f) Epoxy Adhesives

Epoxy used for anchoring concrete pipe supports must comply with section 70-7.02D.

20-2.14A(2)(g) Concrete Pipe Supports

Concrete pipe supports must comply with section 70-7.02D.

20-2.14A(2)(h) Pipe Clamps and Anchors

Metal clamps must be commercial quality steel complying with section 75-1.02. Anchors must comply with the specifications for concrete anchorage devices in section 75-1.03C.

20-2.14A(2)(i) Pull Boxes

Pull boxes and covers must comply with section 20-2.01B(5).

20.2.14A(3) Construction

20-2.14A(3)(a) General

Support water supply lines as described.

Where water supply lines penetrate bridge superstructure concrete, either form or install pipe sleeves at least 2 pipe sizes larger than the pipe.

20-2.14A(3)(b) Preparation

Clean the interior of the pipe before installation. Cap or plug openings as pipe is installed to prevent the entrance of foreign material. Leave caps or plugs in place until the next pipe section is installed.

20-2.14A(3)(c) Installation

20-2.14A(3)(c)(i) General

Reserved

20-2.14A(3)(c)(ii) Casings

Install casings under section 70-7.03.

Seal casing end with 8 inches of polyurethane foam at dirt stop or pipe end seal.

20-2.14A(3)(c)(iii) Wrapping Water Supply Line

Wrap damaged supply line coatings with pipe wrap tape. Wrap field joints and fittings that are in contact with the earth.

Wrapping must comply with the following:

1. Clean and prime area as recommended by the tape manufacturer.
2. Tightly wrap tape with 1/2 uniform overlap, free from wrinkles and voids, to provide not less than a 100 mil thickness.
3. The tape must conform to joint or fitting contours.
4. Extend tape at least 6 inches over adjacent pipe.

20-2.14A(3)(c)(iv) Pipe Clamps and Anchors

Install water supply lines on the exterior surfaces of bridges or other concrete structures with metal clamps and anchors.

Drilling of holes for anchors must comply with the following:

1. Drill holes to manufacturers recommended depth.
2. Drilling tools must be authorized.
3. Do not drill holes closer than 6 inches to the edge of a concrete structure.
4. Relocate holes if reinforcing steel is encountered. Fill abandoned holes with mortar. Mortar must comply with section 51-1.02F.

Where water supply lines are mounted vertically for more than 2 feet, install clamps and anchors within 6 inches of the elbows.

Where water supply lines are mounted vertically for more than 10 feet, install additional clamps and anchors at 10 foot centers unless otherwise shown.

20-2.14A(3)(d) Sequences of Operation

If the bridge superstructure is to be prestressed do not place mortar around casings in abutments and hinges until bridge superstructure prestressing has been completed.

20-2.14A(4) Payment

Supply line on structures is measured from end to end, along the centerline.

The Department does not pay for failed tests.

20-2.14B Supply Line on Structures, Less than 4 Inches

20-2.14B(1) General

20-2.14B(1)(a) Summary

Section 20-2.14B includes specifications for installing water supply lines smaller than 4 inches.

20-2.14B(1)(b) Definitions

Reserved

20-2.14B(1)(c) Submittals

Product data for materials includes catalog cuts, performance data, and installation instructions.

Submit product data for:

1. Water supply line
2. Expansion assemblies
3. Casing insulators
4. Pipe end seals
5. Pipe anchorages
6. Air release valve assemblies
7. Casings
8. Pipe hangers
9. Epoxy adhesives
10. Concrete pipe supports

20-2.14B(1)(d) Quality Control and Assurance

Reserved

20-2.14B(2) Materials

20-2.14B(2)(a) General

Reserved

20-2.14B(2)(b) Water Supply Line

Water supply lines must comply with section 20-2.09.

20-2.14B(2)(c) Expansion Assemblies

Expansion assemblies must consist of a hose with ends, insulated flange connections, and elbows. Expansion assemblies must have the same nominal inside diameter as the water supply line. Working pressure must be at least 150 psi.

Hose must be medium or heavy weight, crush and kink resistant, rated for at least 150 psi. Cover must be flexible, oil resistant rubber or synthetic, reinforced with at least 2-ply synthetic yarn or steel wire. The inner tube must meet FDA and USDA Standards for potable water. Hose ends must be stainless steel flanged connections with stainless steel crimped bands or swaged end connectors. Do not use barbed ends with band clamps.

Elbows must be 45 degree, standard weight galvanized steel fittings.

20-2.14B(2)(d) Casing Insulators

Casing insulators must be:

1. 2-piece, high-density, injection-molded polyethylene, nonconductive inner liner, with cadmium-plated nuts and bolts.
2. Factory constructed to ensure the water supply line is centered in the casing. Insulators must not allow any contact between pipe and casing and have at least 2 runners seated on the bottom of the casing.
3. Sized for the casing and water supply line shown.

20-2.14B(2)(e) Pipe Anchorages

Pipe anchorages must consist of an I-beam, U-bolts, anchors, and double nuts.

Use concrete anchorage devices for anchors on existing bridges. Use L-anchor bolts for anchors on new bridges.

Fabricate the I-beam from 1/2-inch steel plate. Steel plate, U-bolts, L-anchors, and nuts must comply with section 75-1.02. Concrete anchorage devices must comply with section 75-1.03C.

20-2.14B(2)(f) Pipe End Seals

Pipe end seals must consist of a pipe end seal, stainless steel bands, and polyurethane foam.

Pipe end seal must be factory constructed from seamless neoprene and sized for the casing and water supply line shown. Neoprene must be at least 1/8 inch thick. Stainless steel bands must be crimped.

Polyurethane foam must be expanding foam spray that is water resistant and moisture cured.

20-2.14B(3) Construction

Locate pipe anchorage halfway between expansion assemblies.

Pipe end seal must be pulled onto the casing during pipe installation. Do not use wrap-around type end seals.

20-2.14B(4) Payment

Supply line on structures is paid for as galvanized steel pipe (supply line on bridge).

20-2.14C Supply Line on Structures, 4 Inches and Larger

20-2.14C(1) General

20-2.14C(1)(a) Summary

Section 20-2.14C includes specifications for installing water supply lines 4 inches and larger.

20-2.14C(1)(b) Definitions

Reserved

20-2.14C(1)(c) Submittals

Product data for materials includes catalog cuts, performance data, and installation instructions.

Submit product data for:

1. Water supply line
2. Expansion assemblies
3. Flange insulating gaskets
4. Casing insulators
5. Seismic expansion assemblies
6. Lateral restraint assemblies
7. Air release valve assemblies
8. Casings
9. Pipe hangers
10. Epoxy adhesives
11. Concrete pipe supports

Submit the maximum range and preset dimension for each expansion assembly or seismic expansion assembly as an informational submittal.

Submit at least 5 sets of product data to OSD, Documents Unit. Each set must be bound together and include an index stating equipment names, manufacturers, and model numbers. Two sets will be returned. Notify the Engineer of the submittal. Include in the notification the date and contents of the submittal.

20-2.14C(1)(d) Quality Control and Assurance

Reserved

20-2.14C(2) Materials

20-2.14C(2)(a) General

Reserved

20-2.14C(2)(b) Water Supply Line

Water supply lines must consist of ductile iron pipe and fittings. Pipe must comply with ANSI/AWWA C151/A21.51, Class 350. Fittings must comply with ANSI/AWWA C110/A21.10, rated for a working pressure of 350 psi.

Ductile iron pipe connections to expansion assemblies must be a flanged joint complying with ANSI/AWWA C115/A21.15. Flange gaskets must be rated for a working pressure of 350 psi. Fasteners must comply with section 75-1.02, except that stainless steel fasteners must not be used.

All other ductile iron pipe and fitting joints must be push-on, restrained type complying with ANSI/AWWA C111/A21.11. Push-on, restrained type joints may use proprietary dimensions and proprietary restrained joint locking systems.

Ductile iron pipe and fittings must have an asphaltic coating complying with ANSI/AWWA C151/A21.51, and a cement mortar lining complying with ANSI/AWWA C104/A21.4.

20-2.14C(2)(c) Expansion Assemblies

Expansion assemblies must be a sleeve type expansion joint. The expansion assembly must have:

1. Ductile iron body complying with ANSI/AWWA C153/A21.53
2. Flanged ends complying with ANSI/AWWA C110/A21.10
3. Fusion bonded epoxy internal lining complying with ANSI/AWWA C213 at least 15 mils thick
4. Internal expansion sleeve limiting stop collars and be pressure balanced
5. Working pressure of at least 350 psi for sizes 24 inches and smaller and 250 psi for sizes larger than 24 inches
6. NSF 61 certification

The expansion assembly must be factory set at 1/2 the extension capacity.

20-2.14C(2)(d) Flange Insulating Gaskets

Flange insulating gaskets must consist of a dielectric flange gasket, insulating washers and sleeves, and commercial quality steel bolts and nuts. Dielectric flange gasket must have a dielectric strength of at least 500 vpm.

20-2.14C(2)(e) Casing Insulators

Casing insulators must be:

1. 2-piece, 8-inch, 14-gauge epoxy-coated or galvanized steel band, four 2-inch-wide glass-reinforced polyester or polyethylene runners, with cadmium-plated nuts and bolts.
2. Coated with at least 15-mils heat-fused PVC to provide a nonconductive inner liner.
3. Factory constructed to ensure the water supply line is centered in the casing. Insulators must not allow any pipe to casing contact and have at least 2 runners seated on the bottom of the casing.
4. Sized for the casing and water supply line shown.

20-2.14C(2)(f) Dirt Stops

Dirt stops must consist of a redwood cover with polyurethane foam.

Use construction heart grade redwood complying with 57-2.01B(2). Construct cover to fit snugly around the water supply line. The cover must be 2 inches taller and 2 inches wider than the casing.

Polyurethane foam must be expanding foam spray that is water resistant and moisture cured.

20-2.14C(2)(g) Seismic Expansion Assemblies

Seismic expansion assemblies must be a sleeve type expansion joint with integral ball joints at each end.

Seismic expansion assemblies must have:

1. Ability to withstand at least 15 degree angular deflection at each end and maximum movement in all 3 planes at the same time
2. Ductile iron body complying with ANSI/AWWA C153/A21.53
3. Flanged ends complying with ANSI/AWWA C110/A21.10
4. Fusion bonded epoxy internal lining complying with ANSI/AWWA C213 at least 15 mils thick
5. Internal expansion sleeve limiting stop collars and pressure balanced
6. Ball joints contained in flanged retainers with seal gaskets

7. Working pressure of at least 350 psi for sizes 24 inches and smaller and 250 psi for sizes larger than 24 inches
8. NSF 61 certification

The seismic expansion assembly must be factory set at 1/2 the extension capacity.

20-2.14C(2)(h) Lateral Restraint Assemblies

Lateral restraint assemblies must be (1) constructed from commercial quality steel components complying with section 75-1.02, (2) adjustable, and (3) able to resist a horizontal force of 10 percent of the contributory dead load.

20-2.14C(3) Construction

Each ductile iron pipe must be connected and fully extended (pulled out) after joint assembly before the next pipe section is added.

Install flange insulating gaskets on the outside flange of seismic expansion assemblies and expansion assemblies.

20-2.14C(4) Payment

Supply line on structures is paid for as supply line (bridge).

20-2.15 TEMPORARY IRRIGATION SYSTEMS

Reserved

20-2.16–20-2.19 RESERVED

20-3 PLANTING

20-3.01 GENERAL

20-3.01A General

20-3.01A(1) Summary

Section 20-3 includes specifications for performing planting work in new and existing landscapes.

20-3.01A(2) Definitions

Reserved

20-3.01A(3) Submittals

20-3.01A(3)(a) General

Submit nursery invoices showing species or variety and inspection certificates for plants.

Submit documentation of clearance from the county agricultural commissioner for plants obtained from a county outside the project limits.

If a root stimulant is required, submit a copy of the root stimulant manufacturer's product sheet and instructions for the application of the root stimulant.

If cuttings are to be taken from outside the right-of-way, submit proof of permits and payment of associated fees. Notify the Engineer of the location at least 15 days before taking cuttings.

20-3.01A(3)(b) Vendor Statements

At least 60 days before planting the plants, submit a statement from the vendor that the order for the plants required, including sample plants used for inspection, has been received and accepted by the vendor. The statement from the vendor must include the plant names, sizes, and quantities and the anticipated delivery date.

20-3.01A(3)(c) Certificates of Compliance

Submit a certificate of compliance for:

1. Sod
2. Soil amendment

20-3.01A(4) Quality Control and Assurance

Plants must comply with federal and state laws requiring inspection for diseases and infestations. Inspection certificates required by law must accompany each shipment of plants.

Obtain clearance from the county agricultural commissioner before planting plants delivered from a county outside the project limits.

The Engineer inspects the roots of container-grown sample plants by removing earth from the rootball of not less than 2 plants, nor more than 2 percent of the total number of plants of each species or variety. If container-grown plants are purchased from several sources, the Engineer inspects the roots of not less than 2 of each sample plant species or variety from each source. The rootball of container grown plants must not show evidence of being underdeveloped, deformed, or having been restricted.

If the Engineer finds noncompliant plants, the entire lot represented by the noncompliant sample plants will be rejected.

Cuttings with mature or brown stems and cuttings that have been trimmed will be rejected.

20-3.01B Materials

20-3.01B(1) General

Notify the Engineer at least 10 days before the plants are shipped to the job site.

20-3.01B(2) Plants

20-3.01B(2)(a) General

Plants must be the variety and size shown and true to the type or name shown. Plants must be individually tagged or tagged in groups identifying the plants by species or variety. Tagging is not required for cuttings.

Plants must be healthy, well-formed, not root-bound, free from insect pests and disease, and grown in nurseries inspected by the Department of Food and Agriculture.

The plants must comply with the size and type shown in the following table:

Plant group designation	Description	Container size (cu in)
A	No. 1 container	152–251
B	No. 5 container	785–1242
C	Balled and burlapped	--
E	Bulb	--
F	In flats	--
H	Cutting	--
I	Pot	--
K	24-inch box	5775–6861
M	Liner ^a	--
O	Acorn	--
P	Plugs ^{a, b}	--
S	Seedling ^c	--
U	No. 15 container	2768–3696

^aDo not use containers made of biodegradable material.

^bGrown in individual container cells.

^cBare root.

Trucks used for transporting plants must be equipped with covers to protect plants from windburn. Handle and pack plants in an authorized way for the species or variety.

20-3.01B(2)(b) Cuttings

20-3.01B(2)(b)(i) General

Take cuttings at random from healthy, vigorous plants. Make cuts with sharp, clean tools. Do not take more than 25 percent of an individual plant and not more than 50 percent of the plants in an area.

Keep cuttings covered and wet until planted. Do not allow cuttings to dry or wither.

Plant cuttings no more than 2 days after being cut.

20-3.01B(2)(b)(ii) *Carpobrotus* and *Delosperma* Cuttings

You may take cuttings for new *Carpobrotus* and *Delosperma* groundcover from the existing highway planting areas, but these areas may not provide enough material to complete the work. Contact the local District’s encroachment permit office to obtain a permit to harvest cuttings, identify acceptable cutting harvest areas, and to determine acceptable quantities to take.

Take tip cuttings from healthy, vigorous *Carpobrotus* and *Delosperma* plants that are free of pests and disease.

Carpobrotus cuttings must be 10 inches or more in length and not have roots.

Delosperma cuttings must be 6 inches or more in length and not have roots.

20-3.01B(2)(b)(iii) Willow Cuttings

Take willow cuttings from areas shown or designated by the Engineer.

Willow cuttings must be:

1. Reasonably straight
2. 20 to 24 inches in length
3. 3/4 to 1-1/2 inch in diameter at the base of the cutting

Cut the top of each willow cutting square above a leaf bud. Cut the base below a leaf bud at approximately a 45 degree angle. Trim off leaves and branches flush with the stem of the cutting.

20-3.01B(2)(b)(iv) Cottonwood Cuttings

Cottonwood cuttings must comply with the requirements for willow cuttings in section 20-3.01B(2)(b)(iii).

20-3.01B(2)(b)(v)–20-3.01B(2)(b)(viii) Reserved

20-3.01B(2)(c) Sod

Sod must:

1. Be grown to comply with the Food & Agri Code
2. Be free from weeds and undesirable types of grasses and clovers
3. Be field-grown on soil containing less than 50 percent silt and clay
3. Have less than 1/2-inch-thick thatch
4. Not be less than 8 months or more than 16 months old
5. Be machine-cut to a uniform soil thickness of $5/8 \pm 1/4$ inch, not including top growth and thatch

Protect sod with tarps or other protective covers during delivery. Do not allow sod to dry out during delivery or before placement.

20-3.01B(3) Soil Amendment

Soil amendment must comply with the requirements in the Food & Agri Code. Soil amendment must be one or a combination of the following:

1. Sphagnum peat moss
2. Nitrolized fir bark
3. Vermiculite
4. Perlite

20-3.01B(4) Fertilizers

20-3.01B(4)(a) General

Deliver fertilizer in labeled containers showing weight, chemical analysis, and manufacturer's name.

Fertilizer must comply with the requirements of the Food & Agri Code.

20-3.01B(4)(b) Slow-release Fertilizers

Slow-release fertilizer must be a pelleted or granular form with a nutrient release over an 8 to 12 month period and must comply with the chemical analysis ranges shown in the following table:

Ingredient	Content (percent)
Nitrogen (N)	16–21
Phosphoric acid (P)	6–8
Water soluble potash (K)	4–10

20-3.01B(4)(c) Packet Fertilizers

Packet fertilizer must be a biodegradable packet with a nutrient release over a 12 month period. Each packet must have a weight of 10 ± 1 grams and must comply with the chemical analysis shown in the following table:

Ingredient	Content (percent)
Nitrogen(N)	20
Phosphoric acid (P)	10
Water soluble potash (K)	5

20-3.01B(4)(d) Organic Fertilizers

Organic fertilizer must be pelleted or granular with a cumulative nitrogen release rate of no more than 70 percent for the first 70 days after incubation at 86 degrees F with 100 percent at 350 days or more. Organic fertilizer must comply with the chemical analysis shown in the following table:

Ingredient	Content (percent)
Nitrogen (N)	5–7
Phosphoric acid (P)	1–5
Water soluble potash (K)	1–10

20-3.01B(5) Root Stimulants

Root stimulant must be a commercial quality product.

20-3.01B(6) Plaster Sand

Backfill material for the transplant palm tree planting holes must be 100 percent commercial quality washed plaster sand.

20-3.01B(7) Root Barrier

Root barrier must be an injection molded or extruded modular panel made of high-density polypropylene or polyethylene plastic.

Each panel must:

1. Be at least 1/16-inch thick
2. Have at least 4 molded root-deflecting vertical ribs 0.5- to 0.8-inch wide, 6 to 8 inches apart

3. Have a locking strip or an integral male-female sliding lock designed to resist slippage between panels
4. Be at least 2 feet wide and 2 feet in depth

20-3.01B(8) Root Protectors

Each root protector must be:

1. Fabricated from 1-inch, hexagonal pattern, 20-gauge mesh wire
2. Closed bottom design with a height and diameter that provides a minimum of 6 inches of clearance between the root ball and the sides and bottom of the wire cylinder

Wire edges at the top of the cylinder must be the uncut manufactured finished edge free of sharp points.

20-3.01B(9) Foliage Protectors

Each foliage protector must be:

1. Fabricated from 1-inch, hexagonal pattern, 20-gauge mesh wire
2. Approximately 4 feet high and 2 feet in diameter

Wire edges at the top of the cylinder must be the uncut manufactured finished edge free of sharp points. Other wire edges that are cut must be free of sharp points.

Support stakes must be one of the following:

1. 3/4-inch reinforcing steel bar a minimum of 5 feet long with an orange or red plastic safety cap that fits snugly onto the top of the reinforcing steel bar
2. 2 inch nominal diameter or 2 by 2 inch nominal size wood stakes a minimum of 5 feet long. Wood stakes must be straight

The jute mesh cover must comply with section 21-1.02O(2). Twine required to hold the jute mesh cover in place must be 1/8-inch diameter manila hemp twine.

20-3.01B(10) Wood Plant Stakes

Each plant stake must be nominal 2 by 2 inch or nominal 2-inch diameter and of sufficient length to keep the plant in an upright position.

Plant stakes for vines must be nominal 1 by 1 inch, 18 inches long.

20-3.01B(11) Plant Ties

Plant ties must be extruded vinyl-based tape, 1 inch wide and at least 10 mils thick.

20-3.01C Construction

20-3.01C(1) General

Apply a root stimulant under the manufacturer's instructions to the plants specified in the special provisions.

Before transporting the plants to the planting area, thoroughly wet the root ball.

20-3.01C(2) Pruning

Prune plants under the latest edition of ANSI A300 part 1, *Pruning*, published by the Tree Care Industry Association.

Do not use tree seal compounds to cover pruning cuts.

20-3.01C(3) Watering

Water existing plants to be maintained, transplanted trees, and new plants as needed to keep the plants in a healthy growing condition.

20-3.01C(4) Replacement Plants

Plants that show signs of failure to grow at any time or are so injured or damaged as to render them unsuitable for the purpose intended, must be removed, replaced, and replanted. Replace unsuitable plants within 2 weeks after the Engineer marks or indicates that the plants must be replaced.

Replacement planting must comply with the original planting requirements, spacing, and size provisions described for the plants being replaced.

Replacement planting for transplanted trees must comply with the work plan and be planted in the same planting hole.

Replacement ground cover plants must be the same species specified for the ground cover being replaced. Other replacement plants must be the same species as the plants being replaced.

Place orders for replacement plants with the vendor at the appropriate time so that the replacement plants are not in a root-bound condition.

The Department does not pay for replacement plants or the planting of replacement plants.

20-3.01C(5) Maintain Plants

Maintain plants from the time of planting until Contract acceptance if no plant establishment period is specified or until the start of the plant establishment period.

20-3.01D Payment

Reserved

20-3.02 EXISTING PLANTING

20-3.02A General

20-3.02A(1) Summary

Section 20-3.02 includes specifications for pruning existing plants, transplanting trees, and maintaining existing planted areas.

Transplant palm trees between March 15 and October 15.

20-3.02A(2) Definitions

Reserved

20-3.02A(3) Submittals

Submit a work plan for:

1. Transplanting trees. The work plan must include methods for lifting, transporting, storing, planting, guying, and maintaining each tree to be transplanted. Include root ball size, method of root ball containment, and a maintenance program for each tree.
2. Maintaining existing planted areas. The work plan must include weed control, fertilization, mowing and trimming of turf areas, watering, and controlling rodents and pests.

Submit a copy of the manufacturer's product sheet for root stimulant including application instructions.

20-3.02A(4) Quality Control and Assurance

Inspect for deficiencies of existing planted areas in the presence of the Engineer. Complete the inspection within 15 days after the start of job site activities.

Deficiencies requiring corrective action include:

1. Weeds
2. Dead, diseased, or unhealthy plants
3. Missing plant stakes and tree ties
4. Inadequate plant basins and basin mulch
5. Other deficiencies needing corrective action to promote healthy plant life
6. Rodents and pests

20-3.02B Materials

Not Used

20-3.02C Construction

20-3.02C(1) General

Correct deficiencies of existing planted areas as ordered within 15 days of the order. Correction of deficiencies is change order work.

After deficiencies are corrected, perform work to maintain existing planted areas in a neat and presentable condition and to promote healthy plant growth through Contract acceptance.

20-3.02C(2) Prune Existing Plants

Prune existing plants as shown.

If no bid item for prune existing plants is included, prune existing plants as ordered. Pruning existing plants is change order work.

20-3.02C(3) Transplant Trees

Prune each tree to be transplanted immediately before lifting.

If the tree to be transplanted is a palm, prune by removing dead fronds and frond stubs from the trunk. Remove green fronds up to 2 rows of fronds away from the center of growth. Tie the remaining 2 rows of fronds in an upright position with light hemp or manila rope. Remove fronds and frond stubs at the trunk in a manner that will not injure the trunk. Remove fronds and frond stubs for *Phoenix dactylifera* (Date Palm) approximately 4 inches from the trunk.

Prepare each hole in the new location before lifting the tree to be transplanted.

Lift tree to be transplanted as described in the work plan.

Comply with section 20-3.03C(3) for handling and planting each tree to be transplanted.

Until replanted, cover exposed root ball with wet burlap or canvas and cover the crown with 90 percent shade cloth.

Replant each tree on the same day it is lifted if possible. If the transplant location is not ready to receive the tree, store and maintain the tree to be transplanted until the transplant location is authorized. Store tree in an upright position.

Replace damaged transplanted tree under 20-3.01C(4) and with the number of trees specified in the special provisions.

The replacement trees must be planted in individual plant holes at the location determined by the Engineer within the area of the tree being replaced. Comply with section 20-3.03C(2) for the planting of the replacement trees.

20-3.02C(4) Maintain Existing Planted Areas

If a bid item for maintain existing planted areas is included, the existing plant basins must be kept well-formed and free of sediment. If the existing plant basins need repairs, and the basins contain mulch, replace the mulch after the repairs are done.

Control weeds within the existing planted area and:

1. From the existing planted area limit to the adjacent edges of paving and fences if less than or equal to 12 feet
2. From the existing planted area limit to 6 feet beyond the outer limit of the existing planted area if the adjacent edge of paving or fence is more than 12 feet away
3. Within a 3-foot radius from each existing tree and shrub

If no bid item for maintain existing planted areas is included, maintain existing planted areas as ordered. Maintain existing planted areas is change order work.

20-3.02D Payment

Not Used

20-3.03 PLANTING WORK

20-3.03A General

Section 20-3.03 includes specifications for planting plants.

20-3.03B Materials

Not Used

20-3.03C Construction

20-3.03C(1) General

Do not begin planting until authorized.

If an irrigation system is required, do not begin planting in an area until the functional test has been completed and authorized for the irrigation system serving that area.

20-3.03C(2) Preparing Planting Areas

The location of each plant is as shown unless the Engineer designates otherwise. If the Engineer designates the location, it will be marked by a stake, flag, or other marker.

Conduct work so the existing flow line in drainage ditches is maintained. Material displaced by your operations that interferes with drainage must be removed.

Where a minimum distance to a drainage ditch is shown, locate the plant so that the outer edge of its basin wall is at least the minimum distance shown for each plant involved.

Excavate each planting hole by hand digging or by drilling. The bottom of each planting hole must be flat. Do not use water for excavating the hole.

Unless a larger planting hole is specified, the planting hole must be large enough to receive the root ball or the total length and width of roots, backfill, amendments, and fertilizer. Where rock or other hard

material prohibits the hole from being excavated, a new hole must be excavated and the abandoned hole backfilled.

20-3.03C(3) Planting Plants

20-3.03C(3)(a) General

Do not plant plants in soil that is too wet, too dry, not properly conditioned as specified, or in an unsatisfactory condition for planting.

Do not distribute more plants than can be planted and watered on that day.

Water plants immediately after planting. Apply water until the backfill soil around and below the roots or ball of earth around the roots of each plant is thoroughly saturated. When watering with a hose, use a nozzle, water disbursement device, or pressure reducing device. Do not allow the full force of the water from the open end of the hose to fall within the basin around any plant. Groundcover plants in areas with an irrigation system must be watered by sprinklers. Several consecutive watering cycles may be necessary to thoroughly saturate the soil.

If shown, install root barriers between trees and concrete sidewalk or curb. Install panels flush with finished grade and join with locking strips or integral male-female sliding locks. Install barriers with root deflectors facing inward.

If a tree grate is shown, install root barrier panels 0.5 inch above finish grade or as shown.

Adjust planting locations so that each tree or shrub is at least 8 feet away from any sprinkler.

Where a tree, shrub, or vine is to be planted within a groundcover area or cutting planting area, plant it before planting groundcover or cuttings.

Where shrubs and groundcovers are shown to be planted in groups, the outer rows directly adjacent to the nearest roadway or highway fence must be parallel to the nearest roadway or highway fence. Stagger shrubs and groundcovers in adjacent rows. Adjust the alignment of the plants within the outer rows.

Core holes in concrete masonry block wall as shown.

Where a vine is to be planted against a wall or fence, plant it as close as possible to the wall or fence. If a vine planted next to a wall is to be staked, stake and tie the vine at the time of planting. A vine planted next to a fence must be tied to the fence at the time of planting.

Protect tree trunks from injury. Do not:

1. Drag tree
2. Use chains to move a tree
3. Lay tree on the ground

20-3.03C(3)(b) Trees, Shrubs, and Vines

After preparing holes, thoroughly mix soil amendment and granular fertilizer at the rate shown with native soil to be used as backfill material. Remove containers from plants in such a manner that the ball of earth surrounding the roots is not broken. Do not cut plant containers before delivery of the plants to the planting area. Plant and water plants immediately after removal from their containers.

Place packet fertilizer in the backfill within 6 to 8 inches of the ground surface and approximately 1 inch from the root ball. If more than 1 packet is required per plant, distribute the packets evenly around the root ball.

If a root stimulant is to be used, apply it according to the manufacturer's instructions.

If required, install root protectors in the plant holes as shown.

Ensure roots are not restricted or distorted.

Distribute backfill uniformly throughout the entire depth of the plant hole without clods or lumps. After the planting holes have been backfilled, jet water into the backfill with a pipe or tube inserted into the bottom of the hole until the backfill material is saturated for the full depth. If the backfill material settles below this level, add additional backfill to the required level. If a plant settles deeper than shown, replant it at the required level.

Remove nursery stakes after planting.

Install 2 plant stakes for each plant to be staked at the time of planting as shown. Ensure the rootball is not damaged.

Tie the plant to the stakes with 2 plant ties, 1 tie to each stake. Each tie must form a figure 8 by crossing the tie between the plant and the stake as shown. Install ties at the lowest position that will support the plant in an upright position. Ties must provide trunk flexibility but not allow the trunk to rub against the stakes. Wrap each end of the tie 1-1/2 turns around the stake and securely tie.

Construct a watering basin around each plant as shown.

If required, install a foliage protector:

1. Over the plant within 2 days after planting.
2. Vertically and centered over the plant as shown

If foliage protectors are required:

1. Cut the bottom of the wire cylinder to match the slope of the ground. Do not leave sharp points of wire after cutting. Sharp points must be bent over or blunted.
2. Install 2 support stakes for foliage protectors vertically and embed in the soil on opposite sides of the plant as shown and in a transverse direction to the prevailing wind.
3. Either weave the support stakes through the wire cylinder mesh at 6 inch maximum centers or fasten the wire cylinder to the support stakes at 6 inch maximum centers.
4. Wire cylinder must be snug against the support stakes but loose enough to be raised for pesticide application or to perform weeding within the plant basin.
5. Install jute mesh cover over the foliage protector and secure with twine as shown.

20-3.03C(3)(c) Groundcover Plants

Each groundcover planting area irrigated by a single control valve must be completely planted and watered before planting other groundcover planting areas.

Plant groundcover plants in moist soil, and in neat, straight rows, spaced as shown.

Apply fertilizer to groundcover plants and water into the soil immediately after planting.

20-3.03C(3)(d) Cuttings, Liners, Plugs, and Seedling Plants

20-3.03C(3)(d)(i) General

Apply fertilizer to cuttings, liners, plugs, and seedling plants and water immediately after planting.

Ensure the soil is moist to a minimum depth of 8 inches before planting cuttings.

If a root stimulant is to be used, apply it according to the manufacturer's instructions.

20-3.03C(3)(d)(ii) Willow Cuttings

Unless otherwise shown, for willow cuttings excavate planting holes perpendicular to the ground line by using a steel bar, auger, post hole digger, or similar tools. Holes must be large enough to receive the cuttings and fertilizer packet. Plant willow cuttings to the specified depths without damaging the bark.

Where rock or other hard material prohibits the excavation of the planting holes, excavate new holes and backfill the unused holes.

Plant willow cuttings during the period specified in the special provisions.

Apply root stimulant according to the manufacturer's instructions.

Plant the base of the cutting 10 to 12 inches deep with 3 to 5 bud scars exposed above the ground. If more than 5 bud scars are exposed, trim off the excess willow cutting length.

Place 1 fertilizer packet in the backfill of each cutting, 6 to 8 inches below the ground surface and approximately 1 inch from the cutting.

Backfill the plant holes with excavated material after planting. Distribute the excavated material evenly within the hole without clods, lumps, or air pockets. Compact the backfill so that the cutting cannot be easily removed from the soil. Do not damage the cutting's bark.

Dispose of trimmings and unused cuttings.

20-3.03C(3)(d)(iii) Cottonwood Cuttings

Reserved

20-3.03C(3)(d)(iv) *Carpobrotus* and *Delosperma* Cuttings

Plant *Carpobrotus* cuttings to a depth so that not less than 2 nodes are covered with soil. The basal end of *Delosperma* cuttings must not be less than 2 inches below the surface of the soil and the basal end of *Carpobrotus* cuttings must not be less than 4 inches below the surface of the soil.

Apply root stimulant to *Delosperma* cuttings before planting.

Do not plant *Carpobrotus* or *Delosperma* cuttings in soil that does not contain sufficient moisture at an average depth of 2 inches below the surface.

20-3.03C(3)(d)(v) Liner Plants

Plant liner plants during the period specified in the special provisions.

If a foliage protector is required, install under section 20-3.03C(3)(b).

20-3.03C(3)(d)(vi) Plug Plants

Plant plug plants during the period specified in the special provisions.

20-3.03C(3)(d)(vii) Seedling Plants

Plant seedling plants during the period specified in the special provisions.

20-3.03C(3)(e) Sod

After all other planting is performed, grade sod areas to drain and to a smooth and uniform surface. Fine grade and roll sod areas before placing sod.

Areas adjacent to sidewalks, edging, and other paved borders and surfaced areas must be 1 inch below the finished surface elevation of the facilities, after fine grading, rolling, and settlement of the soil.

Place sod such that the end of each adjacent strip is staggered a minimum of 2 feet. Place the edge and end of sod firmly against adjacent sod and against sidewalks, edging, and other paved borders and surfaced areas.

Lightly roll the entire sodded area to eliminate air pockets and ensure close contact with the soil after placement of sod. Water the sodded areas so that the soil is moist to a minimum depth of 4 inches after rolling. Do not allow the sod to dry out.

If irregular or uneven areas appear in the sodded areas, restore to a smooth and even appearance.

Trim sod to a uniform edge at sidewalks, edging, and other paved borders and surfaced areas. Trimming must be repeated whenever the edge of sod extends 1 inch beyond the edge of the edging, sidewalks, and other paved borders and surfaced areas. Remove and dispose of trimmed sod.

Mow sod when it has reached a height of 4 inches. Mow sod to a height of 2.5 inches.

20-3.03D Payment

Soil amendment is measured in the vehicle at the point of delivery.

Measurement for slow-release fertilizer, organic fertilizer, or iron sulfate is determined from marked weight or sack count.

Various sizes and types of plants are measured by either the product of the average plant density and the total area planted or by actual count of the living plants in place, determined by the Engineer. The average plant density is the number of living plants per sq yd determined from actual count of test areas chosen representing the total planted area. The size and location of the test areas is determined by you and the Engineer, except that the total area tested must be equal to not less than 3 percent nor more than 5 percent of the planted area being determined. The Engineer makes the final determination of the areas to be tested.

20-3.04–20-3.08 RESERVED

20-4 PLANT ESTABLISHMENT WORK

20-4.01 GENERAL

20-4.01A Summary

Section 20-4 includes specifications for performing plant establishment work.

Plant establishment consists of caring for the plants, including watering, fertilizing, pruning, replacing damaged plants, pest control, and operating and repairing of all existing irrigation facilities used and irrigation facilities installed as part of the new irrigation system.

Working days on which no work is required, as determined by the Engineer, will be credited as a plant establishment working day, regardless of whether or not you perform plant establishment work.

Working days whenever you fail to adequately perform plant establishment work will not be credited toward the plant establishment working days.

20-4.01B Definitions

Type 1 plant establishment: Plant establishment period with the number of working days specified for plant establishment beginning after all work has been completed except for plant establishment work and other bid items specified to be performed until Contract acceptance.

Type 2 plant establishment: Plant establishment period with the number of working days specified for plant establishment beginning after all planting work has been completed except for plant establishment work and other bid items specified to be performed until Contract acceptance, provided that the Contract must not be accepted unless the plant establishment work has been satisfactorily performed for at least the number of working days specified for plant establishment.

If maintenance and protection relief is granted for a completed portion of the work under section 5-1.38, Type 2 plant establishment period for the completed portion of the work is the time between completion of all planting work except for plant establishment work, and the granting of maintenance and protection relief, provided that the relief must not be granted unless the plant establishment work

in the completed portion of the work has been satisfactorily performed for at least the number of working days specified for the plant establishment period.

20-4.01C Submittals

20-4.01C(1) General

Submit seasonal watering schedules for use during the plant establishment period within 10 days after the start of the plant establishment period. Remote irrigation control system watering schedule must utilize the remote irrigation control system software program.

Submit updated watering schedules within 5 business days after any changes have been made to the authorized schedules.

Submit a revised watering schedule for each irrigation controller not less than 30 days before completion of the plant establishment period.

20-4.01C(2) Notification

The Engineer will notify you in writing when the plant establishment period begins and will furnish statements regarding the number of working days credited to the plant establishment period after the notification.

Notify the Engineer at least 5 business days before applying each application of fertilizer.

20-4.01D Quality Control and Assurance

Provide training by a qualified person on the use and adjustment of the irrigation controllers installed, 30 days before completion of the plant establishment period.

Perform a final inspection of the plant establishment work in the presence of the Engineer between 20 and 30 days before Contract acceptance.

20-4.02 MATERIALS

20-4.02A General

Reserved

20-4.02B Fertilizers

Fertilizer must comply with section 20-3.01B(5).

20-4.03 CONSTRUCTION

20-4.03A General

Remove trash and debris.

Surplus earth accumulated in roadside clearing and planting areas must be removed.

Trim and mow turf areas as specified for sod in section 20-3.03C(3)(e). Dispose of trimmed and mowed material.

If irregular or uneven areas appear within turf areas, restore to a smooth and even appearance. Reseed turf seed areas.

Remove the tops of foliage protectors if plants become restricted.

Remove foliage protectors, including support stakes, within 30 days before the completion of the plant establishment period.

Keep plant basin walls well formed.

Clean new wye strainers and existing wye strainers that are a part of the new irrigation system annually until the completion of the plant establishment period. The last cleaning must be done within 15 days before the completion of the plant establishment period.

Remove, clean, and reinstall new filters and existing filters that are a part of the new irrigation system annually until the completion of the plant establishment period. The last cleaning must be done within 15 days before the completion of the plant establishment period.

20-4.03B Plant Growth Control

Prune plants planted as part of the Contract as authorized.

Remove plant growth that extends within 2 feet of sidewalks, curbs, dikes, shoulders, walls or fences.

Remove proposed and existing ground cover from within the plant basins, including basin walls, turf areas, and planting areas within edging.

Vines next to walls and fences must be kept staked and tied. Train vines on fences and walls or through cored holes in walls.

20-4.03C Fertilizers

Apply fertilizer to the plants as specified and water into the soil after each application.

Apply fertilizer at the rates shown and spread with a mechanical spreader, whenever possible.

20-4.03D Weed Control

Control weeds under section 20-1.03C(3).

20-4.03E Plant Staking

Replace the plant stakes that are inadequate to support plants with larger stakes.

Remove plant stakes when the Engineer determines they are no longer needed.

20-4.03F Replacement Plants

Replacement plants must comply with section 20-3.01C(4).

Replacement of plants up to and including the 125th plant establishment working day must be with a plant of the same size as originally specified. Plants of a larger container size than those originally specified for replacement plants may be used during the first 125 working days of the plant establishment period.

Replacement of plants after the 125th plant establishment working day must comply with the following size requirements:

Plant size (Original)	Plant size (Replacement)
Pot/liner/plug/ seedling	No. 1 container
No. 1 container	No. 5 container
No. 5 container	No. 15 container

Other replacement plants must be the same size as originally specified.

Replacement ground cover plants must comply with the following spacing requirements:

Original spacing (inches)	On center spacing of replacement ground cover plants (inches)		
	Number of completed plant establishment working days		
	1–125	126–190	191–End of plant establishment period
9	9	6	6
12	12	9	6
18	18	12	9
24	24	18	12
36	36	24	18

20-4.03G Watering

Operate the electric automatic irrigation systems in the automatic mode unless authorized.

If any component of the electric automatic irrigation system is operated manually, the day will not be credited as a plant establishment working day unless the manual operation is authorized.

Water plants utilizing the remote irrigation control system software program unless authorized.

Implement the watering schedule at least 10 days before completion of the plant establishment period.

20-4.04 PAYMENT

Not Used

20-5 LANDSCAPE ELEMENTS

20-5.01 GENERAL

20-5.01A General

Section 20-5 includes specifications for constructing and installing landscape elements.

20-5.01B Materials

Not Used

20-5.01C Construction

Earthwork must comply with section 19.

20-5.01D Payment

Not Used

20-5.02 EDGING

20-5.02A General

Section 20-5.02 includes specifications for constructing landscape edging.

20-5.02B Materials

20-5.02B(1) General

Reserved

20-5.02B(2) Header Board Edging

Lumber for header board edging must be one of the following types:

1. Construction grade cedar
2. Pressure-treated Douglas fir
3. Construction heart grade redwood complying with section 57-2.01B(2)

Lumber must be:

1. Rough cut from sound timber.
2. Straight. Sweep must not exceed 1 inch in 6 feet.
3. Free from loose or unsound knots. Knots must be sound, tight, well spaced, and not to exceed 2 inches in size on any face.
4. Free of shakes in excess of 1/3 the thickness of the lumber.
5. Free of splits longer than the thickness of the lumber.
6. Free of other defects that would render the lumber unfit structurally for the purpose intended.

Edging anchors for header board edging must be stakes of the size and shape shown.

20-5.02B(3) Metal Edging

Metal edging must be commercial quality, made of aluminum or steel, and have an L-shaped design. Edging must be a minimum of 4 inches in height. The thickness must be as recommended by the manufacturer for the use intended.

Edging anchors must be from the same manufacturer as the metal edging.

20-5.02B(4) High Density Polyethylene Edging

HDPE edging must be commercial quality and a minimum of 4 inches in height. The thickness must be as recommended by the manufacturer for commercial installation for the use intended.

Edging anchors must be from the same manufacturer as HDPE edging.

20-5.02B(5) Concrete Edging

Concrete for edging must be minor concrete.

20-5.02B(6)–20-5.02B(10) Reserved

20-5.02C Construction

20-5.02C(1) General

Where edging is used to delineate the limits of inert ground cover or mulch areas, install edging before installing inert ground cover or mulch areas.

Saw cut surfaces where (1) asphalt concrete or concrete surfacing must be removed to permit the installation of edging and (2) no joint exists between the surfacing to be removed and the surfacing to remain in place. The surfacing must be cut in a straight line to a minimum depth of 2 inches with a power-

driven saw before the surfacing is removed. Spike or stake spacing must comply with the manufacturer's instructions for use and site conditions.

20-5.02C(2) Header Board Edging

Each stake must be driven flush with the top edge of the header board edging and the stake top must be beveled away from the header board at a 45 degree angle. Attach stake to header board with a minimum of two 12-penny hot dipped galvanized nails per stake.

20-5.02C(3) Metal and High Density Polyethylene Edging

Spike or stake spacing must comply with the manufacturer's instructions for use and site conditions.

20-5.02C(4) Concrete Edging

Construct and finish minor concrete edging under section 73-2.

20-5.02C(5)–20-5.02C(9) Reserved

20-5.02D Payment

Edging is measured parallel to the ground surface.

20-5.03 INERT GROUND COVERS AND MULCHES

20-5.03A General

20-5.03A(1) General

20-5.03A(1)(a) Summary

Section 20-5.03 includes specifications for installing inert ground covers and mulches.

20-5.03A(1)(b) Definitions

Reserved

20-5.03A(1)(c) Submittals

Submit:

1. Filter fabric product data including the manufacturer's product sheet and installation instructions
2. Certificate of compliance for filter fabric at least 5 business days before delivery of the material to the job site

20-5.03A(1)(d) Quality Control and Assurance

Reserved

20-5.03A(2) Materials

Soil sterilant must be oxadiazon granular preemergent and must comply with section 20-1.02C.

Filter fabric must be Class A. Staples for filter fabric must comply with section 21-1.02R.

20-5.03A(3) Construction

20-5.03A(3)(a) General

Before performing inert ground cover and mulch work, remove plants and weeds to ground level.

20-5.03A(3)(b) Earthwork

Excavate areas to receive inert ground cover or mulch to the depth shown. Maintain the planned flow lines, slope gradients, and contours of the job site. Grade subgrade to a smooth and uniform surface and compact to not less than 90 percent relative compaction.

20-5.03A(3)(c) Treatment of Soil

After compaction, apply soil sterilant at the maximum label rate. Do not apply soil sterilant more than 12 inches beyond the inert ground cover or mulch limits. The soil sterilant application and inert ground cover or mulch placement must be completed within the same work day.

20-5.03A(3)(d) Filter Fabric

Immediately before placing filter fabric, surfaces to receive filter fabric must be free of loose or extraneous material and sharp objects that may damage the filter fabric during installation.

Align fabric and place in a wrinkle-free manner.

Overlap adjacent rolls of the fabric from 12 to 18 inches. Spread each overlapping roll in the same direction. Fasten fabric with staples flush with the adjacent fabric to prevent movement of fabric by placement of inert ground cover or mulch.

Repair or replace fabric damaged during placement of inert ground cover or mulch with sufficient fabric to comply with overlap requirements.

20-5.03A(4) Payment

Not Used

20-5.03B Rock Blanket

20-5.03B(1) General

20-5.03B(1)(a) Summary

Section 20-5.03B includes specifications for placing rock blanket.

20-5.03B(1)(b) Definitions

Reserved

20-5.03B(1)(c) Submittals

Submit a 1 sq yd sample of the various rock sizes.

20-5.03B(1)(d) Quality Control and Assurance

Reserved

20-5.03B(2) Materials

20-5.03B(2)(a) General

Do not use filter fabric.

20-5.03B(2)(b) Concrete

Concrete must be minor concrete.

20-5.03B(2)(c) Rock

Rock must be clean, smooth, and obtained from a single source and must comply with the following grading requirements:

Grading Requirements

Screen size (inches)	Percentage passing
8	100
6	50-85
4	0-50

20-5.03B(2)(d) Mortar

Mortar must comply with section 51-1.02F.

20-5.03B(3) Construction

Place concrete as shown.

Rock must be placed while concrete is still plastic. Remove concrete adhering to the exposed surfaces of the rock.

Loose rocks or rocks with a gap greater than 3/8 inch must be reset by an authorized method. The rock gap is measured from the edge of the rock to the surrounding concrete bedding.

Place mortar as shown.

20-5.03B(4) Payment

Rock blanket is measured parallel to the rock blanket surface.

20-5.03C Gravel Mulch

20-5.03C(1) General

20-5.03C(1)(a) Summary

Section 20-5.03C includes specifications for placing gravel mulch.

20-5.03C(1)(b) Definitions

Reserved

20-5.03C(1)(c) Submittals

Submit a 5-lb sample of the gravel mulch.

20-5.03C(1)(d) Quality Control and Assurance

Reserved

20-5.03C(2) Materials

Gravel mulch must be:

1. Uniform gray color
2. From a single source only
3. Crushed rock that complies with the following grading requirements:

Grading Requirements

Sieve size	Percent passing
1-1/4 inch	100
3/4 inch	60-80
1/2 inch	45-65
No. 40	5-20

20-5.03C(3) Construction

Place gravel and compact by rolling.

The finished gravel mulch surface must be smooth and uniform, maintaining original flow lines, slope gradients, and contours of the job site.

20-5.03C(4) Payment

Gravel mulch is measured parallel to the gravel mulch surface.

20-5.03D Decomposed Granite

20-5.03D(1) General

20-5.03D(1)(a) Summary

Section 20-5.03D includes specifications for placing decomposed granite.

20-5.03D(1)(b) Definitions

Reserved

20-5.03D(1)(c) Submittals

Five business days before delivery of the materials to the job site, submit:

1. Solidifying emulsion product data including the manufacturers' product sheets and installation instructions
2. Certificate of compliance for solidifying emulsion
3. 5-lb sample of the decomposed granite

20-5.03D(1)(d) Quality Control and Assurance

Test plot must be:

1. Constructed at an authorized location
2. At least 3 by 12 feet
3. Constructed using the materials, equipment, and methods to be used in the work
4. Authorized before starting work

Notify the Engineer not less than 7 days before constructing the test plot.

The Engineer uses the authorized test plot to determine acceptability of the work.

If ordered, prepare additional test plots. Additional test plots are change order work.

If the test plot is not incorporated into the work, the Engineer may order you to remove it.

20-5.03D(2) Materials

20-5.03D(2)(a) General

Decomposed granite must be:

1. Uniform gray or tan color
2. From one source only
3. Crushed granite rock that complies with grading requirements shown in the following table:

Grading Requirements

Sieve size	Percent passing
3/8 inch	100
No. 4	95–100
No. 8	75–80
No. 16	55–65
No. 30	40–50
No. 50	25–35
No. 100	20–25
No. 200	5–15

Note:

Grading based upon AASHTO T11-82 and T27-82

20-5.03D(2)(b) Solidifying Emulsion

Solidifying emulsion must be either a water-based polymer or nontoxic organic powdered binder specifically manufactured to harden decomposed granite. The solidifying emulsion must not alter the decomposed granite color.

20-5.03D(3) Construction

Do not place decomposed granite during rainy conditions.

Mix solidifying emulsion thoroughly and uniformly throughout the decomposed granite and under the manufacturer's instructions. Mix the material in the field using portable mixing equipment, or delivered in mixer trucks from a local ready-mixed plant.

Place decomposed granite uniformly in layers no more than 1-1/2 inch thick. Compact each layer of decomposed granite to a relative compaction of not less than 90 percent. Begin compaction within 6 to 48 hours of placement.

If the material was mixed in the field, apply an application of solidifying emulsion after compaction as recommended by the manufacturer. Prevent runoff or overspray of solidifying emulsion onto adjacent paved or planting areas.

The finished decomposed granite surface must be smooth and uniform, compacted to a relative compaction of not less than 90 percent, maintaining original flow lines, slope gradients, and contours of the job site.

20-5.03D(4) Payment

Not Used

20-5.03E Wood Mulch

20-5.03E(1) General

20-5.03E(1)(a) Summary

Section 20-5.03E includes specifications for placing wood mulch.

20-5.03E(1)(b) Definitions

Reserved

20-5.03E(1)(c) Submittals

Submit a certificate of compliance for mulch.

Submit a 2 cu ft mulch sample with the mulch source listed on the bag and obtain approval before delivery of mulch to the job site.

20-5.03E(1)(d) Quality Control and Assurance

Reserved

20-5.03E(2) Materials

20-5.03E(2)(a) General

Mulch must not contain more than 0.1 percent of deleterious materials such as rocks, glass, plastics, metals, clods, weeds, weed seeds, coarse objects, sticks larger than the specified particle size, salts, paint, petroleum products, pesticides or other chemical residues harmful to plant or animal life.

Do not use filter fabric.

20-5.03E(2)(b) Tree Bark Mulch

Tree bark mulch must be derived from cedar, Douglas fir, or redwood species.

Tree bark mulch must be ground so that at least 95 percent of the material by volume is less than 2 inches and no more than 30 percent by volume is less than 1 inch.

20-5.03E(2)(c) Wood Chip Mulch

Wood chip mulch must:

1. Be derived from clean wood
2. Not contain leaves or small twigs
3. Contain at least 95 percent wood chips by volume with average thickness of 1/16 to 3/8 inch in any direction and 1/2 to 3 inches in length

20-5.03E(2)(d) Shredded Bark Mulch

Shredded bark mulch must:

1. Be derived from trees
2. Be a blend of loose, long, thin wood, or bark pieces
3. Contain at least 95 percent wood strands by volume with average thickness of 1/8 to 1-1/2 inches in any direction and 2 to 8 inches in length

20-5.03E(2)(e) Tree Trimming Mulch

Tree trimming mulch must:

1. Be derived from chipped trees and may contain leaves and small twigs.
2. Contain at least 95 percent material by volume less than 3 inches and no more than 30 percent by volume less than 1 inch

20-5.03E(2)(f)–20-5.03E(2)(j) Reserved

20-5.03E(3) Construction

Spread mulch placed in areas outside of plant basins to a uniform thickness as shown.

Mulch must be placed at the rate described and placed in the plant basins or spread in areas as shown after the plants have been planted. Mulch placed in plant basins must not come in contact with the plant crown and stem.

Spread mulch from the outside edge of the proposed plant basin or plant without basin to the adjacent edges of shoulders, paving, retaining walls, dikes, edging, curbs, sidewalks, walls, fences, and existing plantings. If the proposed plant or plant without basin is 12 feet or more from the adjacent edges of shoulders, paving, retaining walls, dikes, edging, curbs, sidewalks, walls, fences, and existing plantings, spread the mulch 6 feet beyond the outside edge of the proposed plant basin or plant without basin.

Do not place mulch within 4 feet of:

1. Flow line of earthen drainage ditches
2. Edge of paved ditches
3. Drainage flow lines

20-5.03E(4) Payment

Mulch is measured in the vehicle at the point of delivery.

20-5.03F–20-5.03J Reserved

20-5.04 RESERVED

Reserved

20-5.05 SITE FURNISHINGS

20-5.05A General

Section 20-5.05 includes specifications for installing site furnishings.

20-5.05B–20-5.05Z Reserved

20-5.06–20-5.10 RESERVED

AA

21 EROSION CONTROL

07-19-13

Replace ", bonded fiber matrix, and polymer-stabilized fiber matrix" in the 1st paragraph of section 21-1.01B with:

04-20-12

and bonded fiber matrix

04-20-12

Delete the last paragraph of section 21-1.02E.

Replace section 21-1.02F(2) with:

04-20-12

21-1.02F(2) Reserved

Replace "20-7.02D(1)" in the 1st paragraph of section 21-1.02H with:

07-19-13

20-3.01B(4)

Replace section 21-1.02J with:

04-20-12

21-1.02J Reserved

Replace the row for organic matter content in the table in the 4th paragraph of section 21-1.02M with:

01-18-13

Organic matter content	TMECC 05.07-A	30–100
	Loss-on-ignition organic matter method (LOI) % dry weight basis	

Replace the paragraph in section 21-1.02P with:

10-19-12

Fiber roll must be a premanufactured roll filled with rice or wheat straw, wood excelsior, or coconut fiber. Fiber roll must be covered with biodegradable jute, sisal, or coir fiber netting secured tightly at each end and must be one of the following:

1. 8 to 10 inches in diameter and at least 1.1 lb/ft
2. 10 to 12 inches in diameter and at least 3 lb/ft

Fiber roll must have a minimum functional longevity of 1 year.

Replace section 28-2 with:

07-19-13

28-2 LEAN CONCRETE BASE

28-2.01 GENERAL

28-2.01A Summary

Section 28-2 includes specifications for constructing lean concrete base (LCB).

28-2.01B Definitions

coarse aggregate: Aggregate retained on a no. 4 sieve.

fine aggregate: Aggregate passing a no. 4 sieve.

28-2.01C Submittals

28-2.01C(1) General

At least 25 days before field qualification, submit the name of your proposed testing laboratory.

At least 10 days before field qualification, submit:

1. Aggregate qualification test results
2. Proposed aggregate gradation
3. Mix design, including:
 - 3.1. Proportions
 - 3.2. Types and amounts of chemical admixtures
4. Optional notice stating intent to produce LCB qualifying for a transverse contraction joint waiver under section 28-2.03D

Submittals for cementitious material must comply with section 90-1.01C(3).

Submit QC test results within 24 hours of test completion.

28-2.01C(2) Field Qualification

11-15-13

For each field qualification for each mix design, manufacture 12 specimens under ASTM C 31 and submit six of the specimens from 24 to 72 hours after manufacture. Use one batch for all 12 specimens.

07-19-13

Submit field qualification data and test reports including:

1. Mixing date
2. Mixing equipment and procedures used
3. Batch volume in cu yd, the minimum is 5 cu yd
4. Type and source of ingredients used
5. Age and strength from compression strength results

Field qualification test reports must be signed by the official in responsible charge of the laboratory performing the tests.

28-2.01D Quality Control and Assurance

28-2.01D(1) General

Stop LCB activities and immediately notify the Engineer whenever:

1. Any quality control or acceptance test result does not comply with the specifications
2. Visual inspection shows noncompliant LCB

If LCB activities are stopped, before resuming activities:

1. Inform the Engineer of the adjustments you will make
2. Remedy or replace the noncompliant LCB
3. Obtain authorization

Molds for compressive strength testing under ASTM C 31 or ASTM C 192 must be 6 by 12 inches.

Quality control and assurance for cementitious materials and admixtures must comply with section 90-1.01D(1)

28-2.01D(2) Aggregate Qualification Testing

Qualify the aggregate for each proposed aggregate source and gradation. Qualification tests include (1) sand equivalent and (2) average 7-day compressive strength under ASTM C 39 on 3 specimens manufactured under ASTM C 192. The cement content for this test must be 300 lb/cu yd, and the 7-day average compressive strength must be at least 610 psi. Cement must be Type II portland cement under section 90-1.02B(2).

LCB must have from 3 to 4 percent air content during aggregate qualification testing.

28-2.01D(3) Field Qualification Testing

Before placing LCB, you must perform field qualification testing and obtain authorization for each mix design. Retest and obtain authorization for changes to authorized mixed designs.

Proposed mix designs must be field qualified before you place the LCB represented by those mix designs. Use an American Concrete Institute (ACI) certified "Concrete Laboratory Technician, Grade I" to perform field qualification tests and calculations.

Notify the Engineer at least 5 days before field qualification. Perform field qualification within the job site or a location authorized by the Engineer.

Field qualification testing includes compressive strength, air content, and penetration or slump in compliance with the table titled "Quality Control Requirements."

Field qualification testing for compressive strength must comply with the following:

1. Manufacture 12 cylinders under ASTM C 31 from a single batch
2. Perform 3 tests; each test consists of determining the average compressive strength of 2 cylinders at 7 days under ASTM C 39
3. The average compressive strength for each test must be at least 530 psi

If you submitted a notice to produce LCB qualifying for a transverse contraction joint waiver, manufacture additional specimens and test LCB for compressive strength at 3 days. Prepare compressive strength cylinders under ASTM C 31 at the same time using the same material and procedures as the 7-day

compressive strength cylinders except do not submit 6 additional test cylinders. The average 3-day compressive strength for each test must be not more than 500 psi.

28-2.01D(4) Quality Control Testing

Provide a testing laboratory to perform quality control tests. Maintain sampling and testing equipment in proper working condition. Perform sampling under California Test 125.

Testing laboratories and testing equipment must comply with the Department's Independent Assurance Program.

Perform quality control sampling, testing, and inspection throughout LCB production and placement. LCB must comply with the requirements for the quality characteristics shown in the following table:

Quality Control Requirements

Quality characteristic	Test method	Minimum sampling and testing frequency	Requirement
Sand equivalent (min)	ASTM D 2419	1 per 500 cubic yards but at least 1 per day of production	18
Aggregate gradation	ASTM C 136		Note a
Air content (max, percent) ^b	ASTM C 231		4
Penetration (inches)	ASTM C 360		0 to 1-1/2 nominal ^{c, d}
Slump (inches)	ASTM C 143		0-3 nominal ^{c, d}
Compressive strength (min, psi at 7 days)	ASTM C 39 ^e		530
Compressive strength (max, psi at 3 days) ^f	ASTM C 39 ^e		500

^a Comply with the table titled "Aggregate Grading" in section 28-2.02C.

^b If no single test in the first 5 air content tests exceeds 1-1/2 percent, no further air content tests are required.

^c Maximum penetration must not exceed 2 inches and maximum slump must not exceed 4 inches

^d Test for either penetration or slump

^e Prepare cylinders under ASTM C 31

^f Only applicable if you (1) submitted a notice stating intent to produce LCB qualifying for a transverse contraction joint waiver and (2) successfully field qualified the LCB for 3-day compressive strength. Make cylinders at the same time using the same material and procedures as QC testing for 7-day compressive strength.

28-2.01D(5) Acceptance Criteria

For acceptance, properties of LCB must comply with values shown in the following table:

Acceptance Criteria Testing

Property	Test method	Value
Compressive strength (min, psi at 7 days)	ASTM C 39 ^a	530 ^b

^a Cylinders prepared under ASTM C 31

^b A compressive strength test represents up to (1) 1,000 cu yd or (2) 1 day's production if less than 1,000 cu yd.

28-2.02 MATERIALS

28-2.02A General

Water must comply with section 90-1.02D.

The air content in LCB must not exceed 4 percent. If the aggregate used for LCB is produced from processed reclaimed asphalt concrete or other material that may cause the air content to exceed 4 percent, reduce the air content with an admixture.

A water-reducing chemical admixture may be used. Water-reducing chemical admixture must comply with ASTM C 494, Type A or Type F.

Air-entraining admixtures must comply with section 90-1.02E.

28-2.02B Cementitious Material

Portland cement must comply with section 90-1.02B. Portland cement content must not exceed 300 lb/cu yd.

SCM must comply with section 90-1.02B except the equations for SCM content under 90-1.02B(3) do not apply.

For aggregate qualification testing, use Type II portland cement under section 90-1.02B(2) without SCM.

28-2.02C Aggregate

Aggregate must be clean and free from decomposed material, organic material, and other deleterious substances. Aggregate samples must not be treated with lime, cement, or chemicals before testing for sand equivalent.

Use either 1-1/2 inch or 1 inch grading. Do not change your selected aggregate grading without authorization.

When tested under ASTM C 136, the percentage composition by weight of the aggregate must comply with the grading requirements for the sieve sizes shown in the following table:

Aggregate Grading

Sieve sizes	Percentage passing			
	1-1/2" maximum		1" maximum	
	Operating range	Contract compliance	Operating range	Contract compliance
2"	100	100	--	--
1-1/2"	90-100	87-100	100	100
1"	--	--	90-100	87-100
3/4"	50-85	45-90	50-100	45-100
3/8"	40-75	35-80	40-75	35-80
No. 4	25-60	20-65	35-60	30-65
No. 30	10-30	6-34	10-30	6-34
No. 200	0-12	0-15	0-12	0-15

Aggregate must comply with the quality requirements shown in the following table:

Aggregate Quality

Property	Test Method	Operating range	Contract compliance
Sand equivalent (min)	ASTM D 2419	21	18
Compressive strength (min, psi at 7 days)	ASTM C 192 ASTM C 39	--	610 at 300 lb/cu yd cement content

Note: Cement must be Type II portland cement under section 90-1.02B(2).

If the aggregate grading or the sand equivalent test results, or both comply with contract compliance requirements but not operating range requirements, you may continue placing LCB for the remainder of the work day. Do not place additional LCB until you demonstrate the LCB to be placed complies with the operating range requirements.

28-2.03 CONSTRUCTION

28-2.03A General

Do not allow traffic or equipment on the LCB for at least 72 hours after the 1st application of the curing compound and completion of contraction joints. Limit traffic and equipment on the LCB to that is required for placing additional layers of LCB or paving.

28-2.03B Subgrade

Immediately before spreading LCB, the subgrade must:

1. Comply with the specified compaction and elevation tolerance for the material involved
2. Be free from loose or extraneous material
3. Be uniformly moist

Areas of subgrade lower than the grade established by the Engineer must be filled with LCB. The Department does not pay for filling low areas of subgrade.

28-2.03C Proportioning, Mixing, and Transporting

Proportion LCB under section 90-1.02F except aggregate does not have to be separated into sizes.

Mix and transport LCB under section 90-1.02G except the 5th and 7th paragraphs in section 90-1.02G(6) do not apply.

28-2.03D Placing

Place LCB under section 40-1.03H(1) except the 3rd paragraph does not apply.

Unless otherwise described, construct LCB in minimum widths of 12 feet separated by construction joints. For LCB constructed monolithically in widths greater than 26 feet, construct a longitudinal contraction joint offset no more than 3 feet from the centerline of the width being constructed.

Contraction joints must comply with section 40-1.03D(3).

Construct transverse contraction joints in intervals that result in LCB areas where the lengths and widths are within 20 percent of each other. Measure the widths from any longitudinal construction or longitudinal contraction joints.

The Engineer waives the requirement for transverse contraction joints if you:

1. Submitted a notice under 28-2.01C(1)
2. Successfully field qualified LCB for 3-day compressive strength testing
3. Submit QC test results for 3-day compressive strength under section 28-2.01D(4).

If concrete pavement will be placed on LCB, construct longitudinal construction and longitudinal contraction joints in the LCB. Provide at least 1 foot horizontal clearance from planned longitudinal construction and longitudinal contraction joints in the concrete pavement.

Do not mix or place LCB when the atmospheric temperature is below 35 degrees F. Do not place LCB on frozen ground.

28-2.03E Finishing

Place LCB under section 40-1.03H(4) or under section 40-1.03H(5) except where there are confined work areas and when authorized:

1. Spread and shape LCB using suitable powered finishing machines and supplement with hand work as necessary
2. Consolidate LCB using high-frequency internal vibrators within 15 minutes after LCB is deposited on the subgrade
3. Vibrate with care such that adequate consolidation occurs across the full paving width and do not use vibrators for extensive weight shifting of the LCB

For LCB to be paved with HMA, before curing operation texture the LCB finished surface by dragging a broom, burlap, or a spring steel tine device. If using a spring steel tine device, the device must produce a scored surface with scores parallel or transverse to the pavement centerline. Texture at a time and in a manner that produces the coarsest texture for the method used.

For LCB to be paved with HMA, the finished surface must not vary more than 0.05 foot from the grade established by the Engineer.

Do not texture LCB that will be covered with concrete pavement. Before applying curing compound, finish LCB to a smooth surface free from mortar ridges and other projections.

For LCB to be paved with concrete pavement, the finished surface must not be above the grade, or more than 0.05 foot below the grade established by the Engineer.

The finished surface must be free from porous areas.

28-2.03F Curing

After finishing LCB, cure LCB with pigmented curing compound under section 90-1.03B(3) and 40-1.03K except for LCB to be paved with concrete pavement, comply with section 36-2. Apply curing compound to the area to be paved with concrete pavement:

1. In 2 separate applications
2. Before the atmospheric temperature falls below 40 degrees F
3. At a rate of 1 gal/150 sq ft for the first application
4. At a rate of 1 gal/200 sq ft for the second application. Within 4 days after the first application, clean the surface and apply the second application.

Immediately repair damage to the curing compound or LCB.

28-2.03G Surfaces Not Within Tolerance

Where LCB will be paved with concrete pavement, remove the base wherever the surface is higher than the grade established by the Engineer and replace it with LCB. Where LCB will not be paved with concrete pavement, remove the base wherever the surface is higher than 0.05 foot above the grade established by the Engineer and replace it with LCB. If authorized, grind the surface with either a diamond or carborundum blade to within tolerance. After grinding LCB to be paved with concrete pavement and after all free water has left the surface, clean foreign material and grinding residue from the surface. Apply curing compound to the ground area at a rate of approximately 1 gal/150 sq ft.

Where the surface of LCB is lower than 0.05 foot from the grade established by the Engineer, remove the base and replace it with LCB or, if authorized, fill low areas according to the pavement material as follows:

1. For HMA pavement, fill low areas with HMA that complies with the specifications for the lowest layer of pavement. Do not fill low areas concurrently with the paving operation.
2. For concrete pavement, fill low areas with pavement concrete concurrent with the paving operation.

28-2.04 PAYMENT

LCB is measured from the dimensions shown.

Replace section 28-3 with:

07-19-13

28-3 RAPID STRENGTH CONCRETE BASE

Reserved

Replace section 28-4 with:

07-19-13

28-4 LEAN CONCRETE BASE RAPID SETTING

Reserved

37 BITUMINOUS SEALS

03-21-14

Replace section 37-1.01 with:

01-18-13

37-1.01 GENERAL

37-1.01A Summary

Section 37-1 includes general specifications for applying bituminous seals.

37-1.01B Definitions

Reserved

37-1.01C Submittals

Reserved

37-1.01D Quality Control and Assurance

37-1.01D(1) General

Reserved

37-1.01D(2) Prepaving Conference

For seal coats and micro-surfacing, schedule a prepaving conference at a mutually agreed upon time and place to meet with the Engineer.

Prepaving conference attendees must sign an attendance sheet provided by the Engineer. The prepaving conference must be attended by your:

1. Project superintendent
2. Paving construction foreman
3. Traffic control foreman

Be prepared to discuss:

1. Quality control
2. Acceptance testing
3. Placement
4. Training on placement methods
5. Checklist of items for proper placement
6. Unique issues specific to the project, including:
 - 6.1. Weather
 - 6.2. Alignment and geometrics
 - 6.3. Traffic control issues
 - 6.4. Haul distances
 - 6.5. Presence and absence of shaded areas
 - 6.6. Any other local issues

37-1.02 MATERIALS

Not Used

37-1.03 CONSTRUCTION

Not Used

37-1.04 PAYMENT

Not Used

Replace section 37-2 with:

07-19-13

37-2 SEAL COATS

37-2.01 GENERAL

37-2.01A General

37-2.01A(1) Summary

Section 37-2 includes specifications for applying seal coats.

37-2.01A(2) Definitions

Reserved

37-2.01A(3) Submittals

Reserved

37-2.01A(4) Quality Control and Assurance

The following personnel must attend the prepaving conference:

1. Aggregate suppliers
2. Chip spreader operators
3. Emulsion and binder distributor
4. Coated chips producer if coated chips are used

37-2.01B Materials

Screenings must be broken stone, crushed gravel, or both. At least 90 percent of screenings by weight must be crushed particles as determined under California Test 205.

Screenings for seal coats must have the properties specified in the following table:

Seal Coat Screenings

Properties	Test method	Specification
Los Angeles Rattler, %, max	California Test 211	
Loss at 100 revolutions.		10
Loss at 500 revolutions.		40
Film stripping, %, max	California Test 302	25

37-2.01C Construction

37-2.01C(1) General

Wherever final sweeping or brooming of the seal coat surface is complete, place permanent traffic stripes and pavement markings within 10 days.

If you fail to place the permanent traffic stripes and pavement markings within the specified time, the Department withholds 50 percent of the estimated value of the seal coat work completed that has not received permanent traffic stripes and pavement markings.

37-2.01C(2) Equipment

Equipment for seal coats must include and comply with the following:

1. Screenings haul trucks. Haul trucks must have:
 - 1.1. Tailgates that discharge screenings
 - 1.2. Devices to lock onto the rear screenings spreader hitch
 - 1.3. Dump beds that will not push down on the spreader when fully raised
 - 1.4. Dump beds that will not spill screenings on the roadway when transferred to the spreader hopper
 - 1.5. Tarpaulins to cover precoated screenings when haul distance exceeds 30 minutes or ambient temperature is less than 65 degrees F
2. Self-propelled screenings spreader. The spreader must have:
 - 2.1. Screenings hopper in the rear
 - 2.2. Belt conveyors that carry the screenings to the front
 - 2.3. Spreading hopper capable of providing a uniform screening spread rate over the entire width of the traffic lane in 1 application.
3. Self-propelled power brooms. Do not use gutter brooms or steel-tined brooms. Brooms must be capable of removing loose screenings adjacent to barriers that prevent screenings from being swept off the roadway, including curbs, gutters, dikes, berms, and railings.
4. Pneumatic-tired rollers. Pneumatic-tired rollers must be an oscillating type at least 4 feet wide. Each roller must be self-propelled and reversible. Pneumatic tires must be of equal size, diameter, type, and ply. The roller must carry at least 3,000 lb of load on each wheel and each tire must have an air pressure of 100 ± 5 psi.

37-2.01C(3) Surface Preparation

Before applying seal coat, cover manholes, valve and monument covers, grates, or other exposed facilities located within the area of application, using a plastic or oil resistant construction paper secured by tape or adhesive to the facility being covered. Reference the covered facilities with a sufficient number of control points to relocate the facilities after the application of the seal coat.

After completion of the seal coat operation, remove covers from the facilities.

Immediately before applying seal coat, clean the surface to receive seal coat by removing extraneous material and drying. Cleaning the existing pavement includes the use of brooms.

37-2.01C(4) Applying Emulsion and Asphalt Binder

Prevent spray on existing pavement not intended for seal coat or on previously applied seal coat using a material such as building paper. Remove the material after use.

Align longitudinal joints between seal coat applications with designated traffic lanes.

For emulsion, overlap longitudinal joints by not more than 4 inches. You may overlap longitudinal joints up to 8 inches if authorized.

For areas not accessible to a truck distributor bar, apply the emulsion with a squeegee or other authorized means. For asphalt binder, hand spray nonaccessible areas. You may overlap the emulsion or asphalt binder applications before the application of screenings at longitudinal joints.

Do not apply the emulsion or asphalt binder unless there are sufficient screenings at the job site to cover the emulsion or asphalt binder.

Discontinue application of emulsion or asphalt binder early enough to comply with lane closure specifications and darkness. Apply to 1 lane at a time and cover the lane entirely in 1 operation.

37-2.01C(5) Spreading Screenings

Prevent vehicles from driving on asphaltic emulsion or asphalt binder before spreading screenings.

Spread screenings at a uniform rate over the full lane width in 1 application.

Broom excess screenings at joints before spreading adjacent screenings.

Operate the spreader at speeds slow enough to prevent screenings from rolling over after dropping.

If the spreader is not moving, screenings must not drop. If you stop spreading and screenings drop, remove the excess screenings before resuming activities.

37-2.01C(6) Finishing

Remove piles, ridges, or unevenly distributed screenings. Repair permanent ridges, bumps, or depressions in the finished surface. Spread additional screenings and roll if screenings are picked up by rollers or vehicles.

Seal coat joints between adjacent applications of seal coat must be smooth, straight, uniform, and completely covered. Longitudinal joints must be at lane lines and not overlap by more than 4 inches. Blend the adjacent applications by brooming.

A coverage is the number of passes a roller needs to cover the width. A pass is 1 roller movement parallel to the seal coat application in either direction. Overlapping passes are part of the coverage being made and are not part of a subsequent coverage. Do not start a coverage until completing the previous coverage.

Before opening to traffic, finish seal coat in the following sequence:

1. Perform initial rolling consisting of 1 coverage with a pneumatic-tired roller
2. Perform final rolling consisting of 3 coverages with a pneumatic-tired roller
3. Broom excess screenings from the roadway and adjacent abutting areas
4. Apply flush coat if specified

The Engineer may order salvaging of excess screenings.

Dispose of excess screenings the Engineer determines are not salvageable. Dispose of screenings in any of the following ways or locations:

1. Under section 14-10
2. On embankment slopes
3. In authorized areas

Salvaging and stockpiling excess screenings is change order work.

37-2.01C(7) Seal Coat Maintenance

Seals coat surfaces must be maintained for 4 consecutive days from the day screenings are applied. Maintenance must include brooming to maintain a surface free of loose screenings, to distribute screenings over the surface so as to absorb any free asphaltic material, to cover any areas deficient in cover coat material, and to prevent formation of corrugations.

After 4 consecutive days, excess screenings must be removed from the paved areas. Brooming must not displace screenings set in asphaltic material.

The exact time of brooming will be determined by the Engineer. As a minimum, brooming will be required at the following times:

1. On 2-lane 2-way roadways, from 2 to 4 hours after traffic, controlled with pilot cars, has been routed on the seal coat
2. On multilane roadways, from 2 to 4 hours after screenings have been placed
3. In addition to previous brooming, immediately before opening any lane to public traffic, not controlled with pilot cars
4. On the morning following the application of screenings on any lane that has been open to public traffic not controlled with pilot cars and before starting any other activities

For 2-lane 2-way roadways under 1-way traffic control, upon completion of secondary rolling, public traffic must be controlled with pilot cars and routed over the new seal coat for a period of 2 to 4 hours. The Engineer will determine the exact period of time.

Schedule the operations so that seal coat is placed on both lanes of the traveled way each work shift and so that 1-way traffic control is discontinued 1 hour before darkness. At the end of the work shift, the end of the seal coat on both lanes must generally match.

On multilane roadways, initial brooming must begin after the screenings have been in place for a period of 2 to 4 hours. If the initial brooming is not completed during the work shift in which the screenings were placed, the initial brooming must be completed at the beginning of the next work shift.

Public traffic must be controlled with pilot cars and be routed on the new seal coat surface of the lane for a minimum of 2 hours after completion of the initial brooming and before opening the lane to traffic not controlled with pilot cars. When traffic is controlled with pilot cars, a maximum of 1 lane in the direction of travel must be open to public traffic. Once traffic controlled with pilot cars is routed over the seal coat at a particular location, continuous control must be maintained at that location until the seal coat placement and brooming on adjacent lanes to receive seal coat is completed.

37-2.01D Payment

If there is no bid item for a traffic control system, furnishing and using a pilot car is included in the various items of the work involved in applying the seal coat.

If test results for the screenings grading do not comply with specifications, you may remove the seal coat represented by these tests or request that it remain in place with a payment deduction. The deduction is \$1.75 per ton for the screenings represented by the test results.

37-2.02 FOG SEAL

37-2.02A General

37-2.02A(1) Summary

Fog seal coat includes applying a slow-setting asphaltic emulsion.

37-2.02A(2) Definitions

Reserved

37-2.02A(3) Submittals

Submit a 1/2-gallon sample of the asphaltic emulsion in a plastic container. Take the sample from the distributor truck spray bar at mid-load.

37-2.02A(4) Quality Control and Assurance

Reserved

37-2.02B Material

The Engineer selects the grade of slow-setting asphaltic emulsion to be used.

If additional water is added to the asphaltic emulsion, the resultant mixture must not be more than 1 part asphaltic emulsion to 1 part water. The Engineer determines the exact amount of additional water.

37-2.02C Construction

Apply asphaltic emulsion for fog seal coat at a residual asphalt rate from 0.02 to 0.06 gal/sq yd. The Engineer determines the exact rate.

Apply fog seal coat when the ambient air temperature is above 40 degrees F.

Sprinkle water on fog seal coat that becomes tacky in an amount determined by the Engineer.

If fog seal coat and seal coat with screenings are specified on the same project, apply fog seal coat at least 4 days before applying the adjoining seal coat with screenings. The joint between the seal coats must be neat and uniform.

37-2.02D Payment

The Department does not adjust the unit price for an increase or decrease in the asphaltic emulsion (fog seal coat) quantity.

37-2.03 FLUSH COATS

37-2.03A General

03-21-14

Flush coat includes applying a fog seal coat to the surface, followed by sand.

07-19-13

37-2.03B Material

The Engineer selects the grade of slow-setting or quick-setting asphaltic emulsion to be used.

Sand for flush coat must comply with the material specifications for fine aggregate grading in section 90-1.02C(3). Sand must not include organic material or clay.

37-2.03C Construction

Apply asphaltic emulsion for flush coat at a residual asphalt rate from 0.02 to 0.06 gal/sq yd. The Engineer determines the exact rate.

During flush coat activities, close adjacent lanes to traffic. Do not track asphaltic emulsion on existing pavement surfaces.

Apply sand immediately after the asphaltic emulsion application.

Spread sand with a self-propelled screenings spreader equipped with a mechanical device that spreads sand at a uniform rate over the full width of a traffic lane in a single application. Spread sand at a rate from 2 to 6 lb/sq yd. The Engineer determines the exact rate.

37-2.03D Payment

The Department does not adjust the unit price for an increase or decrease in the sand cover for the flush coat quantity.

37-2.04 ASPHALTIC EMULSION SEAL COAT

37-2.04A General

37-2.04A(1) General

37-2.04A(1)(a) Summary

Section 37-2.04 includes specifications for applying asphaltic emulsion seal coat. Asphaltic emulsion seal coat includes applying asphaltic emulsion, followed by screenings, and then a flush coat.

Asphaltic emulsion seal coat includes one or more of the following types:

1. Nonpolymer asphaltic emulsion seal coat
2. Polymer asphaltic emulsion seal coat

A double asphaltic emulsion seal coat is the application of asphaltic emulsion, followed by screenings applied twice in sequence.

37-2.04A(1)(b) Definitions

Reserved

37-2.04A(1)(c) Submittals

At least 10 days before starting asphaltic emulsion seal coat application, submit the name of an authorized laboratory that will be performing asphaltic emulsion QC testing.

03-21-14

Submit a sample of asphaltic emulsion in a 1/2-gallon plastic container to the Engineer and to the authorized laboratory. Each sample must be submitted in an insulated shipping container within 24 hours of sampling.

07-19-13

Within 7 days after taking samples, submit the authorized laboratory's test results for asphaltic emulsion.

37-2.04A(1)(d) Quality Control and Assurance

Samples for the screenings grading and cleanness value must be taken from the spreader conveyor belt.

03-21-14

Within 3 business days of sampling, the authorized laboratory must test the asphaltic emulsion for:

1. Viscosity under AASHTO T 59
2. Sieve test under AASHTO T 59
3. Demulsibility under AASHTO T 59
4. Torsional recovery under California Test 332 for polymer asphaltic emulsion
5. Elastic recovery under AASHTO T 301 for polymer asphaltic emulsion

Circulate asphaltic emulsion in the distributor truck before sampling. Take samples from the distributor truck at mid load or from a sampling tap or thief. Before taking samples, draw and dispose of 1 gallon. In the presence of the Engineer take two 1/2-gallon samples every 55 tons or at least 1 day's production.

07-19-13

37-2.04A(2) Materials

Not Used

37-2.04A(3) Construction

The Engineer determines the exact application rate.

At the time of application, the temperature of the asphaltic emulsion must be from 130 to 180 degrees F.

When tested under California Test 339, the application rate for asphaltic emulsion must not vary from the average by more than:

1. 15 percent in the transverse direction
2. 10 percent in the longitudinal direction

37-2.04A(4) Payment

Not Used

37-2.04B Nonpolymer Asphaltic Emulsion Seal Coat

37-2.04B(1) General

37-2.04B(1)(a) Summary

Section 37-2.04B includes specifications for applying a nonpolymer asphaltic emulsion seal coat.

37-2.04B(1)(b) Definitions

Reserved

37-2.04B(1)(c) Submittals

Reserved

37-2.04B(1)(d) Quality Control and Assurance

For nonpolymer asphaltic emulsion seal coat, if a test result for the screenings cleanness value is from 75 to 80, you may request that the asphaltic emulsion seal coat represented by the test remain in place. A payment deduction is made as specified in section 37-2.04D. If the screenings cleanness value is less than 75, remove the asphaltic emulsion seal coat.

37-2.04B(2) Materials

Screenings for nonpolymer asphaltic emulsion seal coat must have the gradation as determined under California Test 202 in the following table.

**Nonpolymer Asphaltic Emulsion Seal Coat Screenings
Gradation**

Sieve sizes	Percentage passing			
	Coarse 1/2" max	Medium 3/8" max	Medium fine 5/16" max	Fine 1/4" max
3/4"	100	--	--	--
1/2"	95–100	100	--	--
3/8"	50–80	90–100	100	100
No. 4	0–15	5–30	30–60	60–85
No. 8	0–5	0–10	0–15	0–25
No. 16	--	0–5	0–5	0–5
No. 30	--	--	0–3	0–3
No. 200	0–2	0–2	0–2	0–2

03-21-14

The cleanness value determined under California Test 227 must be 80 or greater.

07-19-13

37-2.04B(3) Construction

Asphaltic emulsion must be applied within the application rate ranges shown in the following table:

Asphaltic Emulsion Application Rates

Screenings	Application rate range(gallons per square yard)
Fine	0.15–0.30
Medium fine	0.25–0.35
Medium	0.25–0.40
Coarse	0.30–0.40

Apply asphaltic emulsion when the ambient air temperature is from 65 to 110 degrees F and the pavement surface temperature is at least 80 degrees F.

Do not apply asphaltic emulsion when weather forecasts predict the ambient air temperature will fall below 39 degrees F within 24 hours after application.

For double asphaltic emulsion seal coat, the asphaltic emulsion must be applied within the application rates shown in the following table:

Asphaltic Emulsion Application Rates

Screenings	Application rate range (gal/sq yd)
Double	
1st application	0.20–0.35
2nd application	0.20–0.30

You may stockpile screenings for asphaltic emulsion seal coat if you prevent contamination. Screenings must have damp surfaces at spreading. If water visibly separates from the screenings, do not spread. You may redampen them in the delivery vehicle.

Spread screenings before the asphaltic emulsion sets or breaks.

Spread screenings within 10 percent of the rate determined by the Engineer. Screenings must have a spread rate within the ranges shown in the following table:

Screening Spread Rates

Seal coat type	Range (lb/sq yd)
Fine	12–20
Medium fine	16–25
Medium	20–30
Coarse	23–30

Do not spread screenings more than 2,500 feet ahead of the completed initial rolling.

For double asphaltic emulsion seal coat, screenings must have a spread rate within the ranges shown in the following table:

Screening Spread Rates

Seal coat type	Range (lb/sq yd)
Double	
1st application	23–30
2nd application	12–20

Remove excess screenings on the 1st application before the 2nd application of asphaltic emulsion.

37-2.04B(4) Payment

If asphaltic emulsion seal coat with screenings does not comply with the cleanness value specifications, you may request that the seal coat remain in place with a pay deduction corresponding to the cleanness value shown in the following table:

Asphaltic Emulsion Seal Coat Cleanness Value Deductions

Cleanness value	Deduction
80 or over	None
79	\$2.00 /ton
77-78	\$4.00 /ton
75-76	\$6.00 /ton

37-2.04C Polymer Asphaltic Emulsion Seal Coat

37-2.04C(1) General

37-2.04C(1)(a) Summary

Section 37-2.04C includes specifications for applying a polymer asphaltic emulsion seal coat.

37-2.04C(1)(b) Definitions

Reserved

37-2.04C(1)(c) Submittals

At least 10 days before starting polymer asphaltic emulsion seal coat application, submit a signed copy of the test result report of the Vialit test method for aggregate retention in chip seals (french chip) to the Engineer and to:

DEPARTMENT OF TRANSPORTATION

Division of Maintenance, Roadway Maintenance Office

1120 N Street, MS 31

Sacramento, CA 95814

37-2.04C(1)(d) Quality Control and Assurance

The authorized laboratory must test screenings for retention under the Vialit test method for aggregate in chip seals (french chip). The Vialit test results are not used for acceptance. The Vialit test is available at the METS Web site.

If the test results for polymer asphaltic emulsion do not comply with the specifications, the Engineer assesses a pay factor value for the following properties and increments:

Polymer Asphaltic Emulsion Pay Factor Table

Test method and property	Increment	Pay factor
Test on polymer asphaltic emulsion		
AASHTO T 59 (Viscosity, sec Saybolt Furol, at 50 °C)	Each 10 seconds above max or below min	1
AASHTO T 59 (settlement, 5 days, percent)	Each 1.5 percent above max	1
AASHTO T 59 (sieve test, percent max)	Each 0.2 percent above max	1
AASHTO T 59 (demulsibility percent)	Each 2 percent below min	1
Test on residue from evaporation test		
AASHTO T 49 (penetration, 25 °C)	Each 2 dm above max or below min	1
ASTM D 36 (field softening point °C)	2 °C below min	1
California Test 332 (torsional recovery ^a)	For each 1 increment below the min value of 18	1
	For each 2 increments below the min value of 18	3
	For each 3 or more increments below the min value of 18	10
ASTM T 301 (elastic recovery ^a)	For each 1 increment below the min value of 60	1
	For each 2 increment below the min value of 60	3
	For each 3 increment below the min value of 60	10

^a The highest pay factor applies

07-19-13

The Engineer assesses a pay factor of 1 for sampling not performed in compliance with the specifications, including shipping and sampling containers.

For polymer asphaltic emulsion seal coat, if a test result for the screenings cleanness value is from 75 to 86, you may request that the asphaltic emulsion seal coat represented by the test remain in place. A payment deduction is made as specified in section 37-2.04D. If the screenings cleanness value is less than 75, remove the asphaltic emulsion seal coat.

37-2.04C(2) Materials

Polymer asphaltic emulsion must include elastomeric polymer.

03-21-14

Polymer asphaltic emulsion must comply with section 94, Table 3, under the test on residue from evaporation test for Grades PMRS2, PMRS2h, PMCRS2, and PMCRS2h and the following:

1. The penetration at 39.2 degrees F (200g for 60 seconds) determined under AASHTO T 49 must be at least 6.
2. Elastic recovery determined under AASHTO T 301 must be at least 60 percent.
3. Polymer content in percent by weight does not apply.
4. The ring and ball softening point temperature determined under AASHTO T 53 for Test on Residue from Evaporation Test must comply with the following minimum temperature requirement:
 - 4.1. 126 degrees F for a geographical ambient temperature from 32 to 104 degrees F
 - 4.2. 129 degrees F for a geographical ambient temperature from 18 to 104 degrees F
 - 4.3. 135 degrees F for a geographical ambient temperature from 18 to greater than 104 degrees F

07-19-13

Screenings for polymer asphaltic emulsion seal coat must have the gradation as determined under California Test 202 in the following table:

Polymer Asphaltic Emulsion Seal Coat Screenings Gradation

Sieve sizes	Percentage passing			
	Coarse 1/2" max	Medium 3/8" max	Medium fine 5/16" max	Fine 1/4" max
3/4"	100	--	--	--
1/2"	85–100	100	--	--
3/8"	0–30	85–100	100	100
No. 4	0–5	0–15	0–50	60–85
No. 8	--	0–5	0–15	0–25
No. 16	--	--	0–5	0–5
No. 30	--	--	0–3	0–3
No. 200	0–2	0–2	0–2	0–2

03-21-14

The cleanness value determined under California Test 227 must be 86 or greater.

07-19-13

37-2.04C(3) Construction

Polymer asphaltic emulsion must be applied within the application rate ranges shown in the following table:

Polymer Asphaltic Emulsion Application Rates

Screenings	Application rate range(gallons per square yard)
Fine	0.15–0.30
Medium fine	0.25–0.35
Medium	0.25–0.40
Coarse	0.30–0.40

Apply polymer asphaltic emulsion when the ambient air temperature is from 60 to 105 degrees F and the pavement surface temperature is at least 55 degrees F.

Do not apply polymer asphaltic emulsion when weather forecasts predict the ambient air temperature will fall below 39 degrees F within 24 hours after application.

For double asphaltic emulsion seal coat, polymer asphaltic emulsion must be applied within the application rates shown in the following table:

Polymer Asphaltic Emulsion Application Rates

Screenings	Application rate range (gal/sq yd)
Double	
1st application	0.20–0.35
2nd application	0.20–0.30

You may stockpile screenings for polymer emulsion seal coat if you prevent contamination. Screenings must have damp surfaces at spreading. If water visibly separates from the screenings, do not spread. You may redampen them in the delivery vehicle.

Spread screenings before the polymer emulsion sets or breaks.

Spread screenings within 10 percent of the rate determined by the Engineer. Screenings must have a spread rate within the ranges shown in the following table:

Screening Spread Rates

Seal coat type	Range (lb/sq yd)
Fine	12–20
Medium fine	16–25
Medium	20–30
Coarse	23–30

Do not spread screenings more than 2,500 feet ahead of the completed initial rolling.

For double seal coat, screenings must have a spread rate within the ranges shown in the following table:

Screening Spread Rates

Seal coat type	Range (lb/sq yd)
Double	
1st application	23–30
2nd application	12–20

Remove excess screenings on the 1st application before the 2nd application of asphaltic emulsion.

37-2.04C(4) Payment

If polymer asphaltic emulsion seal coat with screenings does not comply with the specifications for cleanness value you may request that the seal coat remain in place with a pay deduction corresponding by the cleanness value shown in the following table:

Polymer Asphaltic Emulsion Seal Coat Cleanness Value Deductions

Cleanness value	Deduction
86 or over	None
81–85	\$2.20/ton
77–80	\$4.40/ton
75–76	\$6.60/ton

If test results for polymer asphaltic emulsion aggregate grading and cleanness value test results do not comply with the specifications, all deductions are made. A test for polymer asphaltic emulsion represents the smaller of 55 tons or 1 day's production. A test for the screenings grading or cleanness value represents the smaller of 300 tons or 1 day's production.

The payment deduction for noncompliant polymer asphaltic emulsion is based on the total pay factor value determined from the table titled, "Polymer Asphaltic Emulsion Pay Factor Deduction." You must remove polymer asphaltic emulsion seal coat with a pay factor value greater than 20. You may request seal coat with noncompliant polymer asphaltic emulsion to remain in place with a pay deduction for the total pay factor value shown in the following table:

Polymer Asphaltic Emulsion Pay Factor Deductions

Total pay factor value	Deduction
0	none
1–2	\$5.00/ton
3–5	\$10.00/ton
6–9	\$15.00/ton
10–14	\$25.00/ton
15–20	\$50.00/ton

37-2.05 ASPHALT BINDER SEAL COATS

37-2.05A General

Reserved

37-2.05B Asphalt Rubber Binder Seal Coats

37-2.05B(1) General

37-2.05B(1)(a) Summary

Section 37-2.05B includes specifications for applying asphalt rubber binder seal coat. Asphalt rubber seal coat includes applying heated asphalt rubber binder, followed by heated screenings precoated with asphalt binder, followed by a flush coat.

37-2.05B(1)(b) Definitions

crumb rubber modifier: Ground or granulated high natural crumb rubber or scrap tire crumb rubber.

descending viscosity reading: Subsequent viscosity reading at least 5 percent lower than the previous viscosity reading.

high natural crumb rubber: Material containing 40 to 48 percent natural rubber.

scrap tire crumb rubber: Any combination of:

1. Automobile tires
2. Truck tires
3. Tire buffing

37-2.05B(1)(c) Submittals

For each delivery of asphalt rubber binder ingredients and asphalt rubber binder to the job site, submit a certificate of compliance and a copy of the specified test results.

Submit MSDS for each asphalt rubber binder ingredient and the asphalt rubber binder.

At least 15 days before use, submit:

1. Four 1-quart cans of mixed asphalt rubber binder
2. Samples of each asphalt rubber binder ingredient
3. Asphalt rubber binder formulation and data as follows:
 - 3.1. For asphalt binder and asphalt modifier submit:
 - 3.1.1. Source and grade of asphalt binder
 - 3.1.2. Source and type of asphalt modifier
 - 3.1.3. Percentage of asphalt modifier by weight of asphalt binder
 - 3.1.4. Percentage of combined asphalt binder and asphalt modifier by weight of asphalt rubber binder
 - 3.1.5. Test results for the specified quality characteristics
 - 3.2. For crumb rubber modifier submit:
 - 3.2.1. Each source and type of scrap tire crumb rubber and high natural rubber
 - 3.2.2. Percentage of scrap tire crumb rubber and high natural rubber by total weight of asphalt rubber binder

- 3.2.3. Test results for the specified quality characteristics
- 3.3. For asphalt rubber binder submit:
 - 3.3.1. Test results for the specified quality characteristics
 - 3.3.2. Minimum reaction time and temperature

At least 5 business days before use, submit the permit issued by the local air quality agency for asphalt rubber binder:

1. Field blending equipment
2. Application equipment

If an air quality permit is not required by the local air quality agency for producing asphalt rubber binder or spray applying asphalt rubber binder, submit verification from the local air quality agency that an air quality permit is not required for this Contract.

Submit a certified volume or weight slip for each delivery of asphalt rubber binder ingredients and asphalt rubber binder.

Submit a certificate of compliance and accuracy verification of test results for viscometers.

When determined by the Engineer, submit notification 15 minutes before each viscosity test or submit a schedule of testing times.

Submit the log of asphalt rubber binder viscosity test results each day of asphalt rubber seal coat work.

37-2.05B(1)(d) Quality Control and Assurance

Equipment used in producing asphalt rubber binder must be permitted for use by the local air quality agency. Equipment used in spreading asphalt rubber binder must be permitted for use by the local air quality agency.

Each asphalt rubber binder ingredient must be sampled and tested for compliance with the specifications by the manufacturer.

Test and submit results at least once per project or the following, whichever frequency is greater:

1. For crumb rubber modifier except for grading, at least once per 250 tons. Samples of scrap tire crumb rubber and high natural crumb rubber must be sampled and tested separately. Test each delivery of crumb rubber modifier for grading.
2. For asphalt binder, test and submit at least once per 200 tons of asphalt binder production.
3. For asphalt modifier, test and submit at least once per 25 tons of asphalt modifier production.

Scrap tire crumb rubber and high natural crumb rubber must be delivered to the asphalt rubber production site in separate bags.

Take viscosity readings of asphalt rubber binder under ASTM D7741 during asphalt rubber binder production. Start taking viscosity readings of samples taken from the reaction vessel at least 45 minutes after adding crumb rubber modifier and continue taking viscosity readings every 30 minutes until 2 consecutive descending viscosity readings have been obtained and the final viscosity meets the specification requirement. After meeting the 2 descending viscosity readings requirement, continue to take viscosity readings hourly and within 15 minutes before use. Log the test results, including time of testing and temperature of the asphalt rubber binder.

37-2.05B(2) Material

37-2.05B(2)(a) General

Reserved

37-2.05B(2)(b) Asphalt Binder

Asphalt binder must comply with the specifications for asphalt binder. Do not modify asphalt binder with polymer.

37-2.05B(2)(c) Asphalt Modifier

Asphalt modifier must be a resinous, high flash point, and aromatic hydrocarbon. Asphalt modifier must have the values for the quality characteristics shown in the following table:

Quality characteristic	Test method	Value
Viscosity, m ² /s (x 10 ⁻⁶) at 100 °C	ASTM D 445	X ± 3 ^a
Flash point, CL.O.C., °C	ASTM D 92	207 min
Molecular analysis		
Asphaltenes, percent by mass	ASTM D 2007	0.1 max
Aromatics, percent by mass	ASTM D 2007	55 min

^a "X" denotes the proposed asphalt modifier viscosity from 19 to 36. A change in "X" requires a new asphalt rubber binder submittal.

37-2.05B(2)(d) Crumb Rubber Modifier

Crumb rubber modifier must be ground or granulated at ambient temperature.

Scrap tire crumb rubber and high natural crumb rubber must be delivered to the asphalt rubber binder production site in separate bags.

Steel and fiber must be separated. If steel and fiber are cryogenically separated, it must occur before grinding and granulating. Cryogenically-produced crumb rubber modifier particles must be large enough to be ground or granulated.

Wire must not be more than 0.01 percent by weight of crumb rubber modifier. Crumb rubber modifier must be free of contaminants except fabric, which must not exceed 0.05 percent by weight of crumb rubber modifier. Method for determining the percent weight of wire and fabric is available under Laboratory Procedure 10 at the following METS Web site:

<http://www.dot.ca.gov/hq/esc/Translab/ofpm/fpmlab.htm>

The length of an individual crumb rubber modifier particle must not exceed 3/16 inch.

Crumb rubber modifier must be dry, free-flowing particles that do not stick together. A maximum of 3 percent calcium carbonate or talc by weight of crumb rubber modifier may be added. Crumb rubber modifier must not cause foaming when combined with the asphalt binder and asphalt modifier.

Specific gravity of crumb rubber modifier must be from 1.1 to 1.2 determined under California Test 208.

When tested under ASTM D 297, crumb rubber modifier must comply with the requirements shown in the following table:

Crumb Rubber Modifier

Quality characteristic	Scrap tire crumb rubber (percent)		High natural rubber (percent)	
	Min	Max	Min	Max
Acetone extract	6.0	16.0	4.0	16.0
Rubber hydrocarbon	42.0	65.0	50.0	--
Natural rubber content	22.0	39.0	40.0	48.0
Carbon black content	28.0	38.0	--	--
Ash content	--	8.0	--	--

Scrap tire crumb rubber must have the gradation shown in the following table:

Scrap Tire Crumb Rubber Gradation

Percentage passing

Sieve size	Gradation limit	Operating range	Contract compliance
No. 8	100	100	100
No. 10	98–100	95–100	90–100
No. 16	45–75	35–85	32–88
No. 30	2–20	2–25	1–30
No. 50	0–6	0–10	0–15
No. 100	0–2	0–5	0–10
No. 200	0	0–2	0–5

High natural crumb rubber must have the gradation shown in the following table:

High Natural Crumb Rubber Gradation

Percentage passing

Sieve size	Gradation limit	Operating range	Contract compliance
No. 10	100	100	100
No. 16	95–100	92–100	85–100
No. 30	35–85	25–95	20–98
No. 50	10–30	6–35	2–40
No. 100	0–4	0–7	0–10
No. 200	0–1	0–3	0–5

Test the crumb rubber modifier gradation under ASTM C 136 except

1. Split or quarter 100 ± 5 g from the crumb rubber modifier sample and dry to a constant mass at a temperature from 57 to 63 degrees C and record the dry sample mass. Place the crumb rubber modifier sample and 5 g of talc in a 1/2-liter jar. Seal the jar, then shake the jar by hand for at least 1 minute to mix the crumb rubber modifier and the talc. Continue shaking or open the jar and stir until the particle agglomerates and clumps are broken and the talc is uniformly mixed.
2. Place 1 rubber ball on each sieve. Each ball must weigh 8.5 ± 0.5 g, measure 24.5 ± 0.5 mm in diameter, and have a Shore Durometer "A" hardness of 50 ± 5 determined under ASTM D 2240. After sieving the combined material for 10 ± 1 minutes, disassemble the sieves. Brush material adhering to the bottom of a sieve into the next finer sieve. Weigh and record the mass of the material retained on the 2.36-millimeter sieve and leave this material (do not discard) on the scale or balance. Fabric balls must remain on the scale or balance and be placed together on the side to prevent them from being covered or disturbed when the material from finer sieves is placed onto the scale or balance. The material retained on the 2.00-millimeter sieve must be added to the scale or balance. Weigh and record that mass as the accumulative mass retained on the 2.00-millimeter sieve. Continue weighing and recording the accumulated masses retained on the remaining sieves until the accumulated mass retained in the pan has been determined. Before discarding the crumb rubber modifier sample, separately weigh and record the total mass of fabric balls in the sample.
3. Determine the mass of material passing the 75-micrometer sieve by subtracting the accumulated mass retained on the 75-micrometer sieve from the accumulated mass retained in the pan. If the material passing the 75-micrometer sieve has a mass of 5 g or less, cross out the recorded number for the accumulated mass retained in the pan and copy the number recorded for the accumulated mass retained on the 75-micrometer sieve and record that number, next to the crossed out number, as the accumulated mass retained in the pan. If the material passing the 75-micrometer sieve has a mass greater than 5 g, cross out the recorded number for the accumulated mass retained in the pan, subtract 5 g from that number and record the difference next to the crossed out number. The adjustment to the accumulated mass retained in the pan accounts for the 5 g of talc added to the sample. For calculation purposes, the adjusted total sample mass is the same as the adjusted accumulated mass retained in the pan. Determine the percent passing based on the adjusted total sample mass and record to the nearest 0.1 percent.

37-2.05B(2)(e) Asphalt Rubber Binder

Asphalt rubber binder must be a combination of:

1. Asphalt binder

2. Asphalt modifier
3. Crumb rubber modifier

Asphalt rubber binder blending equipment must be authorized under the Department's material plant quality program.

The blending equipment must allow the determination of weight percentages of each asphalt rubber binder ingredient.

Asphalt rubber binder must be 79 ± 1 percent by weight asphalt binder and 21 ± 1 percent by weight of crumb rubber modifier. The minimum percentage of crumb rubber modifier must be 20.0 percent and lower values may not be rounded up.

Crumb rubber modifier must be 76 ± 2 percent by weight scrap tire crumb rubber and 24 ± 2 percent by weight high natural rubber.

Asphalt modifier and asphalt binder must be blended at the production site. Asphalt modifier must be from 2.5 to 6.0 percent by weight of the asphalt binder in the asphalt rubber binder. The asphalt rubber binder supplier determines the exact percentage.

If blended, the asphalt binder must be from 375 to 440 degrees F when asphalt modifier is added and the mixture must circulate for at least 20 minutes. Asphalt binder, asphalt modifier, and crumb rubber modifier may be proportioned and combined simultaneously.

The blend of asphalt binder and asphalt modifier must be combined with crumb rubber modifier at the asphalt rubber binder production site. The asphalt binder and asphalt modifier blend must be from 375 to 440 degrees F when crumb rubber modifier is added. Combined ingredients must be allowed to react at least 45 minutes at temperatures from 375 to 425 degrees F except the temperature must be at least 10 degrees F below the flash point of the asphalt rubber binder.

After reacting, the asphalt rubber binder must have the values for the quality characteristics shown in the following table:

Asphalt Rubber Binder			
Quality characteristic	Test method	Requirement	
		Min	Max
Cone penetration @ 25 °C, 1/10 mm	ASTM D 217	25	60
Resilience @ 25 °C, percent rebound	ASTM D 5329	18	50
Field softening point, °C	ASTM D 36	55	88
Viscosity @190 °C, Pa • s ($\times 10^{-3}$)	ASTM D 7741	1500	2500

Maintain asphalt rubber binder at a temperature from 375 to 415 degrees F.

Stop heating unused asphalt rubber binder 4 hours after the 45-minute reaction period. Reheating asphalt rubber binder that cools below 375 degrees F is a reheat cycle. Do not exceed 2 reheat cycles. If reheating, asphalt rubber binder must be from 375 to 415 degrees F before use.

During reheating, you may add scrap tire crumb rubber. Scrap tire crumb rubber must not exceed 10 percent by weight of the asphalt rubber binder. Allow added scrap tire crumb rubber to react for at least 45 minutes. Reheated asphalt rubber binder must comply with the specifications for asphalt rubber binder.

37-2.05B(2)(f) Screenings

Before precoating with asphalt binder and when tested under California Test 202, screenings for asphalt rubber seal coat must have the gradation shown in the following table:

Asphalt Rubber Seal Coat Screenings Gradation

Sieve sizes	Percentage passing by weight		
	Coarse 1/2" max	Medium 1/2" max	Fine 3/8" max
3/4"	100	100	100
1/2"	75–90	85–90	95–100
3/8"	0–20	0–30	70–85
No. 4	0–2	0–5	0–15
No. 8	--	--	0–5
No. 200	0–1	0–1	0–1

Screenings must have the values for the properties shown in the following table:

Seal Coat Screenings

Properties	Test method	Value
Cleanness value, min	California Test 227	80
Durability, min	California Test 229	52

37-2.05B(3) Construction

37-2.05B(3)(a) General

Reserved

37-2.05B(3)(b) Equipment

Self-propelled distributor truck for applying asphalt rubber binder must have the following features:

1. Heating unit
2. Internal mixing unit
3. Pumps that spray asphalt rubber binder within 0.05 gal/sq yd of the specified rate
4. Fully circulating spray bar that applies asphalt rubber binder uniformly
5. Tachometer
6. Pressure gages
7. Volume measuring devices
8. Thermometer
9. Observation platform on the rear of the truck for an observer on the platform to see the nozzles and unplug them if needed

37-2.05B(3)(c) Precoating Screenings

For asphalt rubber seal coat, do not recombine fine materials collected in dust control systems except cyclone collectors or knock-out boxes with any other aggregate used in the production of screenings.

For asphalt rubber seal coat, screenings must be preheated from 260 to 325 degrees F. Coat with any of the asphalts specified in the table titled "Performance Graded Asphalt Binder" in section 92. Coat at a central mixing plant. The asphalt must be from 0.5 to 1.0 percent by weight of dry screenings. The Engineer determines the exact rate.

Plant must be authorized under the Department's material plant quality program.

Do not stockpile preheated or precoated screenings.

37-2.05B(3)(d) Asphalt Rubber Binder Application

Apply asphalt rubber binder immediately after the reaction period. At the time of application, the temperature of asphalt rubber binder must be from 385 to 415 degrees F.

Apply asphalt rubber binder at a rate from 0.55 to 0.65 gal/sq yd. The Engineer determines the exact rate.

Apply asphalt rubber binder when the atmospheric temperature is from 60 to 105 degrees F and the pavement surface temperature is at least 55 degrees F.

Do not apply asphalt rubber binder unless there are sufficient screenings available to cover the asphalt rubber binder within 2 minutes. Intersections, turn lanes, gore points, and irregular areas must be covered within 15 minutes.

Do not apply asphalt rubber binder when weather or road conditions are unsuitable, including high wind or when the pavement is damp. In windy conditions you may adjust the distributor bar height and distribution speed, and use shielding equipment, if the Engineer authorizes your request.

37-2.05B(3)(e) Screenings Application

During transit, cover precoated screenings for asphalt rubber seal coat with tarpaulins if the ambient air temperature is below 65 degrees F or the haul time exceeds 30 minutes.

At the time of application, screenings for asphalt rubber seal coat must be from 225 to 325 degrees F.

Spread screenings at a rate from 28 to 40 lb/sq yd. The exact rate is determined by the Engineer. Spread to within 10 percent of the determined rate.

37-2.05B(3)(f) Rolling and Sweeping

Perform initial rolling within 90 seconds of spreading screenings. Do not spread screenings more than 200 feet ahead of the initial rolling.

For final rolling, you may request use of a steel-wheeled roller weighing from 8 to 10 tons, static mode only.

Perform a final sweeping before Contract acceptance. The final sweeping must not dislodge screenings.

Dispose of swept screenings at least 150 feet from any waterway.

37-2.05B(4) Payment

Screenings for asphalt rubber seal coat are measured by coated weight after they are preheated and precoated with asphalt binder. The weight of screenings must be the coated weight.

If recorded batch weights are printed automatically, the bid item for screenings for asphalt-rubber seal coat are measured using the printed batch weights, provided:

1. Total aggregate weight for screenings per batch is printed
2. Total asphalt binder weight per batch is printed

3. Each truckload's zero tolerance weight is printed before weighing the first batch and after weighing the last batch
4. Time, date, mix number, load number and truck identification are correlated with a load slip
5. A copy of the recorded batch weights is certified by a licensed weighmaster and submitted to the Engineer

Screenings for asphalt rubber seal coat is paid for as precoated screenings.

Asphalt-rubber binder is measured under the specifications for asphalts.

If test results for gradation tests do not comply with the specifications, deductions are taken.

Each gradation test for scrap tire crumb rubber represents 10,000 lbs or the amount used in that day's production, whichever is less.

Each gradation test for high natural rubber represents 3,400 lbs or the amount used in that day's production, whichever is less.

For each gradation test, the following pay deductions will be taken from the asphalt rubber bid item:

Gradation Test		
Material	Test result ^a	Deduction
Scrap tire crumb rubber	Operating range < TR < Contract compliance	\$250
Scrap tire crumb rubber	TR > Contract compliance	\$1,100
High natural crumb rubber	Operating range < TR < Contract compliance	\$250
High natural crumb rubber	TR > Contract compliance	\$600

^a Test Result = TR

37-2.05C Modified Asphalt Binder Seal Coat

Reserved

03-21-14

37-2.06 STRESS ABSORBING MEMBRANE INTERLAYER

37-2.06A General

Section 37-2.06 applies where a stress absorbing membrane interlayer (SAMI) is shown.

Comply with section 37-2.05B except a flush coat is not required.

37-2.06B Materials

For SAMI, screenings must comply with the 3/8-inch maximum gradation.

37-2.06C Construction

For SAMI, section 37-2.01C(7) does not apply.

Final rolling and sweeping are not required for SAMI.

37-2.06D Payment

Not Used

37-2.07–37-2.10 RESERVED

Add to section 37-3.01D(1):

01-18-13

Micro-surfacing spreader operators must attend the prepaving conference.

AA

39 HOT MIX ASPHALT

10-17-14

Replace the headings and paragraphs in section 39 with:

04-18-14

39-1 GENERAL

39-1.01 GENERAL

39-1.01A Summary

Section 39-1 includes general specifications for producing and placing hot mix asphalt.

HMA includes one or more of the following types:

- 1. Type A HMA
- 2. RHMA-G
- 3. OGFC
- 4. BWC
- 5. Minor HMA

If a warm mix asphalt technology is specified, the warm mix asphalt technology to be used must be authorized. For Department-authorized warm mix asphalt technologies, go to the METS website.

39-1.01B Definitions

binder replacement: Binder from RAP expressed as a percent of the total binder in the mix.

coarse aggregate: Aggregate retained on a no. 4 sieve.

fine aggregate: Aggregate passing the no. 4 sieve.

leveling course: Thin layer of HMA used to correct minor variations in the longitudinal and transverse profile of the pavement before placement of other pavement layers.

lower course: Layer of HMA below 0.2 feet from finished grade exclusive of OGFC.

miscellaneous areas: Areas outside the traveled way such as:

- 1. Median areas not including inside shoulders
- 2. Island areas
- 3. Sidewalks

4. Gutters
5. Ditches
6. Overside drains
7. Aprons at ends of drainage structures

processed RAP: RAP that has been fractionated.

supplemental fine aggregate: Aggregate passing the no. 30 sieve, including hydrated lime, portland cement, and fines from dust collectors.

surface course: Upper 0.2 feet of HMA exclusive of OGFC.

top layer: Final riding surface.

39-1.01C Submittals

39-1.01C(1) General

Reserved

39-1.01C(2) Job Mix Formula

39-1.01C(2)(a) General

Except for the HMA to be used in miscellaneous areas and dikes, submit your proposed JMF for each type of HMA to be used. The JMF must be submitted on the Contractor Job Mix Formula Proposal form along with:

1. Mix design documentation on Contractor Hot Mix Asphalt Design Data form dated within 12 months of submittal
2. JMF verification on a Caltrans Hot Mix Asphalt Verification form, if applicable
3. JMF renewal on a Caltrans Job Mix Formula Renewal form, if applicable
4. MSDS for:
 - 4.1. Asphalt binder
 - 4.2. Supplemental fine aggregate except fines from dust collectors
 - 4.3. Antistrip additives

The Contractor Hot Mix Asphalt Design Data form must show documentation on aggregate quality.

If you cannot submit a Department-verified JMF on a Caltrans Hot Mix Asphalt Verification form dated within 12 months before HMA production, the Engineer verifies the JMF.

Submit a new JMF if you change any of the following:

1. Target asphalt binder percentage greater than ± 0.2 percent
2. Asphalt binder supplier
3. Combined aggregate gradation
4. Aggregate sources
5. Liquid antistrip producer or dosage
6. Average binder content in a new fractionated RAP stockpile by more than ± 2.0 percent from the average RAP binder content reported on page 4 of your Contractor Hot Mix Asphalt Design Data form

7. Average maximum specific gravity in a new fractionated RAP stockpile by more than ± 0.060 from the average maximum specific gravity value reported on page 4 of your Contractor Hot Mix Asphalt Design Data form
8. Any material in the JMF

Allow the Engineer 5 business days from a complete JMF submittal for document review of the aggregate qualities, mix design, and JMF. The Engineer notifies you if the proposed JMF submittal is accepted.

If your JMF fails verification testing, submit an adjusted JMF based on your testing. An adjusted JMF requires a new Contractor Job Mix Formula Proposal form and Contractor Hot Mix Asphalt Design Data form and verification of a plant-produced sample.

You may submit an adjusted aggregate gradation TV on a Contractor Job Mix Formula Proposal form before verification testing. Aggregate gradation TV must be within the TV limits specified.

39-1.01C(2)(b) Job Mix Formula Renewal

You may request a JMF renewal by submitting:

1. Proposed JMF on a Contractor Job Mix Formula Proposal form
2. Previously verified JMF documented on a Caltrans Hot Mix Asphalt Verification form dated within 12 months
3. Mix design documentation on a Contractor Hot Mix Asphalt Design Data form used for the previously verified JMF

39-1.01C(2)(c) Job Mix Formula Modification

For an authorized JMF, submit a modified JMF if you change any of the following:

1. Asphalt binder supplier
2. Liquid antistrip producer
3. Liquid antistrip dosage

You may change any of the above items only once during the Contract.

Submit your modified JMF request a minimum of 15 days before production. Each modified JMF submittal must consist of:

1. Proposed modified JMF on Contractor Job Mix Formula Proposal form, marked *Modified*.
2. Mix design records on Contractor Hot Mix Asphalt Design Data form for the authorized JMF to be modified.
3. JMF verification on Hot Mix Asphalt Verification form for the authorized JMF to be modified.
4. Test results for the modified JMF in compliance with the mix design specifications. Perform tests at the mix design OBC as shown on the Contractor Asphalt Mix Design Data form.

With an accepted modified JMF submittal, the Engineer verifies each modified JMF within 10 days of receiving all verification samples.

39-1.01C(3) Quality Control Plan

With your proposed JMF submittal, submit a QC plan for HMA.

The QC plan must describe the organization and procedures for:

1. Controlling HMA quality characteristics
2. Taking samples, including sampling locations
3. Establishing, implementing, and maintaining QC
4. Determining when corrective actions are needed
5. Implementing corrective actions
6. Methods and materials for backfilling core locations

The QC plan must address the elements affecting HMA quality including:

1. Aggregate
2. Asphalt binder
3. Additives
4. Production
5. Paving

The QC plan must include aggregate QC sampling and testing during lime treatment.

The Engineer reviews the QC plan within 5 business days from the submittal. Do not start HMA production until the Engineer authorizes the plan.

If QC procedures, personnel, tester qualifications, sample testing locations, or lab accreditation status change, submit a QC plan supplement at least 3 business days before implementing the proposed change. Do not implement the change without authorization.

39-1.01C(4) Test Results

For mix design, JMF verification, production start-up, and each 10,000 tons, submit AASHTO T 283 and AASHTO T 324 (Modified) test results to the Engineer and electronically to:

Moisture_Tests@dot.ca.gov

Submit all QC test results, except AASHTO T 283 and AASHTO T 324 (Modified), within 3 business days of a request. Submit AASHTO T 283 QC tests within 15 days of sampling.

For tests performed under AASHTO T 324 (Modified), submit test data and 1 tested sample set within 5 business days of sampling.

If coarse and fine durability index tests are required, submit test results within 2 business days of testing.

If tapered notched wedge is used, submit test result values within 24 hours of testing.

39-1.01C(5) Reserved

39-1.01C(6) Liquid Antistrip Treatment

If liquid antistrip treatment is used, submit the following with your proposed JMF submittal:

1. One 1-pint sample
2. Infrared analysis including copy of absorption spectra
3. Certified copy of test results

4. Certificate of compliance for each liquid antistripping shipment. On each certificate of compliance, include:
 - 4.1. Your signature and printed name
 - 4.2. Shipment number
 - 4.3. Material type
 - 4.4. Material specific gravity
 - 4.5. Refinery
 - 4.6. Consignee
 - 4.7. Destination
 - 4.8. Quantity
 - 4.9. Contact or purchase order number
 - 4.10. Shipment date
6. Proposed proportions for liquid antistripping

For each delivery of liquid antistripping to the HMA production plant, submit a 1-pint sample to METS. Submit shipping documents. Label each liquid antistripping sampling container with:

1. Liquid antistripping type
2. Application rate
3. Sample date
4. Contract number

At the end of each day's production shift, submit production data in electronic and printed media. Present data on electronic media in tab delimited format. Use line feed carriage return with 1 separate record per line for each production data set. Allow sufficient fields for the specified data. Include data titles at least once per report. For each HMA mixing plant type, submit the following information in the order specified:

1. For batch plant mixing:
 - 1.1. Production date
 - 1.2. Time of batch completion
 - 1.3. Mix size and type
 - 1.4. Each ingredient's weight
 - 1.5. Asphalt binder content as a percentage of the total weight of mix
 - 1.6. Liquid antistripping content as a percentage of the asphalt binder weight
2. For continuous mixing plant:
 - 2.1. Production date
 - 2.2. Data capture time
 - 2.3. Mix size and type
 - 2.4. Flow rate of wet aggregate collected directly from the aggregate weigh belt
 - 2.5. Aggregate moisture content as percentage of the dry aggregate weight
 - 2.6. Flow rate of asphalt binder collected from the asphalt binder meter

- 2.7. Flow rate of liquid antistriper collected from the liquid antistriper meter
- 2.8. Asphalt binder content as percentage of the total weight of mix calculated from:
 - 2.8.1. Aggregate weigh belt output
 - 2.8.2. Aggregate moisture input
 - 2.8.3. Asphalt binder meter output
- 2.9. Liquid antistriper content as percentage of the asphalt binder weight calculated from:
 - 2.9.1. Asphalt binder meter output
 - 2.9.2. Liquid antistriper meter output

39-1.01C(7) Lime Treatment

If aggregate lime treatment is used, submit the following with your proposed JMF submittal and each time you produce lime-treated aggregate:

1. Exact lime proportions for fine and coarse virgin aggregate
2. If marination is required, the averaged aggregate quality test results within 24 hours of sampling
3. For dry lime aggregate treatment, a treatment data log from the dry lime and aggregate proportioning device in the following order:
 - 3.1. Treatment date
 - 3.2. Time of day the data is captured
 - 3.3. Aggregate size being treated
 - 3.4. HMA type and mix aggregate size
 - 3.5. Wet aggregate flow rate collected directly from the aggregate weigh belt
 - 3.6. Aggregate moisture content, expressed as a percent of the dry aggregate weight
 - 3.7. Flow rate of dry aggregate calculated from the flow rate of wet aggregate
 - 3.8. Dry lime flow rate
 - 3.9. Lime ratio from the authorized JMF for each aggregate size being treated
 - 3.10. Lime ratio from the authorized JMF for the combined aggregate
 - 3.11. Actual lime ratio calculated from the aggregate weigh belt output, the aggregate moisture input, and the dry lime meter output, expressed as a percent of the dry aggregate weight
 - 3.12. Calculated difference between the authorized lime ratio and the actual lime ratio
4. For lime slurry aggregate treatment, a treatment data log from the slurry proportioning device in the following order:
 - 4.1. Treatment date
 - 4.2. Time of day the data is captured
 - 4.3. Aggregate size being treated
 - 4.4. Wet aggregate flow rate collected directly from the aggregate weigh belt
 - 4.5. Moisture content of the aggregate just before treatment, expressed as a percent of the dry aggregate weight
 - 4.6. Dry aggregate flow rate calculated from the wet aggregate flow rate

- 4.7. Lime slurry flow rate measured by the slurry meter
- 4.8. Dry lime flow rate calculated from the slurry meter output
- 4.9. Authorized lime ratio for each aggregate size being treated
- 4.10. Actual lime ratio calculated from the aggregate weigh belt and the slurry meter output, expressed as a percent of the dry aggregate weight
- 4.11. Calculated difference between the authorized lime ratio and the actual lime ratio
- 4.12. Dry lime and water proportions at the slurry treatment time

Each day during lime treatment, submit the treatment data log on electronic media in tab delimited format on a removable CD-ROM storage disk. Each continuous treatment data set must be a separate record using a line feed carriage return to present the specified data on 1 line. The reported data must include data titles at least once per report.

39-1.01C(8) Warm Mix Asphalt Technology

If a warm mix asphalt technology is used, submit the following with your proposed JMF submittal:

1. MSDS for warm mix asphalt technology 10-17-14

2. For warm mix asphalt water injection foam technology:
 - 2.1. Name of technology
 - 2.2. Proposed foaming water content
 - 2.3. Proposed HMA production temperature range
 - 2.4. Certification from binder supplier stating no antifoaming agent is used. 04-18-14

3. For warm mix asphalt additive technology:
 - 3.1. Name of technology
 - 3.2. Percent admixture by weight of binder and percent admixture by total weight of HMA as recommended by the manufacturer
 - 3.3. Methodology for inclusion of admixture in laboratory-produced HMA
 - 3.4. Proposed HMA production temperature range

Collect and hold data for the duration of the contract and submit the electronic media, daily and upon request. The snapshot of production data must include the following:

1. Date of production
2. Production location
3. Time of day the data is captured
4. HMA mix type being produced and target binder rate
5. HMA additive type, brand, and target rate
6. Temperature of the binder and HMA mixture
7. For a continuous mixing plant, the rate of flow of the dry aggregate calculated from the wet aggregate flow rate as determined by the conveyor scale

8. For a continuous mixing plant, the rate of flow of the asphalt meter
9. For a continuous mixing plant, the rate of flow of HMA additive meter
10. For batch plant mixing, actual batch weights of all ingredients
11. Dry aggregate to binder ratio calculated from metered ingredient output
12. Dry aggregate to HMA additive ratio calculated from metered output

At the end of each day's production shift, submit electronic and printed media from the HMA plant process controller. Present data on electronic media in comma-separated values or tab-separated values format. The captured data for the ingredients represented by production snapshot must have allowances for sufficient fields to satisfy the amount of data required by these specifications and include data titles at least once per report.

39-1.01C(9) Samples

For the samples taken for JMF verification, submit 3 parts to the Engineer and use 1 part for your testing.

At production start-up and within 1000 tons of the halfway point of production of HMA, submit samples split from your HMA production sample for AASHTO T 283 and AASHTO T 324 (Modified) tests to the Engineer.

For production samples taken, submit 3 parts to the Engineer and use 1 part for your testing.

39-1.01C(10)–39-1.01C(11) Reserved

39-1.01C(12) Data Cores

Section 39-1.01C(12) applies if a bid item for data core is shown on the Bid Item List.

Submit a summary of data cores taken and a photograph of each data core to the Engineer and to:

Coring@dot.ca.gov

For each data core, the summary must include:

1. Project identification number
2. Date cored
3. Core identification number
4. Type of materials recovered
5. Type and approximate thickness of unstabilized material not recovered
6. Total core thickness
7. Thickness of each individual material to within:
 - 7.1. For recovered material, 1/2 inch
 - 7.2. For unstabilized material, 1.0 inch
8. Location including:
 - 8.1. County
 - 8.2. Route
 - 8.3. Post mile
 - 8.4. Lane number

- 8.5. Lane direction
- 8.6. Station

Each data core digital photograph must include a ruler laid next to the data core. Each photograph must include:

1. Core
2. Project identification number
3. Core identification number
4. Date cored
5. County
6. Route
7. Post mile
8. Lane number
9. Lane direction

39-1.01C(13) Pavement Smoothness

39-1.01C(13)(a) General

Reserved

39-1.01C(13)(b) Straightedge Measurements

Within 2 business days of performing straightedge measurements, submit areas requiring smoothness correction. Identify locations of smoothness correction by:

1. Location Number
2. District-County-Route
3. Beginning station or post mile to the nearest 0.01 mile
4. For correction areas within a lane:
 - 4.1. Lane direction as NB, SB, EB, or WB
 - 4.2. Lane number from left to right in direction of travel
 - 4.3. Wheel path as "L" for left, "R" for right, or "B" for both
5. For correction areas not within a lane:
 - 5.1. Identify pavement area (i.e., shoulder, weight station, turnout)
 - 5.2. Direction and distance from centerline as "L" for left or "R" for right
6. Estimated size of correction area

39-1.01C(13)(c) Inertial Profiler Certification

At least 5 business days before the start of initial profiling or changing profiler or operator, submit:

1. Inertial profiler certification issued by the Department.
2. Operator certification for the inertial profiler issued by the Department.

3. List of manufacturer's recommended test procedures for the inertial profiler calibration and verification.

Within 2 business days after cross-correlation testing, submit ProVAL profiler certification analysis report for cross-correlation test results performed on test section to the Engineer and to the electronic mailbox address:

smoothness@dot.ca.gov

39-1.01C(13)(d) Inertial Profiler Data

10-17-18

Within 2 business days after each day of inertial profiling, submit profile information to the Engineer and to the electronic mailbox address:

smoothness@dot.ca.gov

The profile information must include:

1. Raw profile data for each lane.
2. ProVAL ride quality analysis report for the International Roughness Index of left and right wheel paths of each lane. Submit this report in pdf file format.
3. ProVAL ride quality analysis report for the Mean Roughness Index of each lane. Submit this report in pdf file format.
4. ProVAL smoothness assurance analysis report for the International Roughness Index of left wheel path. Submit this report in pdf file format.
5. ProVAL smoothness assurance analysis report for the International Roughness Index of right wheel path. Submit this report in pdf file format.
6. ProVAL smoothness assurance analysis report for grinding locations of left wheel path. Submit this report in pdf file format.
7. ProVAL smoothness assurance analysis report for grinding locations of right wheel path. Submit this report in pdf file format.
8. GPS data file for each lane in GPS eXchange. Submit data file in GPS eXchange file format.
9. Manufacturer's recommended inertial profiler calibration and verification test results.
10. Inertial profiler calibration and verification test results including bounce, block, and distance measurement instrument.

04-18-14

Submit the raw profile data in unfiltered electronic pavement profile file (PPF) format. Name the PPF file using the following naming convention:

YYYYMMDD_TTCCRRR_D_L_W_B_E_X_PT.PPF

where:

YYYY = year

MM = Month, leading zero

DD = Day of month, leading zero

TT = District, leading zero

CCC = County, 2 or 3 letter abbreviation as shown in section 1-1.08

RRR = Route number, no leading zeros

D = Traffic direction as NB, SB, WB, or EB

L = Lane number from left to right in direction of travel

W = Wheel path as "L" for left, "R" for right, or "B" for both

B = Beginning station to the nearest foot (i.e., 10+20) or beginning post mile to the nearest hundredth (i.e., 25.06) no leading zero

E = Ending station to the nearest foot (i.e., 14+20) or ending post mile to the nearest hundredth (i.e., 28.06) no leading zero

X = Profile description as "EXIST" for existing pavement, "INTER" for after prepaving smoothness correction, "PAVE" for after paving, and "CORR" for after final surface pavement correction

PT = HMA pavement type

39-1.01C(13)(e) Reserved

39-1.01C(14)–39-1.01C(15) Reserved

39-1.01D Quality Control and Assurance

39-1.01D(1) General

When testing under AASHTO T 324 (Modified), test under AASHTO T 324 with the following parameters:

1. Target air voids must equal 7 ± 1 percent
2. Specimen height must be 60 ± 1 mm
3. Number of test specimens must be 4 (2 test sets)
4. Do not average test sets
5. Test specimen must be a 150 mm gyratory compacted specimen
6. Test temperature must be set at:
 - 6.1. 113 ± 2 degrees F for PG 58
 - 6.2. 122 ± 2 degrees F for PG 64
 - 6.3. 131 ± 2 degrees F for PG 70 and above
7. Measurements for impression must be taken at every 100 passes along the total length of sample
8. Inflection point defined as the number of wheel passes at the intersection of the creep slope and the stripping slope at maximum rut depth
9. Testing shut off must be set at 25,000 passes
10. Submersion time for samples must not exceed 4 hours

10-17-14

04-18-14

Take samples under California Test 125.

HMA samples may be heated a maximum of 2 times for up to 4 hours each.

39-1.01D(2) Job Mix Formula Verification

10-17-14

The Engineer verifies the JMF from samples taken from HMA produced by the plant to be used. The production set point at the plant must be within ± 0.2 from the asphalt binder percentage target value shown in your Contractor Job Mix Formula Proposal form. Notify the Engineer at least 2 business days before sampling materials. Samples may be taken from a different project including a non-Department project if you make arrangements for the Engineer to be present during sampling.

04-18-14

In the Engineer's presence and from the same production run, take samples of:

1. Aggregate. Coarse, fine, and supplemental fine aggregate must be taken from the combined cold feed belt, or hot bins. If lime treatment is required, samples must be taken from individual stockpiles before lime treatment. Samples must be at least 120 lb for each coarse aggregate, 80 lb for each fine aggregate, and 10 lb for each type of supplemental fines. For hot bin samples, the Department combines these aggregate samples to comply with the TV submitted on a Contractor Job Mix Formula Proposal form.
2. Asphalt binder. Take 2 samples minimum. Each sample must be in a 1-quart cylindrical-shaped can with an open top and friction lid. If the asphalt binder is modified or rubberized, the asphalt binder must be sampled with the components blended in the proportions to be used.
3. RAP. RAP samples must be at least 50 lb from each fractionated stockpile used or 100 lb from the belt.
4. Plant-produced HMA. The HMA samples must be at least 250 lb.

For aggregate, RAP, and HMA, split the samples into at least 4 parts and label their containers. Three parts are for the Department's verification testing and 1 part is for your testing.

After acceptance of the JMF submittal, the Engineer verifies each proposed JMF within 20 days of receiving all verification samples.

For JMF verification, the Engineer tests the following for compliance with the specifications:

1. Aggregate quality
2. Aggregate gradation
3. Voids in mineral aggregate on laboratory-produced HMA must comply with the mix design specifications for voids in mineral aggregate
4. HMA quality characteristics for Department acceptance

To verify the HMA for air voids, voids in mineral aggregate, and dust proportion, the Engineer uses an average of 3 briquettes. The Engineer tests plant-produced material.

If the Engineer verifies the JMF, the Engineer furnishes you a Hot Mix Asphalt Verification form.

If the Engineer's test results on plant-produced samples do not show compliance with the specifications, the Engineer notifies you. Adjust your JMF based on your testing unless the Engineer authorizes reverification without adjustments. JMF adjustments may include a change in:

1. Asphalt binder content target value up to ± 0.2 percent from the OBC value submitted on Contractor Hot Mix Asphalt Design Data form
2. Aggregate gradation target values within the target value limits specified in the aggregate gradation table

You may adjust the JMF only once due to a failed verification test.

For each HMA type and aggregate size specified, the Engineer verifies up to 2 proposed JMF submittals including a JMF adjusted after verification failure. If you submit more than 2 JMFs for each type of HMA and aggregate size, the Engineer deducts \$3,000 from payments for each verification exceeding this limit. This deduction does not apply to verifications initiated by the Engineer or if a JMF expires while HMA production is stopped longer than 30 days.

A verified JMF is valid for 12 months.

39-1.01D(3) Job Mix Formula Authorization

You may start HMA production if:

1. The Engineer's review of the JMF shows compliance with the specifications
2. The Department has verified the JMF within 12 months before HMA production
3. The Engineer authorizes the verified JMF

39-1.01D(4) Job Mix Formula Renewal

For a JMF renewal and upon request, in the Engineer's presence and from the same production run, take samples of:

1. Aggregate. Coarse, fine, and supplemental fine aggregate must be taken from combined cold-feed belt, or hot bins. If lime treatment is required, samples must be taken from individual stockpiles before lime treatment. Samples must be at least 120 lb for each coarse aggregate, 80 lb for each fine aggregate, and 10 lb for each type of supplemental fines. For hot bins, the Department combines these aggregate samples to comply with the TV submitted on a Contractor Job Mix Formula Proposal form.
2. Asphalt binder. Take 2 samples minimum. Each sample must be in a 1-quart cylindrical-shaped can with an open top and friction lid. If the asphalt binder is modified or rubberized, the asphalt binder must be sampled with the components blended in the proportions to be used.
3. RAP. RAP samples must be at least 50 lb from each fractionated stockpile.
4. Plant-produced HMA. The HMA samples must be at least 250 lb.

Notify the Engineer at least 2 business days before sampling materials. For aggregate, RAP, and HMA, split samples into at least 4 parts. Submit 3 parts to the Engineer and use 1 part for your testing.

Allow the Engineer 5 business days from a complete JMF reverification submittal for document review of the aggregate qualities, mix design, and JMF.

The most recent aggregate quality test results within the past 12 months may be used for verification of JMF renewal or upon request, the Engineer may perform aggregate quality tests for verification of JMF renewal.

The Engineer verifies the JMF for renewal under section 39-1.01D(2) except:

1. The Engineer keeps the samples until you provide test results for your part on a Contractor Job Mix Formula Renewal form.
2. The Department tests samples of materials obtained from the HMA production unit after you submit test results that comply with the mix design specifications.

3. After completion of the JMF verification renewal document review, the Engineer verifies each proposed JMF within 20 days of receiving the verification renewal samples and the complete Contractor Job Mix Formula Renewal form.
4. You may not adjust the JMF due to a failed verification.
5. For each HMA type and aggregate gradation specified, the Engineer verifies at no cost to you 1 proposed JMF renewal within a 12-month period.

If the Engineer verifies the JMF renewal, the Engineer furnishes you a Hot Mix Asphalt Verification form. The Hot Mix Asphalt Verification form is valid for 12 months.

39-1.01D(5) Job Mix Formula Modification

The Engineer verifies the modified JMF after the modified JMF HMA is placed on the project and verification samples are taken within the first 750 tons. The Engineer tests verification samples for compliance with:

1. Hamburg wheel track mix design specifications
2. Air void content
3. Voids in mineral aggregate on plant-produced HMA mix design specifications
4. Dust proportion mix design specifications

The Engineer may test for moisture susceptibility for compliance with the mix design specifications.

If the modified JMF is verified, the Engineer revises your Hot Mix Asphalt Verification form to include the new asphalt binder source, new liquid antistriper producer, or new liquid antistriper dosage. Your revised form will have the same expiration date as the original form.

If a modified JMF is not verified, stop production and any HMA placed using the modified JMF is rejected.

The Engineer deducts \$2,000 from payments for each JMF modification.

39-1.01D(6) Certifications

39-1.01D(6)(a) General

Laboratories testing aggregate and HMA qualities used to prepare the mix design and JMF must be qualified under AASHTO Materials Reference Laboratory program and the Department's Independent Assurance Program.

39-1.01D(6)(b) Hot Mix Asphalt Plants

Before production, the HMA plant must have a current qualification under the Department's Material Plant Quality Program.

39-1.01D(6)(c) Inertial Profiler Certifications

The inertial profiler equipment must display a current certification decal with expiration date.

The inertial profiler operator and device certifications must be not more than 12 months old.

The operator must be certified for each different model of inertial profiler device operated.

39-1.01D(6)(d)–39-1.01D(6)(e) Reserved

39-1.01D(7) Preparing Meeting

Meet with the Engineer at a preparing meeting at a mutually agreed time and place. Discuss the QC plan and the methods of performing HMA production and paving work.

The following personnel must attend the prepaving meeting:

1. Project manager
2. Superintendent
3. HMA plant manager
4. HMA paving foreman

If a warm mix asphalt technology is used, a technical representative for warm mix asphalt technology must attend the prepaving meeting.

39-1.01D(8) Quality Control

39-1.01D(8)(a) General

QC test results must comply with the specifications for Department acceptance.

Prepare 3 briquettes for air voids content and voids in mineral aggregate determination. Report the average of 3 tests.

Except for smoothness, if 2 consecutive QC test results or any 3 QC test results for 1 day's production do not comply with the materials specifications:

1. Stop HMA production
2. Notify the Engineer
3. Take corrective action
4. Demonstrate compliance with the specifications before resuming production and placement

For QC tests performed under AASHTO T 27, results are considered 1 QC test regardless of number of sieves out of compliance.

Do not resume production and placement until the Engineer authorizes your corrective action proposal.

39-1.01D(8)(b) Reserved

39-1.01D(8)(c) Aggregate

39-1.01D(8)(c)(i) General

Reserved

39-1.01D(8)(c)(ii) Aggregate Lime Treatments

If lime treatment is required, sample coarse and fine aggregate from individual stockpiles before lime treatment. Combine aggregate in the JMF proportions. Test the aggregate under the test methods and frequencies shown in the following table:

Aggregate Quality Control During Lime Treatment

Quality characteristic	Test method	Minimum sampling and testing frequency
Sand equivalent ^{a, b}	AASHTO T 176	1 per 750 tons of untreated aggregate
Percent of crushed particles	AASHTO T 335	1 per 10,000 tons or 2 per project whichever is greater
Los Angeles Rattler	AASHTO T 96	
Fine aggregate angularity	AASHTO T 304 Method A	
Flat and elongated particles	ASTM D4791	

^aReport test results as the average of 3 tests from a single sample.

^bUse of a sand reading indicator is required as shown in AASHTO T 176, Figure 1. Sections 4.7, 4.8, 7.1.2, and 8.4.3 do not apply.

For lime slurry aggregate treatment, determine the aggregate moisture content at least once every 2 hours of treatment. Calculate moisture content under AASHTO T 329 and report it as a percent of dry aggregate weight. Use the moisture content calculations as a set point for the proportioning process controller.

The device controlling lime and aggregate proportioning must produce a treatment data log. The log consists of a series of data sets captured at 10-minute intervals throughout daily treatment. The data must be a treatment activity register and not a summation. The material represented by a data set is the quantity produced 5 minutes before and 5 minutes after the capture time. For the duration of the Contract, collected data must be stored by the controller.

If 3 consecutive sets of recorded treatment data indicate a deviation of more than 0.2 percent above or below the lime ratio in the accepted JMF, stop treatment and take corrective action.

If a set of recorded treatment data indicates a deviation of more than 0.4 percent above or below the lime ratio in the accepted JMF, stop treatment and do not use the material represented by that set of data in HMA.

If 20 percent or more of the total daily treatment indicates a deviation of more than 0.2 percent above or below the lime ratio in the accepted JMF, stop treatment and do not use that day's treated aggregate in HMA.

The Engineer may order you to stop aggregate treatment activities for any of following:

1. You fail to submit treatment data log
2. You fail to submit aggregate QC data for marinated aggregate
3. You submit incomplete, untimely, or incorrectly formatted data
4. You do not take corrective actions
5. You take late or unsuccessful corrective actions
6. You do not stop treatment when proportioning tolerances are exceeded
7. You use malfunctioning or failed proportioning devices

If you stop treatment for noncompliance, notify the Engineer of any corrective actions taken and conduct a successful 20-minute test run before resuming treatment.

39-1.01D(8)(d) Liquid Antistrip Treatment

For continuous mixing or batch-plant mixing, sample asphalt binder before adding liquid antistrip. For continuous mixing, sample the combined asphalt binder and liquid antistrip after the static mixer.

39-1.01D(8)(e) Production Start-up Evaluation

You and the Engineer evaluate HMA production and placement at production start-up.

Within the first 750 tons produced on the 1st day of HMA production, in the Engineer's presence, and from the same production run, take samples of:

1. Aggregate
2. Asphalt binder
3. RAP
4. HMA

Sample aggregate from the combined cold-feed belt or hot bin. Take RAP samples from the RAP system.

For aggregate, RAP, and HMA, split the samples into at least 4 parts and label their containers. Submit 3 parts to the Engineer and keep 1 part.

You and the Engineer must test the samples and report test results, except for AASHTO T 324 (Modified) and AASHTO T 283 test results, within 5 business days of sampling. For AASHTO T 324 (Modified) and AASHTO T 283 test results, report test results within 15 days of sampling. If you proceed before receipt of the test results, the Engineer may consider the HMA placed to be represented by these test results.

Take one 4- or 6-inch diameter density core for each 250 tons or portion thereof of HMA placed. For each density core, the Engineer reports the bulk specific gravity determined under AASHTO T 275, Method A, in addition to the percent of theoretical maximum density.

39-1.01D(8)(f) Hot Mix Asphalt Density

During HMA placement determine HMA density using a nuclear gauge. On the 1st day of production, develop a correlation factor between cores and nuclear gauge under California Test 375.

Test for in-place density using cores and a nuclear gauge. Test at random locations you select and include the test results in your QC production tests reports.

39-1.01D(8)(g) Tapered Notched Wedge

Perform QC testing on the completed tapered notched wedge joint as follows:

1. Perform field compaction tests at the rate of 1 test for each 750-foot section along the joint. Select random locations for testing within each 750-foot section.
2. Perform field compaction tests at the centerline of the joint, 6 inches from the upper vertical notch, after the adjacent lane is placed and before opening the pavement to traffic.
3. Determine theoretical maximum density.
4. Determine percent compaction of the longitudinal joint as the ratio of the daily average of the field compaction values and the maximum density test results.

Determine percent compaction values each day the tapered notched wedge joint is completed. If the percent compaction of 1 day's production is less than 91 percent, that day's notched wedge joint is

rejected. Discontinue placement of the tapered notched wedge and notify the Engineer of changes you will make to your construction process in order to comply with the specifications.

39-1.01D(8)(h) Density Cores

To determine density, take 4- or 6-inch diameter density cores at least once every 5 business days. Take 1 density core for every 250 tons of HMA from random locations the Engineer designates. Take density cores in the Engineer's presence and backfill and compact holes with authorized material. Before submitting a density core, mark it with the density core's location and place it in a protective container.

If a density core is damaged, replace it with a density core taken within 1 foot longitudinally from the original density core. Relocate any density core located within 1 foot of a rumble strip to 1 foot transversely away from the rumble strip.

For a tapered notched wedge joint, take 4- or 6-inch diameter density cores 6 inches from the upper vertical notch of the completed longitudinal joint for every 3,000 feet at locations designated by the Engineer. Take cores after the adjacent lane is placed and before opening the pavement to traffic. Cores must be taken in the presence of the Engineer and backfill and compact holes with authorized material. Before submitting a density core, mark it with the core's location and place it in a protective container.

39-1.01D(8)(i) Reserved

39-1.01D(8)(j) Pavement Smoothness

39-1.01D(8)(j)(i) General

Test pavement smoothness using an inertial profiler except use a 12-foot straightedge for the HMA pavement at the following locations:

1. Traffic lanes less than 1,000 feet in length including ramps, turn lanes, and acceleration and deceleration lanes
2. HMA pavement within 3 feet from and parallel to the construction joint formed between curbs, gutters, or existing pavement
3. Areas within 15 feet of manholes
4. Shoulders
5. Weigh-in-motion areas
6. Miscellaneous areas such as medians, gore areas, turnouts, and maintenance pullouts

Where inertial profiler testing is required, pavement smoothness for each lane must be determined by the International Roughness Index for the left and right wheel paths in an individual lane and then averaging the results. The average of the International Roughness Index values from the left and right wheel paths for the same lane is the Mean Roughness Index of the lane. The wheel paths are a pair of lines 3 feet from and parallel to the edge of a lane. Left and right wheel paths are based on the direction of travel.

Where inertial profiler testing is required, identify areas of localized roughness. Areas of localized roughness must be identified using the FHWA's engineering software ProVAL smoothness assurance analysis by calculating continuous International Roughness Index values for each wheel path with a 25-foot interval using a 250 mm filter.

Collect profiling data under AASHTO R 56 and analyze data using 250 mm and International Roughness Index filters.

39-1.01D(8)(j)(ii) Inertial Profiler Calibration and Verification Tests

Operate the inertial profiler according to the manufacturer's instructions and AASHTO R 57 at 1-inch recording intervals.

Notify the Engineer 2 business days before performing inertial profiler calibration and verification testing.

Conduct the following inertial profiler calibration and verification tests in the Engineer's presence each day before performing inertial profiling:

1. Block test. Verify the height sensor accuracy under California Test 387.
2. Bounce test. Verify the combined height sensor and accelerometer accuracy under California Test 387.
3. Distance measurement instrument test. Calibrate the accuracy of the testing procedure under California Test 387.
4. Manufacturer's recommended tests.

Conduct cross-correlation inertial profiler verification test in the Engineer's presence before performing initial profiling. Verify cross-correlation inertial profiler verification test at least annually. Conduct 5 repeat runs of the inertial profiler on an authorized test section. The test section must be on an existing asphalt concrete pavement surface 0.1 mile long. Calculate a cross-correlation to determine the repeatability of your device under California Test 387 using ProVAL profiler certification analysis with a 3 feet maximum offset. The cross-correlation must be a minimum of 0.92.

For each 0.1 mile section, your International Roughness Index values must be within 10 percent of the Department's International Roughness Index values. The Engineer may order you to recalibrate your inertial profiler equipment and reprofile. If your results are inaccurate due to operator error, the Engineer may disqualify your inertial profiler operator.

39-1.01D(8)(j)(iii) Smoothness Testing

Notify the Engineer of start location by station and start time at least 2 business days before profiling.

Remove foreign objects on the pavement surface before profiling.

Mark the beginning and ending station on the pavement shoulder before profiling. Stationing must be the same when profiling more than one surface.

While collecting the profile data to determine the International Roughness Index values, record the following locations in the raw profile data:

1. Begin and end of all bridge approach slabs
2. Begin and end of all bridges
3. Begin and end of all culverts visible on the roadway surface
4. Begin and end of all at-grade intersections

10-17-14

04-18-14

Determine the Mean Roughness Index for 0.1-mile fixed sections using the ProVAL ride quality analysis with a 250 mm filter. Profile the left and right wheel paths of each lane. Calculate the Mean Roughness Index of each lane. A partial section less than 0.1 mile that is the result of an interruption to continuous pavement surface must comply with the Mean Roughness Index specifications for a full section. Adjust the Mean Roughness Index for a partial section to reflect a full section based on the proportion of a section paved.

Determine the areas of localized roughness using a continuous International Roughness Index for each wheel path with a 25-foot interval using a 250 mm filter.

Pavement smoothness must comply with the specifications in section 39-1.01D(9)(c).

39-1.01D(9) Department Acceptance

39-1.01D(9)(a) General

The Department tests treated aggregate for acceptance before lime treatment except for gradation.

The Engineer takes HMA samples for AASHTO T 283 and AASHTO T 324 (Modified) from one of the following:

10-17-14

1. At the plant
2. At the truck
3. Windrow

The Engineer takes HMA samples for all other tests from one of the following:

1. At the plant
2. At the truck
3. Windrow
4. Mat behind the paver

04-18-14

The Engineer's sampling and testing is independent of your QC sampling and testing.

If you request, the Engineer splits samples and provides you with a part.

No single test result may represent more than 750 tons or one day's production, whichever is less, excluding AASHTO T 283 and AASHTO T 324 (Modified).

Except for smoothness, if 2 consecutive Department acceptance test results or any 3 Department acceptance test results for 1 day's production do not comply with the specifications:

1. Stop HMA production
2. Take corrective action
3. Demonstrate compliance with the specifications before resuming production and placement

10-17-14

For Department acceptance tests performed under AASHTO T 27, results are considered 1 Department acceptance test regardless of the number of sieves out of compliance.

04-18-14

The Engineer accepts HMA based on:

1. Authorized JMF
2. Authorized QC plan
3. Asphalt binder compliance
4. Asphalt emulsion compliance
5. Visual inspection
6. Pavement smoothness

39-1.01D(9)(b) In-Place Density

10-17-14

Except for HMA pavement placed using method compaction, the Engineer tests the density core you take from each 250 tons of HMA. The Engineer determines the percent of theoretical maximum density for each density core by determining the density core's density and dividing by the theoretical maximum density.

04-18-14

Density cores must be taken from the final layer, cored to the specified total paved thickness.

If the percent of theoretical maximum density does not comply with the specifications, the Engineer may accept the HMA and take a payment deduction.

For acceptance of a completed tapered notched wedge joint, the Engineer determines density from cores based on:

1. Field compaction by measuring the bulk specific gravity of the cores under AASHTO T 275, Method A
2. Percent compaction as the ratio of the average of the bulk specific gravity of the core for each day's production to the maximum density test value

39-1.01D(9)(c) Pavement Smoothness

For areas that require pavement smoothness determined using an inertial profiler, the pavement surface must:

1. Have no areas of localized roughness with an International Roughness Index greater than 160 in/mi
2. Comply with the Mean Roughness Index requirements shown in the following table for a 0.1 mile section:

HMA^a Pavement Smoothness Acceptance Criteria

HMA thickness	Mean Roughness Index requirement
> 0.20 foot	60 in/mi or less
≤ 0.20 foot	75 in/mi or less

^a Except OGFC

The final surface of HMA must comply with the Mean Roughness Index requirements before placing OGFC. Correct pavement to the Mean Roughness Index specifications. Localized roughness greater than 160 in/mi must be corrected regardless of the International Roughness Index values of a 0.1-mile section.

For areas that require pavement smoothness determined using a 12-foot straightedge, the HMA pavement surface must not vary from the lower edge of the straightedge by more than:

1. 0.01 foot when the straightedge is laid parallel with the centerline
2. 0.02 foot when the straightedge is laid perpendicular to the centerline and extends from edge to edge of a traffic lane
3. 0.02 foot when the straightedge is laid within 24 feet of a pavement conform

Pavement smoothness may be accepted based on your testing in the absence of the Department's testing.

39-1.01D(9)(d) Dispute Resolution

You and the Engineer must work together to avoid potential conflicts and to resolve disputes regarding test result discrepancies. Notify the Engineer within 5 business days of receiving a test result if you dispute the test result.

If you or the Engineer dispute each other's test results, submit QC test results and copies of paperwork including worksheets used to determine the disputed test results. An independent third party performs referee testing. Before the third party participates in a dispute resolution, it must be qualified under AASHTO Materials Reference Laboratory program, and the Department's Independent Assurance Program. The independent third party must have no prior direct involvement on this Contract. By mutual agreement, the independent third party is chosen from:

1. Department laboratory in a district or region not in the district or region the project is located
2. Transportation Laboratory
3. Laboratory not currently employed by you or your HMA producer

If split QC or acceptance samples are not available, the independent third party uses any available material representing the disputed HMA for evaluation.

If the independent third party determines the Department's test results are valid, the Engineer deducts the independent third party's testing costs from payments. If the independent third party determines your test results are valid, the Department pays the independent third party's testing costs.

39-1.02 MATERIALS

39-1.02A General

Reserved

39-1.02B Mix Design

39-1.02B(1) General

The HMA mix design must comply with AASHTO R 35 except:

1. Notes 3, 6, and 10 do not apply
2. AASHTO M 323 does not apply on combinations of aggregate gradation and asphalt binder contents to determine the OBC and HMA mixture qualities

The Contractor Hot Mix Asphalt Design Data form must show documentation on aggregate quality.

39-1.02B(2) Hot Mix Asphalt Treatments

If the test results for AASHTO T 283 or AASHTO T 324 (Modified) for untreated plant-produced HMA are less than the minimum requirements for HMA mix design, determine the plasticity index of the aggregate blend under California Test 204.

If the plasticity index is greater than 10, do not use that aggregate blend.

If the plasticity index is from 4 to 10, treat the aggregate with dry lime with marination or lime slurry with marination.

If the plasticity index is less than 4, treat the aggregate with dry lime or lime slurry with marination, or treat the HMA with liquid antistripping.

39-1.02B(3) Warm Mix Asphalt Technology

For HMA with warm mix asphalt additive technology, produce HMA mix samples for your mix design using your methodology for inclusion of warm mix asphalt admixture in laboratory-produced HMA. For

warm mix asphalt water injection foam technology, the use of foamed asphalt for mix design is not required.

39-1.02C Asphalt Binder

Asphalt binder must comply with section 92.

For replace asphalt concrete surfacing or hot mix asphalt (leveling) the grade of asphalt binder for the HMA must be PG 64-10 or PG 64-16.

39-1.02D Aggregate

39-1.02D(1) General

Aggregate must be clean and free from deleterious substances.

The aggregate for replace asphalt concrete surfacing and hot mix asphalt (leveling) must comply with the gradation specifications for Type A HMA in section 39-2.02.

39-1.02D(2) Aggregate Gradations

10-17-14

Aggregate gradation must be determined before the addition of asphalt binder and must include supplemental fines. Test for aggregate gradation under AASHTO T 27. Do not wash the coarse aggregate. Use a mechanical sieve shaker. Aggregate shaking time must not exceed 10 minutes for each coarse and fine aggregate portion.

04-18-14

Choose a target value within the target value limits shown in the tables titled "Aggregate Gradations."

Gradations are based on nominal maximum aggregate size.

39-1.02D(3) Aggregate Lime Treatments

39-1.02D(3)(a) General

If aggregate lime treatment is required, virgin aggregate must comply with the aggregate quality specifications.

Lime for treating aggregate must comply with section 24-2.02B.

Water for lime treatment of aggregate with lime slurry must comply with section 24-2.02C.

Notify the Engineer at least 24 hours before the start of aggregate treatment.

Do not treat RAP.

The lime ratio is the pounds of dry lime per 100 lb of dry virgin aggregate expressed as a percentage. Water content of slurry or untreated aggregate must not affect the lime ratio.

Coarse and fine aggregate fractions must have the lime ratio ranges shown in the following table:

Aggregate fractions	Lime ratio percent
Coarse	0.4–1.0
Fine	1.5–2.0
Combined	0.8–1.5

The lime ratio for fine and coarse aggregate must be within ± 0.2 percent of the lime ratio in the accepted JMF. The lime ratio must be within ± 0.2 percent of the authorized lime ratio when you combine the

individual aggregate sizes in the JMF proportions. The lime ratio must be determined before the addition of RAP.

If marination is required, marinate treated aggregate in stockpiles from 24 hours to 60 days before using in HMA. Do not use aggregate marinated longer than 60 days.

Treated aggregate must not have lime balls or clods.

39-1.02D(3)(b) Dry Lime

If marination is required:

1. Treat and marinate coarse and fine aggregates separately
2. Treat the aggregate and stockpile for marination only once
3. Treat the aggregate separate from HMA production

Proportion dry lime by weight with an automatic continuous proportioning system.

If you use a batch-type proportioning system for HMA production, control proportioning in compliance with the specifications for continuous mixing plants. Use a separate dry lime aggregate treatment system for HMA batch mixing including:

1. Pugmill mixer
2. Controller
3. Weigh belt for the lime
4. Weigh belt for the aggregate

If using a continuous mixing plant for HMA production without lime marinated aggregates, use a controller that measures the blended aggregate weight after any additional water is added to the mixture. The controller must determine the quantity of lime added to the aggregate from the aggregate weigh belt input in connection with the manually input total aggregate moisture, the manually input target lime content, and the lime proportioning system output. Use a continuous aggregate weigh belt and pugmill mixer for lime treatment in addition to the weigh belt for the aggregate proportioning to asphalt binder in the HMA plant. If you use a water meter for moisture control for lime treatment, the meter must comply with Department's Material Plant Quality Program manual.

At the time of mixing dry lime with aggregate, the aggregate moisture content must ensure complete lime coating. The aggregate moisture content must not cause aggregate to be lost between the point of weighing the combined aggregate continuous stream and the dryer. Add water to the aggregate for mixing and coating before dry lime addition. Immediately before mixing lime with aggregate, water must not visibly separate from the aggregate.

Mix aggregate, water, and dry lime with a continuous pugmill mixer with twin shafts. Immediately before mixing lime with aggregate, water must not visibly separate from the aggregate. Store dry lime in a uniform and free-flowing condition. Introduce dry lime to the pugmill in a continuous process. The introduction must occur after the aggregate cold feed and before the point of proportioning across a weigh belt and the aggregate dryer. Prevent loss of dry lime.

The pugmill must be equipped with paddles arranged to provide sufficient mixing action and mixture movement. The pugmill must produce a homogeneous mixture of uniformly coated aggregates at mixer discharge.

If the aggregate treatment process is stopped longer than 1 hour, clean the equipment of partially treated aggregate and lime.

Aggregate must be completely treated before introduction into the mixing drum.

39-1.02D(3)(c) Lime Slurry

For lime slurry aggregate treatment, treat aggregate separate from HMA production. Stockpile and marinate the aggregate.

Proportion lime and water with a continuous or batch mixing system.

Add lime to the aggregate as slurry consisting of mixed dry lime and water at a ratio of 1 part lime to from 2 to 3 parts water by weight. The slurry must completely coat the aggregate.

Immediately before mixing lime slurry with the aggregate, water must not visibly separate from the aggregate.

Proportion lime slurry and aggregate by weight in a continuous process.

39-1.02E Liquid Antistrip Treatment

Liquid antistrip must be from 0.25 to 1.0 percent by weight of asphalt binder. Do not use liquid antistrip as a substitute for asphalt binder.

Liquid antistrip total amine value must be 325 minimum when tested under ASTM D2074.

Use only 1 liquid antistrip type or brand at a time. Do not mix liquid antistrip types or brands.

Store and mix liquid antistrip under the manufacturer's instructions.

39-1.02F–39-1.02G Reserved

39-1.02H Hot Mix Asphalt Production

39-1.02H(1) General

Do not start HMA production before verification and authorization of JMF.

HMA plants must be Department-qualified. Before production, the HMA plant must have a current qualification under the Department's Materials Plant Quality Program.

For lime treated aggregate, the HMA plant must be equipped with a bag-house dust system. Material collected in the dust system must be returned to the mix.

Weighing and metering devices used for the production of HMA modified with additives must comply with the requirements of the Department's Material Plant Quality Program. If a loss-in-weight meter is used for dry HMA additive, the meter must have an automatic and integral material delivery control system for the refill cycle.

Calibrate the loss-in-weight meter by:

1. Including at least 1 complete system refill cycle during each calibration test run
2. Operating the device in a normal run mode for 10 minutes immediately before starting the calibration process
3. Isolating the scale system within the loss-in-weight feeder from surrounding vibration
4. Checking the scale system within the loss-in-weight feeder for accuracy before and after the calibration process and daily during mix production
5. Using a 15-minute or 250-pound-minimum test run size for a dry ingredient delivery rate of less than 1 ton per hour.
6. Complying with the limits of Table B, "Conveyor Scale Testing Extremes," in the Department's Material Plant Quality Program

10-17-14

Proportion aggregate by hot or cold-feed control.

Aggregate temperature must not be more than 375 degrees F when mixed with the asphalt binder.

04-18-14

Asphalt binder temperature must be from 275 to 375 degrees F when mixed with aggregate.

Mix HMA ingredients into a homogeneous mixture of coated aggregates.

HMA with or without RAP must not be more than 325 degrees F.

For HMA produced using warm mix asphalt technology, HMA must be at a temperature between 240 and 325 degrees F.

If method compaction is used, HMA must be produced at a temperature between 305 and 325 degrees F.

If you stop production for longer than 30 days, a production start-up evaluation is required.

39-1.02H(2) Liquid Antistrip

If 3 consecutive sets of recorded production data show actual delivered liquid antistrip weight is more than ± 1 percent of the authorized mix design liquid antistrip weight, stop production and take corrective action.

If a set of recorded production data shows actual delivered liquid antistrip weight is more than ± 2 percent of the authorized mix design liquid antistrip weight, stop production. If the liquid antistrip weight exceeds 1.2 percent of the asphalt binder weight, do not use the HMA represented by that data.

The continuous mixing plant controller proportioning the HMA must produce a production data log. The log consists of a series of data sets captured at 10-minute intervals throughout daily production. The data must be a production activity register and not a summation. The material represented by the data is the quantity produced 5 minutes before and 5 minutes after the capture time. For the duration of the Contract, collected data must be stored by the plant controller or a computer's memory at the plant.

The Engineer orders proportioning activities stopped for any of the following:

1. You do not submit data
2. You submit incomplete, untimely, or incorrectly formatted data
3. You do not take corrective actions
4. You take late or unsuccessful corrective actions
5. You do not stop production when proportioning tolerances are exceeded
6. You use malfunctioning or failed proportioning devices

If you stop production, notify the Engineer of any corrective actions taken before resuming.

39-1.02H(3) Warm Mix Asphalt Technology

Proportion all ingredients by weight. The HMA plant process controller must be the sole source of ingredient proportioning control and be fully interfaced with all scales and meters used in the production process. The addition of the HMA additive must be controlled by the plant process controller.

Liquid ingredient additive, including a normally dry ingredient made liquid, must be proportioned with a mass flow meter at continuous mixing plants. Use a mass flow meter or a container scale to proportion liquid additives at batch mixing plants.

Continuous mixing plants using HMA additives must comply with the following:

1. Dry ingredient additives for continuous production must be proportioned with a conveyor scale or a loss-in-weight meter.

2. HMA plant process controller and ingredient measuring systems must be capable of varying all ingredient feed rates proportionate with the dry aggregate delivery at all production rates and rate changes.
3. Liquid HMA additive must enter the production stream with the binder. Dry HMA additive must enter the production stream at or before the mixing area.
4. If dry HMA additives are used at continuous mixing HMA plants, baghouse dust systems must return all captured material to the mix.
5. HMA additive must be proportioned to within ± 0.3 percent of the target additive rate.

Batch mixing plants using HMA additives must comply with the following:

1. Metered HMA additive must be placed in an intermediate holding vessel before being added to the stream of asphalt binder as it enters the pugmill.
2. If a container scale is used, weigh additive before combining with asphalt binder. Keep the container scale separate from other ingredient proportioning. The container scale capacity must be no more than twice the volume of the maximum additive batch size. The container scale's graduations must be smaller than the proportioning tolerance or 0.001 times the container scale capacity.
3. Dry HMA additive proportioning devices must be separate from metering devices for the aggregates and asphalt binder. Proportion dry HMA additive directly into the pugmill or place in an intermediate holding vessel to be added to the pugmill at the appropriate time in the batch cycle. Dry ingredients for batch production must be proportioned with a hopper scale.
4. Zero tolerance for the HMA additive batch scale is ± 0.5 percent of the target additive weight. The indicated HMA additive batch scale weight may vary from the preselected weight setting by up to ± 1.0 percent of the target additive weight.

39-1.02I Geosynthetic Pavement Interlayer

Geosynthetic pavement interlayer must comply with the specifications for pavement fabric, paving mat, paving grid, paving geocomposite grid, or geocomposite strip membrane as shown.

The asphalt binder for geosynthetic pavement interlayer must be PG 64-10, PG 64-16, or PG 70-10.

39-1.02J Tack Coat

Tack coat must comply with the specifications for asphaltic emulsion or asphalt binder. Choose the type and grade.

39-1.02K Miscellaneous Areas and Dikes

For miscellaneous areas and dikes:

1. Choose either the 3/8-inch or 1/2-inch aggregate gradation for Type A HMA.
2. Minimum asphalt binder content must be 6.8 percent for 3/8-inch aggregate and 6.0 percent for 1/2-inch aggregate. If you request and the Engineer authorizes, you may reduce the minimum asphalt binder content.
3. Choose asphalt binder Grade PG 64-10, PG 64-16 or PG 70-10.

For HMA used in miscellaneous areas and dikes, sections 39-1.01C, 39-1.01D, 39-1.02B, 39-1.02D(3), and 39-1.02E–J do not apply.

39-1.03 CONSTRUCTION

39-1.03A General

Do not place HMA on wet pavement or frozen surface.

You may deposit HMA in a windrow and load it in the paver if:

1. Paver is equipped with a hopper that automatically feeds the screed
2. Loading equipment can pick up the windrowed material and deposit it in the paver hopper without damaging base material
3. Activities for deposit, pickup, loading, and paving are continuous
4. HMA temperature in the windrow does not fall below 260 degrees F

10-17-14

HMA placed in a windrow on the roadway surface must not extend more than 250 feet in front of the loading equipment or material transfer vehicle.

04-18-14

You may place HMA in 1 or more layers on areas less than 5 feet wide and outside the traveled way, including shoulders. You may use mechanical equipment other than a paver for these areas. The equipment must produce uniform smoothness and texture.

HMA handled, spread, or windrowed must not stain the finished surface of any improvement, including pavement.

Do not use petroleum products such as kerosene or diesel fuel to release HMA from trucks, spreaders, or compactors.

HMA must be free of:

1. Segregation
2. Coarse or fine aggregate pockets
3. Hardened lumps

Where density or data core samples are taken, backfill and compact holes with authorized material.

Complete finish rolling activities before the pavement surface temperature is:

1. Below 150 degrees F for HMA with unmodified binder
2. Below 140 degrees F for HMA with modified binder
3. Below 130 degrees F for HMA with warm mix asphalt technology

39-1.03B Spreading and Compacting Equipment

39-1.03B(1) General

Paving equipment for spreading must be:

1. Self-propelled
2. Mechanical
3. Equipped with a screed or strike-off assembly that can distribute HMA the full width of a traffic lane
4. Equipped with a full-width compacting device

5. Equipped with automatic screed controls and sensing devices that control the thickness, longitudinal grade, and transverse screed slope

Install and maintain grade and slope references.

The screed must be heated and produce a uniform HMA surface texture without tearing, shoving, or gouging.

The paver must not leave marks such as ridges and indentations unless you can eliminate them by rolling.

Rollers must be equipped with a system that prevents HMA from sticking to the wheels. You may use a parting agent that does not damage the HMA or impede the bonding of layers.

In areas inaccessible to spreading and compacting equipment:

1. Spread the HMA by any means to obtain the specified lines, grades, and cross sections
2. Use a pneumatic tamper, plate compactor, or equivalent to achieve thorough compaction

39-1.03B(2) Material Transfer Vehicle

If a material transfer vehicle is specified, the material transfer vehicle must have sufficient capacity to prevent stopping the paver and must be capable of:

1. Either receiving HMA directly from trucks or using a windrow pickup head to load it from a windrow deposited on the roadway surface
2. Remixing the HMA with augers before transferring into the paver's receiving hopper or feed system
3. Transferring HMA directly into the paver's receiving hopper or feed system

39-1.03B(3) Method Compaction Equipment

For method compaction, each paver spreading HMA must be followed by 3 rollers:

1. One vibratory roller specifically designed to compact HMA. The roller must be capable of at least 2,500 vibrations per minute and must be equipped with amplitude and frequency controls. The roller's gross static weight must be at least 7.5 tons.
2. One oscillating type pneumatic-tired roller at least 4 feet wide. Pneumatic tires must be of equal size, diameter, type, and ply. The tires must be inflated to 60 psi minimum and maintained so that the air pressure does not vary more than 5 psi.
3. One steel-tired, 2-axle tandem roller. The roller's gross static weight must be at least 7.5 tons.

Each roller must have a separate operator. Rollers must be self-propelled and reversible.

39-1.03B(4)–39-1.03B(6) Reserved

39-1.03C Surface Preparation

39-1.03C(1) General

Before placing HMA, remove loose paving particles, dirt, and other extraneous material by any means including flushing and sweeping.

39-1.03C(2) Subgrade

Prepare subgrade to receive HMA under the sections for the material involved. Subgrade must be free of loose and extraneous material.

39-1.03C(3) Reserved

39-1.03C(4) Prepaving Inertial Profiler

Section 39-1.03C(4) applies to existing asphalt concrete surfaces receiving an HMA overlay if a bid item for prepaving inertial profiler is shown in the Bid Item List.

Before starting paving activities, perform prepaving inertial profiler measurements. Prepaving inertial profiler includes taking profiles of the existing pavement, analyzing the data with ProVAL to determine existing pavement International Roughness Index, Mean Roughness Index, and areas of localized roughness.

If the Contract includes cold planing, perform prepaving inertial profiler measurements before cold planning.

If the Contract includes replace asphalt concrete surfacing, perform prepaving inertial profiler measurements after replacing the asphalt concrete surfacing.

39-1.03C(5) Prepaving Grinding

Section 39-1.03C(5) applies to all existing asphalt concrete surfaces that will not be cold planned or milled and that will receive an HMA overlay less than or equal to 0.20 foot exclusive of OGFC if a bid item for prepaving grinding day is shown in the Bid Item List.

After performing prepaving inertial profiling, correct areas of localized roughness greater than 180 in/mi.

Prepaving grinding day includes correcting areas of localized roughness, taking profiles of the corrected areas, and submitting profile data as specified in section 39-1.01C(13)(d).

10-17-14

Notify the Engineer of those areas of localized roughness that cannot be corrected by prepaving grinding according to the ProVAL smoothness assurance analysis grinding report. The Engineer responds to your notification within 5 business days.

04-18-14

For those areas of localized roughness that cannot be corrected by grinding, the Engineer may order you to either (1) not correct the areas of localized roughness or (2) correct areas of localized roughness by a different method and take profiles of the corrected areas with an inertial profiler. Corrective work performed by a different method, including taking profiles of the corrected areas and associated traffic control, is change order work.

If ordered not to correct areas of localized roughness, the smoothness specifications do not apply to the final pavement surface placed in those areas.

Correct prepaving areas of localized roughness that you predict will cause the final surface of HMA pavement to be noncompliant with the smoothness specifications. After correcting prepaving areas of localized roughness, take profiles of the corrected area and submit profile data as specified in section 39-1.01C(13)(d).

Dispose of grinding residue.

Pave within 7 days of correcting areas.

The final pavement surface must comply with section 39-1.01D(9)(c).

If the Engineer determines more time is required for prepaving grinding than the Contract allows for and if prepaving grinding is a controlling activity, the Engineer makes a time adjustment.

39-1.03C(6) Tack Coat

Apply tack coat:

1. To existing pavement including planed surfaces
2. Between HMA layers
3. To vertical surfaces of:
 - 3.1. Curbs
 - 3.2. Gutters
 - 3.3. Construction joints

Before placing HMA, apply tack coat in 1 application at the minimum residual rate shown in the following table for the condition of the underlying surface:

Tack Coat Application Rates for HMA

HMA over:	Minimum Residual Rates (gal/sq yd)		
	CSS1/CSS1h, SS1/SS1h and QS1h/CQS1h Asphaltic Emulsion	CRS1/CRS2, RS1/RS2 and QS1/CQS1 Asphaltic Emulsion	Asphalt Binder and PMRS2/PMCRS2 and PMRS2h/PMCRS2h Asphaltic Emulsion
New HMA (between layers)	0.02	0.03	0.02
PCC and existing AC surfacing	0.03	0.04	0.03
Planed pavement	0.05	0.06	0.04

Notify the Engineer if you dilute asphaltic emulsion with water. The weight ratio of added water to asphaltic emulsion must not exceed 1 to 1.

Measure added water either by weight or volume under section 9-1.02 or you may use water meters from water districts, cities, or counties. If you measure water by volume, apply a conversion factor to determine the correct weight.

With each dilution, submit:

1. Weight ratio of water to bituminous material in the original asphaltic emulsion
2. Weight of asphaltic emulsion before diluting
3. Weight of added water
4. Final dilution weight ratio of water to asphaltic emulsion

Apply to vertical surfaces with a residual tack coat rate that will thoroughly coat the vertical face without running off.

If you request and the Engineer authorizes, you may:

1. Change tack coat rates
2. Omit tack coat between layers of new HMA during the same work shift if:

- 2.1. No dust, dirt, or extraneous material is present
- 2.2. Surface is at least 140 degrees F

Immediately in advance of placing HMA, apply additional tack coat to damaged areas or where loose or extraneous material is removed.

Close areas receiving tack coat to traffic. Do not track tack coat onto pavement surfaces beyond the job site.

Asphalt binder tack coat temperature must be from 285 to 350 degrees F when applied.

39-1.03C(7) Geosynthetic Pavement Interlayer

If specified, place geosynthetic pavement interlayer over a coat of asphalt binder. Place geosynthetic pavement interlayer in compliance with the manufacturer's instructions.

Before placing the geosynthetic pavement interlayer and asphalt binder:

1. Repair cracks 1/4 inch and wider, spalls, and holes in the pavement. Repairing cracks is change order work.
2. Clean the pavement of loose and extraneous material.

Immediately before placing the interlayer, apply 0.25 ± 0.03 gallon of asphalt binder per square yard of interlayer or until the fabric is saturated. Apply asphalt binder the width of the geosynthetic pavement interlayer plus 3 inches on each side. At an interlayer overlap, apply asphalt binder on the lower interlayer the same overlap distance as the upper interlayer.

Align and place the interlayer with no overlapping wrinkles, except a wrinkle that overlaps may remain if it is less than 1/2 inch thick. If the overlapping wrinkle is more than 1/2 inch thick, cut the wrinkle out and overlap the interlayer no more than 2 inches.

The minimum HMA thickness over the interlayer must be 0.12 foot thick including conform tapers. Do not place the interlayer on a wet or frozen surface.

Overlap the interlayer borders between 2 to 4 inches. In the direction of paving, overlap the following roll with the preceding roll at any break.

You may use rolling equipment to correct distortions or wrinkles in the interlayer.

If asphalt binder tracked onto the interlayer or brought to the surface by construction equipment causes interlayer displacement, cover it with a small quantity of HMA.

Before placing HMA on the interlayer, do not expose the interlayer to:

1. Traffic except for crossings under traffic control and only after you place a small HMA quantity
2. Sharp turns from construction equipment
3. Damaging elements

Pave HMA on the interlayer during the same work shift.

39-1.03D Longitudinal Joints

39-1.03D(1) General

Longitudinal joints in the top layer must match lane lines. Alternate the longitudinal joint offsets in the lower layers at least 0.5 foot from each side of the lane line. You may request other longitudinal joint placement patterns.

A vertical longitudinal joint of more than 0.15 foot is not allowed at any time between adjacent lanes open to traffic.

For HMA thickness of 0.15 foot or less, the distance between the ends of the adjacent surfaced lanes at the end of each day's work must not be greater than can be completed in the following day of normal paving.

For HMA thickness greater than 0.15 foot, you must place HMA on adjacent traveled way lanes or shoulder so that at the end of each work shift the distance between the ends of HMA layers on adjacent lanes is from 5 to 10 feet. Place additional HMA along the transverse edge at each lane's end and along the exposed longitudinal edges between adjacent lanes. Hand rake and compact the additional HMA to form temporary conforms. You may place kraft paper or other authorized release agent under the conform tapers to facilitate the taper removal when paving activities resume.

If placing HMA against the edge of existing pavement, sawcut or grind the pavement straight and vertical along the joint and remove extraneous material.

39-1.03D(2) Tapered Notched Wedge

For divided highways with an HMA lift thickness greater than 0.15 foot, you may construct a 1-foot wide tapered notched wedge joint as a longitudinal joint between adjacent lanes open to traffic. A vertical notch of 0.75 inch maximum must be placed at the top and bottom of the tapered wedge.

The tapered notched wedge must retain its shape while exposed to traffic. Pave the adjacent lane within 1 day.

Construct the tapered portion of the tapered notched wedge with an authorized strike-off device. The strike-off device must provide a uniform slope and must not restrict the main screed of the paver.

You may use a device attached to the screed to construct longitudinal joints that will form a tapered notched wedge in a single pass. The tapered notched wedge must be compacted to a minimum of 91 percent compaction.

39-1.03E Edge Treatments

Construct edge treatment on the HMA pavement as shown.

Where a safety edge is required, use the same type of HMA used for the adjacent lane or shoulder.

The edge of roadway where the safety edge treatment is to be placed must have a solid base, free of debris such as loose material, grass, weeds, or mud. Grade areas to receive the safety edge as required.

The safety edge treatment must be placed monolithic with the adjacent lane or shoulder and shaped and compacted with a device attached to the paver.

The device must be capable of shaping and compacting HMA to the required cross section as shown. Compaction must be by constraining the HMA to reduce the cross sectional area by 10 to 15 percent. The device must produce a uniform surface texture without tearing, shoving, or gouging and must not leave marks such as ridges and indentations. The device must be capable of transition to cross roads, driveways, and obstructions.

For safety edge treatment, the angle of the slope must not deviate by more than ± 5 degrees from the angle shown. Measure the angle from the plane of the adjacent finished pavement surface.

If paving is done in multiple lifts, the safety edge treatment must be placed with each lift.

Short sections of hand work are allowed to construct transitions for safety edge treatment.

39-1.03F Widening Existing Pavement

If widening existing pavement, construct new pavement structure to match the elevation of the existing pavement's edge before placing HMA over the existing pavement.

39-1.03G Shoulders, Medians, and Other Road Connections

Until the adjoining through lane's top layer has been paved, do not pave the top layer of:

1. Shoulders
2. Tapers
3. Transitions
4. Road connections
5. Driveways
6. Curve widenings
7. Chain control lanes
8. Turnouts
9. Turn pockets

If the number of lanes changes, pave each through lane's top layer before paving a tapering lane's top layer. Simultaneous to paving a through lane's top layer, you may pave an adjoining area's top layer, including shoulders. Do not operate spreading equipment on any area's top layer until completing final compaction.

If shoulders or median borders are shown, pave shoulders and median borders adjacent to the lane before opening a lane to traffic.

If shoulder conform tapers are shown, place conform tapers concurrently with the adjacent lane's paving.

If a driveway or a road connection is shown, place additional HMA along the pavement's edge to conform to road connections and driveways. Hand rake, if necessary, and compact the additional HMA to form a smooth conform taper.

39-1.03H Leveling

Section 39-1.03H applies if a bid item for hot mix asphalt (leveling) is shown on the Bid Item List.

Fill and level irregularities and ruts with HMA before spreading HMA over the base, existing surfaces, or bridge decks. You may use mechanical equipment other than a paver for these areas. The equipment must produce uniform smoothness and texture. HMA used to change an existing surface's cross slope or profile is not paid for as hot mix asphalt (leveling).

39-1.03I Miscellaneous Areas and Dikes

Prepare the area to receive HMA for miscellaneous areas and dikes, including excavation and backfill as needed.

Spread miscellaneous areas in 1 layer and compact to the specified lines and grades.

In median areas adjacent to slotted median drains, each layer of HMA must not exceed 0.20 foot maximum compacted thickness.

The finished surface must be:

1. Textured uniformly
2. Compacted firmly
3. Without depressions, humps, and irregularities

39-1.03J Replace Asphalt Concrete Surfacing

Where replace asphalt concrete surfacing is shown, remove existing asphalt concrete surfacing and replace with HMA. The Engineer determines the exact limits of asphalt concrete surfacing to be replaced.

Replace asphalt concrete in a lane before the lane is specified to be opened to traffic.

Before removing asphalt concrete, outline the replacement area and cut neat lines with a saw or grind to full depth of the existing asphalt concrete. Do not damage asphalt concrete and base remaining in place.

If the base is excavated beyond the specified plane, replace it with HMA. The Department does not pay for this HMA.

Do not use a material transfer vehicle if replace asphalt concrete surfacing is specified.

39-1.03K–39-1.03N Reserved

39-1.03O Compaction

39-1.03O(1) General

Rolling must leave the completed surface compacted and smooth without tearing, cracking, or shoving.

If a vibratory roller is used as a finish roller, turn the vibrator off.

Do not open new HMA pavement to traffic until the surface temperature is below 130 degrees F.

If the surface to be paved is both in sunlight and shade, pavement surface temperatures are taken in the shade.

39-1.03O(2) Method Compaction

Use method compaction for any of the following conditions:

10-17-14

1. HMA pavement thickness shown is less than 0.15 foot
2. Replace asphalt concrete surfacing
3. Leveling courses
4. Areas the Engineer determines conventional compaction and compaction measurement methods are impeded

04-18-14

HMA compaction coverage is the number of passes needed to cover the paving width. A pass is 1 roller's movement parallel to the paving in either direction. Overlapping passes are part of the coverage being made and are not a subsequent coverage. Do not start a coverage until completing the prior coverage.

Method compaction must consist of performing:

1. Breakdown compaction of each layer with 3 coverages using a vibratory roller. The speed of the vibratory roller in miles per hour must not exceed the vibrations per minute divided by 1,000. If the HMA layer thickness is less than 0.08 foot, turn the vibrator off.
2. Intermediate compaction of each layer of HMA with 3 coverages using a pneumatic-tired roller at a speed not to exceed 5 mph.
3. Finish compaction of HMA with 1 coverage using a steel-tired roller.

Start rolling at the lower edge and progress toward the highest part.

The Engineer may order fewer coverages if the layer thickness of HMA is less than 0.15 foot.

39-1.03O(3)–39-1.03O(5) Reserved

39-1.03P Smoothness Corrections

If the final surface of the pavement does not comply with the smoothness specifications, grind the pavement to within specified tolerances, remove and replace it, or place an overlay of HMA. Do not start corrective work until your method is authorized.

Do not use equipment with carbide cutting teeth to grind the pavement unless authorized.

Smoothness correction of the final pavement surface must leave at least 75 percent of the specified HMA thickness. If ordered, core the pavement at the locations determined by the Engineer. Coring, including traffic control, is change order work. Remove and replace deficient pavement areas where the overlay thickness is less than 75 percent of the thickness specified as determined by the Engineer.

Corrected HMA pavement areas must be uniform rectangles with edges:

1. Parallel to the nearest HMA pavement edge or lane line
2. Perpendicular to the pavement centerline

On ground areas not to be overlaid with OGFC, apply fog seal coat under section 37-2.

Where corrections are made within areas requiring testing with inertial profiler, reprofile the entire lane length with the inertial profiler device.

Where corrections are made within areas requiring testing with a 12-foot straightedge, retest the corrected area with the straightedge.

39-1.03Q Data Cores

Section 39-1.03Q applies if a bid item for data core is shown on the Bid Item List.

Take data cores of the completed HMA pavement, underlying base, and subbase material. Notify the Engineer 3 business days before coring.

Protect data cores and surrounding pavement from damage.

Take 4-inch or 6-inch diameter data cores:

1. At the beginning, end, and every 1/2 mile within the paving limits of each route on the project
2. After all paving is complete
3. From the center of the specified lane

On a 2-lane roadway, take data cores from either lane. On a 4-lane roadway, take data cores from each direction in the outermost lane. On a roadway with more than 4 lanes, take data cores from the median lane and the outermost lane in each direction.

Each core must include the stabilized materials encountered. You may choose not to recover unstabilized material but you must identify the material. Unstabilized material includes:

1. Granular material
2. Crumbled or cracked stabilized material
3. Sandy or clayey soil

After data core summary and photograph submittal, dispose of cores.

39-1.04 PAYMENT

Geosynthetic pavement interlayer is measured by the square yard for the actual pavement area covered.

If tack coat, asphalt binder, and asphaltic emulsion are paid as separate bid items, their bid items are measured under section 92 or section 94.

The Department does not adjust the unit price for an increase or decrease in the tack coat quantity.

HMA of the type shown in the Bid Item List is measured based on the combined mixture weight. If recorded batch weights are printed automatically, the bid item for HMA is measured by using the printed batch weights, provided:

1. Total aggregate and supplemental fine aggregate weight per batch is printed. If supplemental fine aggregate is weighed cumulatively with the aggregate, the total aggregate batch weight must include the supplemental fine aggregate weight.
2. Total asphalt binder weight per batch is printed.
3. Each truckload's zero tolerance weight is printed before weighing the first batch and after weighing the last batch.
4. Time, date, mix number, load number and truck identification is correlated with a load slip.
5. Copy of the recorded batch weights is certified by a licensed weigh master and submitted.

Place hot mix asphalt dike of the type shown in the Bid Item List is measured along the completed length. Payment for the HMA used to construct the dike is not included in the payment for place hot mix asphalt dike.

Place hot mix asphalt (miscellaneous areas) is measured as the in-place compacted area. Payment for the HMA used for miscellaneous areas is not included in the payment for place hot mix asphalt (miscellaneous areas).

If replace asphalt concrete surfacing is shown, the bid item for replace asphalt concrete is measured based on the specified dimensions and any adjustments ordered.

The Department does not adjust the unit price for an increase or decrease in the prepaving grinding day quantity.

The Department reduces payment for noncompliance of HMA density based on the factors shown in the following table:

Reduced Payment Factors for Percent of Maximum Theoretical Density

HMA percent of maximum theoretical density	Reduced payment factor	HMA percent of maximum theoretical density	Reduced payment factor
91.0	0.0000	97.0	0.0000
90.9	0.0125	97.1	0.0125
90.8	0.0250	97.2	0.0250
90.7	0.0375	97.3	0.0375
90.6	0.0500	97.4	0.0500
90.5	0.0625	97.5	0.0625
90.4	0.0750	97.6	0.0750
90.3	0.0875	97.7	0.0875
90.2	0.1000	97.8	0.1000
90.1	0.1125	97.9	0.1125
90.0	0.1250	98.0	0.1250
89.9	0.1375	98.1	0.1375
89.8	0.1500	98.2	0.1500
89.7	0.1625	98.3	0.1625
89.6	0.1750	98.4	0.1750
89.5	0.1875	98.5	0.1875
89.4	0.2000	98.6	0.2000
89.3	0.2125	98.7	0.2125
89.2	0.2250	98.8	0.2250
89.1	0.2375	98.9	0.2375
89.0	0.2500	99.0	0.2500
< 89.0	Remove and replace	> 99.0	Remove and replace

39-2 TYPE A HOT MIX ASPHALT

39-2.01 GENERAL

39-2.01A Summary

Section 39-2 includes specifications for producing and placing Type A hot mix asphalt. You may produce Type A HMA using an authorized warm mix asphalt technology.

39-2.01B Definitions

Reserved

39-2.01C Submittals

39-2.01C(1) General

Reserved

39-2.01C(2) Job Mix Formula

The JMF must be based on an HMA mix design determined as described in the Superpave Mix Design SP-2 Manual by the Asphalt Institute.

39-2.01C(3) Reclaimed Asphalt Pavement

Submit QC test results for RAP gradation with the combined aggregate gradation within 2 business days of taking RAP samples during HMA production.

39-2.01C(4)–39-2.01C(6) Reserved

39-2.01D Quality Control and Assurance

39-2.01D(1) General

Reserved

39-2.01D(2) Quality Control

39-2.01D(2)(a) General

Reserved

39-2.01D(2)(b) Aggregate

Test the quality characteristics of aggregate under the test methods and frequencies shown in the following table:

Aggregate Testing Frequencies

Quality characteristic	Test method	Minimum testing frequency
Gradation ^a	AASHTO T 27	1 per 750 tons and any remaining part
Sand equivalent ^{b, c}	AASHTO T 176	
Moisture content ^d	AASHTO T 329	
Crushed particles	AASHTO T 335	1 per 10,000 tons or 2 per project whichever is greater
Los Angeles rattler	AASHTO T 96	
Flat and elongated particles	ASTM D4791	
Fine aggregate angularity	AASHTO T 304 Method A	

^aIf RAP is used, test the combined aggregate gradation under California Test 384.

^bReported value must be the average of 3 tests from a single sample.

^cUse of a sand reading indicator is required as shown in AASHTO T 176, Figure 1. Sections 4.7, 4.8, 7.1.2, 8.4.2 and 8.4.3 do not apply.

^dTest at continuous mixing plants only. If RAP is used, test the RAP moisture content at continuous mixing plant and batch mixing plant.

For lime treated aggregate, test aggregate before treatment and test for gradation and moisture content during HMA production.

39-2.01D(2)(c) Reclaimed Asphalt Pavement

10-17-14

Sample and test processed RAP at a minimum frequency of 1 sample per 1000 tons with a minimum of 6 samples per fractionated stockpile. If the fractionated stockpile has not been augmented, the 3 RAP samples taken and tested for mix design may be part of this minimum sample requirement. If a fractionated RAP stockpile is augmented, sample and test processed RAP quality characteristics at a minimum frequency of 1 sample per 500 tons of augmented RAP.

04-18-14

The combined RAP sample when tested under AASHTO T 164 must be within ± 2.0 percent of the average asphalt binder content reported on page 4 of your Contractor Hot Mix Asphalt Design Data form. If new fractionated RAP stockpiles are required, the average binder content of the new fractionated RAP stockpile must be within ± 2.0 percent of the average binder reported on page 4 of your Contractor Hot Mix Asphalt Design Data form.

The combined RAP sample when tested under AASHTO T 209 must be within ± 0.06 of the average maximum specific gravity reported on page 4 of your Contractor Hot Mix Asphalt Design Data form.

During HMA production, sample RAP twice daily and perform QC testing for:

1. Aggregate gradation at least once a day under California Test 384
2. Moisture content at least twice a day

39-2.01D(2)(d) Hot Mix Asphalt Production

Test the quality characteristics of HMA under the test methods and frequencies shown in the following table:

Hot Mix Asphalt Testing Frequencies

Quality characteristic	Test method	Minimum testing frequency
Asphalt binder content	AASHTO T 308 Method A	1 per 750 tons and any remaining part
HMA moisture content	AASHTO T 329	1 per 2,500 tons but not less than 1 per paving day
Air voids content	AASHTO T 269	1 per 4,000 tons or 2 every 5 paving days, whichever is greater
Voids in mineral aggregate	SP-2 Asphalt Mixture Volumetrics	1 per 10,000 tons or 2 per project whichever is greater
Dust proportion	SP-2 Asphalt Mixture Volumetrics	
Density of core	California Test 375	2 per paving day
Nuclear gauge density	California Test 375	3 per 250 tons or 3 per paving day, whichever is greater
Hamburg wheel track	AASHTO T 324 (Modified)	1 per 10,000 tons or 1 per project, whichever is greater
Moisture susceptibility	AASHTO T 283	

39-2.01D(3)–39-2.01D(4) Reserved

39-2.01D(5) Department Acceptance

The Department accepts Type A HMA based on compliance with:

1. Aggregate quality requirements shown in the following table:

Aggregate Quality

Quality characteristic	Test method	Requirement	
Aggregate gradation ^a	AASHTO T 27	JMF ± Tolerance	
Percent of crushed particles	AASHTO T 335		
Coarse aggregate (min, %)			
One-fractured face			95
Two-fractured faces			90
Fine aggregate (min, %)			
(Passing No. 4 sieve and retained on No. 8 sieve.)			
One fractured face			70
Los Angeles Rattler (max, %)	AASHTO T 96		
Loss at 100 Rev.			12
Loss at 500 Rev.			40
Sand equivalent (min.) ^{b, c}	AASHTO T 176	47	
Flat and elongated particles (max, % by weight at 5:1)	ASTM D4791	10	
Fine aggregate angularity (min, %) ^d	AASHTO T 304 Method A	45	

^aThe Engineer determines combined aggregate gradations containing RAP under California Test 384.

^bReported value must be the average of 3 tests from a single sample.

^cUse of a sand reading indicator is required as shown in AASHTO T 176, Figure 1. Sections 4.7, 4.8, 7.1.2, 8.4.2 and 8.4.3 do not apply.

^dThe Engineer waives this specification if HMA contains 10 percent or less of nonmanufactured sand by weight of total aggregate. Manufactured sand is fine aggregate produced by crushing rock or gravel.

2. If RAP is used, RAP quality requirements shown in the following table:

Reclaimed Asphalt Pavement Quality

Quality characteristic	Test method	Requirement
Binder content (% within the average value reported)	AASHTO T 164	±2.0
Specific gravity (within the average value reported)	AASHTO T 209	±0.06

3. In-place HMA quality requirements shown in the following table:

Type A HMA Acceptance In Place

Quality characteristic	Test method	Requirement
Asphalt binder content (%)	AASHTO T 308 Method A	JMF -0.3, +0.5
HMA moisture content (max, %)	AASHTO T 329	1
Air voids content at N _{design} (%) ^{a, b}	AASHTO T 269	4 ± 1.5
Voids in mineral aggregate on plant-produced HMA (min, %) ^a Gradation: No. 4 3/8-inch 1/2-inch 3/4-inch 1-inch with NMA ^g = 1-inch with NMA ^g = 3/4-inch	SP-2 Asphalt Mixture Volumetrics ^c	 15.5–18.5 14.5–17.5 13.5–16.5 12.5–15.5 12.5–15.5 13.5–16.5
Dust proportion	SP-2 Asphalt Mixture Volumetrics	0.6–1.3
Density of core (% of max theoretical density) ^{e, f}	California Test 375	91–97
Hamburg wheel track (min number of passes at 0.5-inch rut depth) Binder grade: PG 58 PG 64 PG 70 PG 76 or higher	AASHTO T 324 (Modified)	 10,000 15,000 20,000 25,000
Hamburg wheel track (min number of passes at inflection point) Binder grade: PG 58 PG 64 PG 70 PG 76 or higher	AASHTO T 324 (Modified)	 10,000 10,000 12,500 15,000
Moisture susceptibility (min, psi, dry strength)	AASHTO T 283	100
Moisture susceptibility (min, psi, wet strength)	AASHTO T 283	70

^aPrepare 3 briquettes. Report the average of 3 tests.

^bThe Engineer determines the bulk specific gravity of each lab-compacted briquette under AASHTO T 275, Method A, and theoretical maximum specific gravity under AASHTO T 209, Method A.

^cDetermine bulk specific gravity under AASHTO T 275, Method A.

^dThe Engineer determines the laboratory-prepared HMA value for mix design verification only.

^eThe Engineer determines percent of theoretical maximum density under California Test 375 except the Engineer uses:

1. AASHTO T 275 to determine in-place density of each density core
2. AASHTO T 209, Method A to determine theoretical maximum density instead of calculating test maximum density

^fThe Engineer determines theoretical maximum density under AASHTO T 209, Method A, at the frequency specified in California Test 375, Part 5. D.

^gNMAS means nominal maximum aggregate size.

39-2.02 MATERIALS

39-2.02A General

Reserved

39-2.02B Mix Design

The mix design must comply with the requirements shown in the following table:

Type A HMA Mix Design Requirements

Quality characteristic	Test method	Requirement
Air voids content (%)	AASHTO T 269 ^a	$N_{\text{initial}} > 8.0$ $N_{\text{design}} = 4.0$ ($N_{\text{design}} = 5.0$ for 1-inch aggregate) $N_{\text{max}} > 2.0$
Gyration compaction (no. of gyrations)	AASHTO T 312	$N_{\text{initial}} = 8$ $N_{\text{design}} = 85.0$ $N_{\text{max}} = 130$
Voids in mineral aggregate (min, %) ^b Gradation: No. 4 3/8-inch 1/2-inch 3/4-inch 1-inch with NMAS ^e = 1-inch with NMAS ^e = 3/4-inch	SP-2 Asphalt Mixture Volumetrics	 16.5–19.5 15.5–18.5 14.5–17.5 13.5–16.5 13.5–16.5 14.5–17.5
Dust proportion	SP-2 Asphalt Mixture Volumetrics	0.6–1.3
Hamburg wheel track (min number of passes at 0.5-inch rut depth) Binder grade: PG 58 PG 64 PG 70 PG 76 or higher	AASHTO T 324 (Modified) ^c	 10,000 15,000 20,000 25,000
Hamburg wheel track (min number of passes at the inflection point) Binder grade:	AASHTO T 324 (Modified) ^c	

PG 58		10,000
PG 64		10,000
PG 70		12,500
PG 76 or higher		15,000
Moisture susceptibility, dry strength (min, psi)	AASHTO T 283 ^c	100
Moisture susceptibility, wet strength (min, psi)	AASHTO T 283 ^{c, d}	70

^aCalculate the air voids content of each specimen using AASHTO T 275, Method A, to determine bulk specific gravity. Use AASHTO T 209, Method A, to determine theoretical maximum specific gravity. Use a digital manometer and pycnometer when performing AASHTO T 209.

^bMeasure bulk specific gravity using AASHTO T 275, Method A.

^cTest plant produced HMA.

^dFreeze thaw required.

^eNMAS means nominal maximum aggregate size.

For HMA mixtures using RAP, the maximum binder replacement is 25.0 percent for surface course and 40.0 percent for lower courses.

For HMA with a binder replacement percent less than or equal to 25 percent of your specified OBC, you may request that the performance graded asphalt binder grade with upper and lower temperature classifications be reduced by 6 degrees C from the specified grade.

For HMA with a binder replacement greater than 25 percent of your specified OBC and less than or equal to 40 percent of OBC, you must use a performance graded asphalt binder grade with upper and lower temperature classifications reduced by 6 degrees C from the specified grade.

39-2.02C Asphalt Binder

Reserved

39-2.02D Aggregates

39-2.02D(1) General

Before the addition of asphalt binder and lime treatment, the aggregate must comply with the requirements shown in the following table:

Aggregate Quality

Quality characteristic	Test method	Requirement
Percent of crushed particles		
Coarse aggregate (min, %)		
One-fractured face	AASHTO T 335	95
Two-fractured faces		90
Fine aggregate (min, %)		
(Passing No. 4 sieve and retained on No. 8 sieve.)		
One fractured face		70
Los Angeles Rattler (max, %)		
Loss at 100 Rev.	AASHTO T 96	12
Loss at 500 Rev.		40
Sand equivalent (min) ^{a, b}	AASHTO T 176	47
Flat and elongated particles (max, % by weight at 5:1)	ASTM D4791	10
Fine aggregate angularity (min, %) ^c	AASHTO T 304 Method A	45

^aReported value must be the average of 3 tests from a single sample.

^bUse of a Sand Reader Indicator is required as shown in AASHTO T 176, Figure 1. Sections 4.7, 4.8, 7.1.2, 8.4.2 and 8.4.3 do not apply.

^cThe Engineer waives this specification if HMA contains 10 percent or less of nonmanufactured sand by weight of total aggregate, except if your JMF fails verification. Manufactured sand is fine aggregate produced by crushing rock or gravel.

39-2.02D(2) Aggregate Gradations

The aggregate gradations for Type A HMA must comply with the requirements shown in the following table:

Aggregate Gradation Requirements

Type A HMA pavement thickness shown	Gradation
0.10 foot	3/8 inch
Greater than 0.10 to less than 0.20 foot	1/2 inch
0.20 foot to less than 0.25 foot	3/4 inch
0.25 foot or greater	3/4 inch or 1 inch

Aggregate gradation must be within the target value limits for the specified sieve size shown in the following tables:

**Aggregate Gradations
(Percentage Passing)**

1-inch

Sieve size	Target value limit	Allowable tolerance
1"	100	--
3/4"	88–93	TV ± 5
1/2"	72–85	TV ± 6
3/8"	55–70	TV ± 6
No. 4	35–52	TV ± 7
No. 8	22–40	TV ± 5
No. 30	8–24	TV ± 4
No. 50	5–18	TV ± 4
No. 200	3–7	TV ± 2

3/4-inch

Sieve size	Target value limit	Allowable tolerance
1"	100	--
3/4"	90–98	TV ± 5
1/2"	70–90	TV ± 6
No. 4	42–58	TV ± 5
No. 8	29–43	TV ± 5
No. 30	10–23	TV ± 4
No. 200	2–7	TV ± 2

1/2-inch

Sieve sizes	Target value limit	Allowable tolerance
3/4"	100	--
1/2"	95–98	TV ± 5
3/8"	72–95	TV ± 5
No. 4	52–69	TV ± 5
No. 8	35–55	TV ± 5
No. 30	15–30	TV ± 4

No. 200	2-8	TV ± 2
---------	-----	--------

3/8-inch

Sieve sizes	Target value limits	Allowable tolerance
1/2"	100	--
3/8"	95-98	TV ± 5
No. 4	55-75	TV ± 5
No. 8	30-50	TV ± 5
No. 30	15-35	TV ± 5
No. 200	2-9	TV ± 2

No. 4

Sieve sizes	Target value limits	Allowable tolerance
3/8"	100	--
No. 4	95-98	TV ± 5
No. 8	70-80	TV ± 6
No. 30	34-45	TV ± 5
No. 200	2-12	TV ± 4

39-2.02E Reclaimed Asphalt Pavement

You may substitute RAP for part of the virgin aggregate in a quantity up to a maximum of 25 percent of the aggregate blend.

Provide enough space for meeting all RAP handling requirements at your facility. Provide a clean, graded base, well drained area for stockpiles.

If RAP is from multiple sources, blend the RAP thoroughly and completely before fractionating.

For RAP substitution of 15 percent or less, fractionation is not required.

For RAP substitution greater than 15 percent, fractionate RAP stockpiles into 2 sizes, a coarse fraction RAP retained on 3/8-inch sieve, and a fine fraction RAP passing 3/8-inch sieve.

The RAP fractionation must comply with the requirements shown in the following table:

RAP Stockpile Fractionation Gradation Requirements

Quality characteristic	Test method	Requirement
Coarse (% passing the 1-inch sieve)	California Test 202 ^a	100
Fine (% passing the 3/8-inch sieve)	California Test 202 ^a	98-100

^aMaximum mechanical shaking time is 10 minutes

You may use the coarse fractionated stockpile, the fine fractionated stockpile, or a combination of the coarse and fine fractionated stockpiles.

Isolate the processed RAP stockpiles from other materials. Store processed RAP in conical or longitudinal stockpiles. Processed RAP must not be agglomerated or be allowed to congeal in large stockpiles.

39-2.02F Hot Mix Asphalt Production

10-17-14

If RAP is used, the asphalt plant must automatically adjust the virgin asphalt binder to account for RAP percentage and RAP binder.

During production, you may adjust hot or cold-feed proportion controls for virgin aggregate and RAP. RAP must be within ± 3 of RAP percentage shown in your Contractor Job Mix Formula Proposal form without exceeding 25 percent.

The aggregate temperature requirements do not apply to RAP.

39-2.03 CONSTRUCTION

Spread Type A HMA at the atmospheric and surface temperatures shown in the following table:

Minimum Atmospheric and Surface Temperatures for Type A HMA

Compacted layer thickness, feet	Atmospheric, °F		Surface, °F	
	Unmodified asphalt binder	Modified asphalt binder	Unmodified asphalt binder	Modified asphalt binder
< 0.15	55	50	60	55
≥ 0.15	45	45	50	50

For method compaction, the maximum compacted layer thickness must be 0.25 foot.

04-18-14

For Type A HMA placed under method compaction, if the asphalt binder is:

1. Unmodified, complete:
 - 1.1. 1st coverage of breakdown compaction before the surface temperature drops below 250 degrees F
 - 1.2. Breakdown and intermediate compaction before the surface temperature drops below 190 degrees F
 - 1.3. Finish compaction before the surface temperature drops below 150 degrees F
2. Modified, complete:
 - 2.1. 1st coverage of breakdown compaction before the surface temperature drops below 240 degrees F
 - 2.2. Breakdown and intermediate compaction before the surface temperature drops below 180 degrees F
 - 2.3. Finish compaction before the surface temperature drops below 140 degrees F

If you request and the Engineer authorizes, you may cool Type A HMA with water when rolling activities are complete. Apply water under section 17.

39-2.04 PAYMENT

Not Used

39-3 RUBBERIZED HOT MIX ASPHALT–GAP GRADED

39-3.01 GENERAL

39-3.01A Summary

Section 39-3 includes specifications for producing and placing rubberized hot mix asphalt–gap graded. You may produce RHMA-G using a warm mix asphalt technology.

39-3.01B Definitions

Reserved

39-3.01C Submittals

39-3.01C(1) General

10-17-14

At least 5 business days before use, submit the permit issued by the local air district for asphalt rubber binder blending equipment. If an air quality permit is not required by the local air district for producing asphalt rubber binder, submit verification from the local air district that an air quality permit is not required.

At least 10 days before RHMA-G production, submit the name of an authorized laboratory to perform QC testing for asphalt rubber binder. The authorized laboratory must comply with the Caltrans Independent Assurance Program.

04-18-14

39-3.01C(2) Job Mix Formula

With your proposed JMF include MSDS for:

1. Base asphalt binder
2. CRM and asphalt modifier
3. Blended asphalt rubber binder components

The JMF must be based on an HMA mix design determined as described in the Superpave Mix Design SP-2 Manual by the Asphalt Institute.

39-3.01C(3) Asphalt Rubber Binder

Submit a proposal for asphalt rubber binder design and profile. In the design, include the asphalt binder, asphalt modifier, and CRM and their proportions.

If you change asphalt rubber binder supplier or any component material used in asphalt rubber binder or its percentage, submit a new JMF.

For the asphalt rubber binder used, submit:

1. Log of production daily.
2. Certificate of compliance with test results for CRM and asphalt modifier with each truckload delivered to the HMA plant. The certificate of compliance for asphalt modifier must represent no more than 5,000 lb.
3. Certified weight slips for the CRM and asphalt modifier furnished.
4. QC test results on viscosity within 2 business days after sampling.
5. QC test results on cone penetration, resilience, and softening point within 3 business days after sampling.

10-17-14

Submit a certificate of compliance for the CRM and asphalt modifier. With the certificate of compliance, submit test results for CRM and asphalt modifier with each truckload delivered to the HMA plant.

04-18-14

39-3.01D Quality Control and Assurance

39-3.01D(1) General

Reserved

39-3.01D(2) Job Mix Formula Verification

If you request, the Engineer verifies RHMA-G quality requirements within 7 days of receiving all verification samples and after the JMF document submittal has been accepted.

39-3.01D(3) Quality Control

39-3.01D(3)(a) General

Reserved

39-3.01D(3)(b) Asphalt Rubber Binder

39-3.01D(3)(b)(i) General

The asphalt rubber binder blending plant must be authorized under the Department's Material Plant Quality Program.

10-17-14

Take asphalt rubber binder samples from the feed line connecting the asphalt rubber binder tank to the HMA plant.

04-18-14

39-3.01D(3)(b)(ii) Asphalt Modifier

Test asphalt modifier under the test methods and frequencies shown in the following table:

Asphalt Modifier for Asphalt Rubber Binder

Quality characteristic	Test method	Frequency
Viscosity	ASTM D445	1 per shipment
Flash point	ASTM D92	
Molecular Analysis		
Asphaltenes	ASTM D2007	1 per shipment
Aromatics	ASTM D2007	

39-3.01D(3)(b)(iii) Crumb Rubber Modifier

Sample and test scrap tire CRM and high natural CRM separately. Test CRM under the test methods and frequencies shown in the following table:

Crumb Rubber Modifier for Asphalt Rubber Binder

Quality characteristic	Test method	Frequency
Scrap tire CRM gradation	California Test 385	1 per 10,000 lb
High natural CRM gradation	California Test 385	1 per 3,400 lb
Wire in CRM	California Test 385	1 per 10,000 lb
Fabric in CRM	California Test 385	
CRM particle length	--	
CRM specific gravity	California Test 208	
Natural rubber content in high natural CRM	ASTM D297	1 per 3,400 lb

Sample and test scrap tire CRM and high natural CRM separately.

39-3.01D(3)(b)(iv) Asphalt Rubber Binder

10-17-14

Test asphalt rubber binder under the test methods and frequencies shown in the following table:

Quality characteristic	Test method	Frequency
Cone penetration	ASTM D217	1 per lot
Resilience	ASTM D5329	
Softening point	ASTM D36	
Viscosity	ASTM D7741	15 minutes before use per lot

Retain the sample from each lot. Test for cone penetration, resilience, and softening point for the first 3 lots and, if all 3 lots pass, the testing frequency may be reduced to once for every 3 lots.

If QC test results indicate that the asphalt rubber binder does not meet the specifications, take corrective action and notify the Engineer.

04-18-14

39-3.01D(3)(c) Aggregate

Test the quality characteristics of aggregate under the test methods and frequencies shown in the following table:

Aggregate Testing Frequencies

Quality characteristic	Test method	Minimum testing frequency
Gradation	AASHTO T 27	1 per 750 tons and any remaining part
Sand equivalent ^{a, b}	AASHTO T 176	
Moisture content ^c	AASHTO T 329	
Crushed particles	AASHTO T 335	1 per 10,000 tons or 2 per project, whichever is greater
Los Angeles rattler	AASHTO T 96	
Flat and elongated particles	ASTM D4791	
Fine aggregate angularity	AASHTO T 304 Method A	

^aReported value must be the average of 3 tests from a single sample.

^bUse of a sand reading indicator is required as shown in AASHTO T 176, Figure 1. Sections 4.7, 4.8, 7.1.2, 8.4.2 and 8.4.3 do not apply.

^cTest at continuous mixing plants only

For lime treated aggregate, test aggregate before treatment and test for gradation and moisture content during RHMA-G production.

39-3.01D(3)(d) Hot Mix Asphalt Production

Test the quality characteristics of RHMA-G under the test methods and frequencies shown in the following table:

RHMA-G Mix Asphalt Testing Frequencies

Quality characteristic	Test method	Minimum testing frequency
Asphalt binder content	AASHTO T 308 Method A	1 per 750 tons and any remaining part
HMA moisture content	AASHTO T 329	1 per 2,500 tons but not less than 1 per paving day
Air voids content	AASHTO T 269	1 per 4,000 tons or 2 every 5 paving days, whichever is greater
Voids in mineral aggregate	SP-2 Asphalt Mixture Volumetrics	1 per 10,000 tons or 2 per project whichever is greater
Dust proportion	SP-2 Asphalt Mixture Volumetrics	
Density of core	California Test 375	2 per paving day
Nuclear gauge density	California Test 375	3 per 250 tons or 3 per paving day, whichever is greater
Hamburg wheel track	AASHTO T 324 (Modified)	1 per 10,000 tons or 1 per project, whichever is greater
Moisture susceptibility	AASHTO T 283	

39-3.01D(4) Reserved

39-3.01D(5) Department Acceptance

39-3.01D(5)(a) General

The Department accepts RHMA-G based on compliance with:

1. Aggregate quality requirements shown in the following table:

Aggregate Quality

Quality characteristic	Test method	Requirement	
Aggregate gradation	AASHTO T 27	JMF ± Tolerance	
Percent of crushed particles	AASHTO T 335		
Coarse aggregate (min, %)			
One-fractured face			--
Two-fractured faces			90
Fine aggregate (min, %)			
(Passing No. 4 sieve and retained on No. 8 sieve.)			
One fractured face			70
Los Angeles Rattler (max, %)	AASHTO T 96		
Loss at 100 Rev.			12
Loss at 500 Rev.			40
Sand equivalent (min) ^{a, b}	AASHTO T 176	47	
Flat and elongated particles (max, % by weight at 5:1)	ASTM D4791	Report only	
Fine aggregate angularity (min, %) ^c	AASHTO T 304 Method A	45	

^aReported value must be the average of 3 tests from a single sample.

^bUse of a sand reading Indicator is required as shown in AASHTO T 176, Figure 1. Sections 4.7, 4.8, 7.1.2, 8.4.2 and 8.4.3 do not apply.

^cThe Engineer waives this specification if RHMA-G contains 10 percent or less of nonmanufactured sand by weight of total aggregate. Manufactured sand is fine aggregate produced by crushing rock or gravel.

2. In-place RHMA-G quality requirements shown in the following table:

RHMA-G In-Place Acceptance

Quality characteristic	Test method	Requirement
Asphalt binder content (%)	AASHTO T 308 Method A	JMF -0.4, +0.5
HMA moisture content (max, %)	AASHTO T 329	1
Air voids content @ N _{design} (%) ^{a, b}	AASHTO T 269	4.0 ± 1.5
Voids in mineral aggregate on laboratory-produced HMA ^d (min, %) Gradation: 1/2-inch and 3/4-inch	SP-2 Asphalt Mixture Volumetrics ^c	18.0–23.0
Voids in mineral aggregate on plant-produced HMA (min, %) ^a Gradation: 1/2-inch and 3/4-inch	SP-2 Asphalt Mixture Volumetrics ^c	18.0–23.0
Dust proportion ^a	SP-2 Asphalt Mixture Volumetrics	Report only
Density of core (% of max theoretical density) ^{e, f}	California Test 375	91–97
Hamburg wheel track (min number of passes at 0.5-inch rut depth) Binder grade: PG 58 PG 64 PG 70	AASHTO T 324 (Modified)	15,000 20,000 25,000
Hamburg wheel track (min number of passes at inflection point) Binder grade: PG 58 PG 64 PG 70	AASHTO T 324 (Modified)	10,000 12,500 15,000
Moisture susceptibility (min, psi, dry strength)	AASHTO T 283	100
Moisture susceptibility (min, psi, wet strength)	AASHTO T 283	70

^aPrepare 3 briquettes. Report the average of 3 tests.

^bThe Engineer determines the bulk specific gravity of each lab-compacted briquette under AASHTO T 275, Method A, and theoretical maximum specific gravity under AASHTO T 209, Method A.

^cDetermine bulk specific gravity under AASHTO T 275, Method A.

^dThe Engineer determines the laboratory-prepared RHMA-G value for mix design verification only.

^eThe Engineer determines percent of theoretical maximum density under California Test 375 except the Engineer uses:

1. AASHTO T 275, Method A, to determine in-place density of each density core instead of using the nuclear gauge
2. AASHTO T 209, Method A to determine theoretical maximum density instead of calculating test maximum density.

^fThe Engineer determines theoretical maximum density under AASHTO T 209, Method A, at the frequency specified in California Test 375, Part 5. D.

39-3.01D(5)(b) Asphalt Rubber Binder

39-3.01D(5)(b)(i) General

The Department does not use asphalt rubber binder design profile for production acceptance.

39-3.01D(5)(b)(ii) Asphalt Modifier

The Department accepts asphalt modifier based on compliance with the requirements shown in the following table:

Asphalt Modifier for Asphalt Rubber Binder		
Quality characteristic	Test method	Requirement
Viscosity at 100 °C ($m^2/s \times 10^{-6}$)	ASTM D445	$X \pm 3^a$
Flash point (min, °C)	ASTM D92	207
Molecular Analysis		
Asphaltenes (max, % by mass (max))	ASTM D2007	0.1
Aromatics (min % by mass)	ASTM D2007	55

^aThe symbol "X" is the asphalt modifier viscosity.

39-3.01D(5)(b)(iii) Crumb Rubber Modifier

The Department accepts scrap tire CRM and high natural CRM based on compliance with the requirements shown in the following table:

Crumb Rubber Modifier for Asphalt Rubber Binder

Quality characteristic	Test method	Requirement
Scrap tire CRM gradation (% passing No. 8 sieve)	California Test 385	100
High natural CRM gradation (% passing No. 10 sieve)	California Test 385	100
Wire in CRM (max, %)	California Test 385	0.01
Fabric in CRM (max, %)	California Test 385	0.05
CRM particle length (max, in)	--	3/16
CRM specific gravity	California Test 208	1.1–1.2

Scrap tire CRM and high natural CRM are sampled and tested separately.

39-3.01D(5)(b)(iv) Asphalt Rubber Binder

10-17-14

For Department acceptance testing, take samples in the Engineer's presence of asphalt rubber binder in 6 qt cans with open tops and friction lids. Take samples once per day or every 5 lots, whichever is greater.

The Department accepts asphalt rubber binder based on compliance with the requirements shown in the following table:

Quality characteristic	Test method	Requirement
Cone penetration at 25 °C (0.10 mm)	ASTM D217	25–70
Resilience at 25 °C (min, % rebound)	ASTM D5329	18
Softening point (°C)	ASTM D36	52–74
Viscosity at 190 °C (centipoises) ^a	ASTM D7741	1,500–4,000

^aPrepare sample for viscosity test under California Test 388.

04-18-14

39-3.01D(5)(c)–39-3.01D(5)(f) Reserved

39-3.02 MATERIALS

39-3.02A General

Reserved

39-3.02B Mix Design

For RHMA-G, the mix design must comply with the requirements shown in the following table:

RHMA-G Mix Design Requirements

Quality characteristic	Test method	Requirement
Air voids content (%)	AASHTO T 269 ^a	$N_{\text{design}} = 4.0$
Gyrations compaction (no. of gyrations)	AASHTO T 312	$N_{\text{design}} = 50\text{--}150^{\text{b}}$
Voids in mineral aggregate (min, %)	SP-2 Asphalt Mixture Volumetrics ^c	18.0–23.0
Dust proportion	SP-2 Asphalt Mixture Volumetrics	Report only
Hamburg wheel track (min number of passes at 0.5-inch rut depth) Binder grade: PG 58 PG 64 PG 70	AASHTO T 324 (Modified) ^d	 15,000 20,000 25,000
Hamburg wheel track (min number of passes at the inflection point) Binder grade: PG 58 PG 64 PG 70	AASHTO T 324 (Modified) ^d	 10,000 10,000 12,500
Moisture susceptibility, dry strength (min, psi)	AASHTO T 283 ^d	100
Moisture susceptibility, wet strength (min, psi)	AASHTO T 283 ^{d, e}	70

^aCalculate the air voids content of each specimen using AASHTO T 275, Method A, to determine bulk specific gravity and AASHTO T 209, Method A, to determine theoretical maximum specific gravity. Under AASHTO T 209 use a digital manometer and pycnometer when performing AASHTO T 209.

^bSuperpave gyratory compactor ram pressure may be increased to a maximum of 825kPa, and specimens may be held at a constant height for a maximum of 90 minutes.

^cMeasure bulk specific gravity using AASHTO T 275, Method A.

^dTest plant produced RHMA.

^eFreeze thaw required.

Determine the amount of asphalt rubber binder to be mixed with the aggregate for RHMA-G as follows:

1. Base the calculations on the average of 3 briquettes produced at each asphalt rubber binder content.
2. Plot asphalt rubber binder content versus average air voids content for each set of 3 specimens and connect adjacent points with a best-fit curve.
3. Calculate voids in mineral aggregate for each specimen, average each set, and plot the average versus asphalt rubber binder content.
4. Calculate the dust proportion and plot versus asphalt rubber binder content.
5. From the curve plotted, select the theoretical asphalt rubber binder content at 4 percent air voids.
6. At the selected asphalt rubber binder content, calculate dust proportion.
7. Record the asphalt rubber binder content in the Contractor Hot Mix Asphalt Design Data Form as the OBC.

The OBC must not fall below 7.5 percent by total weight of the mix.

Laboratory mixing and compaction must comply with AASHTO R 35, except the mixing temperature of the aggregate must be between 300 and 325 degrees F. The mixing temperature of the asphalt rubber binder must be between 375 and 425 degrees F. The compaction temperature of the combined mixture must be between 290 and 320 degrees F.

39-3.02C Asphalt Rubber Binder

39-3.02C(1) General

Asphalt rubber binder must be a combination of:

1. Asphalt binder
2. Asphalt modifier
3. CRM

The combined asphalt binder and asphalt modifier must be 80.0 ± 2.0 percent by weight of the asphalt rubber binder.

39-3.02C(2) Asphalt Modifier

Asphalt modifier must be a resinous, high flash point, and aromatic hydrocarbon, and must comply with the requirements shown in the following table:

Asphalt Modifier for Asphalt Rubber Binder

Quality characteristic	Test method	Requirement
Viscosity at 100 °C (m ² /s x 10 ⁻⁶)	ASTM D445	X ± 3 ^a
Flash point (min, °C)	ASTM D92	207
Molecular Analysis		
Asphaltenes (max, % by mass)	ASTM D2007	0.1
Aromatics (min, % by mass)	ASTM D2007	55

^aThe symbol "X" is the proposed asphalt modifier viscosity. "X" must be between 19 and 36. A change in "X" requires a new asphalt rubber binder design.

Asphalt modifier must be from 2.0 to 6.0 percent by weight of the asphalt binder in the asphalt rubber binder.

39-3.02C(3) Crumb Rubber Modifier

CRM must be a ground or granulated combination of scrap tire CRM and high natural CRM. CRM must be 75.0 ± 2.0 percent scrap tire CRM and 25.0 ± 2.0 percent high natural CRM by total weight of CRM. Scrap tire CRM must be from any combination of automobile tires, truck tires, or tire buffings.

The CRM must comply with the requirements shown in the following table:

Crumb Rubber Modifier for Asphalt Rubber Binder

Quality characteristic	Test method	Requirement
Scrap tire CRM gradation (% passing No. 8 sieve)	California Test 385	100
High natural CRM gradation (% passing No. 10 sieve)	California Test 385	100
Wire in CRM (max, %)	California Test 385	0.01
Fabric in CRM (max, %)	California Test 385	0.05
CRM particle length (max, in) ^a	--	3/16
CRM specific gravity	California Test 208	1.1–1.2
Natural rubber content in high natural CRM (%)	ASTM D297	40.0–48.0

^aTest at mix design and for certificate of compliance.

CRM must be ground or granulated at ambient temperature. If steel and fiber are cryogenically separated, separation must occur before grinding or granulating. Cryogenically produced CRM particles must be ground or granulated and not pass through the grinder or granulator.

CRM must be dry, free-flowing particles that do not stick together. CRM must not cause foaming when combined with the asphalt binder and asphalt modifier. You may add calcium carbonate or talc up to 3 percent by weight of CRM.

39-3.02C(4) Design and Profile

Design the asphalt rubber binder from testing you perform for each quality characteristic and for the reaction temperatures expected during production. The profile must include the same component sources for the asphalt rubber binder used. The 24-hour (1,440-minute) interaction period determines the design profile. At a minimum, mix asphalt rubber binder components, take samples, and perform and record the tests shown in the following table:

Asphalt Rubber Binder Reaction Design Profile

Quality characteristic	Test Method	Minutes of reaction ^a							Limits
		45	60	90	120	240	360	1440	
Cone penetration at 25 °C (0.10 mm)	ASTM D217	X ^b				X		X	25–70
Resilience at 25 °C (min, % rebound)	ASTM D5329	X				X		X	18
Field softening point (°C)	ASTM D36	X				X		X	52–74
Viscosity (centipoises)	ASTM D7741	X	X	X	X	X	X	X	1,500–4,000

^aSix hours (360 minutes) after CRM addition, reduce the oven temperature to 275 °F for 16 hours. After the 16-hour (960 minutes) cool down after CRM addition, reheat the binder to the reaction temperature expected during production for sampling and testing at 24 hours (1,440 minutes).

^b"X" denotes required testing

39-3.02C(5) Asphalt Rubber Binder Production

39-3.02C(5)(a) General

Deliver scrap tire CRM and high natural CRM in separate bags.

39-3.02C(5)(b) Mixing

Proportion and mix asphalt binder, asphalt modifier, and CRM simultaneously or premix the asphalt binder and asphalt modifier before adding CRM. If you premix asphalt binder and asphalt modifier, mix them for at least 20 minutes. When you add CRM, the asphalt binder and asphalt modifier must be from 375 to 440 degrees F.

After interacting for at least 45 minutes, the quality characteristics of asphalt rubber binder must comply with the requirements shown in the following table:

10-17-14

Quality characteristic	Test method	Requirement
Cone penetration at 25 °C (0.10 mm)	ASTM D217	25–70
Resilience at 25 °C (min, % rebound)	ASTM D5329	18
Softening point (°C)	ASTM D36	52–74
Viscosity at 190 °C (centipoises) ^a	ASTM D7741	1,500–4,000

^aPrepare sample for viscosity test under California Test 388.

Do not use asphalt rubber binder during the first 45 minutes of the reaction period. During this period, the asphalt rubber binder mixture must be between 375 degrees F and the lower of 425 or 25 degrees F below the asphalt binder's flash point indicated in the MSDS.

If any asphalt rubber binder is not used within 4 hours after the reaction period, discontinue heating. If the asphalt rubber binder drops below 375 degrees F, reheat before use. If you add more scrap tire CRM to the reheated asphalt rubber binder, the binder must undergo a 45-minute reaction period. The added scrap tire CRM must not exceed 10 percent of the total asphalt rubber binder weight. Reheated and reacted asphalt rubber binder must comply with the viscosity specifications. Do not reheat asphalt rubber binder more than twice.

39-3.02D Aggregates

39-3.02D(1) General

For RHMA-G, before the addition of asphalt binder and lime treatment, the aggregate must comply with the requirements shown in the following table:

Aggregate Quality

Quality characteristic	Test method	Requirement	
Percent of crushed particles	AASHTO T 335		
Coarse aggregate (min, %)			
One-fractured face			--
Two-fractured faces			90
Fine aggregate (min, %)			
(Passing No. 4 sieve and retained on No. 8 sieve.)	AASHTO T 335	70	
One fractured face			
Los Angeles Rattler (max, %)	AASHTO T 96		
Loss at 100 Rev.			12
Loss at 500 Rev.			40
Sand equivalent (min) ^{a, b}	AASHTO T 176	47	
Flat and elongated particles (max, % by weight at 5:1)	ASTM D4791	Report only	
Fine aggregate angularity (min, %) ^c	AASHTO T 304 Method A	45	

^aReported value must be the average of 3 tests from a single sample.

^bUse of a sand reading indicator is required as shown in AASHTO T 176, Figure 1. Sections 4.7, 4.8, 7.1.2, 8.4.2 and 8.4.3 do not apply.

^cThe Engineer waives this specification if HMA contains 10 percent or less of nonmanufactured sand by weight of total aggregate, except if your JMF fails verification. Manufactured sand is fine aggregate produced by crushing rock or gravel.

39-3.02D(2) Aggregate Gradations

The aggregate gradations for RHMA-G must comply with the requirements shown in the following table:

10-17-14

Aggregate Gradation Requirements

Type A HMA pavement thickness shown	Gradation
0.10 to less than 0.20 foot	1/2 inch
0.20 foot or greater	3/4 inch

04-18-14

For RHMA-G, the aggregate gradations must be within the target value limits for the specified sieve size shown in the following tables:

Aggregate Gradation

(Percentage Passing)

Rubberized Hot Mix Asphalt - Gap Graded (RHMA-G)

3/4-inch RHMA-G

Sieve Sizes	Target Value Limits	Allowable Tolerance
1"	100	--
3/4"	95-98	TV ± 5
1/2"	83-87	TV ± 6
3/8"	65-70	TV ± 5
No. 4	28-42	TV ± 6
No. 8	14-22	TV ± 5
No. 200	0-6	TV ± 2

1/2-inch RHMA-G

Sieve Sizes	Target Value Limits	Allowable Tolerance
3/4"	100	--
1/2"	90-98	TV ± 6
3/8"	83-87	TV ± 5
No. 4	28-42	TV ± 6
No. 8	14-22	TV ± 5
No. 200	0-6	TV ± 2

39-3.02E Rubberized Hot Mix Asphalt Production

Asphalt rubber binder must be from 375 to 425 degrees F when mixed with aggregate.

If the dry and wet moisture susceptibility test result for treated plant-produced RHMA-G is less than the RHMA-G mix design requirement for dry and wet moisture susceptibility strength, the minimum dry and wet strength requirement is waived, but you must use one of the following treatments:

1. Aggregate lime treatment using the slurry method
2. Aggregate lime treatment using the dry lime method
3. Liquid antistrip treatment of HMA

39-3.03 CONSTRUCTION

Use a material transfer vehicle when placing RHMA-G.

Do not use a pneumatic tired roller to compact RHMA-G.

10-17-14

Spread and compact RHMA-G at an atmospheric temperature of at least 55 degrees F and a surface temperature of at least 60 degrees F.

If the atmospheric temperature is below 70 degrees F, cover loads in trucks with tarps. The tarps must completely cover the exposed load until you transfer the mixture to the paver's hopper or to the pavement surface. Tarps are not required if the time from discharge to truck until transfer to the paver's hopper or the pavement surface is less than 30 minutes.

For RHMA-G placed under method compaction:

1. Complete the 1st coverage of breakdown compaction before the surface temperature drops below 285 degrees F.
2. Complete breakdown and intermediate compaction before the surface temperature drops below 250 degrees F. Use a static steel-tired roller instead of the pneumatic-tired roller for intermediate compaction.
3. Complete finish compaction before the surface temperature drops below 200 degrees F.

04-18-14

Spread sand at a rate between 1 and 2 lb/sq yd on new RHMA-G pavement when finish rolling is complete. Sand must be free of clay or organic matter. Sand must comply with section 90-1.02C(3). Keep traffic off the pavement until spreading sand is complete.

39-3.04 PAYMENT

Not Used

39-4 OPEN GRADED FRICTION COURSES

39-4.01 GENERAL

39-4.01A Summary

Section 39-4 includes specifications for producing and placing open graded friction courses. Open graded friction courses include HMA-O, RHMA-O, and RHMA-O-HB.

You may produce OGFC using a warm mix asphalt technology.

39-4.01B Definitions

Reserved

39-4.01C Submittals

Submit a complete JMF, except do not specify an asphalt binder content.

39-4.01D Quality Control and Assurance

39-4.01D(1) General

Reserved

39-4.01D(2) Quality Control

39-4.01D(2)(a) General

Reserved

39-4.01D(2)(b) Asphalt Rubber Binder

For RHMA-O and RHMA-O-HB, the asphalt rubber binder must comply with the specifications in 39-3.01D(2)(b).

39-4.01D(2)(c) Aggregate

Test the quality characteristics of aggregate under the test methods and frequencies shown in the following table:

Aggregate Testing Frequencies

Quality characteristic	Test method	Minimum testing frequency
Gradation	AASHTO T 27	1 per 750 tons and any remaining part
Moisture content ^a	AASHTO T 329	1 per 1500 tons and any remaining part
Crushed particles	AASHTO T 335	1 per 10,000 tons or 2 per project, whichever is greater
Los Angeles rattler	AASHTO T 96	
Flat and elongated particles	ASTM D4791	

^aTest at continuous mixing plants only

For lime treated aggregate, test aggregate before treatment and test for gradation and moisture content during OGFC production.

39-4.01D(2)(d) Hot Mix Asphalt Production

Test the quality characteristics of OGFC under the test methods and frequencies shown in the following table:

OGFC Testing Frequencies

Quality characteristic	Test method	Minimum testing frequency
Asphalt binder content	AASHTO T 308 Method A	1 per 750 tons and any remaining part
HMA moisture content	AASHTO T 329	1 per 2,500 tons but not less than 1 per paving day

39-4.01D(3) Department Acceptance

39-4.01D(3)(a) General

The Department accepts OGFC based on compliance with:

1. Aggregate quality requirements shown in the following table:

Aggregate Quality		
Quality characteristic	Test method	Requirement
Aggregate gradation	AASHTO T 27	JMF ± Tolerance
Percent of crushed particles	AASHTO T 335	90
Coarse aggregate (min, %)		
One-fractured face		
Two-fractured faces		
Fine aggregate (min, %)	AASHTO T 335	90
(Passing No. 4 sieve and retained on No. 8 sieve.)		
One fractured face		90
Los Angeles Rattler (max, %)	AASHTO T 96	12
Loss at 100 Rev.		
Loss at 500 Rev.		
Flat and elongated particles (max, % by weight @ 5:1)	ASTM D4791	Report only

2. In-place OGFC quality requirements shown in the following table:

OGFC Acceptance In Place		
Quality characteristic	Test method	Requirement
Asphalt binder content (%)	AASHTO T 308 Method A	JMF -0.4, +0.5
HMA moisture content (max, %)	AASHTO T 329	1

39-4.01D(3)(b) Asphalt Rubber Binder

The Department accepts asphalt rubber binder in RHMA-O and RHMA-O-HB under 39-3.01D(5)(b).

39-4.01D(3)(c) Pavement Smoothness

Pavement smoothness of OGFC must comply with the Mean Roughness Index requirements shown in the following table for a 0.1 mile section:

OGFC Pavement Smoothness Acceptance Criteria

OGFC placement on	Mean Roughness Index requirement
New construction or HMA overlay	60 in/mi or less
Existing pavement	75 in/mi or less
Milled surface	75 in/mi or less

39-4.01D(3)(d)–39-4.01D(3)(f) Reserved

39-4.02 MATERIALS

39-4.02A General

When mixed with asphalt binder, aggregate must not be more than 325 degrees F except aggregate for OGFC with unmodified asphalt binder must be not more than 275 degrees F.

39-4.02B Mix Design

The Department determines the asphalt binder content under California Test 368 within 20 days of your complete JMF submittal and provides you a Caltrans Hot Mix Asphalt Verification form.

For OGFC, the 1st paragraph of section 39-1.02B(1) does not apply.

39-4.02C Asphalt Binder

Asphalt rubber binder in RHMA-O and RHMA-O-HB must comply with section 39-3.02B.

39-4.02D Aggregate

39-4.02D(1) General

Aggregate must comply with the requirements shown in the following table:

Aggregate Quality

Quality characteristic	Test method	Requirement	
Percent of crushed particles	AASHTO T 335		
Coarse aggregate (min, %)			
One-fractured face			--
Two-fractured faces			90
Fine aggregate (min, %)			
(Passing No. 4 sieve and retained on No. 8 sieve.)			
One fractured face		90	
Los Angeles Rattler (max, %)	AASHTO T 96		
Loss at 100 Rev.			12
Loss at 500 Rev.			40
Flat and elongated particles (max, % by weight at 5:1)	ASTM D4791	Report only	

39-4.02D(2) Aggregate Gradations

10-17-14

The aggregate gradations for HMA-O must comply with the requirements shown in the following table:

Aggregate Gradation Requirements

HMA-O pavement thickness shown	Gradation
0.10 foot or greater to less than 0.15 foot	1/2 inch
0.15 foot or greater	1 inch

The aggregate gradations for RHMA-O and RHMA-O-HB must comply with the requirements shown in the following table:

Aggregate Gradation Requirements

RHMA-O and RHMA-O-HB pavement thickness shown	Gradation
0.10 foot or greater	1/2 inch

04-18-14

For RHMA-O and RHMA-O-HB, the 1-inch aggregate gradation is not allowed.

For OGFC, the aggregate gradations must be within the target value limits for the specified sieve size shown in the following tables:

**Aggregate Gradations
(Percentage Passing)
Open Graded Friction Course (OGFC)**

1-inch OGFC

Sieve size	Target value limit	Allowable tolerance
1 1/2"	100	--
1"	99–100	TV ± 5
3/4"	85–96	TV ± 5
1/2"	55–71	TV ± 6
No. 4	10–25	TV ± 7
No. 8	6–16	TV ± 5
No. 200	0–6	TV ± 2

1/2-inch OGFC

Sieve size	Target value limit	Allowable tolerance
3/4"	100	--
1/2"	95–100	TV ± 6
3/8"	78–89	TV ± 6
No. 4	28–37	TV ± 7
No. 8	7–18	TV ± 5
No. 30	0–10	TV ± 4
No. 200	0–3	TV ± 2

If lime treatment is required, you may reduce the lime ratio for the combined aggregate from 1.0 to 0.5 percent for OGFC.

39-4.03 CONSTRUCTION

Use a material transfer vehicle when placing OGFC.

If the atmospheric temperature is below 70 degrees F, cover loads in trucks with tarps. The tarps must completely cover the exposed load until you transfer the mixture to the paver's hopper or to the pavement surface. Tarps are not required if the time from discharge to truck until transfer to the paver's hopper or the pavement surface is less than 30 minutes.

Apply a tack coat before placing OGFC. The tack coat application rate must comply with the requirements of the following table:

Tack Coat Application Rates for OGFC

OGFC over:	Minimum Residual Rates (gal/sq yd)		
	CSS1/CSS1h, SS1/SS1h and QS1h/CQS1h Asphaltic Emulsion	CRS1/CRS2, RS1/RS2 and QS1/CQS1 Asphaltic Emulsion	Asphalt Binder and PMRS2/PMCRS2 and PMRS2h/PMCRS2h Asphaltic Emulsion
New HMA	0.03	0.04	0.03
PCC and existing AC surfacing	0.05	0.06	0.04
Planed pavement	0.06	0.07	0.05

Compact OGFC with steel-tired, 2-axle tandem rollers. If placing over 300 tons of OGFC per hour, use at least 3 rollers for each paver. If placing less than 300 tons of OGFC per hour, use at least 2 rollers for each paver. Each roller must weigh between 126 to 172 lb per linear inch of drum width. Turn the vibrator off.

Compact OGFC with 2 coverages. The Engineer may order fewer coverages if the layer thickness of OGFC is less than 0.20 foot.

For HMA-O with unmodified asphalt binder:

1. Spread and compact only if the atmospheric temperature is at least 55 degrees F and the surface temperature is at least 60 degrees F.
2. Complete the 1st coverage using 2 rollers before the surface temperature drops below 240 degrees F.
3. Complete all compaction before the surface temperature drops below 200 degrees F.

For HMA-O with modified asphalt binder except asphalt rubber binder:

1. Spread and compact only if the atmospheric temperature is at least 50 degrees F and the surface temperature is at least 50 degrees F.
2. Complete the 1st coverage using 2 rollers before the surface temperature drops below 240 degrees F.
3. Complete all compaction before the surface temperature drops below 180 degrees F.

For RHMA-O and RHMA-O-HB:

1. Spread and compact only if the atmospheric temperature is at least 55 degrees F and surface temperature is at least 60 degrees F.
2. Complete the 1st coverage using 2 rollers before the surface temperature drops below 280 degrees F.
3. Complete compaction before the surface temperature drops below 250 degrees F.

Spread sand at a rate between 1 and 2 lb/sq yd on new RHMA-O and RHMA-O-HB pavement when finish rolling is complete. Sand must be free of clay or organic matter. Sand must comply with section 90-1.02C(3). Keep traffic off the pavement until spreading sand is complete.

If you choose to correct OGFC for smoothness, the Engineer determines if the corrective method causes raveling. OGFC that is raveling must be removed and replaced.

39-4.04 PAYMENT

Not Used

39-5 BONDED WEARING COURSES

39-5.01 GENERAL

39-5.01A General

39-5.01A(1) Summary

Section 39-5 includes specifications for producing and placing bonded wearing courses.

BWC includes placing a polymer modified asphaltic emulsion and the specified HMA in a single pass with an integrated paving machine.

BWC using RHMA-G, RHMA-O, or HMA-O must comply with the specifications for RHMA-G, RHMA-O, or HMA-O.

39-5.01A(2) Definitions

Reserved

39-5.01A(3) Submittals

With your JMF submittal, include:

1. Asphaltic emulsion membrane target residual rate
2. Weight ratio of water to bituminous material in the original asphaltic emulsion

Within 3 business days following the 1st job site delivery, submit test results for asphaltic emulsion properties performed on a sample taken from the asphaltic emulsion delivered.

Within 1 business day of each job site delivery of asphaltic emulsion, submit to METS a 2-quart sample and a certificate of compliance. Ship each sample so that it is received at METS within 48 hours of sampling.

Each day BWC is placed, submit the residual and application rate for the asphaltic emulsion membrane.

During production, submit certified volume or weight slips for the materials supplied.

39-5.01A(4) Quality Control and Assurance

39-5.01A(4)(a) General

For each job site delivery of asphaltic emulsion, take a 2-quart sample in the presence of the Engineer. Take samples from the delivery truck at mid-load from a sampling tap or thief. If the sample is taken from the tap, draw and discard 4 quarts before sampling.

If you unload asphalt binder or asphaltic emulsion into a bulk storage tank, do not use material from the tank until you submit test results for a sample taken from the bulk storage tank. Testing must be performed by an AASHTO-accredited laboratory.

39-5.01A(4)(b) Quality Control

Sample BWC in two 1-gallon metal containers.

The asphaltic emulsion membrane must be tested under ASTM D2995 at least once per paving day at the job site.

39-5.01A(4)(c) Department Acceptance

The Department accepts asphaltic emulsion membrane based on compliance with the requirements shown in the following table:

10-17-14

Asphaltic Emulsion Membrane		
Quality characteristic	Test method	Requirement
Saybolt Furol Viscosity at 25 °C (SFS) ^a	AASHTO T 59	20–100
Sieve test on original emulsion at time of delivery (max, %)	AASHTO T 59	0.05
24-hour storage stability (max, %)	AASHTO T 59	1
Residue by evaporation (min, %)	California Test 331	63
Tests on residue from evaporation test:		
Torsional recovery, measure entire arc of recovery at 25 °C (min, %)	California Test 332	40
Penetration at 25 °C (0.01 mm)	AASHTO T 49	70–150

^aSFS means Saybolt Furol seconds

04-18-14

The Department accepts the BWC based on the submitted asphaltic emulsion membrane target residual rate ± 0.02 gal/sq yd when tested under ASTM D2995.

39-5.01B Materials

39-5.01B(1) General

Reserved

39-5.01B(2) Asphaltic Emulsion Membrane

The asphaltic emulsion membrane must comply with the requirements shown in the following table:

Asphaltic Emulsion Membrane

Quality characteristic	Test method	Requirement
Saybolt Furol Viscosity at 25 °C (SFS) ^a	AASHTO T 59	20–100
Sieve test on original emulsion at time of delivery (max, %)	AASHTO T 59	0.05
24-hour storage stability (max, %)	AASHTO T 59	1
Residue by evaporation (min, %)	California Test 331	63
Tests on residue from evaporation test:		
Torsional recovery, measure entire arc of recovery at 25 °C (min, %)	California Test 332	40
Penetration at 25 °C (0.01 mm)	AASHTO T 49	70–150

^a SFS means Saybolt Furol seconds

04-18-14

39-5.01B(3) Reserved

39-5.01C Construction

39-5.01C(1) General

Use method compaction for BWC.

Do not dilute the asphaltic emulsion.

Do not place BWC if rain is forecast for the project area within 24 hours by the National Weather Service.

39-5.01C(2) Spreading and Compacting Equipment

Use a material transfer vehicle when placing BWC.

Use an integrated distributor paver capable of spraying the asphaltic emulsion membrane, spreading the HMA, and leveling the mat surface in 1 pass.

Apply asphaltic emulsion membrane at a uniform rate for the full paving width. The asphaltic emulsion membrane must not be touched by any part of the paver including wheels or tracks.

If the spray bar is adjusted for changing pavement widths, the paver must prevent excess spraying of asphaltic emulsion beyond 2 inches of the HMA edge.

39-5.01C(3) Applying Asphaltic Emulsion

10-17-14

Before spreading HMA, apply asphaltic emulsion membrane on dry or damp pavement with no free water.

04-18-14

Apply emulsion at a temperature from 120 to 180 degrees F and in a single application at the residual rate specified for the condition of the underlying surface. Asphaltic emulsion membrane must have a target residual rate for the surfaces to receive the emulsion as shown in the following table:

Asphaltic Emulsion Membrane Target Residual Rate

Surface to receive asphaltic emulsion membrane	Target residual rates (gal/sq yd)
PCC pavement	0.09–0.11
Dense, compacted, new HMA pavement	0.11–0.14
Open textured, dry, aged or oxidized existing AC pavement	0.13–0.17

If requested and authorized, you may change the asphaltic emulsion membrane application rates.

39-5.01C(4) Placing and Compacting Hot Mix Asphalt

Construct a transverse joint if the HMA remains in the paver for more than 30 minutes.

Do not reintroduce HMA spread over asphaltic emulsion membrane into the paving process.

Do not overlap or hot lap HMA. Pave through lanes after paving adjacent:

1. Shoulders
2. Tapers
3. Transitions
4. Road connections
5. Driveways
6. Curve widenings
7. Chain control lanes
8. Turnouts
9. Turn pockets
10. Ramps

For BWC placed on areas adjacent to through lanes that extend into the through lanes, cut the BWC to a neat, straight vertical line at the lane line.

If you spill asphaltic emulsion into the paver hopper, stop paving and remove the contaminated material.

39-5.01D Payment

Not Used

39-5.02 BONDED WEARING COURSES-GAP GRADED

39-5.02A General

39-5.02A(1) Summary

Section 39-5.02 includes specifications for producing bonded wearing course-gap graded.

39-5.02A(2) Definitions

Reserved

39-5.02A(3) Submittals

Include film thickness and calculations and AASHTO T 305 results with your JMF submittal.

39-5.02A(4) Quality Control and Assurance

39-5.02A(4)(a) General

Reserved

39-5.02A(4)(b) Quality Control

39-5.02A(4)(b)(i) General

Reserved

39-5.02A(4)(b)(ii) Aggregate

Test the quality characteristics of aggregate under the test methods and frequencies shown in the following table:

Aggregate Testing Frequencies

Quality characteristic	Test method	Minimum testing frequency
Gradation	AASHTO T 27	1 per 750 tons and any remaining part
Sand equivalent ^{a, b}	AASHTO T 176	
Moisture content ^c	AASHTO T 329	1 per 1500 tons and any remaining part
Crushed particles	AASHTO T 335	1 per 10,000 tons or 2 per project, whichever is greater
Los Angeles rattler	AASHTO T 96	
Flat and elongated particles	ASTM D4791	
Fine aggregate angularity	AASHTO T 304 Method A	

^aReported value must be the average of 3 tests from a single sample.

^bUse of a sand reading indicator is required as shown in AASHTO T 176, Figure 1. Sections 4.7, 4.8, 7.1.2, 8.4.2, and 8.4.3 do not apply.

^cTest at continuous mixing plants only.

For lime treated aggregate, test aggregate before treatment and test for gradation and moisture content during BWC-G production.

39-5.02A(4)(b)(iii) Hot Mix Asphalt Production

Sample BWC in two 1-gallon metal containers.

Test the quality characteristics of BWC-G under the test methods and frequencies shown in the following table:

BWC-G Testing Frequencies

Quality characteristic	Test method	Minimum testing frequency
Asphalt binder content	AASHTO T 308 Method A	1 per 750 tons and any remaining part
HMA moisture content	AASHTO T 329	1 per 2,500 tons but not less than 1 per paving day

39-5.02A(4)(b)(iv)–39-5.02A(4)(b)(vii) Reserved

39-5.02A(4)(c) Department Acceptance

The Department accepts BWC-G based on compliance with:

1. Asphalt binder content at JMF -0.4, +0.5 percent when tested under AASHTO T 308, Method A.
2. Aggregate quality requirements shown in the following table:

Aggregate Quality

Quality characteristic	Test method	Requirement	
Aggregate gradation	AASHTO T 27	JMF ± Tolerance	
Percent of crushed particles	AASHTO T 335	90	
Coarse aggregate (min, %)			
One-fractured face			--
Two-fractured faces			90
Fine aggregate (min, %)	AASHTO T 335	85	
(Passing No. 4 sieve and retained on No. 8 sieve.)			
One fractured face			
Los Angeles Rattler (max, %)	AASHTO T 96	12	
Loss at 100 Rev.			
Loss at 500 Rev.			35
Sand equivalent (min)	AASHTO T 176	47	
Flat and elongated particles (max, % by weight at 5:1)	ASTM D4791	25	
Fine aggregate angularity (min, %)	AASHTO T 304 Method A	45	

^aReported value must be the average of 3 tests from a single sample.

^bUse of a sand reading indicator is required as shown in AASHTO T 176, Figure 1. Sections 4.7, 4.8, 7.1.2, 8.4.2 and 8.4.3 do not apply.

39-5.02B Materials

39-5.02B(1) General

Reserved

39-5.02B(2) Mix Design

For BWC-G, the 1st paragraph of section 39-1.02B(1) does not apply.

Determine the proposed OBC from a mix design that complies with the requirements shown in the following table:

Hot Mix Asphalt Mix Design Requirements

Quality characteristic	Test method	Requirement
Film thickness (min, μm)	Asphalt Institute MS-2 Table 6.1 ^a	12
Drain down (max, %)	AASHTO T 305 ^b	0.1

^a Film thickness is calculated based on the effective asphalt content and determined as follows:

$$FT = \left(\frac{P_{be}}{SA \times G_b \times 1000} \right) 10^6$$

Where:

FT = Film thickness in μm

P_{be} = Effective asphalt content by total weight of mix using SP-2 Asphalt Mixture

SA = Estimated surface area of the aggregate blend in m²/kg from Table 6.1 in the Asphalt Institute Manual Series No. 2 (MS-2).

G_b = Specific gravity of asphalt binder

^b Combine aggregate and asphalt at the asphalt binder supplier's instructed mixing temperature. Coated aggregates that fall through the wire basket during loading must be returned to the basket before conditioning at 350 °F for 1 hour.

The OBC must be greater than 4.9 percent by total weight of mix.

39-5.02B(3) Asphalt Binder

Reserved

39-5.02B(4) Aggregate

The aggregate must comply with the requirements shown in the following table:

Aggregate Quality

Quality characteristic	Test method	Requirement
Percent of crushed particles		
Coarse aggregate (min, %)		
One-fractured face	AASHTO T 335	--
Two-fractured faces		90
Fine aggregate (min, %)		
(Passing No. 4 sieve and retained on No. 8 sieve.)		
One fractured face		85
Los Angeles Rattler (max, %)		
Loss at 100 Rev.	AASHTO T 96	12
Loss at 500 Rev.		35
Sand equivalent (min)	AASHTO T 176	47
Flat and elongated particles (max, % by weight @ 5:1)	ASTM D4791	25
Fine aggregate angularity (min, %)	AASHTO T 304 Method A	45

^aReported value must be the average of 3 tests from a single sample.

^bUse of a sand reading indicator is required as shown in AASHTO T 176, Figure 1. Sections 4.7, 4.8, 7.1.2, 8.4.2 and 8.4.3 do not apply.

The aggregate gradations for BWC-G must comply with the requirements shown in the following table:

10-17-14

Aggregate Gradation Requirements

BWC-G pavement thickness shown	Gradation
less than 0.08 foot	No. 4 or 3/8 inch
0.08 foot or greater	1/2 inch

04-18-14

The proposed aggregate gradation must be within the TV limits for the specified sieve sizes shown in the following tables:

**Aggregate Gradation
(Percentage Passing)
Bonded Wearing Course—Gap Graded**

1/2-inch BWC-G

Sieve sizes	Target value limits	Allowable tolerance
3/4"	100	--
1/2"	80–100	TV ± 6
3/8"	55–80	TV ± 6
No. 4	25–40	TV ± 7
No. 8	19–32	TV ± 5
No. 16	16–22	TV ± 5
No. 30	10–18	TV ± 4
No. 50	8–13	TV ± 4
No. 100	6–10	TV ± 2
No. 200	4.0–7.0	TV ± 2

3/8-inch BWC-G

Sieve sizes	Target value limits	Allowable tolerance
1/2"	100	--
3/8"	80–100	TV ± 6
No. 4	25–40	TV ± 7
No. 8	19–32	TV ± 5
No. 16	16–22	TV ± 5
No. 30	10–18	TV ± 4
No. 50	8–13	TV ± 4
No. 100	7–11	TV ± 2
No. 200	6.0–10.0	TV ± 2

No. 4 BWC-G

Sieve sizes	Target value limits	Allowable tolerance
1/2"	100	--
3/8"	95–100	TV ± 2
No. 4	42–55	TV ± 7
No. 8	19–32	TV ± 5
No. 16	16–22	TV ± 5

No. 30	10–18	TV ± 4
No. 50	8–13	TV ± 4
No. 100	7–11	TV ± 2
No. 200	6.0–10.0	TV ± 2

39-5.02C Construction

10-17-14

Apply asphaltic emulsion when the atmospheric and pavement temperatures are above:

1. 50 degrees F if PG 76-22 M is specified
2. 45 degrees F if PG 64-28 M is specified

04-18-14

39-5.02D Payment

Not Used

39-6 HOT MIX ASPHALT ON BRIDGE DECKS

39-6.01 GENERAL

Section 39-6 includes specifications for producing and placing hot mix asphalt on bridge decks. HMA used for bridge decks must comply with the specifications for Type A HMA in section 39-2.

39-6.02 MATERIALS

Do not use the 1-inch or 3/4-inch aggregate gradation for HMA on bridge decks. The grade of asphalt binder for HMA must be PG 64-10 or PG 64-16.

39-6.03 CONSTRUCTION

Spread and compact HMA on bridge decks using method compaction.

If a concrete expansion dam is to be placed at a bridge deck expansion joint, tape oil-resistant construction paper to the deck over the area to be covered by the dam before placing the tack coat and HMA across the joint.

Apply tack coat at the minimum residual rate specified in section 39-1.03C(5). For HMA placed on a deck seal, use the minimum residual rate specified for PCC.

For HMA placed on a deck seal:

1. Place the HMA within 7 days after installing the deck seal.
2. If a paper mask is placed on the deck under section 54-5.03, place the HMA continuously across the paper mask.
3. Place HMA in at least 2 approximately equal layers.
4. For placement of the 1st HMA layer:
 - 4.1. Comply with the HMA application temperature recommended by the deck seal manufacturer.
 - 4.2. Deliver and place HMA using equipment with pneumatic tires or rubber-faced wheels. Do not operate other vehicles or equipment on the bare deck seal.
 - 4.3. Deposit HMA on the deck seal in such a way that the deck seal is not damaged. Do not use a windrow.

- 4.4. Place HMA in a downhill direction on bridge decks with grades over 2 percent.
- 4.5. Self-propelled spreading equipment is not required.

39-6.04 PAYMENT

Not Used

39-7 MINOR HOT MIX ASPHALT

39-7.01 GENERAL

39-7.01A Summary

Section 39-7 includes specifications for producing and placing minor hot mix asphalt.

Minor HMA must comply with section 39-2 except as specified in this section 39-7.

39-7.01B Definitions

Reserved

39-7.01C Submittals

The QC plan, test results, and inertial profiler specifications in sections 39-1.01C(3), 39-1.01C(4), 39-1.01C(13)(c)–(d) do not apply.

39-7.01D Quality Control and Assurance

39-7.01D(1) General

For minor HMA, the JMF renewal, inertial profiler certifications and testing, and prepaving meeting specifications in sections 39-1.01D(4), 39-1.01D(6)(c), and 39-1.01D(7) do not apply.

Test pavement smoothness with a 12 foot straightedge.

39-7.01D(2) Quality Control

For minor HMA, section 39-2.01D(2) applies except testing for compliance with the following quality characteristics is not required:

1. Flat and elongated particles
2. Fine aggregate angularity
3. Hamburg wheel track
4. Moisture susceptibility

39-7.01D(3) Department Acceptance

The Department accepts minor HMA under section 39-2.01D(5) except compliance with the following quality characteristics is not required:

1. Flat and elongated particles
2. Fine aggregate angularity
3. Hamburg wheel track
4. Moisture susceptibility

39-7.02 MATERIALS

39-7.02A General

Reserved

39-7.02B Mix Design

The mix design for minor HMA must comply with section 39-2.02B except the Hamburg wheel track and moisture susceptibility requirements do not apply.

39-7.02C Asphalt Binder

The grade of asphalt binder for minor HMA must be PG-64-10 or PG-64-16.

39-7.02D Liquid Antistrip Treatment

10-17-14

Treat minor HMA with liquid antistrip. Liquid antistrip treatment is not required if you submit AASHTO T 283 and AASHTO T 324 (Modified) test results showing compliance with section 39-2.02B. The tests must be dated within 12 months of submittal.

04-18-14

39-7.03 CONSTRUCTION

Not Used

39-7.04 PAYMENT

Not Used

39-8-39-10 RESERVED

^^

40 CONCRETE PAVEMENT

07-19-13

Replace the headings and paragraphs in section 40 with:

07-19-13

40-1 GENERAL

40-1.01 GENERAL

40-1.01A Summary

Section 40-1 includes general specifications for constructing concrete pavement.

40-1.01B Definitions

concrete raveling: Progressive disintegration of the pavement surface resulting from dislodged aggregate.

full depth crack: Crack that runs from one edge of the slab to the opposite or adjacent side of the slab, except a crack parallel to and within 0.5 foot of either side of a planned contraction joint

working crack: Crack that extends through the full depth of the slab and is parallel to and within 0.5 foot of either side of a planned contraction joint.

action limit: Value at which corrective actions must be made while production may continue.

suspension limit: Value at which production must be suspended while corrections are made.

40-1.01C Submittals

40-1.01C(1) General

At least 15 days before delivery to the job site, submit manufacturer's recommendations and instructions for storage and installation of:

1. Threaded tie bar splice couplers
2. Joint filler

As an informational submittal, submit calibration documentation and operational guidelines for frequency measuring devices (tachometer) for concrete consolidation vibrators.

Submit updated quality control charts each paving day.

40-1.01C(2) Certificates of Compliance

Submit a certificate of compliance for:

1. Tie bars
2. Threaded tie bar splice couplers
3. Dowel bars
4. Tie bar baskets
5. Dowel bar baskets
6. Joint filler
7. Epoxy powder coating

40-1.01C(3) Quality Control Plan

Submit a concrete pavement QC plan. Allow 30 days for review.

40-1.01C(4) Mix Design

At least 15 days before testing for mix proportions, submit a copy of the AASHTO accreditation for your laboratory determining the mix proportions. At least 15 days before starting field qualification, submit the proposed concrete mix proportions, the corresponding mix identifications, and laboratory test reports including the modulus of rupture for each trial mixture at 10, 21, 28, and 42 days.

40-1.01C(5) Concrete Field Qualification

Submit field qualification data and test reports including:

1. Mixing date
2. Mixing equipment and procedures used
3. Batch volume in cubic yards. The minimum batch size is 5 cu yd.
4. Type and source of ingredients used
5. Penetration of the concrete
6. Air content of the plastic concrete
7. Age and strength at time of concrete beam testing

Field qualification test reports must be certified with a signature by an official in responsible charge of the laboratory performing the tests.

40-1.01C(6) Cores

Submit for authorization the name of the laboratory you propose to use for testing the cores for air content.

Submit each core in an individual plastic bag marked with a location description.

40-1.01C(7) Profile Data and Straightedge Measurements

At least 5 business days before start of initial profiling or changing profiler or operator, submit:

1. Inertial profiler (IP) certification issued by the Department. The certification must not be more than 12 months old.
2. Operator certification for the IP issued by the Department. The operator must be certified for each different model of IP device operated. The certification must not be more than 12 months old.
3. List of manufacturer's recommended test procedures for IP calibration and verification.

Within 2 business days after cross correlation testing, submit ProVAL profiler certification analysis report for cross correlation test results performed on test section. ProVAL is FHWA's software. Submit the certification analysis report to the Engineer and to the electronic mailbox address:

smoothness@dot.ca.gov

Within 2 business days after each day of inertial profiling, submit profile data to the Engineer and to the electronic mailbox address:

smoothness@dot.ca.gov

Within 2 business days of performing straightedge testing, submit a report of areas requiring smoothness correction.

40-1.01C(8)–40-1.01C(12) Reserved

40-1.01D Quality Control and Assurance

40-1.01D(1) General

If the pavement quantity is at least 2000 cu yd, provide a QC manager.

Core pavement as described for, thickness, bar placement, and air content.

For the Department's modulus of rupture testing, assist the Engineer in fabricating test beams by providing materials and labor.

Allow at least 25 days for the Department to schedule testing for coefficient of friction. Notify the Engineer when the pavement is scheduled to be opened to traffic. Notify the Engineer when the pavement is ready for testing which is the latter of:

1. Seven days after paving
2. When the pavement has attained a modulus of rupture of at least 550 psi

The Department tests for coefficient of friction within 7 days of receiving notification that the pavement is ready for testing.

40-1.01D(2) Prepaving Conference

Schedule a prepaving conference at a mutually agreed upon time and place to meet with the Engineer. Make the arrangements for the conference facility. Discuss QC plan and methods of performing each item of the work.

Prepaving conference attendees must sign an attendance sheet provided by the Engineer. The prepaving conference must be attended by your:

1. Project superintendent
2. QC manager
3. Paving construction foreman
4. Workers and your subcontractor's workers, including:
 - 4.1. Foremen including subcontractor's Foremen
 - 4.2. Concrete plant manager
 - 4.3. Concrete plant operator

Do not start paving activities including test strips until the listed personnel have attended a prepaving conference.

40-1.01D(3) Just-In-Time-Training

Reserved

40-1.01D(4) Quality Control Plan

Establish, implement, and maintain a QC plan for pavement. The QC plan must describe the organization and procedures used to:

1. Control the production process
2. Determine if a change to the production process is needed
3. Implement a change

The QC plan must include action and suspension limits and details of corrective action to be taken if any process is out of those limits. Suspension limits must not exceed specified acceptance criteria.

The QC plan must address the elements affecting concrete pavement quality including:

1. Mix proportions
2. Aggregate gradation
3. Materials quality
4. Stockpile management
5. Line and grade control
6. Proportioning
7. Mixing and transportation
8. Placing and consolidation
9. Contraction and construction joints
10. Bar reinforcement placement and alignment

11. Dowel bar placement, alignment, and anchorage
12. Tie bar placement
13. Modulus of rupture
14. Finishing and curing
15. Protecting pavement
16. Surface smoothness

40-1.01D(5) Mix Design

Use a laboratory that complies with ASTM C 1077 to determine the mix proportions for concrete pavement. The laboratory must have a current AASHTO accreditation for:

1. AASHTO T 97 or ASTM C 78
2. ASTM C 192/C 192M

Make trial mixtures no more than 24 months before field qualification.

Using your trial mixtures, determine the minimum cementitious materials content. Use your value for minimum cementitious material content for *MC* in equation 1 and equation 2 of section 90-1.02B(3).

To determine the minimum cementitious materials content or maximum water to cementitious materials ratio, use modulus of rupture values of at least 570 psi for 28 days age and at least 650 psi for 42 days age.

If changing an aggregate supply source or the mix proportions, produce a trial batch and field-qualify the new concrete. The Engineer does not adjust contract time for performing sampling, testing, and qualifying new mix proportions or changing an aggregate supply source.

40-1.01D(6) Quality Control Testing

40-1.01D(6)(a) General

Testing laboratories and testing equipment must comply with the Department's Independent Assurance Program.

40-1.01D(6)(b) Concrete Mix

Before placing pavement, your mix design must be field qualified. Use an ACI certified "Concrete Laboratory Technician, Grade I" to perform field qualification tests and calculations. Test for modulus of rupture under California Test 523 at 10, 21, and 28 days of age.

When placing pavement, your quality control must include testing properties at the frequencies shown in the following table:

QC Testing Frequency

Property	Test method	Minimum frequency
Cleanness value	California Test 227	2 per day
Sand equivalent	California Test 217	2 per day
Aggregate gradation	California Test 202	2 per day
Air content (air entrainment specified)	California Test 504	1 per hour
Air content (air entrainment not specified)	California Test 504	1 per 4 hours
Density	California Test 518	1 per 4 hours
Penetration	California Test 533	1 per 4 hours
Aggregate moisture meter calibration ^a	California Test 223 or California Test 226	1 per day

^a Check calibration of the plant moisture meter by comparing moisture meter readings with California Test 223 or California Test 226 test results.

Maintain control charts to identify potential problems and assignable causes. Post a copy of each control chart at a location determined by the Engineer.

Individual measurement control charts must use the target values in the mix proportions as indicators of central tendency.

Develop linear control charts for:

1. Cleanness value
2. Sand equivalent
3. Fine and coarse aggregate gradation
4. Air content
5. Penetration

Control charts must include:

1. Contract number
2. Mix proportions
3. Test number
4. Each test parameter
5. Action and suspension limits
6. Specification limits
7. Quality control test results

For fine and coarse aggregate gradation control charts, record the running average of the previous 4 consecutive gradation tests for each sieve and superimpose the specification limits.

For air content control charts, the action limit is ± 1.0 percent of the specified value. If no value is specified, the action limit is ± 1.0 percent of the value used for your approved mix design.

As a minimum, a process is out of control if any of the following occurs:

1. For fine and coarse aggregate gradation, 2 consecutive running averages of 4 tests are outside the specification limits
2. For individual penetration or air content measurements:
 - 2.1. One point falls outside the suspension limit line
 - 2.2. Two points in a row fall outside the action limit line

Stop production and take corrective action for out of control processes or the Engineer rejects subsequent material.

Before each day's concrete pavement placement and at intervals not to exceed 4 hours of production, use a tachometer to test and record vibration frequency for concrete consolidation vibrators.

40-1.01D(6)(c) Pavement Smoothness

40-1.01D(6)(c)(i) General

Notify the Engineer 2 business days before performing smoothness testing including IP calibration and verification testing. The notification must include start time and locations by station.

Before testing the pavement smoothness, remove foreign objects from the surface, and mark the beginning and ending station on the pavement shoulder.

Test pavement smoothness using an IP except use a 12-foot straightedge at the following locations:

1. Traffic lanes less than 1,000 feet in length including ramps, turn lanes, and acceleration and deceleration lanes
2. Areas within 15 feet of manholes
3. Shoulders
4. Weigh-in-motion areas
5. Miscellaneous areas such as medians, gore areas, turnouts, and maintenance pullouts

40-1.01D(6)(c)(ii) Straightedge Testing

Identify locations of areas requiring correction by:

1. Location Number
2. District-County-Route
3. Beginning station or post mile to the nearest 0.01 mile
4. For correction areas within a lane:
 - 4.1. Lane direction as NB, SB, EB, or WB
 - 4.2. Lane number from left to right in direction of travel
 - 4.3. Wheel path as "L" for left, "R" for right, or "B" for both
5. For correction areas not within a lane:
 - 5.1. Identify pavement area (e.g., shoulder, weight station, turnout)
 - 5.2. Direction and distance from centerline as "L" for left or "R" for right

6. Estimated size of correction area

40-1.01D(6)(c)(iii) Inertial Profile Testing

IP equipment must display a current certification decal with expiration date.

Conduct cross correlation IP verification test in the Engineer's presence before performing initial profiling. Verify cross correlation IP verification test at least annually. Conduct 5 repeat runs of the IP on an authorized test section. The test section must be on an existing concrete pavement surface 0.1 mile long. Calculate a cross correlation to determine the repeatability of your device under Section 8.3.1.2 of AASHTO R 56 using ProVAL profiler certification analysis with a 3 feet maximum offset. The cross correlation must be a minimum of 0.92.

Conduct the following IP calibration and verification tests in the Engineer's presence each day before performing inertial profiling:

1. Block test. Verify the height sensor accuracy under AASHTO R 57, section 5.3.2.3.
2. Bounce test. Verify the combined height sensor and accelerometer accuracy under AASHTO R 57, section 5.3.2.3.2.
3. DMI test. Calibrate the accuracy of the testing procedure under AASHTO R 56, section 8.4.
4. Manufacturer's recommended tests.

Collect IP data using the specified ProVAL analysis with 250 mm and IRI filters. Comply with the requirements for data collection under AASHTO R 56.

For IP testing, wheel paths are 3 feet from and parallel to the edge of a lane. Left and right are relative to the direction of travel. The IRI is the pavement smoothness along a wheel path of a given lane. The MRI is the average of the IRI values for the left and right wheel path from the same lane.

Operate the IP according to the manufacturer's recommendations and AASHTO R 57 at 1-inch recording intervals and a minimum 4 inch line laser sensor.

Collect IP data under AASHTO R 56. IP data must include:

1. Raw profile data for each lane.
2. ProVAL ride quality analysis report for the international roughness index (IRI) of left and right wheel paths of each lane. Submit in pdf file format.
3. ProVAL ride quality analysis report for the mean roughness index (MRI) of each lane. Submit in pdf file format.
4. ProVAL smoothness assurance analysis report for IRIs of left wheel path. Submit in pdf file format.
5. ProVAL smoothness assurance analysis report for IRIs of right wheel path. Submit in pdf file format.
6. GPS data file for each lane in GPS exchange. Submit in GPS eXchange file format.
7. Manufacturer's recommended IP calibration and verification tests results.
8. AASHTO IP calibration and verification test results including bounce, block, and distance measurement instrument (DMI).

Submit the IP raw profile data in unfiltered electronic pavement profile file (PPF) format. Name the PPF file using the following naming convention:

YYYYMMDD_TTCCRRR_D_L_W_S_X_PT.PPF

where:

YYYY = year

MM = Month, leading zero

DD = Day of month, leading zero

TT = District, leading zero

CCC = County, 2 or 3 letter abbreviation as shown in section 1-1.08

RRR = Route number, no leading zeros

D = Traffic direction as NB, SB, WB, or EB

L = Lane number from left to right in direction of travel

W = Wheel path as "L" for left, "R" for right, or "B" for both

S = Beginning station to the nearest foot (e.g., 10+20) or beginning post mile to the nearest hundredth (e.g., 25.06) no leading zero

X = Profile operation as "EXIST" for existing pavement, "PAVE" for after paving, or "CORR" for after final surface pavement correction

PT = Pavement type (e.g., "concrete", etc.)

Determine IRIs using the ProVAL ride quality analysis with a 250 mm and IRI filters. While collecting the profile data to determine IRI, record the following locations in the raw profile data:

1. Begin and end of all bridge approach slabs
2. Begin and end of all bridges
3. Begin and end of all culverts visible on the roadway surface

For each 0.1 mile section, your IRI values must be within 10 percent of the Department's IRI values. The Engineer may order you to recalibrate your IP equipment and reprofile. If your results are inaccurate due to operator error, the Engineer may disqualify your IP operator.

Determine the MRI for 0.1-mile fixed sections. A partial section less than 0.1 mile that is the result of an interruption to continuous pavement surface must comply with the MRI specifications for a full section. Adjust the MRI for a partial section to reflect a full section based on the proportion of a section paved.

Determine the areas of localized roughness. Use the ProVAL smoothness assurance with a continuous IRI for each wheel path, 25-foot interval, and 250 mm and IRI filters.

40-1.01D(6)(c)(iv) Reserved

40-1.01D(6)(d)–40-1.01D(6)(h) Reserved

40-1.01D(7) Pavement Acceptance

40-1.01D(7)(a) Acceptance Testing

40-1.01D(7)(a)(i) General

The Department's acceptance testing includes testing the pavement properties at the minimum frequencies shown in the following table:

Acceptance Testing

Property	Test Method		Frequency ^a
	CRCP	JPCP	
Modulus of rupture (28 day)	California Test 523		1,000 cu yd
Air content ^b	California Test 504		1 day's paving
Dowel bar placement	--	Measurement ^a	700 sq yd
Tie bar placement	--	Measurement ^a	4,000 sq yd
Thickness	California Test 531		1,200 sq yd
Coefficient of friction	California Test 342		1 day's paving

^aA single test represents no more than the frequency specified.

^bTested only when air entrainment is specified.

Pavement smoothness may be accepted based on your testing in the absence of the Department's testing.

40-1.01D(7)(a)(ii) Air Content

If air-entraining admixtures are specified, the Engineer uses a t-test to compare your QC test results with the Department's test results. The t-value for test data is determined using the following equation:

$$t = \frac{|\bar{X}_c - \bar{X}_v|}{S_p \sqrt{\frac{1}{n_c} + \frac{1}{n_v}}} \quad \text{and} \quad S_p^2 = \frac{S_c^2(n_c - 1) + S_v^2(n_v - 1)}{n_c + n_v - 2}$$

where:

- n_c = Number of your quality control tests (minimum of 6 required)
- n_v = Number of Department's tests (minimum of 2 required)
- \bar{X}_c = Mean of your quality control tests
- \bar{X}_v = Mean of the Department's tests
- S_p = Pooled standard deviation
(When $n_v = 1$, $S_p = S_c$)
- S_c = Standard deviation of your quality control tests
- S_v = Standard deviation of the Department's tests (when $n_v > 1$)

The Engineer compares your QC test results with the Department's test results at a level of significance of $\alpha = 0.01$. The Engineer compares the t-value to t_{crit} , using degrees of freedom showing in the following table:

degrees of freedom (nc+nv-2)	tcrit (for $\alpha = 0.01$)
1	63.657
2	9.925
3	5.841
4	4.604
5	4.032
6	3.707
7	3.499
8	3.355
9	3.250
10	3.169

If the t-value calculated is less than or equal to tcrit, your quality control test results are verified. If the t-value calculated is greater than tcrit, quality control test results are not verified.

If your quality control test results are not verified, core at least 3 specimens from concrete pavement under section 40-1.03P. The Engineer selects the core locations. The authorized laboratory must test these specimens for air content under ASTM C 457. The Engineer compares these test results with your quality control test results using the t-test method. If your quality control test results are verified based on this comparison, the Engineer uses the quality control test results for acceptance of concrete pavement for air content. If your quality control test results are not verified based on this comparison, the Engineer uses the air content of core specimens determined by the authorized laboratory under ASTM C 457 for acceptance.

40-1.01D(7)(a)(iii) Dowel and Tie Bar Placement

For JPCP, drill cores under section 40-1.03P for the Department's acceptance testing.

The Engineer identifies which joint and dowel or tie bar are to be tested. Core each day's paving within 2 business days. Each dowel or tie bar test consists of 2 cores, 1 on each bar end to expose both ends and allow measurement.

If the tests indicate dowel or tie bars are not placed within the specified tolerances or if there is unconsolidated concrete around the dowel or tie bars, core additional specimens identified by Engineer to determine the limits of unacceptable work.

40-1.01D(7)(a)(iv) Thickness

Drill cores under section 40-1.03P for the Department's acceptance testing in the primary area, which is the area placed in 1 day for each thickness. Core at locations determined by the Engineer and in the Engineer's presence.

Do not core until any grinding has been completed.

The core specimen diameter must be 4 inches. To identify the limits of concrete pavement deficient in thickness by more than 0.05 foot, you may divide primary areas into secondary areas. The Engineer measures cores under California Test 531 to the nearest 0.01 foot. Core at least 1 foot from existing, contiguous, and parallel concrete pavement not constructed as part of this Contract.

You may request the Engineer make additional thickness measurements and use them to determine the average thickness variation. The Engineer determines the locations with random sampling methods.

If each thickness measurement in a primary area is less than 0.05 foot deficient, the Engineer calculates the average thickness deficiency in that primary area. The Engineer uses 0.02 foot for a thickness difference more than 0.02 foot over the specified thickness.

For each thickness measurement in a primary area deficient by more than 0.05 foot, the Engineer determines a secondary area where the thickness deficiency is more than 0.05 foot. The Engineer determines this secondary area by measuring the thickness of each concrete pavement slab adjacent to the measurement found to be more than 0.05 foot deficient. The Engineer continues to measure the thickness until an area that is bound by slabs with thickness deficient by 0.05 foot or less is determined.

Slabs without bar reinforcement are defined by the areas bound by longitudinal and transverse joints and concrete pavement edges. Slabs with bar reinforcement are defined by the areas bound by longitudinal joints and concrete pavement edges and 15-foot lengths. Secondary area thickness measurements in a slab determine that entire slab's thickness.

The Engineer measures the remaining primary area thickness after removing the secondary areas from consideration for determining the average thickness deficiency.

40-1.01D(7)(a)(v)–40-1.01D(7)(a)(ix) Reserved

40-1.01D(7)(b) Acceptance Criteria

40-1.01D(7)(b)(i) General

Reserved

40-1.01D(7)(b)(ii) Modulus of Rupture

For field qualification, the modulus of rupture at no later than 28 days must be at least:

1. 550 psi for each single beam
2. 570 psi for the average of 5 beams

For production, the modulus of rupture for the average of the individual test results of 2 beams aged for 28 days must be at least 570 psi.

40-1.01D(7)(b)(iii) Air Content

The air content must be within ± 1.5 percent of the specified value. If no value is specified, the air content must be within ± 1.5 percent of, the value used for your approved mix design.

40-1.01D(7)(b)(iv) Bar Reinforcement

In addition to requirements of Section 52, bar reinforcement must be more than 1/2 inch below the saw cut depth at concrete pavement joints.

40-1.01D(7)(b)(v) Dowel Bar and Tie Bar Placement

Tie bar placement must comply with the tolerances shown in the following table:

Tie Bar Tolerance

Dimension	Tolerance
Horizontal and vertical skew	5 1/4 inch, max
Longitudinal translation	± 2 inch
Horizontal offset (embedment)	± 2 inch
Vertical depth	1. At least 1/2 inch below the bottom of the saw cut 2. When measured at any point along the bar, not less than 2 inches clear of the pavement's surface and bottom

NOTE: Tolerances are measured relative to the completed joint.

Dowel bar placement must comply with the tolerances shown in the following table:

Dowel Bar Tolerances

Dimension	Tolerance
Horizontal offset	±1 inch
Longitudinal translation	±2 inch
Horizontal skew	5/8 inch, max
Vertical skew	5/8 inch, max
Vertical depth	The minimum distance measured from concrete pavement surface to any point along the top of dowel bar must be: $DB + 1/2 \text{ inch}$ where: DB = one third of pavement thickness in inches, or the saw cut depth, whichever is greater The maximum distance below the depth shown must be 5/8 inch.

NOTE: Tolerances are measured relative to the completed joint.

The Engineer determines the limits for removal and replacement.

40-1.01D(7)(b)(vi) Pavement Thickness

Concrete pavement thickness must not be deficient by more than 0.05 foot.

The minimum thickness is not reduced for specifications that may affect concrete pavement thickness such as allowable tolerances for subgrade construction.

The Engineer determines the areas of noncompliant pavement, the thickness deficiencies, and the limits where removal is required.

Pavement with an average thickness deficiency less than 0.01 foot is acceptable. If the thickness deficiency is 0.01 foot or more and less than 0.05 foot, you may request authorization to leave the pavement in place and accept a pay adjustment. If the deficiency is more than 0.05 foot the pavement must be removed and replaced.

40-1.01D(7)(b)(vii) Pavement Smoothness

Where testing with an IP is required, the pavement surface must have:

1. No areas of localized roughness with an IRI greater than 120 in/mi
2. MRI of 60 in/mi or less within a 0.1 mile section

Where testing with a straightedge is required, the pavement surface must not vary from the lower edge of the straightedge by more than:

1. 0.01 foot when the straightedge is laid parallel with the centerline
2. 0.02 foot when the straightedge is laid perpendicular to the centerline and extends from edge to edge of a traffic lane
3. 0.02 foot when the straightedge is laid within 24 feet of a pavement conform

40-1.01D(7)(b)(viii) Coefficient of Friction

Initial and final texturing must produce a coefficient of friction of at least 0.30. Do not open the pavement to traffic unless the coefficient of friction is at least 0.30.

40-1.01D(7)(b)(ix)–40-1.01D(7)(b)(xii) Reserved

40-1.02 MATERIALS

40-1.02A General

Water for coring must comply with section 90.

Tack coat must comply with section 39.

40-1.02B Concrete

40-1.02B(1) General

PCC for pavement must comply with section 90-1 except as otherwise specified.

40-1.02B(2) Cementitious Material

Concrete must contain from 505 pounds to 675 pounds cementitious material per cubic yard. The specifications for reducing cementitious material content in section 90-1.02E(2) do not apply .

40-1.02B(3) Aggregate

Aggregate must comply with section 90-1.02C except the specifications for reduction in operating range and contract compliance for cleanness value and sand equivalent specified in section 90-1.02C(2) and section 90-1.02C(3) do not apply.

For coarse aggregate in high desert and high mountain climate regions, the loss must not exceed 25 percent when tested under California Test 211 with 500 revolutions.

For combined aggregate gradings, the difference between the percent passing the 3/8-inch sieve and the percent passing the no. 8 sieve must not be less than 16 percent of the total aggregate.

40-1.02B(4) Air Entrainment

The second paragraph of section 90-1.02I(2)(a) does not apply.

For a project shown in the low and south mountain climate regions, add air-entraining admixture to the concrete at the rate required to produce an air content of 4 percent in the freshly mixed concrete.

For a project shown in the high desert and high mountain climate regions, add air-entraining admixture to the concrete at the rate required to produce an air content of 6 percent in the freshly mixed concrete.

40-1.02B(5)–40-1.02B(8) Reserved

40-1.02C Reinforcement, Bars, and Baskets

40-1.02C(1) Bar Reinforcement

Bar reinforcement must be deformed bars.

If the project is not shown to be in high desert or any mountain climate region, bar reinforcement must comply with section 52.

If the project is shown to be in high desert or any mountain climate regions, bar reinforcement must be one of the following:

1. Epoxy-coated bar reinforcement under section 52-2.03B except bars must comply with either ASTM A 706/A 706M; ASTM A 996/A 996M; or ASTM A 615/A 615M, Grade 40 or 60. Bars must be handled under ASTM D 3963/D 3963M and section 52-2.02C.
2. Low carbon, chromium steel bar complying with ASTM A 1035/A 1035M

40-1.02C(2) Dowel Bars

Dowel bars must be plain bars. Fabricate, sample, and handle epoxy-coated dowel bars under ASTM D 3963/D 3963M and section 52-2.03C except each sample must be 18 inches long.

If the project is not shown to be in high desert or any mountain climate region, dowel bars must be one of the following:

1. Epoxy-coated bars. Bars must comply with ASTM A 615/A 615M, Grade 40 or 60. Epoxy coating must comply with either section 52-2.02B or 52-2.03B.
2. Stainless-steel bars. Bars must be descaled solid stainless-steel bars under ASTM A 955/A 955M, UNS Designation S31603 or S31803.
3. Low carbon, chromium-steel bars under ASTM A 1035/A 1035M.

If the project is shown to be in high desert or any mountain climate region, dowel bars must be one of the following:

1. Epoxy-coated bars. Bars must comply with ASTM A 615/A 615M, Grade 40 or 60. Epoxy coating must comply with section 52-2.03B.
2. Stainless-steel bars. Bars must be descaled solid stainless-steel bars under ASTM A 955/A 955M, UNS Designation S31603 or S31803.

40-1.02C(3) Tie Bars

Tie bars must be deformed bars.

If the project is not shown to be in high desert or any mountain climate region, tie bars must be one of the following:

1. Epoxy-coated bar reinforcement. Bars must comply with either section 52-2.02B or 52-2.03B except bars must comply with either ASTM A 706/A 706M; ASTM A 996/A 996M; or ASTM A 615/A 615M, Grade 40 or 60.
2. Stainless-steel bars. Bars must be descaled solid stainless-steel bars under ASTM A 955/A 955M, UNS Designation S31603 or S31803.
3. Low carbon, chromium-steel bars under ASTM A 1035/A 1035M.

If the project is shown to be in high desert or any mountain climate region, tie bars must be one of the following:

1. Epoxy-coated bar reinforcement. Bars must comply with section 52-2.03B except bars must comply with either ASTM A 706/A 706M; ASTM A 996/A 996M; or ASTM A 615/A 615M, Grade 40 or 60.
2. Stainless-steel bars. Bars must be descaled solid stainless-steel bars under ASTM A 955/A 955M, UNS Designation S31603 or S31803.

Fabricate, sample, and handle epoxy-coated tie bars under ASTM D 3963/D 3963M, section 52-2.02, or section 52-2.03.

Do not bend tie bars.

40-1.02C(4) Dowel and Tie Bar Baskets

For dowel and tie bar baskets, wire must comply with ASTM A 82/A 82M and be welded under ASTM A 185/A 185M, Section 7.4. The minimum wire-size no. is W10. Use either U-frame or A-frame shaped assemblies.

If the project is not shown to be in high desert or any mountain climate region, baskets may be epoxy-coated, and the epoxy coating must comply with either section 52-2.02B or 52-2.03B.

If the project is shown to be in high desert or any mountain climate region, wire for dowel bar and tie bar baskets must be one of the following:

1. Epoxy-coated wire complying with section 52-2.03B
2. Stainless-steel wire. Wire must be descaled solid stainless-steel. Wire must comply with (1) the chemical requirements in ASTM A 276/A 276M, UNS Designation S31603 or S31803 and (2) the tension requirements in ASTM A 1022/ A 1022M.

Handle epoxy-coated tie bar and dowel bar baskets under ASTM D 3963/D 3963M and either section 52-2.02 or 52-2.03.

Fasteners must be driven fasteners under ASTM F 1667. Fasteners on lean concrete base or HMA must have a minimum shank diameter of 3/16 inch and a minimum shank length of 2-1/2 inches. For asphalt treated permeable base or cement treated permeable base, the shank diameter must be at least 3/16 inch and the shank length must be at least 5 inches.

Fasteners, clips, and washers must have a minimum 0.2-mil thick zinc coating applied by either electroplating or galvanizing.

40-1.02D Dowel Bar Lubricant

Dowel bar lubricant must be petroleum paraffin based or a curing compound. Paraffin-based lubricant must be Dayton Superior DSC BB-Coat or Valvoline Tectyl 506 or an approved equal and must be factory-applied. Curing compound must be curing compound no. 3.

40-1.02E Joint Filler

Joint filler for isolation joint must be preformed expansion joint filler for concrete (bituminous type) under ASTM D 994.

40-1.02F Curing Compound

Curing compound must be curing compound no. 1 or 2.

40-1.02G Nonshrink Hydraulic Cement Grout

Nonshrink hydraulic cement grout must comply with ASTM C 1107/C 1107M. Clean, uniform, rounded aggregate filler may be used to extend the grout. Aggregate filler must not exceed 60 percent of the grout mass or the maximum recommended by the manufacturer, whichever is less. Aggregate filler moisture content must not exceed 0.5 percent when tested under California Test 223 or California Test 226. Aggregate filler tested under California Test 202 must comply with the grading shown in the following table:

Aggregate Filler Grading	
Sieve size	Percentage passing
1/2-inch	100
3/8-inch	85–100
No. 4	10–30
No. 8	0–10
No. 16	0–5

40-1.02H Temporary Roadway Pavement Structure

Temporary roadway pavement structure must comply with section 41-1.02E.

40-1.02I–40-1.02N Reserved

40-1.03 CONSTRUCTION

40-1.03A General

Aggregate and bulk cementitious material must be proportioned by weight by means of automatic proportioning devices of approved types.

For widenings and lane reconstruction, construct only the portion of pavement where the work will be completed during the same lane closure. If you fail to complete the construction during the same lane closure, construct a temporary pavement structure under section 41-1.

40-1.03B Water Supply

Before placing concrete pavement, develop enough water supply.

40-1.03C Test Strips

Construct a test strip for each type of pavement with a quantity of more than 2,000 cu yd. Obtain authorization of the test strip before constructing pavement. Test strips must be:

1. 700 to 1,000 feet long
2. Same width as the planned paving, and
3. Constructed using the same equipment proposed for paving

The Engineer selects from 6 to 12 core locations for dowel bars and up to 6 locations for tie bars per test strip. If you use mechanical dowel bar inserters, the test strip must demonstrate they do not leave voids, segregations, or surface irregularities such as depressions, dips, or high areas.

Test strips must comply with the acceptance criteria for:

1. Smoothness, except IP is not required
2. Dowel bars and tie bars placement
3. Pavement thickness
4. Final finishing, except the coefficient of friction is not considered

Allow 3 business days for evaluation. If the test strip is noncompliant, stop paving and submit a plan for changed materials, methods, or equipment. Allow 3 business days for authorization of the plan. Construct another test strip per the authorized plan.

Remove and dispose of noncompliant test strips.

If the test strip is compliant except for smoothness and final finishing, you may grind the surface. After grinding retest the test strip smoothness under section 40-1.01D(6)(c).

If the test strip is compliant for smoothness and thickness, construction of an additional test strip is not required and the test strip may remain in place.

Construct additional test strips if you:

1. Propose different paving equipment including:
 - 1.1. Paver
 - 1.2. Dowel bar inserter
 - 1.3. Tie bar inserter
 - 1.4. Tining
 - 1.5. Curing equipment
2. Change concrete mix proportions

You may request authorization to eliminate the test strip if you use paving equipment and personnel from a Department project (1) for the same type of pavement and (2) completed within the past 12 months. Submit supporting documents and previous project information with your request.

40-1.03D Joints

40-1.03D(1) General

Do not bend tie bars or reinforcement in existing concrete pavement joints.

For contraction joints and isolation joints, saw cut a groove with a power-driven saw. After cutting, immediately wash slurry from the joint with water at less than 100 psi pressure.

Keep joints free from foreign material including soil, gravel, concrete, and asphalt. To keep foreign material out of the joint, you may use filler material. Filler material must not react adversely with the concrete or cause concrete pavement damage. After sawing and washing, install filler material that keeps moisture in the adjacent concrete during the 72 hours after paving. If you install filler material, the specifications for spraying the sawed joint with additional curing compound in section 40-1.03K does not apply. If using absorptive filler material, moisten the filler immediately before or after installation.

40-1.03D(2) Construction Joints

Construction joints must be vertical.

Before placing fresh concrete against hardened concrete, existing concrete pavement, or structures, apply curing compound no. 1 or 2 to the vertical surface of the hardened concrete, existing concrete pavement, or structures and allow it to dry.

At joints between concrete pavement and HMA, apply tack coat between the concrete pavement and HMA.

Use a metal or wooden bulkhead to form transverse construction joints. If dowel bars are described, the bulkhead must allow dowel bar installation.

40-1.03D(3) Contraction Joints

Saw contraction joints before cracking occurs and after the concrete is hard enough to saw without spalling, raveling, or tearing.

Saw cut using a power saw with a diamond blade. After cutting, immediately wash slurry from the joint with water at less than 100 psi pressure.

Except for longitudinal joints parallel to a curving centerline, transverse and longitudinal contraction joints must not deviate by more than 0.1 foot from either side of a 12-foot straight line

Cut transverse contraction joints within 0.5 foot of the spacing described. Adjust spacing if needed such that slabs are at least 10 feet long.

For widenings, do not match transverse contraction joints with existing joint spacing or skew unless otherwise described.

Cut transverse contraction joints straight across the full concrete pavement width, between isolation joints and edges of pavement. In areas of converging and diverging pavements, space transverse contraction joints such that the joint is continuous across the maximum pavement width. Longitudinal contraction joints must be parallel with the concrete pavement centerline, except when lanes converge or diverge.

40-1.03D(4) Isolation Joints

Before placing concrete at isolation joints, prepare the existing concrete face and secure joint filler. Prepare by saw cutting and making a clean flat vertical surface. Make the saw cut the same depth as the depth of the new pavement.

40-1.03E Bar Reinforcement

Place bar reinforcement under section 52.

40-1.03F Dowel Bar Placement

If using curing compound as lubricant, apply the curing compound to dowels in 2 separate applications. Lubricate each dowel bar entirely before placement. The last application must be applied not more than 8 hours before placing the dowel bars. Apply each curing compound application at a rate of 1 gallon per 150 square feet.

Install dowel bars using one of the following methods:

1. Drill and bond bars. Comply with section 41-10.
2. Mechanical insertion. Eliminate evidence of the insertion by reworking the concrete over the dowel bars.
3. Dowel bar baskets. Anchor baskets with fasteners. Use at least 1 fastener per foot for basket sections. Baskets must be anchored at least 200 feet in advance of the concrete placement activity unless your waiver request is authorized. If requesting a waiver, describe the construction limitations or restricted access preventing the advanced anchoring. After the baskets are anchored and before

the concrete is placed, cut and remove temporary spacer wires and demonstrate the dowel bars do not move from their specified depth and alignment during concrete placement.

If dowel bars are noncompliant, stop paving activities, demonstrate your correction, and obtain verbal approval from the Engineer.

40-1.03G Tie Bar Placement

Install tie bars at longitudinal joints using one of the following methods:

1. Drill and bond bars. Comply with section 41-10.
2. Insert bars. Mechanically insert tie bars into plastic slip-formed concrete before finishing. Inserted tie bars must have full contact between the bar and the concrete. Eliminate evidence of the insertion by reworking the concrete over the tie bars.
3. Threaded couplers. Threaded tie bar splice couplers must be fabricated from deformed bar reinforcement and free of external welding or machining.
4. Tie bar baskets. Anchor baskets at least 200 feet in advance of pavement placement activity. If you request a waiver, describe the construction limitations or restricted access preventing the advanced anchoring. After the baskets are anchored and before paving, demonstrate the tie bars do not move from their specified depth and alignment during paving. Use fasteners to anchor tie bar baskets.

If tie bars are noncompliant, stop paving activities, demonstrate your correction, and obtain verbal approval from the Engineer.

40-1.03H Placing Concrete

40-1.03H(1) General

Immediately prior to placing concrete, the surface to receive concrete must be:

1. In compliance with specified requirements, including compaction and elevation tolerances
2. Free of loose and extraneous material
3. Uniformly moist, but free of standing or flowing water

Place concrete pavement with stationary side forms or slip-form paving equipment.

Place consecutive concrete loads within 30 minutes of each other. Construct a transverse construction joint when concrete placement is interrupted by more than 30 minutes. The transverse construction joint must coincide with the next contraction joint location, or you must remove fresh concrete pavement to the preceding transverse joint location.

Place concrete pavement in full slab widths separated by construction joints or monolithically in multiples of full lane widths with a longitudinal contraction joint at each traffic lane line.

Do not retemper concrete.

If the concrete pavement surface width is constructed as specified, you may construct concrete pavement sides on a batter not flatter than 6:1 (vertical:horizontal).

40-1.03H(2) Paving Adjacent to Existing Concrete Pavement

Where pavement is placed adjacent to existing concrete pavement:

1. Grinding adjacent pavement must be completed before placing the pavement

2. Use paving equipment with padded crawler tracks or rubber-tired wheels with enough offset to prevent damage
3. Match pavement grade with the elevation of existing concrete pavement after grinding.

40-1.03H(3) Concrete Pavement Transition Panel

For concrete pavement placed in a transition panel, texture the surface with a drag strip of burlap, broom, or spring steel tine device that produces scoring in the finished surface. Scoring must be either parallel or transverse to the centerline. Texture at the time that produces the coarsest texture.

40-1.03H(4) Stationary Side Form Construction

Stationary side forms must be straight and without defects including warps, bends, and indentations. Side forms must be metal except at end closures and transverse construction joints where other materials may be used.

You may build up side forms by attaching a section to the top or bottom. If attached to the top of metal forms, the attached section must be metal.

The side form's base width must be at least 80 percent of the specified concrete pavement thickness.

Side forms including interlocking connections with adjoining forms must be rigid enough to prevent springing from subgrading and paving equipment and concrete pressure.

Construct subgrade to final grade before placing side forms. Side forms must bear fully on the foundation throughout their length and base width. Place side forms to the specified grade and alignment of the finished concrete pavement's edge. Support side forms during concrete placing, compacting, and finishing.

After subgrade work is complete and immediately before placing concrete, true side forms and set to line and grade for a distance that avoids delays due to form adjustment.

Clean and oil side forms before each use.

Side forms must remain in place for at least 1 day after placing concrete and until the concrete pavement edge no longer requires protection from the forms.

Spread, screed, shape, and consolidate concrete with 1 or more machines. The machines must uniformly distribute and consolidate the concrete. The machines must operate to place the concrete pavement to the specified cross section with minimal hand work.

Consolidate the concrete without segregation. If vibrators are used:

1. The vibration rate must be at least 3,500 cycles per minute for surface vibrators and 5,000 cycles per minute for internal vibrators
2. Amplitude of vibration must cause perceptible concrete surface movement at least 1 foot from the vibrating element
3. Use a calibrated tachometer for measuring frequency of vibration
4. Vibrators must not rest on side forms or new concrete pavement
5. Power to vibrators must automatically cease when forward or backward motion of the paving machine is stopped
6. Uniformly consolidate the concrete across the paving width including adjacent to forms by using high-frequency internal vibrators within 15 minutes of depositing concrete on the subgrade
7. Do not shift the mass of concrete with vibrators.

40-1.03H(5) Slip-Form Construction

If slip-form construction is used, spread, screed, shape, and consolidate concrete to the specified cross section with slip-form machines and minimal hand work. Slip-form paving machines must be equipped with traveling side forms and must not segregate the concrete.

Do not deviate from the specified concrete pavement alignment by more than 0.1 foot.

Slip-form paving machines must use high frequency internal vibrators to consolidate concrete. You may mount vibrators with their axes parallel or normal to the concrete pavement alignment. If mounted with axes parallel to the concrete pavement alignment, space vibrators no more than 2.5 feet measured center to center. If mounted with axes normal to the concrete pavement alignment, space the vibrators with a maximum 0.5-foot lateral clearance between individual vibrators.

Each vibrator must have a vibration rate from 5,000 to 8,000 cycles per minute. The amplitude of vibration must cause perceptible concrete surface movement at least 1 foot from the vibrating element. Use a calibrated tachometer to measure frequency of vibration.

40-1.03I Edge Treatment

Construct edge treatments as shown. Regrade when required for the preparation of safety edge areas.

Sections 40-1.03J(2) and 40-1.03J(3) do not apply to safety edges.

For safety edges placed after the concrete pavement is complete, concrete may comply with the requirements for minor concrete.

For safety edges placed after the concrete pavement is complete, install connecting bar reinforcement under section 52.

Saw cutting or grinding may be used to construct safety edges.

For safety edges, the angle of the slope must not deviate by more than ± 5 degrees from the angle shown. Measure the angle from the plane of the adjacent finished pavement surface.

40-1.03J Finishing

40-1.03J(1) General

Reserved

40-1.03J(2) Preliminary Finishing

40-1.03J(2)(a) General

Preliminary finishing must produce a smooth and true-to-grade finish. After preliminary finishing, mark each day's paving with a stamp. The stamp must be authorized before paving starts. The stamp must be approximately 1 by 2 feet in size. The stamp must form a uniform mark from 1/8 to 1/4 inch deep. Locate the mark 20 ± 5 feet from the transverse construction joint formed at each day's start of paving and 1 ± 0.25 foot from the pavement's outside edge. The stamp mark must show the month, day, and year of placement and the station of the transverse construction joint. Orient the stamp mark so it can be read from the pavement's outside edge.

Do not apply water to the pavement surface before float finishing.

40-1.03J(2)(b) Stationary Side Form Finishing

If stationary side form construction is used, give the pavement a preliminary finish by the machine float method or the hand method.

If using the machine float method:

1. Use self-propelled machine floats.

2. Determine the number of machine floats required to perform the work at a rate equal to the pavement delivery rate. If the time from paving to machine float finishing exceeds 30 minutes, stop pavement delivery. When machine floats are in proper position, you may resume pavement delivery and paving.
3. Run machine floats on side forms or adjacent pavement lanes. If running on adjacent pavement, protect the adjacent pavement surface under section 40-1.03L. Floats must be hardwood, steel, or steel-shod wood. Floats must be equipped with devices that adjust the underside to a true flat surface.

If using the hand method, finish pavement smooth and true to grade with manually operated floats or powered finishing machines.

40-1.03J(2)(c) Slip-Form Finishing

If slip-form construction is used, the slip-form paver must give the pavement a preliminary finish. You may supplement the slip-form paver with machine floats.

Before the pavement hardens, correct pavement edge slump in excess of 0.02 foot exclusive of edge rounding.

40-1.03J(3) Final Finishing

After completing preliminary finishing, round the edges of the initial paving widths to a 0.04-foot radius. Round transverse and longitudinal construction joints to a 0.02-foot radius.

Before curing, texture the pavement. Perform initial texturing with a burlap drag or broom device that produces striations parallel to the centerline. Perform final texturing with a steel-tined device that produces grooves parallel with the centerline.

Construct longitudinal grooves with a self-propelled machine designed specifically for grooving and texturing pavement. The machine must have tracks to maintain constant speed, provide traction, and maintain accurate tracking along the pavement surface. The machine must have a single row of rectangular spring steel tines. The tines must be from 3/32 to 1/8 inch wide, on 3/4-inch centers, and must have enough length, thickness, and resilience to form grooves approximately 3/16 inch deep. The machine must have horizontal and vertical controls. The machine must apply constant down pressure on the pavement surface during texturing. The machines must not cause raveling.

Construct grooves over the entire pavement width in a single pass except do not construct grooves 3 inches from the pavement edges and longitudinal joints. Final texture must be uniform and smooth. Use a guide to properly align the grooves. Grooves must be parallel and aligned to the pavement edge across the pavement width. Grooves must be from 1/8 to 3/16 inch deep after the pavement has hardened.

For irregular areas and areas inaccessible to the grooving machine, you may hand-construct grooves using the hand method. Hand-constructed grooves must comply with the specifications for machine-constructed grooves.

For ramp termini, use heavy brooming normal to the ramp centerline to produce a coefficient of friction of at least 0.35 determined on the hardened surface under California Test 342.

40-1.03K Curing

Cure the concrete pavement's exposed area under section 90-1.03B using the waterproof membrane method or curing compound method. If using the curing compound method use curing compound no. 1 or 2. When side forms are removed within 72 hours of the start of curing, also cure the concrete pavement edges.

Apply curing compound with mechanical sprayers. Reapply curing compound to saw cuts and disturbed areas.

40-1.03L Protecting Concrete Pavement

Protect concrete pavement under section 90-1.03C.

Maintain the concrete pavement surface temperature at not less than 40 degrees F for the initial 72 hours.

Protect the concrete pavement surface from activities that cause damage and reduce texture and coefficient of friction. Do not allow soil, gravel, petroleum products, concrete, or asphalt mixes on the concrete pavement surface.

Construct crossings for traffic convenience. If authorized, you may use RSC for crossings. Do not open crossings until the Department determines that the pavement's modulus of rupture is at least 550 psi under California Test 523 or California Test 524.

Do not open concrete pavement to traffic or use equipment on the concrete pavement for 10 days after paving nor before the concrete has attained a modulus of rupture of 550 psi based on Department's testing except:

1. If the equipment is for sawing contraction joints
2. If authorized, one side of paving equipment's tracks may be on the concrete pavement after a modulus of rupture of 350 psi has been attained, provided:
 - 2.1. Unit pressure exerted on the concrete pavement by the paver does not exceed 20 psi
 - 2.2. You change the paving equipment tracks to prevent damage or the paving equipment tracks travel on protective material such as planks
 - 2.3. No part of the track is closer than 1 foot from the concrete pavement's edge

If concrete pavement damage including visible cracking occurs, stop operating paving equipment on the concrete pavement and repair the damage.

40-1.03M Early Use of Concrete Pavement

If requesting early use of concrete pavement:

1. Furnish molds and machines for modulus of rupture testing
2. Sample concrete
3. Fabricate beam specimens
4. Test for modulus of rupture under California Test 523

If you request early use, concrete pavement must have a modulus of rupture of at least 350 psi. Protect concrete pavement under section 40-1.03L.

40-1.03N Reserved

40-1.03O Shoulder Rumble Strip

40-1.03O(1) General

Construct shoulder rumble strips by rolling or grinding indentations in new concrete pavement.

Do not construct shoulder rumble strips on structures or approach slabs.

Construct rumble strips within 2 inches of the specified alignment. Rumble strip equipment must be equipped with a sighting device enabling the operator to maintain the rumble strip alignment.

Indentations must not vary from the specified dimensions by more than 1/16 inch in depth nor more than 10 percent in length and width.

Grind or remove and replace noncompliant rumble strip indentations at locations determined by the Engineer. Ground surface areas must be neat and uniform in appearance.

Remove grinding residue under section 42-1.03B.

40-1.03O(2) Rolled-In Indentations

Construct rolled-in indentations before final concrete set. Indentation construction must not displace adjacent concrete.

40-1.03O(3) Ground-In Indentations

Concrete pavement must be hardened before grinding rumble strips indentations. Do not construct indentations until the following occurs:

1. 10 days elapse after concrete placement
2. Concrete has developed a modulus of rupture of 550 psi determined under California Test 523,

40-1.03P Drilling Cores

Drill concrete pavement cores under ASTM C 42/C 42M. Use diamond impregnated drill bits.

Clean, dry, and fill core holes with hydraulic cement grout (nonshrink) or pavement concrete. Coat the core hole walls with epoxy adhesive for bonding new concrete to old concrete under section 95. Finish the backfill to match the adjacent surface elevation and texture.

40-1.03Q Pavement Repair and Replacement

40-1.03Q(1) General

If surface raveling or full-depth cracks occur within one year of Contract acceptance, repair or replace the pavement under section 6-3.06.

Repair and replace pavement in the following sequence:

1. Replace pavement
2. Repair spall, ravel, and working cracks
3. Correct smoothness and coefficient of friction
4. Treat partial depth cracks
5. Replace damaged joint seals under section 41-5

In addition to removing pavement for other noncompliance, remove and replace JPCP slabs that:

1. Have one or more full depth crack
2. Have raveled surfaces such that either:
 - 2.1. Combined raveled areas are more than 5 percent of the total slab area
 - 2.2. Single area is more than 4 sq ft

Remove and replace JPCP 3 feet on both sides of a joint with a rejected dowel bar.

40-1.03Q(2) Spall and Ravel Repair

Repair spalled or raveled areas that are:

1. Deeper than 0.05 foot
2. Wider than 0.10 foot
3. Longer than 0.3 foot

Repairs must comply with section 41-4 and be completed before opening pavement to traffic.

40-1.03Q(3) Crack Repair

Treat partial depth cracks for JPCP under section 41-3.

If the joints are sealed, repair working cracks by routing and sealing. Use a powered rotary router mounted on wheels, with a vertical shaft and a routing spindle that casters as it moves along the crack. Form a reservoir 3/4 inch deep by 3/8 inch wide in the crack. Equipment must not cause raveling nor spalling.

Treat the contraction joint adjacent to the working crack by either:

1. Epoxy resin under ASTM C 881/C 881M, Type IV, Grade 2
2. Pressure injecting epoxy resin under ASTM C 881/C881M, Type IV, Grade 1

40-1.03Q(4) Smoothness and Friction Correction

Correct pavement that is noncompliant for:

1. Smoothness by grinding under section 42-3
2. Coefficient of friction by grooving or grinding under section 42

Do not start corrective work until:

1. Pavement has cured 10 days
2. Pavement has at least a 550 psi modulus of rupture
3. Your corrective method is authorized

Correct the entire lane width. Begin and end grinding at lines perpendicular to the roadway centerline. The corrected area must have a uniform texture and appearance.

If corrections are made within areas where testing with an IP is required, retest the entire lane length with an IP under sections 40-1.01D(6)(c) and 40-1.01D(7)(b)(vii).

If corrections are made within areas where testing with a 12-foot straightedge is required, retest the corrected area with a straightedge under sections 40-1.01D(6)(c) and 40-1.01D(7)(b)(vii).

Allow 25 days for the Department's coefficient of friction retesting.

40-1.03R–40-1.03U Reserved

40-1.04 PAYMENT

The payment quantity for pavement is based on the dimensions shown.

The deduction for pavement thickness deficiency in each primary area is shown in the following table:

Deduction for Thickness Deficiency

Average thickness deficiency (foot) ^a	Deduction(\$/sq yd)
0.01	0.90
0.02	2.30
0.03	4.10
0.04	6.40
0.05	9.11

^aValues greater than 0.01 are rounded to the nearest 0.01 foot.

Shoulder rumble strips are measured by the station along each shoulder on which the rumble strips are constructed without deductions for gaps between indentations.

If the initial cores show that dowel bars or tie bars are within alignment tolerances and the Engineer orders more dowel or tie bar coring, the additional cores are paid for as change order work.

The Department does not pay for additional coring to check dowel or tie bar alignment which you request.

If the Engineer accepts a test strip and it remains as part of the paving surface, the test strip is paid for as the type of pavement involved.

If the curvature of a slab affects tie bar spacing and additional tie bars are required, no additional payment is made for the additional tie bars.

Payment for grinding existing pavement is not included in the payment for the type of pavement involved.

40-2 CONTINUOUSLY REINFORCED CONCRETE PAVEMENT

40-2.01 GENERAL

40-2.01A Summary

Section 40-2 includes specifications for constructing CRCP.

Terminal joints include saw cutting, dowel bars, drill and bond dowel bars, support slab, support slab reinforcement, tack coat, and temporary hot mix asphalt.

Expansion joints include polystyrene, support slab, support slab reinforcement, dowel bars, drill and bond dowel bars, and bond breaker.

Wide flange beam terminals include polyethylene foam, support slab, and support slab reinforcement.

Pavement anchors include cross drains, anchor reinforcement, filter fabric, and permeable material.

40-2.01B Definitions

Reserved

40-2.01C Submittals

Reserved

40-2.01D Quality Control and Assurance

40-2.01D(1) General

Reserved

40-2.01D(2) Testing for Coefficient of Thermal Expansion

For field qualification, test coefficient of thermal expansion under AASHTO T 336. The coefficient of thermal expansion must not exceed 6.0 microstrain/degree Fahrenheit.

40-2.02 MATERIALS

40-2.02A General

Class 1 permeable material, filter fabric, and slotted plastic pipe cross drain as shown for pavement anchors must comply with section 68-3.

40-2.02B Concrete

Concrete for terminal joints, support slabs, and pavement anchors must comply with section 40-1.02.

40-2.02C Transverse Bar Assembly

Instead of transverse bar and other support devices, you may use transverse bar assemblies to support longitudinal bar. Bar reinforcement and wire must comply with section 40-1.02C.

40-2.02D Wide Flange Beam

Wide flange beams and studs must be either rolled structural steel shapes under ASTM A 36/A 36M or structural steel under ASTM A 572/A 572M.

40-2.02E Joints

Joint seals for wide flange beam terminals must comply with section 51-2.02.

Joint seals for transverse expansion joints must comply with section 51-2.02.

Expanded polystyrene for transverse expansion joints must comply with section 51-2.01B(1).

40-2.03 CONSTRUCTION

40-2.03A General

Reserved

40-2.03B Test Strips

Comply with section 40-1.03C except during the evaluation, the Engineer visually checks reinforcement, dowel and tie bar placement.

40-2.03C Construction Joints

Transverse construction joints must be perpendicular to the lane line. Construct joints to allow for lap splices of the longitudinal bar. Comply with the lap splice lengths shown for CRCP.

Clean construction joint surfaces before placing fresh concrete against the joint surfaces. Remove surface laitance, curing compound, and other foreign materials.

40-2.03D Bar Reinforcement

Place bar reinforcement under section 52-1.03D, except you may request to use plastic chairs. Plastic chairs will only be considered for support directly under the transverse bars. Your request to use plastic chairs must include a sample of the plastic chair, the manufacturer's written recommendations for the applicable use and load capacity, chair spacing, and your calculation for the load on a chair for the area of bar reinforcement sitting on it. Vertical and lateral stability of the bar reinforcement and plastic chairs must be demonstrated during construction of the test strip. Obtain authorization before using the proposed plastic chairs for work after the test strip is accepted.

For transverse bar in a curve with a radius under 2,500 feet, place the reinforcement in a single continuous straight line across the lanes and aligned with the radius point as shown.

40-2.03E Wide Flange Beams

Weld stud ends with an electric arc welder completely fusing the studs to the wide flange beam. Replace studs dislodged in shipping or that can be dislodged with a hammer.

40-2.03F Repair and Replacement

40-2.03F(1) General

Requirements for repair of cracks under section 40-1.03Q do not apply to CRCP. High molecular weight methacrylate is not to be applied to cracks in CRCP.

New CRCP will be monitored for 1 year from contract acceptance or relief from maintenance, whichever is less. CRCP that develops raveling areas of 6 inches by 6 inches or greater will require partial depth repair under section 6-3.06. CRCP that develops one or more full-depth transverse cracks with faulting greater than 0.25 inch or one or more full-depth longitudinal cracks with faulting greater 0.50 inch will require full depth repair.

40-2.03F(2) Partial Depth Repair

Partial depth repair must comply with section 41-4 except:

1. Determine a rectangular boundary which extends 6 inches beyond the damaged area. The limits of saw depth must be between 2 inches from the surface to 1/2 inch above the longitudinal bars.
2. If each length of the repair boundaries is equal to or greater than 3 ft, additional reinforcement is needed for the repair area. Submit a plan for authorization before starting the repair.

40-2.03F(3) Full Depth Repair

40-2.03F(3)(a) General

Removal of CRCP must be full depth except for portion of reinforcement to remain. Provide continuity of reinforcement. Comply with section 52-6. Submit a plan for authorization, before starting the repair. Do not damage the base, concrete and reinforcement to remain. Place concrete in the removal area.

40-2.03F(3)(b) Transverse Cracks

Make initial full-depth transverse saw cuts normal to the lane line a distance of 3 feet on each side of the transverse crack.

40-2.03F(3)(c) Longitudinal Cracks

Remove the cracked area normal to the lane line for the full width of the lane a distance of 1 foot beyond the ends of the crack. You may propose alternate limits with your repair plan for authorization.

40-2.03G Reserved

40-2.04 PAYMENT

Not Used

40-3 RESERVED

40-4 JOINTED PLAIN CONCRETE PAVEMENT

40-4.01 GENERAL

40-4.01A Summary

Section 40-4 includes specifications for constructing JPCP.

40-4.01B Definitions

Reserved

40-4.01C Submittals

40-4.01C(1) General

Reserved

40-4.01C(2) Early Age Crack Mitigation System

At least 24 hours before each paving shift, submit the following information as an informational submittal:

1. Early age stress and strength predictions
2. Scheduled sawing and curing activities
3. Contingency plan if cracking occurs

40-4.01C(3)–40-4.01C(8) Reserved

40-4.01D Quality Control and Assurance

40-4.01D(1) General

Reserved

40-4.01D(2) Quality Control Plan

The QC plan must include a procedure for identifying transverse contraction joint locations relative to the dowel bars longitudinal center and a procedure for consolidating concrete around the dowel bars.

40-4.01D(3) Early Age Crack Mitigation System

For JPCP, develop and implement a system for predicting stresses and strength during the initial 72 hours after paving. The system must include:

1. Subscription to a weather service to obtain forecasts for wind speed, ambient temperatures, humidity, and cloud cover
2. Portable weather station with an anemometer, temperature and humidity sensors, located at the paving site
3. Early age concrete pavement stress and strength prediction plan
4. Analyzing, monitoring, updating, and reporting the system's predictions

40-4.01D(4)–40-4.01D(9) Reserved

40-4.02 MATERIALS

Not Used

40-4.03 CONSTRUCTION

40-4.03A General

Transverse contraction joints on a curve must be on a single straight line through the curve's radius point. If transverse joints do not align in a curve, drill a full depth 2" diameter hole under ASTM C 42/C 42M where the joint meets the adjacent slab. Fill the hole with joint filler. If joints are not sealed, avoid joint filler material penetration into the joint.

40-4.03B Repair and Replacement

If replacing concrete, saw cut and remove to full depth.

Saw cut full slabs at the longitudinal and transverse joints. Saw cut partial slabs at joints and at locations determined by the Engineer. Saw cut must be vertical.

41-1.01D(2) Reserved

41-1.02 MATERIALS

41-1.02A General

Water for washing aggregates, mixing concrete, curing, and coring must comply with section 90-1.02D.

Use the minimum amount of water to produce workable concrete and comply with the manufacturer's instructions.

41-1.02B Fast-Setting Concrete

Fast-setting concrete must be one of the following:

1. Magnesium phosphate concrete that is either:
 - 1.1. Single component water activated
 - 1.2. Dual component with a prepackaged liquid activator
2. Modified high-alumina based concrete
3. Portland cement based concrete

Fast-setting concrete must be stored in a cool and dry environment.

If used, the addition of retarders must comply with the manufacturer's instructions.

You may use any accelerating chemical admixtures complying with ASTM C494/C494M, Type C and section 90-1.02E.

Fast-setting concrete properties must have the values shown in the following table:

Fast-Setting Concrete

Property	Test method	Value
Compressive strength ^a (psi, min)		
at 3 hours	California Test 551	3,000
at 24 hours	California Test 551	5,000
Flexural strength ^a (psi, min, at 24 hours)	California Test 551	500
Bond strength ^a (psi, min, at 24 hours)		
Saturated surface dry concrete	California Test 551	300
Dry concrete	California Test 551	400
Water absorption (% , max)	California Test 551	10
Abrasion resistance ^a (g, max, at 24 hours)	California Test 550	25
Drying shrinkage (% , max, at 4 days)	ASTM C596	0.13
Water soluble chlorides ^b (% , max, by weight)	California Test 422	0.05
Water soluble sulfates ^b (% , max, by weight)	California Test 417	0.25
Thermal stability (% , min)	California Test 553	90

^aPerform test with aggregate filler if used.

^bTest must be performed on a cube specimen, fabricated under California Test 551, cured at least 14 days, and then pulverized to 100% passing the no. 50 sieve.

Aggregate filler may be used to extend prepackaged concrete. Aggregate filler must:

1. Be clean and uniformly rounded.
2. Have a moisture content of 0.5-percent by weight or less when tested under California Test 226.
3. Comply with sections 90-1.02C(2) and 90-1.02C(3).
4. Not exceed 50 percent of the concrete volume or the maximum recommended by the fast-setting concrete manufacturer, whichever is less.

When tested under California Test 202, aggregate filler must comply with the grading in the following table:

Aggregate Filler Grading

Sieve size	Percentage passing
3/8 inch	100
No. 4	50–100
No. 16	0–5

41-1.02C Polyester Concrete

Polyester concrete consists of polyester resin binder and dry aggregate. The polyester resin binder must be an unsaturated isophthalic polyester-styrene copolymer.

Polyester resin binder properties must have the values shown in the following table:

Polyester Resin Binder		
Property	Test method	Value
Viscosity ^a (Pa·s) RVT, No. 1 spindle, 20 RPM at 77 °F	ASTM D2196	0.075– 0.200
Specific gravity ^a (77 °F)	ASTM D1475	1.05–1.10
Elongation (%), min) Type I specimen, 0.25 ± 0.03 inch thick Speed of testing = 0.45 inch/minute Condition 18/25/50+5/70: T—23/50	ASTM D638	35
Tensile strength (psi), min) Type I specimen, 0.25 ± 0.03 inch thick Speed of testing = 0.45 inch/minute Condition 18/25/50+5/70: T—23/50	ASTM D638	2,500
Styrene content ^a (%), by weight)	ASTM D2369	40–50
Silane coupler (%), min, by weight of polyester resin binder)	--	1.0
PCC saturated surface-dry bond strength at 24 hours and 70 ± 2 °F (psi, min)	California Test 551	500
Static volatile emissions ^a (g/sq m, max)	South Coast Air Quality Management District, Method 309-91 ^b	60

^aPerform the test before adding initiator.

^bFor the test method, go to:

<http://www.aqmd.gov/tao/methods/lab/309-91.pdf>

Silane coupler must be an organosilane ester, gamma-methacryloxypropyltrimethoxysilane. Promoter must be compatible with suitable methyl ethyl ketone peroxide (MEKP) and cumene hydroperoxide (CHP) initiators.

Aggregate for polyester concrete must comply with section 90-1.02C(1), 90-1.02C(2), and 90-1.02C(3).

When tested under California Test 202, the combined aggregate grading must comply with one of the gradations in the following table:

Combined Aggregate Grading

Sieve size	Percentage passing		
	A	B	C
1/2"	100	100	100
3/8"	83–100	100	100
No. 4	65–82	62–85	45–80
No. 8	45–64	45–67	35–67
No. 16	27–48	29–50	25–50
No. 30	12–30	16–36	15–36
No. 50	6–17	5–20	5–20
No. 100	0–7	0–7	0–9
No. 200	0–3	0–3	0–6

Aggregate retained on the no. 8 sieve must have a maximum of 45 percent crushed particles under California Test 205. Fine aggregate must be natural sand.

The weighted average absorption must not exceed 1 percent when tested under California Tests 206 and 207.

You may submit an alternative grading or request to use manufactured sand as fine aggregate but 100 percent of the combined grading must pass the 3/8 inch sieve. Allow 21 days for authorization.

Polyester concrete must have a minimum compressive strength of 1250 psi at 3 hours and 30 minutes under California Test 551 or ASTM C109.

41-1.02D Bonding Agent

Bonding agent must comply with the concrete manufacturer's recommendations.

41-1.02E Temporary Pavement Structure

Temporary pavement structure consists of RSC or aggregate base with HMA. RSC not conforming to the specifications may serve as temporary pavement structure if:

1. The modulus of rupture is at least 200 psi before opening to traffic
2. RSC thickness is greater than or equal to the existing concrete pavement surface layer
3. RSC is replaced during the next paving shift

Aggregate base for temporary pavement structure must comply with the 3/4-inch maximum grading specified in section 26-1.02B.

04-18-14

HMA must comply with the specifications for minor HMA in section 39.

41-1.02F Reserved**41-1.03 CONSTRUCTION****41-1.03A General**

Repair only the portion of pavement where the work will be completed during the same lane closure. If removal is required, remove only the portion of pavement where the repair will be completed during the same traffic closure. Completion of concrete repair includes curing until the concrete attains the specified minimum properties required before opening the repaired pavement to traffic.

If you fail to complete the concrete pavement repair during the same lane closure, construct temporary pavement before opening the lane to traffic.

Before starting repair work, except saw cutting: the equipment, materials, and personnel for constructing temporary pavement structure must be at the job site or an approved location. If HMA can be delivered to the job site within 1 hour, you may request 1-hour delivery as an alternative to having the HMA at the job site.

Maintain the temporary pavement structure and replace it as a first order of work as soon as you resume concrete pavement repair work.

After removing temporary pavement structure, you may stockpile that aggregate base at the job site and reuse it for temporary pavement structure.

41-1.03B Mixing and Applying Bonding Agent

Mix and apply the bonding agent at the job site under the manufacturer's instructions and in small quantities.

Apply bonding agent after cleaning the surface and before placing concrete.

Apply a thin, even coat of bonding agent with a stiff bristle brush until the entire repair surface is scrubbed and coated with bonding agent.

41-1.03C Mixing Concrete**41-1.03C(1) General**

Mix concrete in compliance with the manufacturer's instructions. For repairing spalls, mix in a small mobile drum or paddle mixer. Comply with the manufacturer's recommended limits for the quantity of aggregate filler, water, and liquid activator.

Mix the entire contents of prepackaged dual-component magnesium phosphate concrete as supplied by the manufacturer. Use the full amount of each component and do not add water to dual-component magnesium phosphate concrete.

Magnesium phosphate concrete must not be mixed in containers or worked with tools containing zinc, cadmium, aluminum, or copper.

Modified high-alumina based concrete must not be mixed in containers or worked with tools containing aluminum.

41-1.03C(2) Polyester Concrete

When mixing with resin, the moisture content of the combined aggregate must not exceed 1/2 of the average aggregate absorption when tested under California Test 226.

Proportion the polyester resin and aggregate to produce a mixture with suitable workability for the intended work. Only a minimal amount of resin may rise to the surface after finishing.

41-1.03D Placing Concrete

The pavement surface temperature must be at least 40 degrees F before placing concrete. You may propose methods to heat the surfaces.

Place magnesium phosphate concrete on a dry surface.

Place portland cement and modified high-alumina concrete on surfaces treated with a bonding agent recommended by the concrete manufacturer. If no bonding agent is recommended by the manufacturer, place concrete on damp surfaces that are not saturated.

Do not retemper concrete. Use dry finishing tools cleaned with water before working the concrete.

41-1.03E Curing Concrete

Cure concrete under the manufacturer's instructions. When curing compound is used, comply with section 90-1.03B for curing compound no. 1 or 2.

41-1.03F Reserved

41-1.04 PAYMENT

Not Used

41-2 SUBSEALING AND JACKING

41-2.01 GENERAL

41-2.01A Summary

Section 41-2 includes specifications for filling voids under existing concrete pavement.

41-2.01B Definitions

Reserved

41-2.01C Submittals

Submit shipping invoices with packaged or bulk fly ash and cement.

Before grouting activities begin, submit a proposal for the materials to be used. Include authorized laboratory test data for the grout indicating:

1. Time of initial setting under ASTM C266.
2. Compressive strength results at 1, 3, and 7 days for 10, 12, and 14-second grout efflux times.

If requesting a substitution of grout materials, submit a proposal that includes test data.

41-2.01D Quality Control and Assurance

Reserved

41-2.02 MATERIALS

41-2.02A General

Reserved

41-2.02B Grout

Grout must consist of Type II portland cement, fly ash, and water. Use from 2.4 to 2.7 parts fly ash to 1 part portland cement by weight. Use enough water to produce the following grout efflux times determined under California Test 541, Part D:

1. From 10 to 16 seconds for subsealing
2. From 10 to 26 seconds for jacking

Cement for grout must comply with the specifications for Type II portland cement in section 90-1.02B(2).

Fly ash must comply with AASHTO M 295, Class C or Class F. Fly ash sources must be on the Authorized Material List.

You may use chemical admixtures and calcium chloride. Chemical admixtures must comply with section 90-1.02E(2). Calcium chloride must comply with ASTM D98.

Test grout compressive strength under California Test 551, Part 1 at 7-days with 12 seconds efflux time. Follow the procedures for moist cure. The 7-day compressive strength must be at least 750 psi.

41-2.02C Mortar

Mortar must be a prepackaged fast-setting mortar that complies with ASTM C928.

41-2.02D Reserved

41-2.03 CONSTRUCTION

41-2.03A General

Drill holes in the pavement, inject grout, plug the holes, and finish the holes with mortar.

Drill holes through the pavement and underlying base to a depth from 15 to 18 inches below the pavement surface. The hole diameter must match the fitting for the grout injecting equipment.

41-2.03B Injecting Grout

41-2.03B(1) General

Inject grout within 2 days of drilling holes.

Immediately before injecting grout, clean the drilled holes with water at a minimum pressure of 40 psi. The cleaning device must have at least 4 jets that direct water horizontally at the slab-base interface.

Do not inject grout if the atmospheric or subgrade temperature is below 40 degrees F. Do not inject grout in inclement weather. If water is present in the holes, obtain the Engineer's authorization before injecting grout.

Do not inject grout until at least 2 consecutive slabs requiring subsealing are drilled ahead of the grouting activities.

The grout plant must have a positive displacement cement injection pump and a high-speed colloidal mixer capable of operating from 800 to 2,000 rpm. The injection pump must sustain 150 psi if pumping grout with a 12-second efflux time. A pressure gauge must be located immediately adjacent to the supply valve of the grout hose supply valve and positioned for easy monitoring.

Before mixing, weigh dry cement and fly ash if delivered in bulk. If the materials are packaged, each container must weigh the same.

Introduce water to the mixer through a meter or scale.

Inject grout under pressure until the voids under the pavement slab are filled. The injection nozzle must not leak. Do not inject grout if the nozzle is below the bottom of the slab. Inject grout 1 hole at a time.

Stop injecting grout in a hole if either:

1. Grout does not flow under a sustained pump gauge pressure of 150 psi after 7 seconds and there is no indication the slab is moving.
2. Injected grout rises to the surface at any joint or crack, or flows into an adjacent hole.

Dispose of unused grout within 1 hour of mixing.

41-2.03B(2) Subsealing

If a slab raises more than 1/16 inch due to grout injection, stop injecting grout in that hole.

41-2.03B(3) Jacking

The positive displacement pump used for grout injection must be able to provide a sustained gauge pressure of 200 psi. Gauge pressures may be from 200 to 600 psi for brief periods to start slab movement.

You may add additional water to initiate pressure injection of grout. Do not reduce the grout efflux time below 10 seconds.

Raise the slabs uniformly. Use string lines to monitor the pavement movement.

Do not move adjacent slabs not specified for pavement jacking. If you move adjacent slabs, correct the grade within the tolerances for final pavement elevation.

41-2.03B(4) Finishing

Immediately after removing the injection nozzle, plug the hole with a round, tapered wooden plug. Do not remove plugs until adjacent holes are injected with grout and no grout surfaces through previously injected holes.

After grouting, remove grout from drilled holes at least 4 inches below the pavement surface. Clean holes and fill with mortar. Finish filled holes flush with the pavement surface.

41-2.03B(5) Tolerances

The final pavement elevation must be within 0.01 foot of the required grade. If the final pavement elevation is between 0.01 and 0.10 foot higher than the required grade, grind the noncompliant pavement surface under section 42 to within 0.01 foot of the required grade.

If the final pavement elevation is higher than 0.10 foot from the required grade, remove and replace the noncompliant pavement under section 41-9.

41-2.04 PAYMENT

The payment quantity for subsealing is calculated by adding the dry weight of cement and fly ash used for the placed grout. The payment quantity for jacking is calculated by adding the dry weight of cement and fly ash used for the placed grout.

The Department does not pay for wasted grout.

The Department does not adjust the unit price for an increase or decrease in the subsealing quantity.

The Department does not adjust the unit price for an increase or decrease in the jacking quantity.

41-3 CRACK TREATMENT

41-3.01 GENERAL

41-3.01A Summary

Section 41-3 includes specifications for applying high-molecular-weight methacrylate (HMWM) to concrete pavement surface cracks that do not extend the full slab depth.

41-3.01B Definitions

Reserved

41-3.01C Submittals

41-3.01C(1) General

Submit HMWM samples 20 days before use.

If sealant is to be removed, submit the proposed removal method at least 7 days before sealant removal. Do not remove sealant until the proposed sealant removal method is authorized.

41-3.01C(2) Public Safety and Placement Plans

Before starting crack treatment, submit a public safety plan for HMWM and a placement plan for construction activity as shop drawings.

The public safety and placement plans must identify the materials, equipment, and methods to be used.

In the public safety plan, include the MSDS for each component of HMWM and details for:

1. Shipping
2. Storage
3. Handling
4. Disposal of residual HMWM and containers

If the project is in an urban area adjacent to a school or residence, the public safety plan must also include an airborne emissions monitoring plan prepared by a CIH certified in comprehensive practice by the American Board of Industrial Hygiene. Submit a copy of the CIH's certification. The CIH must monitor the emissions at a minimum of 4 points including the mixing point, the application point, and the point of nearest public contact. At work completion, submit a report by the industrial hygienist with results of the airborne emissions monitoring plan.

The placement plan must include:

1. Crack treatment schedule including coefficient of friction testing
2. Methods and materials including:
 - 2.1. Description of equipment for applying HMWM
 - 2.2. Description of equipment for applying sand
 - 2.3. Gel time range and final cure time for resin

Revise rejected plans and resubmit. With each plan rejection, the Engineer gives revision directions including detailed comments in writing. The Engineer notifies you of a plan's acceptance or rejection within 2 weeks of receiving that plan.

41-3.01C(3) Reserved

41-3.01D Quality Control and Assurance

41-3.01D(1) General

Use test tiles to evaluate the HMWM cure time. Coat at least one 4 by 4 inch smooth glazed tile for each batch of HMWM. Place the coated tile adjacent to the area being treated. Do not apply sand to the test tiles.

Use the same type of crack treatment equipment for testing and production.

41-3.01D(2) Test Area

Before starting crack treatment, treat a test area of at least 500 square feet within the project limits at a location accepted by the Engineer. Use test areas outside the traveled way if available.

Treat the test area under weather and pavement conditions similar to those expected during crack treatment production.

The Engineer evaluates the test area based on the acceptance criteria. Do not begin crack treatment until the Engineer accepts the test area.

41-3.01D(3) Reserved

41-3.01D(4) Acceptance Criteria

The Engineer accepts a treated area if:

1. Corresponding test tiles are dry to the touch
2. Treated surface is tack-free and not oily
3. Sand cover adheres enough to resist hand brushing
4. Excess sand is removed
5. Coefficient of friction is at least 0.30 when tested under California Test 342

41-3.02 MATERIALS

HMWM consists of compatible resin, promoter, and initiator. HMWM resin may be prepromoted by mixing promoter and resin together before filling containers. Identify prepromoted resin on the container label.

Adjust the gel time to compensate for temperature changes throughout the application.

HMWM resin properties must have the following values:

Property	Test method	Value
Viscosity ^a (cP, max, Brookfield RVT with UL adapter, 50 RPM at 77 °F)	ASTM D2196	25
Specific gravity ^a (min, at 77 °F)	ASTM D1475	0.90
Flash point ^a (°F, min)	ASTM D3278	180
Vapor pressure ^a (mm Hg, max, at 77 °F)	ASTM D323	1.0
Tack-free time (minutes, max, at 77 °F)	Specimen prepared under California Test 551	400
Volatile content ^a (% , max)	ASTM D2369	30
PCC saturated surface-dry bond strength (psi, min, at 24 hours and 77 ± 2 °F)	California Test 551	500

^aPerform the test before adding initiator.

Sand must be commercial quality dry blast sand. At least 95 percent of the sand must pass the no. 8 sieve and at least 95 percent must be retained on the no. 20 sieve when tested under California Test 202.

41-3.02D Reserved

41-3.03 CONSTRUCTION

41-3.03A General

Before applying HMWM, clean the pavement surface by abrasive blasting and blow loose material from visible cracks with high-pressure air. Remove concrete curing seals from the pavement to be treated. The pavement must be dry when blast cleaning is performed. If the pavement surface becomes contaminated before applying the HMWM, clean the pavement surface by abrasive blasting.

If performing abrasive blasting within 10 feet of a lane occupied by traffic, operate abrasive blasting equipment with a concurrently operating vacuum attachment.

During pavement treatment, protect pavement joints, working cracks, and surfaces not being treated.

The equipment applying HMWM must combine the components by either static in-line mixers or by external intersecting spray fans. The pump pressure at the spray bars must not cause atomization. Do not use compressed air to produce the spray. Use a shroud to enclose the spray bar apparatus.

You may apply HMWM manually to prevent overspray onto adjacent traffic. If applying resin manually, limit the batch quantity of HMWM to 5 gallons.

Apply HMWM at a rate of 90 square feet per gallon. The prepared area must be dry and the surface temperature must be from 50 to 100 degrees F while applying HMWM. Do not apply HMWM if the ambient relative humidity is more than 90 percent.

Protect existing facilities from HMWM. Repair or replace existing facilities contaminated with HMWM at your expense.

Flood the treatment area with HMWM to penetrate the pavement and cracks. Apply HMWM within 5 minutes after complete mixing. Mixed HMWM viscosity must not increase. Redistribute excess material with squeegees or brooms within 10 minutes of application. Remove excess material from tined grooves.

Wait at least 20 minutes after applying HMWM before applying sand. Apply sand at a rate of approximately 2 pounds per square yard or until refusal. Remove excess sand by vacuuming or sweeping.

Do not allow traffic on the treated surface until:

1. Treated surface is tack-free and non-oily
2. Sand cover adheres enough to resist hand brushing
3. Excess sand is removed
4. Coefficient of friction is at least 0.30 determined under California Test 342

41-3.04 PAYMENT

Not Used

41-4 SPALL REPAIR

41-4.01 GENERAL

Section 41-4 includes specifications for repairing spalls in concrete pavement.

41-4.02 MATERIALS

Repair spalls using polyester concrete with a bonding agent. The bonding agent must comply with the requirements for HMWM in section 41-3.02 except tack-free time requirements do not apply and the HMWM must not contain wax.

Form board must be corrugated cardboard with a 6-mil polyethylene covering.

41-4.03 CONSTRUCTION

41-4.03A General

Prepare spall areas by removing concrete and cleaning. Use a form board to provide compression relief at joints and cracks.

After completing spall repairs do not allow traffic on the repairs for at least 2 hours after the time of final setting under ASTM C403/403M.

41-4.03B Remove Pavement

The Engineer determines the rectangular limits of unsound concrete pavement. Before removing pavement, mark the saw cut lines and spall repair area on the pavement surface.

Do not remove pavement until the Engineer verbally authorizes the saw cut area.

Use a power-driven saw with a diamond blade.

Remove pavement as shown and:

1. From the center of the repair area towards the saw cut
2. To the full saw cut depth
3. At least 2 inches beyond the saw cut edge to produce a rough angled surface

Produce a rough surface by chipping or other removal methods that do not damage the pavement remaining in-place. Completely remove any saw overcuts. Pneumatic hammers used for concrete removal must weigh 15 lbs or less.

If you damage concrete pavement outside the removal area, enlarge the area to remove the damaged pavement.

If dowel bars are exposed during removal, remove concrete from the exposed surface and cover with duct tape.

41-4.03C Cleaning

After pavement has been removed, clean the exposed faces of the concrete by:

1. Sand or water blasting. Water blasting equipment must be capable of producing a blast pressure of 3,000 to 6,000 psi.
2. Blowing the exposed concrete area with compressed air free of moisture and oil to remove debris after blasting. Air compressors must deliver air at a minimum of 120 cfm and develop 90 psi of nozzle pressure.

41-4.03D Form Board Installation

After cleaning, place the form board to match the existing joint or crack alignment. Extend the form board at least 3 inches beyond each end of the repair and at least 1 inch deeper than the repair. Remove the form board before sealing joints or cracks.

41-4.03E–41-4.03I Reserved

41-4.04 PAYMENT

Payment is calculated based on the authorized saw cut area.

The Department does not adjust the unit price for an increase or decrease in the spall repair quantity.

41-5 JOINT SEALS

41-5.01 GENERAL

41-5.01A Summary

Section 41-5 includes specifications for sealing concrete pavement joints or replacing existing concrete pavement joint seals. Pavement joints include isolation joints.

41-5.01B Definitions

Reserved

41-5.01C Submittals

At least 15 days before delivery to the job site, submit a certificate of compliance, MSDS, manufacturer's recommendations, and instructions for storage and installation of:

1. Liquid joint sealant.
2. Backer rods. Include the manufacturer data sheet verifying compatibility with the liquid joint sealant.
3. Preformed compression joint seal. Include the manufacturer data sheet used to verify the seal for the joint dimensions shown.
4. Lubricant adhesive.

Asphalt rubber joint sealant containers must comply with ASTM D6690. Upon delivery of asphalt rubber joint sealant to the job site, submit a certified test report for each lot based on testing performed within 12 months.

Submit a work plan for removing pavement and joint materials. Allow 10 days for authorization. Include descriptions of the equipment and methods for removal of existing pavement and joint material.

41-5.01D Quality Control and Assurance

41-5.01D(1) General

Before sealing joints, arrange for a representative from the manufacturer to provide training on cleaning and preparing the joint and installing the liquid joint sealant or preformed compression joint seal. Do not seal joints until your personnel and the Department's personnel have been trained.

The Engineer accepts joint seals based on constructed dimensions and visual inspection of completed seals for voids.

41-5.01D(2) Reserved

41-5.02 MATERIALS

41-5.02A General

Use the type of seal material described.

Silicone or asphalt rubber joint sealant must not bond or react with the backer rod.

41-5.02B Silicone Joint Sealant

Silicone joint sealant must be on the Authorized Material List.

41-5.02C Asphalt Rubber Joint Sealant

Asphalt rubber joint sealant must:

1. Be paving asphalt mixed with not less than 10 percent ground rubber by weight. Ground rubber must be vulcanized or a combination of vulcanized and devulcanized materials that pass a no. 8 sieve.
2. Comply with ASTM D6690 for Type II.

3. Be capable of melting at a temperature below 400 degrees F and applied to cracks and joints.

41-5.02D Backer Rods

Backer rods must:

1. Comply with ASTM D5249:
 - 1.1. Type 1 for asphalt rubber joint sealant
 - 1.2. Type 1 or Type 3 for silicone joint sealant
2. Be expanded, closed-cell polyethylene foam
3. Have a diameter at least 25 percent greater than the saw cut joint width

41-5.02E Preformed Compression Joint Seals

Preformed compression joint seals must:

1. Comply with ASTM D2628
2. Have 5 or 6 cells, except seals 1/2 inch wide or less may have 4 cells

Lubricant adhesive used to install seals must comply with ASTM D2835.

41-5.02F–41-5.02K Reserved

41-5.03 CONSTRUCTION

41-5.03A General

If joint sealing is described for new concrete pavement, do not start joint sealing activities until the pavement has been in place for at least 7 days. Seal new concrete pavement joints at least 7 days after concrete pavement placement if shown.

Remove existing pavement and joint material by sawing, rectangular plowing, cutting, or manual labor. Saw cut the reservoir before cleaning the joint. Use a power-driven saw with a diamond blade.

If you damage a portion of the pavement to remain in place, repair the pavement under section 41-4.

41-5.03B Joint Cleaning

41-5.03B(1) General

Clean the joint after removal and any repair is complete before installing joint seal material. Cleaning must be completed no more than 4 hours before installing backer rods, liquid joint seal, or preformed compression seals using the following sequence:

1. Removing debris
2. Drying
3. Sandblasting
4. Air blasting
5. Vacuuming

Clean in 1 direction to minimize contamination of surrounding areas.

41-5.03B(2) Removing Debris

Remove debris including dust, dirt, and visible traces of old sealant from the joint after sawing, plowing, cutting, or manual removal. Do not use chemical solvents to wash the joint.

41-5.03B(3) Drying

After removing debris, allow the reservoir surfaces to dry or remove moisture and dampness at the joint with compressed air that may be moderately hot.

41-5.03B(4) Sandblasting

After the joint is dry, sandblast the reservoir to remove remaining residue using a 1/4-inch diameter nozzle and 90 psi minimum pressure. Do not sandblast straight into the reservoir. Angle the sandblasting nozzle within 1 to 2 inches from the concrete and make at least 1 pass to clean each reservoir face.

41-5.03B(5) Air Blasting

After sandblasting, air blast the reservoir to remove sand, dirt, and dust 1 hour before sealing the joint. Use compressed air free of oil and moisture delivered at a minimum rate of 120 cfm and 90 psi nozzle pressure.

41-5.03B(6) Vacuuming

After air blasting, use a vacuum sweeper to remove debris and contaminants from the pavement surfaces surrounding the joint.

41-5.03B(7) Reserved

41-5.03C Installing Liquid Joint Sealant

Where backer rods are shown, place the rods before installing liquid joint sealant. Place backer rods under the manufacturer's instructions unless otherwise specified. The pavement and reservoir surfaces must be dry and the ambient air temperature must be at least 40 degrees F and above the dew point. The reservoir surface must be free of residue or film. Do not puncture the backer rod.

Immediately after placing the backer rod, install liquid joint sealant under the manufacturer's instructions unless otherwise specified. Before installing, demonstrate that fresh liquid sealant is ejected from the nozzle free of cooled or cured material. For asphalt rubber joint sealant, the pavement surface temperature must be at least 50 degrees F before installing.

Pump liquid joint sealant through a nozzle sized for the width of the reservoir so that liquid joint sealant is placed directly onto the backer rod. The installer must draw the nozzle toward his body and extrude liquid joint sealant evenly. Liquid joint sealant must maintain continuous contact with the reservoir walls during extrusion.

After placing liquid joint sealant, recess it to the depth shown within 10 minutes of installation and before a skin begins to form.

After each joint is sealed, remove excess liquid joint sealant on the pavement surface. Do not allow traffic over the sealed joints until the liquid joint sealant is set, tack free, and firm enough to prevent embedment of roadway debris.

41-5.03D Installing Preformed Compression Joint Seals

Install preformed compression joint seals using lubricant adhesive as shown and under the manufacturer's instructions.

Install longitudinal seals before transverse seals. Longitudinal seals must be continuous except splicing is allowed at intersections with transverse seals. Transverse seals must be continuous for the entire transverse length of concrete pavement except splices are allowed for widening and staged construction. With a sharp instrument, cut across the longitudinal seal at the intersection with transverse construction joints. If the longitudinal seal does not relax enough to properly install the transverse seal, trim the longitudinal seal to form a tight seal between the 2 joints.

If splicing is authorized, comply with the manufacturer's instructions.

Use a machine specifically designed for preformed compression joint seal installation. The machine must install the seal:

1. To the specified depth
2. To make continuous contact with the joint walls
3. Without cutting, nicking, or twisting the seal
4. Without stretching the seal more than 4 percent

Cut preformed compression joint seal material to the exact length of the pavement joint to be sealed. The Engineer measures this length. After you install the preformed compression joint seal, the Engineer measures the excess length of material at the joint end. The Engineer divides the excess length by the measured cut length to determine the stretch percentage.

Seals must be compressed from 30 to 50 percent of the joint width when complete in place.

41-5.03E Reserved

41-5.04 PAYMENT

Not Used

41-6 CRACK AND SEAT

41-6.01 GENERAL

41-6.01A Summary

Section 41-6 includes specifications for cracking, seating, and preparing the surface of existing concrete pavement.

41-6.01B Definitions

Reserved

41-6.01C Submittals

Submit each core in a plastic bag or tube for acceptance at the time of sampling. Mark each core with a location description.

41-6.01D Quality Control and Assurance

41-6.01D(1) General

If cracking is noncompliant:

1. Stop crack and seat work
2. Modify your equipment and procedures and crack the noncompliant pavement again
3. Construct another test section
4. Take additional core samples to verify compliance
5. Construct an inspection strip if the concrete pavement has HMA on the surface

41-6.01D(2) Test Section

The Engineer determines and marks a test section up to 1000 square feet within the crack and seat area shown. Construct the test section and obtain the Engineer's verbal authorization before starting crack and seat work.

Immediately before cracking the test section, apply water to the pavement surface so that cracking can be readily evaluated. Crack the test section and vary impact energy and striking patterns to verify your procedure.

41-6.01D(3) Coring

Drill cores at least 6 inches in diameter under ASTM C42 to verify cracking in the Engineer's presence. Take at least 2 cores per test section and 1 core per lane mile for each pavement cracking machine used. The Engineer determines the core locations.

41-6.01D(4) Reserved

41-6.02 MATERIALS

41-6.02A General

Use fast-setting or polyester concrete to fill core holes.

41-6.03 CONSTRUCTION

41-6.03A Cracking

Crack existing concrete pavement using the procedures and equipment from the authorized test section. Do not allow flying debris during cracking operations.

Crack existing concrete pavement into segments that nominally measure 6 feet transversely by 4 feet longitudinally. If the existing pavement is already cracked into segments, crack it into equal-sized square or rectangular pieces that nominally measure not more than 6 feet transversely and from 3 to 5 feet longitudinally. Do not impact the pavement within 1 foot of another break line, pavement joint, or edge of pavement.

Cracks must be vertical, continuous, and penetrate the full depth of pavement. Cracks must be within 6 inches of vertical along the full depth of pavement. Do not cause surface spalling over 0.10-foot deep or excessive shattering of the pavement or base.

Cracking equipment must impact the pavement with a variable force in a controlled location. Do not use unguided free-falling weights such as "headache balls."

If the concrete pavement has no more than 0.10 foot of asphalt concrete on the surface, you may crack the pavement without removing the asphalt concrete. After cracking, construct an inspection strip by removing at least 500 square feet of asphalt concrete at a location determined by the Engineer. Construct additional inspection strips to demonstrate compliance where ordered by the Engineer.

After cracking, allow public traffic on the cracked or initial pavement layer for no more than 15 days.

41-6.03B Seating

Seat cracked concrete by making at least 5 passes over the cracked concrete with either:

04-18-14

1. Oscillating type pneumatic-tired roller at least 4 feet wide. Pneumatic tires must be of equal size, diameter, type, and ply. The tires must be inflated to 60 psi minimum and maintained so that the air pressure does not vary more than 5 psi. The roller's gross static weight must be at least 15 tons.

07-19-13

2. Vibratory pad-foot roller exerting a dynamic centrifugal force of at least 10 tons

A pass is 1 movement of a roller in either direction at 5 mph or less.

After all segments have been seated, clean loose debris from joints and cracks using compressed air free of moisture and oil.

Reseat any segment of cracked pavement that has not been overlaid within 24 hours of seating.

41-6.03C Surface Preparation

Before opening cracked and seated pavement to traffic or overlaying:

04-18-14

1. Fill joints, cracks, and spalls wider than 3/4 inch and deeper than 1 inch by applying tack coat and placing minor HMA under section 39. Use the no. 4 gradation.
2. Remove all loose debris and sweep the pavement.

07-19-13

41-6.03D Reserved

41-6.04 PAYMENT

Crack and seat existing concrete pavement is measured from the area of pavement cracked and seated. No deduction is made for existing cracked segments. The Department does not pay for HMA used to fill joints, cracks, and spalls.

41-7 TRANSITION TAPER

41-7.01 GENERAL

Section 41-7 includes specifications for constructing transition tapers in existing pavement.

41-7.02 MATERIALS

Not Used

41-7.03 CONSTRUCTION

Construct transition tapers by either grinding or removing and replacing the existing concrete. Do not allow flying debris during the construction of tapers.

Grinding must comply with section 42.

Replacement concrete must comply with section 41-9 except place concrete to the taper level shown and finish the surface with a coarse broom.

04-18-14

If the transition taper will be overlaid with HMA that is not placed before opening to traffic and there is a grade difference of more than 0.04 foot, construct a temporary taper by placing minor HMA that complies with section 39. Remove the temporary HMA taper before constructing the transition taper.

07-19-13

41-7.04 PAYMENT

Pavement transition tapers are measured using the dimensions shown. The Department does not pay for temporary HMA tapers.

41-8 DOWEL BAR RETROFIT

Reserved

41-9 INDIVIDUAL SLAB REPLACEMENT WITH RAPID STRENGTH CONCRETE

41-9.01 GENERAL

41-9.01A Summary

Section 41-9 includes specifications for removing existing concrete pavement and constructing individual slab replacement with rapid strength concrete (ISR—RSC).

41-9.01B Definitions

concrete raveling: Disintegration of the concrete surface layer from aggregate loss.

early age: Any age less than 10 times the time of final setting for concrete determined under ASTM C403/C403M.

full-depth crack: Crack that runs from one edge of the concrete slab to the opposite or adjacent side of the slab.

opening age: Age when the minimum modulus of rupture specified for opening to traffic and equipment is attained.

time of final setting: Elapsed time required to develop a concrete penetration resistance that is at least 4,000 psi under ASTM C403/C403M.

41-9.01C Submittals

41-9.01C(1) General

At least 15 days before delivery to the job site, submit manufacturer's recommendations, MSDS and instructions for storage and installation of joint filler material.

At least 45 days before starting ISR—RSC work submit a sample of cement from each proposed lot and samples of proposed admixtures in the quantities ordered by the Engineer.

During ISR—RSC placement operations, submit uniformity reports for hydraulic cement at least once every 30 days to the Engineer and METS, attention Cement Laboratory. Uniformity reports must comply with ASTM C917 except testing age and water content may be modified to suit the particular material.

Except for modulus of rupture tests, submit QC test result forms within 48 hours of the paving shift. Submit modulus of rupture results within:

1. 15 minutes of opening age test completion
2. 24 hours of 3-day test completion

41-9.01C(2) Quality Control Plan

If the quantity of ISR—RSC is at least 300 cu yd, submit a QC plan at least 20 days before placing trial slabs. If the quantity of ISR—RSC is less than 300 cu yd, submit proposed forms for RSC inspection, sampling, and testing.

41-9.01C(3) Mix Design

At least 10 days before use in a trial slab, submit a mix design. The maximum ambient temperature range for a mix design is 18 degrees F. Submit more than 1 mix design based on ambient temperature variations anticipated during RSC placement. Each mix design must include:

1. Mix design identification number
2. Aggregate source
3. Opening age
4. Aggregate gradation
5. Types of cement and chemical admixtures
6. Mix proportions
7. Maximum time allowed between batching and placing
8. Range of effective ambient temperatures
9. Time of final setting

10. Modulus of rupture development data from laboratory-prepared samples, including tests at:
 - 10.1. 1 hour before opening age
 - 10.2. Opening age
 - 10.3. 1 hour after opening age
 - 10.4. 1 day
 - 10.5. 3 days
 - 10.6. 7 days
 - 10.7. 28 days
11. Shrinkage test data
12. Any special instructions or conditions such as water temperature requirements

41-9.01C(4) Reserved

41-9.01D Quality Control and Assurance

41-9.01D(1) General

Designate a QC manager and assistant QC managers to administer the QC plan. The QC managers must hold current American Concrete Institute (ACI) certification as a Concrete Field Testing Technician-Grade I and a Concrete Laboratory Testing Technician-Grade II, except the assistant QC managers may hold Concrete Laboratory Testing Technician-Grade I instead of Grade II.

The QC manager responsible for the production period involved must review and sign the sampling, inspection, and test reports before submitting them. The QC manager must be present for:

1. Each stage of mix design
2. Trial slab construction
3. Production and construction of RSC
4. Meetings with the Engineer relating to production, placement, or testing

The QC manager must not be a member of this project's production or paving crews, an inspector, or a tester. The QC manager must have no duties during the production and placement of RSC except those specified.

Testing laboratories and equipment must comply with the Department's Independent Assurance Program. At the time of the QC plan submittal, the Department evaluates the quality control samplers and testers.

41-9.01D(2) Just-in-time Training

Reserved

41-9.01D(3) Quality Control Plan

Establish, implement, and maintain a QC plan for pavement. The QC plan must describe the organization and procedures used to:

1. Control the production process
2. Determine if a change to the production process is needed
3. Implement a change

The QC plan must include:

1. Names, qualifications, and certifications of QC personnel, including:
 - 1.1. QC manager
 - 1.2. Assistant QC managers
 - 1.3. Samplers and testers
2. Outline of procedure for the production, transportation, placement, and finishing of RSC
3. Outline of procedure and forms for concrete QC, sampling, and testing to be performed during and after RSC construction, including testing frequencies for modulus of rupture
4. Contingency plan for identifying and correcting problems in production, transportation, placement, or finishing RSC including:
 - 4.1. Action limits
 - 4.2. Suspension limits that do not exceed specified material requirements
 - 4.3. Detailed corrective action if limits are exceeded
 - 4.4. Temporary pavement structure provisions, including:
 - 4.4.1. The quantity and location of standby material
 - 4.4.2. Determination of need
5. Location of your quality control testing laboratory and testing equipment during and after paving operations
6. List of the testing equipment to be used, including the date of last calibration
7. Production target values for material properties that impact concrete quality or strength including cleanness value and sand equivalent
8. Outline procedure for placing and testing trial slabs, including:
 - 8.1. Locations and times
 - 8.2. Production procedures
 - 8.3. Placing and finishing methods
 - 8.4. Sampling methods, sample curing, and sample transportation
 - 8.5. Testing and test result reporting
9. Name of source plant with approved Material Plant Quality Program (MPQP)
10. Procedures or methods for controlling pavement quality including:
 - 10.1. Materials quality
 - 10.2. Contraction and construction joints
 - 10.3. Protecting pavement before opening to traffic

41-9.01D(4) Prepaving Conference

Schedule a prepaving conference and provide a facility to meet with the Engineer.

Prepaving conference attendees must sign an attendance sheet provided by the Engineer. The prepaving conference must be attended by your:

1. Project superintendent

2. Project manager
3. QC manager
4. Workers and your subcontractor's workers, including:
 - 4.1. Foremen
 - 4.2. Concrete plant manager
 - 4.3. Concrete plant operator
 - 4.4. Concrete plant inspectors
 - 4.5. Personnel performing saw cutting and joint sealing
 - 4.6. Paving machine operators
 - 4.7. Inspectors
 - 4.8. Samplers
 - 4.9. Testers

The purpose of the prepaving conference is to familiarize personnel with the project's specifications. Discuss the QC plan and processes for constructing each item of work, including:

1. Production
2. Transportation
3. Trial slabs
4. Pavement structure removal
5. Placement
6. Contingency plan
7. Sampling
8. Testing
9. Acceptance

Do not start trial slabs or paving activities until the listed personnel have attended the prepaving conference.

41-9.01D(5) Trial Slabs

Before starting individual slab replacement work, complete 1 trial slab for each mix design.

Place trial slabs near the job site at a mutually-agreed location that is neither on the roadway nor within the project limits. Trial slabs must be 10 by 20 feet and at least 10 inches thick.

During trial slab construction, sample and split the aggregate for grading, cleanness value, and sand equivalent testing.

Fabricate and test beams under California Test 524 to determine the modulus of rupture values.

Cure beams fabricated for early age testing such that the monitored temperatures in the beams and the slab are always within 5 degrees F of each other.

Monitor and record the internal temperatures of trial slabs and early age beams at intervals of at least 5 minutes. Install thermocouples or thermistors connected to strip-chart recorders or digital data loggers to monitor the temperatures. Temperature recording devices must be accurate to within 2 degrees F.

Measure internal temperatures at 1 inch from the top, 1 inch from the bottom, and no closer than 3 inches from any edge until early age testing is completed.

Cure beams fabricated for 3-day testing under California Test 524 except place them into sand at a time that is from 5 to 10 times the time of final setting measured under ASTM C403/403M or 24 hours, whichever is earlier.

Trial slabs must have an opening age modulus of rupture of not less than 400 psi and a 3-day modulus of rupture of not less than 600 psi.

After authorization, remove and dispose of trial slabs and testing materials.

41-9.01D(6) Quality Control Testing

41-9.01D(6)(a) General

Provide continuous process control and quality control sampling and testing throughout RSC production and placement. Notify the Engineer at least 2 business days notice before any sampling and testing. Establish a testing facility at the job site or at an authorized location.

Sample under California Test 125.

During ISR—RSC placement, sample and fabricate beams for modulus of rupture testing within the first 30 cubic yards, at least once every 130 cu yd, and within the final truckload. Submit split samples and fabricate test beams for the Department's testing unless the Engineer informs you otherwise.

Determine the modulus of rupture at opening age under California Test 524, except beam specimens may be fabricated using an internal vibrator under ASTM C 31. Cure beams under the same conditions as the pavement until 1 hour before testing. Test 3 beam specimens in the presence of the Engineer and average the results. A single test represents no more than that day's production or 130 cu yd, whichever is less.

Determine the modulus of rupture at other ages using beams cured and tested under California Test 524 except place them in sand from 5 to 10 times the time of final setting under ASTM C403/C403M or 24 hours, whichever is earlier.

41-9.01D(6)(b) Rapid Strength Concrete

Your quality control must include testing RSC for the properties at the frequencies shown in the following table:

RSC Minimum Quality Control

Property	Test method	Minimum testing frequency ^a
Cleanness value	California Test 227	650 cu yd or 1 per shift
Sand equivalent	California Test 217	650 cu yd or 1 per shift
Aggregate gradation	California Test 202	650 cu yd or 1 per shift
Air content	California Test 504	130 cu yd or 2 per shift
Yield	California Test 518	2 per shift
Slump or penetration	ASTM C143 or California Test 533	1 per 2 hours of paving
Unit weight	California Test 518	650 cubic yards or 2 per shift
Aggregate Moisture Meter Calibration ^b	California Test 223 or California Test 226	1 per shift
Modulus of rupture	California Test 524	Comply with section 41-9.01D(6)(a)

^aTest at the most frequent interval.

^bCheck calibration of the plant moisture meter by comparing moisture meter readings with California Test 223 or California Test 226 test results

Maintain control charts to identify potential problems and causes. Post a copy of each control chart at a location determined by the Engineer.

Individual measurement control charts must use the target values in the mix proportions as indicators of central tendency.

Develop linear control charts for:

1. Cleanness value
2. Sand equivalent
3. Fine and coarse aggregate gradation
4. Air content
5. Penetration

Control charts must include:

1. Contract number
2. Mix proportions
3. Test number
4. Each test parameter
5. Action and suspension limits
6. Specification limits
7. Quality control test results

For fine and coarse aggregate gradation control charts, record the running average of the previous 4 consecutive gradation tests for each sieve and superimpose the specification limits.

For air content control charts, the action limit is ± 1.0 percent and the suspension limit is ± 1.5 percent of the specified values. If no value is specified, apply the air content value used in the approved mix design.

As a minimum, a process is out of control if any of the following occurs:

1. For fine and coarse aggregate gradation, 2 consecutive running averages of 4 tests are outside the specification limits
2. For individual penetration or air content measurements:
 - 2.1. One point falls outside the suspension limit line
 - 2.2. Two points in a row fall outside the action limit line

Stop production and take corrective action for out of control processes or the Engineer rejects subsequent RSC.

Before each day's concrete pavement placement and at intervals not to exceed 4 hours of production, use a tachometer to test and record vibration frequency for concrete consolidation vibrators.

41-9.01D(6)(c) Reserved

41-9.01D(7) Acceptance Criteria

41-9.01D(7)(a) General

The final texture of ISR—RSC must pass visual inspection and have a coefficient of friction of at least 0.30 determined under California Test 342.

Allow at least 25 days for the Department to schedule testing for coefficient of friction. Notify the Engineer when the pavement is scheduled to be opened to traffic.

41-9.01D(7)(b) Modulus of Rupture

ISR—RSC is accepted based on your testing for modulus of rupture at opening age and the Department's testing for modulus of rupture at 3 days.

ISR—RSC must have a modulus of rupture at opening age that is at least 400 psi and a modulus of rupture at 3 days that is at least 600 psi.

Calculate the test result as the average from testing 3 beams for each sample. The test result represents 1 paving shift or 130 cu yd, whichever is less.

41-9.01D(7)(c) Concrete Pavement Smoothness

The Department tests for concrete pavement smoothness using a 12-foot straightedge. Straightedge smoothness specifications do not apply to the pavement surface placed within 12 inches of existing concrete pavement except parallel to the centerline at the midpoint of a transverse construction joint.

The concrete pavement surface must not vary from the lower edge of a 12-foot straightedge by more than:

1. 0.01 feet when parallel to the centerline
2. 0.02 feet when perpendicular to the centerline extending from edge to edge of a traffic lane

41-9.01D(7)(d) Cracking and Raveling

The Engineer rejects an ISR—RSC slab under section 6-3.06 if within 1 year of contract acceptance there is either:

1. Partial or full-depth cracking
2. Concrete raveling consisting of either:
 - 2.1. Combined raveled areas more than 5 percent of each ISR—RSC slab area
 - 2.2. Any single raveled area of more than 4 sq ft

41-9.01D(8) Reserved

41-9.02 MATERIALS

41-9.02A General

Reserved

41-9.02B Rapid Strength Concrete

RSC for ISR—RSC must comply with section 90-3.

Use either the 1-1/2 inch maximum or the 1-inch maximum combined grading specified in section 90-1.02C(4)(d).

Air content must comply with the minimum requirements in section 40-1.02B(4).

41-9.02C Base Bond Breaker

Use base bond breaker no. 3, 4, or 5 under section 36-2.

41-9.02D Reserved

41-9.03 CONSTRUCTION

41-9.03A General

Complete ISR—RSC adjacent to new pavement or existing pavement shown for construction as a 1st order of work. Replace individual slabs damaged during construction before placing final pavement delineation.

41-9.03B Removing Existing Pavement

Remove pavement under section 15-2.02. The Engineer determines the exact ISR—RSC limits after overlying layers are removed.

After removing pavement to the depth shown, grade to a uniform plane. Water as needed and compact the material remaining in place to a firm and stable base. The finished surface of the remaining material must not extend above the grade established by the Engineer.

41-9.03C Drill and Bond Dowel Bars

Drill existing concrete and bond dowel bars under section 41-10 if described. Do not install dowel bars in contraction joints.

41-9.03D Base Bond Breaker

Place base bond breaker before placing ISR—RSC. Comply with section 36-2.

41-9.03E Placing Rapid Strength Concrete

Do not place RSC if the ambient air temperature is forecast by the National Weather Service to be less than 40 degrees F within 72 hours of final finishing.

Before placing RSC against existing concrete, place 1/4-inch thick commercial quality polyethylene flexible foam expansion joint filler across the original transverse and longitudinal joint faces and extend the full depth of pavement to the top of the base layer. Place the top of the joint filler flush with the top of

the pavement. Secure joint filler to the joint face of the existing pavement to prevent the joint filler from moving during the placement of RSC.

Use metal or wood side forms. Wood side forms must not be less than 1-1/2 inches thick. Side forms and connections must be of sufficient rigidity that movement will not occur under forces from equipment or RSC. Clean and oil side forms before each use. Side forms must remain in place until the pavement edge no longer requires the protection of forms.

After you place RSC, consolidate it using high-frequency internal vibrators adjacent to forms and across the full paving width. Place RSC as nearly as possible to its final position. Do not use vibrators for extensive shifting of concrete pavement.

Spread and shape RSC with powered finishing machines supplemented by hand finishing. After you mix and place RSC, do not add water to the surface to facilitate finishing. You may request authorization to use surface finishing additives. Submit the manufacturer's instructions with your request.

Place consecutive concrete loads without interruption. Do not allow cold joints where a visible lineation forms after concrete is placed, sets, and hardens before additional concrete placed.

Where the existing transverse joint spacing in an adjacent lane exceeds 15 feet, construct an additional transverse contraction joint midway between the existing joints. Complete sawing of contraction joints within 2 hours of completion of final finishing.

Cut contraction joints a minimum of 1/3 the slab depth.

41-9.03F Final Finishing

After preliminary finishing, round the edges of the initial paving width to a 0.04-foot radius. Round transverse and longitudinal construction joints to a 0.02-foot radius. Mark each ISR—RSC area with a stamp. The stamp mark must show the month, day, and year of placement and contract number. Level the location of the stamp with a steel trowel below the pavement texture. Orient the stamp mark so it can be read from the outside edge of ISR—RSC.

Before curing, texture the pavement. Perform initial texturing with a burlap drag or broom device that produces striations parallel to the centerline. Perform final texturing with a steel-tined device that produces grooves parallel with the centerline.

Tines must be from 3/32 to 1/8 inch wide on 3/4-inch centers and have enough length, thickness, and resilience to form grooves from 1/8 to 3/16 inch deep after the concrete has hardened. Grooves must extend over the entire pavement width except do not construct grooves 3 inches from longitudinal pavement edges or joints.

Final texture must be uniform and smooth. Grooves must be parallel and aligned to the pavement edge across the pavement width. The groove alignment must not vary more than 0.1 foot for every 12 foot length.

Protect RSC under section 90-1.03C.

41-9.03G Temporary Pavement Structure

Temporary pavement structure must be RSC or 3-1/2 inch thick HMA over aggregate base.

41-9.03H Noncompliant Individual Slab Replacement

Replace an ISR—RSC slab with any of the following:

1. One or more full-depth cracks.
2. Concrete raveling.
3. Noncompliant smoothness except you may request authorization for grinding under section 42 and retesting. Grinding that causes a depression will not be considered. Smoothness must be corrected within 48 hours of placing ISR—RSC.
4. Noncompliant modulus of rupture.

If the modulus of rupture at opening age is at least 400 psi and the modulus of rupture at 3 days is at least 500 psi but less than 600 psi, you may request authorization to leave the ISR—RSC in place and accept the specified deduction.

If pavement is noncompliant for coefficient of friction, groove or grind the pavement under section 42. Comply with section 40-1.03Q(4) and groove or grind before the installation of any required joint seal or edge drains adjacent to the areas to the noncompliant area.

If an ISR—RSC slab has partial depth cracking, treat it with high-molecular-weight methacrylate under section 41-3.

41-9.03I Replace Pavement Delineation

Replace traffic stripes, pavement markings, and markers that are removed, obliterated, or damaged by ISR—RSC under sections 84 and 85.

41-9.03J Reserved

41-9.04 PAYMENT

Replace base is not included in the payment for individual slab replacement (RSC).

Drill and bond dowel bars are not included in payment for individual slab replacement (RSC).

For individual slab replacement (RSC) with a modulus of rupture at opening age that is at least 400 psi and a modulus of rupture at 3 days that is greater than or equal to 500 psi but less than 550 psi, the Department deducts 10 percent of the payment for individual slab replacement (RSC).

For individual slab replacement (RSC) with a modulus of rupture at opening age that is at least 400 psi and a modulus of rupture at 3 days that is greater than or equal to 550 psi but less than 600 psi, the Department deducts 5 percent of the payment for individual slab replacement (RSC).

41-10 DRILL AND BOND BARS

41-10.01 GENERAL

41-10.01A Summary

Section 41-10 includes specifications for drilling, installing, and bonding tie bars and dowel bars in concrete pavement.

41-10.01B Definitions

Reserved

41-10.01C Submittals

Submit a certificate of compliance for:

1. Tie bars
2. Dowel bars
3. Dowel bar lubricant
4. Chemical adhesive
5. Epoxy powder coating

At least 15 days before delivery to the job site, submit the manufacturer's recommendations and instructions for storage, handling, and use of chemical adhesive.

41-10.01D Quality Control and Assurance

41-10.01D(1) General

Drill and bond bar is accepted based on inspection before concrete placement.

41-10.01D(2) Reserved

41-10.02 MATERIALS

41-10.02A General

Dowel bar lubricant must comply with section 40-1.02D.

Chemical adhesive for drilling and bonding bars must be on the Authorized Material List. The Authorized Material List indicates the appropriate chemical adhesive system for concrete temperature and installation conditions.

Each chemical adhesive system container must clearly and permanently show the following:

1. Manufacturer's name
2. Model number of the system
3. Manufacture date
4. Batch number
5. Expiration date
6. Current International Conference of Building Officials Evaluation Report number
7. Directions for use
8. Storage requirement
9. Warnings or precautions required by state and federal laws and regulations

41-10.02B Reserved

41-10.03 CONSTRUCTION

41-10.03A General

Drill holes for bars. Clean drilled holes in compliance with the chemical adhesive manufacturer's instructions. Holes must be dry at the time of placing the chemical adhesive and bars. Use a grout retention ring when drilling and bonding dowel bars. Immediately after inserting the bar into the chemical adhesive, support the bar to prevent movement until chemical adhesive has cured the minimum time recommended by the manufacturer.

Apply dowel bar lubricant to the entire exposed portion of the dowel bar.

If the Engineer rejects a bar installation: stop paving, drilling, and bonding activities. Adjust your procedures and obtain the Engineer's verbal authorization before resuming paving, drilling, and bonding.

Cut the rejected bar flush with the pavement joint surface and coat the exposed end of the bar with chemical adhesive. Offset the new hole 3 inches horizontally from the rejected hole's center.

41-10.03B Tie Bar Tolerance

Place tie bars within the tolerances shown in the following table:

Tie Bar Tolerances

Dimension	Tolerance
Horizontal skew (vertical skew: bar length)	1:6
Vertical skew (vertical skew: bar length)	1:6
Longitudinal translation (inch)	±1
Horizontal offset (embedment, inch)	±1
Height relative to the adjacent bar	±1
Vertical Depth (clearance from the pavement surface or bottom, inches, min)	3

41-10.03C Dowel Bar Tolerance

Place dowel bars within the tolerances specified in section 40-1.01D(7)(b)(v).

41-10.03D Reserved

41-10.04 PAYMENT

Not Used

41-11–41-15 RESERVED

^ ^

42 GROOVE AND GRIND CONCRETE

07-19-13

Replace the paragraph of section 42-1.01A with:

07-19-13

Section 42-1 includes general specifications for grooving and grinding concrete.

Replace the headings and paragraphs in section 42-3 with:

07-19-13

42-3.01 GENERAL

42-3.01A Summary

Section 42-3 includes specifications for grinding the surfaces of pavement, bridge decks, and approach slabs.

42-3.01B Definitions

Reserved

42-3.01C Submittals

Reserved

42-3.01D Quality Control and Assurance

Reserved

42-3.02 MATERIALS

Not Used

42-3.03 CONSTRUCTION

42-3.03A General

Grind surfaces in the longitudinal direction of the traveled way and grind the full lane width. Begin and end grinding at lines perpendicular to the roadway centerline.

Grinding must result in a parallel corduroy texture with grooves from 0.08 to 0.12 inch wide and from 55 to 60 grooves per foot of width. Grooves must be from 0.06 to 0.08 inch from the top of the ridge to the bottom of the groove.

Grind with abrasive grinding equipment using diamond cutting blades mounted on a self-propelled machine designed for grinding and texturing concrete pavements.

42-3.03B Pavement

Grind existing concrete pavement that is adjacent to an individual slab replacement. Grind the replaced individual slab and all the existing slabs immediately surrounding it. Grind after the individual slab is replaced.

Grind existing concrete pavement that is adjacent to new lanes of concrete pavement. Grind before paving.

After grinding, the existing pavement must comply with requirements for smoothness and coefficient of friction in section 40 except:

1. At the midpoint of a joint or crack, test smoothness with a straightedge. Both sides must have uniform texture.
2. Straightedge and inertial profiler requirements do not apply to areas abnormally depressed from subsidence or other localized causes. End smoothness testing 15 feet before and resume 15 feet after these areas.
3. Cross-slope must be uniform and have positive drainage across the traveled way and shoulder.

As an alternative to grinding existing concrete pavement, you may replace the existing pavement. The new concrete pavement must be the same thickness as the removed pavement. Replace existing pavement between longitudinal joints or pavement edges and transverse joints. Do not remove portions of slabs.

Replacement of existing concrete pavement must comply with requirements for individual slab replacement in section 41-9.

42-3.03C Bridge Decks, Approach Slabs, and Approach Pavement

Grind bridge decks, approach slabs, and approach pavement only if described.

The following ground areas must comply with the specifications for smoothness and concrete cover over reinforcing steel in section 51-1.01D(4):

1. Bridge decks
2. Approach slabs
3. Adjacent 50 feet of approach pavement

After grinding, the coefficient of friction must comply with section 51-1.01D(4).

Replace the 4th paragraph of section 46-1.01D(2)(b) with:

01-18-13

Each jack and its gage must be calibrated as a unit under the specifications for jacks used to tension prestressing steel permanently anchored at 25 percent or more of its specified minimum ultimate tensile strength in section 50-1.01D(3).

Replace the 3rd paragraph of section 46-1.01D(2)(d) with:

07-19-13

The Department may verify the test loads using the Department's load cells. If requested, install and support the Department's testing equipment during testing and remove the equipment after testing is complete.

Add to section 46-1.02:

07-19-13

46-1.02C Grout

Grout must consist of cement and water and may contain an admixture if authorized. Cement must comply with section 90-1.02B(2). Water must comply with section 90-1.02D. Admixtures must comply with section 90, except they must not contain chloride ions in excess of 0.25 percent by weight. Do not exceed 5 gallons of water per 94 lb of cement.

Mix the grout as follows:

1. Add water to the mixer followed by cement and any admixtures or fine aggregate.
2. Mix the grout with mechanical mixing equipment that produces a uniform and thoroughly mixed grout.
3. Agitate the grout continuously until the grout is pumped.
4. Do not add water after the initial mixing.

Add to section 46-1.03B:

04-20-12

Dispose of drill cuttings under section 19-2.03B.

Add to the end of section 46-1.03C:

07-19-13

Grouting equipment must be:

1. Capable of grouting at a pressure of at least 100 psi
2. Equipped with a pressure gage having a full-scale reading of not more than 300 psi

07-19-13

Delete the 3rd paragraph of section 46-2.01A.

Add to the beginning of section 46-2.01C:

07-19-13

Submittals for strand tendons, bar tendons, bar couplers, and anchorage assemblies must comply with section 50-1.01C.

Add to section 46-2.01D:

07-19-13

46-2.01D(3) Steel

Strand tendons, bar tendons, bar couplers, and anchorage assemblies must comply with section 50-1.01D.

46-2.01D(4) Grout

The Department tests the efflux time of the grout under California Test 541.

Add to the beginning of section 46-2.02B:

07-19-13

Strand tendons, bar tendons, and bar couplers must comply with section 50-1.02B.

Replace the 1st paragraph of section 46-2.02E with:

07-19-13

The efflux time of the grout immediately after mixing must be at least 11 seconds.

Add between the 13th and 14th paragraphs of section 46-2.03A:

07-19-13

If hot weather conditions will contribute to quick stiffening of the grout, cool the grout by authorized methods as necessary to prevent blockages during pumping activities.

Add between the 1st and 2nd paragraphs of section 46-2.03D:

07-19-13

Secure the ends of strand tendons with a permanent type anchorage system that:

1. Holds the prestressing steel at a force producing a stress of at least 95 percent of the specified ultimate tensile strength of the steel
2. Permanently secures the ends of the prestressing steel

Replace the 2nd sentence of the 1st paragraph of section 46-3.02A with:

07-19-13

The epoxy-coated prefabricated reinforcing bar must comply with section 52-2.03, except the epoxy thickness must be from 10 to 12 mils.

Reinforcement must comply with section 52.

Concrete crib walls consist of a series of rectangular cells composed of interlocking, precast, reinforced concrete headers, stretchers, and blocks.

47-3.02 Materials

47-3.02A General

Pads shown to be placed between bearing surfaces must either be (1) neoprene complying with the specifications for strip waterstops in section 51-2.05 or (2) commercial quality no. 30 asphalt felt. The protective board is not required for neoprene pads.

47-3.02B Crib Members

47-3.02B(1) General

All members may be manufactured to dimensions 1/8 inch greater in thickness than shown. The thickness of the lowest step must not be less than the dimension shown.

Stretchers may be manufactured 1/2 inch less in length than shown.

When an opening is shown in the face of the wall, special length stretchers and additional headers may be necessary.

For non-tangent wall alignments, special length stretchers may be required.

For non-tangent wall alignments and at locations where filler blocks are required, special length front face closure members may be required.

47-3.02B(2) Reinforcement

Reinforcing wire must comply with ASTM A 496/A 496M.

For hoops or stirrups use either (1) reinforcing wire or (2) deformed steel welded wire reinforcement. The size must be equivalent to the reinforcing steel shown. Deformed steel welded wire reinforcement must comply with ASTM A 497/A 497M.

47-3.02B(3) Concrete

Concrete test cylinders must comply with section 90-1.01D(5), except when the penetration of fresh concrete is less than 1 inch, the concrete in the test mold must be consolidated by vibrating the mold equivalent to the consolidating effort being used to consolidate the concrete in the members.

Cure crib members under section 51-4.02C.

When removed from forms, the members must present a true surface of even texture, free from honeycombs and voids larger than 1 inch in diameter and 5/16 inch in depth. Clean and fill other pockets with mortar under sections 51-1.02F and 51-1.03E(2).

External vibration resulting in adequate consolidation may be used.

If the Engineer determines that rock pockets are of the extent or character as to affect the strength of the member or to endanger the life of the steel reinforcement, replace the member.

Finish concrete-to-concrete bearing surfaces to a smooth plane. Section 51-1.03F does not apply to concrete crib members.

47-3.03 Construction

Place reinforced concrete crib walls to the lines and grades established by the Engineer. The foundation must be accepted by the Engineer before any crib members are placed.

The gap between bearing surfaces must not exceed 1/8 inch.

Where a gap of 1/16 inch to 1/8 inch exists or where shown, place a 1/16-inch pad of asphalt felt or sheet neoprene between the bearing surfaces.

47-3.04 Payment

The area of reinforced concrete crib wall is measured on the batter at the outer face for the height from the bottom of the bottom stretcher to the top of the top stretcher and for a length measured from end to end of each section of wall.

Add between the 3rd and 4th paragraphs of section 47-5.01:

10-19-12

Reinforcement must comply with section 52.

Add to section 47-6.01A:

10-19-12

The alternative earth retaining system must comply with the specifications for the type of wall being constructed.

Replace "sets" at each occurrence in the 1st paragraph of section 47-6.01C with:

04-19-13

copies

AA

48 TEMPORARY STRUCTURES

07-19-13

Replace "previously welded splice" and its definition in section 48-2.01B with:

04-19-13

previously welded splice: Splice made in a falsework member in compliance with AWS D1.1 or other recognized welding standard before contract award.

Add to section 48-2.01B:

07-19-13

independent support system: Support system that is in addition to the falsework removal system employing methods of holding falsework from above by winches, hydraulic jacks with prestressing steel, HS rods, or cranes.

04-19-13

Delete "field" in the 1st sentence of the 5th paragraph of section 48-2.01C(1).

Replace item 1 in the list in the 6th paragraph of section 48-2.01C(1) with:

04-19-13

- 1. Itemize the testing, inspection methods, and acceptance criteria used

Replace "sets" at each occurrence in the 4th paragraph of section 48-2.01C(2) with:

07-19-13

copies

Replace the 7th paragraph of section 48-2.01C(2) with:

09-16-11

If you submit multiple submittals at the same time or additional submittals before review of a previous submittal is complete:

1. You must designate a review sequence for submittals
2. Review time for any submittal is the review time specified plus 15 days for each submittal of higher priority still under review

Add to section 48-2.01C(2):

07-19-13

Shop drawings and calculations for falsework removal systems employing methods of holding falsework from above by winches, hydraulic jacks with prestressing steel, HS rods, or cranes must include:

1. Design code used for the analysis of the structural members of the independent support system
2. Provisions for complying with current Cal/OSHA requirements
3. Load tests and ratings within 1 year of intended use of hydraulic jacks and winches
4. Location of the winches, hydraulic jacks with prestressing steel, HS rods, or cranes
5. Analysis showing that the bridge deck and overhang are capable of supporting all loads at all time
6. Analysis showing that winches will not overturn or slide during all stages of loading
7. Location of deck and soffit openings if needed
8. Details of repair for the deck and soffit openings after falsework removal

Replace the 1st paragraph of section 48-2.01D(2) with:

04-19-13

Welding must comply with AWS D1.1 or other recognized welding standard, except for fillet welds where the load demands are 1,000 lb or less per inch for each 1/8 inch of fillet weld.

Replace the 1st through 3rd sentences in the 2nd paragraph of section 48-2.01D(2) with:

04-19-13

Perform NDT on welded splices using UT or RT. Each weld and any repair made to a previously welded splice must be tested.

Replace the 3rd paragraph of section 48-2.01D(2) with:

04-19-13

For previously welded splices, perform and document all necessary testing and inspection required to certify the ability of the falsework members to sustain the design stresses.

Add to section 49-1.03:

04-20-12

Dispose of drill cuttings under section 19-2.03B.

Replace the paragraph of section 49-2.01A(1) with:

07-19-13

Section 49-2.01 includes general specifications for fabricating and installing driven piles.
Epoxy-coated bar reinforcing steel used for pile anchors must comply with section 52-2.02.

Replace the 2nd paragraph of section 49-2.01D with:

01-20-12

Furnish piling is measured along the longest side of the pile from the specified tip elevation shown to the plane of pile cutoff.

Replace the paragraph of section 49-2.02A(1) with:

07-19-13

Section 49-2.02 includes specifications for fabricating and installing steel pipe piles.

Replace the definitions in section 49-2.02A(2) with:

07-19-13

shop welding: Welding performed at a plant on the Department's Authorized Facility Audit List.
field welding: Welding not performed at a plant on the Department's Authorized Facility Audit List.

Replace item 2 in the list in the paragraph of section 49-2.02A(3)(b) with:

07-19-13

2. Certified mill test reports for each heat number of steel used in pipe piles being furnished.

Replace the paragraph of section 49-2.02A(4)(a) with:

07-19-13

Section 11-3.02 does not apply to shop welds in steel pipe piles fabricated at a facility on the Department's Authorized Facility Audit List.
For groove welds using submerged arc welding from both sides without backgouging, qualify the WPS under Table 4.5 of AWS D1.1.

Replace "0.45" in the 2nd paragraph of section 49-2.02B(1)(a) with:

07-19-13

0.47

Replace the 1st paragraph of section 49-2.02B(1)(b) with:

07-19-13

Welds must comply with AWS D1.1. Circumferential welds must be CJP welds.

07-19-13

Delete the 5th paragraph of section 49-2.02B(1)(b).

Add to section 49-2.02B(1):

07-19-13

49-2.02B(1)(d) Reserved

Replace "4.8.4" in item 2.3 in the list in the 2nd paragraph of section 49-2.02B(2) with:

07-19-13

4.9.4

07-19-13

Delete the 3rd paragraph of section 49-2.02C(2).

Replace the paragraph of section 49-2.03A(1) with:

07-19-13

Section 49-2.03 includes specifications for fabricating and installing structural shape steel piles.

Replace the paragraph of section 49-2.03A(3) with:

07-19-13

Submit a certified material test report and a certificate of compliance that includes a statement that all materials and workmanship incorporated in the work and all required tests and inspections of this work have been performed as described.

Replace the 1st paragraph of section 49-2.03B with:

07-19-13

Structural shape steel piles must comply with ASTM A 36/A 36M, ASTM A 572/A 572M, ASTM A 709/A 709M, or ASTM A 992/A 992M.

Replace "sets" in the 1st paragraph of section 49-2.04A(3) with:

04-19-13

copies

07-19-13

Delete the 1st paragraph of section 49-2.04A(4).

Replace the 3rd and 4th paragraphs of section 49-2.04B(2) with:

10-19-12

Piles in a corrosive environment must be steam or water cured under section 90-4.03.

If piles in a corrosive environment are steam cured, either:

1. Keep the piles continuously wet for at least 3 days. The 3 days includes the holding and steam curing periods.
2. Apply curing compound under section 90-1.03B(3) after steam curing.

Replace the 1st paragraph of section 49-3.01A with:

07-19-13

Section 49-3.01 includes general specifications for constructing CIP concrete piles.

Add to section 49-3.01A:

01-20-12

Concrete must comply with section 51.

Replace the 1st paragraph of section 49-3.01C with:

01-20-12

Except for CIDH concrete piles constructed under slurry, construct CIP concrete piles such that the excavation methods and the concrete placement procedures provide for placing the concrete against undisturbed material in a dry or dewatered hole.

Replace "Reserved" in section 49-3.02A(2) with:

01-20-12

dry hole:

1. Except for CIDH concrete piles specified as end bearing, a drilled hole that:
 - 1.1. Accumulates no more than 12 inches of water in the bottom of the drilled hole during a period of 1 hour without any pumping from the hole during the hour.
 - 1.2. Has no more than 3 inches of water in the bottom of the drilled hole immediately before placing concrete.
2. For CIDH concrete piles specified as end bearing, a drilled hole free of water without the use of pumps.

Replace "Reserved" in section 49-3.02A(3)(a) with:

01-20-12

If plastic spacers are proposed for use, submit the manufacturer's data and a sample of the plastic spacer. Allow 10 days for review.

Replace item 5 in the list in the 1st paragraph of section 49-3.02A(3)(b) with:

10-19-12

5. Methods and equipment for determining:
 - 5.1. Depth of concrete
 - 5.2. Theoretical volume of concrete to be placed, including the effects on volume if casings are withdrawn
 - 5.3. Actual volume of concrete placed

Add to the list in the 1st paragraph of section 49-3.02A(3)(b):

01-18-13

8. Drilling sequence and concrete placement plan.

Replace item 2 in the list in the 1st paragraph of section 49-3.02A(3)(g) with:

01-20-12

2. Be sealed and signed by an engineer who is registered as a civil engineer in the State. This requirement is waived for either of the following conditions:
 - 2.1. The proposed mitigation will be performed under the current Department-published version of *ADSC Standard Mitigation Plan 'A' - Basic Repair* without exception or modification.
 - 2.2. The Engineer determines that the rejected pile does not require mitigation due to structural, geotechnical, or corrosion concerns, and you elect to repair the pile using the current Department-published version of *ADSC Standard Mitigation Plan 'B' - Grouting Repair* without exception or modification.

Replace "49-2.03A(4)(d)" in the 1st paragraph of section 49-3.02A(4)(d)(i) with:

07-19-13

49-3.02A(4)(d)

Add to the beginning of section 49-3.02A(4)(d)(ii):

07-19-13

If the drilled hole is dry or dewatered without the use of temporary casing to control ground water, installation of inspection pipes is not required.

Replace item 1 in the list in the 1st paragraph of section 49-3.02A(4)(d)(ii) with:

01-20-12

1. Inspection pipes must be schedule 40 PVC pipe complying with ASTM D 1785 with a nominal pipe size of 2 inches. Watertight PVC couplers complying with ASTM D 2466 are allowed to facilitate pipe lengths in excess of those commercially available. Log the location of the inspection pipe couplers with respect to the plane of pile cutoff.

Add to section 49-3.02A(4)(d)(iv):

01-20-12

If the Engineer determines it is not feasible to use one of ADSC's standard mitigation plans to mitigate the pile, schedule a meeting and meet with the Engineer before submitting a nonstandard mitigation plan.

The meeting attendees must include your representatives and the Engineer's representatives involved in the pile mitigation. The purpose of the meeting is to discuss the type of pile mitigation acceptable to the Department.

Provide the meeting facility. The Engineer conducts the meeting.

Replace the 1st paragraph of section 49-3.02B(5) with:

07-19-13

Grout must consist of cementitious material and water, and may contain an admixture if authorized. Do not exceed 5 gallons of water per 94 lb of cement.

Cementitious material must comply with section 90-1.02B, except SCMs are not required.

Water must comply with section 90-1.02D. If municipally supplied potable water is used, the testing specified in section 90-1.02D is waived.

Admixtures must comply with section 90, except admixtures must not contain chloride ions in excess of 0.25 percent by weight.

Use aggregate to extend the grout as follows:

1. Aggregate must consist of at least 70 percent fine aggregate and approximately 30 percent pea gravel, by weight.
2. Fine aggregate must comply with section 90-1.02C(3).
3. Size of pea gravel must be such that 100 percent passes the 1/2-inch sieve, at least 85 percent passes the 3/8-inch sieve, and not more than 5 percent passes the no. 8 sieve.
4. Minimum cementitious material content of the grout must not be less than 845 lb/cu yd of grout.

Mix the grout as follows:

1. Add water to the mixer followed by cementitious material, aggregates, and any admixtures.
2. Mix the grout with mechanical mixing equipment that produces a uniform and thoroughly mixed grout.
3. Agitate the grout continuously until the grout is pumped.
4. Do not add water after initial mixing.

Replace section 49-3.02B(8) with:

01-20-12

49-3.02B(8) Spacers

Spacers must comply with section 52-1.03D, except you may use plastic spacers.

Plastic spacers must:

1. Comply with sections 3.4 and 3.5 of the Concrete Reinforcing Steel Institute's *Manual of Standard Practice*

2. Have at least 25 percent of their gross plane area perforated to compensate for the difference in the coefficient of thermal expansion between the plastic and concrete
3. Be of commercial quality

Add between the 1st and 2nd paragraphs of section 49-3.02C(2):

07-19-13

For CIDH concrete piles with a pile cap, the horizontal tolerance at the center of each pile at pile cut-off is the larger of 1/24 of the pile diameter or 3 inches. The horizontal tolerance for the center-to-center spacing of 2 adjacent piles is the larger of 1/24 of the pile diameter or 3 inches.

Add between the 3rd and 4th paragraphs of section 49-3.02C(2):

07-18-14

If drilling slurry is used during excavation, maintain the slurry level at least 10 feet above the piezometric head.

Add to section 49-3.02C(4):

01-20-12

Unless otherwise shown, the bar reinforcing steel cage must have at least 3 inches of clear cover measured from the outside of the cage to the sides of the hole or casing.

Place spacers at least 5 inches clear from any inspection tubes.

Place plastic spacers around the circumference of the cage and at intervals along the length of the cage, as recommended by the manufacturer.

07-19-13

For a single CIDH concrete pile supporting a column:

1. If the pile and the column share the same reinforcing cage diameter, this cage must be accurately placed as shown
2. If the pile reinforcing cage is larger than the column cage and the concrete is placed under dry conditions, maintain a clear horizontal distance of at least 3.5 inches between the two cages
3. If the pile reinforcing cage is larger than the column cage and the concrete is placed under slurry, maintain a clear horizontal distance of at least 5 inches between the two cages

Replace section 49-3.02C(6) with:

07-19-13

49-3.02C(6) Construction Joint

Section 49-3.02C(6) applies to CIDH concrete piles where a construction joint is shown.

If a permanent steel casing is not shown, you must furnish and install a permanent casing. The permanent casing must:

1. Be watertight and of sufficient strength to prevent damage and to withstand the loads from installation procedures, drilling and tooling equipment, lateral concrete pressures, and earth pressures.

7. Theoretical grout volume calculations for each duct
8. Duct repair procedures due to an air pressure test failure
9. Mixing and pumping procedures
10. Direction of grouting
11. Sequence of use of inlets and outlets
12. Procedure for handling blockages
13. Proposed forms for recording grouting information
14. Procedure for secondary grouting
15. Names of people who will perform grouting activities including their relevant experience and certifications

Add to section 50-1.01C:

07-19-13

50-1.01C(5) Grout

Submit a daily grouting report for each day grouting is performed. Submit the report within 3 days after grouting. The report must be signed by the technician supervising the grouting activity. The report must include:

1. Identification of each tendon
2. Date grouting occurred
3. Time the grouting started and ended
4. Date of placing the prestressing steel in the ducts
5. Date of stressing
6. Type of grout used
7. Injection end and applied grouting pressure
8. Actual and theoretical quantity of grout used to fill duct
9. Ratio of actual to theoretical grout quantity
10. Records of air, grout, and structure surface temperatures during grouting.
11. Summary of tests performed and results, except submit compressive strength and chloride ion test results within 48 hours of test completion
12. Names of personnel performing the grouting activity
13. Summary of problems encountered and corrective actions taken
14. Summary of void investigations and repairs made

Replace the introductory clause in the 1st paragraph of section 50-1.01C(4) with:

07-19-13

Submit test samples for the materials shown in the following table to be used in the work:

Add between "the" and "test samples" in the 1st paragraph of section 50-1.01D(2):

07-19-13

prestressing steel

Replace the 3rd paragraph of section 50-1.01D(2) with:

10-19-12

The Department may verify the prestressing force using the Department's load cells.

Replace the 3rd paragraph in section 50-1.01D(3) with:

07-19-13

Each pressure gage must be fully functional and have an accurately reading, clearly visible dial or display. The dial must be at least 6 inches in diameter and graduated in 100 psi increments or less.

Add between the 5th and 6th paragraphs of section 50-1.01D(3):

07-19-13

Each jack and its gages must be calibrated as a unit.

Replace the 6th paragraph in section 50-1.01D(3) with:

07-19-13

Each jack used to tension prestressing steel permanently anchored at 25 percent or more of its specified minimum ultimate tensile strength must be calibrated by METS within 1 year of use and after each repair. You must:

1. Schedule the calibration of the jacking equipment with METS
2. Mechanically calibrate the gages with a dead weight tester or other authorized means before calibration of the jacking equipment by METS
3. Verify that the jack and supporting systems are complete, with proper components, and are in good operating condition
4. Provide labor, equipment, and material to (1) install and support the jacking and calibration equipment and (2) remove the equipment after the calibration is complete
5. Plot the calibration results

Each jack used to tension prestressing steel permanently anchored at less than 25 percent of its specified minimum ultimate tensile strength must be calibrated by an authorized laboratory within 6 months of use and after each repair.

Add to section 50-1.01D:

07-19-13

50-1.01D(4) Pressure Testing Ducts

For post-tensioned concrete bridges, pressure test each duct with compressed air after stressing. To pressure test the ducts:

1. Seal all inlets, outlets, and grout caps.

2. Open all inlets and outlets on adjacent ducts.
3. Attach an air compressor to an inlet at 1 end of the duct. The attachment must include a valve that separates the duct from the air source.
4. Attach a pressure gage to the inlet at the end of the duct.
5. Pressurize the duct to 50 psi.
6. Lock-off the air source.
7. Record the pressure loss after 1 minute.
8. If there is a pressure loss exceeding 25 psi, repair the leaks with authorized methods and retest.

Compressed air used to clear and test the ducts must be clean, dry, and free of oil or contaminants.

50-1.01D(5) Duct Demonstration of Post-Tensioned Members

Before placing forms for deck slabs of box girder bridges, demonstrate that any prestressing steel placed in the ducts is free and unbonded. If no prestressing steel is in the ducts, demonstrate that the ducts are unobstructed.

If prestressing steel is installed after the concrete is placed, demonstrate that the ducts are free of water and debris immediately before installing the steel.

Before post-tensioning any member, demonstrate that the prestressing steel is free and unbonded in the duct.

The Engineer must witness all demonstrations.

50-1.01D(6) Void Investigation

In the presence of the Engineer, investigate the ducts for voids between 24 hours and 72 hours after grouting completion. As a minimum, inspect the inlet and outlet ports at the anchorages and at high points in the tendons for voids after removal. Completely fill any voids found with secondary grout.

50-1.01D(7) Personnel Qualifications

Perform post-tensioning field activities, including grouting, under the direct supervision of a technician certified as a level 2 Bonded PT Field Specialist through the Post-Tensioning Institute. Grouting activities may be performed under the direct supervision of a technician certified as a Grouting Technician through the American Segmental Bridge Institute.

Replace the 6th paragraph of section 50-1.02B with:

07-19-13

Package the prestressing steel in containers or shipping forms that protect the steel against physical damage and corrosion during shipping and storage.

Replace the 13th paragraph of section 50-1.02B with:

07-19-13

Prestressing steel is rejected if surface rust either:

1. Cannot be removed by hand-cleaning with a fine steel wool pad
2. Leaves pits visible to the unaided eye after cleaning

Replace the 4th paragraph of section 50-1.02C with:

07-19-13

Admixtures must comply with section 90, except admixtures must not contain chloride ions in excess of 0.25 percent by weight.

07-19-13

Delete the 5th paragraphs of section 50-1.02C.

Add to section 50-1.02C:

07-19-13

Secondary grout must:

1. Comply with ASTM C 1107
2. Not have a deleterious effect on the steel, concrete, or bond strength of the steel to concrete

Replace item 9 including items 9.1 and 9.2 in the list in the 1st paragraph of section 50-1.02D with:

07-19-13

9. Have an inside cross-sectional area of at least 2.5 times the net area of the prestressing steel for multistrand tendons

Replace "3/8" in item 10 in the list in the 1st paragraph of section 50-1.02D with:

07-19-13

1/2

07-19-13

Delete the 2nd sentences in the 1st paragraph of section 50-1.02E.

Replace section 50-1.02F with:

07-19-13

50-1.02F Permanent Grout Caps

Permanent grout caps for anchorage systems of post-tensioned tendons must:

1. Be glass-fiber-reinforced plastic with antioxidant additives. The environmental stress-cracking failure time must be at least 192 hours under ASTM D 1693, Condition C.
2. Completely cover and seal the wedge plate or anchorage head and all exposed metal parts of the anchorage against the bearing plate using neoprene O-ring seals.
3. Have a grout vent at the top of the cap.
4. Be bolted to the anchorage with stainless steel complying with ASTM F 593, alloy 316. All fasteners, including nuts and washers, must be alloy 316.
5. Be pressure rated at or above 150 psi.

Add to section 50-1.02:

09-16-11

50-1.02G Sheathing

Sheathing for debonding prestressing strand must:

1. Be split or un-split flexible polymer plastic tubing
2. Have a minimum wall thickness of 0.025 inch
3. Have an inside diameter exceeding the maximum outside diameter of the strand by 0.025 to 0.14 inch

Split sheathing must overlap at least 3/8 inch.

Waterproofing tape used to seal the ends of the sheathing must be flexible adhesive tape.

The sheathing and waterproof tape must not react with the concrete, coating, or steel.

Replace the 2nd paragraph of section 50-1.03A(3) with:

07-19-13

After installation, cover the duct ends and vents to prevent water or debris from entering.

Add to section 50-1.03A(3):

07-19-13

Support ducts vertically and horizontally during concrete placement at a spacing of at most 4 feet.

07-19-13

Delete "at least" in the 1st paragraph of section 50-1.03B(1).

Add to section 50-1.03B(1):

01-20-12

After seating, the maximum tensile stress in the prestressing steel must not exceed 75 percent of the minimum ultimate tensile strength shown.

07-19-13

Delete the 1st through 4th paragraphs of section 50-1.03B(2)(a).

Replace "temporary tensile strength" in the 7th paragraph of section 50-1.03B(2)(a) with:

07-19-13

temporary tensile stress

Add to section 50-1.03B(2)(a):

07-19-13

If prestressing strand is installed using the push-through method, use guide caps at the front end of each strand to protect the duct from damage.

Add to the list in the 2nd paragraph of section 50-1.03B(2)(c):

07-19-13

3. Be equipped with permanent grout caps

Replace section 50-1.03B(2)(d) with:

07-19-13

50-1.03B(2)(d) Bonding and Grouting

50-1.03B(2)(d)(i) General

Bond the post-tensioned prestressing steel to the concrete by completely filling the entire void space between the duct and the prestressing steel with grout.

Ducts, vents, and grout caps must be clean and free from water and deleterious materials that would impair bonding of the grout or interfere with grouting procedures. Compressed air used for cleaning must be clean, dry, and free of oil or contaminants.

Prevent the leakage of grout through the anchorage assembly by positive mechanical means.

Before starting daily grouting activities, drain the pump system to remove any water from the piping system.

Break down and thoroughly clean the pump and piping system after each grouting session.

After completing duct grouting activities:

1. Abrasive blast clean and expose the aggregate of concrete surfaces where concrete is to be placed to cover and encase the anchorage assemblies
2. Remove the ends of vents 1 inch below the roadway surface

50-1.03B(2)(d)(ii) Mixing and Proportioning

Proportion solids by weight to an accuracy of 2 percent.

Proportion liquids by weight or volume to an accuracy of 1 percent.

Mix the grout as follows:

1. Add water to the mixer followed by the other ingredients.
2. Mix the grout with mechanical mixing equipment that produces a uniform and thoroughly mixed grout without an excessive temperature increase or loss of properties of the mixture.
3. Do not exceed 5 gal of water per 94 lb of cement or the quantity of water in the manufacturer's instructions, whichever is less.
4. Agitate the grout continuously until the grout is pumped. Do not add water after the initial mixing.

50-1.03B(2)(d)(iii) Placing

Pump grout into the duct within 30 minutes of the 1st addition of the mix components.

Inject grout from the lowest point of the duct in an uphill direction in 1 continuous operation maintaining a one-way flow of the grout. You may inject from the lowest anchorage if complete filling is ensured.

Before injecting grout, open all vents.

Continuously discharge grout from the vent to be closed. Do not close any vent until free water, visible slugs of grout, and entrapped air have been ejected and the consistency of the grout flowing from the vent is equivalent to the injected grout.

Pump the grout at a rate of 16 to 50 feet of duct per minute.

Conduct grouting at a pressure range of 10 to 50 psi measured at the grout inlet. Do not exceed maximum pumping pressure of 150 psi at the grout inlet.

As grout is injected, close the vents in sequence in the direction of flow starting with the closest vent.

Before closing the final vent at the grout cap, discharge at least 2 gal of grout into a clean receptacle.

Bleed all high point vents.

Lock a pressure of 5 psi into the duct by closing the grout inlet valve.

50-1.03B(2)(d)(iv) Weather Conditions

If hot weather conditions will contribute to quick stiffening of the grout, cool the grout by authorized methods as necessary to prevent blockages during pumping activities.

If freezing weather conditions are anticipated during and following the placement of grout, provide adequate means to protect the grout in the ducts from damage by freezing.

50-1.03B(2)(d)(v) Curing

During grouting and for a period of 24 hours after grouting, eliminate vibration from contractor controlled sources within 100 feet of the span in which grouting is taking place, including from moving vehicles, jackhammers, large compressors or generators, pile driving activities, soil compaction, and falsework removal. Do not vary loads on the span.

For PC concrete members, do not move or disturb the members after grouting for 24 hours. If ambient temperature drops below 50 degrees F, do not move or disturb the members for 48 hours.

Do not remove or open valves until grout has cured for at least 24 hours.

50-1.03B(2)(d)(vi) Grouting Equipment

Grouting equipment must be:

1. Capable of grouting at a pressure of at least 100 psi
2. Equipped with a pressure gage having a full-scale reading of not more than 300 psi
3. Able to continuously grout the longest tendon on the project in less than 20 minutes

Grout must pass through a screen with clear openings of 1/16 inch or less before entering the pump.

Fit grout injection pipes, ejection pipes, and vents with positive mechanical shutoff valves capable of withstanding the pumping pressures. Do not remove or open valves until the grout has set. If authorized, you may substitute mechanical valves with suitable alternatives after demonstrating their effectiveness.

Provide a standby grout mixer and pump.

50-1.03B(2)(d)(vii) Grout Storage

Store grout in a dry environment.

50-1.03B(2)(d)(viii) Blockages

If the grouting pressure reaches 150 psi, close the inlet and pump the grout at the next vent that has just been or is ready to be closed as long as a one-way flow is maintained. Do not pump grout into a succeeding outlet from which grout has not yet flowed.

When complete grouting of the tendon cannot be achieved by the steps specified, stop the grouting operation.

50-1.03B(2)(d)(ix) Secondary Grouting

Perform secondary grouting by vacuum grouting under the direct supervision of a person who has been trained and has experience in the use of vacuum grouting equipment and procedures.

The vacuum grouting process must be able to determine the size of the void and measure the volume of grout filling the void.

Vacuum grouting equipment must consist of:

1. Volumeter for the measurement of void volume
2. Vacuum pump with capacity of at least 10 cfm and equipped with a flow meter capable of measuring the amount of grout being injected

50-1.03B(2)(d)(x) Vertical Tendon Grouting

Provide a standpipe at the upper end of the tendon to collect bleed water and allow it to be removed from the grout. The standpipe must be large enough to prevent the grout elevation from dropping below the highest point of the upper anchorage device. If the grout level drops to the highest point of the upper anchorage device, immediately add grout to the standpipe.

Remove the standpipe after the grout has hardened.

For vertical tendons in excess of 100 feet high or if grouting pressure exceeds 145 psi, inject grout at a higher vent from which grout has already flowed to maintain one-way flow.

50-1.03B(2)(d)(xi) Vents

Place vents at the following locations:

1. Anchorage areas at both ends of the tendon
2. Each high point
3. 4 feet upstream and downstream of each crest of a high point
4. Each change in the cross section of duct

Add to section 50-1.03B(2):

09-16-11

50-1.03B(2)(e) Debonding Prestressing Strands

Where shown, debond prestressing strands by encasing the strands in plastic sheathing along the entire length shown and sealing the ends of the sheathing with waterproof tape.

Distribute the debonded strands symmetrically about the vertical centerline of the girder. The debonded lengths of pairs of strands must be equal.

Do not terminate debonding at any one cross section of the member for more than 40 percent of the debonded strands or 4 strands, whichever is greater.

Thoroughly seal the ends with waterproof tape to prevent the intrusion of water or cement paste before placing the concrete.

^^

51 CONCRETE STRUCTURES

07-18-14

Replace the paragraphs of section 51-1.01A with:

10-19-12

Section 51-1 includes general specifications for constructing concrete structures.

Earthwork for the following concrete structures must comply with section 19-3:

1. Sound wall footings
2. Sound wall pile caps
3. Culverts
4. Barrier slabs
5. Junction structures
6. Minor structures
7. Pipe culvert headwalls, endwalls, and wingwalls for a pipe with a diameter of 5 feet or greater

Falsework must comply with section 48-2.

Joints must comply with section 51-2.

Elastomeric bearing pads must comply with section 51-3.

Reinforcement for the following concrete structures must comply with section 52:

1. Sound wall footings
2. Sound wall pile caps
3. Barrier slabs
4. Junction structures
5. Minor structures
6. PC concrete members

You may use RSC for a concrete structure only where the specifications allow the use of RSC.

Replace "sets" in the 1st paragraph of section 51-1.01C(2) with:

07-19-13

copies

Replace the heading of section 51-1.01D(4) with:

04-19-13

Testing Concrete Surfaces

Add to section 51-1.01D(4)(a):

04-19-13

The Engineer tests POC deck surfaces for smoothness and crack intensity.

Add to the list in the 1st paragraph of section 51-1.01D(4)(b):

04-19-13

3. Completed deck surfaces, including ramps and landings of POCs

Replace the 4th paragraph in section 51-1.01D(4)(b) with:

04-19-13

Except for POCs, surface smoothness is tested using a bridge profilograph under California Test 547. Two profiles are obtained in each lane approximately 3 feet from the lane lines and 1 profile is obtained in each shoulder approximately 3 feet from the curb or rail face. Profiles are taken parallel to the direction of traffic.

Add between the 5th and 6th paragraphs of section 51-1.01D(4)(b):

04-19-13

POC deck surfaces must comply with the following smoothness requirements:

1. Surfaces between grade changes must not vary more than 0.02 foot from the lower edge of a 12-foot-long straightedge placed parallel to the centerline of the POC
2. Surface must not vary more than 0.01 foot from the lower edge of a 6-foot-long straightedge placed perpendicular to the centerline of the POC

Add to section 51-1.01D(4)(d):

04-19-13

The Engineer measures crack intensity of POC deck surfaces after curing, before prestressing, and before falsework release. Clean the surface for the Engineer to measure surface crack intensity.

In any 100 sq ft portion of a new POC deck surface, if there are more than 10 feet of cracks having a width at any point of over 0.02 inch, treat the deck with methacrylate resin under section 15-5.05. Treat the entire deck width between the curbs to 5 feet beyond where the furthest continuous crack emanating from the 100 sq ft section is 0.02 inch wide. Treat the deck surface before grinding.

Replace the 2nd paragraph of section 51-1.02B with:

07-19-13

Except for minor structures, the minimum required 28-day compressive strength for concrete in structures or portions of structures is the compressive strength described or 3,600 psi, whichever is greater.

Add to section 51-1.03C(2)(c)(i):

04-20-12

Permanent steel deck forms are only allowed where shown or if specified as an option in the special provisions.

Replace the 3rd paragraph of section 51-1.03C(2)(c)(ii) with:

04-20-12

Compute the physical design properties under AISI's *North American Specification for the Design of Cold-Formed Steel Structural Members*.

Replace the 8th paragraph of section 51-1.03D(1) with:

10-19-12

Except for concrete placed as pipe culvert headwalls and endwalls, slope paving and aprons, and concrete placed under water, consolidate concrete using high-frequency internal vibrators within 15 minutes of placing concrete in the forms. Do not attach vibrators to or hold them against forms or reinforcing steel. Do not displace reinforcement, ducts, or prestressing steel during vibrating.

Add to section 51-1.03E(5):

08-05-11

Drill the holes without damaging the adjacent concrete. If reinforcement is encountered during drilling before the specified depth is attained, notify the Engineer. Unless coring through the reinforcement is authorized, drill a new hole adjacent to the rejected hole to the depth shown.

Add to section 51-1.03F(5)(a):

04-19-13

For approach slabs, sleeper slabs, and other roadway surfaces of concrete structures, texture the roadway surface as specified for bridge deck surfaces in section 51-1.03F(5)(b).

Replace "Reserved" in section 51-1.03F(5)(b) with:

07-18-14

51-1.03F(5)(b)(i) General

Except for bridge widenings, texture roadway surfaces of bridge decks, approach slabs, and sleeper slabs, and other roadway surfaces of concrete structures longitudinally by grinding and grooving or by longitudinal tining.

For bridge widenings, texture the roadway surfaces longitudinally by longitudinal tining.

04-20-12

In freeze-thaw areas, do not texture PCC surfaces of bridge decks.

51-1.03F(5)(b)(ii) Grinding and Grooving

When texturing the deck surface by grinding and grooving, place a 1/4 inch of sacrificial concrete cover on the bridge deck above the finished grade shown. Place items to be embedded in the concrete based on the final profile grade elevations shown. Construct joint seals after completing the grinding and grooving.

Before grinding and grooving, deck surfaces must comply with the smoothness and deck crack treatment requirements.

Grind and groove the deck surface as follows:

1. Grind the surface to within 18 inches of the toe of the barrier under section 42-3. Grinding must not reduce the concrete cover on reinforcing steel to less than 1-3/4 inches.
2. Groove the ground surfaces longitudinally under section 42-2. The grooves must be parallel to the centerline.

51-1.03F(5)(b)(iii) Longitudinal Tining

When texturing the deck surface by longitudinal tining, perform initial texturing with a burlap drag or broom device that produces striations parallel to the centerline. Perform final texturing with spring steel tines that produce grooves parallel with the centerline.

The tines must:

1. Be rectangular in cross section
2. Be from 3/32 to 1/8 inch wide on 3/4-inch centers
3. Have enough length, thickness, and resilience to form grooves approximately 3/16 inch deep

Construct grooves to within 6 inches of the layout line of the concrete barrier toe. Grooves must be from 1/8 to 3/16 inch deep and 3/16 inch wide after concrete has hardened.

For irregular areas and areas inaccessible to the grooving machine, you may hand construct grooves. Hand-constructed grooves must comply with the specifications for machine-constructed grooves.

Tining must not cause tearing of the deck surface or visible separation of coarse aggregate at the surface.

Add to section 51-1.03F:

04-19-13

51-1.03F(6) Finishing Pedestrian Overcrossing Surfaces

Construct deck surfaces, including ramps and landings of POCs to the grade and cross section shown. Surfaces must comply with the specified smoothness, surface texture, and surface crack requirements.

The Engineer sets deck elevation control points for your use in establishing the grade and cross section of the deck surface. The grade established by the deck elevation control points includes all camber allowances. Except for landings, elevation control points include the beginning and end of the ramp and will not be closer together than approximately 8 feet longitudinally and 4 feet transversely to the POC centerline. Landing elevation control points are at the beginning and the end of the landing.

Broom finish the deck surfaces of POCs. Apply the broom finish perpendicular to the path of travel. You may apply water mist to the surface immediately before brooming.

Clean any discolored concrete by abrasive blast cleaning or other authorized methods.

Replace the paragraphs of section 51-1.04 with:

10-19-12

If concrete involved in bridge work is not designated by type and is not otherwise paid for under a separate bid item, the concrete is paid for as structural concrete, bridge.

The payment quantity for structural concrete includes the volume in the concrete occupied by bar reinforcing steel, structural steel, prestressing steel materials, and piling.

The payment quantity for seal course concrete is the actual volume of seal course concrete placed except the payment quantity must not exceed the volume of concrete contained between vertical planes 1 foot outside the neat lines of the seal course shown. The Department does not adjust the unit price for an increase or decrease in the seal course concrete quantity.

Structural concrete for pier columns is measured as follows:

1. Horizontal limits are vertical planes at the neat lines of the pier column shown.
2. Bottom limit is the bottom of the foundation excavation in the completed work.
3. Upper limit is the top of the pier column concrete shown.

The payment quantity for drill and bond dowel is determined from the number and depths of the holes shown.

Replace section 51-2.01B(2) with:

04-19-13

51-2.01B(2) Reserved

04-19-13

Delete the 4th paragraph of section 51-2.01C.

Replace "SSPC-QP 3" in the 1st paragraph of section 51-2.02A(2) with:

10-19-12

AISC-420-10/SSPC-QP 3

Replace the 2nd and 3rd paragraphs of section 51-2.02B(3)(b) with:

04-20-12

Concrete saws for cutting grooves in the concrete must have diamond blades with a minimum thickness of 3/16 inch. Cut both sides of the groove simultaneously for a minimum 1st pass depth of 2 inches. The completed groove must have:

1. Top width within 1/8 inch of the width shown or ordered
2. Bottom width not varying from the top width by more than 1/16 inch for each 2 inches of depth
3. Uniform width and depth

Cutting grooves in existing decks includes cutting any conflicting reinforcing steel.

Replace "sets" in the 1st and 2nd paragraphs of section 51-2.02D(1)(c)(ii) with:

04-19-13

copies

Replace "set" in the 7th paragraph of section 51-2.02D(1)(c)(ii) with:

04-19-13

copy

Add to the 1st paragraph of section 51-2.02D(3):

04-19-13

POC deck surfaces must comply with section 51-1.03F(6) before placing and anchoring joint seal assemblies.

Replace "sets" in the 2nd paragraph of section 51-2.02E(1)(c) with:

04-19-13

copies

Replace "set" in the 6th paragraph of section 51-2.02E(1)(c) with:

04-19-13

copy

Replace the 2nd paragraph of section 51-2.02E(1)(e) with:

08-05-11

Except for components in contact with the tires, the design loading must be the AASHTO LRFD Bridge Design Specifications Design Truck with 100 percent dynamic load allowance. Each component in contact with the tires must support a minimum of 80 percent of the AASHTO LRFD Bridge Design Specifications Design Truck with 100 percent dynamic load allowance. The tire contact area must be 10 inches measured normal to the longitudinal assembly axis by 20 inches wide. The assembly must provide a smooth-riding joint without slapping of components or tire rumble.

Replace "sets" in the 1st and 2nd paragraphs of section 51-2.02F(1)(c) with:

04-19-13

copies

Add between the 1st and 2nd paragraphs of section 51-4.01A:

10-19-12

Prestressing concrete members must comply with section 50.

04-20-12

Delete the 2nd paragraph of section 51-4.01A.

Replace the 3rd paragraph of section 51-4.01C(2) with:

04-20-12

For segmental or spliced-girder construction, shop drawings must include the following additional information:

1. Details showing construction joints or closure joints

2. Arrangement of bar reinforcing steel, prestressing tendons, and pressure-grouting pipe
3. Materials and methods for making closures
4. Construction joint keys and surface treatment
5. Other requested information

For segmental girder construction, shop drawings must include concrete form and casting details.

Replace "sets" in the 1st paragraph of section 51-4.01C(3) with:

04-19-13

copies

10-19-12

Delete the 1st and 2nd paragraphs of section 51-4.02A.

Replace the 3rd paragraph of section 51-4.02B(2) with:

04-20-12

For segmental or spliced-girder construction, materials for construction joints or closure joints at exterior girders must match the color and texture of the adjoining concrete.

Add to section 51-4.02B(2):

04-20-12

At spliced-girder closure joints:

1. If shear keys are not shown, the vertical surfaces of the girder segment ends must be given a coarse texture as specified for the top surface of PC members.
2. Post-tensioning ducts must extend out of the vertical surface of the girder segment closure end sufficiently to facilitate splicing of the duct.

For spliced girders, pretension strand extending from the closure end of the girder segment to be embedded in the closure joint must be free of mortar, oil, dirt, excessive mill scale and scabby rust, and other coatings that would destroy or reduce the bond.

Add to section 51-4.03B:

04-20-12

The specifications for prestressing force distribution and sequencing of stressing in the post-tensioning activity in 50-1.03B(2)(a) do not apply if post-tensioning of spliced girders before starting deck construction is described. The composite deck-girder structure must be post-tensioned in a subsequent stage.

Temporary spliced-girder supports must comply with the specifications for falsework in section 48-2.

Before post-tensioning of spliced girders, remove the forms at CIP concrete closures and intermediate diaphragms to allow inspection for concrete consolidation.

Add to section 51-5.01A:

07-19-13

Structure excavation and backfill must comply with section 19-3.
Treated permeable base must comply with section 29.

Replace the paragraph in section 51-5.02G with:

04-18-14

HMA for a temporary roadway structural section must comply with the specifications for minor HMA in section 39.

07-19-13

Delete the 1st paragraph of section 51-5.03B(3).

07-19-13

Delete the 2nd paragraph of section 51-5.03D(1).

Add between the 1st and 2nd paragraphs of section 51-7.01A:

10-19-12

Minor structures include:

1. Pipe culvert headwalls and endwalls for a pipe with a diameter less than 5 feet
2. Drainage inlets
3. Other structures described as minor structures

10-19-12

Delete the 4th paragraph of section 51-7.01A.

Replace the 1st and 2nd paragraphs of section 51-7.01B with:

10-19-12

Concrete must comply with the specifications for minor concrete.

Add to section 51:

10-19-12

51-8-51-15 RESERVED

^^

52 REINFORCEMENT

07-18-14

Add to section 52-1.01A:

07-20-12

Splicing of bar reinforcement must comply with section 52-6.

Replace the 1st and 2nd paragraphs of section 52-1.02B with:

10-19-12

Reinforcing bars must be deformed bars complying with ASTM A 706/A 706M, Grade 60, except you may use:

1. Deformed bars complying with ASTM A 615/A 615M, Grade 60, in:
 - 1.1. Junction structures
 - 1.2. Sign and signal foundations
 - 1.3. Minor structures
 - 1.4. Concrete crib members
 - 1.5. Mechanically-stabilized-embankment concrete panels
 - 1.6. Masonry block sound walls
2. Deformed or plain bars complying with ASTM A 615/A 615M, Grade 40 or 60, in:
 - 2.1. Slope and channel paving
 - 2.2. Concrete barriers Type 50 and 60
3. Plain bars for spiral or hoop reinforcement in structures and concrete piles

Add to the list in the 3rd paragraph of section 52-1.02B:

04-20-12

9. Shear reinforcement stirrups in PC girders

Replace the 9th paragraph of section 52-1.03D with:

07-18-14

Terminate each unit of spiral reinforcement at both ends by lapping the spiral reinforcement on itself for at least 80 diameters followed by (1) a 135-degree hook with a 6-inch tail hooked around an intersecting longitudinal bar or (2) a mechanical lap splice coupler. Discontinuities in spiral reinforcement may be made only where shown or authorized. The spiral on each side of a discontinuity or a lap splice is a separate unit. Where discontinuities in spiral reinforcement are not allowed, splice the spiral reinforcement. Lap splices in spiral reinforcement must be lapped at least 80 diameters followed by (1) a 135-degree hook with a 6-inch tail hooked around an intersecting longitudinal bar or (2) a mechanical lap splice coupler.

Add to section 52-5.01D:

07-18-14

52-5.01D(4) Quality Assurance Testing

Secure, identify, and transport QA headed bar reinforcement test samples to METS as specified for splice test samples in section 52-5.01D(3)(b).

The Department tests headed bar reinforcement as specified for QC testing in section 52-5.01D(3)(b).

The Department will notify you of the QA test results for each bundle of 4 test samples of splices within 3 business days after METS receives the bundle unless more than 1 bundle is received on the same day, in which case allow 2 additional business days for each additional bundle received.

Replace the 6th paragraph of section 52-6.01D(4)(a) with:

01-18-13

Before performing service splice or ultimate butt splice testing, perform total slip testing on the service splice or ultimate butt splice test samples under section 52-6.01D(4)(b).

Replace section 52-6.02D with:

10-21-11

52-6.02D Ultimate Butt Splice Requirements

When tested under California Test 670, ultimate butt splice test samples must demonstrate necking as either of the following:

- 1. For "Necking (Option I)," the test sample must rupture in the reinforcing bar outside of the affected zone and show visible necking.
- 2. For "Necking (Option II)," the largest measured strain must be at least:
 - 2.1. Six percent for no. 11 and larger bars
 - 2.2. Nine percent for no. 10 and smaller bars

Replace the 2nd and 3rd paragraphs of section 52-6.03B with:

01-18-13

Do not splice the following by lapping:

- 1. No. 14 bars
- 2. No. 18 bars
- 3. Hoops
- 4. Reinforcing bars where you cannot provide a minimum clear distance of 2 inches between the splice and the nearest adjacent bar

^^

53 SHOTCRETE

07-19-13

Replace the 2nd and 3rd paragraphs of section 53-2.01D(1) with:

07-19-13

Obtain and test all cores for compressive strength under ASTM C 42/C 42M at an authorized laboratory. The compressive strength is the average strength of the 3 cores.

Shotcrete must have a minimum compressive strength of 3,600 psi, unless otherwise described. The shotcrete must attain the minimum compressive strength at 28 days, except 42 days are allowed for shotcrete with a described minimum compressive strength greater than 3,600 psi.

^^

54 WATERPROOFING

04-18-14

Add between "be" and "3/8 inch" in the 3rd paragraph of section 54-4.02C:

04-20-12

at least

04-18-14

Delete the 3rd paragraph of section 54-5.01A.

04-18-14

Delete "and HMA" in the 2nd paragraph of section 54-5.03.

Replace the last paragraph of section 54-5.03 with:

04-18-14

Do not allow traffic on the seal until HMA is placed over it.

Add to section 54:

07-19-13

54-7 SILANE WATERPROOFING TREATMENT

Reserved

54-8-54-10 RESERVED

^^

55 STEEL STRUCTURES

07-19-13

07-19-13

Delete the 3rd paragraph in section 55-1.01C(1).

Replace the 3rd sentence of the 4th paragraph in section 55-1.01C(1) with:

07-19-13

For ASTM F 1554 anchor bolts, include chemical composition and carbon equivalence for each heat of steel.

Add to section 55-1.01C(1):

07-19-13

For HS connections, submit a record of which lots are used in each joint as an informational submittal.

Replace "sets" at each occurrence in the 1st paragraph of section 55-1.01C(2) with:

04-19-13

copies

Replace the list in the 2nd paragraph of section 55-1.01C(2) with:

07-19-13

1. Sequence of shop and field assembly and erection. For continuous members, include proposed steel erection procedures with calculations that show girder capacity and geometry will be correct.
2. Welding sequences and procedures.
3. Layout drawing of the entire structure with locations of butt welded splices.
4. Locations of temporary supports and welds.
5. Vertical alignment of girders at each stage of erection.
6. Match-marking diagrams.
7. Details for connections not shown or dimensioned on the plans.
8. Details of allowed options incorporated in the work.
9. Direction of rolling of plates where orientation is specified.
10. Distortion control plan.
11. Dimensional tolerances. Include measures for controlling accumulated error to meet overall tolerances.
12. Material specification and grade listed on the bill of materials.
13. Identification of tension members and fracture critical members.
14. Proposed deviations from plans, specifications, or previously submitted shop drawings.
15. Contract plan sheet references for details.

Replace items 2 and 3 in the list in the 1st paragraph of section 55-1.01C(3) with:

07-19-13

2. Tension flanges and webs of horizontally curved girders
3. Hanger plates

Replace the 2nd paragraph of section 55-1.01C(3) with:

07-19-13

Furnish plates, shapes, or bars with extra length to provide for removal of check samples.

07-19-13

Delete the 1st and 2nd sentences in the 3rd paragraph of section 55-1.01C(3).

Replace the 4th paragraph of section 55-1.01C(3) with:

07-19-13

Remove material for test samples in the Engineer's presence. Test samples for plates over 24 inches wide must be 10 by 12 inches with the long dimension transverse to the direction of rolling. Test samples for other products must be 12 inches long taken in the direction of rolling with a width equal to the product width.

Replace the 1st sentence of the 6th paragraph in section 55-1.01C(3) with:

07-19-13

Results of check testing are delivered to you within 20 days of receipt of samples at METS.

07-19-13

Delete the 2nd paragraph of section 55-1.01D(1).

Replace the 2nd sentence of the 4th paragraph in section 55-1.01D(1) with:

07-19-13

The calibration must be performed by an authorized repair and calibration center approved by the tool manufacturer.

Add to section 55-1.01D(1):

07-19-13

For bolts installed as snug tight, rotational capacity testing and installation tension testing are not required.

In addition to NDT requirements in AWS D1.5, ultrasonically test 25 percent of all main member tension butt welds in material over 1/2 inch thick.

Perform NDT on 100 percent of each pin as follows:

1. MT under ASTM A 788, S 18, with no linear indication allowed exceeding 3 mm
2. UT under ASTM A 788, S 20, level S and level DA in two perpendicular directions

The Engineer determines the location of all NDT testing for welding.

07-19-13

Delete the 2nd paragraph of section 55-1.01D(3)(a).

Replace section 55-1.01D(4)(b) with:

07-19-13

Perform rotational capacity testing on each rotational capacity lot under section 55-1.01D(3)(b) at the job site before installation.

Replace the 1st sentence of the 2nd paragraph in section 55-1.01D(4)(c) with:

07-19-13

Test 3 representative HS fastener assemblies under section 8 of *Specification for Structural Joints Using High-Strength Bolts* of the RCSC.

Replace the 1st paragraph in section 55-1.01D(4)(d) with:

07-19-13

Perform fastener tension testing to verify minimum tension in HS bolted connections no later than 48 hours after all fasteners in a connection have been tensioned.

Replace the 3rd paragraph in section 55-1.01D(4)(d) with:

07-19-13

Test 10 percent of each type of fastener assembly in each HS bolted connection for minimum tension using the procedure described in section 10 of *Specification for Structural Joints Using High-Strength Bolts* of the RCSC. Check at least 2 assemblies per connection. For short bolts, determine the inspection torque using steps 1 through 7 of "Arbitration of Disputes, Torque Method-Short Bolts" in *Structural Bolting Handbook* of the Steel Structures Technology Center.

Replace the 1st table in the 1st paragraph of section 55-1.02A(1) with:

07-19-13

Structural Steel

Material	Specification
Carbon steel	ASTM A 709/A 709M, Grade 36 or {ASTM A36/A36M} ^a
HS low alloy columbium vanadium steel	ASTM A 709/A 709M, Grade 50 or {ASTM A 992/A 992M or ASTM A 572/A 572M, Grade 50} ^a
HS low alloy structural steel	ASTM A 709/A 709M, Grade 50W or Grade HPS 50W, or {ASTM A 588/A 588M} ^a
HS low alloy structural steel plate	ASTM A 709/A 709M, Grade HPS 70W
High-yield strength quenched and tempered alloy steel plate suitable for welding	ASTM A 709/A 709M, Grade 100, Grade 100W, or Grade HPS 100W, or {ASTM A 514/A 514M} ^a

^aGrades you may substitute for the equivalent ASTM A 709 steel subject to the modifications and additions specified and to the requirements of ASTM A 709.

Replace the 2nd table in the 1st paragraph of section 55-1.02A(1) with:

07-19-13

Fasteners	
Material	Specification
Steel fastener components for general applications:	
Bolts and studs	ASTM A 307
Anchor bolts	ASTM F 1554 ^a
HS bolts and studs	ASTM A 449, Type 1 ^a
HS threaded rods	ASTM A 449, Type 1 ^a
HS nonheaded anchor bolts	ASTM F 1554, Grade 105, Class 2A ^a
Nuts	ASTM A 563, including appendix X1 ^b
Washers	ASTM F 844
Hardened Washers	ASTM F 436, Type 1, including S1 supplementary requirements
Components of HS steel fastener assemblies for use in structural steel joints:	
Bolts	ASTM A 325, Type 1
Tension control bolts	ASTM F 1852, Type 1
Nuts	ASTM A 563, including appendix X1 ^b
Hardened washers	ASTM F 436, Type 1, Circular, including S1 supplementary requirements
Direct tension indicators	ASTM F 959, Type 325, zinc-coated

^aUse hardened washers.

^bZinc-coated nuts tightened beyond snug or wrench tight must be furnished with a dry lubricant complying with supplementary requirement S2 in ASTM A 563.

Replace the 3rd table in the 1st paragraph of section 55-1.02A(1) with:

07-19-13

Other Materials

Material	Specification
Carbon steel for forgings, pins, and rollers	ASTM A 668/A 668M, Class D
Alloy steel for forgings	ASTM A 668/A 668M, Class G
Pin nuts	ASTM A 709/A 709M or ASTM A 563, including appendix X1 ^a
Carbon-steel castings	ASTM A 27/A 27M, Grade 65-35, Class 1
Malleable iron castings	ASTM A 47/A 47M, Grade 32510
Gray iron castings	ASTM A 48, Class 30B
Carbon steel structural tubing	ASTM A 500/A 500M, Grade B, ASTM A 501, ASTM A 847/A 847M, or ASTM A 1085
Steel pipe ^b	ASTM A 53, Type E or S, Grade B; ASTM A 106, Grade B; or ASTM A 139, Grade B
Stud connectors	ASTM A 108

^aZinc-coated nuts tightened beyond snug or wrench tight must be furnished with a dry lubricant complying with supplementary requirement S2 in ASTM A 563.

^bHydrostatic testing will not apply.

Replace the table in the 1st paragraph in section 55-1.02A(2) with:

07-19-13

Material complying with ASTM A 709/A 709M	CVN impact value (ft-lb at temperature)
Grade 36	15 at 40 °F
Grade 50 ^a (Thickness up to 2 inches)	15 at 40 °F
Grade 50W ^a (Thickness up to 2 inches)	15 at 40 °F
Grade 50 ^a (Thickness over 2 inches up to 4 inches)	20 at 40 °F
Grade 50W ^a (Thickness over 2 inches up to 4 inches)	20 at 40 °F
Grade HPS 50W ^a (Thickness up to 4 inches)	20 at 10 °F
Grade HPS 70W (Thickness up to 4 inches)	25 at -10 °F
Grade 100 (Thickness of 2-1/2 inches or less)	25 at 0 °F
Grade 100W (Thickness over 2-1/2 inches up to 4 inches)	35 at 0 °F
Grade HPS 100W (Thickness of 2-1/2 inches or less)	25 at -30 °F
Grade HPS 100W (Thickness over 2-1/2 inches up to 4 inches)	35 at -30 °F

^aIf the material yield strength is more than 65,000 psi, reduce the temperature for the CVN impact value 15 degrees F for each increment of 10,000 psi above 65,000 psi.

Replace the 1st sentence of the 1st paragraph in section 55-1.02A(5) with:

07-19-13

Steel, gray iron, and malleable iron castings must have continuous fillets cast in place in reentrant angles.

07-19-13

Delete the 3rd and 4th sentences in the 2nd paragraph in section 55-1.02A(5).

Replace the 1st paragraph of section 55-1.02B(1) with:

07-19-13

Section 55-1.02B(1) applies to work performed at the source and at the job site.

Replace the 4th paragraph in section 55-1.02B(1) with:

07-19-13

Ends of girder stiffeners shown as tight-fit must bear on the girder flange with at least point bearing. Local clearances between the end of the stiffener and the girder flange must be at most 1/16 inch.

Replace the 1st sentence of the 5th paragraph in section 55-1.02B(1) with:

07-19-13

Fabricate floor beams, stringers, and girders having end connection angles to exact length back to back of connection angles.

Add to the 7th paragraph in section 55-1.02B(1):

07-19-13

Use low-stress stamps for fracture critical members and tension members.

Replace the 2nd sentence of the 9th paragraph in section 55-1.02B(1) with:

07-19-13

Slightly round edges and sharp corners, including edges marred, cut, or roughened during handling or erection.

Replace the 3rd paragraph in section 55-1.02B(2) with:

07-19-13

Instead of machining, you may heat straighten steel not in contact with other metal bearing surfaces if the above tolerances are met.

Replace item 2 in the list in the 1st paragraph of section 55-1.02B(3) with:

07-19-13

2. Radius of bend measured to the concave face must comply with *Manual of Steel Construction* of the AISC

Replace the 1st sentence of the 2nd paragraph in section 55-1.02B(3) with:

07-19-13

Plates to be bent to a smaller radius than specified in *Manual of Steel Construction* of the AISC must be bent hot.

Replace the introductory clause of the 2nd paragraph of section 55-1.02B(4) with:

07-19-13

Threads for pin ends and pin nuts 1-1/2 inches or more in diameter must comply with the following:

Replace the 3rd paragraph in section 55-1.02B(5) with:

07-19-13

Holes for pins must be:

1. True to the diameter specified.
2. At right angles to the member axis.
3. Parallel with each other except for pins where nonparallel holes are required.

4. Smooth and straight with the final surface produced by a finishing cut.

Replace the 1st paragraph in section 55-1.02B(6)(c) with:

07-19-13

Bolted connections using HS fastener assemblies must comply with *Specification for Structural Joints Using High-Strength Bolts* of the RCSC.

Replace the 7th paragraph in section 55-1.02B(6)(c) with:

07-19-13

For all bolts, thread stickout after tensioning must be at least flush with the outer nut face. At least 3 full threads must be located within the grip of the connection.

07-19-13

Delete the 3rd paragraph in section 55-1.02B(7)(a).

Add to section 55-1.02B(7)(a):

07-19-13

For welds indicated to be subject to tensile forces that are to receive RT, grind smooth and flush on both sides of welds before testing.

For groove weld surface profiles that interfere with NDT procedures, grind welds smooth and blend with the adjacent material.

For fillet weld surface profiles that interfere with NDT procedures, grind welds and blend the toes smoothly with the adjacent base metal.

Add to section 55-1.02B(7):

07-19-13

55-1.02B(7)(c) Steel Pedestrian Bridges

Reserved

Replace the 1st paragraph in section 55-1.02B(9) with:

07-19-13

Prepare and paint contact surfaces of HS bolted connections before assembly. Thoroughly clean all other surfaces of metal in contact to bare metal before assembly. Remove all rust, mill scale, and foreign material.

Replace the 1st sentence of the 4th paragraph in section 55-1.02B(9) with:

07-19-13

Preassemble truss work in lengths of at least 3 abutting panels and adjust members for line and camber.

Replace the 1st sentence of the 5th paragraph in section 55-1.02B(9) with:

07-19-13

Preassemble bolted splice joints for plate girders in lengths of at least 3 abutting sections and adjust abutting sections for line and camber.

Replace the 6th paragraph in section 55-1.02B(9) with:

07-19-13

Preassemble prepared splice joints for welded girders with abutting members and adjust for line and camber.

Replace the paragraphs in section 55-1.03C(1) with:

07-19-13

Reserved

Replace the 3rd sentence of the 1st paragraph in section 55-1.03C(2) with:

07-19-13

Attain full bearing on the concrete under bearing assemblies.

Replace the 3rd paragraph in section 55-1.03C(2) with:

07-19-13

During welding, protect bearings and bearing surfaces using authorized methods.

Replace section 55-1.03C(4) with:

07-19-13

55-1.03C(4) Continuous Members

Unless otherwise shown, structural steel girders are designed for continuity in supporting girder dead load. If erection procedures provide girder continuity for dead load, preassemble members with field joints in a no-load condition in a horizontal or an upright condition.

You may erect structural steel girders such that dead load girder continuity is not provided. If erection procedures do not provide girder continuity for dead load:

1. You may increase cross-sectional areas or change grades of steel to provide the specified capacity if authorized.
2. After erection, the erected structure must have a load-carrying capacity at least equal to the structure shown.

^^

56 SIGNS

07-19-13

Replace the 4th paragraph of section 56-3.01A with:

07-19-13

The types of sign structures include:

- 1. Truss
- 2. Bridge mounted
- 3. Tubular

Replace "sets" in the 1st paragraph of section 56-3.01C(2) with:

04-19-13

copies

07-20-12

Delete the 7th paragraph of section 56-3.02K(2).

Replace the 1st paragraph of section 56-3.02M(1) with:

07-19-13

Galvanize all ferrous metal parts of the following sign structure types:

- 1. Truss
- 2. Bridge mounted
- 3. Tubular

Add between the 1st and 2nd paragraphs of section 56-3.02M(1):

04-19-13

Clean and paint all ferrous metal parts of tubular sign structures after galvanizing, including the areas to be covered by sign panels. Do not paint sign structures other than tubular type unless specified in the special provisions.

Replace the headings and paragraphs in section 56-3.02M(3) with:

04-19-13

Where specified, clean and paint sign structures under section 59-5.

^^

57 WOOD AND PLASTIC LUMBER STRUCTURES

04-19-13

Replace "51-2.01C(3)" in the 1st paragraph of section 57-2.01C(3)(a) with:

10-19-12

57-2.01C(3)

Replace "sets" at each occurrence in the 1st paragraph of section 57-3.01C with:

04-19-13

copies

^^

58 SOUND WALLS

04-19-13

10-19-12

Delete the 3rd paragraph of section 58-1.01.

Replace the 1st paragraph of section 58-2.01D(5)(a) with:

08-05-11

You must employ a special inspector and an authorized laboratory to perform Level 1 inspections and structural tests of masonry to verify the masonry construction complies with section 1704, "Special Inspections," and section 2105, "Quality Assurance," of the 2007 CBC.

10-19-12

Delete the 1st paragraph of section 58-2.02F.

Replace "sets" at each occurrence in the 1st paragraph of section 58-4.01C with:

04-19-13

copies

^^

59 PAINTING

11-15-13

Replace "SSPC-SP 10" at each occurrence in section 59 with:

10-19-12

SSPC-SP 10/NACE no. 2

Replace "SSPC-SP 6" at each occurrence in section 59 with:

10-19-12

SSPC-SP 6/NACE no. 3

Replace "SSPC-CS 23.00" at each occurrence in section 59 with:

10-19-12

SSPC-CS 23.00/AWS C 2.23M/NACE no. 12

Replace "*Specification for Structural Joints Using ASTM A325 or A 490 Bolts*" in the 1st paragraph of section 59-2.01C(1) with:

07-19-13

Specification for Structural Joints Using High-Strength Bolts

Replace "SSPC-QP 3 or AISC SPE, Certification P-1 Enclosed" in item 3 in the list in the 1st paragraph of section 59-2.01D(1) with:

10-19-12

AISC-420-10/SSPC-QP 3 (Enclosed Shop)

Replace "*Specification for Structural Joints Using ASTM A325 or A 490 Bolts*" in the 1st paragraph of section 59-2.02 with:

07-19-13

Specification for Structural Joints Using High-Strength Bolts

Replace the paragraphs in section 59-2.03A with:

10-19-12

Clean and paint all exposed structural steel and other metal surfaces.

You must provide enclosures for cleaning and painting structural steel. Cleaning and painting of new structural steel must be performed in an Enclosed Shop as defined in AISC-420-10/SSPC-QP 3. Maintain atmospheric conditions inside enclosures within specified limits.

Except for blast cleaning within closed buildings, perform blast cleaning and painting during daylight hours.

Add to section 59-2.03B:

07-19-13

59-2.03B(3) Containment Systems

59-2.03B(3)(a) General

Construct containment systems when disturbing existing paint systems during bridge rehabilitation.

The containment system must be one of the following:

1. Ventilated containment system
2. Vacuum-shrouded surface preparation equipment and drapes and ground covers
3. Equivalent containment system if authorized

The containment system must contain all water, resulting debris, and visible dust produced when the existing paint system is disturbed.

Properly maintain the containment system while work is in progress and do not change the containment system unless authorized.

Containment systems over railroad property must provide the minimum clearances as specified in section 5-1.20C for the passage of railroad traffic.

59-2.03B(3)(b) Ventilated Containment Systems

59-2.03B(3)(b)(i) General

If flexible framing is used, support and fasten it to (1) prevent the escape of abrasive and blast materials due to whipping from traffic or wind and (2) maintain clearances.

If the wind speed reaches 50 mph or greater, relieve the wind pressure on the containment system using an authorized method.

59-2.03B(3)(b)(ii) Design Criteria

Scaffolding or supports for the ventilated containment system must not extend below the vertical clearance level nor to the ground line at locations within the roadbed.

For truss-type bridges, all connections of the ventilated containment system to the existing structure must be made through the deck, girder, stringer, or floor beam system. No connections are allowed that will cause bending stresses in a truss member.

The ventilated containment system must comply with section 7-1.02K(6)(e).

The minimum total design load for the ventilated containment system must consist of the sum of the dead and live vertical loads.

Dead and live loads are as follows:

1. Dead load must consist of the actual load of the ventilated containment system
2. Live loads for bridges with only spot blast cleaning work must consist of:
 - 2.1. Uniform load of at least 25 psf applied over the supported area
 - 2.2. Moving concentrated load of 1000 lb to produce maximum stress in the main supporting elements of the ventilated containment system
3. Live loads for bridges with 100 percent blast cleaning to bare metal must consist of:
 - 3.1. Uniform load of at least 45 psf, which includes 20 psf of sand load, applied over the supported area
 - 3.2. Moving concentrated load of 1000 lb to produce maximum stress in the main supporting elements of the ventilated containment system

Assumed horizontal loads do not need to be included in the design of the ventilated containment system.

Maximum allowable stresses must comply with section 48-2.01D(3)(c).

59-2.03B(3)(b)(iii) Ventilation

The ventilation system in the ventilated containment system must be of the forced input airflow type with fans or blowers.

Negative air pressure must be employed within the ventilated containment system and will be verified by visual methods by observing the concave nature of the ventilated containment system while taking into

account wind effects or by using smoke or other visible means to observe airflow. The input airflow must be properly balanced with the exhaust capacity throughout the range of operations.

The exhaust airflow of the ventilation system in the ventilated containment system must be forced into wet or dry dust collectors or bag houses.

Replace item 1 in the list in the 2nd paragraph of section 59-2.03C(1) with:

10-19-12

1. Apply a stripe coat of undercoat paint on all edges, corners, seams, crevices, interior angles, junctions of joining members, weld lines, and similar surface irregularities. The stripe coat must completely hide the surface being covered. If spot blast cleaning portions of the bridge, apply the stripe coat of undercoat paint before each undercoat and follow with the undercoat as soon as practical. If removing all existing paint from the bridge, apply the undercoat first as soon as practical and follow with the stripe coat of undercoat paint for each undercoat.

Replace the heading of section 59-2.03C(2) with:

04-19-13

Zinc Coating System

Add to section 59-2.03C(2)(a):

04-19-13

Coatings for new structural steel and connections between new and existing structural steel must comply with the requirements shown in the following table:

Zinc Coating System

Description	Coating	Dry film thickness (mils)
All new surfaces:		
Undercoat	Inorganic zinc primer, AASHTO M 300 Type I or II	4–8
Finish coat ^a	Exterior grade latex ^b , 2 coats	2 minimum each coat, 4–8 total
Total thickness, all coats		8–14
Connections to existing structural steel: ^c		
Undercoat	Inorganic zinc primer, AASHTO M 300 Type I or II	4–8
Finish coat ^a	Exterior grade latex ^b , 2 coats	2 minimum each coat, 4–8 total
Total thickness, all coats		8–14

^aIf no finish coats are described, a final coat of inorganic zinc primer is required.

^bExterior grade latex must comply with section 91-2.02 unless otherwise specified.

^cIncludes the following locations:

1. New and existing contact surfaces
2. Existing member surfaces under new HS bolt heads, nuts, or washers
3. Bare surfaces of existing steel after trimming, cutting, drilling, or reaming
4. Areas within a 4-inch radius from the point of application of heat for welding or flame cutting

Replace "Specification for Structural Joints Using ASTM A325 or A 490 Bolts" in the 7th paragraph of section 59-2.03C(2)(b)(i) with:

07-19-13

Specification for Structural Joints Using High-Strength Bolts

Add to section 59-2.03C:

04-19-13

59-2.03C(3) Moisture-Cured Polyurethane Coating System

Reserved

59-2.03C(4) State Specification Paint Waterborne Coating System

59-2.03C(4)(a) General

The State Specification PWB coating system for existing structural steel must comply with the requirements shown in the following table:

State Specification PWB Coating System

Surface	Description	State Specification PWB Coating	Dry film thickness (mils)
Surfaces cleaned to bare metal ^a :	1st undercoat	145	2-3
	2nd undercoat	146	2-3
	1st finish coat	171	1.5-3
	2nd finish coat	172	1.5-3
	Total thickness, all coats	--	7-12
Existing painted surfaces to be topcoated:	Undercoat	146	2-3
	1st finish coat	171	1.5-3
	2nd finish coat	172	1.5-3
	Total thickness, new coats	--	5-9

^aIncludes locations of spot blast cleaning

59-2.03C(4)(b) Finish Coats

11-15-13

Reserved

Add to section 59-5.01:

04-19-13

Where specified, prepare and paint sign structures under sections 59-2 and 59-3.

Instead of submitting proof of the certification complying with SSPC-QP 1, you may submit documentation with the painting quality work plan showing compliance with the requirements in section 3 of SSPC-QP 1.

Instead of submitting proof of the certification complying with SSPC-QP 2, you may submit documentation with the painting quality work plan showing compliance with the requirements in sections 4.2 through 4.4 of SSPC-QP 2, Category A.

Instead of submitting proof of the certification complying with AISC-420-10/SSPC-QP 3 (Enclosed Shop), you may submit documentation with the painting quality work plan showing compliance with the requirements in sections 5 through 18 of AISC-420-10/SSPC-QP3.

Replace the paragraphs of section 59-5.03 with:

04-19-13

59-5.03A General

You may prepare and paint sign structures before or after erection. After erection, repair damaged paint to the satisfaction of the Engineer.

The total dry film thickness of finish coats on contact surfaces of galvanized HS bolted connections (1) must be from 1 to 4 mils and (2) may be applied in 1 application.

59-5.03B Undercoating of Ungalvanized Surfaces

Blast-cleaned surfaces must receive a single undercoat consisting of an inorganic zinc coating as specified in AASHTO M 300, Type I or Type II, except:

1. The first 2 sentences of section 5.6 do not apply
2. Section 5.6.1 does not apply

If you propose to use a coating that is not on the Authorized Material List, submit the required documentation specified in section 5.6 of AASHTO M 300. Allow 30 days for the Engineer's review.

59-5.03C Testing of Inorganic Zinc Coating

Perform adhesion and hardness testing no sooner than 72 hours after application of the single undercoat of inorganic zinc coating.

59-5.03D Finish Coating

The exposed area of inorganic zinc coating must receive a minimum of 2 finish coats of exterior grade latex paint.

The 1st finish coat color must match no. 24558 of FED-STD-595. The 2nd finish coat color must match no. 24491 of FED-STD-595. The total dry film thickness of the applications of the 2nd finish coat must be not less than 2 mils.

Replace section 59-7 with:

07-19-13

59-7 STAINING CONCRETE AND SHOTCRETE

59-7.01 GENERAL

59-7.01A General

59-7.01A(1) Summary

Section 59-7.01 includes specifications for preparing and staining concrete and shotcrete surfaces using an acid stain.

59-7.01A(2) Definitions

Reserved

59-7.01A(3) Submittals

Submit stain manufacturer's product data and application instructions at least 7 days before starting staining activities.

59-7.01A(4) Quality Control and Assurance

Reserved

59-7.01B Materials

59-7.01B(1) General

Reserved

59-7.01B(2) Stain

Stain must:

1. Be a water-based solution of inorganic metallic salts
2. Contain dilute acid that penetrates and etches the concrete or shotcrete surface
3. Be a commercial quality product designed specifically for exterior applications
4. Produce abrasion-resistant color deposits

59-7.01B(3) Sealer

Reserved

59-7.01B(4) Joint Sealing Compound

Reserved

59-7.01C Construction

59-7.01C(1) General

Seal joints between concrete and shotcrete surfaces to be stained and adjacent metal with joint sealing compound before applying the stain.

Test surfaces for acceptance of the stain before applying the stain. Clean surfaces that resist accepting the stain and retest until passing.

Apply the stain under the manufacturer's instructions.

Before staining, the concrete or shotcrete surfaces must be:

1. At least 28 days old
2. Prepared under SSPC-SP 13/NACE no. 6
3. Thoroughly dry

Apply the stain uniformly to avoid excessive rundown. Work the stain into the concrete using a nylon bristle brush in a circular motion.

After the last coat of stain has dried, rinse stained surfaces with water and wet scrub with a stiff bristle nylon brush until the rinse water runs clear. Collect all rinse water.

Protect adjacent surfaces during staining.

Thoroughly cure each application of the stain and correct skips, holidays, thin areas, or other deficiencies before the next application.

Drips, puddles, or other irregularities must be worked into the concrete or shotcrete surface.

59-7.01C(2) Test Panel

For staining concrete or shotcrete, stain a test panel complying with section 51-1.01D(3).

For staining sculpted shotcrete, stain a test panel complying with section 53-3.01D(3).

The test panel must be:

1. Stained using the same personnel, materials, equipment and methods to be used in the work
2. Accessible for viewing
3. Displayed in an upright position near the work
4. Authorized for staining before starting the staining work

If ordered, construct additional test panels until a satisfactory color is attained.

The Engineer uses the authorized stained test panel to determine the acceptability of the stained surface.

Dispose of the test panels after the staining work is complete and authorized. Notify the Engineer before disposing of the test panels.

59-7.01D Payment

Not Used

59-7.02 SCULPTED SHOTCRETE AND TEXTURED CONCRETE

59-7.02A General

59-7.02A(1) Summary

Section 59-7.02 includes specifications for preparing and staining sculpted shotcrete and textured concrete surfaces using an acid stain.

59-7.02A(2) Definitions

Reserved

59-7.02A(3) Submittals

59-7.02A(3)(a) General

Reserved

59-7.02A(3)(b) Experience Qualifications

Submit the following documentation of the staining subcontractor's experience at least 10 days before the preconstruction meeting:

1. Summary of the staining subcontractor's experience that demonstrates compliance with section 59-7.02A(4)(b).
2. List of at least 3 projects completed in the last 5 years that demonstrate the staining subcontractor's ability to stain textured concrete or sculpted shotcrete surfaces similar to the textured concrete or sculpted shotcrete for this project. For each project include:
 - 2.1. Project description
 - 2.2. Name and phone number of the owner
 - 2.3. Staining completion date
 - 2.4. Color photos of the completed stained surface

59-7.02A(3)(c) Installation Plan

Submit an installation plan at least 10 days before the preconstruction meeting. The installation plan must include details for preparing and staining the textured concrete or sculpted shotcrete to achieve the required color, including:

1. Number of applications that will be used to apply the stain
2. For each application of the stain, a description of:
 - 2.1. Manufacturer, color, finish, and percentage strength mixture of the stain that will be applied
 - 2.2. Methods and tools that will be used to apply the stain
3. Methods for protecting adjacent surfaces during staining

4. Rinse water collection plan for containing all liquid, effluent, and residue resulting from preparing and staining textured concrete or sculpted shotcrete

59-7.02A(4) Quality Control and Assurance

59-7.02A(4)(a) General

Reserved

59-7.02A(4)(b) Contractor Qualifications

The staining subcontractor must:

1. Have experience in staining textured concrete or sculpted shotcrete surfaces to simulate the appearance of natural rock formations or stone masonry
2. Have successfully completed at least 3 projects in the past 5 years involving staining of concrete or sculpted shotcrete surfaces similar to the textured concrete or sculpted shotcrete for this project

59-7.02A(4)(c) Preconstruction Meeting

Before starting staining activities, conduct a meeting to discuss the installation plan. Meeting attendees must include the Engineer and all staining subcontractors.

59-7.02B Materials

Not Used

59-7.02C Construction

Not Used

59-7.02D Payment

Prepare and stain concrete and prepare and stain shotcrete are measured by the area of the vertical or sloped wall face stained.

Replace "solider" in the 5th paragraph of section 59-9.03 with:

04-19-13

soldier

Replace section 59-11 with:

07-19-13

59-11 STAINING GALVANIZED SURFACES

Reserved

59-12 ROCK STAINING

59-12.01 GENERAL

59-12.01A Summary

Section 59-12 includes specifications for applying stain to the exterior surface of landscape boulders, native rock that has been damaged or scarred, rock energy dissipaters, rock slope protection and gabion surfaces.

59-12.01B Submittals

Submit the following:

1. Work plan showing methods to control overspray and spillage, and to protect adjacent surfaces
2. Product data including the manufacturer's product sheet and the instructions for the application of the stain

59-12.01C Quality Control and Assurance

59-12.01C(1) General

Reserved

59-12.01C(2) Test Plot

Apply the stain to a test plot rock area of at least 3 by 3 feet at a location designated by the Engineer. Notify the Engineer at least 7 days before staining the test plot. Prepare and stain the test plot with the same materials, tools, equipment, and methods to be used in staining the final surfaces. Separate test plots are required for staining rock slope protection and native rock.

If ordered, prepare additional test plots. Additional test plots are change order work.

Obtain authorization of the test plot before starting the staining work. Use the authorized test plot as the standard for comparison in determining acceptability of staining. If the test plot is not incorporated into the work and the Engineer determines it is no longer needed, dispose of it.

59-12.02 MATERIALS

59-12.02A General

Reserved

59-12.02B Stain

Reserved

59-12.03 CONSTRUCTION

59-12.03A General

Reserved

59-12.03B Preparation

Before applying the stain:

1. Identify and obtain authorization for the areas to be stained
2. Remove oils, dirt, and other contaminants from the surfaces to be stained
3. Dry all surfaces to be stained

DIVISION VIII MISCELLANEOUS CONSTRUCTION
72 SLOPE PROTECTION

11-15-13

Replace the table in the 3rd paragraph of section 72-2.02A with:

11-15-13

Rock Material Properties

Property	California Test	Value
Apparent specific gravity	206	2.5 minimum
Absorption	206	4.2% maximum
Durability Index	229	52 minimum

Notes:

Durability absorption ratio (DAR) = course durability index/(% absorption + 1)

If the DAR is greater than 10, the absorption may exceed 4.2%

If the DAR is greater than 24, the durability index may be less than 52

Replace the row under "Class" in the table in the 1st paragraph of section 72-3.02B with:

01-20-12

1/2 T	1/4 T	Light	Facing	Cobble
-------	-------	-------	--------	--------

Replace the table in the 2nd paragraph of section 72-3.02B with:

11-15-13

Rock Material Properties

Property	California Test	Value
Apparent specific gravity	206	2.5 minimum
Absorption	206	4.2% maximum
Durability index	229	52 minimum

Notes:

Durability absorption ratio (DAR) = course durability index/(% absorption + 1)

If the DAR is greater than 10, the absorption may exceed 4.2%

If the DAR is greater than 24, the durability index may be less than 52

Replace the row under "Rock class" in the table in the 2nd paragraph of section 72-3.03E with:

01-20-12

1/2 T	1/4 T	Light	Facing	Cobble
-------	-------	-------	--------	--------

07-19-13

Delete the 5th and 6th paragraphs of section 72-11.01B.

Add to section 72-11.01B:

01-18-13

Expanded polystyrene and premolded expansion joint filler must comply with section 51-2.

07-19-13

Delete the 2nd paragraph of section 72-11.01C(1).

07-19-13

Delete the 7th paragraph of section 72-11.01C(1).

Add between the 7th and 8th paragraphs of section 72-11.01C(1):

07-19-13

Schedule the construction of the slope paving such that the work, including placing and finishing concrete and applying curing compound, is completed on the same day that the work is started.

Replace the 8th paragraph of section 72-11.01C(1) with:

07-19-13

If the Engineer determines that the size of the slope paving is too large to be constructed without an intermediate construction joint, place a joint at an authorized location. Complete a section of concrete bounded by permissible construction joints within the same day.

Replace the 1st paragraph of section 72-11.01C(2) with:

01-18-13

Construct and finish minor concrete slope paving under section 51-1.

Replace the 3rd paragraph of section 72-11.01C(2) with:

07-19-13

After striking-off to grade, hand float the concrete with floats that are at least 4 inches wide and 30 inches long. Broom the entire surface with a stiff-bristled broom to produce a uniform surface. Brooming must be done when the surface is sufficiently set to prevent deep scarring and must be accomplished by drawing the broom down the slope, leaving marks parallel to the slope. The Engineer may order you to apply a fine spray of water to the surface immediately before brooming.

07-19-13

Delete the 3rd paragraph of section 72-11.01D.

^^

73 CONCRETE CURBS AND SIDEWALKS

07-19-13

Replace the paragraph in section 73-1.01A with:

07-19-13

Section 73-1 includes general specifications for constructing minor concrete items including concrete curbs, sidewalks, gutter depressions, driveways, island paving, and curb ramps; for installing detectable warning surfaces and precast parking bumpers; and for texturing and coloring concrete surfaces.

^^

74 PUMPING EQUIPMENT AND CONTROLS

04-19-13

Replace the 1st paragraph of section 74-1.01C(3) with:

04-19-13

Submit at least 5 copies of product data to OSD, Documents Unit. Each copy must be bound together and include an index stating equipment names, manufacturers, and model numbers. Two copies will be returned. Notify the Engineer of the submittal. Include in the notification the date and contents of the submittal.

Replace the 1st sentence of the 1st paragraph in section 74-2.01D(2) with:

01-20-12

Drainage pumps must be factory certified under ANSI/HI 14.6.

^^

75 MISCELLANEOUS METAL

07-19-13

Add between 2nd and 3rd paragraphs of section 75-1.03A:

07-19-13

Fabricate expansion joint armor from steel plates, angles, or other structural shapes. Shape the armor to the section of the concrete deck and match-mark it in the shop. Straighten warped sections of expansion joint armor before placing. Secure the expansion joint armor in the correct position during concrete placement.

Replace "SSPC-QP 3" in the 3rd paragraph of section 75-1.03E(4) with:

10-19-12

AISC-420-10/SSPC-QP3

Replace "metal beam guard railing" in the table in the 1st paragraph of section 75-1.05 with:

07-19-13

guardrail

^^

Replace section 78 with:

07-20-12

78 INCIDENTAL CONSTRUCTION

07-20-12

78-1 GENERAL

Section 78 includes specifications for incidental bid items that are not closely associated with other sections.

78-2-78-50 RESERVED

^^

80 FENCES

07-18-14

Add to section 80-2.02D:

10-19-12

Vertical stays must:

- 1. Comply with ASTM A641
- 2. Be 12-1/2 gage
- 3. Have a Class 3 zinc coating

Replace item 1 in the list in section 80-2.02E with:

10-19-12

Comply with ASTM A 116, Type Z, Grade 60, Class 1

Add after "galvanized wire" in the 1st paragraph of section 80-2.02F:

10-19-12

complying with ASTM A 641

Replace the 3rd and 4th paragraphs of section 80-2.02F with:

10-19-12

Each staple used to fasten barbed wire and wire mesh fabric to wood posts must:

1. Comply with ASTM F 1667
2. Be at least 1-3/4 inches long
3. Be manufactured from 9-gage galvanized wire

Wire ties used to fasten barbed wire and wire mesh to metal posts must be at least 11-gage galvanized wire complying with ASTM F 626. Clips and hog rings used for metal posts must be at least 9-gage galvanized wire complying with ASTM F 626.

Replace the 8th through 14th paragraphs of section 80-2.03 with:

10-19-12

Attach the wire mesh and barbed wire to each post.

Securely fasten tension wires to wood posts. Make a single or double loop around each post at each attachment point and staple the wire to the post. Use wire ties, hog rings, or wire clips to fasten the wires to the metal posts.

Connect each wood brace to its adjacent post with a 3/8 by 4-inch steel dowel. Twist the tension wires until the installation is rigid.

Stretch barbed wire and wire mesh fabric and fasten to each wood or steel end, corner, or gate post. Apply tension according to the manufacturer's instructions using a mechanical stretcher or other device designed for such use. If no tension is specified by the manufacturer, use 250 pounds for the required tension. Evenly distribute the pull over the longitudinal wires in the wire mesh such that no more than 50 percent of the original depth of the tension curves is removed. Do not use a motorized vehicle, truck, or tractor to stretch the wire.

Attach barbed wire and wire mesh fabric to the private-property side of posts. On curved alignments, place the wire mesh and barbed wire on the face of the post against which the normal pull of the wire mesh and wire will be exerted. Terminate the wire mesh and barbed wire at each end, corner, pull, and gate post in the new fence line. Attach wire mesh and barbed wire to each wood or steel end, corner, pull, or gate post by wrapping each horizontal strand around the post and tying it back on itself with at least 4 tightly-wound wraps.

At line posts, fasten the wire mesh to the post at the top and bottom and at intermediate points not exceeding 10 inches apart. Fasten each line of barbed wire to each line post. Use wire ties or clips to fasten the wires to metal posts under the post manufacturer's instructions. Drive staples crosswise with the grain of the wood and pointed slightly downward. Drive staples just short of actual contact with the wires to allow free longitudinal movement of those wires and to prevent damage to the wire's protective coating. Secure all wires to posts to maintain horizontal alignment.

Splices in barbed wire and wire mesh are allowed provided there are no more than 2 splices per 50 feet of fence. Use commercially-available galvanized mechanical wire splices or a wire splice created by tying off wire. Install mechanical wire splices with a tool designed for that purpose under the manufacturer's instructions. Tie off the wire as follows:

1. Carry the ends of each wire 3 inches past the tied-off knot location and wrap around the wire for at least 6 turns in opposite directions.
2. Remove the splice tool and close the space by pulling the end of the wires together.
3. Cut the unused ends of the wire close and neat.

DIVISION IX TRAFFIC CONTROL FACILITIES

83 RAILINGS AND BARRIERS

07-18-14

Replace "metal beam guard railing" at each occurrence in sections 83-1.02 and 83-1.03 with:

07-19-13

midwest guardrail system

Replace "guard rail" and "guard railing" at each occurrence in sections 83-1.02A and 83-1.02B with:

07-19-13

guardrail

Replace the heading of section 83-1.02B with:

07-19-13

Midwest Guardrail System

Add between "splices at" and "posts" in the 5th paragraph of section 83-1.02B:

07-19-13

midspan between

Replace "Metal rail posts, box spacers, and" in item 1 in the list in the 25th paragraph of section 83-1.02B with:

07-19-13

Metal box spacers and

Replace item 4 in the list in the 25th paragraph of section 83-1.02B with:

07-18-14

4. For the connection of guard railing to new bridge railing or barriers, anchor bolt holes must be drilled in the concrete parapet or formed using metal or PVC sleeves.

07-19-13

Delete items 6 and 7 in the list in the 25th paragraph of section 83-1.02B.

Replace "Type WB" at each occurrence in section 83-1.02B(2) with:

07-19-13

Type WB-31

Replace the heading of section 83-1.02B(3) with:

07-19-13

Temporary Midwest Guardrail System

Replace the 2nd sentence of the 9th paragraph of section 83-1.02D(1) with:

07-18-14

Posts and balusters must be normal to the profile grade. Transverse to the profile grade, railings must be plumb within a tolerance not to exceed 0.02 foot in 10 feet.

Replace "80-2.02" in the 2nd paragraph of section 83-1.02E with:

10-19-12

80-3.02B

Replace the 3rd paragraph of section 83-1.02G(2) with:

07-18-14

Stud bolts must comply with the specifications for studs in clause 7 of AWS D1.1.

Replace "horizontal" in the 8th paragraph of section 83-1.02G(2) with:

07-18-14

vertical

Replace "sets" in the 10th paragraph of section 83-1.02G(2) with:

07-19-13

copies

Replace the 1st sentence of the 1st paragraph of section 83-1.03 with:

11-15-13

Except for guardrail within the pay limits of a terminal system, a transition railing (Type WB-31), an end anchor assembly, or a rail tensioning assembly, midwest guardrail system is measured along the face of the rail element from end post to end post of the completed railing.

Add to section 83-2.02D(1):

10-21-11

For a concrete barrier transition:

1. Remove portions of the existing concrete barrier where shown under section 15-3
2. Roughen the contact surface of the existing concrete barrier
3. Drill and bond dowels into the existing concrete barrier under section 51-1

Add to section 83-2.02:

10-19-12

83-2.02H–83-2.02M Reserved

^^

84 TRAFFIC STRIPES AND PAVEMENT MARKINGS

05-30-14

Replace section 84-1.01C with:

05-30-14

84-1.01C Submittals

For glass beads used in drop-on applications and in thermoplastic formulations, submit a certificate of compliance and test results for each lot of beads specifying the EPA test methods used and tracing the lot to the specific test sample. The testing for lead and arsenic content must be performed by an independent testing laboratory.

Submit retroreflectivity readings for traffic stripes and pavement markings at locations with deficient retroreflectivity determined by the Engineer.

84-1.01D Quality Control and Assurance

Test each lot of glass beads for arsenic and lead under EPA Test Method 3052 and 6010B or 6010C.

Applied traffic stripes and pavement markings must be retroreflective. Within 30 days of applying traffic stripes and pavement markings, the retroreflectivity of the stripes and markings must be a minimum of $250 \text{ mcd}\cdot\text{m}^{-2}\cdot\text{lx}^{-1}$ for white and $125 \text{ mcd}\cdot\text{m}^{-2}\cdot\text{lx}^{-1}$ for yellow when measured under ASTM E1710.

The Engineer will perform a nighttime, drive-through, visual inspection of the retroreflectivity of the traffic stripes and pavement markings and notify you of any locations with deficient retroreflectivity. Measure the retroreflectivity of the deficient areas using a retroreflectometer under ASTM E1710 and the sampling protocol specified in ASTM D7585.

Replace the paragraph in section 84-1.02 with:

05-30-14

Glass beads applied to paint must comply with State Specification 8010-004.

Glass beads applied to molten thermoplastic material must be Type 2 beads complying with AASHTO M 247. The glass beads must have a coating that promotes adhesion of the beads to thermoplastic.

At least 75 percent of the beads by count must be true spheres that are colorless and do not exhibit dark spots, air inclusions, or surface scratches when viewed under 20X magnification.

Each lot of glass beads used in pavement markings must contain less than 200 ppm each of arsenic and lead when tested under EPA Test Method 3052 and 6010B or 6010C.

Replace the 1st paragraph in section 84-2.04 with:

01-20-12

A double extruded thermoplastic traffic stripe consisting of two 4-inch wide yellow stripes is measured as 2 traffic stripes.

A double sprayable thermoplastic traffic stripe consisting of two 4-inch wide yellow stripes is measured as 1 traffic stripe.

Add to section 84:

01-20-12

84-6 THERMOPLASTIC TRAFFIC STRIPES AND PAVEMENT MARKINGS WITH ENHANCED WET NIGHT VISIBILITY

Reserved

84-7-84-10 RESERVED

^^

86 ELECTRICAL SYSTEMS

10-17-14

Replace the paragraphs in section 86-1.01 with:

07-19-13

Section 86 includes general specifications for constructing and rehabilitating electrical systems. Electrical systems must comply with the material and installation specifications in section 86-2. Section 86-3 includes specifications for constructing controller assemblies. Section 86-4 includes specifications for constructing traffic signal faces, programmed visibility signal faces, pedestrian signal faces, flashing beacons, ramp metering signs, and signal mounting assemblies. Section 86-5 includes specifications for constructing vehicle detectors and pedestrian push button assemblies. Section 86-6 includes specifications for constructing lighting systems. Section 86-7 includes specifications for constructing rehabilitating electrical equipment. Comply with Part 4 of the *California MUTCD*. Nothing in section 86 is to be construed as to reduce the minimum standards in this manual. The locations shown for electrical systems are approximate; the Engineer determines the final locations.

Replace the paragraphs in section 86-1.015 with:

07-19-13

- actuation:** Actuation as defined in the *California MUTCD*.
- channel:** Discrete information path.
- controller assembly:** Assembly for controlling a system's operations, consisting of a controller unit and auxiliary equipment housed in a rainproof cabinet.
- controller unit:** Part of the controller assembly performing the basic timing and logic functions.
- detector:** Detector as defined in the *California MUTCD*.
- electrolier:** Assembly of a lighting standard and luminaire.
- flasher:** Device for opening and closing signal circuits at a repetitive rate.

flashing beacon control assembly: Assembly of switches, circuit breakers, terminal blocks, flasher, wiring, and other necessary electrical components housed in a single enclosure for operating a beacon.

inductive loop detector: Detector capable of being actuated by an inductance change caused by a vehicle passing or standing over the loop.

lighting standard: Pole and mast arm supporting the luminaire.

luminaire: Assembly that houses the light source and controls the light emitted from the light source.

magnetic detector: Detector capable of being actuated by an induced voltage caused by a vehicle passing through the earth's magnetic field.

powder coating: Coating applied electrostatically using exterior-grade UV-stable polymer powder.

pretimed controller assembly: Assembly operating traffic signals under a predetermined cycle length.

pull box: A box with a cover that is installed in an accessible place in a run of conduit to facilitate the pulling in of wires or cables.

signal face: Signal face as defined in the *California MUTCD*.

signal head: Signal head as defined in the *California MUTCD*.

signal indication: Signal indication as defined in the *California MUTCD*.

signal section: Signal section as defined in the *California MUTCD*.

signal standard: Pole and mast arm supporting 1 or more signal faces with or without a luminaire mast arm.

traffic-actuated controller assembly: Assembly for operating traffic signals under the varying demands of traffic as registered by detector actuation.

traffic phase: Signal phase as defined in the *California MUTCD*.

vehicle: Vehicle as defined in the *California Vehicle Code*.

Replace the paragraphs in section 86-1.02 with:

07-19-13

Comply with 8 CA Code of Regs § 2299 et seq.

Electrical equipment must comply with one or more of the following standards:

1. ANSI
2. ASTM
3. EIA
4. NEMA
5. NETA
6. UL
7. Public Utilities Commission, General Order No. 95, "Rules for Overhead Electrical Sign Construction"
8. Public Utilities Commission, General Order No. 128, "Rules for Construction of Underground Electric Supply and Communication Systems"

Materials and workmanship must comply with:

1. FCC rules
2. ITE standards
3. NEC
4. California Electrical Code

Electrical equipment and materials must be NRTL certified wherever applicable.

Replace the paragraphs in section 86-1.03 with:

07-19-13

Submit a schedule of values within 15 days after Contract approval.

Determine the quantities required to complete the work. Submit the quantities as part of the schedule of values.

Provide a schedule of values for each lump sum bid item.

Do not include costs for the traffic control system in the schedule of values.

The schedule of values must include the type, size, and installation method for:

1. Foundations
2. Standards and poles
3. Conduit
4. Pull boxes
5. Conductors and cables
6. Service equipment enclosures
7. Telephone demarcation cabinets
8. Vehicle signal heads and hardware
9. Pedestrian signal heads and hardware
10. Push buttons
11. Loop detectors
12. Luminaires and lighting fixtures
13. Materials shown in the quantity tables on plan sheets labeled *E*

Replace the paragraphs in section 86-1.04 with:

07-19-13

Within 15 days of Contract approval, submit a list of equipment and materials that you propose to install. Submit the list before shipping equipment or materials to the job site. The list must include the following information:

1. Manufacturer's name
2. Make and model number
3. Month and year of manufacture

4. Lot and serial numbers
5. Dimensions
6. List of components
7. Manufacturer's installation instructions
8. Contract number
9. Your contact information

Supplement the list with 2 copies of the following data:

1. Schematic wiring diagrams
2. Scale drawings of cabinets showing location and spacing of shelves, terminal blocks, and equipment, including dimensions
3. Operation manual

Electrical equipment constructed as shown does not require detailed drawings and diagrams.

Submit 3 sets of computer-generated schematic wiring diagrams for the cabinet.

Place the schematic wiring diagram in a heavy-duty plastic envelope and attach it to the inside of the cabinet door.

Prepare diagrams, plans, and drawings using graphic symbols in IEEE 315, "Graphic Symbols for Electrical and Electronic Diagrams."

Replace the 5th paragraph of section 86-2.04B(2) with:

07-19-13

HS bolts, nuts, and flat washers used to connect slip base plates must comply with the requirements for HS fastener assemblies for use in structural steel joints in section 55-1.02A(1) except rotational capacity testing and tension testing are not required.

07-19-13

Delete the row for standard Type 36-20A in the table in the 6th paragraph of section 86-2.04B(2).

Replace the 10th paragraph of section 86-2.04B(2) with:

07-19-13

Bolted connections attaching signal or luminaire arm to the pole must be considered slip critical. Galvanized faying surfaces of plates on luminaire arm, signal arm, and pole must be roughened by hand using a wire brush before assembly and must comply with requirements for Class C surface conditions for slip-critical connections in *Specification for Structural Joints Using High-Strength Bolts* of the RCSC. Coatings for faying surfaces must comply with the RCSC specification for Class B coatings.

Replace the 1st sentence of item 8 in the list in the 1st paragraph of section 86-2.04B(3) with:

07-19-13

During manufacturing, longitudinal seams on vertical tubular members of cantilevered support structures must be within 90 degrees circumferentially of the center of the longest mast arm connection.

07-19-13

Delete item 15.3 in the list in the 1st paragraph of section 86-2.04B(3).

Add between "Exposed" and "conduit" in the 2nd paragraph of section 86-2.05B:

07-19-13

Type 1

Replace the 1st sentence of the 10th paragraph of section 86-2.05C with:

07-19-13

After installing conduit, install the pull tape.

Replace the 1st sentence of the 15th paragraph of section 86-2.05C with:

11-15-13

Conduit runs shown to be located behind curbs may be installed in the street within 3 feet of and parallel to the face of the curb by the trenching in pavement method.

Replace the 1st and 2nd sentences of the 2nd paragraph of section 86-2.05D with:

07-19-13

Install an expansion-deflection fitting for expansion joints with a 1-1/2-inch movement rating. The fitting must be watertight and include a molded neoprene sleeve, a bonding jumper, and 2 silicon bronze or zinc-plated iron hubs.

Replace section 86-2.06 with:

07-19-13

86-2.06 PULL BOXES

86-2.06A General

86-2.06A(1) Cover Marking

The cover marking must be clearly defined, uniform in depth, and parallel to either the long or short sides of the cover.

Marking letters must be 1 to 3 inches high.

Before galvanizing steel or cast iron cover, apply marking by one of the following methods:

1. Use cast iron strip at least 1/4 inch thick with letters raised a minimum of 1/16 inch. Fasten strip to cover with 1/4-inch flathead stainless steel machine bolts and nuts. Peen bolts after tightening.
2. Use sheet steel strip at least 0.027 inch thick with letters raised a minimum of 1/16 inch. Fasten strip to cover by spot welding, tack welding, or brazing, with 1/4-inch stainless steel rivets or 1/4-inch roundhead stainless steel machine bolts and nuts. Peen bolts after tightening.
3. Bead weld the letters on cover such that the letters are raised a minimum of 3/32 inch.

86-2.06A(2) Installation and Use

Space pull boxes no more than 200 feet apart. You may install additional pull boxes to facilitate the work.

You may use a larger standard size pull box than that shown on the plans or specified.

A pull box in ground or sidewalk area must be installed as follows:

1. Embed bottom of the pull box in crushed rock.
2. Place a layer of roofing paper on the crushed rock.
3. Place grout over the layer of roofing paper. Grout must be 0.50 to 1 inch thick and sloped toward the drain hole.
4. Make a 1-inch drain hole in the center of the pull box through the grout and roofing paper.
5. Place grout between the pull box and the pull box extension, and around conduits.

The top of the pull box must be flush with the surrounding grade or the top of an adjacent curb, except in unpaved areas where the pull box is not immediately adjacent to and protected by a concrete foundation, pole, or other protective construction. Place the pull box 1-1/4 inches above the surrounding grade. Where practical, place a pull box shown in the vicinity of curbs or adjacent to a standard on the side of the foundation facing away from traffic. If a pull box is installed in a sidewalk area, adjust the depth of the pull box so that the top of the pull box is flush with the sidewalk.

Reconstruct the sump of an existing pull box if disturbed by your activities. Remove old grout and replace with new if the sump was grouted.

86-2.06B Non-Traffic Pull Boxes

Reserved

86-2.06C Traffic Pull Boxes

The traffic pull box and cover must comply with ASTM C857, "Standard Practice for Minimum Structural Design Loading for Underground Precast Concrete Utility Structures," for HS20 loading. You must be able to place the load anywhere on the box and cover for 1 minute without causing cracks or permanent deformations.

Frame must be anchored to the box with 1/4 by 2-1/4 inch concrete anchors. Four concrete anchors must be included for No. 3-1/2(T) pull box; one placed in each corner. Six concrete anchors must be included for No. 5(T) and No. 6(T) pull boxes; one placed in each corner and one near the middle of each of the longer sides.

Nuts must be zinc-plated carbon steel, vibration resistant, and have a wedge ramp at the root of the thread.

After installation of traffic pull box, install the steel cover and keep it bolted down when your activities are not in progress at the pull box. When the steel cover is placed for the final time, the cover and Z bar frame must be cleaned of debris and tightened securely.

Steel cover must be countersunk approximately 1/4 inch to accommodate the bolt head. When tightened, the bolt head must not exceed more than 1/8 inch above the top of the cover.

Concrete placed around and under traffic pull boxes must be minor concrete.

Replace the 11th row in the table in the 1st paragraph of section 86-2.08B with:

07-19-13

Grounded circuit conductor	Pedestrian push buttons	Wht	Blk	NBR	14
	Signals and multiple lighting	Wht	None	NBR	10
	Flashing beacons and sign lighting	Wht	None	NBR	12
	Lighting control	Wht	None	C-3	14
	Service	Wht	None	NBR	14

Replace the 1st sentence of the 1st paragraph of section 86-2.08C with:

07-19-13

Circuit conductors, connectors, and terminals must be UL or NRTL listed and rated for 600 V(ac) operation.

Add to the beginning of section 86-2.09A:

07-19-13

Provide enough traffic signal light conductors for functional operation of the signal. Provide 3 spare conductors in all conduits containing traffic signal light conductors.

Replace the paragraphs in section 86-2.09C with:

07-19-13

Connectors must be crimp type. Use a manufacturer-recommended tool for connectors and terminals to join conductors. Comply with SAE-AS7928.

Terminate stranded conductors smaller than no. 14 in crimp style terminal lugs.

Terminate field conductors no. 12 and smaller with spade type terminals. Terminate field conductors no. 10 and larger with spade type or ring type terminals.

Replace the value for resistivity in the table in the 6th paragraph of section 86-2.09E with:

07-19-13

25 x 10¹³ Ω per inch, minimum

Add between "the" and "head" in the 3rd sentence of the 2nd paragraph of 86-2.09F:

07-19-13

connector

Replace "project" in the 3rd paragraph of section 86-2.11A with:

10-19-12

work

Replace "Contract" in item 2 in the list in the 11th paragraph of section 86-2.11A with:

10-19-12

work

07-19-13

Delete the 12th paragraph of section 86-2.11A.

Replace section 86-2.11C with:

07-19-13

86-2.11C Electrical Service for Booster Pumps

Provide electrical service from the service point to the booster pump.

Furnish conductors, conduit, and pull boxes from the service point to the booster pump.

Do not use Type 3 conduit unless shown otherwise.

Replace section 86-2.14A with:

07-19-13

86-2.14A General

Deliver material and equipment for acceptance testing to either METS or a testing location as ordered.

Allow 30 days for testing. The Department notifies you when testing is complete. You must pick up the material or equipment from the test site and deliver it to the job site.

If material or equipment is rejected, allow 30 days for retesting. The retesting period starts when replacement material or equipment is delivered to the test site.

If material or equipment submitted for testing does not comply with the specifications, remove it within 5 business days after you are notified that the equipment is rejected. If equipment is not removed within that period, the Department may ship it to you and deduct the shipping cost.

Testing and quality control procedures for traffic signal controller assemblies must comply with NEMA TS standards for traffic control systems.

Replace the 2nd paragraph of section 86-3.02A(1) with:

07-19-13

The Department furnishes the BBS components under section 6-2.03.

Replace the 9th paragraph of section 86-3.02B with:

07-19-13

The couplings between the external cabinet and Model 332L cabinet must include a conduit for power connections between the 2 cabinets. Couplings must include:

1. 2-inch nylon-insulated steel chase nipple
2. 2-inch sealing steel locknut
3. 2-inch nylon-insulated steel bushing

07-19-13

Delete item 1.3 in the list in the 7th paragraph of section 86-3.04A.

Replace the 2nd paragraph of section 86-4.01A with:

07-19-13

The housing must not fail structurally as described in the following table:

Housing Structural Failure

Housing type	Test method	Description of structural failure
Metal	California Test 666	Fracture within the housing assembly or deflection of more than half the lens diameter of the signal section during the wind load test
Plastic	California Test 605	Fracture within the housing assembly or deflection of more than 10 degrees in either the vertical or horizontal plane after the wind load has been removed from the front of the signal face or deflection of more than 6 degrees in either the vertical or horizontal plane after the wind load has been removed from the back of the signal face

Replace the 1st sentence of section 86-4.01A(1) with:

07-19-13

Each metal housing must have a metal visor.

Replace the 1st sentence of section 86-4.01A(2) with:

07-19-13

Each plastic housing must be molded in 1 piece or fabricated from 2 or more pieces and joined into a single piece.

07-19-13

Delete item 1 in the list in section 86-4.01D(1)(b).

Replace the paragraphs in section 86-4.01D(1)(c)(i) with:

07-19-13

LED signal modules must be on the Authorized Material List for LED traffic signals.

The Department tests modules under section 86-2.14A, ANSI/ASQ Z1.4, and:

1. California Test 604 for LED and circular LED signal modules
2. California Test 3001 for arrow, U-turn, and bicycle LED signal modules

The LED signal modules submitted for testing must be typical production units. LEDs must be spread evenly across the module.

The Department may test the modules on all parameters specified in section 86-4.01D.

Replace the 1st and 2nd sentences of the 3rd paragraph of 86-4.01D(2)(b) with:

07-19-13

The electrical connection for each flashing LED signal module must be 4 secured, color-coded, jacketed copper wires. The wire must comply with the NEC.

Replace the heading of section 86-4.02 with:

07-19-13

PROGRAMMED VISIBILITY VEHICLE SIGNAL SECTION

Replace "face" in the 1st paragraph of section 86-4.02 with:

07-19-13

section

Add before the 1st sentence in section 86-4.03A:

07-19-13

The pedestrian signal face must be Type A.

Replace the 1st sentence of the 2nd paragraph of section 86-4.03B with:

07-19-13

The Department tests the pedestrian signal's front screen in a horizontal position with its edges supported.

07-19-13

Delete items 1 and 4 in the list in section 86-4.03I(1)(b).

Replace the paragraphs of section 86-4.03I(1)(c)(i) with:

07-19-13

The LED PSF module must be on the Authorized Material List for LED traffic signals.

The Department tests LED PSF modules under section 86-2.14A, ANSI/ASQ Z1.4, and California Test 606.

The LED PSF modules submitted for testing must be representative of typical production units.

The Department may test the modules on all parameters specified in section 86-4.03I.

Replace item 1 in the list in the 1st paragraph of section 86-4.03I(2) with:

07-19-13

1. Not include reflectors.

Replace item 6 in the list in the 1st paragraph of section 86-4.03I(2) with:

07-19-13

- 6. Be able to replace signal lamp optical units and pedestrian signal faces with LEDs.

Replace the table titled "Chromaticity Standards (CIE Chart)" in the 16th paragraph of section 86-4.03I(2) with:

07-19-13

Chromaticity Standards (CIE Chart)

Upraised hand	X: not greater than 0.659 or less than 0.600 Y: not greater than 0.390 or less than 0.331 Y= 0.990-X
Walking person	X: not greater than 0.440 or less than 0.280 Y: not greater than 0.0483 + 0.7917(X) or less than 0.0983 + 0.7917(X)

Replace the paragraphs in section 86-4.03J with:

10-17-14

Reserved

Add between "beacon" and "must" in the 1st sentence of section 86-4.05:

07-19-13

signal face

07-19-13

Delete "face" in item 1 in the list in the 1st paragraph of section 86-4.05.

Replace the row for viscosity in the table in the 2nd paragraph of section 86-5.01A(3)(c) with:

07-19-13

Viscosity, Brookfield Thermosel, no. 27 Spindle, 20 rpm, 190 °C	D 4402	2.5–3.5 Pa·s
--	--------	--------------

Replace the paragraph in section 86-5.01A(3)(d) with:

07-19-13

Use epoxy sealant for repair work in and around sawcuts housing inductive loops.

Replace "all loop conductors" in the 3rd paragraph of section 86-5.01A(4) with:

07-19-13

the detector lead-in cable

Replace "Encase the loop wires" in the 1st sentence of the 3rd paragraph of section 86-5.01A(5) with:

07-19-13

The loop wires must be encased

Replace section 86-5.02 with:

07-19-13

86-5.02 PUSH BUTTON ASSEMBLIES

The housing for a push button assembly must be die-cast or permanent mold-cast aluminum. The assembly must be rainproof and shockproof in any weather condition.

The push button's switch must be a single-pole, double-throw switching unit with screw-type terminals rated 15 A at 125 V(ac). The switch must have:

1. Plunger actuator and a U frame to allow recessed mounting in the push button housing
2. Operating force of 3.5 lb
3. Maximum pretravel of 5/64 inch
4. Minimum overtravel of 1/32 inch
5. Differential travel from 0.002 to 0.04 inch
6. 2-inch minimum diameter actuator

Where a push button is attached to a pole, the housing must be shaped to fit the pole's curvature. Use saddles if needed to make a neat and secure fit.

Where a push button is mounted on top of a 2-1/2-inch-diameter post, fit the housing with a slip fitter and use screws to rigidly secure it to the post.

Install the push button and the sign on the crosswalk side of the pole.

Attach the sign on a Type B push button assembly.

For a Type C push button assembly, mount the instruction sign on the same standard as the assembly using 2 straps and saddle brackets.

Add to section 86-5:

07-19-13

86-5.03 ACCESSIBLE PEDESTRIAN SIGNAL

Reserved

Replace "lthe amp" in item 2 in the list in the 1st paragraph of section 86-6.01A(2) with:

07-19-13

the lamp

^^

DIVISION X MATERIALS

88 GEOSYNTHETICS

07-19-13

Add to section 88-1.01C:

07-19-13

Geosynthetics must be on the DataMine list for geotextiles and geosynthetics at the National Transportation Product Evaluation Program Web site. The product name, manufacturing source, and date of manufacture must be printed every 5 meters along the edge of the material.

Exceptions are:

- 1. Paving mat
- 2. Paving grid, Class 2 and 3
- 3. Biaxial geogrid

Replace the row for hydraulic bursting strength in the table in the 2nd paragraph of section 88-1.02B with:

10-19-12

Puncture strength, lb min	ASTM D 6241	310
Trapezoid tearing strength, lb min	ASTM D 4533	56

Replace the 3rd paragraph in section 88-1.02C with:

10-19-12

Geocomposite wall drain must be from 0.25 to 2 inches thick.

Replace the value for permittivity of woven fabric in the table in the 1st paragraph of section 88-1.02E with:

01-20-12

0.05

Replace the value for apparent size opening of nonwoven fabric in the table in the 1st paragraph of section 88-1.02E with:

01-20-12

0.012

Replace the table in the 1st paragraph of section 88-1.02G with:

01-20-12

Sediment Filter Bag

Property	Test	Values	
		Woven	Nonwoven
Grab breaking load, lb, 1-inch grip min, in each direction	ASTM D 4632	200	250
Apparent elongation, percent min, in each direction	ASTM D 4632	10	50
Water flow rate, gal per minute/sq ft min and max average roll value	ASTM D 4491	100-200	75-200
Permittivity, sec ⁻¹ min	ASTM D 4491	1.0	1.0
Apparent opening size, inches max average roll value	ASTM D 4751	0.023	0.012
Ultraviolet resistance, % min retained grab breaking load, 500 hr.	ASTM D 4355	70	70

Replace the table in the 1st paragraph of section 88-1.02H with:

01-20-12

Temporary Cover

Property	Test	Values	
		Woven	Nonwoven
Grab breaking load, lb, 1-inch grip min, in each direction	ASTM D 4632	200	200
Apparent elongation, percent min, in each direction	ASTM D 4632	15	50
Water flow rate, gal per minute/sq ft min and max average roll value	ASTM D 4491	4-10	80-120
Permittivity, sec ⁻¹ min	ASTM D 4491	0.05	1.0
Apparent opening size, inches max average roll value	ASTM D 4751	0.023	0.012
Ultraviolet resistance, % min retained grab breaking load, 500 hr.	ASTM D 4355	70	70

Replace section 88-1.02P with:

01-18-13

88-1.02P Biaxial Geogrid

Geosynthetics used for biaxial geogrid must be a punched and drawn polypropylene material formed into an integrally formed biaxial grid. When tested under the referenced test methods, properties of biaxial geogrid must have the values shown in the following table:

Biaxial Geogrid

Property	Test	Value
Aperture size, inch ^a min and max	Calipered	0.8-1.3 x 1.0-1.6
Rib thickness, inch min	Calipered	0.04
Junction thickness, inch min	Calipered	0.150
Tensile strength, 2% strain, lb/ft ^a min	ASTM D 6637	410 x 620
Tensile strength at ultimate, lb/ft ^a min	ASTM D 6637	1,310 x 1,970
Ultraviolet resistance, percent min retained tensile strength, 500 hours	ASTM D 4355	100
Junction strength, lb/ft ^a min	ASTM D 7737	1,220 x 1,830
Overall flexural rigidity, mg-cm min	ASTM D 7748	750,000
Torsional rigidity at 20 cm-kg, mm-kg/deg ^b min	GRI:GG9	0.65

^aMachine direction x cross direction

^bGeosynthetic Research Institute, Test Method GG9, *Torsional Behavior of Bidirectional Geogrids When Subjected to In-Plane Rotation*

Replace section 88-1.02Q with:

07-19-13

88-1.02Q Geosynthetic Bond Breaker

Geosynthetic bond breaker must be nonwoven; needle punched; not heat treated; polypropylene, polyethylene material.

When tested under the referenced test methods, properties of geosynthetic bond breaker material must have the values shown in the following table:

Replace the paragraphs in section 90-4.01C with:

07-19-13

90-4.01C(1) General

For reports and logs, type or clearly print the name next to the signature of the person signing the report or log.

Submit expansion test data under section 90-4.02, if required.

90-4.01C(2) Certificates of Compliance

Submit a certificate of compliance for the cementitious material used in PC concrete members. The certificate must be signed by the PC concrete product manufacturer.

Submit a certificate of compliance for each PC concrete member. The certificate of compliance for tier 1 and tier 2 members must be signed by the QC manager. The certificate of compliance for tier 3 members must be signed by the QC Inspector.

90-4.01C(3) Precast Concrete Quality Control Plan

Before performing any precasting activities for tier 1 and tier 2 PC concrete members, submit 3 copies of the project-specific QC plan for the PC plant. The QC plan must supplement the information from the authorized facility audit. Submit a separate QC plan for each plant. Allow 25 days for review.

Each project-specific QC plan must include:

1. Name of the precasting plant, concrete plants, and any testing laboratory to be used.
2. Manual prepared by the precasting plant that includes:
 - 2.1. Equipment description
 - 2.2. Testing procedures
 - 2.3. Safety plan
 - 2.4. Personnel names, qualifications, and copies of certifications
3. QC manager and QC inspector names, qualifications, and copies of certifications.
4. Organizational chart showing QC personnel and their assigned QC responsibilities.
5. Methods and frequencies for performing QC procedures including inspections, material testing, and any survey performed for all components of PC concrete members. Components include prestressing, concrete, grout, reinforcement, steel, miscellaneous metal, and formwork.
6. System for reporting noncompliant PC concrete members to the Engineer.
7. System for identification and tracking repairs and repair methods.
8. Procedure for the reinspection of repaired PC concrete members.
9. Forms for certificates of compliance, daily production logs, and daily reports.

Submit a revised QC plan for any changes to:

1. Concrete plants
2. Material sources
3. Material testing procedures
4. Testing laboratory

5. Procedures and equipment
6. Updated systems for tracking and identifying PC concrete members
7. QC personnel

After authorization, submit 7 copies of each authorized QC plan and make 1 copy available at each location where work is performed.

Allow 7 days for review of a revised QC plan.

90-4.01C(4) Daily Production Log

The QC inspector must provide reports to the QC manager for each day that precasting activities are performed.

The QC manager must maintain a daily production log of PC activities for each day's precasting. PC activities include setting forms, placing reinforcement, setting prestressing steel, casting, curing, post tensioning, and form release. This daily log must be available at the precasting plant. The daily log must include:

1. Plant location
2. Specific description of casting or related activities
3. Any problems or deficiencies discovered
4. Any testing or repair work performed
5. Names of QC inspectors and the specific QC inspections they performed that day
6. Reports for that day's precasting activities from each QC inspector including before, during, and after precast inspections

Immediately notify the Engineer when any precasting problems or deficiencies are discovered, and submit the proposed repair or process changes necessary to correct them.

90-4.01C(5) Precast Concrete Report

Before shipping PC concrete members, submit a PC concrete report. The report must include:

1. Reports of all material tests and any survey checks
2. Documentation that:
 - 2.1. You have evaluated all tests
 - 2.2. You corrected all rejected deficiencies
 - 2.3. Repairs have been reexamined with the required tests and found acceptable
3. Daily production logs
4. Certificates of compliance
5. Documentation of inspections

Each person who performs a material test or survey check must sign the corresponding report and submit the report directly to the QC manager.

Replace the paragraphs in section 90-4.01D with:

07-19-13

90-4.01D(1) General

Quality control and assurance for PC concrete includes:

1. Your QC program
2. Department's acceptance of PC concrete members

PC concrete members are categorized into the following 4 tiers:

1. Tier 1 consists of:
 - 1.1. Components of bridge structures, including girders, deck panels, bent caps, abutments, slabs, closure wall panels, and piling
 - 1.2. Prestressed pavement
2. Tier 2 consists of:
 - 2.1. Components of earth retaining systems
 - 2.2. Wingwalls
 - 2.3. Types A, B, and C pipe culvert headwalls, endwalls, and wingwalls
 - 2.4. Pavement
 - 2.5. Box culverts
 - 2.6. Sound wall panels and supports
3. Tier 3 consists of:
 - 3.1. Pipes
 - 3.2. Pipe drainage facilities
 - 3.3. Straight and "L" pipe culvert headwalls except those listed under tier 2
 - 3.4. Drainage Inlets
 - 3.5. Flared end sections
4. Tier 4 consists of any member not described as tier 1, tier 2, or tier 3

90-4.01D(2) Quality Control

90-4.01D(2)(a) General

For tier 1 and tier 2 PC concrete members:

1. Fabricate PC concrete members at a plant on the Authorized Facility Audit List
2. Assign a PC concrete QC manager to the plant
3. Assign a QC inspector who is either registered as a civil engineer in the State or:
 - 3.1. For tier 1, has a Plant Quality Personnel Level II certification from the Precast/Prestressed Concrete Institute
 - 3.2. For tier 2, has a Plant Quality Personnel Level I certification from the Precast/Prestressed Concrete Institute
4. Prepare a PC concrete QC plan

5. Perform PC concrete materials testing
6. Maintain a daily production log
7. Prepare a PC concrete report
8. Prepare a certificate of compliance

For tier 3 PC concrete members:

1. Assign a QC inspector who has one of the following qualifications:
 - 1.1. Registration as a civil engineer in the State.
 - 1.2. Plant Quality Personnel, Level I certification from the Precast/Prestressed Concrete Institute.
 - 1.3. Competency to perform inspection of PC operations. An inspector is competent if the individual has completed training or has experience in PC operations and inspection.
2. Prepare a certificate of compliance

For tier 4 PC concrete members, prepare a certificate of compliance.

For each ASTM test method specified in this section, the material's test result must comply with the requirement specified for the comparable test in section 90 unless otherwise specified.

If curing compound is used, provide certificate of compliance as specified in section 90-1.01C(5).

If PC concrete is manufactured at an established PC concrete plant, a trial batch and prequalification of the materials, mix proportions, mixing equipment, and procedures under section 90-1.01D(5)(b) are not required.

90-4.01D(2)(b) Quality Control Meeting

After submitting the PC concrete QC plan, hold a meeting to discuss the requirements for PC concrete QC. The meeting attendees must include the Engineer, the PC concrete QC manager, and a representative from each plant performing PC concrete activities for the Contract.

90-4.01D(2)(c) Sampling, Testing, and Inspecting

The QC laboratory testing personnel or the QC inspector must witness sampling. The QC laboratory testing personnel must perform testing.

QC laboratory testing personnel must have the following certifications, as applicable:

1. ACI Strength Testing Technician
2. ACI Concrete Laboratory Testing Technician Level 1
3. ACI Aggregate Testing Technician Level 2

The QC Inspector must perform inspections before, during, and after casting is complete.

QC field testing and inspection personnel must have an ACI Concrete Field Testing Technician, Grade I certification.

For each mix design used for tier 1 and tier 2 PC concrete members, perform sampling and testing at the minimum frequencies shown in the following tables:

Aggregate QC Tests

Property	Test method	Minimum testing frequency
Aggregate gradation	ASTM C136	Once per 400 cu yd of concrete cast or once a week, whichever is more frequent
Sand equivalent	ASTM D2419	
Percent fines under 75 microns ^a	ASTM C117	
Moisture content of fine aggregate	ASTM C566, or electronically actuated moisture meter ^b	1–2 times per each day of pour, depending on conditions

^aPercent fines under 75 microns test replaces the cleanness test in section 90-1.02C with the requirements of 1.5 percent maximum for "Operating Range" and 2.0 percent maximum for "Contract Compliance." The 5th paragraph of section 90-1.02C(2) does not apply.

^bElectronically actuated moisture meter must be calibrated once per week per ASTM C566.

Concrete QC Tests

Property	Test method	Minimum testing frequency
Compressive strength ^b	ASTM C172/C172M, ASTM C31/C31M, and ASTM C39/C39M	Once per 100 cu yd of concrete cast, or every day of casting, whichever is more frequent
Slump	ASTM C143/C143M	
Temperature	ASTM C1064/C1064M	
Density	ASTM C138	Once per 600 cu yd of concrete cast or each week of batching, whichever is more frequent
Air content	ASTM C231/C231M or ASTM C173/C173M ^a	If concrete is air entrained, once for each set of cylinders, and when conditions warrant

^aASTM C173/C173M must be used for lightweight concrete.

^bCylinders must be 6 by 12 inches.

If concrete is batched at more than 1 plant, perform the tests at each plant.

Cure test cylinders for determining time of prestressing loading in the same manner as the concrete in the member.

Cure test cylinders for determining compliance with 28-day strength requirements in the same manner as the member until completion of the steam curing process followed by a water bath or moist room at 60 to 80 degrees F until tested.

For PC concrete that is steam cured, concrete designated by compressive strength is acceptable if its compressive strength reaches the described 28-day compressive strength in no more than the maximum number of days specified or allowed after the concrete is cast.

90-4.01D(3) Quality Assurance

For PC concrete that is steam cured, the Engineer evaluates the compressive strength based on individual tests representing specific portions of production.

Add between the 1st and 2nd paragraphs of section 90-4.02:

07-19-13

PC portland cement based repair material must be on the Authorized Material List.

If municipally supplied potable water is used for PC concrete, the testing specified in section 90-1.02D is waived unless requested.

Add to section 90-4.03:

07-19-13

For dimensional tolerances of PC concrete members, comply with the Precast/Prestressed Concrete Institute Concrete Institute's *Tolerance Manual for Precast and Prestressed Concrete Construction, MNL 135-00*.

For tier 1 and tier 2 PC concrete members, apply curing compound using power-operated spraying equipment. You may request application by hand spraying for small quantities of PC concrete members. For tier 3 and tier 4 PC concrete members, the application of curing compound may be hand sprayed.

Replace the item 2 in the list in the 2nd paragraph of section 90-4.03 with:

07-19-13

- 2. To prevent moisture loss on the exposed surfaces during the presteaming period, cover the concrete as soon as possible after casting or keep the exposed surfaces wet by fog spray, curing compound, or wet blankets.

^^

91 PAINT

10-19-12

Add to section 91-2:

10-19-12

91-2.03 MOISTURE-CURED POLYURETHANE COATING

Reserved

Replace "saint" in the 1st paragraph of section 91-4.05 with:

10-19-12

paint

^^

92 ASPHALTS

07-19-13

Replace "Reserved" in section 92-1.01B with:

07-19-13

modified asphalt binder: Asphalt binder modified with polymers, crumb rubber, or both.

Replace the row for dynamic shear for original binder in the table in the 1st paragraph of section 92-1.02B with:

01-20-12

Dynamic shear,						
Test temperature at 10 rad/s, °C	T 315	58	64	64	64	70
min G*/sin(delta), kPa		1.00	1.00	1.00	1.00	1.00
max G*/sin(delta), kPa		2.00	2.00	2.00	2.00	2.00

Replace 2nd paragraph of section 92-1.02B with:

07-19-13

PG modified asphalt binder must comply with the requirements shown in the following table:

PG Modified Asphalt Binder				
Property	AASHTO Test Method	Grade		
		PG 58–34 M	PG 64–28 M	PG 76–22 M
Original Binder				
Flash point, min °C	T 48	230	230	230
Solubility, min %	T 44 ^a	97.5	97.5	97.5 ^b
Viscosity at 135 °C, max, Pa·s	T 316	3.0	3.0	3.0
Dynamic shear, Test temperature at 10 rad/s, °C min G*/sin(delta), kPa	T 315	58 1.00	64 1.00	76 1.00
RTFO test ^d , Mass loss, max, %	T 240	1.00	1.00	1.00
RTFO Test Aged Binder				
Dynamic shear, Test temperature at 10 rad/s, °C min G*/sin(delta), kPa	T 315	58 2.20	64 2.20	76 2.20
Dynamic shear, Test temperature at 10 rad/s, °C max (delta), degree	T 315	80 ^e	80 ^e	80 ^e
Elastic recovery ^f , Test temperature °C min recovery, %	T 301	25 75	25 75	25 65
PAV ^g , temperature, °C	R 28	100	100	110
RTFO Test and PAV Aged Binder				
Dynamic shear, Test temperature at 10 rad/s, °C max G*sin(delta), kPa	T 315	16 5000	22 5000	31 5000

Creep stiffness,				
Test temperature, °C	T 313	-24	-18	-12
max S-value, MPa		300	300	300
min M-value		0.300	0.300	0.300

^aThe Department allows ASTM D 5546 or ASTM D 7753 instead of AASHTO T 44. Particles recovered from ASTM D 5546 or ASTM D 7753 or AASHTO T 44 must be less than 250 µm.

^bReport only for spray application.

^cThe Engineer waives this specification if the supplier provides written certification the asphalt can be adequately pumped and mixed at temperatures meeting applicable safety standards.

^d"RTFO Test" means the asphaltic residue obtained using the Rolling Thin Film Oven Test, AASHTO Test Method T 240 or ASTM D 2872. The residue from mass change determination may be used for other tests.

^eTest temperature is the temperature at which G*/sin(delta) is 2.2 kPa. A graph of log G*/sin(delta) plotted against temperature may be used to determine the test temperature when G*/sin(delta) is 2.2 kPa. A graph of (delta) versus temperature may be used to determine delta at the temperature when G*/sin(delta) is 2.2 kPa. The graph must have at least two points that envelope G*/sin(delta) of 2.2 kPa and the test temperature must not be more than 6 degree C apart. The Engineer also accepts direct measurement of (delta) at the temperature when G*/sin(delta) is 2.2 kPa.

^fTests without a force ductility clamp may be performed.

^g"PAV" means "Pressure Aging Vessel."

Do not modify PG modified asphalt binder using polyphosphoric acid.

Crumb rubber must be from automobile and truck tires and must be free from contaminants including fabric, metal, minerals, and other nonrubber substances.

PG modified asphalt binder modified with crumb rubber must be homogeneous and must not contain visible particles of crumb rubber.

The supplier of PG modified asphalt binder modified with crumb rubber must:

1. Report the amount of crumb rubber by weight of asphalt binder
2. Certify a minimum of 10 percent of crumb rubber by weight of asphalt binder

^^

93 LIQUID ASPHALTS

07-19-13

Replace "Celsius" the 1st row in the table in the 8th paragraph of section 93-1.04 with:

07-19-13

Fahrenheit

APPENDIX B
NOTICE OF EXEMPTION

CEQA Notice of Exemption

To: County of El Dorado, Recorder-Clerk's Office
360 Fair Lane
Placerville, CA 95667

From: El Dorado County
Division of Transportation
2850 Fairlane Court
Placerville, CA 95667

Project Title: Patterson Drive and Missouri Flat Road Overlay Project (CIP #72190)

Project Location – Specific: This Project is located on Patterson Drive between Lake Oaks Drive and Solstice Circle; and on Missouri Flat Road from the Missouri Flat Road/Pleasant Valley Road (SR49) intersection north approximately 700 feet; in the Community of Diamond Springs, El Dorado County.

Project Location – City: Unincorporated

Project Location – County: El Dorado

Description of Project:

The Patterson Drive and Missouri Flat Road Overlay Project consists of an approximately 1.3 mile roadway maintenance project. The Project consists of cold planing the existing roadway surface, and installing a geo-composite pavement interlayer, along with a hot mix asphalt overlay, followed by thermoplastic pavement stripes and markings. Additionally, the County's contractor will perform signal modification work consisting of the placement of approximately 100 feet of electrical conduit, a pull box, loop detectors, and detector hand-holes at the Missouri Flat Road/Pleasant Valley Road (SR49) intersection. The project will require lane closures but no road closure is anticipated. The duration of construction activities is anticipated to be approximately 1 month (20 working days).

All work will take place within the existing County and State right of ways. No grading or vegetation removal will occur as a result of this project.

Name of Public Agency Approving Project: El Dorado County Community Development Agency, Transportation Division

Name of Person or Agency Carrying Out Project: El Dorado County Community Development Agency, Transportation Division

Exempt Status: *(check one)*

- Ministerial (Sec. 21080(b)(1); 15268);
- Declared Emergency (Sec. 21080(b)(3); 15269(a);
- Emergency Project (Sec. 21080(b)(4); 15269(b)(c));
- Categorical Exemption. State type and section number: Sec. 15301, Class I(c)

FILED

JAN 21 2016

WILLIAM E. SCHULTZ, Recorder-Clerk
Michelle Kuyper

Reasons why project is exempt:

The project consists of maintenance work on an existing roadway within the existing right of way. The project will not change or expand the existing use.

Lead Agency

Contact Person: Janet Postlewait, Principal Planner

Phone: 530-621-5993

Signature:



Date: 1-21-16

APPENDIX C

EXHIBITS

EXHIBIT A

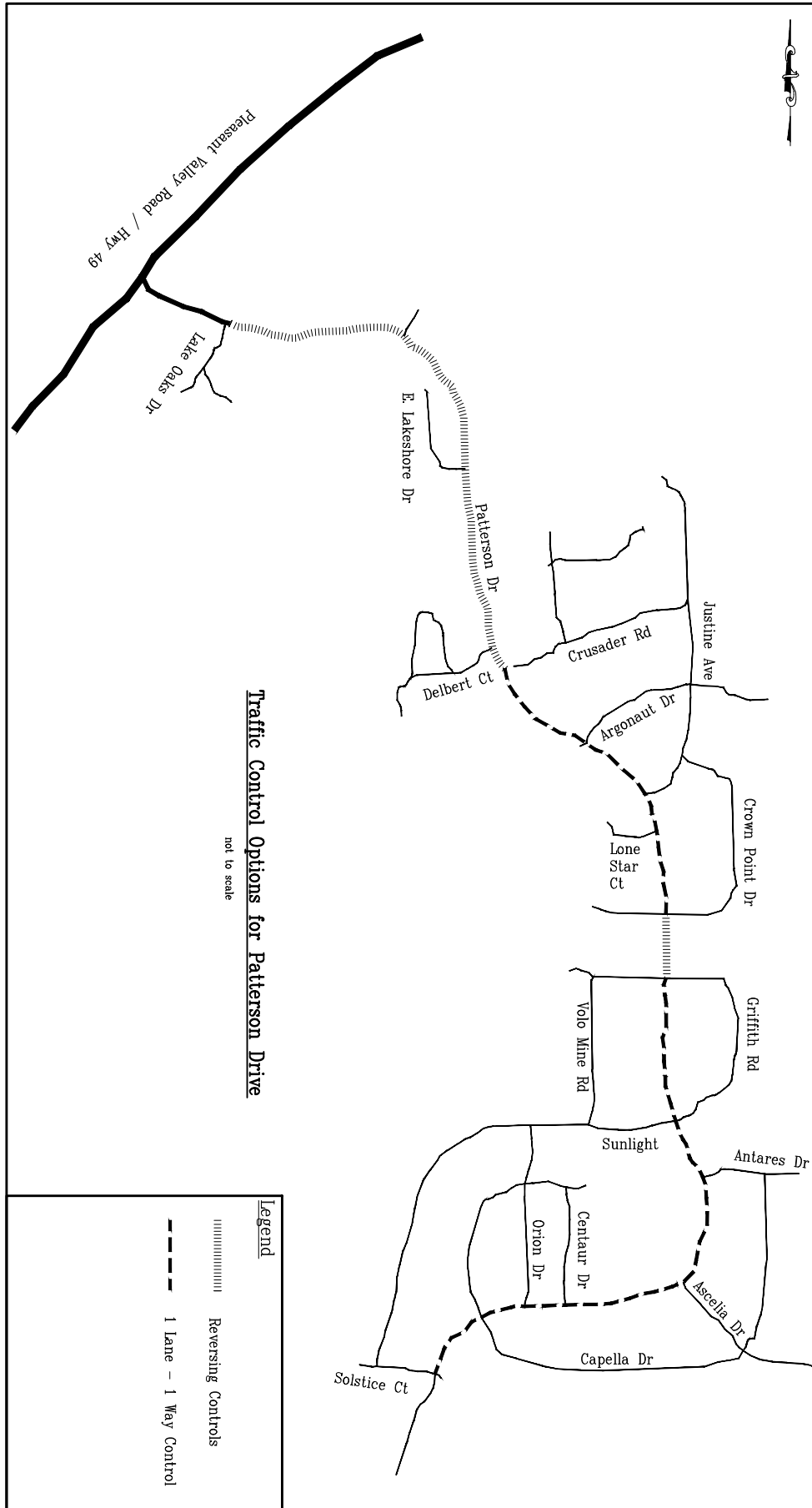

EXHIBIT B-1

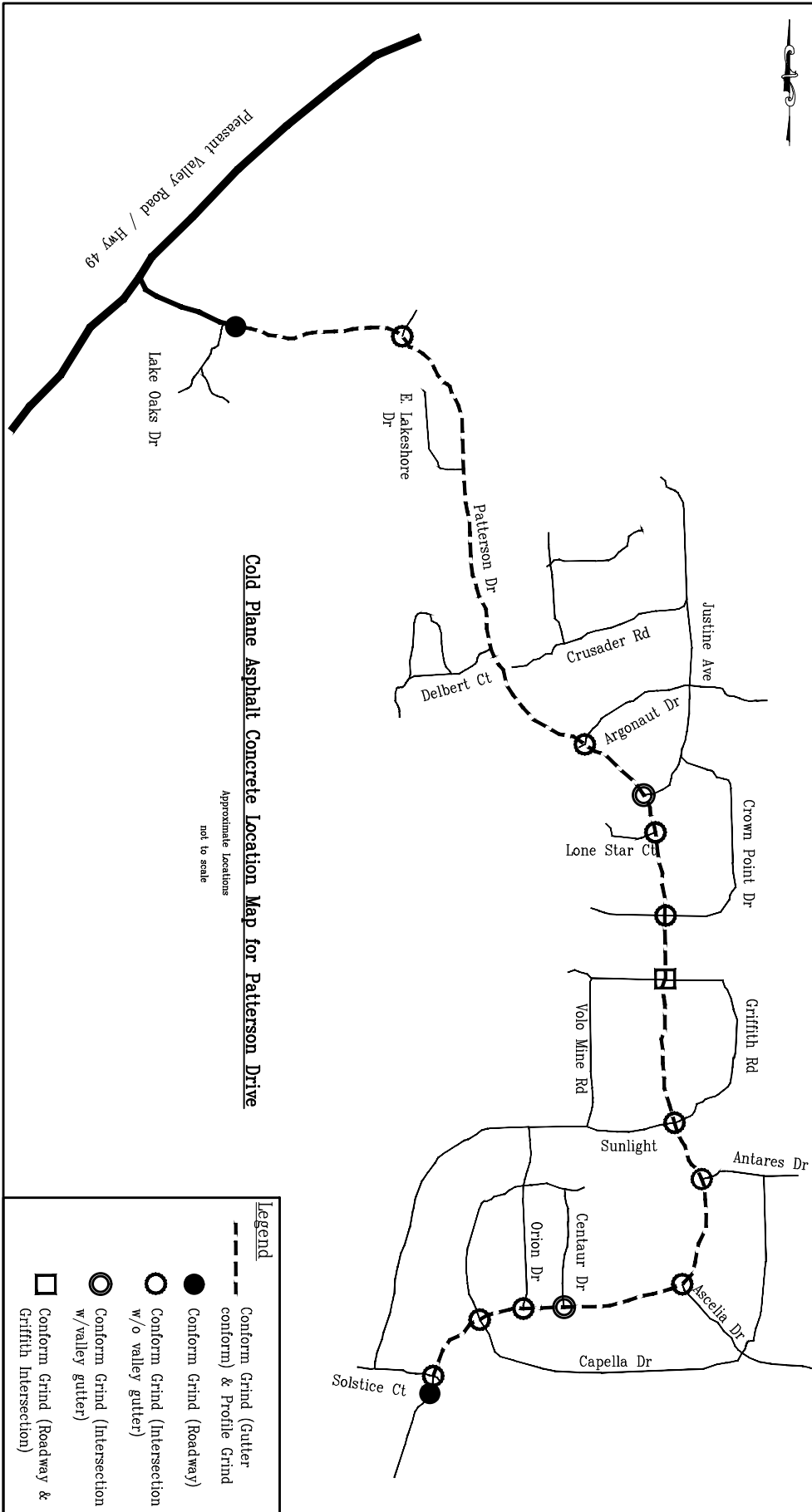

EXHIBIT B-2

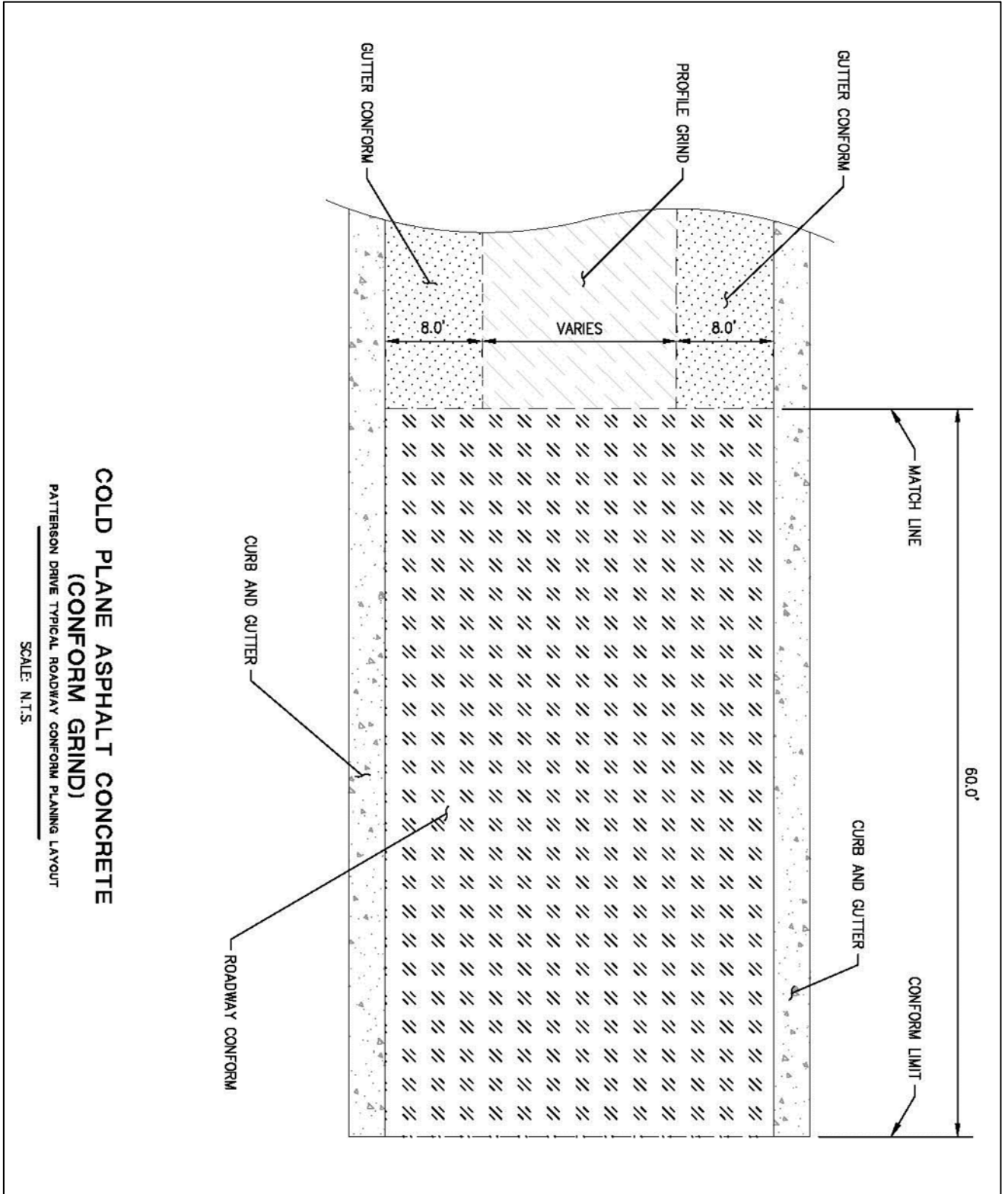

EXHIBIT B-3

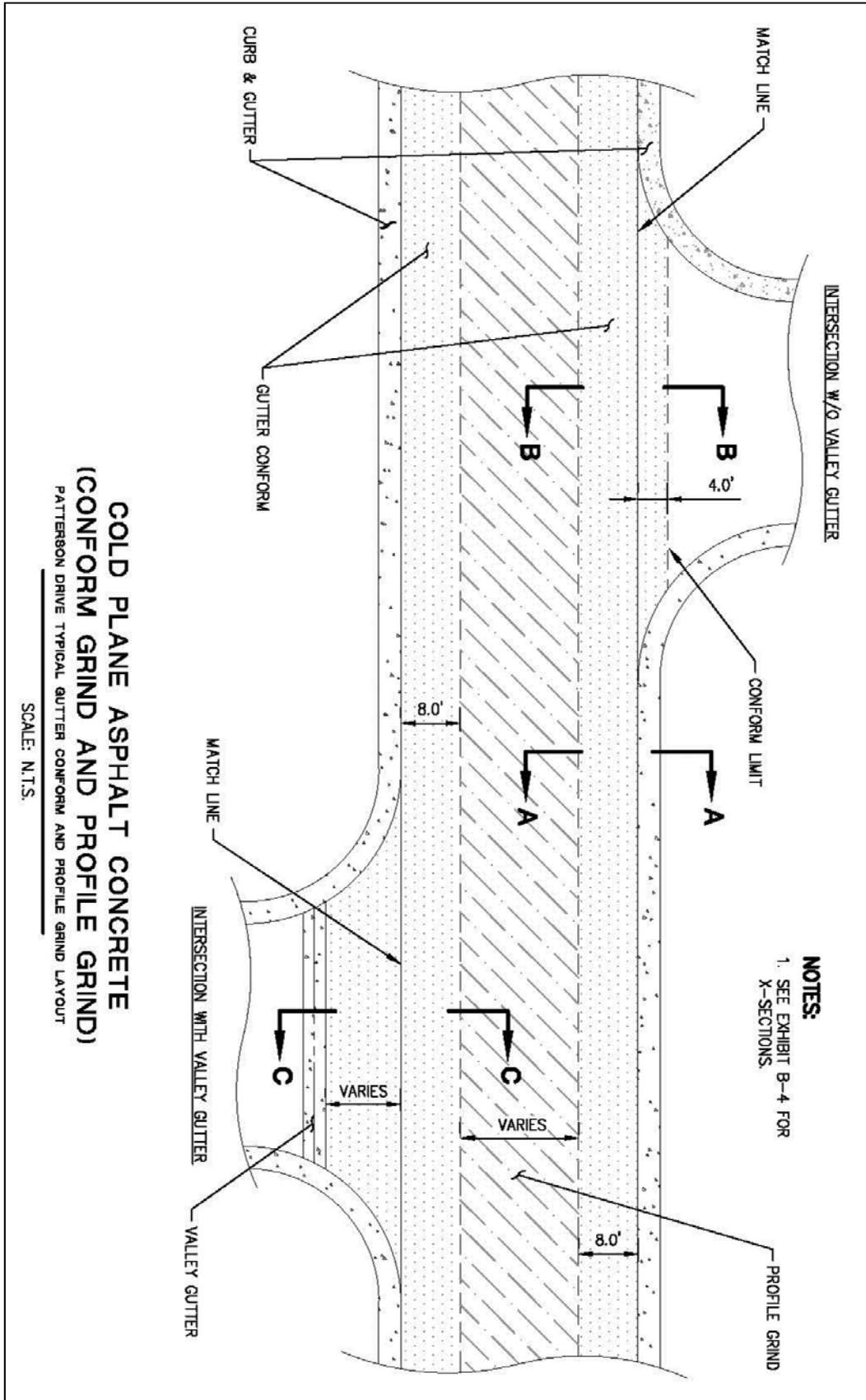

EXHIBIT B-4

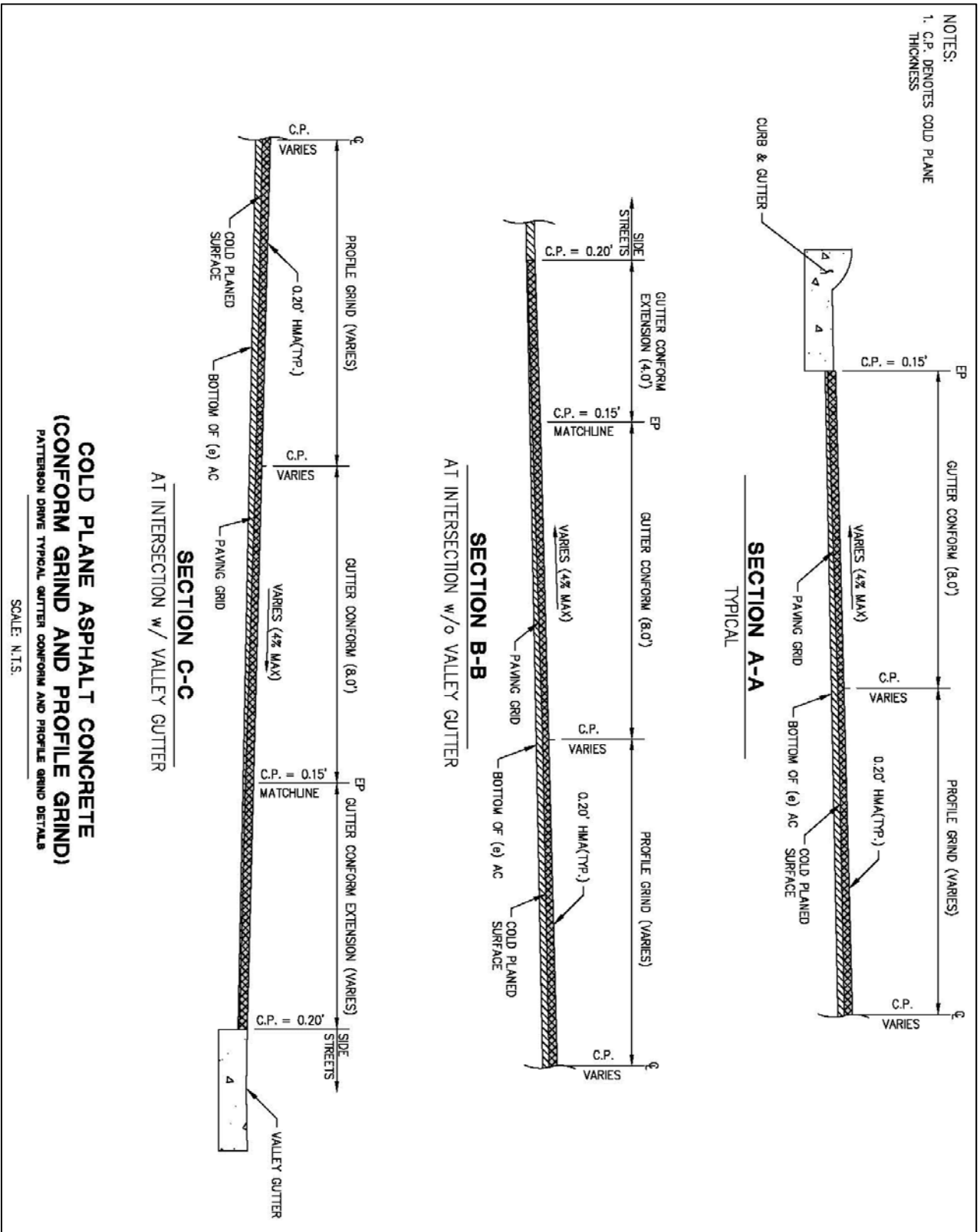

EXHIBIT B-5

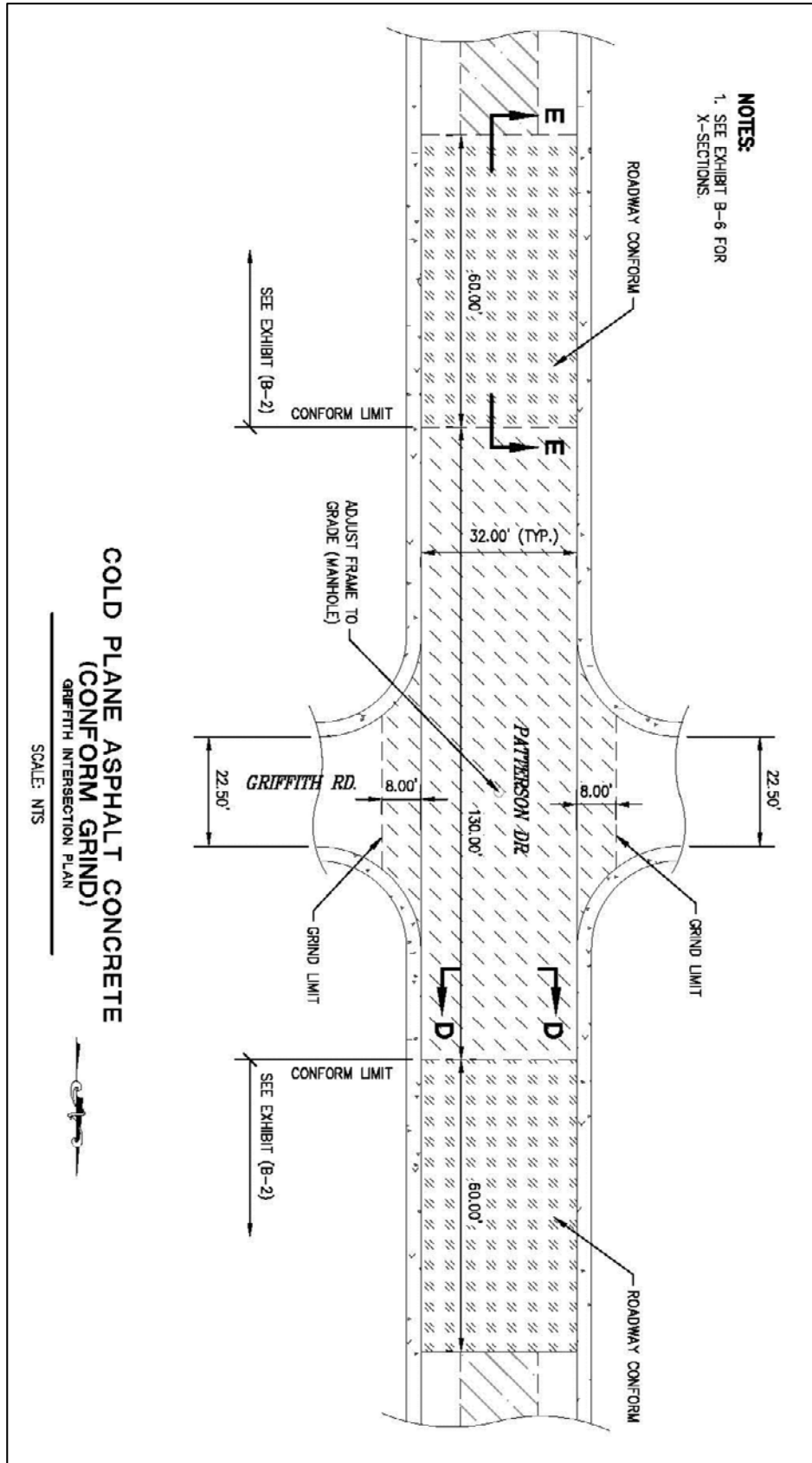

EXHIBIT B-6

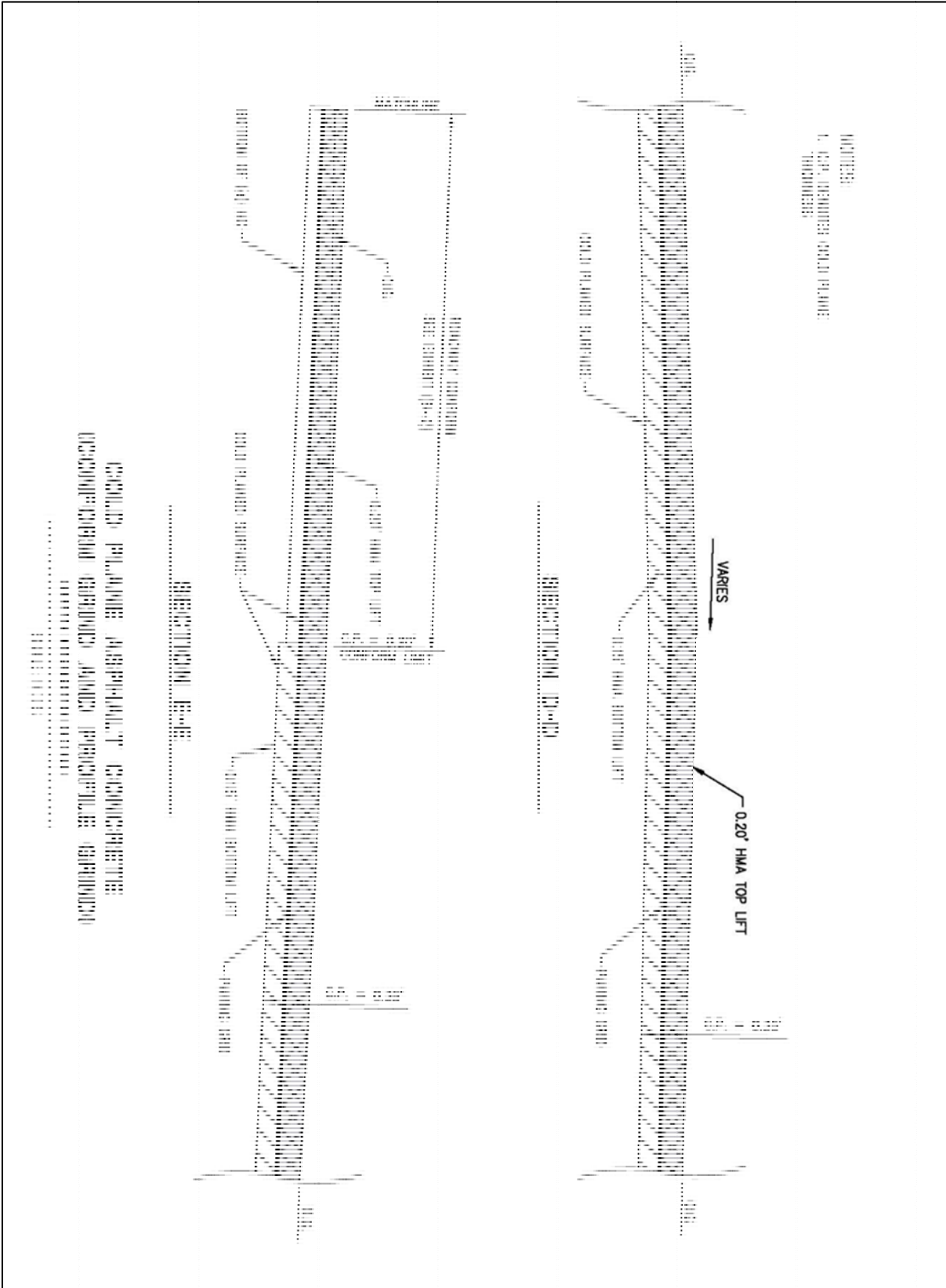

EXHIBIT B-7

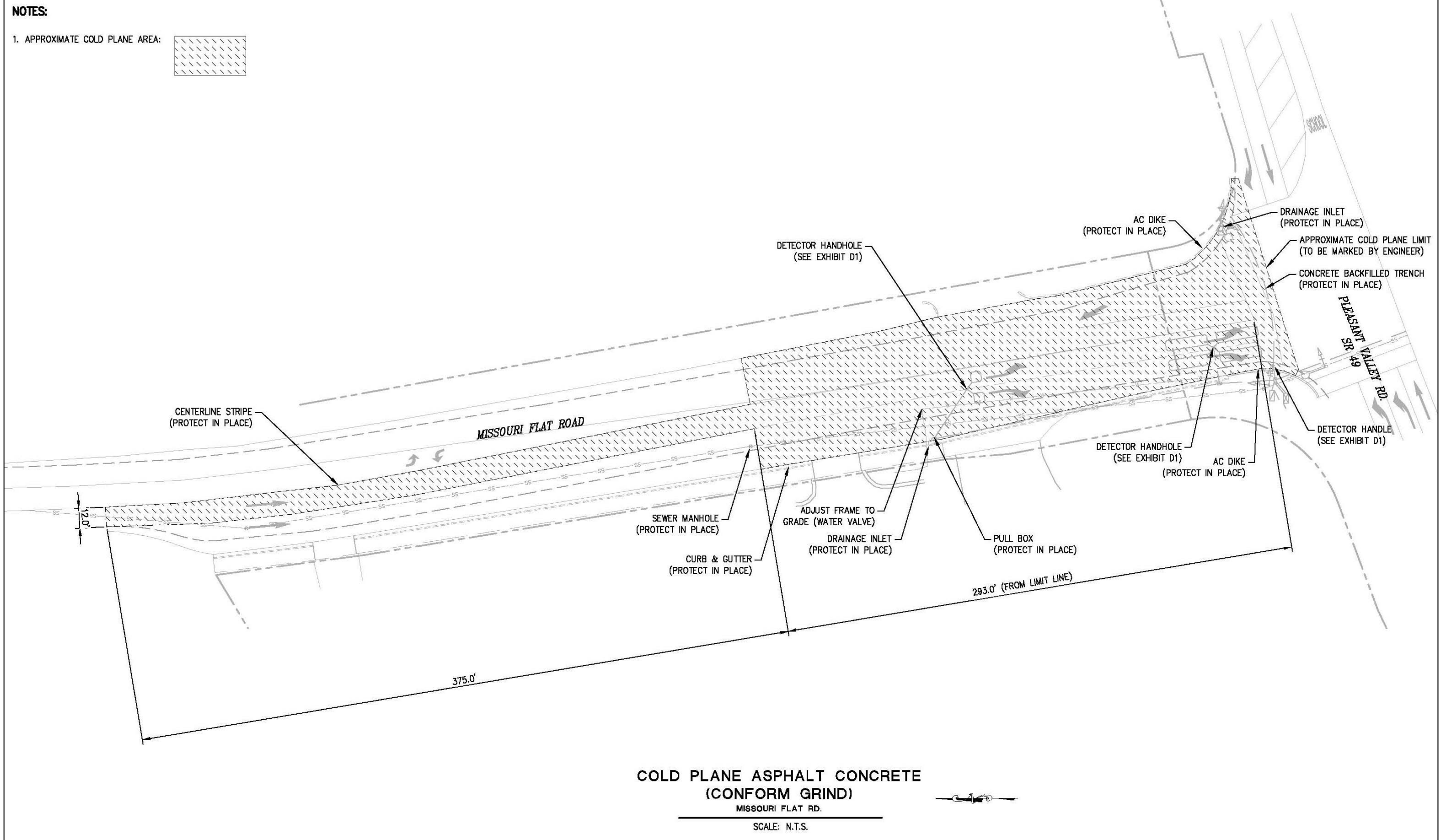

EXHIBIT C

NOTES:

1. SEE STANDARD PLAN SHEETS A20A, A20B, A20D, RSPA24A, A24B, RSPA24E, RSPA24F FOR DETAILS.
2. MATCH EXISTING LANE WIDTHS.
3. ALL QUANTITIES ARE APPROXIMATE.

THERMOPLASTIC STRIPING QUANTITIES		
DETAIL	QUANTITY	UNITS
11	436	LF
22	656	LF
27B	620	LF
38	97	LF
38B	173	LF

THERMOPLASTIC MARKING QUANTITIES		
TYPE	QUANTITY	UNITS
TYPE I ARROW	31	SQ FT
TYPE III (R) ARROW	84	SQ FT
TYPE III (L) ARROW	84	SQ FT
TYPE VI ARROW	42	SQ FT
XW	163	SQ FT
LL	10	SQ FT

PAVEMENT MARKER QUANTITIES		
TYPE	QUANTITY	UNITS
TYPE D	30	EA
TYPE G	24	EA

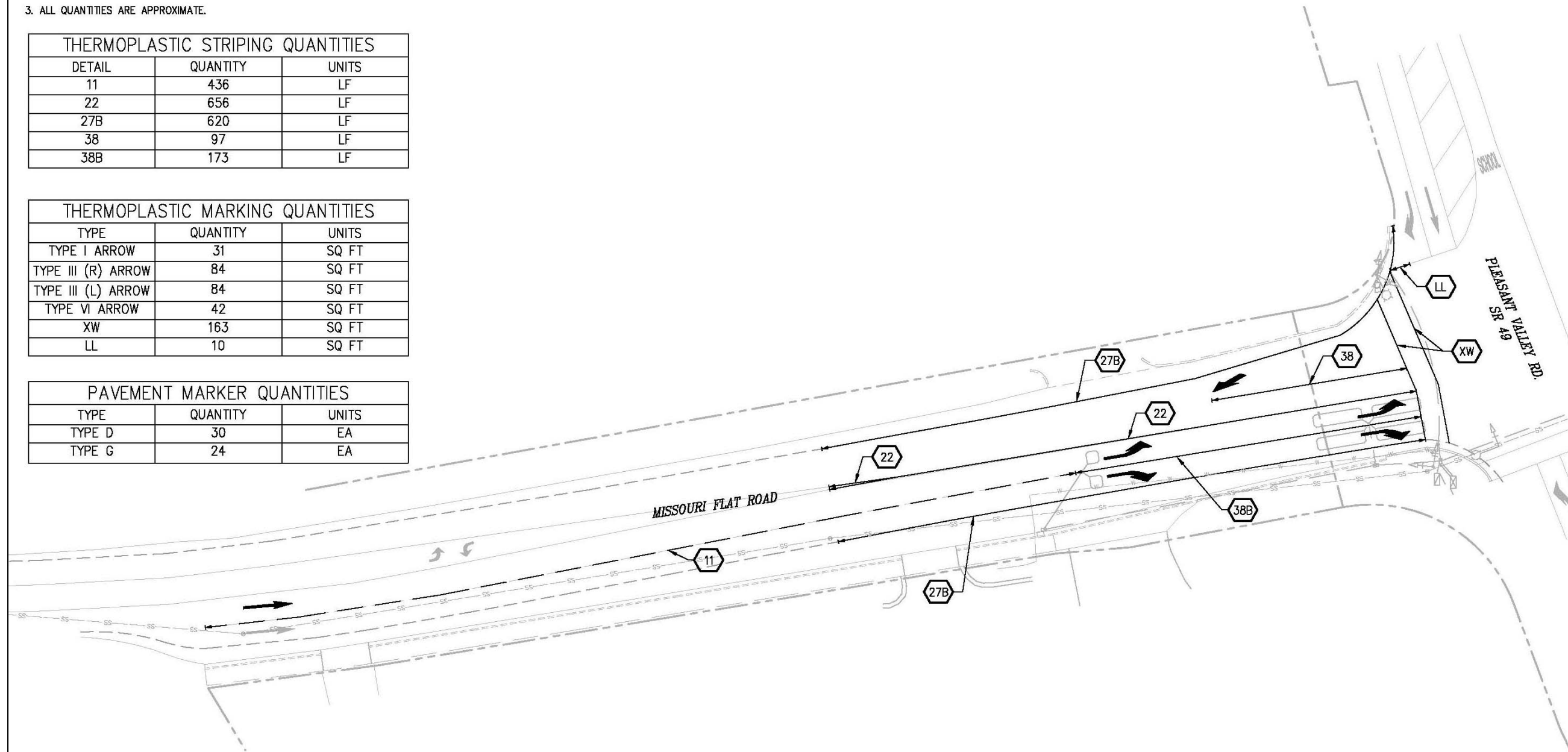

**MISSOURI FLAT RD.
PAVEMENT DELINEATION PLAN**

SCALE: N.T.S.

EXHIBIT D-1

- NOTES:**
- SEE STANDARD PLAN SHEETS RSP ES-1A, RSP ES-1B, RSP ES-1C FOR ABBREVIATION AND SYMBOLS.
 - UTILITY CROSSING POT HOLE PRIOR TO TRENCHING.

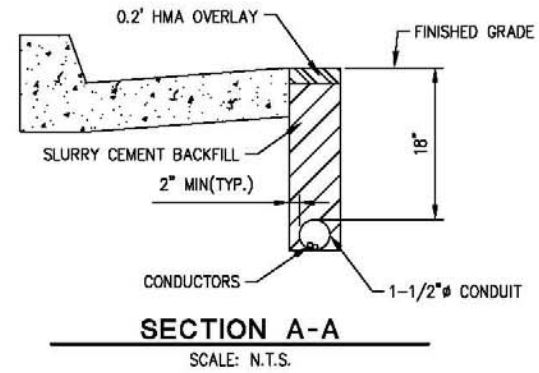

LEGEND:

- dh = Existing detector handhole.
- DH = Install Detector handhole.
- BC = Install pull box in existing conduit run.
- CB = Install conduit into existing pull box.
- RC = Equipment or material to be removed and become the property of the Contractor.
- SC = Splice new to existing conductors.
- (T) = Traffic pull box
- DLC = Loop detector lead-in cable

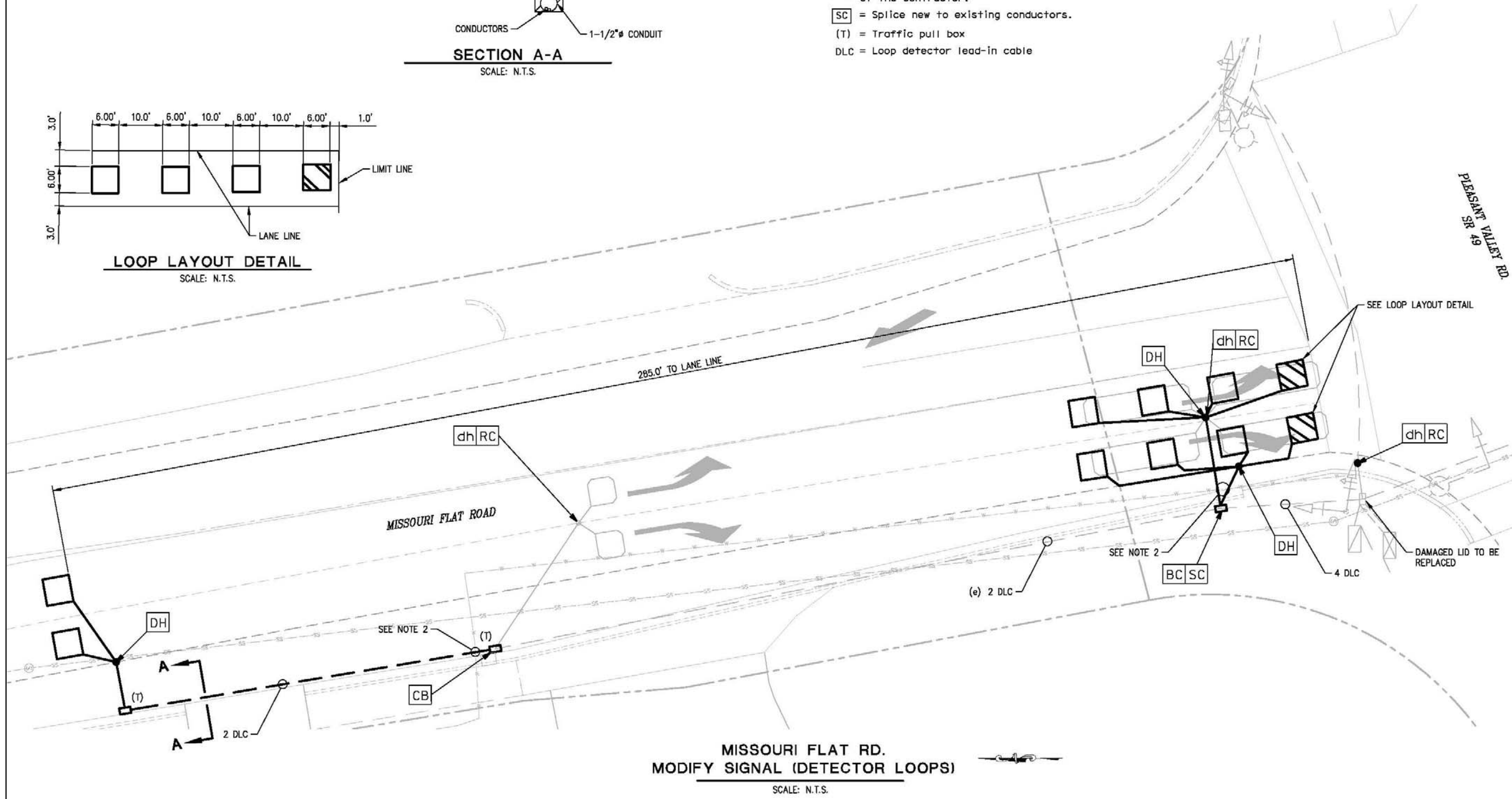
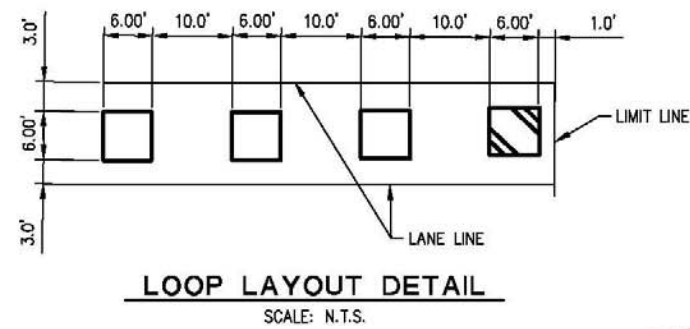

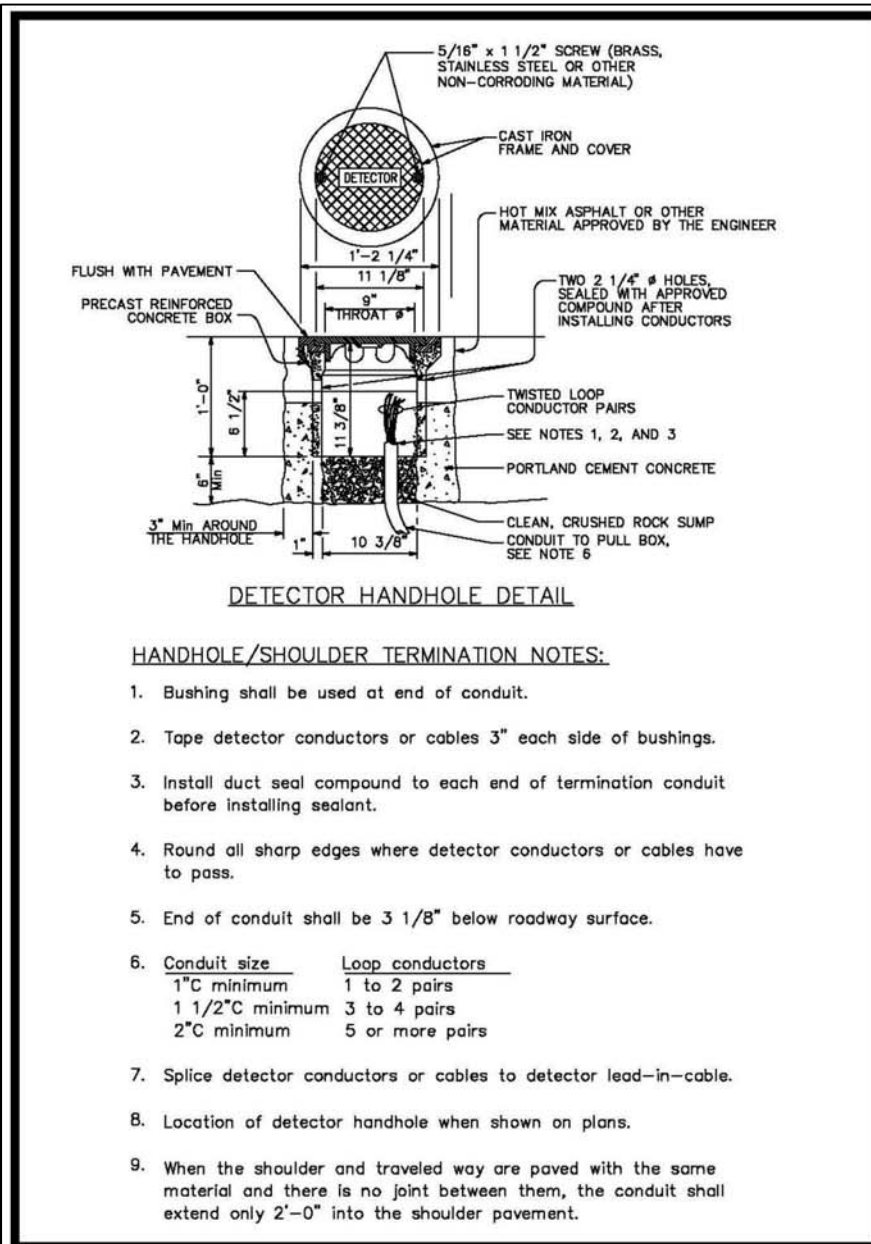

HANDHOLE/SHOULDER TERMINATION NOTES:

1. Bushing shall be used at end of conduit.
2. Tape detector conductors or cables 3" each side of bushings.
3. Install duct seal compound to each end of termination conduit before installing sealant.
4. Round all sharp edges where detector conductors or cables have to pass.
5. End of conduit shall be 3 1/8" below roadway surface.
6.

Conduit size	Loop conductors
1" minimum	1 to 2 pairs
1 1/2" minimum	3 to 4 pairs
2" minimum	5 or more pairs
7. Splice detector conductors or cables to detector lead-in-cable.
8. Location of detector handhole when shown on plans.
9. When the shoulder and traveled way are paved with the same material and there is no joint between them, the conduit shall extend only 2'-0" into the shoulder pavement.

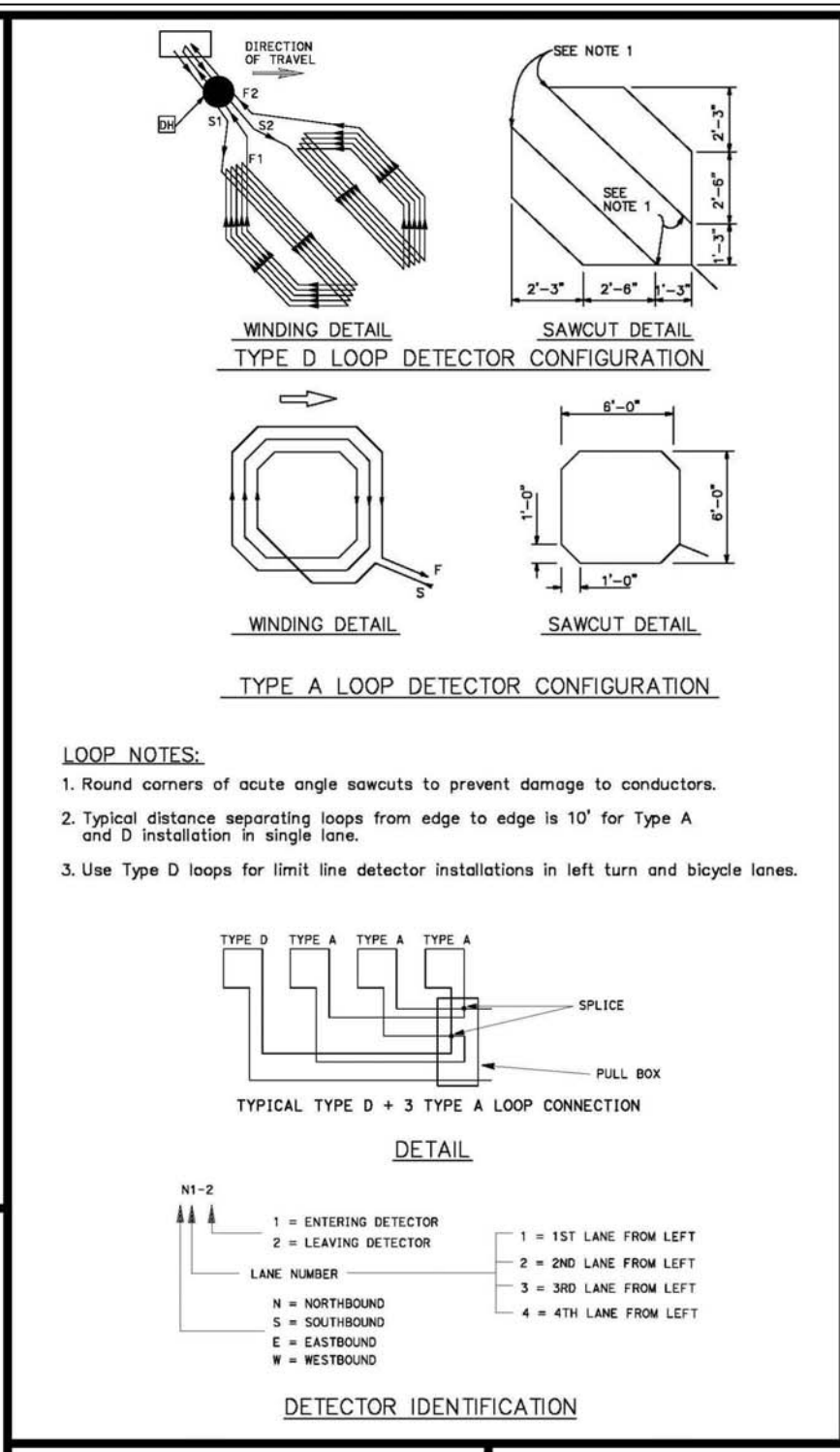
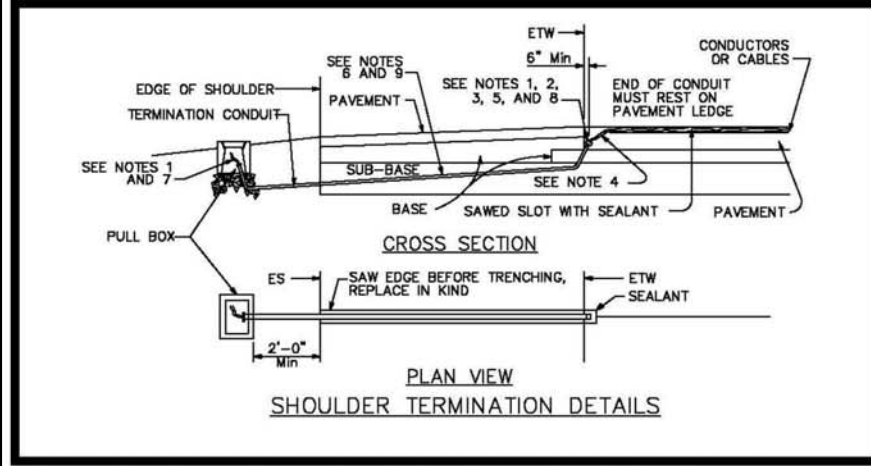

ELECTRICAL DETAILS

SCALE: N.T.S.

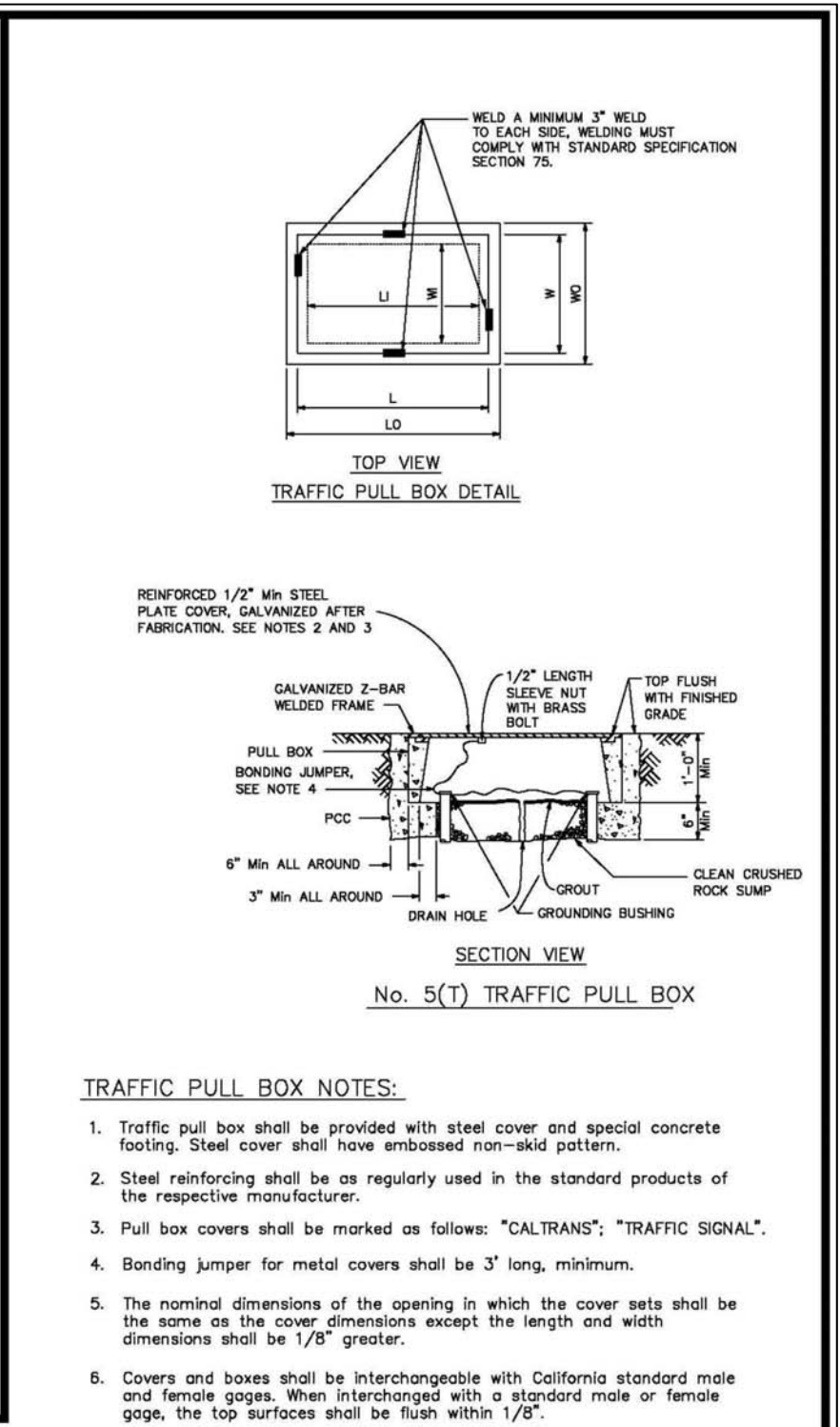

TRAFFIC PULL BOX NOTES:

1. Traffic pull box shall be provided with steel cover and special concrete footing. Steel cover shall have embossed non-skid pattern.
2. Steel reinforcing shall be as regularly used in the standard products of the respective manufacturer.
3. Pull box covers shall be marked as follows: "CALTRANS"; "TRAFFIC SIGNAL".
4. Bonding jumper for metal covers shall be 3' long, minimum.
5. The nominal dimensions of the opening in which the cover sets shall be the same as the cover dimensions except the length and width dimensions shall be 1/8" greater.
6. Covers and boxes shall be interchangeable with California standard male and female gages. When interchanged with a standard male or female gage, the top surfaces shall be flush within 1/8".

DIMENSION TABLE

PULL BOX	PULL BOX				COVER			
	MINIMUM * THICKNESS	MINIMUM DEPTH BOX AND EXTENSION	LO	LI	WO	WI	L **	W **
No. 5(T)	1 3/4"	1'-0"	2'-5" - 2'-6"	2'-0" - 2'-1"	1'-6" - 1'-7"	1'-1" - 1'-2"	2'-3" - 2'-3 1/2"	1'-4" - 1'-4 1/2"

* EXCLUDING CONDUIT WEB ** TOP DIMENSION

EXHIBIT E-1

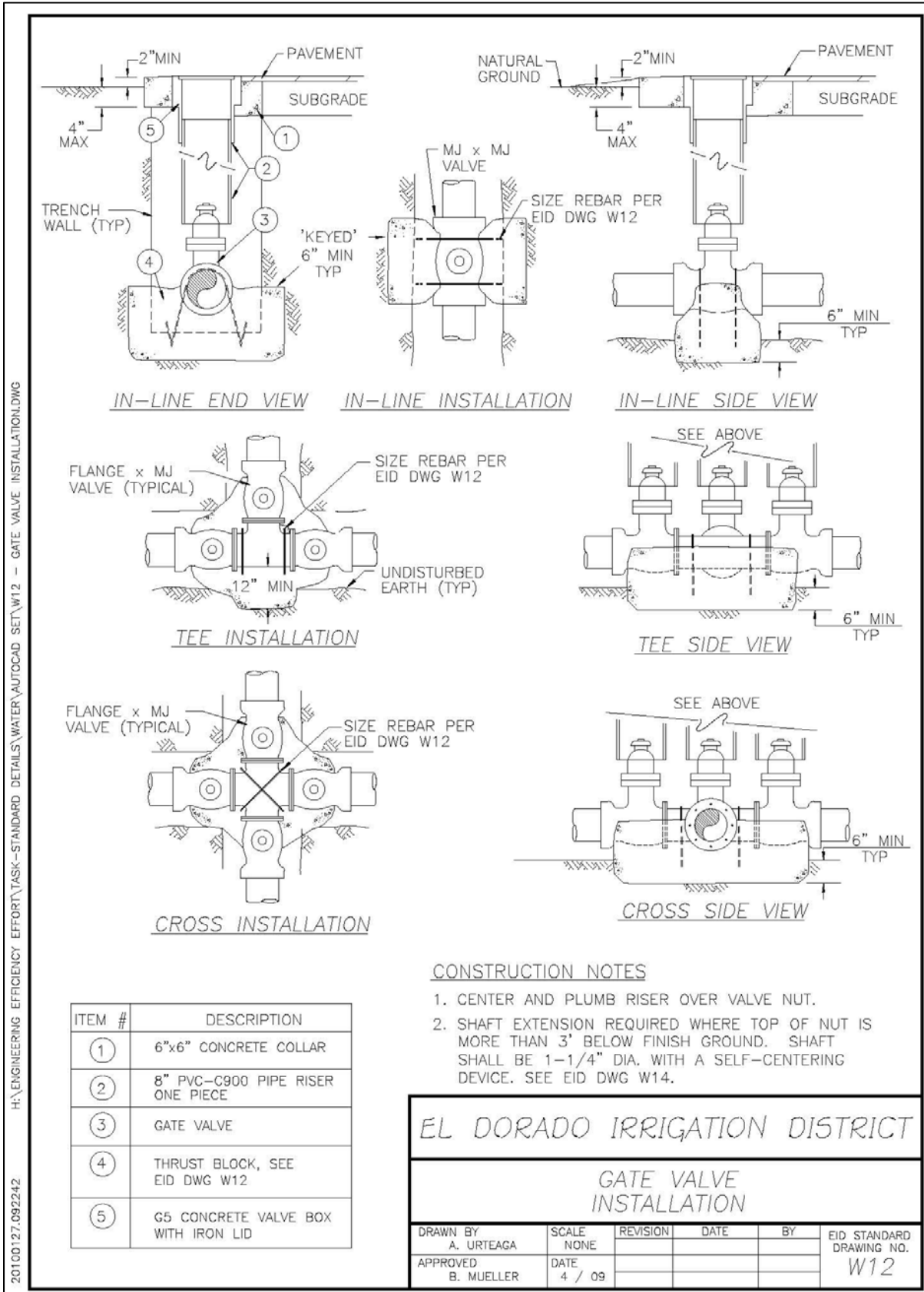

ITEM #	DESCRIPTION
①	6"x6" CONCRETE COLLAR
②	8" PVC-C900 PIPE RISER ONE PIECE
③	GATE VALVE
④	THRUST BLOCK, SEE EID DWG W12
⑤	G5 CONCRETE VALVE BOX WITH IRON LID

CONSTRUCTION NOTES

1. CENTER AND PLUMB RISER OVER VALVE NUT.
2. SHAFT EXTENSION REQUIRED WHERE TOP OF NUT IS MORE THAN 3' BELOW FINISH GROUND. SHAFT SHALL BE 1-1/4" DIA. WITH A SELF-CENTERING DEVICE. SEE EID DWG W14.

EL DORADO IRRIGATION DISTRICT

GATE VALVE INSTALLATION

DRAWN BY A. URTEAGA	SCALE NONE	REVISION	DATE	BY	EID STANDARD DRAWING NO. W12
APPROVED B. MUELLER	DATE 4 / 09				

EXHIBIT E-2

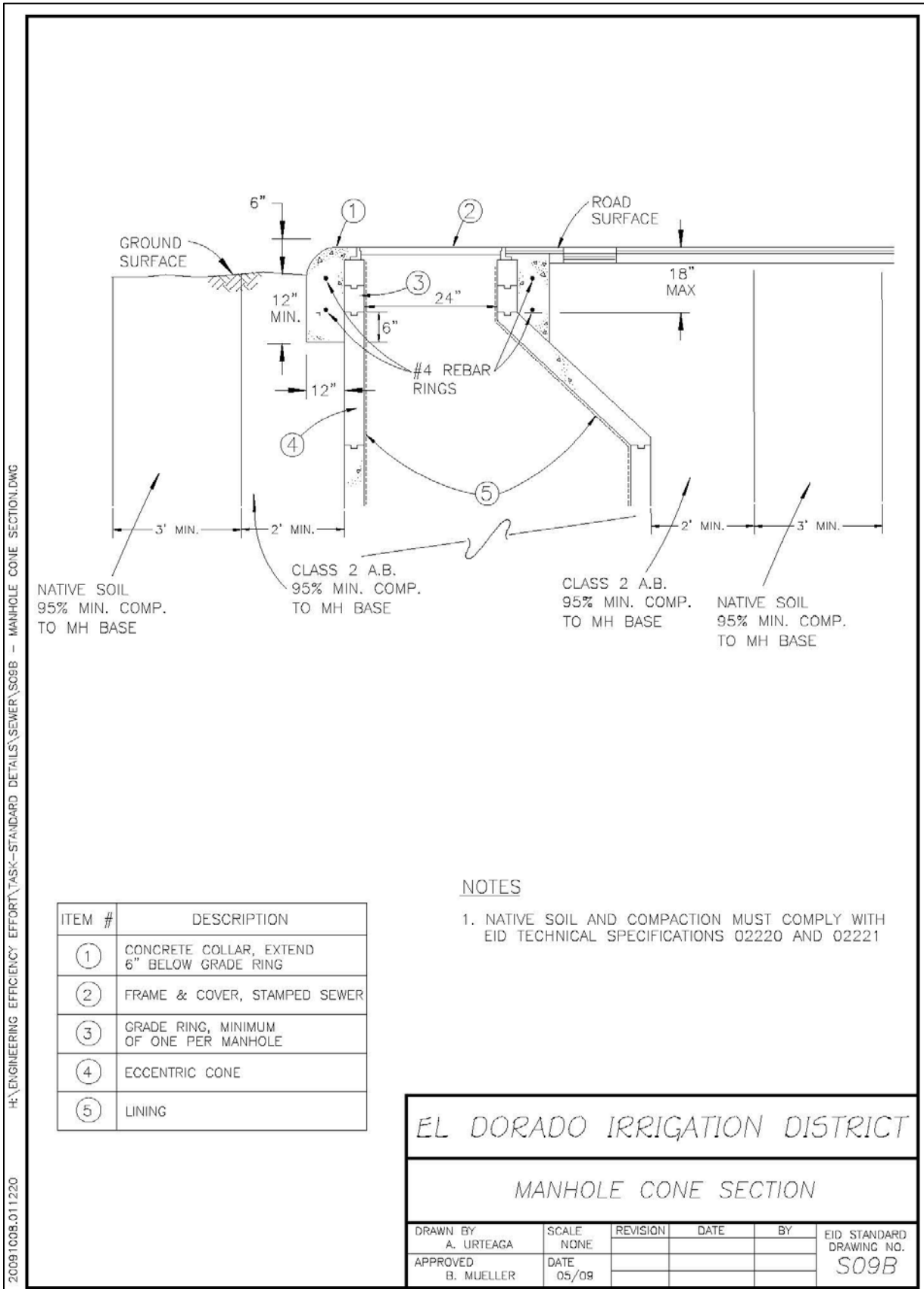

H:\ENGINEERING EFFORTY\TASK-STANDARD DETAILS\SEWER\S09B - MANHOLE CONE SECTION.DWG
20091008.011220

NOTES

1. NATIVE SOIL AND COMPACTION MUST COMPLY WITH EID TECHNICAL SPECIFICATIONS 02220 AND 02221

ITEM #	DESCRIPTION
①	CONCRETE COLLAR, EXTEND 6" BELOW GRADE RING
②	FRAME & COVER, STAMPED SEWER
③	GRADE RING, MINIMUM OF ONE PER MANHOLE
④	ECCENTRIC CONE
⑤	LINING

<i>EL DORADO IRRIGATION DISTRICT</i>					
<i>MANHOLE CONE SECTION</i>					
DRAWN BY A. URTEAGA	SCALE NONE	REVISION	DATE	BY	EID STANDARD DRAWING NO. <i>S09B</i>
APPROVED B. MUELLER	DATE 05/09				

**County of El Dorado, State of California
Community Development Agency
Transportation Division**

PW No. 16-31119 / CIP No. 72190 / P&C No. 356-C1699

PATTERSON DRIVE AND MISSOURI FLAT ROAD OVERLAYS

THIS AGREEMENT ("Agreement") approved by the Board of Supervisors this ____st day of _____, in the year of 20__, made and concluded, in duplicate, between the COUNTY OF EL DORADO, a political subdivision of the State of California, by the Community Development Agency, Transportation Division thereof, the party of the first part hereinafter called "County," and [CONTRACTOR], party of the second part hereinafter called "Contractor."

RECITALS:

WHEREAS, County has caused the above-captioned project to be let to formal bidding process; and

WHEREAS, Contractor has duly submitted a bid response for the captioned project upon which County has awarded this contract;

NOW, THEREFORE, the parties hereto have mutually covenanted and agreed, and by these presents do covenant and agree, each with the other, as follows:

Article 1. THE WORK

The improvement contemplated in the performance of this Contract is an improvement over which the County shall exercise general supervision. The County, therefore, shall have the right to assume full and direct control over this Contract whenever the County, at its sole discretion, shall determine that its responsibility is so required.

Contractor shall complete the Work as specified or indicated under the Bid Schedule(s) of County's Contract Documents entitled:

PATTERSON DRIVE AND MISSOURI FLAT ROAD OVERLAYS

The project is located in County of El Dorado along Patterson Drive between Lake Oaks Drive and Solstice Circle and along Missouri Flat Road between State Highway 49 and approximately seven hundred (700) feet north of State Highway 49, in Diamond Springs. The Work to be done is shown on the Plans, described in the Special Provisions and generally consists of, but is not limited to:

- A. Bids consist of cold planing asphalt concrete, placement of geosynthetic material and hot mix asphalt on cold planed areas, and signal modifications. Other items or details not mentioned above, that are required by the Standard Plans, Standard Specifications, or these Special Provisions must be performed, constructed or installed.

Article 2. CONTRACT DOCUMENTS

The Contract Documents consist of: the Notice to Bidders; the bid forms which include the accepted Proposal, Bid Price Schedule and Total Bid, Subcontractor List, Section 10285.1 Statement, Section 10162 Questionnaire, Section 10232 Statement, Noncollusion Affidavit, Iran Contracting Act Certification, the Contract which includes this Agreement with all Exhibits thereto, including the Performance Bond, and Payment Bond, the drawings listed and identified as the Project Exhibits; the Special Provisions which incorporate by reference the State of California Department of Transportation (Caltrans) Standard Plans 2010, and Standard Specifications 2010, Revised Standard Specifications, and standard drawings from the Design and Improvement Standards Manual of the County of El Dorado, revised March 8, 1994 including Resolution 199-91 and Resolution 58-94 to adopt changes to the Design and Improvement Standards

Manual; all Addenda incorporated in those documents before their execution, and all Contract Change Orders issued in accordance with the Contract Documents which may be delivered or issued after the Effective Date of this Agreement and are not attached hereto; the prevailing Labor Surcharge And Equipment Rental Rates (when required) as determined by the Caltrans to be in effect on the date the Work is accomplished; all the obligations of County and of Contractor which are fully set forth and described therein; and all Contract Documents which are hereby specifically referred to and by such reference made a part hereof. All Contract Documents are intended to cooperate so that any work called for in one and not mentioned in the other is to be executed the same as if mentioned in all Contract Documents. Contractor agrees to perform all of its promises, covenants, and conditions set forth in the Contract Documents, and to abide by and perform all terms and conditions set forth therein. In case of conflict between this Agreement and any other contract document, this Agreement shall take precedence.

Article 3. COVENANTS AND CONTRACT PRICE

County hereby promises and agrees with said Contractor to employ, and does hereby employ, said Contractor to provide the material and to do the Work according to the terms and conditions of the Contract Documents herein contained and referred to, for the prices hereinafter set forth, and hereby contracts to pay the same at the time, in the manner and upon the conditions herein set forth; and the said parties for themselves, their heirs, executors, administrators, successors and assigns, do hereby agree to the full performance of the covenants herein contained. County shall pay Contractor for the completion of the Work in accordance with the Contract Documents in current funds the Contract Prices named in Contractor's Bid and Bid Price Schedule, a copy of which is attached hereto as Exhibit A.

Article 4. COMMENCEMENT AND COMPLETION

The Work to be performed under this Contract shall commence on the date specified in the Notice to Proceed issued by County, and the Work shall be fully completed within the time specified in the Notice to Proceed pursuant to Section 8 of the Special Provisions.

County and Contractor recognize that time is of the essence of the Agreement and that County will suffer financial loss if the Work is not completed within the time specified in the Notice to Bidders annexed hereto, plus any extensions thereof allowed in accordance with Section 8 of the Standard Specifications and Special Provisions. They also recognize the delays, expense, and difficulties involved with proving in a legal proceeding the actual loss suffered by County if the Work is not completed on time. Accordingly, instead of requiring any such proof, County and Contractor agree that as liquidated damages for delay (but not as a penalty) Contractor shall pay County the sum of **one thousand nine hundred dollars (\$1,900)**, as liquidated damages and not as a penalty, for each and every calendar day's delay in finishing the Work in excess of the contract time prescribed herein.

Article 5. INDEMNITY

To the fullest extent allowed by law, Contractor shall defend, indemnify, and hold County, its (their) officers, directors, and employees, and the State of California (State), its officers, directors, agents (excluding agents who are design professionals), State Contractors doing work within the project limits, El Dorado Irrigation District and its (their) officers, directors, and employees associated with this Contract harmless against and from any and all claims, suits, losses, damages, and liability for damages, including attorney's fees and other costs of defense brought for or on account of injuries to or death of any person, including but not limited to, workers and the public, or on account of injuries to or death of County, State employees, or damage to property, or any economic, consequential or special damages which are claimed or which shall in any way arise out of or be connected with Contractor's services, operations or performance hereunder, regardless of the existence or degree of fault or negligence on the part of the County, the State of California, the Contractor, subcontractors or employees of any of these, except for the active, or sole negligence of the County, the State of California, their officers and employees, or where expressly prescribed by statute.

The duty to indemnify and hold harmless the County and State agencies associated with this Contract specifically includes the duties to defend set forth in Section 2778 of the Civil Code. The insurance obligations of Contractor are separate, independent obligations under the Contract Documents, and the provisions of this defense and indemnity are not intended to modify nor should they be construed as modifying or in any way limiting the insurance obligations set forth in the Contract Documents.

This indemnification will remain in effect until terminated or modified in writing by mutual agreement.

Article 6. VENUE

Any litigation arising out of this Contract shall be brought in El Dorado County and governed by California law.

Article 7. NOTIFICATION OF SURETY COMPANY

The surety company shall familiarize itself with all of the conditions and provisions of this Contract, and shall waive the right of special notification of any change or modifications of this Contract or extension of time, or of decreased or increased work, or of the cancellation of the Contract, or of any other act or acts by County or its authorized agents, under the terms of this Contract; and failure to so notify the aforesaid surety company of changes shall in no way relieve the surety company of its obligation under this Contract.

Article 8. ASSIGNMENT OF ANTITRUST ACTIONS

In entering into a public works contract or a subcontract to supply goods, services, or materials pursuant to a public works contract, the Contractor offers and agrees and will require all of its subcontractors and suppliers to agree to assign to the awarding body all rights, title, and interest in and to all causes of action it may have under Section 4 of the Clayton Act (15 U.S.C. Sec. 15) or under the Cartwright Act (Chapter 2 (commencing with Section 16700) of Part 2 of Division 7 of the Business and Professions Code), arising from purchases of goods, services, or materials pursuant to the public works contract or the subcontract. This assignment shall be made and become effective at the time the awarding body tenders final payment to Contractor, without further acknowledgment by the parties.

If an awarding body or public purchasing body receives, either through judgment or settlement, a monetary recovery for a cause of action assigned under Government Code Sections 4550-4554, the assignor shall be entitled to receive reimbursement for actual legal costs incurred and may, upon demand, recover from the public body any portion of the recovery, including treble damages, attributable to overcharges that were paid by the assignor but were not paid by the public body as part of the bid price, less the expenses incurred in obtaining that portion of the recovery. Upon demand in writing by the assignor, the assignee shall, within one year from such demand, reassign the cause of action assigned under Government Code Sections 4550-4554 if the assignor has been or may have been injured by the violation of law for which the cause of action arose and (a) the assignee has not been injured thereby, or (b) the assignee declines to file a court action for the cause of action.

Article 9. TERMINATION BY COUNTY FOR CONVENIENCE

County reserves the right to terminate the Contract at any time upon determination by County's representative that termination of the Contract is in the best interest of County. County shall issue Contractor a written notice specifying that the Contract is to be terminated.

Upon receipt of said written notice, Contractor shall stop all work under the Contract except: (1) work specifically directed to be completed prior to termination, (2) work the Inspector deems necessary to secure the project for termination, (3) removal of equipment and plant from the site of the Work, (4) action that is necessary to protect materials from damage, (5) disposal of materials not yet used in the Work as directed by County, and (6) cleanup of the site.

If the Contract is terminated for County's convenience as provided herein, all finished or unfinished work and materials previously paid for shall, at the option of County, become its property. Contractor shall be paid an amount which reflects costs incurred for work provided to the date of notification of termination. In

addition, Contractor shall be paid the reasonable cost, as solely judged by County, and without profit, for all work performed to secure the project for termination.

Article 10. TERMINATION BY COUNTY FOR CAUSE

If Contractor is adjudged as bankrupt or insolvent, or makes a general assignment for the benefit of its creditors or if a trustee or receiver is appointed for Contractor or for any of its property, or if Contractor files a petition to take advantage of any debtor's act, or to reorganize under the bankruptcy or applicable laws, or on more than one occasion fails to supply sufficient skilled workmen or suitable material or equipment, or on more than one occasion fails to make prompt payments to subcontractors for labor, materials, or equipment, or disregards the authority of the County's representative, or the Engineer, if one is appointed, or otherwise violates any provision of the Contract Documents, then County may, without prejudice to any other right or remedy and after giving Contractor and its Surety a minimum of ten (10) days from delivery of a written termination notice, terminate the services of Contractor and take equipment and machinery thereon owned by Contractor and finish the Work by whatever method County may deem expedient. In such case, Contractor shall not be entitled to receive any further payment until the Work is finished.

Without prejudice to other rights or remedies County may have, if Contractor fails to begin delivery of materials and equipment, to commence Work within the time specified, to maintain the rate of delivery of material, to execute the Work in the manner and at such locations as specified, or fails to maintain a work program which will ensure County's interest, or, if Contractor is not carrying out the intent of the Contract, an Inspector's written notice may be served upon Contractor and the Surety on its faithful performance bond demanding satisfactory compliance with the Contract. If Contractor or its Surety does not comply with such notice within five (5) days after receiving it, or after starting to comply, fails to continue, County may exclude it from the premises and take possession of all material and equipment, and complete the Work by County's own forces, by letting the unfinished Work to another Contractor, or by a combination of such methods.

Where Contractor's services have been so terminated by County, said termination shall not affect any right of County against Contractor then existing or which may thereafter accrue. Any retention or payment of monies by County due Contractor will not release Contractor from compliance with the Contract Documents.

If the unpaid balance of the Contract price exceeds the direct and indirect costs of completing the Work, including compensation for additional professional services, such excess shall be paid to Contractor. If the sums under the Contract are insufficient for completion, Contractor or Surety shall pay to County within five (5) days after the completion, all costs in excess of the Contract price. In any event, the cost of completing the Work shall be charged against Contractor and its Surety and may be deducted from any money due or becoming due from County.

The provisions of this Article shall be in addition to all other rights and remedies available to County under law.

If after notice of termination, it is determined for any reason that Contractor was not in default, the rights and obligations of the parties shall be the same as if the notice of termination had not been issued. The Contract shall be equitably adjusted to compensate for such termination.

Article 11. SUCCESSORS AND ASSIGNS

This Agreement shall bind and inure to the heirs, devisees, assignees, and successors in interest of Contractor and to the successors in interest of County in the same manner as if such parties had been expressly named herein.

Article 12. REPORTING ACCIDENTS

Contractor shall prepare and submit (within 24 hours of such incidents) reports of accidents at the site and anywhere else the work is in progress in which bodily injury is sustained or property loss in excess of Five Hundred Dollars (\$500.00) occurs.

Article 13. EMISSIONS REDUCTION

Contractor shall comply with emission reduction regulations mandated by the California Air Resources Board, and sign a certification of knowledge thereof:

CERTIFICATE OF KNOWLEDGE – EMISSIONS REDUCTION REGULATIONS

I am aware of the emissions reduction regulations being mandated by the California Air Resources Board. I will comply with such regulations before commencing the performance of the Work and maintain compliance throughout the duration of this Contract.

Signed: _____ Date _____

Article 14. WORKERS' COMPENSATION CERTIFICATION

Contractor shall comply with Labor Code Sections 3700 et seq., requiring it to obtain Workers' Compensation Insurance, and sign a certificate of knowledge thereof.

CERTIFICATE OF KNOWLEDGE - LABOR CODE SECTION 3700

I am aware of the provisions of Section 3700 of the Labor Code, which require every employer to be insured against liability for workers' compensation or to undertake self-insurance in accordance with the provisions of that Code, and I will comply with such provisions before commencing the performance of work of this Contract.

Signed: _____ Date _____

Article 15. WARRANTY

Contractor warrants to County that materials and equipment furnished for the Work will be of good quality and new, unless otherwise required or permitted under the Contract Documents, that the Work will be free from defects or flaws and is of the highest quality of workmanship and that the Work will conform with the requirements herein. Work not conforming to these requirements, including substitutions not properly approved and authorized, shall be considered defective.

Article 16. RETAINAGE

The retainage from payment is set forth in Section 9-1.16F(1) of the Special Provisions. Contractor may elect to receive one hundred percent (100%) of payments due as set forth in the Contract Documents, without retention, by depositing securities of equivalent value with County, in accordance with, and as set forth in Section 22300 of the Public Contract Code. Securities eligible for deposit hereunder shall be limited to those listed in Section 16430 of the Government Code, or bank or savings and loan certificates of deposit.

**Article 17. DISADVANTAGED BUSINESS ENTERPRISE (DBE) PROGRAM
RESERVED**

Article 18. PREVAILING WAGE REQUIREMENTS

In accordance with the provisions of California Labor Code Sections 1770 et seq., including but not limited to Sections 1773, 1773.1, 1773.2, 1773.6, and 1773.7, the general prevailing rate of wages in the county in which the Work is to be done has been determined by the Director of the California Department of Industrial Relations. Interested parties can obtain the current wage information by submitting their requests to the Department of Industrial Relations, Division of Labor Statistics and Research, PO Box 420603, San Francisco CA 94142-0603, Telephone (415) 703-4708 or by referring to the website at <http://www.dir.ca.gov/OPRL/PWD>. The rates at the time of the bid advertisement date of a project will remain in effect for the life of the project in accordance with the California Code of Regulations, as modified and effective January 27, 1997.

Copies of the general prevailing rate of wages in the county in which the Work is to be done are also on file at the Community Development Agency, Transportation Division's principal office, and are available upon request.

In accordance with the provisions of Labor Code 1810, eight (8) hours of labor constitutes a legal day's work upon all work done hereunder, and Contractor and any subcontractor employed under this Contract must conform to and be bound by the provisions of Labor Code Sections 1810 through 1815.

Article 19. NONDISCRIMINATION

- A. In connection with its performance under this Contract, Contractor shall comply with all applicable nondiscrimination statutes and regulations during the performance of this Contract including, but not limited to the following: Contractor, its employees, subcontractors and representatives shall not unlawfully discriminate against any employee or applicant for employment because of race, color, sex, sexual orientation, religion, ancestry or national origin, physical disability, medical condition, marital status, political affiliation, family and medical care leave, pregnancy leave or disability leave. Contractor will take affirmative action to ensure that employees are treated during employment, without regard to their race, color, sex, sexual orientation, religion, ancestry or national origin, physical disability, medical condition, marital status, political affiliation, family and medical care leave, pregnancy leave or disability leave. Such action shall include, but not be limited to, the following: employment, upgrading, demotion or transfer; recruitment or recruitment advertising; layoff or termination; rates of pay or other forms of compensation; and selection for training, including apprenticeship. Contractor shall post in conspicuous places, available to employees for employment, notices to be provided by State setting forth the provisions of this Fair Employment section. Contractor shall, unless exempt, comply with the applicable provisions of the Fair Employment and Housing Act (Government Code, Sections 12900 et seq.) and applicable regulations promulgated thereunder (California Code of Regulations, Title 2, Sections 7285.0 et seq.); the applicable regulations of the Fair Employment and Housing Commission implementing Government Code, Section 12990, set forth in Chapter 5 of Division 4 of Title 2 of the California Code of Regulations incorporated into this Agreement by reference and made a part hereof as if set forth in full; and Title VI of the Civil Rights Act of 1964, as amended. Contractor, its employees, subcontractors and representatives shall give written notice of their obligations under this clause as required by law.
- B. Where applicable, Contractor shall include these nondiscrimination and compliance provisions in any of its subcontracts that affect or are related to the Work performed herein.
- C. Reserved
- D. Contractor's signature executing this Contract shall provide any certifications necessary under the federal laws and the laws of the State of California, including but not limited to Government Code Section 12990 and Title 2, California Code of Regulations, Section 8103.

Article 20. CONTRACTOR ASSURANCES

Patterson Drive and Missouri Flat Road Overlays
Contract No. PW 16-31119 / CIP No. 72190 / P&C No. 356-C1699
May 17, 2016

County of El Dorado
Agreement
Page D-6

By executing this Contract, Contractor certifies that it:

- a. Will abide by all administrative, contractual or legal remedies in instances where Contractor violates or breaches contract terms, and will comply with sanctions and penalties as the Contract Administrator deems appropriate.
- b. Will comply with the termination for cause and termination for convenience provisions of the Contract including the manner by which such termination may be effected and the basis for settlement afforded by those provisions.
- c. Will comply with County, State of California and FHWA requirements and regulations pertaining to:
(a) reporting; (b) patent rights with respect to any discovery or invention which arises or is developed in the course of or under this Contract; and (c) copyrights and rights in data.

Any subcontract entered into as a result of this Contract shall contain all of the provisions of this Article.

Article 21. BUSINESS LICENSE

The County Business License Ordinance provides that it is unlawful for any person to furnish supplies or services, or transact any kind of business in the unincorporated territory of County of El Dorado without possessing a County business license unless exempt under County Ordinance Code Section 5.08.070. Contractor warrants and represents that it shall comply with all of the requirements of the County Business License Ordinance, where applicable, prior to beginning work under this Contract and at all times during the term of this Contract.

Article 22. TAXES

Contractor certifies that as of today's date, it is not in default on any unsecured property taxes or other taxes or fees owed by Contractor to County. Contractor agrees that it shall not default on any obligations to County during the term of this Agreement.

Article 23. CONTRACT ADMINISTRATOR

The County Officer or employee with responsibility for administering this Agreement is John Kahling, Deputy Director Engineering, Headington Unit, Community Development Agency, Transportation Division, or successor.

Article 24. AUTHORIZED SIGNATURES

The parties hereto represent that the undersigned individuals executing this Agreement on behalf of their respective parties are fully authorized to do so by law or other appropriate instrument and to bind upon said parties the obligations set forth herein.

Article 25. PARTIAL INVALIDITY

If any provision of this Agreement is held by a court of competent jurisdiction to be invalid, void or unenforceable, the remaining provisions will continue in full force and effect without being impaired or invalidated in any way.

Article 26. NO THIRD PARTY BENEFICIARIES

Nothing in this Agreement is intended, nor will be deemed, to confer rights or remedies upon any person or legal entity not a party to this Agreement.

Article 27. COUNTERPARTS

This Agreement may be executed in one or more counterparts, each of which shall be an original and all of which together shall constitute one and the same instrument.

Article 28. ENTIRE AGREEMENT

This document and the documents referred to herein or exhibits hereto are the entire Agreement between the parties and they incorporate or supersede all prior written or oral agreements or understandings.

Draft

IN WITNESS WHEREOF, the said Community Development Agency, Transportation Division of the County of El Dorado, State of California, has caused this Agreement to be executed by County's Board of Supervisors, on its behalf, and the said Contractor has signed this Agreement the day and year written below.

COUNTY OF EL DORADO

Dated: _____

Board Date: _____

Chair, Board of Supervisors

Attest:
James S. Mitrison
Clerk of the Board of Supervisors

Dated: _____

Board Date: _____

Deputy Clerk

CONTRACTOR

Dated: _____

License No.

Federal Employee Identification
Number

By: _____
President

By: _____
Corporate Secretary

NOTE: If Contractor is a corporation, the legal name of the corporation shall be set forth above together with the signature of the officer or officers authorized to sign contracts on behalf of the corporation; if Contractor is a co-partnership, the true name of the firm shall be set forth above together with the signature of the partner or partners authorized to sign contracts on behalf of the co-partnership; and if Contractor is an individual, his/her signature shall be placed above. Contractor executing this document on behalf of a corporation or partnership shall be prepared to demonstrate by resolution, article, or otherwise that it is appropriately authorized to act in these regards. For such corporation or partnership, such authority shall be demonstrated to the satisfaction of County. If signature is by an agent, other than officer of a corporation or a member of a partnership, an appropriate Power of Attorney shall be on file with the County prior to signing this document.

Mailing Address: _____

Business Address: _____

Email Address: _____

Phone: _____ Fax: _____

EXHIBIT A

**CONTRACTOR'S BID AND BID PRICE SCHEDULE
PATTERSON DRIVE AND MISSOURI FLAT ROAD OVERLAYS PROJECT
CONTRACT NO. PW 16-31119 / CIP NO. 72190**

ITEM NO.	ITEM CODE	ITEM DESCRIPTION	UNIT OF MEASURE	ESTIMATE D QUANTITY	UNIT PRICE (IN FIGURES)	ITEM TOTAL (IN FIGURES)
1	070030	LEAD COMPLIANCE PLAN	LS	1		
2	120100	TRAFFIC CONTROL SYSTEM	LS	1		
3	128651A	PORTABLE CHANGEABLE MESSAGE SIGN	SWD	70		
4	130100	JOB SITE MANAGEMENT	LS	1		
5	141103	REMOVE YELLOW THERMOPLASTIC TRAFFIC STRIPE (HAZERDOUS WASTE)	LF	656		
6	149001A	PREPARE FUGITIVE DUST CONTROL PLAN	LS	1		
7	152438A	ADJUST FRAME AND COVER TO GRADE (WATER VALVE) (EID REIMBURSEMENT)	EA	10		
8	152438B	ADJUST FRAME AND COVER TO GRADE (MANHOLE) (EID REIMBURSEMENT)	EA	26		
9	153103A	COLD PLANE ASPHALT CONCRETE PAVEMENT (CONFORM GRIND)	SQYD	15500		
10	153103B	COLD PLANE ASPHALT CONCRETE PAVEMENT (PROFILE GRIND)	SQYD	11875		
11	390132	HOT MIX ASPHALT (TYPE A)	TON	3750		
12	393006	P GEOSYNTHETIC PAVEMENT INTERLAYER (PAVING GRID)	SQYD	27375		
13	840504	4" THERMOPLASTIC TRAFFIC STRIPE	LF	26200		

Patterson Drive and Missouri Flat Road Overlays
Contract No. PW 16-31119 / CIP No. 72190 / P&C No. 356-C1699
 May 17, 2016

County of El Dorado
Agreement
 Page D-10

ITEM NO.	ITEM CODE	ITEM DESCRIPTION	UNIT OF MEASURE	ESTIMATE D QUANTITY	UNIT PRICE (IN FIGURES)	ITEM TOTAL (IN FIGURES)
14	840506	8" THERMOPLASTIC TRAFFIC STRIPE	LF	270		
15	840515	THERMOPLASTIC PAVEMENT MARKING	SQFT	1100		
16	850111	P PAVEMENT MARKER (RETROREFLECTIVE)	EA	560		
17	860090	MAINTAINING EXISTING TRAFFIC MANANGEMENT SYSTEM ELEMENTS DURING CONSTRUCTION	LS	1		
18	861501	MODIFY SIGNAL AND LIGHTING	LS	1		
19	999990	MOBILIZATION	LS	1		
TOTAL BID						

(F) Final Pay Quantity

(P) Eligible for Partial Payment

(LS) Lump Sum

COUNTY OF EL DORADO

PAYMENT BOND

(Section 3247, Civil Code)

Bond No. _____

WHEREAS, the County of El Dorado, a political subdivision of the State of California, hereafter referred to as "Obligee", has awarded to Contractor

_____ hereafter referred to as "Principal", a contract for the work described as follows:

**PATTERSON DRIVE AND MISSOURI FLAT ROAD OVERLAYS
CONTRACT No. PW 16-31119 / CIP No. 72190, P&C No. 356-C1699**

WHEREAS, said Principal is required to furnish a bond in connection with said contract, guaranteeing the faithful performance thereof:

NOW, THEREFORE, we the undersigned Principal and Surety are held and firmly bound unto the Obligee, in the

sum of _____ Dollars,

(\$ _____) to be paid to the Obligee, for which payment we bind ourselves, jointly and severally.

THE CONDITION OF THIS OBLIGATION IS SUCH,

That if said Principal or its subcontractors shall fail to pay any of the persons named in Civil Code Section 3181, or amounts due under the Unemployment Insurance Code with respect to work or labor performed by such claimant, or any amounts required to be deducted, withheld, and paid over to the Franchise Tax Board from the wages of employees of the Principal and his subcontractors pursuant to Section 18806 of the Revenue and Taxation Code, with respect to such work and labor, that the Surety herein will pay for the same in an amount not exceeding the sum specified in this bond, otherwise the above obligation shall be void. In case suit is brought upon this bond, the Surety will pay a reasonable attorney's fee to be fixed by the court.

This bond shall inure to the benefit of any of the persons named in Civil Code Section 3181 as to give a right of action to such persons or their assigns in any suit brought upon this bond.

Dated: _____

Correspondence or Claims relating to this bond should be sent to the Surety at the following address:

PRINCIPAL

SURETY

ATTORNEY-IN-FACT

NOTE: Signatures of those executing for the Principal and for the Surety must be properly acknowledged, and a Power of Attorney attached for the Surety.

NOTARY ACKNOWLEDGMENTS ATTACHED

PRINCIPAL

ACKNOWLEDGMENT

A notary public or other officer completing this certificate verifies only the identity of the individual who signed the document to which this certificate is attached, and not the truthfulness, accuracy, or validity of that document.

State of California

County of _____

On _____ before me, _____,
(here insert name and title of the officer)

personally appeared _____

_____ ,

who proved to me on the basis of satisfactory evidence to be the person(s) whose name(s) is/are subscribed to the within instrument and acknowledged to me that he/she/they executed the same in his/her/their authorized capacity(ies), and that by his/her/their signature(s) on the instrument the person(s), or the entity upon behalf of which the person(s) acted, executed the instrument.

I certify under PENALTY OF PERJURY under the laws of the State of California that the foregoing paragraph is true and correct.

WITNESS my hand and official seal.

Signature _____

(Seal)

SURETY

ACKNOWLEDGMENT

A notary public or other officer completing this certificate verifies only the identity of the individual who signed the document to which this certificate is attached, and not the truthfulness, accuracy, or validity of that document.

State of California

County of _____

On _____ before me, _____,
(here insert name and title of the officer)

personally appeared _____

_____ ,

who proved to me on the basis of satisfactory evidence to be the person(s) whose name(s) is/are subscribed to the within instrument and acknowledged to me that he/she/they executed the same in his/her/their authorized capacity(ies), and that by his/her/their signature(s) on the instrument the person(s), or the entity upon behalf of which the person(s) acted, executed the instrument.

I certify under PENALTY OF PERJURY under the laws of the State of California that the foregoing paragraph is true and correct.

WITNESS my hand and official seal.

Signature _____

(Seal)

COUNTY OF EL DORADO

PERFORMANCE BOND

Bond No. _____

KNOW ALL MEN BY THESE PRESENTS, that we _____

the Contractor in the Contract hereto annexed, as Principal, and _____

as Surety, are held firmly bound unto the County of El Dorado, a political subdivision of the State of California, hereinafter called the "Obligee"

in the sum of _____ DOLLARS,

(\$ _____) lawful money of the United States, for which payment, well and truly to

be made, we bind ourselves, jointly and severally, firmly by these presents.

Signed, sealed and dated: _____

The condition of the above obligation is such that if said Principal as Contractor in the Contract hereto annexed shall faithfully perform each and all of the conditions of said Contract to be performed by him, and shall furnish all tools, equipment, apparatus, facilities, transportation, labor and material, other than material, if any, agreed to be furnished by the Obligee, necessary to perform and complete, and to perform and complete in a good and workmanlike manner, the work of **Contract No. PW 16-31119 / CIP No. 72190 / P&C No. 356-C1699 for the Patterson Drive and Missouri Flat Road Overlays** in strict conformity with the terms and conditions set forth in the Contract hereto annexed, then this obligation shall be null and void; otherwise this bond shall remain in full force and effect and the said Surety will complete the Contract work under its own supervision, by Contract or otherwise, and pay all costs thereof for the balance due under terms of the Contract, and the said Surety, for value received, hereby stipulates and agrees that no change, extension of time, alteration or addition to the terms of the Contract or to the work to be performed thereunder shall in any wise affect its obligation on this bond, and it does hereby waive notice of any such change, extension of time, alteration or addition to the terms of the Contract or to the work.

In the event suit is brought upon this bond by the Obligee and judgment is recovered, the Surety shall pay all costs incurred by the Obligee in such suit, including a reasonable attorney's fee to be fixed by the court.

This guarantee shall insure the Obligee during the work required by any Contract and for a period of one (1) year from the date of acceptance of the work against faulty or improper materials or workmanship that may be discovered during that time.

No right of action shall accrue under this bond to or for the use of any person other than the Obligee named herein.

Dated: _____, 20_____.

Correspondence or Claims relating to this bond should be sent to the Surety at the following address:

PRINCIPAL

SURETY

ATTORNEY-IN-FACT

NOTE: Signatures of those executing for the Principal and the Surety must be properly acknowledged, and a Power of Attorney attached for the Surety.

NOTARY ACKNOWLEDGMENTS ATTACHED

PRINCIPAL

ACKNOWLEDGMENT

A notary public or other officer completing this certificate verifies only the identity of the individual who signed the document to which this certificate is attached, and not the truthfulness, accuracy, or validity of that document.

State of California

County of _____

On _____ before me, _____,
(here insert name and title of the officer)

personally appeared _____

_____ ,

who proved to me on the basis of satisfactory evidence to be the person(s) whose name(s) is/are subscribed to the within instrument and acknowledged to me that he/she/they executed the same in his/her/their authorized capacity(ies), and that by his/her/their signature(s) on the instrument the person(s), or the entity upon behalf of which the person(s) acted, executed the instrument.

I certify under PENALTY OF PERJURY under the laws of the State of California that the foregoing paragraph is true and correct.

WITNESS my hand and official seal.

Signature _____

(Seal)

SURETY

ACKNOWLEDGMENT

A notary public or other officer completing this certificate verifies only the identity of the individual who signed the document to which this certificate is attached, and not the truthfulness, accuracy, or validity of that document.

State of California

County of _____

On _____ before me, _____,
(here insert name and title of the officer)

personally appeared _____

_____ ,

who proved to me on the basis of satisfactory evidence to be the person(s) whose name(s) is/are subscribed to the within instrument and acknowledged to me that he/she/they executed the same in his/her/their authorized capacity(ies), and that by his/her/their signature(s) on the instrument the person(s), or the entity upon behalf of which the person(s) acted, executed the instrument.

I certify under PENALTY OF PERJURY under the laws of the State of California that the foregoing paragraph is true and correct.

WITNESS my hand and official seal.

Signature _____

(Seal)

COMPLETING BID IN PENCIL, ERASURES, OVERWRITES, AND USE OF CORRECTION FLUID OR TAPE ARE NOT ACCEPTABLE. BID PROPOSALS WITH PENCIL, ERASURES, OVERWRITES, OR USE OF CORRECTION FLUID OR TAPE WILL BE REJECTED. ALL CHANGES MUST BE LINED OUT AND CORRECTIONS INSERTED ADJACENT TO AND INITIALED BY THE BIDDER'S AUTHORIZED REPRESENTATIVE.

PROPOSAL

(to be submitted with Bidder's Security)

TO: COUNTY OF EL DORADO,
STATE OF CALIFORNIA
COMMUNITY DEVELOPMENT AGENCY
TRANSPORTATION DIVISION,

for the construction of
the

**PATTERSON DRIVE AND MISSOURI FLAT ROAD OVERLAYS
CONTRACT No. PW 16-31119 / CIP No. 72190**

NAME OF BIDDER _____

MAILING ADDRESS _____

CITY, STATE, ZIP _____

PHYSICAL ADDRESS _____

(Please include even if Mailing Address used)

CITY, STATE, ZIP _____

TELEPHONE NO: AREA CODE () _____

FAX NO: AREA CODE () _____

EMAIL ADDRESS _____

The work for which this Proposal is submitted is for the construction in accordance with these Contract Documents (including the payment of not less than the State general prevailing wage rates set forth herein), the Project Plans described below, including any addenda thereto, the Contract annexed hereto, and also in accordance with the California Department of Transportation Standard Plans 2010, Revised Standard Plans, the Standard Specifications 2010, Revised Standard Specifications, standard drawings from the Design and Improvement Standards Manual of the County of El Dorado, revised March 8, 1994 including Resolutions 199-91 and 58-94 to adopt changes to the Design and Improvement Standards Manual; the Labor Surcharge and Equipment Rental Rates in effect on the date the work is accomplished, and in accordance with the General Prevailing Wage rates. The Project Plans and Contract Documents for the work to be done are entitled:

**Patterson Drive and Missouri Flat Road Overlays
Contract No. PW 16-31119/CIP No. 72190/P&C No. 356-C1699
May 17, 2016**

County of El Dorado
Proposal
Page P-1

PATTERSON DRIVE AND MISSOURI FLAT ROAD OVERLAYS
CONTRACT No. PW 16-31119 / CIP No. 72190 / P&C No. 356-C1699

Bids are to be submitted for the entire work. The amount of the bid for comparison purposes will be the total of all the items.

The Bidder shall set forth for each unit basis item of work a unit price and a total for the item, and for each lump sum item a total for the item, all in clearly legible figures in the respective spaces provided for this purpose. In the case of unit basis items, the amount set forth under the "Item Total" column shall be the product of the unit price bid and the estimated quantity for the item.

In case of discrepancy between the item price and the total set forth for a unit basis item, the unit price shall prevail, except as provided in (a) or (b), as follows:

- (a) If the amount set forth as a unit price is unreadable or otherwise unclear, or is omitted, or is the same as the amount as the entry in the item total column, then the amount set forth in the total column for the item shall prevail and shall be divided by the estimated quantity for the item and the price thus obtained shall be the unit price;
- (b) (Decimal Errors) If the product of the entered unit price and the estimated quantity is exactly off by a factor of ten, one hundred, etc., or one-tenth, or one-hundredth, etc., from the entered total, the discrepancy will be resolved by using the entered unit price or item total, whichever most closely approximates percentage wise the unit price or item total in the Community Development Agency, Transportation Division's Final Estimate of cost.

If this Proposal is accepted and the undersigned Bidder shall fail to enter into the Contract and furnish the two bonds in the sums required by the State Contract Act, with surety satisfaction to the County of El Dorado and in accordance with the Special Provisions within ten (10) days, not including Saturdays, Sundays, and legal holidays, of the date of the letter notice from the County of El Dorado that the Contract has been awarded, the County of El Dorado may, at its option, determine that the Bidder has abandoned the Contract, and thereupon this Proposal and the acceptance thereof shall be null and void and the forfeiture of such security accompanying this Proposal shall operate and the same shall be the property of the County of El Dorado.

The undersigned, as Bidder, declares under penalty of perjury under the laws of the State of California that the only persons or parties interested in this Proposal, as principals, are those named herein; that this Proposal is made without collusion with any other person, firm, or corporation; that it has carefully examined the location of the proposed work, the annexed proposed form of Contract, and the Plans therein referred to; and that it proposes, and agrees if this Proposal is accepted, that it will contract with the County of El Dorado, in the form of the copy of the Draft Contract annexed hereto, to provide all necessary machinery, tools, apparatus, and other means of construction, and to do all the work and furnish all the materials specified in the Contract, in the manner and time therein prescribed, and according to the requirements of the Engineer as therein set forth, and that it will take in full payment therefore the following item prices, to wit:

**PROPOSAL PAY ITEMS AND BID PRICE SCHEDULE
PATTERSON DRIVE AND MISSOURI FLAT ROAD OVERLAYS PROJECT
CONTRACT NO. PW 16-31119/CIP NO. 72190/P&C No. 356-C1699**

ITEM NO.	ITEM CODE	ITEM DESCRIPTION	UNIT OF MEASURE	ESTIMATED QUANTITY	UNIT PRICE (IN FIGURES)	ITEM TOTAL (IN FIGURES)
1	070030	LEAD COMPLIANCE PLAN	LS	1		
2	120100	TRAFFIC CONTROL SYSTEM	LS	1		
3	128651A	PORTABLE CHANGEABLE MESSAGE SIGN	SWD	70		
4	130100	JOB SITE MANAGEMENT	LS	1		
5	141103	REMOVE YELLOW THERMOPLASTIC TRAFFIC STRIPE (HAZERDOUS WASTE)	LF	656		
6	149001A	PREPARE FUGITIVE DUST CONTROL PLAN	LS	1		
7	152438A	ADJUST FRAME AND COVER TO GRADE (WATER VALVE)(EID REIMBURSEMENT)	EA	10		
8	152438B	ADJUST FRAME AND COVER TO GRADE (MANHOLE)(EID REIMBURSEMENT)	EA	26		
9	153103A	COLD PLANE ASPHALT CONCRETE PAVEMENT (CONFORM GRIND)	SQYD	15500		
10	153103B	COLD PLANE ASPHALT CONCRETE PAVEMENT (PROFILE GRIND)	SQYD	11875		
11	390132	HOT MIX ASPHALT (TYPE A)	TON	3750		
12	393006	P GEOSYNTHETIC PAVEMENT INTERLAYER (PAVING GRID)	SQYD	27375		
13	840504	4" THERMOPLASTIC TRAFFIC STRIPE	LF	26200		
14	840506	8" THERMOPLASTIC TRAFFIC STRIPE	LF	270		
15	840515	THERMOPLASTIC PAVEMENT MARKING	SQFT	1100		
16	850111	P PAVEMENT MARKER (RETROREFLECTIVE)	EA	560		
17	860090	MAINTAINING EXISTING TRAFFIC MANANGEMENT SYSTEM ELEMENTS DURING CONSTRUCTION	LS	1		

ITEM NO.	ITEM CODE	ITEM DESCRIPTION	UNIT OF MEASURE	ESTIMATED QUANTITY	UNIT PRICE (IN FIGURES)	ITEM TOTAL (IN FIGURES)
18	861501	MODIFY SIGNAL AND LIGHTING	LS	1		
19	999990	MOBILIZATION	LS	1		
TOTAL BID						

(F) Final Pay Quantity

(P) Eligible for Partial Payment

(LS) Lump Sum

(NOTICE: Bidders failure to execute the questionnaires and statements contained in this proposal as required by applicable laws and regulations, or the determinations by County of El Dorado based upon those questionnaires and statements, may prohibit award of the subject Contract to the bidder.)

SUBCONTRACTOR LIST

The Bidder must list the name, address, and license number, of each subcontractor to whom the Bidder proposes to subcontract portions of the work, as required by the provisions in section 2-1.33 The Bidder must also list the work portion to be performed by each subcontractor by listing the bid item number, bid item description, and portion of the work to be performed by the subcontractor in the form of a percentage calculated by dividing the work to be performed by the subcontractor by the respective bid item amount(s) (not by the total bid price).

Name	Location of Business	License No.	Bid Item Number and Bid Item Description	Percentage of Each Bid Item Subcontracted

Public Contract Code Section 10285.1 Statement

In conformance with Public Contract Code Section 10285.1 (Chapter 376, Stats. 1985), the Bidder hereby declares under penalty of perjury under the laws of the State of California that the Bidder has _____, has not _____ been convicted within the preceding three years of any offenses referred to in that section, including any charge of fraud, bribery, collusion, conspiracy, or any other act in violation of any state or Federal antitrust law in connection with the bidding upon, award of, or performance of, any public works contract, as defined in Public Contract Code Section 1101, with any public entity, as defined in Public Contract Code Section 1100, including the Regents of the University of California or the Trustees of the California State University. The term "Bidder" is understood to include any partner, member, officer, director, responsible managing officer, or responsible managing employee thereof, as referred to in Section 10285.1.

Note: The Bidder must place a check mark after "has" or "has not" in one of the blank spaces provided. The above Statement is part of the Proposal. Signing this Proposal on the signature portion thereof shall also constitute signature of this Statement. Bidders are cautioned that making a false certification may subject the certifier to criminal prosecution.

Public Contract Code Section 10162 Questionnaire

In conformance with Public Contract Code Section 10162, the Bidder shall complete, under penalty of perjury, the following questionnaire:

Has the Bidder, any officer of the Bidder, or any employee of the Bidder who has a proprietary interest in the Bidder, ever been disqualified, removed, or otherwise prevented from bidding on, or completing a federal, state, or local government project because of a violation of law or a safety regulation?

Yes _____ No _____

If the answer is yes, explain the circumstances in the following space.

Public Contract Code Section 10232 Statement

In conformance with Public Contract Code Section 10232, the Bidder, hereby states under penalty of perjury under the laws of the State of California, that no more than one final unappealable finding of contempt of court by a Federal Court has been issued against the Bidder within the immediately preceding two year period because of the Bidder's failure to comply with an order of a Federal Court which orders the Bidder to comply with an order of the National Labor Relations Board.

Note: The above Statement and Questionnaire are part of the Proposal. Signing this Proposal on the signature portion thereof shall also constitute signature of this Statement and Questionnaire. Bidders are cautioned that making a false certification may subject the certifier to criminal prosecution.

NONCOLLUSION AFFIDAVIT

(Title 23 United States Code Section 112 and
Public Contract Code Section 7106)

In conformance with Title 23 United States Code Section 112 and Public Contract Code 7106 the Bidder declares that the bid is not made in the interest of, or on behalf of, any undisclosed person, partnership, company, association, organization, or corporation; that the bid is genuine and not collusive or sham; that the Bidder has not directly or indirectly induced or solicited any other bidder to put in a false or sham bid, and has not directly or indirectly colluded, conspired, connived, or agreed with any bidder or anyone else to put in a sham bid, or that anyone shall refrain from bidding; that the Bidder has not in any manner, directly or indirectly, sought by agreement, communication, or conference with anyone to fix the bid price of the bidder or any other bidder, or to fix any overhead, profit, or cost element of the bid price, or of that of any other bidder, or to secure any advantage against the public body awarding the Contract of anyone interested in the proposed Contract; that all statements contained in the bid are true; and, further, that the Bidder has not, directly or indirectly, submitted his or her bid price or any breakdown thereof, or the contents thereof, or divulged information or data relative thereto, or paid, and will not pay, any fee to any corporation, partnership, company association, organization, bid depository, or to any member or agent thereof to effectuate a collusive or sham bid.

Note: The above Noncollusion Affidavit is part of the Proposal. Signing this Proposal on the signature portion thereof shall also constitute signature of this Noncollusion Affidavit.
Bidders are cautioned that making a false certification may subject the certifier to criminal prosecution.

Accompanying this proposal is _____

(NOTICE: INSERT THE WORDS "CASH(\$___), "CASHIER'S CHECK," "CERTIFIED CHECK," OR "BIDDERS BOND," AS THE CASE MAY BE)

in amount equal to at least ten percent of the amount of the total bid.

The names of all persons interested in the forgoing Proposal as principals are as follows:

IMPORTANT NOTICE: If the Bidder or other interested person is a corporation, state legal name of corporation and place of incorporation, also names of the president, secretary, treasurer, and executive officer thereof; if a partnership, state name of partnership, also names of all individual partners; if Bidder or other interested person is an individual, state first and last names in full.

Licensed in accordance with an act providing for the registration of Contractors,

License No. _____ Classification(s) _____

(A Copy of the afore-referenced license must be attached hereto.)

ADDENDA: This Proposal is submitted with respect to the changes to the Contract included in addenda number (s) _____

(Fill in addenda numbers if addenda have been received and insert, in this Proposal, any Proposal Pay Items and Bid Price Schedules that were received as part of the addenda)

By my signature on this Proposal I certify, under penalty of perjury under the laws of the State of California, that the foregoing questionnaire and statements of Public Contract Code Sections 10162, 10232, and 10285.1 are true and correct and that the Bidder has complied with the requirements of Sections 4104 of the Subletting and Subcontracting Fair Practices Act and of Section 8103 of the Fair Employment and Housing Commission Regulations (Chapter 5 of Division 4 of Title 2 of the California Code of Regulations). By my signature on this Proposal I further certify, under penalty of perjury under the laws of the State of California and the United States of America, that the Noncollusion Affidavit required by Title 23 United States Code, Section 112 and Public Contract Code Section 7106 are true and correct.

The person or persons executing this Proposal on behalf of a corporation or partnership shall be prepared to demonstrate by resolution, article, or otherwise, that such person is or that such persons are appropriately authorized to act in these regards for such corporation or partnership. Such authority shall be demonstrated to the satisfaction of the County of El Dorado.

If the signature is by an agent other than an officer of a corporation or a member of a partnership, a power of attorney authorizing said act by the agent on behalf of his principal shall be submitted with the bid forms; otherwise, the bid may be disregarded as irregular and unauthorized.

The Bidder's execution on the signature portion of this Proposal shall constitute an endorsement and execution of those affidavits, declarations and certifications which are part of this Proposal.

Executed this _____ day of _____, 20__

at _____ County, State of _____



Name and Title of Bidder _____

Name of Firm _____

COUNTY OF EL DORADO

BIDDER'S BOND

this form MUST be used

KNOW ALL PEOPLE BY THESE PRESENTS, THAT WE _____
_____, as **PRINCIPAL**, and

as Surety are held and firmly bound unto the County of El Dorado, a political subdivision of the State of California (hereinafter referred to as "Obligee"), in the penal sum of **TEN (10) PERCENT OF THE AMOUNT OF THE TOTAL BID PRICE** of the Principal above named, submitted by said Principal to the Obligee for the work described below, for the payment of which sum in lawful money of the United States, well and truly to be made to the Obligee, we the Principal and Surety bind ourselves, our heirs, executors, administrators and successors, jointly and severally, firmly by these presents. In no case shall the liability of the Surety hereunder exceed the sum of

TEN PERCENT (10%) OF THE AMOUNT OF THE TOTAL BID PRICE

THE CONDITION OF THIS OBLIGATION IS SUCH, THAT:

WHEREAS, the Principal has submitted the above-mentioned Bid to the Obligee, as aforesaid, for certain construction specifically described as follows, for which bids are to be opened at Placerville, El Dorado County, California, for the construction of the

**PATTERSON DRIVE AND MISSOURI FLAT ROAD OVERLAYS
CONTRACT No. PW 16-31119 / CIP No. 72190 / P&C 356-1699**

NOW, THEREFORE, if the aforesaid Principal is awarded the Contract and, within the time and manner required under the Contract Documents, after the prescribed forms are presented to it for signature, enters into a written contract, in the prescribed form, in accordance with the Bid, and files two bonds with the Obligee, one to guarantee faithful performance and the other to guarantee payment for labor and materials, as required by law, then this obligation shall be null and void; otherwise, it shall remain in full force and virtue.

In the event suit is brought upon this bond by the Obligee and judgment is recovered, the Surety shall pay all costs incurred by the Obligee in such suit, including a reasonable attorney's fee to be fixed by the Court.

IN WITNESS WHEREOF, we have set our hands and seals on this _____ day of _____ 20__

(seal) _____
Principal

(seal) _____
Surety

Address: _____

(NOTE: Signature of those executing for the Surety shall be properly acknowledged, and accompanied by a Certificate of Acknowledgment.)

SURETY

ACKNOWLEDGMENT

A notary public or other officer completing this certificate verifies only the identity of the individual who signed the document to which this certificate is attached, and not the truthfulness, accuracy, or validity of that document.

State of California

County of _____

On _____ before me, _____,
(here insert name and title of the officer)

personally appeared _____

_____ ,

who proved to me on the basis of satisfactory evidence to be the person(s) whose name(s) is/are subscribed to the within instrument and acknowledged to me that he/she/they executed the same in his/her/their authorized capacity(ies), and that by his/her/their signature(s) on the instrument the person(s), or the entity upon behalf of which the person(s) acted, executed the instrument.

I certify under PENALTY OF PERJURY under the laws of the State of California that the foregoing paragraph is true and correct.

WITNESS my hand and official seal.

Signature _____

(Seal)