

**CONTRACT CHANGE ORDER**

Change Requested by:	<input checked="" type="checkbox"/> Engineer	<input type="checkbox"/> Contractor
----------------------	--	-------------------------------------

CCO No. 4	Suppl. No.	Contract No. 78713	Road 2017 Mt. Aukum Rd Sinkhole	Federal Number(s) ER-32LO(034)
--------------	------------	-----------------------	------------------------------------	-----------------------------------

To **Lamon Construction Company, Inc.** ,Contractor

You are directed to make the following changes from the plans and specifications or do the following described work not included in the plans and specifications for this contract. NOTE: This change order must be approved by the Board of Supervisors:  Yes  No

Description of work to be done, estimate of quantities and prices to be paid. (Segregate between additional work at contract price, agreed price and force account.) The last percentage shown is the net accumulated increase or decrease from the original quantity in the Engineer's Estimate

In accordance with Section 4-1.05, *Changes and Extra Work*, of the Standard Specifications, replace the "Trench Section" detail on contract Plan sheet "D-1, *Drainage System 'SD1'*" with the attached revised "Trench Section" detail.

**Extra Work at Agreed Lump Sum Price**

As directed by the Engineer, provide all additional labor, equipment, and materials necessary to install 138-feet of the revised trench section underdrain from Headwall No. 1 to a point that is approximately 20-feet down pipe from Headwall No. 2. Install two separate 10-foot lengths of 6-inch perforated underdrain pipe thru Headwall No. 1 to transmit the groundwater into the adjacent rock lined ditch. For this work, the Contractor shall receive and accept \$45,369.00. This sum constitutes full and complete compensation for providing all labor, material, equipment, tools, and incidentals, including all markups by reason of this change.

Total Cost.....\$45,369.00

**Payment Adjustment at Agreed Lump Sum (Credit)**

In accordance with Section 4-1.05B, *Work -Character Changes*, of the Standard Specifications, eliminate the "6" AB BEDDING" shown on the "Trench Section" detail on Plan Sheet "D-1, *Drainage System 'SD1'*." In lieu of the AB bedding, place ¾-inch crushed rock as shown on the revised "Trench Section" detail shown on Sheet 3 of this contract change order. Payment for the crushed rock is included in the extra work at agreed lump sum price detailed above.

For the elimination of the AB bedding described above, the Contractor will credit the County the lump sum amount of \$858.00. This credit represents full and complete compensation for providing all labor, material, equipment, tools, and incidentals, including all markups by reason of this change.

Total Decrease.....<\$858.00>

**Decrease Contract Item at Contract Item Price**

In accordance with Section 4-1.05, *Changes and Extra Work*, and Section 9-1.06, *Changed Quantity Payment Adjustments*, of the Standard Specifications, eliminate Bid Item No. 12.

Item 12- Structure Backfill (Slurry Cement).....-35 CY (-100%) @ \$258.00 / .....<\$9,030.00> (-100%)

Total Decrease in Contract Item.....<\$9,030.00>

In accordance with Section 9-1.06D, *"Eliminated Items,"* of the Standard Specifications, the adjustment due to the elimination of the Bid Item 12, Structure Backfill (Slurry Cement), is zero.



**EL DORADO COUNTY  
DEPARTMENT OF TRANSPORTATION  
CONTRACT CHANGE ORDER**

Contract No.: 78713      CCO No.: 04

No Additional Text In This Section

Estimated Cost:  Decrease     Increase      \$35,481.00

By reason of this order the time of completion will be adjusted as follows: **Five (5) Working Days**

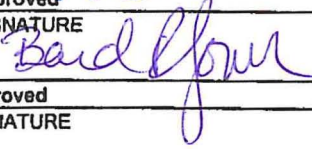
<b>Submitted by</b>		
SIGNATURE 	(PRINT NAME & TITLE) Aradhana Kochar, P.E., Resident Engineer	DATE 7-14-17
<b>Approved</b>		
SIGNATURE 	(PRINT NAME & TITLE) John Kahling, P.E., Deputy Director, Engineering	DATE 07/31/17
<b>Approved</b>		
SIGNATURE 	(PRINT NAME & TITLE) Bard R. Lower, Interim Director of Transportation	DATE 7/31/17
<b>Approved</b>		
SIGNATURE	(PRINT NAME & TITLE) Shiva Frentzen, Chair Board of Supervisors	DATE

We the undersigned contractor, have given careful consideration to the change proposed and agree, if this proposal is approved, that we will provide all equipment, furnish the materials, except as may otherwise be noted above, and perform all services necessary for the work above specified, and will accept as full payment therefor the prices shown above. The prices and terms of payment shown above comprise full and final compensation for all direct costs, indirect costs, cumulative costs, and all overhead costs incurred as a result of this contract change order. NOTE: If you, the contractor, do not sign acceptance of this order, your attention is directed to the requirements of the specification as to proceeding with the ordered work and filing a written protest within the time therein specified.

<b>Contractor Acceptance by</b>		
SIGNATURE 	(PRINT NAME & TITLE) STEVE H. W. BURN	DATE 7/12/17

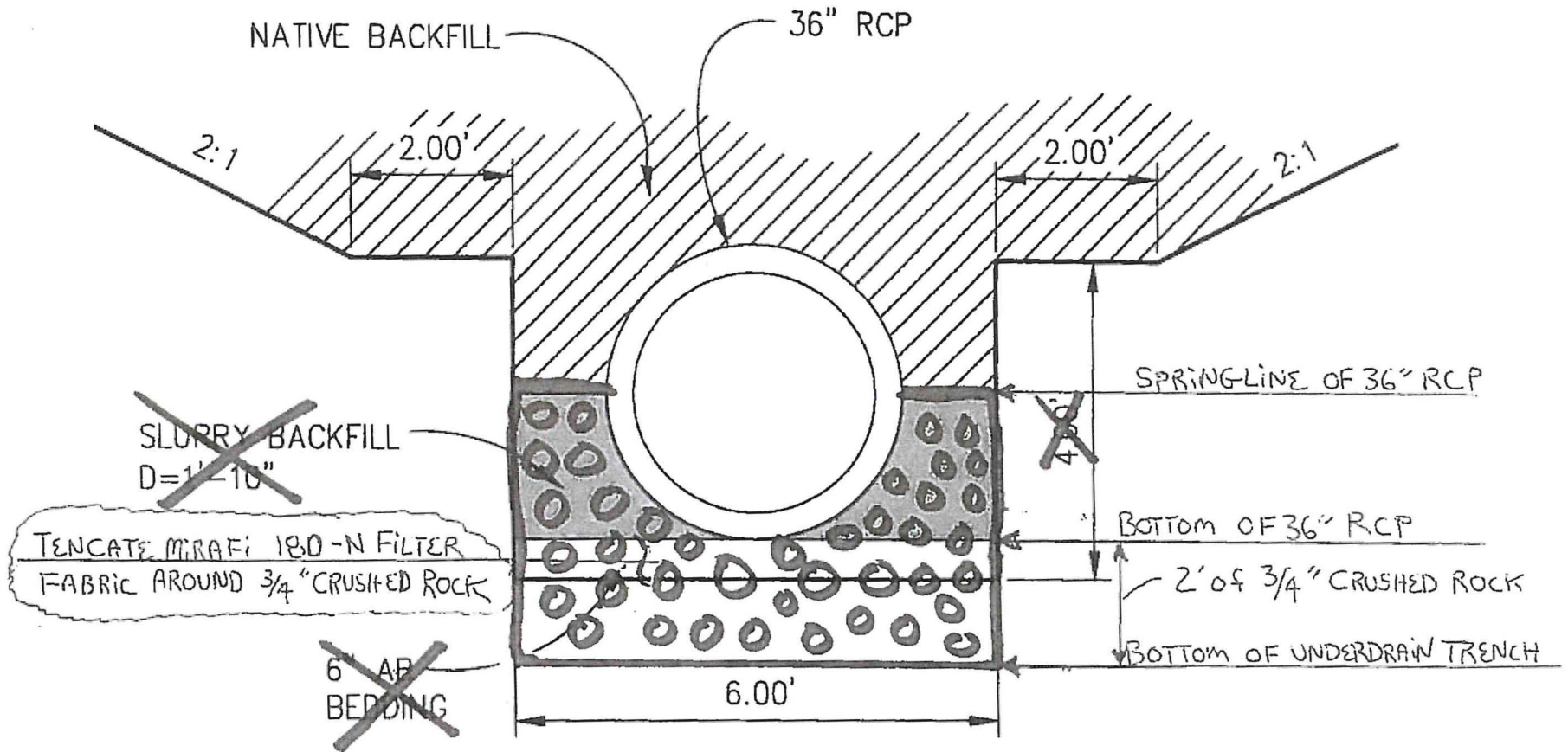

# TRENCH SECTION

## PROJECT:

2017 MT. AUKUM RD. SINKHOLE  
 Contract No. PW 17-31155;  
 CIP No. 78713; P&C No. 443-C1799;  
 Federal-Aid No.: ER-32LO(034)

**CCO NO. 4; REVISED TRENCH SECTION UNDERDRAIN (PAGE 3 OF 3)**



PAGE 3 of 3