

**COUNTY OF EL DORADO, CALIFORNIA
DEPARTMENT OF TRANSPORTATION**

CONTRACT DOCUMENTS

INCLUDING
NOTICE TO BIDDERS, SPECIAL PROVISIONS,
PROPOSAL, AND AGREEMENT
FOR

**SLT FUEL TANK AND DISPENSER INSTALLATION AND
REMOVAL OF EXISTING SYSTEM**

CONTRACT NO. 10197

FOR USE WITH
STATE OF CALIFORNIA, DEPARTMENT OF TRANSPORTATION,
2024 STANDARD SPECIFICATIONS AND STANDARD PLANS

BID OPENING DATE: MAY XX, 2026

COUNTY OF EL DORADO, STATE OF CALIFORNIA
DEPARTMENT OF TRANSPORTATION
SLT FUEL TANK AND DISPENSER INSTALLATION
AND REMOVAL OF EXISTING SYSTEM

Contract No. 10197

Table of Contents

NOTICE TO BIDDERS	N-1
SAMPLE AGREEMENT	A-1
EXHIBIT A.....	A-28
EXHIBIT B.....	B-1
EXHIBIT C.....	C-1
PAYMENT BOND	NO PAGE NUMBER
PERFORMANCE BOND	NO PAGE NUMBER
PROPOSAL	P-1
BIDDER'S BOND	NO PAGE NUMBER
DRUG-FREE WORKPLACE CERTIFICATION	NO PAGE NUMBER

**COUNTY OF EL DORADO, CALIFORNIA
DEPARTMENT OF TRANSPORTATION**

NOTICE TO BIDDERS

NOTICE IS HEREBY GIVEN by the County of El Dorado, State of California, that bids submitted through Quest for Work in accordance with the Project Plans (Plans) and Contract Documents designated:

**SLT FUEL TANK AND DISPENSER INSTALLATION AND REMOVAL OF EXISTING
SYSTEM
CONTRACT NO. – 10197**

Will be received by the County of El Dorado, Department of Transportation through Quest Construction Data Network (Quest), until **May XX, 2026 at 2:00 PM**, at which time bids will be publicly opened and read by the Department of Transportation. The bid opening will be held virtually through Microsoft Teams. The virtual meeting can be accessed via the following: <https://tinyurl.com/ShakoriFuelPad> / Meeting ID: 239 956 629 998 8 / Passcode: dW2Cd7gw / Dial in number: 530-447-0967 / Phone conference ID: 872 339 327#.

No Bid may be withdrawn after the time established for receiving bids or before the award and execution of the Contract, unless the award is delayed for a period exceeding sixty (60) calendar days. Bids must be executed in accordance with the instructions given and forms provided in the Contract Documents furnished by the County of El Dorado, Department of Transportation through Quest. **The Proposal including the Form 590, Payee Data Form, Bidder's Security, and any other required documents shall be submitted through Quest.**

LOCATION/DESCRIPTION OF THE WORK: The project is located in the South Lake Tahoe, CA. The Work to be done is shown in Exhibits A and B and generally consists of, but is not limited to:

- A. The removal of existing concrete pad, dispensing system and underground tanks. Installation of two (2) new aboveground UL-2085 Fireguard tanks and dispensing system in accordance with all permitting requirements. Pour new concrete pad to match existing infrastructure and installation of eight (8) reinforced steel surrounded by 4" bollards. Other items or details not mentioned above, that are required by the Contract Documents must be performed, constructed, or installed.
- B. All work listed in Schedule A related to the installation of the new aboveground tanks and dispensing system shall be completed prior to October 1, 2026. All work listed in Schedule B related to the removal of the existing system ideally would be completed prior to October 1, 2026, however it shall be completed no later than June 30, 2027 should weather conditions or time not allow for removal in calendar year 2026.
- C. Bids are required for the entire Work described.
- D. The Contract time is ONE HUNDRED FIFTY (150) WORKING DAYS.
- E. For bonding purposes the anticipated project cost is estimated at \$394,310.00.
- F. A pre-bid meeting is scheduled for this project on **May XX, 2026 at 2:00 p.m.** Attendance at the pre-bid meeting is not mandatory. The pre-bid meeting will be held simultaneously at two County locations as follows:
 - 2441 Headington Road, Placerville, CA.
 - 1121 Shakori Drive, South Lake Tahoe, CA
- G. This project is being bid formally in accordance with Public Contract Code Section 22032 and County of El Dorado Ordinance Code section 3.14.040.

OBTAINING OR VIEWING CONTRACT DOCUMENTS: The Contract Documents, including the Project Plans, may be viewed and/or downloaded from the Quest website at <http://www.questcdn.com>. Interested parties may also access the Quest website by clicking on the link next to the Project Name or entering the Quest project #9533522 on the Department of Transportation's website at: <http://www.edcgov.us/government/DOT/pages/BidsHome.aspx>.

Interested parties may view the Contract Documents, including the Project Plans, on the Quest website at no charge. The digital Contract Documents, including the Project Plans, may be downloaded for \$42.00 by inputting the Quest project #9811559 on the websites' Project Search page. Please contact QuestCDN.com at (952) 233-1632 or info@questcdn.com for assistance in free membership, registration, downloading, and working with this digital project information. To access the electronic bid form, download the project/request documents and click the online bidding button at the top of the advertisement screen.

To be included on the planholders list, receive notification of addenda, and to be eligible to bid interested parties must pay for and download the Contract Documents, including the Project Plans, from Quest. Those downloading the Contract Documents, including the Project Plans, assume responsibility and risk for completeness of the downloaded Contract Documents.

The Contract Documents, including the Project Plans, may be examined in person at the Department of Transportation's office at 2850 Fairlane Court, Placerville CA. However the Department of Transportation will no longer sell paper copies of the Contract Documents.

PUBLIC RECORDS ACT: All bids and other materials submitted as part of the process, including review of DBE materials, become the property of the County and are subject to release according to the California Public Records Act (Government Code Section 7920.000, et seq.).

If a Bidder believes that any portion of its Bid or other materials submitted is exempt from public disclosure, Bidder must indicate the specific portions believed to be confidential and not subject to disclosure on Attachment I – Public Records Act Exemptions at the same time that the Bid or other materials are provided to the County. The Bidder also must include a brief description that sets out the reasons for exemption from disclosure. Each stated exemption must include a citation to supporting legal authority, including statutory authority or case law, to support exemption from the Public Records Act. County will not consider any requested exemptions that do not meet the requirements of this section and will treat the bid or other materials submitted as non-exempt public records.

The County will use reasonable means to ensure that such information is safeguarded but will not be held liable for inadvertent disclosure of the information. Proposals marked "Confidential" in their entirety will not be honored, and the County might not deny public disclosure of any portion of Proposals so marked.

By submitting a Bid or other materials with portions identified in Attachment I as "Confidential," Bidder represents that it has a good faith belief that such portions are exempt from disclosure under the Public Records Act. Bidder may be requested to obtain legal protection from disclosure should a Public Records Act request be received. In the event the County does not disclose the information marked "Confidential," Bidder agrees to reimburse the County for, and to indemnify, defend (with counsel approved by County) and hold harmless the County, its officers, employees, agents, and volunteers from and against any and all claims, damages, losses, liabilities, suits, judgments, fines, penalties, costs and expenses, including without limitation, attorneys' fees, expenses and court costs of any nature arising from or relating to the County's non-disclosure of any such designated portions of the Bid or other materials.

CONTRACTORS LICENSE CLASSIFICATION: Bidders must be properly licensed to perform the Work pursuant to the Contractors' State License Law (Business and Professions Code Section 7000, et seq.) and must possess a **CLASS A** license or equivalent combination of Classes required by the categories and type of Work included in the Contract Documents and Plans at the time the Contract is awarded, and must maintain a valid license through completion and acceptance of the Work, including the guarantee and acceptance period. Failure of the successful Bidder to obtain proper adequate licensing will constitute a failure to execute the Contract and will result in the forfeiture of the Bidder's security.

BUSINESS LICENSE: The County Business License Ordinance provides that it is unlawful for any person to furnish supplies or services or transact any kind of business in the unincorporated territory of County of El Dorado without possessing a County business license unless exempt under County Ordinance Code Section 5.08.070. The Bidder to whom an award is made must comply with all of the requirements of the County Business License Ordinance, where applicable, prior to beginning Work under this contract and at all times during the term of this Contract.

CONTRACTOR REGISTRATION: No contractor or subcontractor may bid on any public works project, be listed in a bid proposal for any public works project, or engage in the performance of any contract for public work unless registered with the Department of Industrial Relations pursuant to Labor Code Sections 1725.5 and 1771.1.

An inadvertent error in listing a subcontractor who is not registered pursuant to Section 1725.5 in a bid proposal shall not be grounds for filing a bid protest or grounds for considering the bid nonresponsive if the requirements of Labor Code Section 1771.1 are met.

SUBCONTRACTOR LIST: Each Proposal must have listed therein the name, contractor's license number, DIR number, and address of each subcontractor to whom the bidder proposes to subcontract portions of the work in an amount in excess of 0.5% of the total bid or \$10,000, whichever is greater, in accordance with the Subletting and Subcontracting Fair Practices Act, commencing with Section 4100 of the Public Contract Code. The Bidder must also describe in the Subcontractor List the work to be performed by each subcontractor listed. The work to be performed by the subcontractor must be shown by listing the bid item number, bid item description, and portion of the work to be performed by the subcontractor in the form of a percentage (not to exceed 100%) calculated by dividing the work to be performed by the subcontractor by the respective bid item amount(s) (not by the total bid price).

The percentage of each bid item subcontracted may be submitted with the Bidder's bid or sent via email or fax to Jen Rimoldi, Department of Transportation, email- jennifer.rimoldi@edcgov.us, Fax-(530) 626-0387 by 4:00 p.m. on the first business day after the bid opening. The email or fax must contain the name of each subcontractor submitted with the Bidder's bid along with the bid item number, the bid item description, and the percentage of each bid item subcontracted, as described above. At the time bids are submitted, all listed subcontractors must be properly licensed to perform their designated portion of the work. The bidder's attention is directed to other provisions of the Act related to the imposition of penalties for failure to observe its provisions by using unauthorized subcontractors or by making unauthorized substitutions.

An inadvertent error in listing the California Contractor license number on the Subcontractor List will not be grounds for filing a bid protest or grounds for considering the bid non-responsive if the Bidder submits the corrected contractor's license number to Jen Rimoldi via fax or email as noted above within 24 hours after being requested by the Department, provided the corrected contractor's license number corresponds to the submitted name and location for that subcontractor.

DISADVANTAGED BUSINESS ENTERPRISE (DBE) PARTICIPATION: The County of El Dorado affirms that in any contract entered into pursuant to this advertisement, disadvantaged business enterprises will be afforded full opportunity to submit bids in response to this invitation.

NONDISCRIMINATION: Bidders must comply with Subchapter 5 of Chapter 5 of Division 4.1 of Title 2, California Code of Regulations and the following.

**NOTICE OF REQUIREMENT FOR NONDISCRIMINATION PROGRAM
(GOVERNMENT CODE SECTION 12990)**

Comply with Section 7-1.021(2), "Nondiscrimination," of the Standard Specifications, which is applicable to all nonexempt State contracts and subcontracts, and to the "Standard California Nondiscrimination Construction Contract Specifications" set forth therein. The specifications are applicable to all nonexempt State construction contracts and subcontracts of \$5,000 or more.

PREVAILING WAGE REQUIREMENTS: In accordance with the provisions of Labor Code Sections 1770, et seq., including but not limited to Sections 1773, 1773.1, 1773.2, 1773.6, and 1773.7, the general prevailing rate of wages in the county in which the Work is to be done has been determined by the Director of the California Department of Industrial Relations. Interested parties can obtain the current wage information by submitting their requests to the Department of Industrial Relations, Division of Labor Statistics and Research, PO Box 420603, San Francisco CA 94142-0603, Telephone (415) 703-4708 or by referring to the website at <http://www.dir.ca.gov/OPRL/PWD>. The rates at the time of the bid advertisement date of a project will remain in effect for the life of the project in accordance with the California Code of Regulations, as modified and effective January 27, 1997.

Copies of the general prevailing rate of wages in the county in which the Work is to be done are also on file at the Department of Transportation's principal office and are available upon request.

In accordance with the provisions of Labor Code Section 1810, eight (8) hours of labor constitutes a legal day's work upon all work done hereunder, and Contractor and any subcontractor employed under the Contract must conform to and be bound by the provisions of Labor Code Sections 1810 through 1815.

This project is subject to the requirements of Title 8, Chapter 8, Subchapter 4.5 of the California Code of Regulations including the obligation to furnish certified payroll records directly to the Compliance Monitoring Unit under the Labor Commissioner within the Department of Industrial Relations Division of Labor Standards Enforcement in accordance with Section 16461.

EMISSIONS REDUCTION: Contractor must comply with emission reduction regulations mandated by the California Air Resources Board (CARB) and sign the certification of knowledge in the Agreement. Contractor must require all sub-contractors to comply with such regulations. Consistent with 13 CCR 2449(i), the successful Contractor must submit to the County current CARB Certificates for any applicable fleet intended to be used by the Contractor and for any applicable fleet intended to be used by all subcontractors listed on the Subcontractor Listing Form in the Proposal within ten (10) business days of receiving the Notice to Award Letter. Failure to send those certificates may result in forfeiture of your bidder's bond, and the County reserves the right to then award the Project to the next lowest responsive and responsible bidder.

BID SECURITY: A bid security must be provided with each bid. Bid security must be in an amount of not less than ten percent (10%) of the total amount of the Bid for bid and must be cash, a certified check or cashier's check drawn to the order of the County of El Dorado or a Bidder's Bond executed by a surety satisfactory to the County of El Dorado **on the form provided in the Proposal section of these Contract Documents.**

Bidders are required to submit either an electronic Bidder's Bond through Surety2000 or a PDF copy of a hard copy Bidder's Bond with their bid. If a bid security other than a Bidder's Bond is being used, Bidders must upload a PDF copy of the bid security with their electronic bid submittal. If a PDF copy of the bid security is uploaded, the original bid security must be provided to the Department of Transportation after the bid opening but before the end of business on the first business day after the bid opening. If Bidder chooses to utilize Surety2000, by submitting their bid, Bidder hereby agrees to hold the County of El Dorado harmless from and waive any and all claims against the County of El Dorado for any claims or damages that arise from or are related to the Bidder's use of Surety2000.

BID PROTEST PROCEDURE: The protest procedure is intended to handle and resolve disputes related to the bid award for this project pursuant to County of El Dorado policies and procedures. Only a contractor who submitted a bid may file a bid protest.

The protest procedure is an extension of the bid process and allows those who wish to protest the recommendation of an award after bid the opportunity to be heard.

Policy: Upon completion of the bid evaluation, the Department of Transportation shall notify all bidders of the recommendation of award, the basis therefore, and the date on which the recommendation for award will be considered and acted upon by the Board of Supervisors.

Procedure: If a bidder wishes to protest the award, the procedure shall be as follows:

1. The Department of Transportation will review the bids received in a timely fashion under the terms and conditions of the Notice to Bidders, and notify the bidders in writing, at the Fax number designated in the bid, of its recommendation including for award or rejection of bids ("All Bidders Letter").
2. Within five (5) business days from the date of the "All Bidders Letter," the Bidder protesting the recommendation for award shall submit a letter of protest to the County of El Dorado, Department of Transportation, Attention Jen Rimoldi, 2441 Headington Road, Placerville, CA 95667, and state in detail the basis and reasons for the protest. The Bidder must provide facts to support the protest, including any evidence it wishes to be considered, together with the law, rule, regulation, or criteria on which the protest is based.
3. If the Department of Transportation finds the protest to be valid, it may modify its award recommendations and notify all bidders of that decision. If the Department of Transportation does not agree with the protest, or otherwise fails to resolve the protest, the Department of Transportation will notify the bid protestor and all interested parties of its decision and the date the award will be agendized for the Board of Supervisors' consideration and action. The Department of Transportation will also include in its report to the Board of Supervisors the details of the bid protest.
4. The Bidder may attend the Board of Supervisors meeting at which the recommendation and bid protest will be considered. The Board of Supervisors will take comment from the Bidder, staff, and members of the public who wish to speak on the item. In the event that the Bidder is not in attendance at that time, the bid protest may be dismissed by the Board of Supervisors without further consideration of the merits.

The decision of the Director of Transportation on the bid protest shall be final.

AWARD OF CONTRACT: Bids will be considered for award by the Director of Transportation. The County of El Dorado reserves the right after opening bids to reject any or all bids, to waive any irregularity in a bid, or to make award to the lowest responsive, responsible Bidder and reject all other bids, as it may best serve the interests of the County.

The Contract will be awarded based upon the total bid for all items listed in the Bid Schedule. The County reserves the right to reject all bids.

As a condition of award, the successful Bidder will be required to submit bonds and evidence of insurance prior to execution of the Agreement by the County. Failure to meet this requirement constitutes abandonment of the Bid by the Bidder and forfeiture of the Bidder's security. Award will then be made to the next lowest, responsive, responsible Bidder.

The Office Engineer must receive all required documents within ten (10) business days of the date of the Notice of Award of Contract letter.

RETAINAGE FROM PAYMENTS: The Contractor may elect to receive one hundred percent (100%) of payments due under the Contract from time to time, without retention of any portion of the payment by the County, by depositing securities of equivalent value with the County in accordance with the provisions of Section 22300 of the Public Contract Code. Securities eligible for deposit hereunder are limited to those listed in Section 16430 of the Government Code, or bank or savings and loan certificates of deposit.

PROJECT ADMINISTRATION: Submit all Requests for Information (RFI) during the bid period to the email address shown on the Quest website under the Quest #9811559 under "Project Q&A." If the response does not require an addendum, a response will be posted on the Quest website under the RFI under "Project Q&A". It is the bidders' responsibility to check this website under "Project Q&A" for responses to bidders' inquiries during the bid period. Addenda will be uploaded in pdf format to Quest's website and Quest will issue an automatic email notification to all planholders that have acquired the Contract Documents digitally through Quest. The list of planholders will be available on Quest's website under "View Planholders."

No oral responses to any questions concerning the content of the Contract Documents will be given. All responses will be in the form of written addenda to the Contract Documents or written responses to bidders' inquiries. Responses to bidders' inquiries and addenda will be posted on the Quest website as described above.

BY ORDER OF the Director of the Department of Transportation, County of El Dorado, State of California.

By _____
Rafael Martinez
Director, Department of Transportation



COUNTY OF EL DORADO DEPARTMENT OF TRANSPORTATION

AGREEMENT FOR CONSTRUCTION SERVICES

THIS AGREEMENT made and entered into by and between the **COUNTY OF EL DORADO**, a political subdivision of the State of California, acting through the governing body or board thereof (hereinafter referred to as “County”), and **CONTRACTOR**., duly qualified to conduct business in the State of California, whose principal place of business is (hereinafter referred to as “Contractor”);

RECITALS

WHEREAS, Contractor has duly submitted a bid proposal for the captioned project upon which County has awarded this contract;

That for and in consideration of the mutual promises, covenants, agreements, and conditions herein , the parties hereto agree with each other as follows:

1. Contract Documents

The complete Agreement between the parties consists of and is set forth in the Contract Documents. The Contract Documents consist of: (a) the Notice to Bidders; (b) the bid forms which include the accepted Proposal, Bid Price Schedule and Total Bid, Subcontractor List, Section 10285.1 Statement, Section 10162 Questionnaire, Section 10232 Statement, Drug Free Workplace Certification, Noncollusion Affidavit, the Contract which includes this Agreement with all Exhibits thereto, including, the Bidders’ Bond, Performance Bond, and Payment Bond; (c) the State of California Department of Transportation (Caltrans) Standard Plans 2024, and Standard Specifications 2024, the Manual of Uniform Traffic Control Devices (MUTCD), and standard drawings from the Design and Improvement Standards Manual of the County of El Dorado, revised March 8, 1994 including Resolution 199-91 and Resolution 58-94 to adopt changes to the Design and Improvement Standards Manual; (d) all Addenda incorporated in those documents before their execution, and all Contract Change Orders issued in accordance with the Contract Documents which may be delivered or issued after the Effective Date of this Agreement and are not attached hereto; (e) the prevailing Labor Surcharge And Equipment Rental Rates (when required) as determined by Caltrans to be in effect on the date the Work is accomplished; (f) executed Certificate of Insurance forms; (g) an executed Department of the Treasury Internal Revenue Service Form W-9 or County Payee Data Record Form, whichever is applicable; (h) all the obligations of County and of Contractor which are fully set forth and described therein; and all Contract Documents which are hereby specifically referred to and by such reference made a part hereof. All Contract Documents are intended to cooperate so that any work called for in one and not mentioned in the other is to be executed the same as if mentioned in all Contract Documents. Contractor agrees to perform all of its promises, covenants, and conditions set forth in the Contract Documents, and to abide by and perform all terms and conditions set forth therein. In case of conflict between this Agreement and any other contract document, this Agreement shall take precedence. In case of conflict between any contract documents other than this Agreement, the documents shall take precedence in the order identified above, beginning with (a) and ending with (h).

2. Execution of Contract

The successful Bidder must sign the *Agreement*.

Deliver to Office Engineer:

- 1) Two Original Signed *Agreements*

-
- 2) Contract Bonds
 - 3) Documents identified in Article 1
 - 4) Documents identified in the Notice of Award letter; and
 - 5) Current CARB Certificates for any applicable fleet intended to be used by the Contractor and for any applicable fleet intended to be used by all subcontractors.

Office Engineer must receive these documents within 10 business days of the date of the Notice of Award of Contract letter.

The Bidder's security may be forfeited for failure to execute the Contract, furnish any bond, or provide the required insurance documents within the time specified.

The Department does not provide hard copies of the Contract Documents, including the Project Plans to the successful bidder.

3. **The Work**

Contractor is engaged in the business of doing the services and tasks required by this Agreement. Contractor agrees to furnish, at Contractor's own cost and expense, all tools, equipment, vehicles, apparatus, facilities, labor, materials, supplies, and all utility and transportation services to perform and complete in a good and workmanlike manner, furnished and installed, and complete and ready for use. Services shall include, but not limited to, those tasks as identified in Exhibit B, marked "Project Plans," incorporated herein and made by reference a part hereof.

Work shall be completed for Schedule A by October 1, 2026, and Schedule B by June 30, 2027, in accordance with all the terms and conditions of the Contract Documents and in a safe, professional, skillful, and workmanlike manner. Contractor is responsible for ensuring that its employees, as well as any subcontractor if applicable, perform the services and tasks required under this Agreement accordingly.

4. **Location of Work**

Said work is to be performed at 1121 Shakori Drive, South Lake Tahoe, California 96150.

5. **Contract Price**

All bids will be compared on the basis of the Proposal Pay Items and Bid Price Schedule of the quantities of work to be done. The award of Contract, if it will be awarded, will be to the lowest responsive, responsible Bidder whose proposal complies with all the requirements prescribed. The lowest responsive, responsible Bidder will be the Bidder submitting the lowest total of all the bid items. In the event of a discrepancy between the unit price bid and the extended unit total as stated on the Proposal, the County uses the amount bid for the unit price in calculating the additive total of the bid items for purposes of award, including revisions by Addenda, and as specified in the Proposal instructions.

County hereby promises and agrees with said Contractor to employ, and does hereby employ, said Contractor to provide the material and to do the Work according to the terms and conditions of the Contract Documents herein contained and referred to, for the prices hereinafter set forth, and hereby contracts to pay the same at the time, in the manner and upon the conditions herein set forth; and the said parties for themselves, their heirs, executors, administrators, successors and assigns, do hereby agree to the full performance of the covenants herein contained. County shall pay Contractor for the completion of the Work in accordance with the Contract Documents in current funds the Contract Prices named in Contractor's Bid and Bid Price Schedule, a copy of which is attached hereto as Exhibit A.

6. **Time of Completion**

Time is of the essence, Work under the Contract shall be completed within ONE HUNDRED FIFTY (150) Working Days from the date specified in the official Notice to Proceed, unless an extension of time or suspension of Work is authorized in writing in accordance with a Contract Change Order. The contract working days begin on the date stated in the Notice to Proceed. The County will issue Notice to Proceed after Contract approval. Contract working hours are between the hours of 7:00 a.m. to 7:00 p.m.

County and Contractor recognize that time is of the essence of the Agreement and that County will suffer financial loss if the Work is not completed within the time specified in the Notice to Bidders annexed hereto and stated above plus any extensions thereof. They also recognize the delays, expense, and difficulties involved with proving in a legal proceeding the actual loss suffered by County if the Work is not completed on time. Accordingly, instead of requiring any such proof, County and Contractor agree that as liquidated damages for delay (but not as a penalty) Contractor shall pay County the sum of **THREE THOUSAND FIVE HUNDRED DOLLARS (\$3,500)**, as liquidated damages and not as a penalty, for each and every calendar days delay in finishing the Work in excess of the Contract time prescribed herein.

Any work that causes ground disturbance must be completed by October 15, 2026, and is unable to resume until May 1, 2027. Ground-disturbing activities include, but are not limited to:

- Removal of existing pavement, surfacing, or base
- Excavation, grading, and compaction; and
- Trenching or backfilling for utilities within the project limits, if applicable
-

Liquidated damages for not completing all work associated with any ground disturbing activities by October 15, 2026, for Schedule A are \$2,800 per day.

7. **Measurement and Payment**

Payment

The Department pays you for furnishing the resources and activities required to complete the work. The Department's payment is full compensation for furnishing the resources and activities, including:

1. Risk, loss, damage repair, or cost of whatever character arising from or relating to the work and performance of the work
2. PLACs and taxes
3. Any royalties and costs arising from patents, trademarks, and copyrights involved in the work

The Department does not pay for your loss, damage, repair, or extra costs of whatever character arising from or relating to the work that is a direct or indirect result of your choice of construction methods, materials, equipment, or manpower, unless specifically mandated by the Contract. Payment is:

1. Full compensation for all work involved in each bid item shown on the Bid Item List by the unit of measure shown for that bid item
2. For the price bid for each bid item shown on the Bid Item List or as changed by change order with a specified price adjustment

Full compensation for work specified in the Contract Documents is included in the payment for the bid items involved unless:

1. Bid item for the work is shown on the Bid Item List
2. Work is specified as change order work

Work paid for under one bid item is not paid for under any other bid item. Payment for a bid item includes payment for all work associated with that bid item.

No payment adjustments for price index fluctuations will be allowed.

The Department pays for change order work based on one or a combination of the following:

1. Bid item prices
2. Force account
3. Agreed price
4. Specialist billing

If the Engineer chooses to pay for change order work based on an agreed price, but you and the Engineer cannot agree on the price, the Department pays by force account. If a portion of extra work is covered by bid items, the Department pays for this work as changed quantities in those items. The Department pays for the remaining portion of the extra work by force account or agreed price.

Pay your subcontractors within 7 days of receipt of each progress payment unless otherwise agreed to in writing under Business and Professions Code Section 7108.5.

Changed Quantity Payment Adjustments

If the total bid item quantity exceeds 125 percent of the quantity shown on the Bid Item List and if no approved Change Order addresses payment for the quantity exceeding 125 percent, the Engineer may adjust the unit price for the excess quantity under force account or the following:

1. The adjustment is the difference between the unit price and the unit cost of the total item pay quantity.
2. In determining the unit cost, the Engineer excludes the item's fixed costs. You have recovered the fixed costs in the payment for 125 percent shown on the Bid Item List.
3. After excluding fixed costs, the Engineer determines the item unit cost under force account.

If the payment for the number of units of a bid item in excess of 125 percent of the Bid Item List is less than \$5,000 at the unit price, the Engineer may not adjust the unit price unless you request it.

If the total item pay quantity is less than 75 percent of the quantity shown on the Bid Item List and if no approved Change Order addresses payment for the quantity less than 75 percent, you may request a unit price adjustment. The Engineer may adjust the unit price for the decreased quantity under force account or the following:

1. The adjustment is the difference between the unit price and the unit cost of the total pay quantity.
2. In determining the unit cost, the Engineer includes the item's fixed costs.
3. After including fixed costs, the Engineer determines the item unit cost under force account.

The Department does not pay more than 75 percent of the item total in the Bid Item List.

Force Account

For work paid by force account, the Engineer compares the County's records to your daily force-account work report. When you and the Engineer agree on the contents of the daily force-account work reports, the Engineer accepts the report and the County pays for the work. If the records differ, the County pays for the work based only on the information shown on the Department's records.

If a subcontractor performs work at force account, accept an additional 10 percent markup to the total cost of that work paid at force account, including markups, as reimbursement for additional administrative costs. The markups specified for labor, materials, and equipment include compensation for all delay costs, overhead costs, and profit.

If an item's unit price is adjusted for work-character changes, the County excludes your cost of determining the adjustment.

Payment for owner-operated labor and equipment is made at the market-priced invoice submitted.

Progress Payments

The County pays you based on Engineer-prepared monthly progress estimates. Each estimate reflects:

1. Total work completed during the pay period
2. Change order bills if:
 - 2.1. Submitted by the 15th day of a month
 - 2.2. Approved by the 20th day of a month
3. Amount for materials on hand
4. Amount earned for mobilization
5. Deductions
6. Withholds
7. Resolved potential claims
8. Payment adjustments

Submit certification stating the work complies with the QC procedures. The Engineer does not process a progress estimate without a signed certification.

Final Payment

After Contract acceptance, the Department pays you based on the Engineer-prepared estimate that includes withholds and the balance due after the deduction of previous payments.

The Engineer estimates the amount of work completed and shows the amount payable in a proposed final estimate based on:

1. Contract items
2. Payment adjustments
3. Work paid by force account or agreed price
4. Extra work
5. Deductions

Submit either a written acceptance of the proposed final estimate or a claim statement postmarked or hand delivered before the 31st day after receiving the proposed final estimate. If you claim that the proposed final estimate is less than 90 percent of your total bid, the Department adjusts the final payment to cover your overhead. The adjustment is 10 percent of the difference between the total bid and the final estimate. The Department does not make this adjustment on a terminated contract. If you accept the proposed final estimate or do not submit a claim statement within 30 days of receiving the estimate, the Engineer provides you the final estimate and the Department pays the amount due within 30 days.

If you submit a claim statement within 30 days of receiving the Engineer's proposed final estimate, the Engineer provides you a semifinal estimate and the Department pays the amount due within 30 days. The semifinal estimate is conclusive as to the amount of work completed and the amount payable except as affected by any claims.

Payment Withholds

The County may withhold payment for noncompliance.

The County returns the noncompliance withhold in the progress payment following the correction of noncompliance except as specified below. Withholds are not retentions under Public Contract Code Section 7107 and do not accrue interest under Public Contract Code Section 20104.50(b). Withholds are cumulative and independent of deductions. This section does not include all withholds that may be taken; the Department may withhold other payments as specified.

The County withholds 10 percent of a progress payment for noncompliant progress. Noncompliant progress occurs when:

1. Total days to date exceed 75 percent of the contract time
2. Percent of the contract time elapsed exceeds the percent of value of the work completed by more than 15 percent

The Engineer determines the percent of the contract time elapsed by dividing the total days to date by the amount of days remaining and converting the quotient to a percentage.

The Engineer determines the percent value of the work completed by summing payments made to date and the amount due on the current progress estimate, dividing this sum by the current total estimated value of the work, and converting the quotient to a percentage. These amounts are shown on the Pay Estimate.

When the percent of the contract time elapsed minus the percent value of work completed is less than or equal to 15 percent, the County returns the withhold in the next progress payment.

During each estimate period you fail to comply with a Contract part, including the submittal of a document as specified, the County withholds a part of the progress payment except as specified below for the failure to submit a document during the last estimate period. The documents include QC plans, required forms, schedules, traffic control plans, water pollution control submittals, and dust control submittals. If you fail to comply with water pollution control or dust control requirements, the Department withholds part of the progress payment.

For 1 performance failure, the County withholds 25 percent of the progress payment but does not withhold more than 10 percent of the total bid.

For multiple performance failures, the County withholds 100 percent of the progress payment but does not withhold more than 10 percent of the total bid.

During the last estimate period, if you fail to submit a document as specified, the County withholds \$10,000 for each document. The Department returns the withhold within 30 days after receipt of the document.

The Department may withhold payments to cover claims filed under Civil Code Section 9000, et seq. Stop notice information may be obtained from the Engineer.

Penalties include fines and damages that are proposed, assessed, or levied against you or the County by a governmental agency or private lawsuit. Penalties are also payments made or costs incurred in settling alleged violations of federal, State, or local laws, regulations, requirements, or PLACs. The cost incurred may include the amount spent for mitigation or correcting a violation.

If the County is assessed a penalty, the County may withhold the penalty amount until the penalty disposition has been resolved. The County may withhold penalty amounts without notifying you.

Instead of the withhold, you may provide a bond equal to the highest estimated liability for any disputed penalties proposed except you may not provide a bond for withholds related to labor compliance violations.

Retentions

The Department will retain 5% of the value of each progress payment (excluding mobilization payments) from each progress payment. After the Engineer determines that the Project is substantially complete, the Department may, at the Engineer's sole discretion, release half of all retention previously withheld and reduce any subsequent retentions withheld from subsequent progress payments to 2.5% of the value of any subsequent progress payments (excluding mobilization payments). The retained funds will be returned within thirty-five (35) days after recordation of the Notice of Acceptance.

You may elect to receive one hundred percent (100%) of payments due under the Contract from time to time, without retention of any portion of the payment by the County, by depositing securities of equivalent value with the County (Public Contract Code Section 22300). Securities eligible for deposit hereunder are limited to those listed in Section 16430 of the Government Code, or bank or savings and loan certificates of deposit.

Funds retained from progress payments to ensure performance of the Contract that are eligible for payment into escrow or to an escrow agent pursuant to Section 22300 of the Public Contract Code do not include funds withheld or deducted from payment due to your failure to fulfill a contract requirement.

You or your subcontractor must return all monies withheld in retention from subcontractors within 30 days after receiving payment of retainage. Violation of this section subjects you to the penalties, sanctions, and other remedies of Business and Professions Code Section 7108.5. This section must not be construed to limit or impair any contractual, administrative, or judicial remedies otherwise available to you in the event of a dispute involving late payment or nonpayment by you, deficient subcontract performance, or noncompliance by a subcontractor.

Measurement

The Department determines bid item quantities under US customary units. Except for final pay item quantities, the Engineer measures quantities for payment. Measure material quantities for payment with devices that comply with:

1. 4 CA Code of Regulations Section 4000, et seq.
2. Business and Professions Code Section 12001, et seq.

The County shows a bid item quantity as a final pay item for payment purposes only. For a final pay item, accept payment based on the Bid Item List quantity, regardless of the actual quantity used unless dimensions are changed by the Engineer.

The Engineer determines the weights of aggregate and other roadway material that are being paid for by weight as shown in the following table and does not include the deducted weight of water in their payment quantities:

Material	Quantity Determination
Aggregate or other roadway material except as otherwise shown in this table	By deducting the weight of water in the material ^a in excess of 3 percent of the dry weight of the material from the weight of the material
Imported borrow, imported topsoil, AB	By deducting the weight of water in the material ^a in excess of 6 percent of the dry weight of the material from the weight of the material
Straw	By deducting the weight of water in the material ^a in excess of 15 percent of the dry weight of the material from the weight of the material

Fiber ^b	Engineer does not deduct the weight of water
AB and aggregate for CTBs	By Volume: determined from dimensions shown By Weight: by deducting the weight of water at the time of weighing in excess of the optimum moisture content (CA Test 216) plus 1 percent from the weight of the aggregate base.
NOTE: Percentage of water is determined by California Test 226. ^a At the time of weighing ^b Weight of water in the fiber ^a must not exceed 15 percent of the dry weight of the fiber.	

The County may make a payment adjustment for an excusable delay that affects your costs. Only losses for idle equipment, idle workers, and moving or transporting equipment are eligible for delay related payment adjustments. The Engineer determines payment for idle time of equipment in the same manner as determinations are made for equipment used in the performance of force account work with the following exceptions:

1. Delay factor in the Labor Surcharge and Equipment Rental Rates applies to each equipment rental rate.
2. Daily number of payable hours equals the normal working hours during the delay, not to exceed 8 hours per day.
3. Delay days exclude non-working days.
4. Markups are not added.

The Engineer determines payment adjustment for the idle workers as force account, but does not add markups. The Engineer includes costs due to necessary extra moving or transporting of equipment. The Department does not make a payment adjustment for overhead incurred during non-working days of additional construction seasons experienced because of delay.

8. Performance Bond

As a part of the execution of this Agreement, Contractor shall furnish a bond of a surety company authorized to do business in the State of California, conditioned upon the faithful performance of all covenants and stipulations under this Agreement. The amount of this bond shall be one hundred percent (100%) of the total Contract Price and shall be executed upon the form provided by County.

9. Payment Bond

As a part of the execution of this Agreement, Contractor shall furnish a bond of a surety company authorized to do business in the State of California, conditioned upon the payment in full of all claims for labor and materials in accordance with the provisions of the law of the State of California. The amount of this bond shall be one hundred percent (100%) of the total Contract Price and shall be executed upon the form provided by County.

10. Notification of Surety Company

The surety company shall familiarize itself with all of the conditions and provisions of this Agreement, and shall waive the right of special notification of any change or modifications of this Agreement or extension of time, or of decreased or increased work, or of the cancellation of the Agreement, or of any other act or acts by County or its authorized agents, under the terms of this Agreement; and failure to so notify the aforesaid surety company of changes shall in no way relieve the surety company of its obligation under this Agreement.

11. Assignment of Antitrust Actions

In entering into a public works Contract or a Subcontract to supply goods, services, or materials pursuant to a public works Contract, the Contractor offers and agrees and will require all of its subcontractors and suppliers to agree to assign to the awarding body all rights, title, and interest in and to all causes of action it may have under Section 4 of the Clayton Act (15 U.S.C. Sec. 15) or under the Cartwright Act (Chapter 2 (commencing with Section 16700)

of Part 2 of Division 7 of the Business and Professions Code), arising from purchases of goods, services, or materials pursuant to the public works Contract or the subcontract. This assignment shall be made and become effective at the time the awarding body tenders final payment to Contractor, without further acknowledgment by the parties.

If an awarding body or public purchasing body receives, either through judgment or settlement, a monetary recovery for a cause of action assigned under Government Code Sections 4550-4554, the assignor shall be entitled to receive reimbursement for actual legal costs incurred and may, upon demand, recover from the public body any portion of the recovery, including treble damages, attributable to overcharges that were paid by the assignor but were not paid by the public body as part of the bid price, less the expenses incurred in obtaining that portion of the recovery. Upon demand in writing by the assignor, the assignee shall, within one year from such demand, reassign the cause of action assigned under Government Code Sections 4550-4554 if the assignor has been or may have been injured by the violation of law for which the cause of action arose and (a) the assignee has not been injured thereby, or (b) the assignee declines to file a court action for the cause of action.

12. Payment of Prevailing Wages

Contractor shall pay and require payment of wages according to a scale of prevailing wage rates determined by California law, which scale is on file at County's Community Development Agency, Transportation Division's principal office and shall comply with all applicable wage requirements, as set forth in Labor Code Sections 1770 et seq., 1773.2, 1775, 1776, 1810, and 1813. In accordance with the provisions of Labor Code Section 1810, eight (8) hours of labor shall constitute a legal day's work upon all Work done hereunder, and Contractor and any subcontractor employed under this Contract shall also conform to and be bound by the provisions of Labor Code Sections 1810 through 1815. Interested parties can obtain the current wage information by submitting their requests to the Department of Industrial Relations, Division of Labor Statistics and Research, PO Box 420603, San Francisco CA 94142-0603, Telephone (415) 703-4708 or by referring to the website at <http://www.dir.ca.gov/OPRL/PWD>. The rates at the time of the bid advertisement date of a project will remain in effect for the life of the project in accordance with the California Code of Regulations, as modified and effective January 27, 1997.

13. Apprentices

Attention is directed to Sections 1777.5, 1777.6 and 1777.7 of the California Labor Code and 8 California Code of Regulations Section 200, et seq. To ensure compliance and complete understanding of the law regarding apprentices, and specifically the required ratio thereunder, each Contractor or subcontractor should, where some question exists, contact the Division of Apprenticeship Standards, 455 Golden Gate Avenue, San Francisco, CA 94102, or one of its branch offices prior to commencement of work on the public works contract. Responsibility for compliance with this section lies with Contractor.

It is County policy to encourage the employment and training of apprentices on public works contracts as may be permitted under local apprenticeship standards.

14. Certified Payroll

As required under the provisions of Labor Code Section 1776, Contractor and any subcontractors shall keep accurate payroll records as follows:

1. The payroll records shall show the name, address, social security number, work classification, straight time and overtime hours worked each day and week, and the actual per diem wages paid to each journeyman, apprentice, worker, or other employee employed by Contractor or subcontractors in connection with this Project.

2. A certified copy of all payroll records enumerated above shall be available for inspection at all reasonable hours at the principal office of Contractor as follows:

-
- a. Make available or furnish to the employee or his or her authorized representative on request.
 - b. Make available for inspection or furnished upon request to a representative of County, the State Division of Labor Standards Enforcement, and the Division of Apprenticeship Standards of the State Department of Industrial Relations.
 - c. Make available upon request by the public for inspection or copies thereof made; provided, however, that a request by the public shall be made through either County, the State Division of Labor Standards Enforcement, or the State Division of Apprenticeship Standards. The requesting party shall, prior to being provided the records, reimburse the costs of preparation by Contractor, subcontractor, and the entity through which the request was made. The public shall not be given access to the records at the principal office of Contractor.
 - d. All contractors and subcontractors must furnish electronic certified payroll records directly to the Department of Industrial Relations.

15. Registration of Contractors

No contractor or subcontractor may bid on any public works project, be listed in a bid proposal for any public works project or engage in the performance of any contract for public work unless registered with the Department of Industrial Relations pursuant to Labor Code Sections 1725.5 and 1771.1.

Contractor shall post job site notices as prescribed by 8 of California Code of Regulations Section 16451.

16. Records Examination and Audit Requirements

Contractor and its subcontractors, if any are authorized hereunder, shall maintain all books, documents, papers, accounting records, and other evidence pertaining to the performance of the Agreement, including but not limited to, the costs of administering the various aspects of the Agreement. In accordance with Government Code Section 8546.7, all of the above-referenced parties shall make such materials available at their respective offices at all reasonable times during the contract period and for four (4) years from the date that final payment by County and all other pending matters are closed. Representatives of County, the State Auditor, and any duly authorized representative of other government agencies shall have access to any books, documents, papers, and records that are pertinent to the Agreement for audit, examination, excerpts, and transactions and copies thereof shall be furnished upon request.

17. Payment of all Federal, State, or Local Taxes

Any federal, state, or local tax payable on the articles furnished by Contractor under the Agreement shall be included in the Contract Price and paid by Contractor.

18. Compliance with all Applicable Laws

Contractor shall conform to and abide by all Federal, State, and local building, labor and safety laws, ordinances, rules and regulations. All Work and materials shall be in full accordance with the latest rules and regulations of the State Fire Marshal, safety orders of the Division of Industrial Safety, California Electrical Code, California Building Code, California Plumbing Code, and any and all other applicable laws and regulations. Nothing in the Contract Documents, including but not limited to the plans and specifications, is to be construed to permit work not conforming to these codes, laws, and regulations.

19. Nondiscrimination

- A. County may require Contractor’s services on projects involving funding from various state and/or federal agencies, and as a consequence, Contractor shall comply with all applicable nondiscrimination statutes and regulations during the performance of this Agreement including but not limited to the following: Contractor and its employees and representatives shall not unlawfully discriminate against any employee or applicant for employment because of race, religion, color, national origin, ancestry, physical disability, mental disability, medical condition, marital status, age, genetic information, gender, gender identity, gender expression, sexual orientation, or military or veteran status; Contractor shall, unless exempt, comply with the applicable provisions of the Fair Employment and Housing Act (Government Code Sections 12900, et seq.) and applicable regulations promulgated thereunder (2 California Code of Regulations Section 11000, et seq.); the applicable regulations of the Fair Employment and Housing Commission implementing Government Code Section 12990, set forth in Subchapter 5 of Chapter 5 of Division 4.1 of Title 2 of the California Code of Regulations incorporated into this Agreement by reference and made a part hereof as if set forth in full; and Title VI of the Civil Rights Act of 1964, as amended. Contractor and its employees and representatives shall give written notice of their obligations under this clause as required by law.
- B. Where applicable, Contractor shall include these nondiscrimination and compliance provisions in any of its agreements that affect or are related to the services performed herein.
- C. Contractor’s signature shall provide any certifications necessary under the federal laws, the laws of the State of California, including but not limited to Government Code Section 12990 and 2 California Code of Regulations Section 11002.

20. Reporting Accidents

Contractor shall prepare and submit (within 24 hours of such incidents) reports of accidents at the site and anywhere else the work is in progress in which bodily injury is sustained or property loss in excess of Five Hundred Dollars (\$500.00) occurs.

21. Workers’ Compensation

Contractor shall comply with Labor Code Section 3700, et seq., requiring it to obtain Workers’ Compensation Insurance, and sign a certificate of knowledge thereof.

CERTIFICATE OF KNOWLEDGE - LABOR CODE SECTION 3700

I am aware of the provisions of Section 3700 of the Labor Code which require every employer to be insured against liability for workers’ compensation or to undertake self-insurance in accordance with the provisions of that Code, and I will comply with such provisions before commencing the performance of the work of this Agreement.

Signed: _____ Date: _____

22. Emissions Reduction

Contractor shall comply with emission reduction regulations mandated by the California Air Resources Board, and sign a certification of knowledge thereof:

CERTIFICATE OF KNOWLEDGE – EMISSIONS REDUCTION REGULATIONS

I am aware of the emissions reduction regulations being mandated by the California Air Resources Board. I will comply with such regulations before commencing the performance of the Work, maintain compliance throughout the duration of this Contract, and provide County a Certificate of Reported Compliance.

Signed: _____ Date: _____

23. Deviation from Plans and Specifications

No deviation shall be made from the Contract Documents, if any, without the prior written approval of Contract Administrator.

24. Unity of Plans and Specifications

The plans and specifications, if any, are one document, and any work shown or mentioned, in one and not in the other, or vice versa, shall be furnished or performed as though mentioned or shown in both.

25. Utilities

At least 48 hours before beginning any Work involving trenching or digging, Contractor shall notify Underground Service Alert (USA) at 811 or at 800-642-2444 with the specifics of the intended Work on the job site. Contractor shall follow and comply with all USA policies and procedures. Contractor shall obtain a USA ticket number and wait for USA to mark the location of underground utilities in conflict with the Project, or for USA to advise Contractor of the absence of underground utilities in the Project area.

As required by Section 4215 of the Government Code, County will assume responsibility for the removal, relocation, and protection of main or trunk-line utility facilities existing on the Work site, if such facilities are not shown in the Contract Documents, and County shall compensate Contractor for the costs of locating and repairing damage to such facilities not due to the failure of Contractor to exercise reasonable care.

Nothing herein shall be deemed to require County to indicate the presence of existing service laterals or appurtenances whenever the presence of such utilities on the site of the Project can be inferred from the presence of other visible facilities, such as buildings, meter and junction boxes, on or adjacent to the site of the Work.

If Contractor, while performing the Work under the Contract, discovers utility facilities not identified in the Contract Documents, including the plans or specifications, Contractor shall immediately notify County's Contract Administrator or Project Manager. County shall not be liable for Contractor's performance of unauthorized Work.

26. Pre-Construction Conference

At the Maintenance Division Office, 2441 Headington Road, Placerville attend a pre-construction conference with key personnel, including all major superintendents for the Work and major subcontractors. The pre-construction conference will be scheduled after the project is awarded and prior to the issuance of the Notice to Proceed. At this conference, submit in writing, signed by the officers of the corporation, if applicable, the names of two employees who will be the superintendents on the project. The second name serves as an alternate in the absence of the first designee. The superintendent must be on the site at all times that Work is in progress.

27. Notice of Discovery of Hazardous Waste or Unusual Conditions

- A. Contractor shall promptly, and before the following conditions are disturbed, notify County in writing, in the event Contractor encounters, after excavating to a depth of greater than four (4) feet, any of the following:
1. Material that Contractor believes may be hazardous waste, as defined in section 25117 of the Health and Safety Code, which is required to be removed to a Class I, Class II, or Class III disposal site in accordance with provisions of existing law;
 2. Subsurface or latent physical conditions at the site differing materially from those indicated in the Contract Documents; or
 3. Unknown physical conditions at the site of any unusual nature, differing materially from those ordinarily encountered and generally recognized as inherent in the Work provided for in the Agreement.
- B. County shall promptly investigate the conditions, and if it finds that the conditions do materially so differ, involve hazardous waste, or cause a decrease or increase in Contractor's cost of or time required for performance of any part of the Work, an adjustment, excluding loss of anticipated profits, will be made and the Contract Documents will be modified by a Change Order. County will notify Contractor of County's determination as to whether or not an adjustment of the Contract Documents is warranted.
- C. In the event a dispute arises between County and Contractor as to whether the conditions materially differ, or involve hazardous waste, or cause a decrease or increase in Contractor's cost of or time required for performance of any part of the Work, Contractor shall not be excused from any scheduled completion date provided for by the Agreement, but shall proceed with all Work to be performed under the Agreement. Contractor shall retain any and all rights provided either by contract or by law which pertain to the resolution of disputes and protests between Contractor and County.

28. Subcontracting

The provisions of Sections 4100-4114, inclusive, of the Public Contract Code regarding sub-contracting shall apply to this Contract, and Contractor represents that it will comply with all provisions therein.

The Subcontractor List in the Proposal must show the name, contractor's license number, DIR number and address and Work portions in excess of 0.5% or \$10,000, whichever is greater, to be performed by each subcontractor listed. The Work portion to be performed must be shown by listing the bid item number, bid item description, and portion of the Work to be performed by the subcontractor in the form of a percentage (not to exceed 100%) calculated by dividing the Work to be performed by the subcontractor by the respective bid item amount(s) (not by the total bid price). **The completed Subcontractor Listing Form in the Proposal must be submitted at time of bid.**

An inadvertent error in listing the California Contractor license number on the Subcontractor List will not be grounds for filing a bid protest or grounds for considering the bid non-responsive if the Bidder submits the corrected contractor's license number to Jen Rimoldi via fax (530) 626-0387 or email Jennifer.rimoldi@edcgov.us within 24 hours after the bid opening, provided the corrected contractor's license number corresponds to the submitted name and location for that subcontractor.

29. Additional Work

County reserves the right to make such alterations, deviations, or additions to or deletions from the plans and specifications, including the right to increase or decrease the quantity of any item or portion of work or to delete any items or portion of work, as may be deemed by the Contract Administrator or Project Manager to be necessary

or advisable, and to require such additional work to be required for the proper completion of the whole Work contemplated.

Any such changes will be set forth in a Contract Change Order (Change Order) which will specify the additional work, adjustment of performance time, if any, and basis for additional or reduced compensation, if any. Any Change Order shall not become effective until approved by the Director of Transportation, or where required, by the Board of Supervisors.

30. Termination by County for Convenience

County reserves the right to terminate the Agreement at any time, in whole or in part, for convenience upon thirty (30) calendar days written Notice of Termination. County shall issue Contractor a written notice specifying that the Agreement is to be terminated.

Upon receipt of said written notice, Contractor shall stop all work under the Agreement except: (1) work specifically directed to be completed prior to termination, (2) work the Inspector deems necessary to secure the Project for termination, (3) removal of equipment and plant from the site of the Work, (4) action that is necessary to protect materials from damage, (5) disposal of materials not yet used in the Work as directed by County, and (6) clean-up of the site.

If the Agreement is terminated for County's convenience as provided herein, all finished or unfinished work and materials previously paid for shall, at the option of County, become its property. Contractor shall be paid an amount which reflects costs incurred for work provided to the date of notification of termination. In addition, Contractor shall be paid the reasonable cost, as solely judged by County, and without profit, for all work performed to secure the Project for termination.

31. Termination by County for Cause

County may, without prejudice to any other right or remedy and after giving Contractor a minimum of ten (10) days from delivery of a written termination notice, terminate the services of Contractor if any of the following events occur:

1. Contractor is adjudged as bankrupt or insolvent.
2. Contractor makes a general assignment for the benefit of its creditors or if a trustee or receiver is appointed for Contractor or for any of its property.
3. Contractor files a petition to take advantage of any debtor's act, or to reorganize under the bankruptcy or applicable laws.
4. Contractor on more than one occasion fails to supply sufficient skilled workmen or suitable material or equipment.
5. Contractor on more than one occasion fails to make prompt payments to subcontractors for labor, materials, or equipment.
6. Contractor disregards the authority of County's representative, or the Engineer, if one is appointed.
7. Contractor violates Article 41.
8. Contractor otherwise violates any material provision of the Contract Documents.

County shall state in that written notice the reason(s) for the default. After that ten (10) day period has elapsed, County may terminate the services of Contractor immediately and take equipment and machinery thereon owned by Contractor and finish the Work by whatever method County may deem expedient. In such case, Contractor shall not be entitled to receive any further payment until the Work is finished.

Without prejudice to other rights or remedies County may have, County may serve Contractor with an Inspector's written notice demanding satisfactory compliance with this Agreement if Contractor does any of the following:

1. Fails to begin delivery of materials and equipment, to commence Work within the time specified, or to maintain the rate of delivery of material.

-
2. Fails to execute the Work in the manner and at such locations as specified.
 3. Fails to maintain a work program which will ensure County's interest.
 4. Contractor is not carrying out the intent of this Agreement.

If Contractor does not comply with such notice within five (5) days after receiving it, or after starting to comply, fails to continue, County may exclude it from the premises and take possession of all material and equipment, and complete the Work by County's own forces, by letting the unfinished Work to another Contractor, or by a combination of such methods.

Where Contractor's services have been so terminated by County, said termination shall not affect any right of County against Contractor then existing or which may thereafter accrue. Any retention or payment of monies by County due Contractor will not release Contractor from compliance with the Contract Documents.

If the unpaid balance of the Contract Price exceeds the direct and indirect costs of completing the Work, including compensation for additional professional services, such excess shall be paid to Contractor. If the sums under the Agreement are insufficient for completion, Contractor shall pay to County within five (5) days after the completion, all costs in excess of the Contract Price. In any event, the cost of completing the Work shall be charged against Contractor and may be deducted from any money due or becoming due from County.

The provisions of this Article shall be in addition to all other rights and remedies available to County under law.

If after notice of termination, it is determined for any reason that Contractor was not in default, the rights and obligations of the parties shall be the same as if the notice of termination had not been issued. The Agreement shall be equitably adjusted to compensate for such termination.

32. Successors and Assigns

This Agreement shall bind and inure to the heirs, devisees, assignees, and successors in interest of Contractor and to the successors in interest of County in the same manner as if such parties had been expressly named herein.

33. Assignment of Contract

Neither this Agreement, nor any part thereof, or any monies due or to become due hereunder, may be assigned by Contractor without the written approval of County, nor without the consent of the Surety unless the Surety has waived its right to notice of assignment in writing. County may assign this Agreement to a lender, or any third party that assumes the obligations of County hereunder.

34. Amendments

This Agreement may be amended by mutual consent of the parties hereto. Said amendment shall become effective only when in writing and fully executed by duly authorized officers of the parties hereto.

35. Separate Contracts

County reserves the right to let other contracts in connection with the Work. Contractor shall afford all other such contractors reasonable opportunity for storage of their materials, shall provide that the execution of its work properly connects and coordinates with theirs, and shall cooperate with them to the end of facilitating the Work.

36. Indemnity

To the fullest extent allowed by law, Contractor shall defend, indemnify, and hold County, its (their) officers, directors, and employees, and the State of California (State), its officers, directors, agents (excluding agents who are design professionals), and any Federal government agencies associated with this Contract harmless against and

from any and all claims, suits, losses, damages, and liability for damages, including attorney's fees and other costs of defense brought for or on account of injuries to or death of any person, including but not limited to, workers and the public, or on account of injuries to or death of County, State, or Federal government agency employees, or damage to property, or any economic, consequential or special damages which are claimed or which shall in any way arise out of or be connected with Contractor's services, operations or performance hereunder, regardless of the existence or degree of fault or negligence on the part of the County, the State of California, or any Federal government agencies, the Contractor, subcontractors or employees of any of these, except for the active, or sole negligence of the County, the State of California or any Federal government agencies their officers and employees, or where expressly prescribed by statute.

The duty to indemnify and hold harmless the County, the State, and any Federal government agencies associated with this Contract specifically includes the duties to defend set forth in Section 2778 of the Civil Code. The insurance obligations of Contractor are separate, independent obligations under the Contract Documents, and the provisions of this defense and indemnity are not intended to modify nor should they be construed as modifying or in any way limiting the insurance obligations set forth in the Contract Documents.

Nothing herein shall be construed to seek indemnity in excess of that permitted by Civil Code Section 2782, et seq. In the event any portion of this Article is found invalid, the Parties agree that this Article shall survive and be interpreted consistent with the provisions of Civil Code Section 2782, et seq.

This indemnification will remain in effect until terminated or modified in writing by mutual agreement.

37. Insurance

GENERAL INSURANCE REQUIREMENTS: Contractor shall provide proof of a policy of insurance satisfactory to County's Risk Management Division and documentation evidencing that Contractor maintains insurance that meets the following requirements:

1. Full Workers' Compensation and Employers' Liability Insurance covering all employees of Contractor as required by law in the State of California.
2. Commercial General Liability Insurance (providing scope of coverage equivalent to ISO policy form CG 00 01) of not less than Two Million Dollars (\$2,000,000) combined single limit per occurrence for bodily injury and property damage, including but not limited to endorsements for the following coverage: premises, personal injury, operations, products and completed operations, blanket contractual, and independent contractors' liability and a \$4,000,000 aggregate limit. County, including, without limitation, its officers, officials, employees, and volunteers shall be named as an additional insured on ISO form CG 2010 1185, or its equivalent.
3. Automobile Liability Insurance of not less than One Million Dollars (\$1,000,000) is required in the event motor vehicles are used by Contractor in performance of the Contract.
4. In the event Contractor is a licensed professional and is performing professional services under this Agreement, Professional Liability Insurance is required with a limit of liability of not less than One Million Dollars (\$1,000,000).
5. Explosion, Collapse and Underground coverage is required when the scope of work includes XCU exposures. For purposes of this Contract, XCU coverage is not required.

PROOF OF INSURANCE REQUIREMENTS:

1. Contractor shall furnish proof of coverage satisfactory to County's Risk Management Division as evidence that the insurance required herein is being maintained. The insurance will be issued by an insurance

company acceptable to County's Risk Management Division, or be provided through partial or total self-insurance likewise acceptable to the Risk Management Division.

2. The County of El Dorado, its officers, officials, employees, and volunteers shall be included as additional insured, but only insofar as the operations under this Agreement are concerned. This provision shall apply to all general and excess liability insurance policies. Proof that County is named additional insured shall be made by providing the Risk Management Division with a certified copy, or other acceptable evidence, of an endorsement to Contractor's insurance policy naming County as additional insured.
3. In the event Contractor cannot provide an occurrence policy, Contractor shall provide insurance covering claims made as a result of performance of this Agreement for not less than three (3) years following completion of performance of this Agreement.
4. Any deductibles or self-insured retentions must be declared to and approved by County. At the option of County, either: the insurer shall reduce or eliminate such deductibles or self-insured retentions as respects County, its officers, officials, employees, and volunteers; or Contractor shall procure a bond guaranteeing payment of losses and related investigations, claim administration, and defense expenses.
5. Contractor shall require each of its subcontractors to procure and maintain Commercial General Liability Insurance, Automobile Liability Insurance, and Workers' Compensation Insurance of the types and in the amounts specified above, or shall insure the activities of its subcontractors in its own policy in like amounts. Contractor shall also require each of its subcontractors to name Contractor and the County of El Dorado as additional insureds on each subcontractor's general and excess liability insurance policies. Upon request by County Contractor shall furnish proof of coverage satisfactory to County as evidence that the subcontractor insurance required herein is being maintained.

INSURANCE NOTIFICATION REQUIREMENTS:

1. Contractor agrees that no cancellation or material change in any policy shall become effective except upon prior written notice to Community Development Agency, Contract Services Unit, 2850 Fairlane Court, Placerville, California 95667.
2. Contractor agrees that the insurance required herein shall be in effect at all times during the term of this Agreement, inclusive of the guarantee/warranty period specified herein below. In the event said insurance coverage expires at any time or times during the term of this Agreement, Contractor shall immediately provide a new certificate of insurance as evidence of the required insurance coverage. In the event Contractor fails to keep in effect at all times insurance coverage as herein provided, County may, in addition to any other remedies it may have, terminate this Agreement upon the occurrence of such event. New certificates of insurance are subject to the approval of County's Risk Management Division.

ADDITIONAL STANDARDS: Certificates shall meet such additional standards as may be determined by County's Department of Transportation either independently or in consultation with County's Risk Management Division, as essential for protection of County.

COMMENCEMENT OF PERFORMANCE: Contractor shall not commence performance of this Agreement unless and until compliance with each and every requirement of the insurance provisions is achieved.

MATERIAL BREACH: Failure of Contractor to maintain the insurance required herein, or to comply with any of the requirements of the insurance provisions, shall constitute a material breach of the entire Agreement.

REPORTING PROVISIONS: Any failure to comply with the reporting provisions of the policies shall not affect the coverage provided to County, its officers, officials, employees or volunteers.

PRIMARY COVERAGE: Contractor's insurance coverage shall be primary insurance as respects County, its officers, officials, employees and volunteers. Any insurance or self-insurance maintained by County, its officers, officials, employees, or volunteers shall be in excess of Contractor's insurance and shall not contribute with it.

PREMIUM PAYMENTS: The insurance companies shall have no recourse against County, its officers, agents, employees, or volunteers, or any of them for payment of any premiums or assessments under any policy issued by any insurance company.

CONTRACTOR'S OBLIGATIONS: Contractor's indemnity and other obligations shall not be limited by the insurance required herein and shall survive the expiration of this Agreement.

38. Independent Contractor

It is understood that the services provided under this Agreement shall be prepared in and with cooperation from County and its staff. It is further understood that this Agreement does not create an exclusive relationship between County and Contractor, and Contractor may perform similar work or services for others. However, Contractor shall not enter into any agreement with any other party, or provide any information in any manner to any other party, that would conflict with Contractor's responsibilities or hinder Contractor's performance of services hereunder, unless County's Contract Administrator, in writing, authorizes that agreement or sharing of information.

The parties intend that an independent contractor relationship will be created by this contract. Contractor is, and shall be at all times, deemed independent and shall be wholly responsible for the manner in which it performs services required by the terms of this Agreement. Contractor exclusively assumes responsibility for acts of its employees, agents, affiliates, and subcontractors, if any are authorized herein, as they relate to the services or work to be performed under this Agreement during the course and scope of their employment by Contractor. Those persons will be entirely and exclusively under the direction, supervision, and control of Contractor.

County may designate the tasks to be performed and the results to be accomplished under this Agreement, provide information concerning the work or services, approve or disapprove the final work product and/or services provided, and set deadlines for the completion of the work or services, but County will not control or direct the manner, means, methods, or sequence in which Contractor performs the work or services for accomplishing the results. Contractor understands and agrees that Contractor lacks the authority to bind County or incur any obligations on behalf of County.

Contractor, including any subcontractor or employees of Contractor, shall not receive, nor be eligible for, any benefits County provides for its employees, including, but not limited to, vacation pay, paid holidays, life insurance, health insurance, social security, disability insurance, pension, or 457 plans. Contractor shall not receive, nor be eligible for, workers' compensation, including medical and indemnity payments. County is not responsible for withholding, and shall not withhold, Federal Income Contribution Act amounts or taxes of any kind from any payments which it owes Contractor. Contractor shall not be subject to the work schedules or vacation periods that apply to County employees.

Contractor shall be solely responsible for paying its employees, and for withholding Federal Income Contribution Act amounts and other taxes, workers' compensation, unemployment compensation, medical insurance, life insurance, or any other benefit that Contractor provides for its employees.

Contractor acknowledges that it has no authority to bind the County or incur any obligations on behalf of the County with regard to any matter, and shall not make any agreements or representations on the County's behalf.

39. Force Majeure

Neither party will be liable for any delay, failure to perform, or omission under this Agreement that is due to any cause that it is beyond its control, not due to its own negligence, and cannot be overcome by the exercise of due diligence. In that event, the affected party will:

1. Promptly give written notice to the other of the fact that it is unable to so perform and the cause(s) that is beyond its control.
2. Once the cause(s) has ceased, provide written notice to the other party and immediately resume its performance under this Agreement.

For purposes of this Article, “cause that is beyond its control” includes labor disturbances, riots, fires, earthquakes, floods, storms, lightning, epidemics, war, disorders, hostilities, expropriation or confiscation of properties, failure of and delays by carriers, interference by civil or military authorities, whether legal or de facto, and whether purporting to act under some constitution, decree, or law, or otherwise, or acts of God.

40. Waiver

No failure on the part of the parties to exercise any rights under this Agreement, and no course of dealing with respect to any right hereunder, shall operate as a waiver of that right, nor shall any single or partial exercise of any right preclude the exercise of any other right. The remedies herein provided are cumulative and are not exclusive of any other remedies provided by law.

41. Conflict of Interest

The parties to this Agreement have read and are aware of the provisions of Government Code Section 1090, et seq. and the Political Reform Act of 1974 (Section 87100 et seq.), relating to conflict of interest of public officers and employees. Individuals who are working for Contractor and performing work for County and who are considered to be consultant within the meaning of 2 California Code of Regulations Section 18700.3, as it now reads or may thereafter be amended, are required to file a statement of economic interest in accordance with County’s Conflict of Interest Code. County’s Contract Administrator shall at the time this Agreement is executed make an initial determination whether or not the individuals who will provide services or perform work pursuant to this Agreement are consultants within the meaning of the Political Reform Act and County’s Conflict of Interest Code. Statements of economic interests are public records subject to disclosure under the California Public Records Act.

Contractor covenants that during the term of this Agreement neither it, or any officer or employee of the Contractor, has or shall acquire any interest, directly or indirectly, in any of the following:

1. Any other contract connected with, or directly affected by, the services to be performed by this Agreement.
2. Any other entities connected with, or directly affected by, the services to be performed by this Agreement.
3. Any officer or employee of County that are involved in this Agreement.

If Contractor becomes aware of a conflict of interest related to this Agreement, Contractor shall promptly notify County of the existence of that conflict, and County may, in its sole discretion, immediately terminate this Agreement by giving written notice of termination specified in Article 31.

42. Licenses

Contractor warrants and represents that it holds a valid California license pursuant to the Contractors’ State License Law (Business and Professions Code Section 7000, et seq.), that its license is in good standing and that it possesses a Class A – General Contractor License as required by the categories and type of the Work. Copies of Contractor’s State Contractors’ license must be provided with this Agreement.

43. Business License

County's Business License Ordinance provides that it is unlawful for any person to furnish supplies or services or transact any kind of business in the unincorporated territory of County of El Dorado without possessing a County business license unless exempt under County Ordinance Code Section 5.08.070. Contractor warrants and represents that it shall comply with all of the requirements of County's Business License Ordinance, where applicable, prior to beginning work under this Agreement and at all times during the term of this Agreement.

44. Cleaning Up

Contractor shall not allow the site of the Work to become littered with trash, rubbish, or waste material, and shall maintain the site of Work in a neat and orderly condition throughout the performance of the Work. At the end of each work day, Contractor shall clean up all debris and waste materials generated by the Work and shall properly dispose of all trash, rubbish, and waste materials off site at no additional cost to County.

45. Access to the Work

County, and any state or local authorities having jurisdiction over the Project, shall at all times have access to the Work. Contractor shall maintain at least one lane of traffic at all times unless prior authorization is given by County. Roads cannot be closed without prior approval by County.

46. Acceptance of Work

The Work will be accepted by County in writing when the whole is completed satisfactorily, as determined by County or its duly authorized representative. Acceptance of the Work shall not constitute an acceptance of latent defects nor relieve Contractor of responsibility for any act or omission which is a violation of the Contract.

47. Resolution of Claims

As permitted by Public Contract Code Section 20104, the County has elected to resolve any claims between you and the County pursuant to Article 7.1 (commencing with Section 10240) of Chapter 1 of Part 2 of the Public Contract Code. This Article describes the contract claim procedure. The provisions of this Article constitute a non-judicial claim settlement procedure, and also step one of a two-step claim presentment procedure by agreement under Section 930.2 of the Government Code. Specifically, step one is compliance with the contract claim procedure in accordance with the Contract Documents, including Article 47. Step two is the filing of a timely Government Code Section 910 et seq. claim in accordance with the Government Code. Any such claim shall affirmatively indicate your prior compliance with the contract claim procedure and previous dispositions under this Article. Any claim that fails to conform to the contract claim procedure required in step one may not be asserted in any subsequent Government Code Section 910 et seq. claim.

As a condition precedent to arbitration or litigation, claims must first be mediated. Mediation is non-binding and the services of a mediator mutually acceptable to the parties must be used and, if the parties cannot agree, a mediator will be selected by the American Arbitration Association from its panel of approved mediators trained in construction industry mediation. All statutes of limitations shall be tolled from the date of the demand for mediation until a date two weeks following the mediation's conclusion. The cost of mediation shall be equally shared by the parties.

Your attention is directed to Public Contract Code Section 9204, which describes procedures for the resolution of claims on public works projects. Among other things, Section 9204 requires the claimant to furnish reasonable documentation to support a claim, requires the public entity to respond to the claim within 45 days of receipt of the claim, and allows for the claimant to demand an informal meet and confer conference for settlement of the issues in dispute. For any portion of a claim that remains in dispute, section 9204 requires submission of the claim to nonbinding mediation. Additionally, Section 9204 requires the public entity to make any payment due on an

undisputed portion of the claim within 60 days of the public entity's written response and to pay interest at the rate of 7 percent per annum on any amounts not paid in a timely manner. The claims procedures described within the Contract Documents (including, but not limited to, this article) are in addition to the procedures required by Section 9204 and, in the event of a conflict between those various procedures, the more stringent procedures will control.

The County's costs in reviewing or auditing a claim not supported by the Contractor's accounting or other records are damages incurred by the County within the meaning of the California False Claims Act.

If the Engineer determines that a claim requires additional analysis, the Engineer schedules a review board meeting. Meet with the board of review and make a presentation supporting the claim. After the Engineer or review board finishes reviewing the claim, the County makes the final determination of claims and provides it to you. The Engineer provides you a final estimate and the Department pays the amount due within 30 days. The final estimate is conclusive as to the amount of work completed and the amount payable. Your failure to comply with the claim procedures is a bar to arbitration under Public Contract Code Section 10240.2

If you fail to comply with these claim procedures as to any claim, then you waive your rights to this claim. County must not be deemed to waive or alter any provision of this Article if, at County's sole discretion, County administers a claim in a manner not in accord with those provisions.

Minimize and mitigate the impacts of work or events for which you will make a potential claim.

Claim Procedure

For each potential claim, assign an identification number determined by chronological sequencing and the 1st date of the potential claim.

Submit a declaration that includes the following language with each claim statement:

I declare under penalty of perjury, according to the laws of the State of California, that the foregoing claims, with specific reference to the California False Claims Act (Government Code Section 12650, et seq.) and to the extent the project contains federal funding, the US False Claims Act (31 USC § 3729 et seq.), are true and correct, and that this declaration was signed on _____ (date) _____, 20__ at _____, California.

Use the identification number for each potential claim on the:

1. Initial Potential Claim Record form
2. Supplemental Potential Claim Record form
3. Full and Final Potential Claim Record form

Failure to comply with this procedure is:

1. Waiver of the potential claim and a waiver of the right to a corresponding claim for the disputed work in the administrative claim procedure
2. Bar to arbitration (Public Contract Code Section 10240.2)

Submit an Initial Potential Claim Record form within 5 business days of the Engineer's response to the Request for Information (RFI) or within 5 business days from the date when a dispute arises due to an act or failure to act by the Engineer. The Initial Potential Claim Record form establishes the claim's nature and circumstances. The nature and circumstances must remain consistent.

The Engineer responds within 5 business days of receiving the form. Proceed with the work for which you will make a potential claim unless otherwise ordered.

Within 20 days of a request, provide access to the project records determined necessary by the Engineer to evaluate the potential claim.

Within 15 days of submitting the Initial Potential Claim Record form, submit a Supplemental Potential Claim Record form including:

1. Complete nature and circumstances causing the potential claim
2. Contract specifications supporting the basis of a claim
3. Estimated claim cost and an itemized breakdown of the individual costs stating how the estimate was determined
4. TIA

The Engineer evaluates the Supplemental Potential Claim Record form and responds within 20 days of receiving the submittal. To pursue a potential claim, comply with this Article.

If the estimated cost or effect on the scheduled completion date changes, update the Supplemental Potential Claim Record form information as soon as the change is recognized and submit this information.

Notify the Engineer within 10 days of the completion date of the potentially claimed work. The Engineer authorizes this completion date or notifies you of a revised date.

Within 30 days of the completion of the potentially claimed work, submit a Full and Final Potential Claim Record form including:

1. Detailed factual account of the events causing the potential claim, including:
 - 1.1. Pertinent dates
 - 1.2. Locations
 - 1.3. Work items affected by the potential claim
2. Contract documents supporting the potential claim and a statement of the reasons these parts support entitlement
3. Itemized cost breakdown if a payment adjustment is requested. Segregate costs into the following categories:
 - 3.1. Labor, including:
 - 3.1.1. Individuals
 - 3.1.2. Classifications
 - 3.1.3. Regular and overtime hours worked
 - 3.1.4. Dates worked
 - 3.2. Materials, including:
 - 3.2.1. Invoices
 - 3.2.2. Purchase orders
 - 3.2.3. Location of materials either stored or incorporated into the work
 - 3.2.4. Dates materials were transported to the job site or incorporated into the work
 - 3.3. Equipment, including:
 - 3.3.1. Detailed descriptions, including make, model, and serial number
 - 3.3.2. Hours of use
 - 3.3.3. Dates of use
 - 3.3.4. Equipment rates at the rental rate listed in Labor Surcharge and Equipment Rental Rates in effect when the affected work related to the claim was performed
4. Detailed account of the time impact if a time adjustment is requested:
 - 4.1. Dates for the requested time.
 - 4.2. Reasons for a time adjustment.
 - 4.3. Contract documentation supporting the requested time adjustment.

-
- 4.4. TIA. The TIA must demonstrate entitlement to a time adjustment.
 5. Identification and copies of your documents and copies of communications supporting the potential claim, including certified payrolls, bills, canceled checks, job cost reports, payment records, and rental agreements
 6. Relevant information, references, and arguments that support the potential claim

The Department does not consider a Full and Final Potential Claim Record form that does not have the same nature, circumstances, and basis of claim as those specified on the Initial Potential Claim Record form and Supplemental Potential Claim Record form.

The Engineer evaluates the information presented in the Full and Final Potential Claim Record form and responds within 30 days of its receipt unless the Full and Final Potential Claim Record form is submitted after Contract acceptance, in which case, a response may not be provided. The Engineer's receipt of the Full and Final Potential Claim Record form must be evidenced by postal return receipt or the Engineer's written receipt if delivered by hand.

A claim is waived if:

1. Claim does not have a corresponding Full and Final Potential Claim Record form identification number
2. Claim does not have the same nature, circumstances, and basis of the claim as the corresponding Full and Final Potential Claim Record form
3. Claim is not included in the claim statement
4. You do not comply with the claim procedures
5. You do not submit the declaration stated above
6. Failure to allow timely access to the supporting data for a claim when requested

48. Environmental and Toxic Warranty

Contractor warrants that its operations concerning the Project are not and will not be in violation of any applicable federal, state, or local environmental statute, law, or regulation dealing with hazardous materials substances or toxic substances.

49. Guarantee

Final Guarantee: Contractor shall guarantee all materials and equipment furnished and work performed for a period of one (1) year. Contractor warrants and guarantees for a period of one (1) year from the date of Acceptance of the Work that the Work is free from all defects due to faulty materials or workmanship and Contractor shall promptly make such corrections as may be necessary, including repairs of any damage to other parts of the Work resulting from such defects. County will give notice of observed defects with reasonable promptness. In the event that Contractor should fail to make such repairs, adjustments, or other work that may be made necessary by such defects, County may do so and charge Contractor the cost thereby incurred.

Extended Guarantees: If a guaranty exceeding one (1) year is provided by the supplier or manufacturer of any equipment or materials used in this Project, then the guarantee for such equipment or materials shall be extended for such term. Contractor expressly agrees to act as co-guarantor of such equipment and materials, and Contractor shall supply County with all warranty and guaranty documents relative to equipment and materials incorporated in the job and guaranteed by its suppliers or manufacturers.

Warranty: Contractor warrants to County that materials and equipment furnished under the Contract will be of good quality and new, unless otherwise required or permitted by the Contract, that the Work will be free from defects or flaws and is of the highest quality of workmanship and that the Work will conform with the requirements

of the Contract. Work not conforming to these requirements, including substitutions not properly approved and authorized, shall be considered defective.

If within one (1) year from the date of the Acceptance of the Work or such longer period of time as may be prescribed by law or regulations or by the terms of any applicable special guarantee required by the contract documents, any work is found to be defective, Contractor shall promptly, without cost to County and in accordance with County's written instruction, correct such defective work. If work is rejected by County, defective material or work will be removed from site and replaced with non-defective materials or work. If Contractor is unable to promptly and properly correct any defective work, County may at its option have the work corrected by such other means as County deems appropriate and hold Contractor liable for all direct, indirect and consequential costs caused by such defective work. Said warranty shall apply to all work found to be "defective" which is attributable to the quality or quantity of the materials used, the quality of the workmanship or for performance of the Contract.

50. Notice

Any notice or other correspondence required to be given under this Agreement by either party to the other may be affected by personal delivery in writing or by mail, postage prepaid. Notices personally delivered during normal business hours shall be deemed received on the actual date of delivery; mailed notices shall be deemed received one (1) day after affixed postmark. Notices and correspondence to County shall be in duplicate and shall be delivered to it as follows:

To County:

County of El Dorado
Department of Transportation
2441 Headington Road
Placerville, California 95667

Attn.: Brian Mullens, Deputy Director
Maintenance and Operations Division

With a Copy To:

County of El Dorado
Chief Administrative Office
330 Fair Lane
Placerville, California 95667

Attn.: Michele Weimer
Purchasing Agent
Contracts and Procurement Unit

Notices and correspondence to Contractor shall be delivered when personally delivered to, or if mailed, addressed to Contractor at:

Contractor Name
Street Address
City, State Zip Code

Either party may change its address for notices or for its principal place of business by giving written notice pursuant to this Article.

51. Change of Address

In the event of a change in address for Contractor's principal place of business, Contractor's Agent for Service of Process, or Notices to Contractor, Contractor shall notify County in writing as provided in Article 47, Notice. Said notice shall become part of this Agreement upon acknowledgment in writing by County's Contract Administrator, and no further amendment of the Agreement shall be necessary provided that such change of address does not conflict with any other provisions of this Agreement.

52. Drug-Free Workplace

Contractor shall comply with Government Code Section 8355.

53. California Residency (Form 590)

All independent Contractors providing services to County must file a State of California Form 590, certifying their California residency or, in the case of a corporation, certifying that they have a permanent place of business in California. Contractor will be required to submit a Form 590. This requirement applies to any Agreement/Contract exceeding \$1,500.00.

54. Nonresident Withholding

If Contractor is not a California resident, Contractor shall provide documentation that the State of California has granted a withholding exemption or authorized reduced withholding prior to execution of this Agreement or County shall withhold seven (7%) percent of each payment made to the Contractor during term of the Agreement as required by law. This requirement applies to any agreement/contract exceeding \$1,500.00. Contractor shall indemnify and hold County harmless for any action taken by the California Franchise Tax Board.

55. County Payee Data Record Form

All independent contractors or corporations providing services to County must file a County Payee Data Record Form with County.

56. Taxes

Contractor certifies that as of today's date, it is not in default on any unsecured property taxes or other taxes or fees owed by Consultant to County. Contractor agrees that it shall not default on any obligations to County during the term of this Agreement.

57. Venue

The Contract Documents and all provisions thereto shall be governed by the laws of the State of California. Any litigation arising herein shall be brought in the County of El Dorado.

58. Contract Administrator

The County Officer or employee with responsibility for administering this Agreement is Brian Mullens, Deputy Director, Department of Transportation, Maintenance and Operations Division or successor.

59. Authorized Signatures

The parties to this Agreement warrant and represent that the undersigned individuals executing this Agreement on their respective behalves are fully authorized to do so by law or other appropriate instrument and to bind upon said parties the obligations set forth herein.

60. Partial Invalidity

If any provision, part of a provision, sentence, or word of this Agreement is held by a court of competent jurisdiction to be invalid, void or unenforceable, the remaining provisions, parts of provisions, sentences, and words will continue in full force and effect without being impaired or invalidated in any way.

61. No Third Party Beneficiaries

Nothing in this Agreement is intended, nor will be deemed, to confer rights or remedies upon any person or legal entity not a party to this Agreement.

62. Counterparts

This Agreement may be executed in one or more counterparts, each of which shall be an original and all of which together shall constitute one and the same instrument.

63. Entire Agreement

This document and the documents referred to herein or exhibits hereto are the entire Agreement between the parties and they incorporate or supersede all prior written or oral agreements or understandings.

IN WITNESS WHEREOF, the parties hereto have executed this Agreement on the dates indicated below, the latest of which shall be deemed to be the effective date of this Agreement.

-- COUNTY OF EL DORADO --

By: _____

Dated: _____

Rafael Martinez, Director
Department of Transportation
"County"

-- CONTRACTOR --

Dated: _____

License No. _____

Federal Employee Identification Number _____

By: _____
President

By: _____
Corporate Secretary

NOTE: If Contractor is a corporation, the legal name of the corporation shall be set forth above together with the signature of the officer or officers authorized to sign Contracts on behalf of the corporation; if Contractor is a co-partnership, the true name of the firm shall be set forth above together with the signature of the partner or partners authorized to sign Contracts on behalf of the co-partnership; and if Contractor is an individual, his/her signature shall be placed above. Contractor executing this document on behalf of a corporation or partnership shall be prepared to demonstrate by resolution, article, or otherwise that it is appropriately authorized to act in these regards. For such corporation or partnership, such authority shall be demonstrated to the satisfaction of County. If signature is by an agent, other than officer of a corporation or a member of a partnership, an appropriate Power of Attorney shall be on file with the County prior to signing this document.

Mailing Address: _____

Business Address: _____

Email Address: _____

Phone: _____

Fax: _____

EXHIBIT A

**SLT FUEL TANK AND DISPENSER INSTALLATION AND REMOVAL OF EXISTING SYSTEM
CONTRACT NO. 10197**

CONTRACTOR'S BID AND BID PRICE SCHEDULE

BASE BID -

ITEM NO.		ITEM DESCRIPTION	UNIT OF MEASURE	ESTIMATED QUANTITY	UNIT PRICE (IN FIGURES)	ITEM TOTAL (IN FIGURES)
1	130100	JOB SITE MANAGEMENT / MOBILIZATION	LS	1		
2	898000	REMOVE ASPHALT CONCRETE PAVEMENT	LS	1		
3	52010	BAR REINFORCING STEEL	LF	5900		
4	510050	STRUCTURAL CONCRETE	CY	105		
5	280010	POPCORN SLURRY	CY	3		
6		SECONDARY CONTAINMENT SUMPS (DP-1123B)	EACH	2		
7		TRANSITION SUMP WITH MONITORING (PSTF-4630)	EACH	1		
8		PERMITTING COSTS	LS	1		
9	203100	SOIL TESTING	LS	1		
10	260203	2" AB	CY	50		
11	480600	SHORING	LS	1		
12	208006	2" EPOXY COATED BLACK STEEL PIPE	LF	120		
13	208598	2" DOUBLE WALL FIBERGLASS PIPE	LF	70		
14	208601	PIPE BOLLARD	EACH	8		
TOTAL FOR BASE BID						

**COUNTY OF EL DORADO
PAYMENT BOND
(Section 9550, Civil Code)**

Bond No. _____

WHEREAS, the County of El Dorado, a political subdivision of the State of California, hereafter referred to as "Obligee", has awarded to Contractor

_____ hereafter referred to as "Principal", a Contract for the Work described as follows:

**SLT FUEL TANK AND DISPENSER INSTALLATION AND REMOVAL OF EXISTING SYSTEM
CONTRACT NO. 10197**

WHEREAS, said Principal is required to furnish a bond in connection with said Contract, guaranteeing the faithful performance thereof:

NOW, THEREFORE, we the undersigned Principal and Surety are held and firmly bound unto the Obligees, in the sum of _____ Dollars,
(\$ _____) to be paid to the Obligees, for which payment we bind ourselves, jointly and severally.

THE CONDITION OF THIS OBLIGATION IS SUCH,

That if said Principal or its Subcontractors shall fail to pay any of the persons named in Civil Code Section 9100, or amounts due under the Unemployment Insurance Code with respect to Work or labor performed by such claimant, or any amounts required to be deducted, withheld, and paid over to the Franchise Tax Board from the wages of employees of the Principal and his Subcontractors pursuant to Section 18806 of the Revenue and Taxation Code, with respect to such Work and labor, that the Surety herein will pay for the same in an amount not exceeding the sum specified in this bond, otherwise the above obligation shall be void. In case suit is brought upon this bond, the Surety will pay a reasonable attorney's fee to be fixed by the court.

This bond shall inure to the benefit of any of the persons named in Civil Code Section 9100 as to give a right of action to such persons or their assigns in any suit brought upon this bond.

Dated: _____

Correspondence or Claims relating to this bond should be sent to the Surety at the following address:

PRINCIPAL

SURETY

ATTORNEY-IN-FACT

NOTE: Signatures of those executing for the Principal and for the Surety must be properly acknowledged, and a Power of Attorney attached for the Surety.

NOTARY ACKNOWLEDGMENTS ATTACHED

PRINCIPAL

ACKNOWLEDGMENT

A notary public or other officer completing this certificate verifies only the identity of the individual who signed the document to which this certificate is attached, and not the truthfulness, accuracy, or validity of that document.

State of California
County of _____

On _____ before me, _____,
(here insert name and title of the officer)

personally appeared _____

who proved to me on the basis of satisfactory evidence to be the person(s) whose name(s) is/are subscribed to the within instrument and acknowledged to me that he/she/they executed the same in his/her/their authorized capacity(ies), and that by his/her/their signature(s) on the instrument the person(s), or the entity upon behalf of which the person(s) acted, executed the instrument.

I certify under PENALTY OF PERJURY under the laws of the State of California that the foregoing paragraph is true and correct.

WITNESS my hand and official seal.

Signature _____

(Seal)

SURETY

ACKNOWLEDGMENT

A notary public or other officer completing this certificate verifies only the identity of the individual who signed the document to which this certificate is attached, and not the truthfulness, accuracy, or validity of that document.

State of California
County of _____

On _____ before me, _____,
(here insert name and title of the officer)

personally appeared _____

who proved to me on the basis of satisfactory evidence to be the person(s) whose name(s) is/are subscribed to the within instrument and acknowledged to me that he/she/they executed the same in his/her/their authorized capacity(ies), and that by his/her/their signature(s) on the instrument the person(s), or the entity upon behalf of which the person(s) acted, executed the instrument.

I certify under PENALTY OF PERJURY under the laws of the State of California that the foregoing paragraph is true and correct.

WITNESS my hand and official seal.

Signature _____

(Seal)

**COUNTY OF EL DORADO
PERFORMANCE BOND**

Bond No. _____

KNOW ALL MEN BY THESE PRESENTS, that we _____

the Contractor in the Contract hereto annexed, as Principal, and _____
as Surety, are held firmly bound unto the County of El Dorado, a political subdivision of the State of California, hereinafter
called the "Obligee"

in the sum of _____ DOLLARS,

(\$ _____) lawful money of the United States, for which payment, well and truly to be made, we bind ourselves,
jointly and severally, firmly by these presents.

Signed, sealed and dated: _____

The condition of the above obligation is such that if said Principal as Contractor in the Contract hereto annexed shall faithfully perform each and all of the conditions of said Contract to be performed by him, and shall furnish all tools, equipment, apparatus, facilities, transportation, labor and material, other than material, if any, agreed to be furnished by the Obligees, necessary to perform and complete, and to perform and complete in a good and workmanlike manner, the Work of **Contract NO. 10197 for the SLT FUEL TANK AND DISPENSER INSTALLATION AND REMOVAL OF EXISTING SYSTEM** in strict conformity with the terms and conditions set forth in the Contract hereto annexed, then this obligation shall be null and void; otherwise this bond shall remain in full force and effect and the said Surety will complete the Contract Work under its own supervision, by Contract or otherwise, and pay all costs thereof for the balance due under terms of the Contract, and the said Surety, for value received, hereby stipulates and agrees that no change, extension of time, alteration or addition to the terms of the Contract or to the Work to be performed thereunder shall in any wise affect its obligation on this bond, and it does hereby waive notice of any such change, extension of time, alteration or addition to the terms of the Contract or to the Work.

In the event suit is brought upon this bond by the Obligee and judgment is recovered, the Surety shall pay all costs incurred by the Obligee in such suit, including a reasonable attorney's fee to be fixed by the court.

This guarantee shall insure the Obligee during the Work required by any Contract and for a period of one (1) year from the date of acceptance of the Work against faulty or improper materials or workmanship that may be discovered during that time.

No right of action shall accrue under this bond to or for the use of any person other than the Obligees named herein.

Dated: _____, 20____.

Correspondence or Claims relating to this bond should be sent to the Surety at the following address:

PRINCIPAL

SURETY

ATTORNEY-IN-FACT

NOTE: Signatures of those executing for the Principal and the Surety must be properly acknowledged, and a Power of Attorney attached for the Surety.

NOTARY ACKNOWLEDGMENTS ATTACHED

PRINCIPAL

ACKNOWLEDGMENT

A notary public or other officer completing this certificate verifies only the identity of the individual who signed the document to which this certificate is attached, and not the truthfulness, accuracy, or validity of that document.

State of California
County of _____

On _____ before me, _____,
(here insert name and title of the officer)

personally appeared _____

who proved to me on the basis of satisfactory evidence to be the person(s) whose name(s) is/are subscribed to the within instrument and acknowledged to me that he/she/they executed the same in his/her/their authorized capacity(ies), and that by his/her/their signature(s) on the instrument the person(s), or the entity upon behalf of which the person(s) acted, executed the instrument.

I certify under PENALTY OF PERJURY under the laws of the State of California that the foregoing paragraph is true and correct.

WITNESS my hand and official seal.

Signature _____

(Seal)

SURETY

ACKNOWLEDGMENT

A notary public or other officer completing this certificate verifies only the identity of the individual who signed the document to which this certificate is attached, and not the truthfulness, accuracy, or validity of that document.

State of California
County of _____

On _____ before me, _____,
(here insert name and title of the officer)

personally appeared _____

_____ ,

who proved to me on the basis of satisfactory evidence to be the person(s) whose name(s) is/are subscribed to the within instrument and acknowledged to me that he/she/they executed the same in his/her/their authorized capacity(ies), and that by his/her/their signature(s) on the instrument the person(s), or the entity upon behalf of which the person(s) acted, executed the instrument.

I certify under PENALTY OF PERJURY under the laws of the State of California that the foregoing paragraph is true and correct.

WITNESS my hand and official seal.

Signature _____

(Seal)

**EXHIBIT B
PROJECT SCOPE AND SPECIFICATIONS**

SCOPE OF WORK

The work, in general, includes the following:

- Contractor must provide all necessary construction services, including, but not limited to permitting, installation, testing and clean-up; and must furnish all necessary materials, equipment, supervision, labor, and services required to complete the project, as provided in the Contract Documents.
- Remove two (2) existing fuel dispensers and associated piping. Sawcut and remove concrete surrounding the existing fuel island, leaving the canopy pedestal intact. Remove existing hydronic heating system embedded in concrete slab. Grade and compact area if it does not meet compaction specifications.
- Installation of anchoring for two (2) existing UL-2085 Fireguard tanks with seismic hold-downs, two (2) turbine pumps (FE-STPAG150-VL3, 1.5 HP) on the top of the fuel tanks and install necessary emergency vents and corresponding fittings.
- Connect pumps to a common manifold feeding a single underground product line to two Bennett diesel dispensers. Install remote fill boxes for each tank on slab, install secondary containment sumps for dispensers (DP-1123B), valve stabilizer kits (SBK1100J), and transition sump with monitoring. Finally, install Morrison clock gauges on each tank.
- Install underground double-wall piping from manifold to dispensers per California Fire Code and National Fire Protection Associations 30A standard along with a transition sump with monitoring and include leak detection and monitoring per manufacturer and code requirements. Ensure depth and material to comply with state/local code and AHJ requirements.
- Run all conduit above ground along exterior wall of building south of island, connecting to main electrical panel located in the building directly south of the fuel island. Install emergency stop button on building exterior and provide power and controls for pumps, dispensers, FuelMaster system, and monitoring equipment.
- Install FuelMaster FMU-2500PLUSG keypad system and integrate TMS2000 Pneumercator base unit for leak detection. Connect sump sensors and alarms for containment monitoring.
- Replace hydronic heating system and construct concrete slab around existing center canopy pedestal to match existing infrastructure. When replacing hydronic heating system include insulation, tubing, glycol mix, and commissioning per local code. Installation of eight (8) 4" bollards around the canopy pedestal.
- Remove existing 20,000-gallon fiberglass double-wall UST (split 14K/6K). Perform soil sampling per Title 23 CCR and El Dorado County Environmental Management oversight. Backfill, compact, and pour 3,600 psi concrete to grade after closure approval.
- All work required to ensure permitting and compliance, including but not limited to, coordinating with County of El Dorado for building, electrical and mechanical permits, notifying El Dorado County CUPA for APSA and SPCC compliance.
- All work required to submit a Water Pollution Control Plan (WPCP), provide for temporary water pollution control.
- Fugitive Dust Plan, El Dorado County Air Quality Management District (AQMD) permit, and all work required to provide for dust control.

- All trenching, shoring, and trench plates to provide safe access at all times for the workers, public, and motorists. Protect freshly placed concrete until adequate strengths are achieved to and allow passage of traffic.
- All work required to remove existing 2,532 square feet of concrete and/or pavement and excavate 12" below original grade. Utilize #5 rebar at 16", 2" below deck to prevent cracking. Construct 12" concrete slab using 3,600 psi concrete mix.

PROJECT SPECIFICATIONS

1 - Control of Work

1.1 Definitions

Meeting: includes a meeting in which some or all of the participants are not physically present but take part by electronic communications such as telephone, closed-circuit television, Internet text, audio, or other audiovisual means.

Signature: includes an electronic or digital signature.

1.2 Summary

Occupy the roadway only for purposes necessary to perform the work.

You must coordinate your operations with the adjacent projects such that the requirements of this Contract are maintained.

2 - Start of Job Site Activities

2.1 Summary

Work will commence upon issuance in writing by the Engineer of Notice to Proceed. Project working hours are Monday – Friday between 7:00 am and 7:00 pm.

If coordination with a utility company is required after locating utilities, the Engineer will stop accrual of working days. A Contract change order will be written as needed to compensate you for cost incurred for additional trench plating time and/or additional costs associated.

The County may assess liquidated damages in accordance with Article 6 – Time of Completion of the Agreement.

3 - Temporary Traffic Controls

3.1 Summary

It is your responsibility to maintain a safe passage for County staff and any emergency responders through the Project site.

Perform all temporary traffic controls in accordance with the most current requirements of the Manual of Uniform Traffic Control Devices (MUTCD).

3.2 Payment

Payment for all costs associated with but not limited to installing, operating, and maintaining PCMS boards, temporary traffic controls, cones, signs, flaggers, the Traffic Control Plan, advance notification, etc. is provided for under the bid item for Traffic Control System.

4 - Temporary Water Pollution Controls - Storm Water Pollution Prevention Plan

4.1 Summary

Discharges of storm water from the project must comply with the requirements of the Tahoe Regional Planning Agency and the Lahontan Regional Water Quality Control Board.

Prepare water pollution control program includes developing, amending, and implementing the WPCP, providing a WPC Manager, conducting WPC training, and installing, monitoring, inspecting, reporting on, maintaining, and removing and disposing of WPC practices at the job site.

Submit your WPCP five (5) business days after the receipt of the Notice of Award letter.

4.2 Construction

You are required to furnish, install, maintain, and remove temporary water pollution controls to ensure debris, materials, and non-visible pollutants do not enter the existing storm drain systems, surface waters, or waters of the United States.

Throughout the entire construction period you will be responsible for ensuring that no material eroded from the work area leaves the job site via the conveyance system. You must provide adequate sediment barriers at storm drainpipe outlets, drainage inlets, and other collection points and provide adequate erosion control at channels and swales. A fine of \$100/day will be levied against you for each day you delay in responding to the County's request to install new temporary sediment control devices and/or maintain existing temporary sediment control devices.

The drainage inlet protection must be Type 2 or Type 3A, as appropriate for the conditions around the drainage inlet. Weighted fiber rolls are a suitable substitute for gravel filled bags. Gravel-filled bags must be repaired or replaced on the same day damage occurs. Damage to the gravel bag resulting from your vehicles, equipment, or activities will be repaired or replaced at your expense. Gravel-filled bags must be replaced if the bag material or roll material is ruptured or if the yarn has failed, allowing the gravel to spill out.

If you choose to place temporary fiber rolls, they must be temporary rice straw fiber rolls. They must be at least eight inches in diameter and be an Earth Savers wattle as manufactured by R.H. Dyck, Inc. or approved equal or Rice Straw Fiber Roll as manufactured by Kristar or approved equal. If an alternate product is proposed, submit product name, manufacturer, and description to Engineer for review and approval within 5 days of Notice of Award. Wood stakes for securing rice straw fiber rolls must be untreated fir, redwood, cedar, or pine, cut from sound timber, and must be straight and free of loose or unsound knots and other defects which would render them unfit for the purpose intended. Temporary rice straw fiber rolls must be repaired or replaced on the same day damage occurs. Damage to the temporary fiber rolls resulting from your vehicles, equipment, or activities will be repaired at your expense. If replacement of temporary rice straw fiber rolls is required due to your vehicles, equipment, or activities, replacement will be at your expense.

Weighted fiber rolls or alternatively, gravel-filled rolls may be used only in areas of compacted soil, concrete, or paved surfaces. Installation of the weighted fiber rolls or gravel-filled rolls will be per the manufacturer's recommendations.

The configuration for the use of weighted fiber rolls or gravel-filled rolls at drainage inlets is intended to filter sediment from runoff before the runoff enters inlets.

Weighted fiber rolls or gravel-filled rolls must be maintained to disperse concentrated water runoff and to reduce runoff velocities. Split, torn, or unraveling rolls must be repaired or replaced. Locations where rills and other evidence of concentrated runoff have occurred beneath the rolls must be corrected. Weighted fiber rolls or gravel-filled rolls must be repaired or replaced on the same day damage occurs. Damage to the temporary fiber rolls resulting from your vehicles, equipment, or activities will be repaired at your expense. If replacement of weighted fiber rolls or gravel-filled rolls is required due to your vehicles, equipment, or activities, replacement will be at your expense.

Weighted fiber rolls or, gravel-filled rolls must be a minimum length of 5 feet. Weighted fiber rolls must be eight inches in diameter and consist of a machined mat or blanket of shaved aspen wood curled excelsior

with a weighted inner core contained in a photodegradable, extruded, high visibility netting tube with a handle on each end. Eighty percent of the excelsior material must consist of fibers at least 6 inches in length. The fiber roll must be contained in a tubular orange-colored netting knotted at each end made from 85% high-density polyethylene and 14% ethyl vinyl acetate with titanium oxide for UV inhibition.

On-site storage of liquid waste containers will not be allowed.

Cleaning of vehicles or construction equipment will not be allowed within the Project.

Disposal of materials removed from the sweeper must comply with the dust control requirements elsewhere in these specifications.

Your operations may result in trackout of construction materials. You are responsible for tracking controls. Tracking control applies to streets within the Project as well as streets adjacent to the Project that have the potential to be impacted by tracking from the Work.

4.3 Payment

Payment for all costs associated with preparing and updating WPCP, furnishing, installing, maintaining, and removing temporary water pollution controls will be provided for under the bid item for Job Site Management.

Payment for Water Diversion Plan and implementation will be provided for under the bid item for Job Site Management.

5 - Dust Control

5.1 Summary

You must comply with Rules 223, 223-1, and 223-2 (Dust Rules) of the Rules and Regulations of the El Dorado County Air Quality Management District (AQMD). The Dust Rules can be obtained from AQMD at the following:

360 Fair Lane, Placerville, CA 95667

(530) 621-7501

www.edcgov.us/Government/AirQualityManagement

5.2 Submittals

Provide an acceptable plan for preventing the generation of dust due to your activities in construction zones, along haul or traveled routes, or in equipment parking zones. Your Dust Control Plan and daily dust control activities will not conflict with requirements of any agency having jurisdiction in the project area. You are required to have a water truck at the job site at all times during construction. Submit your Dust Control Plan as early as ten (10) working days after the receipt of the Notice of Award but no later than five (5) working days after Contract approval. Your Dust Control Plan must be approved by AQMD prior to the start of your work.

In the event the control of dust is not satisfactory to the Engineer, the Engineer will take measures as necessary to insure satisfactory salvage and will deduct the cost of those measures from payments due you. Dust control is a temporary erosion control measure or BMP. A fine of \$100/day will be levied against you for each day you delay in responding to the Engineer's request to implement this temporary erosion control measure.

5.3 Payment

The County does not pay for impacts to your productivity from mitigating dust from your activities.

Payment for all costs associated with developing a water supply, implementing dust control measures, AQMD permit application and Tahoe Regional Planning Agency permit application including preparing a fugitive dust plan, obtaining approval, and maintaining all dust control records as needed, will be provided for under the bid item for Job Site Management/Mobilization.

6 – Hot Mix Asphalt (HMA)

6.1 Summary

You will place 0.25-feet of compacted 1/2" aggregate HMA directly over trench slurry backfill material placed at least 12 hours prior to paving. Sawcut existing AC and remove one foot into existing base grade beyond the limits of the slurry backfill for a "T" section repave over the trench. This Project requires production and placement of HMA Type A under the Method construction process.

All HMA work shall be in accordance with the following general specifications for producing and placing HMA by aggregate and asphalt binder at a mixing plant and spreading and compacting the HMA mixture.

6.1.1 Definitions

binder replacement: Amount of RAP binder in OBC in percent.

coarse aggregate: Aggregate retained on a no. 4 sieve.

fine aggregate: Aggregate passing the no. 4 sieve.

processed RAP: RAP that has been fractionated.

substitution rate: Amount of RAP aggregate substituted for virgin aggregate in percent.

supplemental fine aggregate: Aggregate passing the no. 30 sieve, including hydrated lime, portland cement, and fines from dust collectors.

6.2 Materials

6.2.1 Tack Coat

Tack coat must comply with the specifications for asphaltic emulsion or asphalts.

You may choose the type and grade. You must submit the type and grade to the County for review and approval prior to use.

You may not dilute the asphaltic emulsion with water.

6.2.2 Asphalt Binder

Asphalt binder must comply with Caltrans' Certification Program for Suppliers of Asphalt. Program requirements, procedures, and a list of authorized material sources is online at the Caltrans Materials Engineering and Testing Services website: <http://www.dot.ca.gov/hq/esc/Translab>.

Asphalt binder used in HMA Type A must be PG 64-28 for all schedules.

It must comply with the requirements in the following table:

Quality Characteristic	Test Method	PG 64-28
Flash point (min, °C)	AASHTO T 48	230
Solubility ^b (min, %)	AASHTO T 44	99
Viscosity at 135 °C ^c (max, Pa·s)	AASHTO T 316	3.0
Dynamic shear Test temperature at 10 rad/s (°C) G*/sin(delta) (min, kPa) G*/sin(delta) (max, kPa)	AASHTO T 315	64 1.00 2.00
RTFO ^f test ^e mass loss (max, %)	AASHTO T 240	1.00
Dynamic shear Test temperature at 10 rad/s (°C) G*/sin(delta) (min, kPa)	AASHTO T 315	64 2.20
Ductility at 25 °C (min, cm)	AASHTO T 51	75
PAV ^g Test temperature (°C)	AASHTO R 28	100
Dynamic shear, Test temperature at 10 rad/s (°C) G*/sin(delta) (max, kPa)	AASHTO T 315	22 ^d 5000
Creep stiffness, Test temperature, °C S-value (max, MPa) M-value (min)	AASHTO T 313	-18 300 0.300

^aNot Applicable – ~~Use as asphalt rubber base stock for high mountain and high desert area.~~

^bThe Engineer waives solubility requirements if the supplier is an authorized material source as defined by the Department's *Certification Program for Suppliers of Asphalt*.

^cThe Engineer waives this specification if the supplier provides written certification the asphalt binder can be adequately pumped and mixed at temperatures meeting applicable safety standards.

^dTest the sample at 3 °C higher if it fails at the specified test temperature. G*/sin(delta) remains 5000 kPa maximum.

^eThe residue from mass change determination may be used for other tests.

^fRTFO means rolling thin film oven.

^gPAV means Pressure Aging Vessel.

6.2.3 Aggregate

Aggregate must be clean and free from deleterious substances.

The specified aggregate gradation must be determined before the addition of asphalt binder and includes supplemental fine aggregate.

Aggregate used in HMA Type A must comply with 1/2-inch HMA Type A gradation.

The proposed aggregate gradation must be within the TV limits for the specified sieve sizes shown in the following tables:

**Aggregate Gradation
(Percentage Passing)
HMA Type A**

1/2-inch HMA Type A		
Sieve sizes	TV limits	Allowable tolerance
3/4"	100	—
1/2"	95–99	TV ± 6
3/8"	75–95	TV ± 6
No. 4	55–66	TV ± 7
No. 8	38–49	TV ± 5
No. 30	15–27	TV ± 4
No. 200	2.0–8.0	TV ± 2

Before the addition of asphalt binder and lime treatment, aggregate must have the values for the quality characteristics shown in the following table:

Quality Characteristic	Test Method	HMA Type A
Percent of crushed particles Coarse aggregate (% min.) One fractured face	California Test 205	90
Two fractured faces		75
Fine aggregate (% min.) (Passing no. 4 sieve and retained on no. 8 sieve.) One fractured face	California Test 211	70
Los Angeles Rattler (% max.) Loss at 100 rev.		12
		45
Sand equivalent (min.) ^a	California Test 217	47
Fine aggregate angularity (% min.) ^b	California Test 234	45
Flat and elongated particles (% max. by weight @ 5:1)	California Test 235	10

a Reported value must be the average of 3 tests from a single sample.

b The Engineer waives this specification if HMA contains 10 percent or less of nonmanufactured sand by weight of total aggregate. Manufactured sand is fine aggregate produced by crushing rock or gravel.

6.3 HMA Mix Design Requirements

The mix design process consists of performing California Test 367 and laboratory procedures on combinations of aggregate gradations and asphalt binder contents to determine the OBC and HMA mixture qualities. The results become the proposed JMF.

Use the *Contractor Hot Mix Asphalt Design Data* form to record aggregate quality and mix design data. Use the *Contractor Job Mix Formula Proposal* form to present the JMF.

Laboratories testing aggregate qualities and preparing the mix design and JMF must be qualified under the Department's Independent Assurance Program. Take samples under California Test 125.

The Engineer reviews the aggregate qualities, mix design, and authorizes the JMF.

6.3.1 HMA Mix Design

Perform a mix design that produces HMA with the values for the quality characteristics shown in the following table:

Quality Characteristic	Test Method	HMA Type A
Air void content (%)	California Test 367	4.0
Voids in mineral aggregate (% min.) No. 4 grading 3/8" grading 1/2" grading 3/4" grading	California Test 367	17.0 15.0 14.0 13.0
Voids filled with asphalt (%) No. 4 grading 3/8" grading 1/2" grading 3/4" grading	California Test 367	65.0–75.0 65.0–75.0 65.0–75.0 65.0–75.0
Dust proportion No. 4 and 3/8" gradings 1/2" and 3/4" gradings	California Test 367	0.6–1.2 0.6–1.2
Stabilometer value (min.) No. 4 and 3/8" gradings 1/2" and 3/4" gradings	California Test 366	30 37

6.3.2 Job Mix Formula Submittal

Each JMF submittal must consist of:

1. Proposed JMF on a *Contractor Job Mix Formula Proposal* form
2. Mix design records on a *Contractor Hot Mix Asphalt Design Data* form dated within 24 months of submittal
3. JMF verification on a *Caltrans Hot Mix Asphalt Verification* form, if applicable
4. MSDS for the following:
 - 4.1. Asphalt binder
 - 4.2. Base asphalt binder used in asphalt rubber binder
 - 4.3. CRM and asphalt modifier used in asphalt rubber binder
 - 4.4. Blended asphalt rubber binder mixture
 - 4.5. Supplemental fine aggregate except fines from dust collectors
 - 4.6. Antistrip additives

If the Engineer requests, sample the following materials in the presence of the Engineer and place in labeled containers weighing no more than 50 lb each:

1. Coarse, fine, and supplemental fine aggregate from stockpiles, cold feed belts, or hot bins. Samples must be at least 120 lb for each coarse aggregate, 80 lb for each fine aggregate, and 10 lb for each type of supplemental fines. The Department combines these aggregate samples to comply with the JMF TVs submitted on a *Contractor Job Mix Formula Proposal* form.
2. RAP from stockpiles or RAP system. Samples must be at least 60 lb.
3. Asphalt binder from the binder supplier. Samples must be in two 1-quart cylindrical-shaped cans with open top and friction lids.
4. Asphalt rubber binder with the components blended in the proportions to be used. Samples must be in four 1-quart cylindrical-shaped cans with open top and friction lids.

Notify the Engineer at least 2 business days before sampling materials. For aggregate and RAP, split the samples into at least 4 parts. Submit 3 parts to the Engineer and use 1 part for your testing.

6.3.3 Job Mix Formula Review

The County reviews each mix design and proposed JMF within 5 business days from the complete JMF submittal. The review consists of reviewing the mix design procedures and comparing the proposed JMF with the specifications.

The County will not verify a JMF for this Contract.

6.3.4 Job Mix Formula Verification

Submit a pre-verified JMF on a *Caltrans Hot Mix Asphalt Verification* form dated within 24 months before HMA production.

Use the OBC specified on your *Contractor Hot Mix Asphalt Design Data* form. No adjustments to asphalt binder content are allowed. Based on your testing and production experience, you may submit an adjusted aggregate gradation TV on a *Contractor Job Mix Formula Proposal* form before verification testing. Aggregate gradation TV must be within the TV limits specified in the aggregate gradation tables.

Asphalt binder set point for HMA must be the OBC specified on your *Contractor Hot Mix Asphalt Design Data* form. When RAP is used, asphalt binder set point for HMA must be:

$$\text{Asphalt Binder Set Point} = \frac{\frac{BC_{OBC}}{\left(1 - \frac{BC_{OBC}}{100}\right)} - R_{RAP} \left[\frac{BC_{RAP}}{\left(1 - \frac{BC_{RAP}}{100}\right)} \right]}{100 + \frac{BC_{OBC}}{\left(1 - \frac{BC_{OBC}}{100}\right)}}$$

Where:

BC_{OBC} = optimum asphalt binder content, percent based on total weight of mix

R_{RAP} = RAP ratio by weight of aggregate

BC_{RAP} = asphalt binder content of RAP, percent based on total weight of RAP mix

6.3.5 Job Mix Formula Acceptance

You may start HMA production if:

1. The Engineer's review of the JMF shows compliance with the specifications.
2. The JMF has been within 24 months before HMA production.
3. The Engineer accepts the verified JMF.

6.4 Contractor Quality Control / Assurance

Subject to 7.7.2, County may collect and test HMA sample in the field to assure the materials are in compliance with the Contract.

6.5 Production

6.5.1 Production

Produce HMA in a batch mixing plant or a continuous mixing plant. Proportion aggregate by hot or cold feed control.

HMA plants must be pre-qualified by the Caltrans. Before production, the HMA plant must have current qualification under the Caltrans Materials Plant Quality Program.

During production, you may adjust hot or cold feed proportion controls for virgin aggregate and RAP.

During production, asphalt binder set point for HMA Type A must be the OBC shown in Contractor Hot Mix Asphalt Design Data form. For OGFC, asphalt binder set point must be the OBC shown on Caltrans Hot Mix Asphalt Verification form.

When RAP is used, asphalt binder set point for HMA must be:

$$\text{Asphalt Binder Set Point} = \frac{\frac{BC_{OBC}}{\left(1 - \frac{BC_{OBC}}{100}\right)} - R_{RAP} \left[\frac{BC_{RAP}}{\left(1 - \frac{BC_{RAP}}{100}\right)} \right]}{100 + \frac{BC_{OBC}}{\left(1 - \frac{BC_{OBC}}{100}\right)}}$$

Where:

BC_{OBC} = optimum asphalt binder content, percent based on total weight of mix

R_{RAP} = RAP ratio by weight of aggregate

BC_{RAP} = asphalt binder content of RAP, percent based on total weight of RAP mix

For RAP substitution rate of 25 percent or less, you may adjust the RAP by -5 percent.

You must request adjustments to the plant asphalt binder set point based on new RAP stockpiles average asphalt binder content. Do not adjust the HMA plant asphalt binder set point until authorized.

6.5.2 Mixing

Mix HMA ingredients into a homogeneous mixture of coated aggregates.

Asphalt binder must be from 275 to 375 degrees F when mixed with aggregate.

Asphalt rubber binder must be from 350 to 425 degrees F when mixed with aggregate.

When mixed with asphalt binder, aggregate must not be more than 325 degrees F, except aggregate for OGFC must be not more than 275 degrees F. These aggregate temperature specifications do not apply if you use RAP.

HMA with or without RAP must not be more than 325 degrees F.

6.6 Construction

Do not use petroleum products such as kerosene or diesel fuel to release HMA from trucks, spreaders, or compactors.

HMA must be free of:

1. Segregation
2. Coarse or fine aggregate pockets
3. Hardened lumps

6.6.1 Subgrade and Tack Coat

Prepare subgrade or apply tack coat to vertical joints adjacent to surfaces receiving HMA.

7.6.1.1 Subgrade

Subgrade to receive HMA must comply with the compaction and elevation tolerance specifications in the sections for the material involved. Subgrade must be free of loose and extraneous material. The HMA base grade may be the top of cement slurry backfill struck a continuous 0.25 feet below adjacent road grades. If HMA is paved on existing base or pavement, remove loose paving particles, dirt, and other extraneous material by any means including flushing and sweeping.

6.6.1.2 Tack Coat

Apply tack coat:

1. To existing pavement, including planed surfaces
2. Between HMA layers
3. To vertical surfaces of:

- 3.1. Curbs
- 3.2. Gutters
- 3.3. Construction joints

Before placing HMA, apply tack coat in 1 application. The application rate must be the minimum residual rate specified for the underlying surface conditions shown in the following tables:

Tack Coat Application Rates for HMA Type A

HMA overlay over:	Minimum residual rates (gal/sq yd)		
	CSS1/CSS1h, SS1/SS1h and QS1h/CQS1h asphaltic emulsion	CRS1/CRS2, RS1/RS2 and QS1/CQS1 asphaltic emulsion	Asphalt binder and PMRS2/PMCRS2 and PMRS2h/PMCRS2h asphaltic emulsion
New HMA (between layers)	0.02	0.03	0.02
PCC and existing HMA (AC) surfaces	0.03	0.04	0.03
Planed PCC and HMA (AC) surfaces	0.05	0.06	0.04

For vertical surfaces, apply a residual tack coat rate that will thoroughly coat the vertical face without running off.

If you request and if authorized, you may:

- 1. Change tack coat rates
- 2. Omit tack coat between layers of new HMA during the same work shift if:
 - 2.1. No dust, dirt, or extraneous material is present
 - 2.2. Surface is at least 140 degrees F

Immediately in advance of placing HMA, apply additional tack coat to damaged areas or where loose or extraneous material is removed.

Close areas receiving tack coat to traffic. Do not track tack coat onto pavement surfaces beyond the job site.

Asphalt binder tack coat must be from 285 to 350 degrees F when applied.

6.7 Transporting, Spreading, and Compacting

Pave HMA in a 0.25 foot thick compacted layer over the trench to at least one foot into existing base grade outside the limits of the cement slurry backfill. Compaction must be with a small ride-on smooth drum roller with a minimum 36" width.

If the surface to be paved is both in sunlight and shade, pavement surface temperatures must be taken in the shade.

Spread HMA Type A at the atmospheric and surface temperatures shown in the following table:

Minimum Atmospheric and Surface Temperatures

Compacted layer thickness, feet	Atmospheric, °F		Surface, °F	
	Unmodified asphalt binder	Modified asphalt binder ^a	Unmodified asphalt binder	Modified asphalt binder ^a
	< 0.15	55	50	60
0.15–0.25	45	45	50	50

^a Except asphalt rubber binder.

If the asphalt binder for HMA Type A and Type B is unmodified asphalt binder, complete:

1. First coverage of breakdown compaction before the surface temperature drops below 250 degrees F
2. Breakdown and intermediate compaction before the surface temperature drops below 200 degrees F
3. Finish compaction before the surface temperature drops below 150 degrees F

If the asphalt binder for HMA Type A and Type B is modified asphalt binder, complete:

1. First coverage of breakdown compaction before the surface temperature drops below 240 degrees F
2. Breakdown and intermediate compaction before the surface temperature drops below 180 degrees F
3. Finish compaction before the surface temperature drops below 140 degrees F

HMA compaction coverage is the number of passes needed to cover the paving width. A pass is 1 roller's movement parallel to the paving in either direction. Overlapping passes are part of the coverage being made and are not a subsequent coverage. Do not start a coverage until completing the prior coverage.

Start rolling at the lower edge and progress toward the highest part.

Perform breakdown compaction of each layer of HMA Type A with 3 coverages using a vibratory roller. The speed of the vibratory roller in miles per hour must not exceed the vibrations per minute divided by 1,000. If the thickness of the HMA layer is less than 0.08 foot, turn the vibrator off. The Engineer may order fewer coverages if the thickness of the HMA layer is less than 0.15 foot.

Perform intermediate compaction of each layer of HMA Type A with 3 coverages using a pneumatic-tired roller at a speed not exceeding 5 mph.

Perform finish compaction of HMA Type A with 1 coverage using a steel-tired roller.

6.7.1 Smoothness – Straightedge

The top layer of HMA pavement must not vary from the lower edge of a 12-foot straightedge:

1. More than 0.01 foot when the straightedge is laid parallel with the centerline
2. More than 0.02 foot when the straightedge is laid perpendicular to the centerline and extends from edge to edge of a traffic lane
3. More than 0.02 foot when the straightedge is laid within 24 feet of a pavement conform

6.7.2 Acceptance Criteria

The County samples materials for testing under California Test 125 and the applicable test method, except samples may be taken:

1. At the plant from a truck or an automatic sampling device
2. From the mat behind the paver

If you request, the Department splits samples and provides you with a part.
HMA acceptance is based on:

1. Authorized JMF
2. Compliance with the HMA acceptance (table below)
3. Visual inspection

6.8 Payment

Payment for the Hot Mix Asphalt (Type A, PG 64-28) (Trench) (Final Pay) bid item is final pay and adjustment will not be made for variation to the quantity shown in the Contractor's Bid and Bid Price Schedule.

8 –Concrete Pad

8.1 – Summary

Demolish and replace 2,532 square feet of concrete and/or pavement. Replace with a layer of geo-reinforcement grid approved by the Engineer, 0.50 foot thickness of compacted Class 2 AB, and 12" thickness of concrete reinforced with #5 rebar grid at 16" on center.

Without limiting the generality of the Contract requirements, Contractor must provide the following work services:

- a. Contractor will provide, install, and complete as specified and pay for all labor, materials and equipment, tools, supplies, construction equipment and machinery, construction, start-up and testing, utilities, transportation, and other facilities and services (including any temporary materials, utility relocation, equipment, supplies and facilities) necessary for the proper execution and completion of the Project.
- b. Contractor will supervise and direct the work performed by all its Subcontractors and Sub-consultants and will at all times be fully responsible and liable for the performance and completion of their work to the same extent as if directly performed by Contractor.
- c. Contractor will obtain all jurisdictional agency and private approvals, licenses, and permits required to complete the Work. Contractor will perform the Work in compliance with all applicable laws, codes and standards, both public and private, including but not limited to, the standards included, and warranties expressed in the Contract Documents and manufacturer's recommendations pertaining to individual items of equipment or systems.
- d. Contractor agrees to perform additional work on the project arising from changes ordered by the County pursuant to this Contract. Any additional work will be paid for via contract change order.

8.2 – Submittals

Concrete must be in compliance with CT Standard Specification 90-2. Submit concrete mix design prior to the start of any concrete work.

8.3 – Payment

Full compensation for the bid items for structural concrete includes all construction work including removal, disposal, installation, furnishing materials (grates, rebar, class 2 AB, geo reinforcement, etc.) for the associated bid items at the price shown on the Contractor's Bid and Bid Price Schedule.

ORIGINAL SCALE IS IN INCHES
 Drawing name: Z:\Civil 3D Projects\36302032 Shakori\Engineering\WPLAN\Shakori_UST_Layout.dwg Layout Tab: C-1 DETAIL Apr 17, 2026 - 3:11pm dgoodell
 FOR REDUCED PLANS

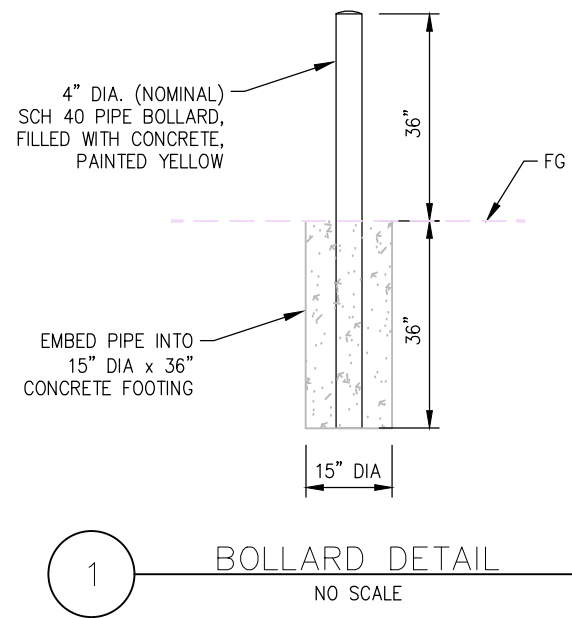

1 BOLLARD DETAIL
NO SCALE

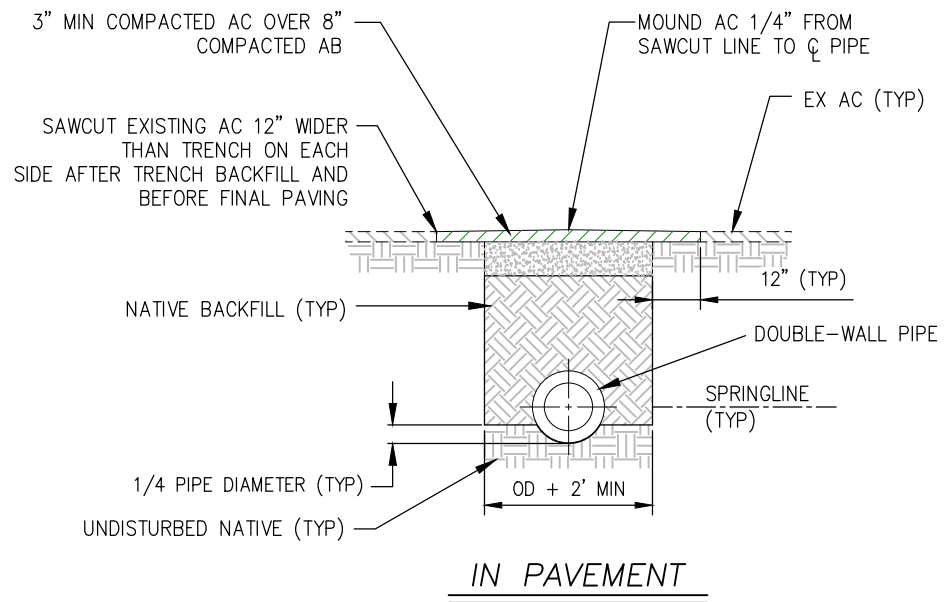

3 PIPE TRENCH
NO SCALE

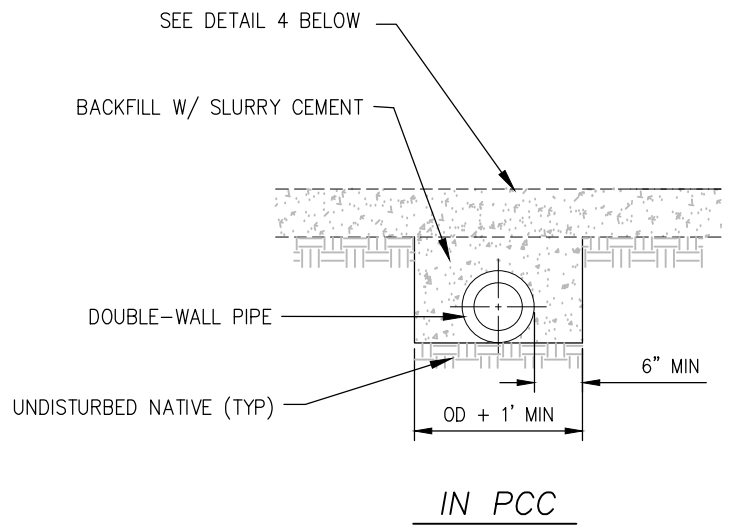

IN PCC

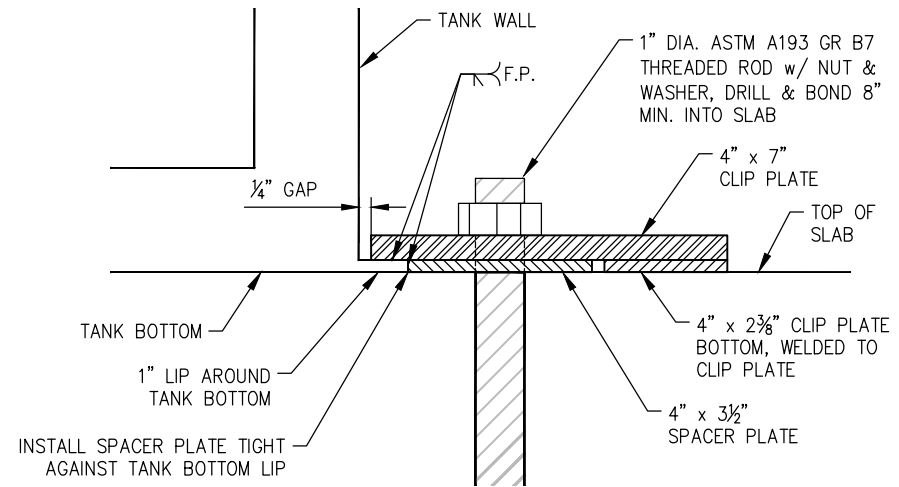

2 ANCHORAGE DETAIL
NO SCALE

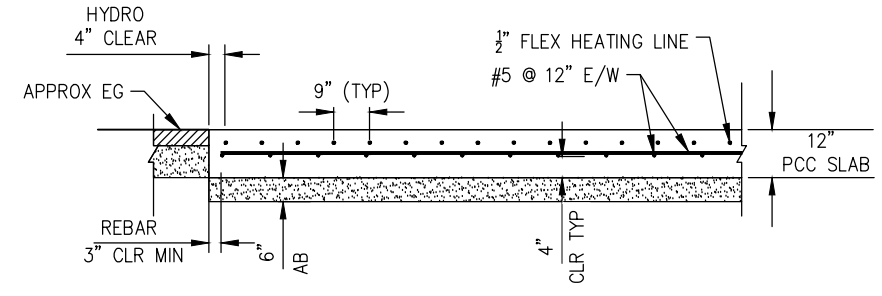

SECTION A-A

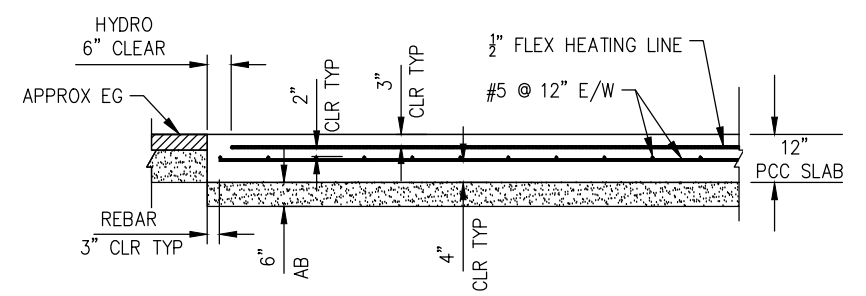

SECTION B-B

4 REINFORCED PCC PAD W/ HYDRONICS HEATING LINES
SCALE: 1" = 2'

CONSTRUCTION DETAILS
SCALE AS SHOWN

REVISION	NUMBER	DATE	DESCRIPTION	BY

PREPARED UNDER THE SUPERVISION OF :
 REGISTERED CIVIL ENGINEER
 DATE: _____

DESIGNED: DES DMG
 CHECKED: CHK
 DATE: 2/10/26
 ROAD NUMBER: ####



COUNTY OF EL DORADO
DEPARTMENT OF TRANSPORTATION

1121 SHAKORI DR, SOUTH LAKE TAHOE
FUEL TANK AND DISPENSER INSTALLATION
AND REMOVAL OF EXISTING SYSTEM

SHEET
C-1
3 OF 3
W.O. No. 36302032

ORIGINAL SCALE IS IN INCHES
 Drawing name: Z:\Civil 3D Projects\36302032_Shakori\Engineering\WPLAN\Shakori_UST_Layout.dwg Layout Tab: L-1_LAYOUT Apr 17, 2026 - 2:56pm dpcodell
 FOR REDUCED PLANS
 2
 1
 0

UTILITY LEGEND

- g—g— GAS
- ug—ug— COMPRESSED AIR
- ue—ue— UNDERGROUND ELECTRICAL
- sd—sd— STORM DRAIN

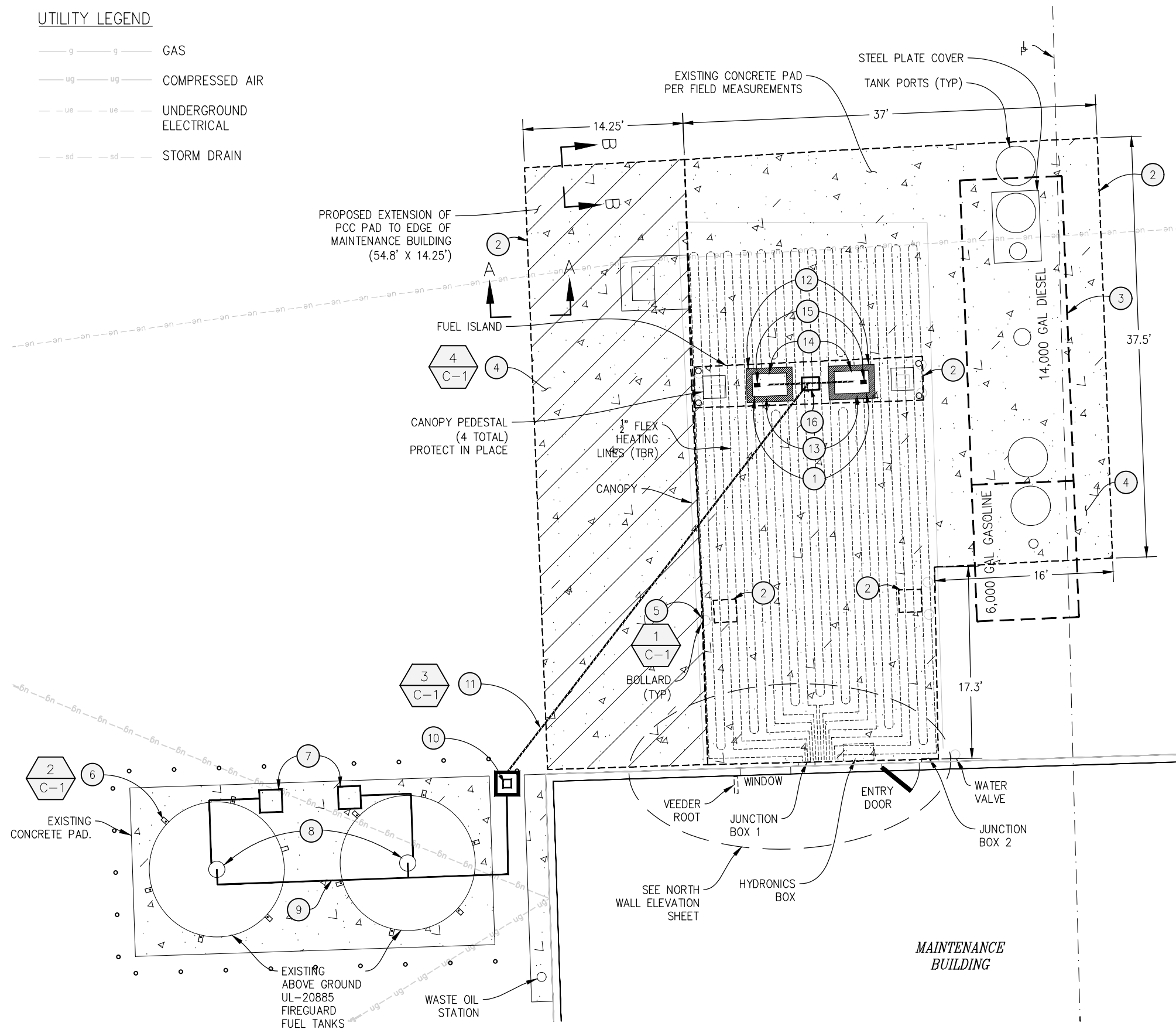

CONSTRUCTION NOTES:

- 1 — REMOVE TWO (2) EXISTING FUEL DISPENSERS AND ASSOCIATED PIPING.
- 2 — SAWCUT AND REMOVE CONCRETE SURROUNDING THE EXISTING FUEL ISLAND. LEAVE CANOPY PEDESTALS INTACT. PROTECT IN PLACE. REMOVE EXISTING HYDRONIC HEATING SYSTEM EMBEDDED IN CONCRETE SLAB. SAWCUT AND REMOVE ASPHALT WITHIN CONCRETE PAD EXTENSION AREA. OVEREXCAVATE AN ADDITIONAL 6" OF NATIVE MATERIAL TO ALLOW FOR INSTALLATION OF AB SECTION PER DETAIL 4 SHEET 2. EXCAVATED MATERIAL MAY BE USED FOR BACKFILL.
- 3 — REMOVE EXISTING 20,000-GALLON FIBERGLASS DOUBLE-WALL UST (SPLIT 14K/6K) AND ASSOCIATED PLUMBING. PERFORM SOIL SAMPLING PER TITLE 23 CCR AND EL DORADO COUNTY ENVIRONMENTAL MANAGEMENT DEPARTMENT OVERSIGHT. BACKFILL VOID FROM TANK REMOVAL. GRADE AND COMPACT NATIVE SUBGRADE TO 95% RELATIVE COMPACTION 18" BELOW EXISTING GRADE.
- 4 — CONSTRUCT 12" PCC SLAB TO MATCH EXISTING GRADE WITH 3600 PSI CONCRETE. EXTEND PCC SLAB 14.25' ON WEST SIDE TO PARALLEL EDGE OF MAINTENANCE BUILDING. PLACE 6" THICK AB (CLASS 2) COMPACTED TO 95% BELOW SLAB. INSTALL REINFORCED STEEL. INSTALL HYDRONIC HEATING SYSTEM WITHIN PCC SLAB INCLUDING INSULATION, TUBING, GLYCOL MIX, AND COMMISSIONING PER LOCAL CODE. DETAIL 4 SHEET C-1.
- 5 — REMOVE AND REPLACE STEEL BOLLARDS (8) EA AROUND CANOPY PEDESTALS. DETAIL 1 SHEET C-1.
- 6 — INSTALL ANCHORAGE CLIP PLATE ASSEMBLIES FOR TWO (2) EX UL-20855 FIREGUARD TANKS WITH SEISMIC HOLD-DOWNS PER TANK MANUFACTURER'S SPECIFICATIONS. DETAIL 2 SHEET C-1.
- 7 — INSTALL REMOTE FILL BOXES FOR EACH TANK ON SLAB.
- 8 — INSTALL TWO (2) EA TURBINE PUMPS (FE-STPAG150-VL3, 1.5 HP) ON THE TOP OF THE FUEL TANKS AND INSTALL NECESSARY EMERGENCY VENTS AND CORRESPONDING FITTINGS.
- 9 — CONNECT PUMPS TO A COMMON MANIFOLD FEEDING A SINGLE UNDERGROUND PRODUCT LINE TO TWO (2) EA BENNETT DIESEL DISPENSERS.
- 10 — INSTALL TRANSITION SUMP WITH SENSOR FOR LEAK DETECTION PER MANUFACTURING AND CODE REQUIREMENTS.
- 11 — INSTALL UNDERGROUND DOUBLE-WALL PIPING FROM TRANSITION SUMP TO DISPENSERS PER CA FIRE CODE AND NATIONAL FIRE PROTECTION ASSOCIATIONS 30A STANDARD. DETAIL 3 SHEET C-1.
- 12 — INSTALL SECONDARY CONTAINMENT SUMPS FOR DISPENSERS (DP-1123B).
- 13 — INSTALL VALVE STABILIZER KITS (SBK1100J).
- 14 — INSTALL TWO (2) EA BENNETT DIESEL DISPENSERS.
- 15 — INSTALL MORRISON CLOCK GAUGES ON EACH TANK.
- 16 — INSTALL FUELMASTER FMU-2500PLUSG KEYPAD SYSTEM AND INTEGRATE TMS2000 PNEUMERCATOR BASE UNIT FOR LEAK DETECTION. CONNECT SUMP SENSORS AND ALARMS FOR CONTAINMENT MONITORING.

SITE PLAN
SCALE : 1" = 5'

REVISION	NUMBER	DATE	DESCRIPTION	BY

PREPARED UNDER THE SUPERVISION OF :
 REGISTERED CIVIL ENGINEER
 DATE: _____

DESIGNED: DES
 DRAWN: DMG
 CHECKED: CHK
 DATE: 2/10/26
 ROAD NUMBER: ####



COUNTY OF EL DORADO
DEPARTMENT OF TRANSPORTATION

1121 SHAKORI DR, SOUTH LAKE TAHOE
FUEL TANK AND DISPENSER INSTALLATION
AND REMOVAL OF EXISTING SYSTEM

SHEET
L-1
1 OF 3
W.O. No. 36302032

CONSTRUCTION NOTES:

- ① — RUN ALL CONDUIT ABOVE GROUND ALONG EXTERIOR WALL OF BUILDING SOUTH OF ISLAND, CONNECTING TO MAIN ELECTRICAL PANEL LOCATED IN THE BUILDING DIRECTLY SOUTH OF THE FUEL ISLAND.
- ② — PROVIDE POWER AND CONTROLS FOR PUMPS, DISPENSERS, FUELMASTER SYSTEM, AND MONITORING EQUIPMENT.
- ③ — INSTALL EMERGENCY STOP BUTTON OR SWITCH ON BUILDING EXTERIOR.

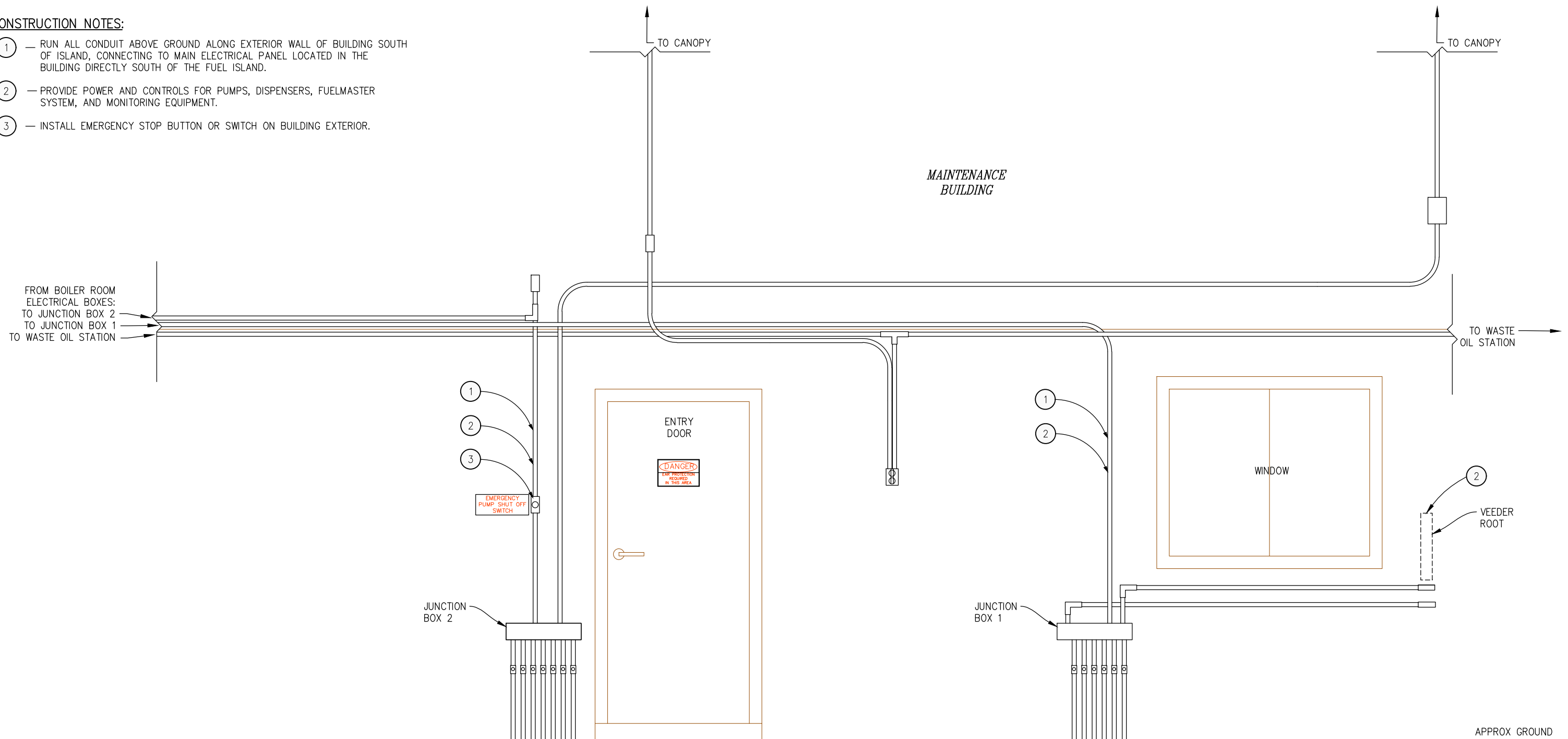

NORTH WALL ELEVATION

ORIGINAL SCALE IS IN INCHES
Drawing name: Z:\Civil 3D Projects\36302032_Shakori\Engineering\WPLAN\Shakori_UST_Layout.dwg Layout Tab: L-2_PROFILE Apr 17, 2026 3:07pm dpoedell

FOR REDUCED PLANS

PROFILE SCALE : 1" = 1'

REVISION	NUMBER	DATE	DESCRIPTION	BY

PREPARED UNDER THE SUPERVISION OF :	DESIGNED: DES	DRAWN: DMG
REGISTERED CIVIL ENGINEER	CHECKED: CHK	DATE: 2/10/26
DATE:	ROAD NUMBER: ####	



COUNTY OF EL DORADO
DEPARTMENT OF TRANSPORTATION

1121 SHAKORI DR, SOUTH LAKE TAHOE
FUEL TANK AND DISPENSER INSTALLATION
AND REMOVAL OF EXISTING SYSTEM

SHEET	L-2
2 OF 3	
W.O. No.	36302032



PROPOSAL

(to be submitted with Bidder's Security)

**TO: COUNTY OF EL DORADO,
STATE OF CALIFORNIA
DEPARTMENT OF TRANSPORTATION,**

for the

**SLT FUEL TANK AND DISPENSER INSTALLATION AND REMOVAL OF EXISTING
SYSTEM
CONTRACT No. – 10197**

THIS IS A SAMPLE OF WHICH DETAILS ALL THE NECESSARY INFORMATION NEEDED FOR A COMPLETE PROPOSAL. PLEASE LOG ONTO QUEST AND COMPLETE ALL ELECTRONIC FORMS UNDER QUEST PROJECT #9811559. PLEASE NOTE THAT SOME FORMS WILL NEED TO BE DOWNLOADED AND RE-UPLOADED WITH ALL THE NECESSARY INFORMATION FILLED OUT. IF YOU ARE NOT UTILIZING SURETY2000, THEN A PDF OF YOUR BIDDERS BOND WILL NEED TO BE UPLOADED AT THE TIME OF BID AND A HARD COPY WILL NEED TO BE RECEIVED BY COUNTY BY END OF BUSINESS DAY ON THE FIRST BUSINESS DAY AFTER THE BID OPENING.

COMPLETING DOWNLOADED BID FORMS IN PENCIL, ERASURES, OVERWRITES, AND USE OF CORRECTION FLUID OR TAPE (WHITE OUT) ARE NOT ACCEPTABLE. BID PROPOSALS WITH PENCIL, ERASURES, OVERWRITES, OR USE OF CORRECTION FLUID OR TAPE (WHITE OUT) MAY BE REJECTED. ALL CHANGES MUST BE LINED OUT AND CORRECTIONS INSERTED ADJACENT TO AND INITIALED BY THE BIDDER'S AUTHORIZED REPRESENTATIVE.

NAME OF BIDDER _____

MAILING ADDRESS _____

CITY, STATE, ZIP _____

PHYSICAL ADDRESS _____

(Please include even if Mailing Address used)

CITY, STATE, ZIP _____

TELEPHONE NO: AREA CODE () _____

FAX NO: AREA CODE () _____

EMAIL ADDRESS _____

The project is located in various areas of El Dorado County, CA. The Work to be done is shown in Exhibits A through D in accordance with these Contract Documents. The Contract Documents consist of: (a) the Notice to Bidders; (b) the bid forms which include the accepted Proposal, Bid Price Schedule and Total Bid, Subcontractor List, Section 10285.1 Statement, Section 10162 Questionnaire, Section 10232 Statement, Noncollusion Affidavit, the Contract which includes this Agreement with all Exhibits thereto, including, the

Bidders' Bond, Performance Bond, and Payment Bond; (c) the State of California Department of Transportation (Caltrans) Standard Plans 2024, and Standard Specifications 2024, the Manual of Uniform Traffic Control Devices (MUTCD), and standard drawings from the Design and Improvement Standards Manual of the County of El Dorado, revised March 8, 1994 including Resolution 199-91 and Resolution 58-94 to adopt changes to the Design and Improvement Standards Manual; (d) all Addenda incorporated in those documents before their execution, and all Contract Change Orders issued in accordance with the Contract Documents which may be delivered or issued after the Effective Date of this Agreement and are not attached hereto; (e) the prevailing Labor Surcharge And Equipment Rental Rates (when required) as determined by Caltrans to be in effect on the date the Work is accomplished; (f) executed Certificate of Insurance forms; (g) an executed Department of the Treasury Internal Revenue Service Form W-9 or County Payee Data Record Form, whichever is applicable; (h) all the obligations of County and of Contractor which are fully set forth and described therein; and all Contract Documents which are hereby specifically referred to and by such reference made a part hereof. All Contract Documents are intended to cooperate so that any work called for in one and not mentioned in the other is to be executed the same as if mentioned in all Contract Documents. Contractor agrees to perform all of its promises, covenants, and conditions set forth in the Contract Documents, and to abide by and perform all terms and conditions set forth therein. In case of conflict between this Agreement and any other contract document, this Agreement shall take precedence. In case of conflict between any contract documents other than this Agreement, the documents shall take precedence in the order identified above, beginning with (a) and ending with (h). The Contract Documents for the work to be done are entitled:

**SLT FUEL TANK AND DISPENSER INSTALLATION AND REMOVAL OF EXISTING
SYSTEM
CONTRACT NO. – 10197**

Bids are to be submitted for the entire work.

The Bidder shall set forth for each unit basis item of work a unit price and a total for the item, and for each lump sum item a total for the item, all in clearly legible figures in the respective spaces provided for this purpose. In the case of unit basis items, the amount set forth under the "Item Total" column shall be the product of the unit price bid and the estimated quantity for the item.

In case of discrepancy between the item price and the total set forth for a unit basis item, the unit price shall prevail, except as provided in (a) or (b), as follows:

- (a) If the amount set forth as a unit price is unreadable or otherwise unclear, or is omitted, or is the same as the amount as the entry in the item total column, then the amount set forth in the total column for the item shall prevail and shall be divided by the estimated quantity for the item and the price thus obtained shall be the unit price;
- (b) (Decimal Errors) If the product of the entered unit price and the estimated quantity is exactly off by a factor of ten, one hundred, etc., or one-tenth, or one-hundredth, etc., from the entered total, the discrepancy will be resolved by using the entered unit price or item total, whichever most closely approximates percentage wise the unit price or item total in the Community Development Services, Transportation Division's Final Estimate of cost.

If this Proposal is accepted and the undersigned Bidder fails to enter into the Contract and furnish the two bonds in the sums required by required by Civil Code Section 9550 and Public Contract Code Section 20129(b), with surety satisfaction to the County of El Dorado and in accordance with the Special Provisions within ten (10) days, not including Saturdays, Sundays, and legal holidays, of the date of the letter notice from the County of El Dorado that the Contract has been awarded, the County of El Dorado may, at its sole option, determine that the Bidder has abandoned the Contract, and thereupon this Proposal and the acceptance thereof shall be null and void and the forfeiture of such security accompanying this Proposal shall operate and the same shall be the property of the County of El Dorado.

The undersigned, as Bidder, declares under penalty of perjury under the laws of the State of California that the only persons or parties interested in this Proposal, as principals, are those named herein; that this Proposal is made without collusion with any other person, firm, or corporation; that it has carefully examined the location of the proposed work, the annexed proposed form of Contract, therein referred to; and that it proposes, and agrees if this Proposal is accepted, that it will contract with the County of El Dorado, in the form of the copy of the Draft Agreement annexed hereto, to provide all necessary machinery, tools, apparatus, and other means of construction, and to do all the work and furnish all the materials specified in the Agreement, in the manner

and time therein prescribed, and according to the requirements of the Engineer as therein set forth, and that it will take in full payment therefore the following item prices, to wit:

**PROPOSAL PAY ITEMS AND BID PRICE SCHEDULE
SLT FUEL TANK AND DISPENSER INSTALLATION AND REMOVAL OF EXISTING SYSTEM
CONTRACT NO. – 10197**

BASE BID

ITEM NO.		ITEM DESCRIPTION	UNIT OF MEASURE	ESTIMATED QUANTITY	UNIT PRICE (IN FIGURES)	ITEM TOTAL (IN FIGURES)
1	130100	JOB SITE MANAGEMENT / MOBILIZATION	LS	1		
2	898000	REMOVE ASPHALT CONCRETE PAVEMENT	LS	1		
3	52010	BAR REINFORCING STEEL	LF	5900		
4	510050	STRUCTURAL CONCRETE	CY	105		
5	280010	POPCORN SLURRY	CY	3		
6		SECONDARY CONTAINMENT SUMPS (DP-1123B)	EACH	2		
7		TRANSITION SUMP WITH MONITORING (PSTF-4630)	EACH	1		
8		PERMITTING COSTS	LS	1		
9	203100	SOIL TESTING	LS	1		
10	260203	2" AB	CY	50		
11	480600	SHORING	LS	1		
12	208006	2" EPOXY COATED BLACK STEEL PIPE	LF	120		
13	208598	2" DOUBLE WALL FIBERGLASS PIPE	LF	70		
14	208601	PIPE BOLLARD	EACH	8		
TOTAL FOR BASE BID						

(NOTICE: Bidders failure to execute the questionnaires and statements contained in this proposal as required by applicable laws and regulations, or the determinations by County of El Dorado based upon those questionnaires and statements, may prohibit award of the subject Contract to the bidder.)

SUBCONTRACTOR LIST

The Bidder must list the name, address, license number, and DIR number of each subcontractor to whom the Bidder proposes to subcontract portions of the Work in excess of 0.5% of the total bid or \$10,000.00 whichever is greater, in accordance with the Public Contract Code commencing with Section 4100 and as required by the Contract Documents. The Bidder must also list the Work portion to be performed by each subcontractor by listing the bid item number, bid item description, and portion of the Work to be performed by the subcontractor in the form of a percentage calculated by dividing the Work to be performed by the subcontractor by the respective bid item amount(s) (not by the total bid price).

Firm Name Address City, State, Zip Code	Phone Fax	License No. DIR No.	Bid Item Number Bid Item Description	Percentage of Each Bid Item Subcontracted
<i>Name</i>	<i>Phone</i>	<i>License No.</i>		
<i>Address</i>	<i>Fax</i>	<i>DIR No.</i>		
<i>City, State, Zip Code</i>				
<i>Name</i>	<i>Phone</i>	<i>License No.</i>		
<i>Address</i>	<i>Fax</i>	<i>DIR No.</i>		
<i>City, State, Zip Code</i>				
<i>Name</i>	<i>Phone</i>	<i>License No.</i>		
<i>Address</i>	<i>Fax</i>	<i>DIR No.</i>		
<i>City, State, Zip Code</i>				

ATTACHMENT I – PUBLIC RECORDS ACT EXEMPTIONS
(ONLY COMPLETE IF YOU ARE REQUESTING EXEMPTION(S))

BIDDER NAME _____

ADDRESS _____

TEPEPHONE NO. _____

Proposer requests that specific portions of the contents of this Proposal be held confidential and not subject to public disclosure pursuant to the Public Records Act. The specific portions are detailed below: (Please identify and list your exemptions by indicating the Section or Paragraph number, and Page number, of the Proposal where the content is contained.) **Each stated exemption must include a citation to supporting legal authority, including statutory authority or case law, to support exemption from the Public Records Act. Requested exemptions that does not meet the requirements of this section will not be considered.**

Public Contract Code Section 10285.1 Statement

In conformance with Public Contract Code Section 10285.1 (Chapter 376, Stats. 1985), the Bidder hereby declares under penalty of perjury under the laws of the State of California that the Bidder has _____, has not _____ been convicted within the preceding three years of any offenses referred to in that section, including any charge of fraud, bribery, collusion, conspiracy, or any other act in violation of any state or Federal antitrust law in connection with the bidding upon, award of, or performance of, any public works contract, as defined in Public Contract Code Section 1101, with any public entity, as defined in Public Contract Code Section 1100, including the Regents of the University of California or the Trustees of the California State University. The term "Bidder" is understood to include any partner, member, officer, director, responsible managing officer, or responsible managing employee thereof, as referred to in Section 10285.1.

Note: The Bidder must place a check mark after "has" or "has not" in one of the blank spaces provided. The above Statement is part of the Proposal. Signing this Proposal on the signature portion thereof shall also constitute signature of this Statement. Bidders are cautioned that making a false certification may subject the certifier to criminal prosecution.

Public Contract Code Section 10162 Questionnaire

In conformance with Public Contract Code Section 10162, the Bidder shall complete, under penalty of perjury, the following questionnaire:

Has the Bidder, any officer of the Bidder, or any employee of the Bidder who has a proprietary interest in the Bidder, ever been disqualified, removed, or otherwise prevented from bidding on, or completing a federal, state, or local government project because of a violation of law or a safety regulation?

Yes _____ No _____

If the answer is yes, explain the circumstances in the following space:

Public Contract Code Section 10232 Statement

In conformance with Public Contract Code Section 10232, the Bidder hereby states under penalty of perjury under the laws of the State of California that no more than one final unappealable finding of contempt of court by a Federal Court has been issued against the Bidder within the immediately preceding two year period because of the Bidder's failure to comply with an order of a Federal Court which orders the Bidder to comply with an order of the National Labor Relations Board.

Note: The above Statement and Questionnaire are part of the Proposal. Signing this Proposal on the signature portion thereof shall also constitute signature of this Statement and Questionnaire.
Bidders are cautioned that making a false certification may subject the certifier to criminal prosecution.

NONCOLLUSION AFFIDAVIT

(Title 23 United States Code Section 112 and
Public Contract Code Section 7106)

The undersigned declares:

I am the _____ of _____, the party making the foregoing bid.

The bid is not made in the interest of, or on behalf of, any undisclosed person, partnership, company, association, organization, or corporation. The bid is genuine and not collusive or sham. The bidder has not directly or indirectly induced or solicited any other bidder to put in a false or sham bid. The bidder has not directly or indirectly colluded, conspired, connived, or agreed with any bidder or anyone else to put in a sham bid, or to refrain from bidding. The bidder has not in any manner, directly or indirectly, sought by agreement, communication, or conference with anyone to fix the bid price of the bidder or any other bidder, or to fix any overhead, profit, or cost element of the bid price, or of that of any other bidder. All statements contained in the bid are true. The bidder has not, directly or indirectly, submitted his or her bid price or any breakdown thereof, or the contents thereof, or divulged information or data relative thereto, to any corporation, partnership, company, association, organization, bid depository, or to any member or agent thereof, to effectuate a collusive or sham bid, and has not paid, and will not pay, any person or entity for such purpose.

Any person executing this declaration on behalf of a bidder that is a corporation, partnership, joint venture, limited liability company, limited liability partnership, or any other entity, hereby represents that he or she has full power to execute, and does execute, this declaration on behalf of the bidder.

I declare under penalty of perjury under the laws of the State of California that the foregoing is true and correct and that this declaration is executed on _____[date], at _____[city], _____[state].

NOTE:

The above Noncollusion Declaration is part of the Proposal and required by Title 23 United States Code Section 112 and Public Contract Code Section 7106. Signing this Proposal on the signature portion thereof shall also constitute signature of this Noncollusion Declaration.

Bidders are cautioned that making a false certification may subject the certifier to criminal prosecution.

YEAR _____

Withholding Exemption Certificate

CALIFORNIA
FORM

20[]

(This form can be used to certify exemption from nonresident withholding under California R&TC Section 18662. This form cannot be used for exemption from wage withholding.)

590

File this form with your withholding agent. (Please type or print)		Withholding agent's name	
Vendor/Payee's name		Vendor/payee's <input type="checkbox"/> SOS no. <input type="checkbox"/> California corp. no.	<input type="checkbox"/> Social Security number <input type="checkbox"/> FEIN
Vendor/Payee's Address (Number and Street)		APT no.	Private Mailbox no.
City		Vendor/Payee's daytime telephone no. ()	
State		ZIP Code	

I certify that for the reasons checked below, the entity or individual named on this form is exempt from the California income tax withholding requirement on payment(s) made to the entity or individual. Read the following carefully and check the box that applies to the vendor/payee:

Individuals – Certification of Residency

I am a resident of California and I reside at the address shown above. If I become a nonresident at any time, I will promptly inform the withholding agent. See instructions for Form 590, General Information D, for the definition of a resident.

Corporations:

The above-named corporation has a permanent place of business in California at the address shown above or is qualified through the California Secretary of State to do business in California. The corporation will withhold on payments of California source income to nonresidents when required. If this corporation ceases to have a permanent place of business in California or ceases to be qualified to do business in California, I will promptly inform the withholding agent. See instructions for Form 590, General Information E, for the definition of permanent place of business.

Partnerships:

The above-named partnership has a permanent place of business in California at the address shown above or is registered with the California Secretary of State, and is subject to the laws of California. The partnership will file a California tax return and will withhold on foreign and domestic nonresident partners when required. If the partnership ceases to do any of the above, I will promptly inform the withholding agent. Note: For withholding purposes, a Limited Liability Partnership is treated like any other partnership.

Limited Liability Companies (LLC):

The above-named LLC has a permanent place of business in California at the address shown above or is registered with the California Secretary of State, and is subject to the laws of California. The LLC will file a California tax return and will withhold on foreign and domestic nonresident members when required. If the LLC ceases to do any of the above, I will promptly inform the withholding agent.

Tax-Exempt Entities:

The above-named entity is exempt from tax under California R&TC Section 23701 _____ (insert letter) or Internal Revenue Code Section 501(c) _____ (insert number). The tax-exempt entity will withhold on payments of California source income to nonresidents when required. If this entity ceases to be exempt from tax, I will promptly inform the withholding agent.
Note: Individuals cannot be tax-exempt entities.

Insurance Companies, IRAs, or Qualified Pension/Profit Sharing Plans:

The above-named entity is an insurance company, IRA, or a federally qualified pension or profit-sharing plan.

California Irrevocable Trusts:

At least one trustee of the above-named irrevocable trust is a California resident. The trust will file a California fiduciary tax return and will withhold on foreign and domestic nonresident beneficiaries when required. If the trustee becomes a nonresident at any time, I will promptly inform the withholding agent.

Estates – Certification of Residency of Deceased Person:

I am the executor of the above-named person's estate. The decedent was a California resident at the time of death. The estate will file a California fiduciary tax return and will withhold on foreign and domestic nonresident beneficiaries when required.

CERTIFICATE: Please complete and sign below.

Under penalties of perjury, I hereby certify that the information provided herein is, to the best of my knowledge, true and correct. If conditions change, I will promptly inform the withholding agent.

Vendor/Payee's name and title (type or print) _____

Vendor/Payee's signature ► _____

Date _____

Instructions for Form 590

Withholding Exemption Certificate

References in these instructions are to the California Revenue and Taxation Code (R&TC).

General Information

A Purpose

Use Form 590 to certify an exemption from nonresident withholding. Complete and present Form 590 to the withholding agent. The withholding agent will then be relieved of the withholding requirements if the agent relies in good faith on a completed and signed Form 590 unless told by the Franchise Tax Board (FTB) that the form should not be relied upon.

Important – This form cannot be used for exemption from wage withholding. Any questions regarding wage withholding should be directed to the California Employment Development Department.

Do not use Form 590 if you are a seller of California real estate. Sellers of California real estate should use Form 593-C, Real Estate Withholding Certificate.

B Law

R&TC Section 18662 requires withholding of income or franchise tax on payments of California source income made to nonresidents of California.

Withholding is required on:

- Payments to nonresidents for services rendered in California;
- Distributions of California source income made to domestic nonresident partners and members and allocations of California source income made to foreign partners and members;
- Payments to nonresidents for rents if the payments are made in the course of the withholding agent's business;
- Payments to nonresidents for royalties for the right to use natural resources located in California;
- Distributions of California source income to nonresident beneficiaries from an estate or trust; and
- Prizes and winnings received by nonresidents for contests in California.

For more information on withholding and waiver requests, get FTB Pub. 1017, Nonresident Withholding Partnership Guidelines, and FTB Pub. 1023, Nonresident Withholding Independent Contractor, Rent and Royalty Guidelines. To get a withholding publication see General Information G.

C Who can Execute this Form

Form 590 can be executed by the entities listed on this form.

Note: In a situation where payment is being made for the services of a performing entity, this form can only be completed by the performing entity or the performing entity's partnership or corporation. It cannot be completed by the performing entity's agent or other third party.

Note: The grantor of a revocable/grantor trust shall be treated as the vendor/payee for withholding purposes. Therefore, if the vendor/payee is a revocable/grantor trust and one or more of the grantors is a nonresident, withhold

ng is required. If all of the grantors of a revocable/grantor trust are residents, no withholding is required. Resident grantors can check the box on Form 590 labeled "Individuals— Certification of Residency."

D Who is a Resident

A California resident is any individual who is in California for other than a temporary or transitory purpose or any individual domiciled in California who is absent for a temporary or transitory purpose.

An individual domiciled in California who is absent from California for an uninterrupted period of at least 546 consecutive days under an employment-related contract is considered outside California for other than a temporary or transitory purpose.

Note: Return visits to California that do not total more than 45 days during any taxable year covered by the employment contract are considered temporary.

This provision does not apply if an individual has income from stocks, bonds, notes, or other intangible personal property in excess of \$200,000 in any taxable year in which the employment-related contract is in effect.

A spouse who is absent from California for an uninterrupted period of at least 546 days to accompany a spouse who is under an employment related contract is considered outside of California for other than a temporary or transitory purpose.

Generally, an individual who comes to California for a purpose which will extend over a long or indefinite period will be considered a resident. However, an individual who comes to perform a particular contract of short duration will be considered a nonresident. For assistance in determining resident status, get FTB Pub. 1031, Guidelines for Determining Resident Status, or call the Franchise Tax Board at (800) 852-5711 or (916) 845-6500 (not toll-free).

E What is a Permanent Place of Business

A corporation has a permanent place of business in California if it is organized and existing under the laws of California or if it is a foreign corporation qualified to transact intrastate business by the California Secretary of State. A corporation that has not qualified to transact intrastate business (e.g., a corporation engaged exclusively in interstate commerce) will be considered as having a permanent place of business in California only if it maintains a permanent office in California that is permanently staffed by its employees.

F Withholding Agent

Keep Form 590 for your records. Do not send this form to the FTB unless it has been specifically requested.

Note: If the withholding agent has received Form 594, Notice to Withhold Tax at Source, only the performing entity can complete and

sign Form 590 as the vendor/payee. If the performing entity completes and signs Form 590 indicating no withholding requirement, you must send a copy of Form 590 with Form 594 to the FTB.

For more information, contact the Withholding Services and Compliance Section. See General Information G.

The vendor/payee must notify the withholding agent if:

- The individual vendor/payee becomes a nonresident;
- The corporation ceases to have a permanent place of business in California or ceases to be qualified to do business in California;
- The partnership ceases to have a permanent place of business in California;
- The LLC ceases to have a permanent place of business in California; or
- The tax-exempt entity loses its tax-exempt status.

The withholding agent must then withhold. Remit the withholding using Form 592-A, Nonresident Withholding Remittance Statement, and complete Form 592, Nonresident Withholding Annual Return, and Form 592-B, Nonresident Withholding Tax Statement.

G Where to get Publications, Forms, and Additional Information

You can download, view, and print FTB Publications 1017, 1023, 1024, and nonresident withholding forms, as well as other California tax forms and publications not related to nonresident withholding from our Website at:

www.ftb.ca.gov

To have publications or forms mailed to you or to get additional nonresident withholding information, please contact the Withholding Services and Compliance Section.

WITHHOLDING SERVICES AND
COMPLIANCE SECTION FRANCHISE
TAX BOARD
PO BOX 942867
SACRAMENTO CA 94267-0651
Telephone: (888) 792-4900
(916) 845-4900 (not toll-
free) FAX: (916) 845-9512

Assistance for persons with disabilities:

We comply with the Americans with Disabilities Act. Persons with hearing or speech impairments please call TTY/TDD (800) 822-6268.

Asistencia bilingüe en español

Para obtener servicios en español y asistencia para completar su declaración de impuestos/formularios, llame al número de teléfono (anotado arriba) que le corresponde.



County of El Dorado

JOE HARN, CPA
Auditor- Controller

OFFICE OF AUDITOR- CONTROLLER

360 FAIR LANE
PLACERVILLE, CALIFORNIA 95667
Phone: (530) 621-5487 FAX: (530) 295-2535

BOB TOSCANO
Assistant Auditor-Controller

PAYEE DATA RECORD

(Required in lieu of IRS W-9 when receiving payment from the County of El Dorado) Version: April 2014

PAYEE DATA RECORD	INSTRUCTIONS: Complete all information on this form. Sign, date, and return to the address shown at the bottom of this page. Prompt return of the fully completed form will prevent delays in processing payments. Information provided in this form will be used by the County of El Dorado to prepare Information Returns (Forms 1099), for withholding on payments to nonresident payees, and for reporting to the Employment Development Department (EDD).		
	Name (as shown on your income tax return)		
NAME AND ADDRESS	Business name/Doing business as/Disregarded entity name, if different from above		
	Physical address (number, street, and apt. or suite)		Remittance address (if different than physical)
	City, state, zip code		City, state, zip code
	Phone number	Fax number (optional)	Email (optional)
	Check appropriate federal tax classification		
FEDERAL TAX CLASSIFICATION & EXEMPTIONS	<input type="radio"/> Individual / sole proprietor <input type="radio"/> Partnership <input type="radio"/> Trust / estate <input type="radio"/> Other (see instructions) ▶ _____ <input type="radio"/> C Corporation <input type="radio"/> S Corporation If you are a corporation, do you provide legal or medical services? <input type="radio"/> Yes <input type="radio"/> No <input type="radio"/> Limited liability company. Enter the tax classification (C=C Corporation, S=S Corporation, P= Partnership)		
	NOTE: IF YOU ARE A SINGLE MEMBER LLC (DISREGARDED ENTITY), ENTER THE TAX CLASSIFICATION OF THE OWNER IDENTIFIED ON THE NAME LINE.		
	Exempt payee code (if any) – see instructions _____		Exemption from FATCA reporting code (if any) – see instructions _____
TAX IDENTIFICATION NUMBER	Tax Identification number (TIN)		
	Enter your TIN in the appropriate box. If you are an individual or sole proprietor, you must enter your SSN. You may choose to provide your EIN in addition to, but not instead of, the SSN. Single member LLCs (disregarded entities) must enter the TIN of the owner identified on the Name line.		
RESIDENCY STATUS	Check appropriate box for residency status		
	<input type="radio"/> California resident / exempt from nonresident withholding – qualified to do business in California or maintains a permanent place of business in California (attach CA Form 590) <input type="radio"/> California nonresident (see instructions)		
	NOTE: Payments to California nonresidents for services performed in California and for certain rents derived from properties located in California that exceed \$1,500 in a calendar year will be subject to 7% nonresident withholding unless you have obtained a waiver or have been approved for reduced withholding by the Franchise Tax Board. There is no withholding on payments for product and for services performed outside of California.		
	<input type="checkbox"/> Obtained Franchise Tax Board waiver of State withholding (attach a copy if applicable) <input type="checkbox"/> Obtained Franchise Tax Board approval for reduced withholding (attach a copy if applicable)		
CERTIFICATION	California sales tax permit number (required only for California nonresident vendors that charge California sales tax)		
	Under penalties of perjury, I certify that: 1) the TIN shown on this form is my correct taxpayer identification number (or I am waiting for a number to be issued to me) and 2) I am not subject to backup withholding and 3) I am a U.S. citizen or other U.S. person and 4) the FATCA code(s) entered on this form (if any) indicating that I am exempt from FATCA reporting is correct		
	Authorized Payee Representative's Name (Type or Print)		Title
	Signature	Date	Telephone
	Should my residency status or any other information provided above change, I will promptly notify County of El Dorado at the address listed above.		
RETURN FORM TO	Please return completed form to:		
	Department/office:	Department of Transportation	
	Mailing address:	2850 Fairlane Court, Placerville, California 95667	
	Phone:	530.621.5311	Fax:
		Email:	Jennifer.Rimoldi@edcgov.us

PAYEE DATA RECORD	A completed Payee Data Record is required for payments to all entities and will be kept on file at the County of El Dorado Auditor-Controller's Office. Payees who do not wish to complete the Payee Data Record may elect to not do business with the County of El Dorado. If the payee does not complete the form and the required payee data is not otherwise provided, payment may be reduced for federal backup withholding, California backup withholding and California nonresident withholding.
FEDERAL TAX CLASSIFICATION	<p>Check the applicable federal tax classification. Note that if an LLC is disregarded as an entity separate from its owner, enter the appropriate tax classification of the owner identified on the "Name" line.</p> <p>Individual: Enter the name shown on your income tax return. If the account is in joint names, list first, and then circle, the name of the person or entity whose SSN you entered on the form.</p> <p>Sole proprietor: Enter your individual name as shown on your income tax return on the "Name" line. You may enter your business, trade, or "doing business as" name on the "Business name/Doing business as/Disregarded entity name" line.</p> <p>Partnership, C Corporation, or S Corporation: Enter the entity's name on the "Name" line and any business, trade, or "doing business as" name on the "Business name/Doing business as/Disregarded entity name" line.</p> <p>Disregarded entity: Enter the owner's name on the "Name" line. The name of the entity entered on the "Name" line should never be a disregarded entity. The name on the "Name" line must be the name shown on the income tax return on which the income should be reported. Check the appropriate box for the U.S. federal tax classification of the person whose name is entered on the "Name" line (individual/sole proprietor, partnership, C corporation, S corporation, trust/estate).</p> <p>Limited liability company (LLC): If the person identified on the "Name" line is an LLC, check the "Limited Liability Company" box only and enter the appropriate code for the U.S. federal tax classification.</p> <p>Other entities: Enter your business name as shown on required U.S. federal tax documents on the "Name" line. This name should match the name shown on the charter or other legal document creating the entity. You may enter any business, trade or DBA name on the "Business name/Doing business as/Disregarded entity name" line.</p>
EXEMPTIONS	<p>Exemptions: If you are exempt from backup withholding and/or FATCA reporting, enter in the exemptions box any code(s) that may apply to you. Generally, individuals (including sole proprietors) are not exempt from backup withholding. Corporations are exempt from backup withholding for certain payments, such as interest and dividends. Corporations are not exempt from backup withholding for payments made in settlement of payment card or third party network transactions. The following codes identify payees that are exempt from backup withholding: 1 – an organization exempt from tax under section 501(a), any IRA, or a custodial account under section 403(b)(7) if the account satisfies the requirements of section 401(f)(2); 2 – The United States or any of its agencies or instrumentalities; 3 – A state, the District of Columbia, a possession of the United States, or any of their political subdivisions or instrumentalities; 4 – A foreign government or any of its political subdivisions, agencies, or instrumentalities; 5 – A corporation; 6 – A dealer in securities or commodities required to register in the United States, the District of Columbia, or a possession of the United States; 7 – A futures commission merchant registered with the Commodity Futures Trading Commission; 8 – A real estate investment fund; 9 – An entity registered at all times during the tax year under the Investment Company Act of 1940; 10 – A common trust fund operated by a bank under section 584(a); 11 – A financial institution; 12 – A middleman known in the investment community as a nominee or custodian; 13 – A trust exempt from tax under section 664 or described in section 4947.</p> <p>Exemption from FATCA reporting: The following codes identify payees that are exempt from reporting under FATCA. These codes apply to persons submitting this form for accounts maintained outside of the United States by certain foreign financial institutions. Therefore, if you are only submitting this form for an account you hold in the United States, you may leave this field blank. Consult with the person requesting this form if you are uncertain if the financial institution is subject to these requirements. A—An organization exempt from tax under section 501(a) or any individual retirement plan as defined in section 7701(a)(37); B—The United States or any of its agencies or instrumentalities; C—A state, the District of Columbia, a possession of the United States, or any of their political subdivisions or instrumentalities; D—A corporation the stock of which is regularly traded on one or more established securities markets, as described in Reg. section 1.1472-1(c)(1)(i); E—A corporation that is a member of the same expanded affiliated group as a corporation described in Reg. section 1.1472-1(c)(1)(i); F—A dealer in securities, commodities, or derivative financial instruments (including notional principal contracts, futures, forwards, and options) that is registered as such under the laws of the United States or any state.</p>
TAX IDENTIFICATION NUMBER	<p>Enter your tax identification number (TIN) in the appropriate box. If you are a single member LLC that is disregarded as an entity separate from its owner, enter the owner's SSN (or EIN, if the owner has one). Do not enter the disregarded entity's EIN. If the LLC is classified as a corporation or partnership, enter the entity's EIN. The TIN for individuals and sole proprietors is the Social Security Number (SSN). Sole proprietors may provide their EIN in addition to but not instead of a SSN.</p> <p>The County of El Dorado requires that all parties entering into business transactions that may lead to payment(s) from the County provide their Taxpayer Identification Number (TIN). The TIN is also required by the California Revenue and Taxation Code Section 18646 to facilitate tax compliance enforcement activities and the preparation of Form 1099 and other information returns as required by the Internal Revenue Code Section 6109(a).</p>
RESIDENCY STATUS	<p>Are you a California resident or nonresident?</p> <p>A corporation will be defined as a "resident" if it has a permanent place of business in California or is qualified through the Secretary of State to do business in California. A partnership is considered a resident partnership if it has a permanent place of business in California. An estate is a resident if the decedent was a California resident at time of death. A trust is a resident if at least one trustee is a California resident. For individuals and sole proprietors, the term "resident" includes every individual who is in California for other than a temporary or transitory purpose and any individual domiciled in California who is absent for a temporary or transitory purpose. Generally, an individual who comes to California for a purpose that will extend over a long or indefinite period will be considered a resident. However, an individual who comes to perform a particular contract of short duration will be considered a nonresident.</p> <p>Payments to all nonresidents may be subject to withholding. Nonresident payees performing services in California or receiving certain rent, lease, or royalty payments from property (real or personal) located in California will have 7% of their total payments withheld for State income taxes. However, no withholding is required if total payments to the payee are \$1,500 or less for the calendar year or if payment is for product. Nonresidents who have been granted a waiver on payments of California source income from the California Franchise Tax Board must submit a copy of the waiver. For information on Nonresident Withholding, contact the Franchise Tax Board at the numbers listed below:</p> <p style="text-align: center;">Withholding Services and Compliance Section: 1-888-792-4900 Email Address: wscs.gen@ftb.ca.gov For hearing impaired with TTD, call: 1-800-822-6268 Website: www.ftb.ca.gov</p> <p>California nonresidents charging California sales tax are required to provide their California sales tax number.</p>
CERTIFICATION	<p>Provide the name, title, signature, and telephone number of the authorized individual completing this form. Provide the date the form was completed.</p> <p>NOTE: You must cross out item 2 in the certification block if you have been notified by the IRS that you are currently subject to backup withholding because you have failed to report all interest and dividends on your tax return.</p>

Accompanying this proposal is _____
(NOTICE: INSERT THE WORDS "CASH(\$___),"CASHIER'S CHECK," "CERTIFIED CHECK," OR "BIDDERS BOND," AS THE CASE MAY BE)
in amount equal to at least ten percent of the amount of the total bid.

The names of all persons interested in the forging Proposal as principals are as follows:

IMPORTANT NOTICE: If the Bidder or other interested person is a corporation, state legal name of corporation and place of incorporation, also names of the president, secretary, treasurer, and executive officer thereof; if a partnership, state name of partnership, also names of all individual partners; if Bidder or other interested person is an individual, state first and last names in full.

Licensed in accordance with an act providing for the registration of Contractors,

License No. _____ Classification(s) _____

ADDENDA: This Proposal is submitted with respect to the changes to the Contract included in addenda number (s) _____

(Fill in addenda numbers if addenda have been received and insert, in this Proposal, any Proposal Pay Items and Bid Price Schedules that were received as part of the addenda)

By my signature on this Proposal I certify, under penalty of perjury under the laws of the State of California, that the foregoing questionnaire and statements of Public Contract Code Sections 10162, 10232, and 10285.1 are true and correct and that the Bidder has complied with the requirements of Sections 4104 of the Subletting and Subcontracting Fair Practices Act and of Section 8103 of the Fair Employment and Housing Commission Regulations (Chapter 5 of Division 4 of Title 2 of the California Code of Regulations). By my signature on this Proposal I further certify, under penalty of perjury under the laws of the State of California and the United States of America, that the Noncollusion Affidavit required by Title 23 United States Code, Section 112, Iran Contracting Act Certification, "Opt Out of Payment Adjustments for Price Index Fluctuations," Public Contract Code Section 7106, California Form 590, Payee Data Record Form if elected, are true and correct.

The person or persons executing this Proposal on behalf of a corporation or partnership shall be prepared to demonstrate by resolution, article, or otherwise, that such person is or that such persons are appropriately authorized to act in these regards for such corporation or partnership. Such authority shall be demonstrated to the satisfaction of the County of El Dorado.

If the signature is by an agent other than an officer of a corporation or a member of a partnership, a power of attorney authorizing said act by the agent on behalf of his principal shall be submitted with the bid forms; otherwise, the bid may be disregarded as irregular and unauthorized.

The Bidder's execution on the signature portion of this Proposal shall constitute an endorsement and execution of those affidavits, declarations and certifications which are part of this Proposal.

Executed this _____ day of _____, 20__

at _____ County, State of _____



Name and Title of Bidder _____

Name of Firm _____

END OF PROPOSAL

COUNTY OF EL DORADO

BIDDER'S BOND

this form MUST be used

KNOW ALL PEOPLE BY THESE PRESENTS, THAT WE _____

_____, as
PRINCIPAL, and _____

as Surety are held and firmly bound unto the County of El Dorado, a political subdivision of the State of California (hereinafter referred to as "Obligee"), in the penal sum of **TEN (10) PERCENT OF THE AMOUNT OF THE TOTAL BID PRICE** of the Principal above named, submitted by said Principal to the Obligee for the work described below, for the payment of which sum in lawful money of the United States, well and truly to be made to the Obligee, we the Principal and Surety bind ourselves, our heirs, executors, administrators and successors, jointly and severally, firmly by these presents. In no case shall the liability of the Surety hereunder exceed the sum of

TEN PERCENT (10%) OF THE AMOUNT OF THE TOTAL BID PRICE

THE CONDITION OF THIS OBLIGATION IS SUCH, THAT:

WHEREAS, the Principal has submitted the above-mentioned Bid to the Obligee, as aforesaid, for certain construction specifically described as follows, for which bids are to be opened at Placerville, El Dorado County, California, for the construction of the

**SLT FUEL TANK AND DISPENSER INSTALLATION AND REMOVAL OF EXISTING SYSTEM
CONTRACT No. 10197**

NOW, THEREFORE, if the aforesaid Principal is awarded the Contract and, within the time and manner required under the Contract Documents, after the prescribed forms are presented to it for signature, enters into a written contract, in the prescribed form, in accordance with the Bid, and files two bonds with the Obligee, one to guarantee faithful performance and the other to guarantee payment for labor and materials, as required by law, then this obligation shall be null and void; otherwise, it shall remain in full force and virtue.

In the event suit is brought upon this bond by the Obligee and judgment is recovered, the Surety shall pay all costs incurred by the Obligee in such suit, including a reasonable attorney's fee to be fixed by the Court.

IN WITNESS WHEREOF, we have set our hands and seals on this _____ day of _____
20__

Bond No. _____

(seal) _____
Principal

(seal) _____
Surety

Address: _____

(NOTE: Signature of those executing for the Surety shall be properly acknowledged, and accompanied by a Certificate of Acknowledgment.)

SURETY

ACKNOWLEDGMENT

A notary public or other officer completing this certificate verifies only the identity of the individual who signed the document to which this certificate is attached, and not the truthfulness, accuracy, or validity of that document.

State of California

County of _____

On _____ before me, _____,
(here insert name and title of the officer)

personally appeared _____

_____ ,

who proved to me on the basis of satisfactory evidence to be the person(s) whose name(s) is/are subscribed to the within instrument and acknowledged to me that he/she/they executed the same in his/her/their authorized capacity(ies), and that by his/her/their signature(s) on the instrument the person(s), or the entity upon behalf of which the person(s) acted, executed the instrument.

I certify under PENALTY OF PERJURY under the laws of the State of California that the foregoing paragraph is true and correct.

WITNESS my hand and official seal.

Signature _____

(Seal)

DRUG-FREE WORKPLACE CERTIFICATION

STD. 21 (Rev. 10/2019)

CERTIFICATION

I, the official named below, hereby swear that I am duly authorized legally to bind the contractor or grant recipient to the certification described below. I am fully aware that this certification, executed on the date below, is made under penalty of perjury under the laws of the State of California.

CONTRACTOR/BIDDER FIRM NAME	FEDERAL ID NUMBER
BY (Authorized Signature) 	DATE EXECUTED
PRINTED NAME AND TITLE OF PERSON SIGNING	TELEPHONE NUMBER (Include Area Code) ()
TITLE	
CONTRACTOR/BIDDER FIRM'S MAILING ADDRESS	

The contractor or grant recipient named above hereby certifies compliance with Government Code Section 8355 in matters relating to providing a drug-free workplace. The above named contractor or grant recipient will:

1. Publish a statement notifying employees that unlawful manufacture, distribution, dispensation, possession, or use of a controlled substance is prohibited and specifying actions to be taken against employees for violations, as required by Government Code Section 8355(a).
2. Establish a Drug-Free Awareness Program as required by Government Code Section 8355(b), to inform employees about all of the following:
 - (a) The dangers of drug abuse in the workplace,
 - (b) The person's or organization's policy of maintaining a drug-free workplace,
 - (c) Any available counseling, rehabilitation and employee assistance programs, and
 - (d) Penalties that may be imposed upon employees for drug abuse violations.
3. Provide as required by Government Code Section 8355(c), that every employee who works on the proposed contract or grant:
 - (a) Will receive a copy of the company's drug-free workplace policy statement, and
 - (b) Will agree to abide by the terms of the company's statement as a condition of employment on the contract or grant.
4. At the election of the contractor or grantee, from and after the "Date Executed" and until _____^(DATE) (NOT TO EXCEED 36 MONTHS), the state will regard this certificate as valid for all contracts or grants entered into between the contractor or grantee and this state agency without requiring the contractor or grantee to provide a new and individual certificate for each contract or grant. If the contractor or grantee elects to fill in the blank date, then the terms and conditions of this certificate shall have the same force, meaning, effect and enforceability as if a certificate were separately, specifically, and individually provided for each contract or grant between the contractor or grantee and this state agency.