



PLANNING AND BUILDING DEPARTMENT

PLANNING DIVISION

<https://www.edcgov.us/Government/Planning>

PLACERVILLE OFFICE:

2850 Fairlane Court, Placerville, CA 95667

BUILDING

(530) 621-5315 / (530) 622-1708 Fax

bldgdept@edcgov.us

PLANNING

(530) 621-5355 / (530) 642-0508 Fax

planning@edcgov.us

LAKE TAHOE OFFICE:

924 B Emerald Bay Rd

South Lake Tahoe, CA 96150

(530) 573-3330

(530) 542-9082 Fax

NOTICE OF INTENT TO ADOPT A MITIGATED NEGATIVE DECLARATION

NOTICE IS HEREBY GIVEN that the County of El Dorado, as lead agency, has prepared a Mitigated Negative Declaration (MND) for the below referenced Project. The Draft MND analyzes the potential environmental effects associated with the proposed Project in accordance with the California Environmental Quality Act (CEQA). This Notice of Intent (NOI) is to provide responsible agencies and other interested parties with notice of the availability of the Draft MND and solicit comments and concerns regarding the environmental issues associated with the proposed Project.

LEAD AGENCY: County of El Dorado, 2850 Fairlane Court, Placerville, CA 95667

CONTACT: County Planner: Cameron Welch, 530-621-5816

PROJECT: TM21-0001/PD21-0003/Z21-0012/Greenwood Estates

PROJECT LOCATION: The property, identified by Assessor's Parcel Number 082-411-004, consists of a 0.88-acre parcel, located on the west side of Greenwood Lane between Meadow Lane and Merrychase Drive, in the Cameron Park area, Supervisorial District 2.

PROJECT DESCRIPTION: A Tentative Subdivision Map, Planned Development Permit, and Rezone to subdivide an existing 0.88-acre parcel to create ten parcels ranging in size from 3,394 square feet to 4,389 square feet. The project site is currently vacant. Five duplexes (ten housing units) would be constructed on ten lots. The proposed duplexes would be 3,838 square feet per duplex building or 1,919 square feet per unit. Each unit would have its own garage for parking. Design waivers are requested for the proposed roadway section and driveway connection. In addition, 5-foot front and rear setbacks and zero-foot side setbacks are requested. The requested rezone would change the existing zoning Multi-Unit Residential within a Design Review Combining Zone (RM-DC) to Multi-Unit Residential within a Planned Development Combining Zone (RM-PD). Access would be provided from Greenwood Lane. Each parcel will be connected to public sewer and water by expansion of the existing utilities on-site, located along Greenwood Lane, by extending the sewer force main and waterline. Electric/utility services would be provided by connecting to PG&E.

PUBLIC REVIEW PERIOD: The public review period for the Draft MND set forth in CEQA for this project is **30** days, beginning **August 24, 2023**, and ending **September 22, 2023**. Any written comments must be received within the public review period. Copies of the Draft MND for this project may be reviewed and/or obtained in the County of El Dorado Planning and Building Department, 2850 Fairlane Court, Placerville, CA 95667, during normal business hours or online at <https://edc-trk.aspgov.com/etrakit/>. In order to view attachments, please login or create an E-Trakit account and search the project name or application file number in the search box.

Please direct your comments to: County of El Dorado, Planning and Building Department, County Planner: Cameron Welch, 2850 Fairlane Court, Placerville, CA 95667 or EMAIL: planning@edcgov.us

PUBLIC HEARING: A public hearing before the Planning Commission has not been scheduled. Once that date has been determined, a public notice will be issued.

COUNTY OF EL DORADO
PLANNING AND BUILDING DEPARTMENT
KAREN L. GARNER, Director
August 23, 2023

TM21-0001/PD21-0003/Z21-0012/Greenwood Estates
Exhibit U - Proposed Mitigated Negative Declaration and Initial Study



**COUNTY OF EL DORADO
PLANNING AND BUILDING DEPARTMENT
INITIAL STUDY
ENVIRONMENTAL CHECKLIST**

Project Title: Tentative Subdivision Map, Planned Development Permit, and Rezone; TM21-0001/PD21-0003/Z21-0012/ Greenwood Estates

Lead Agency Name and Address: El Dorado County, 2850 Fairlane Court, Placerville, CA 95667

Contact Person: Cameron Welch, Senior Planner

Phone Number: (530) 621-5816

Owner's Name and Address: Cameron Glen Estates, LLC, 2216 Via Subria, Vista, CA 92084

Applicant's Name and Address: Cameron Glen Estates, LLC, 2216 Via Subria, Vista, CA 92084

Project Engineer's Name and Address: Lebeck Engineering, 3430 Robin Lane, Cameron Park, CA 95682

Project Location: 2545 Greenwood Lane. The project is located on the west side of Greenwood Lane between Meadow Lane and Merrychase Drive, in the Cameron Park area, El Dorado County. (Attachment A, B)

Assessor's Parcel Number: 082-411-004 (Attachment C) **Acres:** 0.88-acres

Sections: S:04 T: 09N R: 09E

General Plan Designation: Multi-Family Residential (MFR) (Attachment D)

Zoning: Multi-Unit Residential (RM) within a Design Review Combining Zone (DC) (Attachment E)

Description of Project: A Tentative Subdivision Map, Planned Development Permit, and Rezone to subdivide an existing 0.88-acre parcel to create ten parcels ranging in size from 3,394 square feet to 4,389 square feet. The project site is currently vacant. Five duplexes (ten housing units) would be constructed on ten lots. The proposed duplexes would be 3,838 square feet per duplex building or 1,919 square feet per unit. Each unit would have its own garage for parking. Design waivers are requested for the proposed roadway section and driveway connection. In addition, 5-foot front and rear setbacks and zero-foot side setbacks are requested. The requested rezone would change the existing zoning Multi-Unit Residential within a Design Review Combining Zone (RM-DC) to Multi-Unit Residential within a Planned Development Combining Zone (RM-PD).

Access to the proposed duplexes would be provided from Greenwood Lane. The project includes improvements to Greenwood Lane (i.e., 6-foot-wide sidewalk) and expansion of the existing utilities on-site, located along Greenwood Lane, by extending the public utility lines including sewer force main and waterline. New dry stack masonry retaining walls would be constructed as needed up to 3 feet in height along the northern, western, and southern property lines and in the central portion of the site in a north-south direction. Existing chain link fencing that extends along the back and sides of the site would remain in place. Existing chain link fencing that runs along the entire eastern portion of the site (on Greenwood Lane) would be removed for access and landscaping (Attachment F). A Facilities Improvement Letter (FIL) from the El Dorado Irrigation District (EID) is included with requirements for improvements to connect to public water/sewer service. Storm water runoff for Lots 5 and 6 would be directed to an existing 42-inch storm drain located at the northwest corner of the site. Storm water runoff for the remainder of the site would be directed to water quality vegetative swales constructed adjacent to the Greenwood Lane right-of-way and then subsequently overland to an existing curb and gutter (Attachment F). Electricity/utilities would be provided by connecting to PG&E.

Environmental Setting: The project site is a 0.88-acre parcel located at an elevation of 1,150 to 1,159 feet above mean sea level. Based on a field review conducted in August 2021, topography is relatively flat with gentle slopes. A Biological Resources Evaluation was prepared by Fremont Environmental Consulting dating September 16, 2021 (Attachment 3). Based on results of the report, vegetation on site is primarily defined by non-native annual grassland. The site is vegetated primarily with non-native grasses and forbs typical of disturbed sites within largely developed areas. The dominant species within the non-native annual grassland are non-native grasses including wild oat, soft chess, barley, medusa head, ripgut brome, fescue, and silver European hairgrass. A few large blue oaks grow along the western side of the site along with scattered small coyote bush. Wildlife use of the site is limited to common species adapted to disturbed areas and include several ground squirrel burrows found on the project site. The project site is located in the El Dorado County Rare Plant Mitigation Area 2, and the proposed project could potentially result in impacts to nesting raptors and migratory birds

and/or other nesting birds. No special-status plant or wildlife species were found on the project site. Further discussion is contained within this Initial Study.

Other public agencies whose approval is required (e.g., permits, financing approval, or participation agreement)

1. El Dorado County Department of Transportation
2. El Dorado County Building Services
3. El Dorado County Air Quality Management District
4. El Dorado County Environmental Management
5. El Dorado County Surveyor's Office
6. El Dorado Irrigation District
7. El Dorado County Department of Transportation
8. El Dorado County Stormwater Coordinator, West Slope
9. Cameron Park Fire Protection District/California Department of Forestry and Fire Protection (CAL FIRE)
10. PG&E

Have California Native American tribes traditionally and culturally affiliated with the project area requested consultation pursuant to Public Resources Code section 21080.3.1? If so, has consultation begun?

At the time of the application request, seven tribes had requested to be notified of proposed projects for consultation in the project area: Wilton Rancheria, Ione Band of Miwok Indians, Nashville Enterprise Miwok-Maidu-Nishinam Tribe, Shingle Springs Band of Miwok Indians, United Auburn Indian Community of the Auburn Rancheria, Washoe Tribe of California and Nevada, and T'si-Akim Maidu. None of the Tribes requested formal consultation; however, the United Auburn Indian Community provided recommended language and mitigation measures for undiscovered tribal cultural resources. An initial records search was conducted by searching California Historic Resources Information System (CHRIS) maps for cultural resource site records and survey reports in El Dorado County within a 1/4-mile radius of the proposed project site. It was determined that there is low potential for locating historic-period cultural resources in the immediate vicinity of the proposed project area. Further discussion is contained in this Initial Study under the Cultural Resource and Tribal Cultural Resource analyses.

ENVIRONMENTAL FACTORS POTENTIALLY AFFECTED

The environmental factors checked below would be potentially affected by this project, involving at least one impact that is a "Potentially Significant Impact" as indicated by the checklist on the following pages.

	Aesthetics		Agriculture and Forestry Resources		Air Quality
	Biological Resources		Cultural Resources		Energy
	Geology / Soils		Greenhouse Gas Emissions		Hazards & Hazardous Materials
	Hydrology / Water Quality		Land Use / Planning		Mineral Resources
	Noise		Population / Housing		Public Services
	Recreation		Transportation/Traffic		Tribal Cultural Resources
	Utilities / Service Systems		Wildfires		

DETERMINATION

On the basis of this initial evaluation:

- I find that the proposed project **COULD NOT** have a significant effect on the environment, and a **NEGATIVE DECLARATION** will be prepared.
- I find that although the proposed project could have a significant effect on the environment, there will not be a significant effect in this case because revisions in the project have been made by or agreed to by the project proponent. A **MITIGATED NEGATIVE DECLARATION** will be prepared.

- I find that the proposed project **MAY** have a significant effect on the environment, and an **ENVIRONMENTAL IMPACT REPORT** is required.
- I find that the proposed project **MAY** have a "potentially significant impact" or "potentially significant unless mitigated" impact on the environment, but at least one effect: 1) has been adequately analyzed in an earlier document pursuant to applicable legal standards; and 2) has been addressed by Mitigation Measures based on the earlier analysis as described in attached sheets. An **ENVIRONMENTAL IMPACT REPORT** is required, but it must analyze only the effects that remain to be addressed.
- I find that although the proposed project could have a significant effect on the environment, because all potentially significant effects: a) have been analyzed adequately in an earlier EIR or **NEGATIVE DECLARATION**, pursuant to applicable standards; and b) have been avoided or mitigated pursuant to that earlier EIR or **NEGATIVE DECLARATION**, including revisions or Mitigation Measures that are imposed upon the proposed project, nothing further is required.

Signature: Cameron Welch Date: 8/4/2023

Printed Name: Cameron Welch, Senior Planner For: El Dorado County

Signature: Rob Peters Date: 8/4/23

Printed Name: Rob Peters, Deputy Director For: El Dorado County

PROJECT DESCRIPTION

Throughout this Initial Study, please reference the following Attachments:

Project Specific Plans:

Attachment A: Location Map
Attachment B: Aerial Photo
Attachment C: Assessor's Parcel Map
Attachment D: General Plan Land Use Map
Attachment E: Zoning Map
Attachment F: Development Site Plans (October 22, 2021)

Project Specialty Reports:

Attachment 1: CalEEMod Calculation Output, (June 1, 2022)
Attachment 2: Arborist Report, California Tree and Landscape Consulting, (August 28, 2021)
Attachment 3: Biological Resources Evaluation Memorandum, Fremont Environmental Consulting, (Sept. 16, 2021)
Attachment 4: California Historical Resources Information System Records Search Results for APN: 082-411-004
Attachment 5: Geotechnical Engineering Study, Youngdahl, (February 2022)
Attachment 6: Preliminary Drainage Report, Lebeck Engineering, (September 2021)
Attachment 7: Architectural Plans
Attachment 8: Landscape Plans

Introduction:

This Initial Study has been prepared in accordance with the California Environmental Quality Act (CEQA) to evaluate the potential environmental impacts resulting from the proposed project. The Planned Development (-PD) Combining Zone implements the General Plan by providing innovative planning and development techniques that allow the use of flexible development standards; provide for a combination of different land uses which are complimentary, but may not in all aspects conform to the existing zoning regulations; allow clustering of intensive land uses to minimize impacts on various natural resources; avoid cultural resources where feasible; promote more efficient utilization of land; reflect the character, identity and scale of local communities; protect suitable land for agricultural uses; and minimize use compatibility issues and environmental impacts.

Project Description:

A Tentative Subdivision Map, Planned Development, and Rezone; TM21-0001/PD21-0003/Z21-0012 to allow subdivision of one 0.88-acre lot into ten lots and development of five duplexes (ten housing units) on the ten lots. The lots would range in size from 3,394 square feet to 4,389 square feet. The proposed duplexes would be 3,838 square feet per duplex building or 1,919 square feet per unit. Access to the proposed duplexes would be provided from Greenwood Lane. The project includes improvements to Greenwood Lane (i.e., 6-foot-wide sidewalk) and expansion of the existing utilities on-site (located along Greenwood Lane) by extending the public utility lines including sewer force main and waterline. New dry stack masonry retaining walls would be constructed as needed up to 3 feet in height along the northern, western, and southern property lines. Existing chain link fencing that runs along the entire eastern portion of the site (on Greenwood Lane) would be removed for access and landscaping (Attachment F). A Facilities Improvement Letter (FIL) from the El Dorado Irrigation District (EID) is included with requirements for improvements to connect to public water/sewer service. Storm water runoff for Lots 5 and 6 would be directed to an existing 42-inch storm drain located at the northwest corner of the site. Storm water runoff for the remainder of runoff at the site would be directed to water quality vegetative swales to be constructed adjacent to the Greenwood Lane right-of-way and then subsequently overlaid to an existing curb and gutter (Attachment F). Electricity/utilities would be provided by connecting to PG&E.

Site Description:

The project site is a 0.88-acre parcel located at an elevation of 1,150 to 1,159 feet above mean sea level. The entire parcel would be impacted by the implementation of the proposed project. The following details are based on a staff field visit in April 2022, and a comprehensive analysis contained in the Biological Resources Evaluation prepared by Fremont Environmental Consulting dating September 16, 2021: The project site is located within a commercial/light industrial area in the south side of Cameron Park just north of Highway 50. The surrounding area is a mix of commercial, recreational, and multifamily residential housing. The project site is currently vacant and undeveloped. The project site had been mowed prior to the biological reconnaissance survey, likely in late spring or early summer. Historic aerial imagery indicates that the site has been vacant and undisturbed since at least 1993. The project site is primarily flat and gently sloping from west to east.

Vegetation: Vegetation on the project site is primarily defined by non-native annual grassland. The site is vegetated primarily with non-native grasses and forbs typical of disturbed sites within largely developed areas. The dominant species within the non-native annual grassland are non-native grasses including wild oat, soft chess, barley, medusa head, ripgut brome, fescue, and silver European hairgrass. A few large blue oaks grow along the western side of the site along with scattered small coyote bush.

Soil types: Based on review of the Biological Resources Evaluation prepared for the project, two soil types are mapped on the project site including Auburn silt loam and Sobrante silt loam (Attachment 3). Auburn silt loam is the primary soil type on the site and encompasses the majority of the site with Sobrante silt loam occurring in a small strip along the southeast corner of the site.

Special Status Plants (rare plants): No special-status plant species were observed in the project site during the biological reconnaissance survey. Based on this evaluation, there are no special-status plant species with the potential to occur in the project site.

Special Status Species (wildlife): No special-status animal species were observed in the project site during the biological reconnaissance survey. Based on this evaluation, there are no special-status animal species with the potential to occur in the project site.

Project Location and Surrounding Land Uses:

The project is 0.88 acres and located on the west side of Greenwood Lane between Meadow Lane and Merrychase Drive, in the community of Cameron Park (Attachments A, B). The adjacent-neighboring parcels are zoned Single-unit Residential Zone (R1) to the west, Community Commercial-Design Control (CC-DC) to the north, Multi-unit Residential-Design Control (RM-DC) to the south, and Limited Commercial-Design Control (CL-DC) to the east. To the south are existing apartment complexes, to the north is open space and commercial businesses immediately beyond, to the east is a mix of open space and commercial uses, and to the west are ball fields associated with Camerado Springs Middle School.

Project Characteristics:

1. Transportation/Circulation/Parking

The project was reviewed by the County Department of Transportation (DOT). DOT determined that the project would not require a Transportation Impact Study and issued a waiver. The project was also reviewed by the Cameron Park Fire Department who provided comments/conditions. The Cameron Park Fire Department confirmed the project would comply with their adopted standards including the proposed fire apparatus access road as designed.

Access to the project site would be from one full access driveway along Greenwood Lane. Proposed on-site vehicle and pedestrian circulation would be from a 20-foot-wide drive-isle with two-way traffic through the central portion of the project site. A fire truck turnaround area would be provided in the western portion of the development and would prohibit parking in that area. All vehicle parking would be required to occur in garages or on driveways, excluding the driveway for Lot 8 where parking would not be allowed (Attachment F).

2. Utilities and Infrastructure

Electricity/utilities services would be provided by connecting to Pacific Gas & Electric (PG&E). The El Dorado Irrigation District (EID) reviewed the project and provided conditions for improvements to the existing utilities, on-site, specifically requiring an extension to connect to the sewer line and water line (Attachment F). The County Environmental Management Department (EMD) reviewed the project and provided comments specific to construction/demolition debris recycling.

Public Water/Sewer: The project would be served by public water and sewer service. The El Dorado Irrigation District (EID) reviewed the project and provided comments in their Facility Improvement Letter (FIL) verifying water and sewer connectivity, recommended improvements, and adequacy of the existing system for fire service and fire hydrants. **Water:** The proposed project will require 9 equivalent dwelling units (EDUs) of water. An EDU is defined as one single-family residential household and is the unit by which a user is charged for service. In order to provide and receive service, the project would be required to construct a water line extension connecting to an existing 8-inch water line located in Greenwood Lane, and **Sewer:** There is an 8-inch sewer line located in Greenwood Lane adjacent to the project site. According to the FIL, this sewer line has adequate capacity to serve the proposed project at this time. The project will require 9 EDUs of sewer service. In order for the project to receive service from this sewer line, an extension of facilities of adequate size would be required to be constructed, and **Easements:** Proposed water lines, sewer lines, and related facilities shall be located within an easement and would be required to remain accessible by conventional maintenance vehicles. Easements for any new EID facilities constructed by the project would be required to be granted to EID prior to approval of water and sewer improvements, whether onsite or offsite; and **Fire Hydrants:** The Cameron Park Fire Department reviewed the improvement plans and identified that the location of hydrant(s) shall be approved. The Fire Department also stated that fire hydrant spacing would be required to comply with Section 507 and Appendix C of the California Fire Code.

3. Construction Considerations

The project site has a General Plan land use designation of residential and is zoned for Multi-Unit Residential within a Design Review Combining Zone (RM-DC). The purpose of the DC zone is to regulate the development of land “adjacent to or visible from designated State Scenic Highway corridors or located within community design review areas established by the Board.”

Implementation of the project would change the current Design Review Combining Zone (DC) designation to Planned Development (PD). The purpose of the Planned Development (-PD) Combining Zone is to “implement the General Plan by providing innovative planning and development techniques that allow the use of flexible development standards; provide for a combination of different land uses which are complimentary, but may not in all aspects conform to the existing zoning regulations; allow clustering of intensive land uses to minimize impacts on various natural resources; avoid cultural resources where feasible; promote more efficient utilization of land; reflect the character, identity and scale of local communities; protect suitable land for agricultural uses; and minimize use compatibility issues and environmental impacts.” The proposed uses for residential are allowed uses within the RM-PD zone, is consistent with the multi-unit residential General Plan land use designation, and would be compatible with the existing, surrounding development. Requested modifications to the development standards include design waivers for the proposed roadway section and driveway connection and 5-foot front and rear setbacks.

Grading, Drainage, Utilities: A Preliminary Drainage Report was prepared by Lebeck Engineering, Inc. dated September 2021 (Attachment 6). Preliminary Grading, Drainage, and Utility Plans are included and show the proposed improvements, design flow of drainage system, and all proposed utilities (Attachment F).

Building Elevations and Design: The building elevations and design are shown in the Building Elevations which include the perimeter elevations, conceptual roof plan/parapets, details of the building materials, architectural theme, heights, and paint colors. The proposed duplexes would be constructed of stucco and board and batten siding and composition shingle roofs (Attachment 7). The building would have accents of stone and metal roofing (Attachment 7).

Fencing: Existing chain link fencing that extends along the back and sides of the site would remain in place and hedges would be planted alongside. Existing chain link fencing that extends the front of the site (along Greenwood Lane) would be removed for access and landscaping. In addition, wood fencing that extends the southern edge of the property would be removed (Attachment F).

Landscape Details: A Landscape Plan is included for the proposed project showing approved drought-tolerant plant and tree species that comply with the Landscaping and Irrigation Standards contained in the Community Design Standards, as well as with the County's Model Water Efficient Landscape Ordinance (MWELo) (Attachment 8).

On-Site Lighting and Signage: Proposed lighting for the development area would compose of typical residential lighting consistent with the County's Outdoor Lighting Standards.

Effects of Adjacency to Cameron Park Airport: The subject parcel is located approximately 2 miles from the south end of the runway at Cameron Park Airport, is not located within the Airport Influence Area, and is not adjacent to the runway arrival/departure corridor.

EVALUATION OF ENVIRONMENTAL IMPACTS

1. A brief explanation is required for all answers except "No Impact" answers that are adequately supported by the information sources a lead agency cites in the parentheses following each question. A "No Impact" answer is adequately supported if the referenced information sources show that the impact simply does not apply to projects like the one involved (e.g., the project falls outside a fault rupture zone). A "No Impact" answer should be explained where it is based on project-specific factors as well as general standards (e.g., the project will not expose sensitive receptors to pollutants, based on a project-specific screening analysis).
2. All answers must take account of the whole action involved, including off-site as well as on-site, cumulative as well as project-level, indirect as well as direct, and construction as well as operational impacts.
3. If the lead agency has determined that a particular physical impact may occur, the checklist answers must indicate whether the impact is potentially significant, less than significant with mitigation, or less than significant. "Potentially Significant Impact" is appropriate if there is a fair argument that an effect may be significant. If there are one or more "Potentially Significant Impact" entries when the determination is made, an EIR is required.
4. "Negative Declaration: Less Than Significant With Mitigation Incorporated" applies where the incorporation of Mitigation Measures has reduced an effect from "Potentially Significant Impact" to a "Less Than Significant Impact." The lead agency must describe the Mitigation Measures, and briefly explain how they reduce the effect to a less than significant level.
5. Earlier analyses may be used where, pursuant to the tiering, program EIR, or other CEQA process, an effect has been adequately analyzed in an earlier EIR or negative declaration (Section 15063(c)(3)(D)). In this case, a brief discussion should identify the following:
 - a. Earlier Analysis Used. Identify and state where they are available for review.
 - b. Impacts Adequately Addressed. Identify which effects from the above checklist were within the scope of and adequately analyzed in an earlier document pursuant to applicable legal standards, and state whether such effects were addressed by mitigation measures based on the earlier analysis.
 - c. Mitigation Measures. For effects that are "Less Than Significant With Mitigation Incorporated," describe the mitigation measures which were incorporated or refined from the earlier document and the extent to which they address site-specific conditions for the project.
6. Lead agencies are encouraged to incorporate into the checklist references to information sources for potential impacts (e.g., general plans, zoning ordinances). Reference to a previously prepared or outside document should, where appropriate, include a reference to the page or pages where the statement is substantiated.
7. Supporting Information Sources: A source list should be attached, and other sources used, or individuals contacted should be cited in the discussion.
8. This is only a suggested form, and lead agencies are free to use different formats; however, lead agencies should normally address the questions from this checklist that are relevant to a project's environmental effects in whatever format is selected.
9. The explanation of each issue should identify:
 - a. the significance criteria or threshold, if any, used to evaluate each question; and
 - b. the mitigation measure identified, if any, to reduce the impact to less than significant.

ENVIRONMENTAL IMPACTS

1. AESTHETICS				
Except as provided in Public Resources Code Section 21099, would the project:	Potentially Significant Impact	Less Than Significant with Mitigation	Less Than Significant Impact	No Impact
a) Have a substantial adverse effect on a scenic vista?	<input type="checkbox"/>	<input type="checkbox"/>	<input type="checkbox"/>	<input checked="" type="checkbox"/>
b) Substantially damage scenic resources, including, but not limited to, trees, rock outcroppings, and historic buildings within a state scenic highway?	<input type="checkbox"/>	<input type="checkbox"/>	<input type="checkbox"/>	<input checked="" type="checkbox"/>
c) In non-urbanized areas, substantially degrade the existing visual character or quality of public views of the site and its surroundings? (Public views are those that are experienced from a publicly accessible vantage point). If the project is in an urbanized area, would the project conflict with applicable zoning and other regulations governing scenic quality?	<input type="checkbox"/>	<input type="checkbox"/>	<input checked="" type="checkbox"/>	<input type="checkbox"/>
d) Create a new source of substantial light or glare which would adversely affect day or nighttime views in the area?	<input type="checkbox"/>	<input type="checkbox"/>	<input checked="" type="checkbox"/>	<input type="checkbox"/>

ENVIRONMENTAL SETTING (BASELINE):

The project site is located on Greenwood Lane between Meadow Lane and Merrychase Drive in the Cameron Park community of El Dorado County. Surrounding uses include residential, open space, commercial, and Camerado Springs Middle School. The surrounding lots are primarily open with a few full-grown trees. However, views towards the project site are not obscured from adjacent lots or from the street.

REGULATORY SETTING:

Federal Laws, Regulations, and Policies

No federal regulations are applicable to aesthetics in relation to the proposed project.

State Laws, Regulations, and Policies

In 1963, the California State Legislature established the California Scenic Highway Program, a provision of the Streets and Highways Code, to preserve and enhance the natural beauty of California. The state highway system includes designated scenic highways and those that are eligible for designation as scenic highways. There are no officially designated state scenic corridors in the vicinity of the project site. Highway 49, located 5 miles from the project site, is designated as an Eligible Scenic Highway but is not visible from the project site (Caltrans 2022).

Local Laws, Regulations, and Policies

The County has several standards and ordinances that address issues relating to visual resources of which many can be found in the County Zoning Ordinance (Title 130 of the El Dorado County Code). The Zoning Ordinance consists of descriptions of the zone districts and identifies land uses allowed by right or uses requiring a discretionary permit.

The Zoning Ordinance also identifies specific development standards for each land use that include development attributes for parcel size, density range, required setbacks, maximum building height, and floor area ratio (FAR).

In El Dorado County, visual resources are classified as either scenic resources or scenic views. Scenic resources include specific features of a viewing area (or viewshed) such as trees, rock outcroppings, and historic buildings. Scenic resources are also specific features that act as the focal point of a viewshed and are usually foreground elements. Scenic views are elements of the broader viewshed such as mountain ranges, valleys, and ridgelines. Scenic views are also typically middle ground or background elements of a viewshed that can be seen from a range of viewpoints, often along a roadway or other corridor.

A list of the county's scenic views and resources is presented in Table 5.3-1 of the El Dorado County General Plan EIR (p. 5.3-3). This list includes areas along highways where viewers can see large water bodies (e.g., Lake Tahoe, Folsom Reservoir), river canyons, rolling hills, forests, or historic structures or districts that are reminiscent of El Dorado County's heritage.

Several highways in El Dorado County have been designated by the California Department of Transportation (Caltrans) as scenic highways or are eligible for such designation. These include U.S. 50 from the eastern limits of the Government Center interchange (Placerville Drive/Forni Road) in Placerville to South Lake Tahoe, all of State Route (SR) 89 within the county, and those portions of SR 88 along the southern border of the county.

Rivers in El Dorado County include the American, Cosumnes, Rubicon, and Upper Truckee rivers. A large portion of El Dorado County is under the jurisdiction of the United States Forest Service (USFS), which under the Wild and Scenic Rivers Act may designate rivers or river sections to be Wild and Scenic Rivers. To date, no river sections in El Dorado County have been nominated for or granted Wild and Scenic River status.

APPLICABLE THRESHOLDS OF SIGNIFICANCE:

The significance determination in this aesthetics analysis is based on consideration of: (1) the extent of change related to visibility of the proposed project site from key public vantage points; (2) the degree of visual contrast and compatibility in scale and character between project activities and the existing surroundings; (3) conformance of the proposed project with public policies regarding visual and urban design quality; and (4) potential adverse effects on scenic vistas and scenic resources. A substantial adverse effect to aesthetics would result in the introduction of physical features that are not characteristic of the surrounding development, substantially change the natural landscape, or obstruct an identified public scenic vista.

ENVIRONMENTAL STUDIES PERFORMED AND METHODOLOGY:

Project-specific environmental studies related to aesthetic resources were not prepared for the proposed project. However, the methodology employed for assessing potential aesthetic impacts involved considering the existing viewshed and the project development that has the potential to change the project-area visual character.

IMPACT ANALYSES AND CONCLUSIONS:

- a. **Scenic Vista:** No scenic corridors, vistas, or viewsheds as described in the El Dorado County General Plan, are located in the vicinity of the project site (El Dorado County 2019). In addition, the project site is not adjacent to or visible from a State Scenic Highway. Any new structures would require permits for construction and would comply with regulations and standards of the El Dorado County General Plan and the Zoning Ordinance. For these reasons, **no impact** to a scenic vista would occur.
- b. **Scenic Resources:** The project site is not visible from an officially designated State Scenic Highway or County-designated scenic highway, or any roadway that is part of a corridor protection program (Caltrans 2022). There are no views of the project site from public parks or scenic vistas. It should be noted that Christa McAuliffe Park is located to the south of the project site. However, views from Christa McAuliffe Park toward the project site are obscured by existing development and full-grown trees in the park itself and along nearby roadways. Lastly, there

are no trees or historic buildings that have been identified by the County as contributing to exceptional aesthetic value at the project site. For these reasons, **no impact** to a scenic resource would occur.

- c. **Visual Character:** The adjacent-neighboring parcels are zoned Single-unit Residential Zone (R1) to the west, Community Commercial (CC) to the north, Multi-unit Residential (RM) to the south, and Limited Commercial (CL) to the east. The project site is currently zoned for Multi-unit Residential (RM) within a Design Review Combining Zone (DC). Implementation of the proposed project would rezone the site to RM within a Planned Development (PD).

Zoning Ordinance Section 130.24.010 states the RM zone are “those lands which are most capable of supporting the highest density of development within the County, based on topography, infrastructure, and circulation availabilities and constraints, as well as proximity to employment centers, public facilities, recreation, and shopping. It is applied to regulate and promote the development of multi-unit dwellings, including apartments, condominiums, and townhouses, while ensuring compatibility with surrounding lower density residential neighborhoods.”

Zoning Ordinance Section 130.28.010 states the Planned Development (-PD) Combining Zone “implements the General Plan by providing innovative planning and development techniques that allow the use of flexible development standards; provide for a combination of different land uses which are complimentary, but may not in all aspects conform to the existing zoning regulations; allow clustering of intensive land uses to minimize impacts on various natural resources; avoid cultural resources where feasible; promote more efficient utilization of land; reflect the character, identity and scale of local communities; protect suitable land for agricultural uses; and minimize use compatibility issues and environmental impacts.”

The proposed residential would be a permitted use in the RM-PD zone and would satisfy the overall intent of the RM zone as a high-density residential development in proximity to employment centers, public facilities, recreation, and shopping. The project would also be designed in a manner to fit in with the existing surrounding residential uses by incorporating neutral building colors and landscaping. For these reasons, potential impacts relating to degrading the project area visual character are considered **less than significant**.

- d. **Light and Glare:** The proposed project would produce new light and glare but would be designed to minimize any light and glare impacts by using residential oriented lighting and minimizing the use of reflective materials. This design would maintain minimal light impacts to adjacent uses while also providing sufficient lighting for safety and security on the project site. The proposed project is designed to comply with County lighting ordinance requirements and would be reviewed for compliance at the time of building permit issuance. For these reasons, potential impacts from nighttime lighting and daytime glare are considered **less than significant**.

FINDING: With adherence to regulations and standards of the El Dorado County Municipal Code and General Plan, potential impacts related to aesthetics are anticipated to **be less than significant**.

Resources:

California Department of Transportation (Caltrans). 2022. *California State Scenic Highways*. Available at: <https://dot.ca.gov/programs/design/lap-landscape-architecture-and-community-livability/lap-liv-i-scenic-highways> (Accessed March 3, 2022).

County of El Dorado. 2019. Adopted General Plan. Available at: https://www.edcgov.us/Government/planning/pages/adopted_general_plan.aspx (Accessed October 25, 2022).

2. AGRICULTURE AND FORESTRY RESOURCES				
<p>In determining whether impacts to agricultural resources are significant environmental effects, lead agencies may refer to the California Agricultural Land Evaluation and Site Assessment Model (1997) prepared by the California Dept. of Conservation as an optional model to use in assessing impacts on agriculture and farmland. In determining whether impacts to forest resources, including timberland, are significant environmental effects, lead agencies may refer to information compiled by the California Department of Forestry and Fire Protection regarding the state’s inventory of forest land, including the Forest and Range Assessment Project and the Forest Legacy Assessment project; and forest carbon measurement methodology provided in Forest Protocols adopted by the California Air Resources Board.</p>				
Would the project:	Potentially Significant Impact	Less Than Significant with Mitigation	Less Than Significant Impact	No Impact
a) Convert Prime Farmland, Unique Farmland, or Farmland of Statewide Importance (Farmland), as shown on the maps prepared pursuant to the Farmland Mapping and Monitoring Program of the California Resources Agency, to non-agricultural use?	<input type="checkbox"/>	<input type="checkbox"/>	<input type="checkbox"/>	<input checked="" type="checkbox"/>
b) Conflict with existing zoning for agricultural use, or a Williamson Act contract?	<input type="checkbox"/>	<input type="checkbox"/>	<input type="checkbox"/>	<input checked="" type="checkbox"/>
c) Conflict with existing zoning for, or cause rezoning of, forest land (as defined in Public Resources Code section 12220(g)), timberland (as defined by Public Resources Code section 4526), or timberland zoned Timberland Production (as defined by Government Code section 51104(g))?	<input type="checkbox"/>	<input type="checkbox"/>	<input type="checkbox"/>	<input checked="" type="checkbox"/>
d) Result in the loss of forest land or conversion of forest land to non-forest use?	<input type="checkbox"/>	<input type="checkbox"/>	<input type="checkbox"/>	<input checked="" type="checkbox"/>
e) Involve other changes in the existing environment which, due to their location or nature, could result in conversion of Farmland, to non-agricultural use or conversion of forest land to non-forest use?	<input type="checkbox"/>	<input type="checkbox"/>	<input type="checkbox"/>	<input checked="" type="checkbox"/>

ENVIRONMENTAL SETTING (BASELINE):

The project site is not located in or near any agricultural or forestry resources. The project site has always been vacant and open space.

REGULATORY SETTING:

Federal Laws, Regulations, and Policies

No federal regulations are applicable to agricultural and forestry resources in relation to the proposed project.

State Laws, Regulations, and Policies

Farmland Mapping and Monitoring Program

The Farmland Mapping and Monitoring Program (FMMP), administered by the California Department of Conservation (CDC), produces maps and statistical data for use in analyzing impacts on California's agricultural resources (DLRP 2022a). The FMMP rates and classifies agricultural land according to soil quality, irrigation status, and other criteria. Important Farmland categories are as follows:

Prime Farmland: Farmland with the best combination of physical and chemical features able to sustain long-term agricultural production. These lands have the soil quality, growing season, and moisture supply needed to produce sustained high yields. Prime Farmland must have been used for irrigated agricultural production at some time during the 4 years before the FMMP's mapping date.

Farmland of Statewide Importance: Farmland similar to Prime Farmland, but with minor shortcomings, such as greater slopes or less ability to store soil moisture. Farmland of Statewide Importance must have been used for irrigated agricultural production at some time during the 4 years before the FMMP's mapping date.

Unique Farmland: Farmland of lesser quality soils used for the production of the state's leading agricultural crops. These lands are usually irrigated but might include non-irrigated orchards or vineyards, as found in some climatic zones. Unique Farmland must have been cropped at some time during the 4 years before the FMMP's mapping date.

Farmland of Local Importance: Land of importance to the local agricultural economy as determined by each county's board of supervisors and a local advisory committee.

California Land Conservation Act of 1965 (Williamson Act)

The California Land Conservation Act of 1965 (commonly referred to as the Williamson Act) allows local governments to enter into contracts with private landowners for the purpose of preventing conversion of agricultural land to non-agricultural uses (DLRP 2022b). In exchange for restricting their property to agricultural or related open space use, landowners who enroll in Williamson Act contracts receive property tax assessments that are substantially lower than the market rate.

Z'berg-Nejedly Forest Practice Act

Logging on private and corporate land in California is regulated by the 1973 Z'berg-Nejedly Forest Practice Act. This Act established the Forest Practice Rules (FPRs) and a politically-appointed Board of Forestry to oversee their implementation. The California Department of Forestry and Fire Protection (CAL FIRE) works under the direction of the Board of Forestry and is the lead government agency responsible for approving logging plans and for enforcing the FPRs.

APPLICABLE THRESHOLDS OF SIGNIFICANCE:

The list of agriculture or forestry resource effects that may be considered significant contained in Appendix G of the CEQA Guidelines (Environmental Checklist) was used to establish a threshold of significance. A substantial adverse effect to Agricultural Resources would occur if:

- There is a conversion of choice agricultural land to nonagricultural use, or impairment of the agricultural productivity of agricultural land;
- The amount of agricultural land in the County is substantially reduced; or
- Agricultural uses are subjected to impacts from adjacent incompatible land uses.

ENVIRONMENTAL STUDIES PERFORMED AND METHODOLOGY:

Based on the lack of agricultural or forestry resources on or near the project site, no environmental studies relating to agriculture or forestry resources were prepared for the project.

IMPACT ANALYSES AND CONCLUSIONS:

- a. **Farmland Mapping and Monitoring Program:** The project site is not zoned for agricultural use or located within an Agricultural District. The Project site is also not designated as farmland of local importance (DLRP 2022). There would be **no impact**.
- b. **Agricultural Uses:** The project site is not located within a Williamson Act Contract, nor is it adjacent to lands under a contract. There would be **no impact**.
- c-d. **Loss of Forest land or Conversion of Forest land:** The project site is not designated as Timberland Preserve Zone (TPZ) or other forestland according to the General Plan and Zoning Ordinance. There would be **no impact** to forest land.
- e. **Conversion of Prime Farmland or Forest Land:** The project site is not located within an agricultural zone district or located on forest land and would not convert farmland or forest land to non-agriculture use. There would be **no impact**.

FINDING: Implementation of the project would not result in the loss of agricultural or forestry land to urban uses and would not impact any existing agricultural land uses from adjacent incompatible uses.

Resources:

California Department of Conservation, Division of Land Resource Protection (DLRP). 2022a. *California Important Farmland Finder*. Available at <https://www.conservation.ca.gov/dlrp/fmmp> (Accessed March 3, 2022).

DLRP. 2022b. *Williamson Act Program Overview*.

https://www.conservation.ca.gov/dlrp/wa/Pages/wa_overview.aspx (Accessed October 25, 2022).

3. AIR QUALITY				
Where available, the significance criteria established by the applicable air quality management district or air pollution control district may be relied upon to make the following determinations.				
Would the project:	Potentially Significant Impact	Less Than Significant with Mitigation	Less Than Significant Impact	No Impact
a) Conflict with or obstruct implementation of the applicable air quality plan?	<input type="checkbox"/>	<input type="checkbox"/>	<input checked="" type="checkbox"/>	<input type="checkbox"/>
b) Result in a cumulatively considerable net increase of any criteria pollutant for which the project region is non-attainment under an applicable federal or state ambient air quality standard?	<input type="checkbox"/>	<input type="checkbox"/>	<input checked="" type="checkbox"/>	<input type="checkbox"/>
c) Expose sensitive receptors to substantial pollutant concentrations?	<input type="checkbox"/>	<input type="checkbox"/>	<input checked="" type="checkbox"/>	<input type="checkbox"/>
d) Result in other emissions (such as those leading to odors) adversely affecting a substantial number of people?	<input type="checkbox"/>	<input type="checkbox"/>	<input checked="" type="checkbox"/>	<input type="checkbox"/>

ENVIRONMENTAL SETTING (BASELINE):

Air quality is defined by the concentration of pollutants related to human health. Ambient concentrations of air pollutants are determined by the rate and location of pollutant emissions from pollution sources, and the regional or local atmosphere's ability to transport and disperse pollutant emissions. Natural factors that affect pollutant transport and dispersion include terrain, wind, atmospheric stability, and sunlight. Therefore, ambient air quality conditions within the local air basin are influenced by such natural factors as topography, meteorology, and climate, in addition to the amount of air pollutant emissions released by existing air pollutant sources.

Cameron Park is located in the foothills of the Sierra Nevada mountain range. The surrounding region is characterized by hills and valleys. The proposed project site is located in the Mountain Counties Air Basin (MCAB). The MCAB lies along the northern Sierra Nevada mountain range, close to or contiguous with the Nevada border, covering an area of approximately 11,000 square miles. Elevations in El Dorado County range from over 10,000 feet at the Sierra crest down to several hundred feet above sea level at the County's boundary with Sacramento County. Topography is highly variable throughout El Dorado County and includes rugged mountain peaks and valleys with extreme slopes and elevation variations in the Sierra range, as well as rolling foothills to the west. The general climate of the MCAB varies considerably with elevation and proximity to the Sierra range. The terrain features of the MCAB allow for several climates to exist in relative proximity. The terrain of mountains and hills results in a wide variation in rainfall, temperature, and localized winds throughout the MCAB. Temperature variations have an important influence on basin wind flow, dispersion along mountain ridges, vertical air mixing, and photochemistry.

The project area usually has warm to hot summers and cool, wet winters. The Sierra Nevada range receives large amounts of precipitation from storms moving inland from the Pacific Ocean in the winter, with lesser amounts from intermittent "Monsoonal" moisture flows from the south and cumulus buildup in the summer. Precipitation amounts are high in the highest mountain elevations but decline rapidly toward the western portion of the MCAB. Winter temperatures in the mountains can be below freezing for weeks at a time, and substantial amounts of snow can accumulate, but in the western foothills, winter temperatures usually drop below freezing only at night and

precipitation is mixed as rain or light snow. In the summer, temperatures in the mountains are mild, with daytime highs in the 70s to low 80s degrees Fahrenheit (°F), but the western end of the County can routinely exceed 100 °F. From an air quality perspective, the topography and meteorology of the MCAB combine such that local conditions are the predominate factor in determining the effect of emissions in the MCAB.

REGULATORY SETTING:

Federal Laws, Regulations, and Policies

The Clean Air Act is implemented by the U.S. Environmental Protection Agency (USEPA) and sets ambient air limits, the National Ambient Air Quality Standards (NAAQS), for six criteria pollutants: particulate matter of aerodynamic radius of 10 micrometers or less (PM₁₀), particulate matter of aerodynamic radius of 2.5 micrometers or less (PM_{2.5}), carbon monoxide (CO), nitrogen dioxide (NO₂), ground-level ozone, and lead. Of these criteria pollutants, particulate matter and ground-level ozone pose the greatest threats to human health.

State Laws, Regulations, and Policies

The California Air Resources Board (CARB) sets standards for criteria pollutants in California that are more stringent than the NAAQS and include the following additional contaminants: visibility-reducing particles, hydrogen sulfide, sulfates, and vinyl chloride. The proposed project site is located within the MCAB, which is comprised of seven air districts: the Northern Sierra Air Quality Management District, Placer County Air Pollution Control District, Amador County Air Pollution Control District, Calaveras County Air Pollution Control District, Tuolumne County Air Pollution Control District, Mariposa County Air Pollution Control District, and a portion of the El Dorado County Air Quality Management District, which consists of the western portion of El Dorado County. The El Dorado County Air Quality Management District (AQMD) manages air quality for attainment and permitting purposes within the west slope portion of El Dorado County.

USEPA and CARB regulate various stationary sources, area sources, and mobile sources. USEPA has regulations involving performance standards for specific sources that may release toxic air contaminants (TACs), known as hazardous air pollutants (HAPs) at the federal level. In addition, USEPA has regulations involving emission criteria for off-road sources such as emergency generators, construction equipment, and vehicles. CARB is responsible for setting emission standards for vehicles sold in California and for other emission sources, such as consumer products and certain off-road equipment. CARB also establishes passenger vehicle fuel specifications.

Air quality in the project area is regulated by the El Dorado County AQMD. California Air Resources Board and local air districts are responsible for overseeing stationary source emissions, approving permits, maintaining emissions inventories, maintaining air quality stations, overseeing agricultural burning permits, and reviewing air quality-related sections of environmental documents required to comply with CEQA. The AQMD regulates air quality through the federal and state Clean Air Acts, district rules, and its permit authority. National and state ambient air quality standards have been adopted by the USEPA and State of California, respectively, for each criteria pollutant: ozone, particulate matter, carbon monoxide, nitrogen dioxide, and sulfur dioxide (SO₂).

The USEPA and State also designate regions as “attainment” (within standards) or “nonattainment” (exceeds standards) based on the ambient air quality. The County is in nonattainment status for ozone standards (federal and state) and PM₁₀ standard (state).

Naturally occurring asbestos (NOA) is also a concern in El Dorado County because it is known to be present in certain soils and can pose a health risk if released into the air. The AQMD has adopted an El Dorado County Naturally Occurring Asbestos Review Area Map that identifies those areas more likely to contain NOA. The proposed project site is not located in an area found to contain NOA (El Dorado County 2018).

APPLICABLE THRESHOLDS OF SIGNIFICANCE:

The El Dorado County AQMD adopted CEQA thresholds of significance for development projects in the El Dorado County AQMD’s *Guide to Air Quality Assessment* (February 2002). The Guide includes quantitative thresholds for

Reactive Organic Gasses (ROG) and NO_x. For the other pollutants, significance is based on the potential to exceed ambient air quality standards. The significance thresholds to define substantial contribution for both operational and construction emissions are presented in the table below.

Criteria Pollutant	El Dorado County AQMD Threshold	
Reactive Organic Gases (ROG)	82 lbs/day	
Nitrogen Oxides (NO _x)	82 lbs/day	
Carbon Monoxide (CO)	8-hour average: 9 ppm	1-hour average: 20 ppm
NO ₂	Annual: 0.03 ppm	1-hour average: 0.18 ppm
Particulate Matter (PM ₁₀):	Annual: 1 µg/m ³	24-hour average: 5 µg/m ³
Particulate Matter (PM _{2.5}):	Annual: 0.3 µg/m ³	24-hour average: 1.2 µg/m ³
Ozone	8-hour average: 0.12 ppm	1-hour average: .09

Lbs/day = pounds per day
ppm = parts per million
ug/m³ = micrograms per cubic meter of air

According to the El Dorado County AQMD Guide, a substantial adverse effect on air quality would occur if:

- Emissions of ROG and NO_x will result in construction or operation emissions greater than 82 lbs/day;
- Emissions of PM₁₀, CO, SO₂ and NO_x, as a result of construction or operation emissions, will result in ambient pollutant concentrations in excess of the applicable National or State Ambient Air Quality Standard; or
- Emissions of toxic air contaminants cause cancer risk greater than 1 in 1 million (10 in 1 million if best available control technology for toxics is used) or a non-cancer Hazard Index greater than 1. In addition, the project must demonstrate compliance with all applicable District, State and U.S. EPA regulations governing toxic and hazardous emissions.

ENVIRONMENTAL STUDIES PERFORMED AND METHODOLOGY:

Based on review of the project by the El Dorado County AQMD, the project was determined to not cause a significant air quality impact. Therefore, project-specific environmental studies relating to air quality were not prepared.

IMPACT ANALYSES AND CONCLUSIONS:

- a. **Air Quality Plan, Air Quality Standards:** Regional air quality impacts and attainment of standards are the result of the cumulative impacts of all emission sources within the air basin. Individual projects are generally not large enough to contribute measurably to an existing violation of air quality standards. Therefore, the cumulative impact of the proposed project is based on its cumulative contribution. If project-generated emissions of either of the ozone precursor pollutants (ROG and NO_x) would exceed the AQMD’s quantitative significance thresholds, then the project would be considered to contribute to violations of the applicable standards and conflict with the attainment plans. However, proposed project emissions would not exceed the AQMD’s quantitative thresholds for ROG and NO_x and would not produce a localized exceedance of any other criteria pollutant.

The AQMD CEQA Guide indicates that a significant impact would occur if the proposed project is located in a jurisdiction that does not implement the emission reduction measures contained in and/or derived from an applicable Air Quality Attainment Plan (AQAP). The AQAP strategy relies on the many existing federal, state, and local control programs to achieve reductions of ozone precursors. The California Air Resources Board (ARB) and the Sacramento Federal Nonattainment Area (SFNA) air districts, including AQMD, will continue to enforce existing strategies and implement transportation control measures (TCMs). Residents of the proposed duplexes can take advantage of the adopted TCMs that encourage ridesharing, transit use, and bicycling. The Spare the Air program provides public education to reduce emissions during ozone episodes and general awareness of air quality during the rest of the year. El Dorado Transit provides local transit service and connections to regional transit systems that would be available to residents. Route 40 provides hourly service between Cameron Park and Shingle Springs and transfers to the 50 Express and Sacramento Commuter. Therefore, the community of Cameron Park is implementing TCMs required by the AQAP.

The proposed project would also comply with rules that apply to construction activities. Specifically, the project would be required to comply with the fugitive dust controls contained in AQMD Rule 223-1—Fugitive Dust Emissions. In addition, the proposed project would not exceed any quantitative emission threshold indicating that the project would not make a cumulatively considerable contribution to a new or existing violation of an air quality standard. Therefore, the proposed project would not conflict with measures designed to reduce operational emissions.

Overall, the proposed project would not result in an increase in the frequency or severity of existing air quality violations, cause or contribute to new violations, or delay timely attainment of air quality standards or the interim emission reductions specified in the air quality plans. For these reasons, the proposed project would result in a **less-than-significant** impact.

- b. **Air Quality Standards and Cumulative Impacts:** Air pollutant emissions have both regional and localized effects. This analysis assesses the regional effects of the project's criteria pollutant emissions in comparison to the AQMD thresholds of significance for short-term construction activities and long-term operational emissions associated with implementing the project.

According to AQMD, the primary pollutants of concern during project construction include ROG, CO, NO_x, SO_x, and PM₁₀. Ozone is a secondary pollutant that can be formed miles from the source of emissions, through reactions of ROG and NO_x emissions in the presence of sunlight. Therefore, ROG and NO_x are termed ozone precursors. The monitoring stations nearest to the proposed project site occasionally exceed the state and national ozone standards. Therefore, if the project emits a substantial quantity of ozone precursors, the project may contribute to an exceedance of the ozone standard. The AQMD CEQA Guide includes emission-based thresholds of 82 pounds per day for ROG and NO_x, and it uses concentration-based thresholds for CO and PM₁₀ because the impacts are more localized for these pollutants.

The proposed project would not contain sources that would produce substantial quantities of SO₂ emissions during construction and operation. Therefore, no further analysis of SO₂ is required.

Construction Emissions

Construction emissions associated with implementing the project were calculated using CalEEMod version 2022 and would generate a maximum daily emission of 1.4 pound per day (lbs/day) of ROG and 14.0 lbs/day of NO_x. The CalEEMod output calculations are provided in Attachment 1. Both of these calculated emissions would be below the significance thresholds (82 lbs/day). Therefore, construction air emissions are considered to be **less than significant**.

Operational Emissions

The AQMD reviewed the proposed project and made a determination that the creation of ten lots for future residential development would be below the size of projects identified as resulting in potentially significant ROG and NO_x operation emissions. Therefore, an Air Quality Analysis is not required for project operations and operational air emissions are considered to be **less than significant**.

- c. **Sensitive Receptors:** The CEQA Guidelines identify sensitive receptors as facilities that house or attract children, the elderly, people with illnesses, or others that are especially sensitive to the effects of air pollutants. Hospitals, schools, and convalescent hospitals are examples of sensitive receptors. The closest sensitive receptors to the proposed project site include existing residences adjacent to the south and Camerado Springs Middle School to the west of the site. Additional residences are located within a quarter-mile to the north and northeast of the proposed project site.

Carbon Monoxide Hotspot Analysis

The potential to violate CO standards is a localized impact based on the potential to expose sensitive receptors to unhealthy CO concentrations. All of California, including the MCAB, is classified as attainment for state and federal CO standards and CO is no longer monitored in the area. CO emissions from motor vehicles have been reduced to the extent that CO levels that violate the air quality standards are not an issue of concern except for areas with extremely high levels of traffic congestion.

Localized high levels of CO are associated with traffic congestion and idling or slow-moving vehicles. The proposed project would result in a small increase in vehicles trips during construction activities and project operation. The AQMD CEQA Guide includes a screening methodology based on peak-hour trips generated by the project to determine if more detailed CO hotspot modeling should be performed. Based on comments from the El Dorado County Department of Transportation, the project is expected to generate 11 peak hour trips. The AQMD CEQA Guide indicates that 100 peak-hour trips would produce a project-related CO concentration of 0.4 ppm. Using this ratio, peak hour trips generated by the proposed project would result in a CO concentration of 0.04 ppm (11/100 x 0.4). The Folsom area currently has an 8-hour CO concentration of 3.0 ppm. Adding the proposed project 0.03 ppm to the 3.0 ppm 8-hour concentration for Folsom would result in 3.04 ppm which is below 9.0 ppm standard and would not result in the potential for creating a carbon monoxide hotspot. The temporary and small addition of construction related vehicle trips would also not increase congestion to levels that would have the potential to create a CO hotspot. **No impact** related to CO hotspot would occur.

PM₁₀ Analysis

According to the El Dorado County AQMD CEQA Guide, mass emissions of fugitive dust PM₁₀ need not be quantified, and may be assumed to be not significant, if the project implements dust control measures to prevent visible dust at the property line. The proposed project would be required to comply with El Dorado County AQMD Rule 223-1 Fugitive Dust—Construction, Bulk Material Handling, Blasting, and other Earth Moving Activities. The rule includes a list of best management practices (BMPs) that would ensure that fugitive dust impacts remain at a less-than-significant level. Examples of BMPs identified in the rule include limiting the speed of vehicles traveling within construction sites, watering soils, and/or using tarps or other suitable enclosures on haul trucks. In addition, the AQMD requires projects to prepare Dust Control Plans to ensure appropriate BMPs are implemented. The Dust Control Plan prepared for the proposed project would require implementation of applicable BMPs during construction activities. Therefore, potential impacts from fugitive dust PM₁₀ would be **less than significant**.

Naturally Occurring Asbestos

El Dorado County has a substantial number of areas where naturally occurring asbestos is known to occur. El Dorado County issued a map displaying the areas of the County identified as Asbestos Review Areas. Review of the map indicates that the project site is not located in an area found to contain NOA and development of the project site is not anticipated to expose receptors to naturally occurring asbestos (El Dorado County 2018). However, a letter from the El Dorado County AQMD identified that future development of the site would require a Naturally-Occurring Asbestos Dust Mitigation Plan (ADMP) if more than 20 cubic yards of dirt would be moved. In addition, standard conditions could apply at the time of development and would be placed on the proposed project at the discretion of the El Dorado County AQMD. The proposed project would be anticipated to move more than 20 cubic yards of dirt during construction activities and, therefore, would be required to prepare and implement an ADMP. With the project's implementation of the required ADMP, at the discretion of the El Dorado County AQMD, impacts related to naturally occurring asbestos would remain at a **less-than-significant** level.

Construction: Toxic Air Contaminants

Most emissions from construction activities occur during the grading and site preparation phases that would occur over the first two months of construction and would not overlap with project operations. Limited amounts of diesel equipment would be used during ground-up construction of the proposed duplexes which would occur

during the majority of the construction schedule. However, air emissions from construction equipment would be temporary and short in duration. Based on the short duration of construction activities and the AQMD CEQA Guide, no additional TAC analysis is required and potential impacts would be considered **less than significant**.

Operation: Toxic Air Contaminants

The AQMD CEQA Guide indicates that projects generating less than 10 diesel truck trips per day would not result in significant impacts from TAC emissions. Based on truck trip survey data from similar projects, residential developments generate less than 2 diesel truck trips per day. The project would result in **less than significant** impacts from TAC emissions because operations are anticipated to generate less than 10 diesel truck trips per day.

The project was also assessed for potential impacts related to TAC emissions from existing sources of TAC emissions on the project site. In the California Building Industry Association v. Bay Area Air Quality Management District, 62 Cal.4th 369 (2015) (Case No. S213478) the California Supreme Court held that “agencies subject to CEQA generally are not required to analyze the impact of existing environmental conditions on a projects’ future users or residents. But when a proposed project risks exacerbating those environmental hazards or conditions that already exist, an agency must analyze the potential impact of such hazards on future residents or users. In those specific instances, it is the project’s impact on the environment—and not the environment’s impact on the project—that compels an evaluation of how future residents or users could be affected by exacerbated conditions.” Although the Court ruled that impacts from the existing environment on projects are not required to be addressed under CEQA, land uses such as gasoline stations, dry cleaners, distribution centers, and auto body shops can expose residents to high levels of TAC emissions if they are in proximity of the project site. Information regarding the location of existing TAC sources is provided for disclosure purposes only and not as a measure of the project’s significance under CEQA. The nearest gasoline station is approximately 0.15 mile southeast of the project site. The nearest dry cleaner is approximately 0.15 mile east of the project site. The nearest auto body shop is about 1.6 miles east of the site. The project is approximately ¼-mile north of State Route 50. At these distances, no significant exposure of potential future residences at the project site to TAC emissions would occur. In addition, implementation of the proposed land uses would not create a significant source of TAC emissions. For these reasons, this potential impact is considered to be **less than significant**.

- d. **Objectionable Odors:** Odor impacts on residential areas and other sensitive receptors (e.g., hospitals, day-care centers, schools) warrant the closest scrutiny, but consideration should also be given to other land uses where people may congregate such as recreational facilities, worksites, and commercial areas. Land uses that are typically identified as sources of objectionable odors include landfills, transfer stations, sewage treatment plants, wastewater pump stations, composting facilities, feed lots, coffee roasters, asphalt batch plants, and rendering plants. The proposed project would not result in developing any of these types of activities. Therefore, the proposed project would not be considered a generator of objectionable odors during operations. During construction, diesel-powered vehicles and equipment used on-site would create localized odors. These odors would be temporary and would not likely be noticeable for extended periods of time beyond the project’s site boundaries. The potential for diesel odor impacts is, therefore, considered **less than significant**.

FINDING: The proposed project would not affect the implementation of regional air quality regulations or management plans. The proposed project would not be anticipated to cause substantial adverse effects to air quality, nor exceed established significance thresholds for air quality impacts.

Resources:

El Dorado County, 2018. *Asbestos Review Areas, Western Slope County of El Dorado*. Available at: https://www.edcgov.us/Government/AirQualityManagement/Pages/asbestos_maps.aspx (Accessed February 1, 2022).

El Dorado County Air Quality Management District, 2002. *Guide to Air Quality Assessment*. Available at: https://www.edcgov.us/Government/AirQualityManagement/Pages/guide_to_air_quality_assessment.aspx (Accessed December 24, 2022).

4. BIOLOGICAL RESOURCES				
Would the project:	Potentially Significant Impact	Less Than Significant with Mitigation	Less Than Significant Impact	No Impact
a) Have a substantial adverse effect, either directly or through habitat modifications, on any species identified as a candidate, sensitive, or special status species in local or regional plans, policies, or regulations, or by the California Department of Fish and Wildlife, U.S. Fish and Wildlife Service, or NOAA Fisheries?	<input type="checkbox"/>	<input checked="" type="checkbox"/>	<input type="checkbox"/>	<input type="checkbox"/>
b) Have a substantial adverse effect on any riparian habitat or other sensitive natural community identified in local or regional plans, policies, regulations or by the California Department of Fish and Wildlife or U.S. Fish and Wildlife Service?	<input type="checkbox"/>	<input type="checkbox"/>	<input checked="" type="checkbox"/>	<input type="checkbox"/>
c) Have a substantial adverse effect on state or federally protected wetlands (including, but not limited to, marsh, vernal pool, coastal, etc.) through direct removal, filling, hydrological interruption, or other means?	<input type="checkbox"/>	<input type="checkbox"/>	<input checked="" type="checkbox"/>	<input type="checkbox"/>
d) Interfere substantially with the movement of any native resident or migratory fish or wildlife species or with established native resident or migratory wildlife corridors, or impede the use of native wildlife nursery sites?	<input type="checkbox"/>	<input type="checkbox"/>	<input checked="" type="checkbox"/>	<input type="checkbox"/>
e) Conflict with any local policies or ordinances protecting biological resources, such as a tree preservation policy or ordinance?	<input type="checkbox"/>	<input type="checkbox"/>	<input checked="" type="checkbox"/>	<input type="checkbox"/>
f) Conflict with the provisions of an adopted Habitat Conservation Plan, Natural Community Conservation Plan, or other approved local, regional, or state habitat conservation plan?	<input type="checkbox"/>	<input type="checkbox"/>	<input type="checkbox"/>	<input checked="" type="checkbox"/>

ENVIRONMENTAL SETTING (BASELINE):

The project site’s biological resources are primarily defined by remnant oak woodlands and non-native annual grassland.

REGULATORY SETTING:

Federal Laws, Regulations, and Policies

Endangered Species Act

The Endangered Species Act (ESA) (16 U.S. Code [USC] Section 1531 *et seq.*; 50 Code of Federal Regulations [CFR] Parts 17 and 222) provides for conservation of species that are endangered or threatened throughout all or a substantial

portion of their range, as well as protection of the habitats on which they depend. The U.S. Fish and Wildlife Service (USFWS) and the National Marine Fisheries Service (NMFS) share responsibility for implementing the ESA. In general, USFWS manages terrestrial and freshwater species, whereas NMFS manages marine and anadromous species.

Section 9 of the ESA and its implementing regulations prohibit the "take" of any fish or wildlife species listed under the ESA as endangered or threatened, unless otherwise authorized by federal regulations. The ESA defines the term "take" to mean "harass, harm, pursue, hunt, shoot, wound, kill, trap, capture, or collect, or to attempt to engage in any such conduct" (16 USC Section 1532). Section 7 of the ESA (16 USC Section 1531 *et seq.*) outlines the procedures for federal interagency cooperation to conserve federally listed species and designated critical habitats. Section 10(a)(1)(B) of the ESA provides a process by which nonfederal entities may obtain an incidental take permit from USFWS or NMFS for otherwise lawful activities that incidentally may result in "take" of endangered or threatened species, subject to specific conditions.

Migratory Bird Treaty Act

The Migratory Bird Treaty Act (MBTA) (16 USC, Chapter 7, Subchapter II) protects migratory birds. Most actions that result in take, or the permanent or temporary possession of, a migratory bird constitute violations of the MBTA. The MBTA also prohibits destruction of occupied nests. USFWS is responsible for overseeing compliance with the MBTA.

Bald and Golden Eagle Protection Act

The federal Bald and Golden Eagle Protection Act (16 U.S.C. 668-668c), first enacted in 1940, prohibits "taking" bald eagles, including their parts, nests, or eggs. The Act provides criminal penalties for persons who "take, possess, sell, purchase, barter, offer to sell, purchase or barter, transport, export or import, at any time or any manner, any bald eagle ... [or any golden eagle], alive or dead, or any part, nest, or egg thereof." The Act defines "take" as "pursue, shoot, shoot at, poison, wound, kill, capture, trap, collect, molest or disturb." The definition for "Disturb" includes injury to an eagle, a decrease in its productivity, or nest abandonment, by substantially interfering with normal breeding, feeding, or sheltering behavior. In addition to immediate impacts, this definition also covers impacts that result from human-induced alterations initiated around a previously used nest site during a time when eagles are not present.

Clean Water Act

Clean Water Act (CWA) section 404 regulates the discharge of dredged and fill materials into waters of the U.S., which include all navigable waters, their tributaries, and some isolated waters, as well as some wetlands adjacent to the aforementioned waters (33 CFR Section 328.3). Areas typically not considered to be jurisdictional waters include non-tidal drainage and irrigation ditches excavated on dry land, artificially irrigated areas, artificial lakes or ponds used for irrigation or stock watering, small artificial waterbodies such as swimming pools, and water-filled depressions (33 CFR Part 328). Areas meeting the regulatory definition of waters of the U.S. are subject to the jurisdiction of U.S. Army Corps of Engineers (USACE) under the provisions of CWA Section 404. Construction activities involving placement of fill into jurisdictional waters of the U.S. are regulated by USACE through permit requirements. No USACE permit is effective in the absence of state water quality certification pursuant to Section 401 of CWA.

Section 401 of the CWA requires an evaluation of water quality when a proposed activity requiring a federal license or permit could result in a discharge to waters of the U.S. In California, the State Water Resources Control Board (SWRCB) and its nine Regional Water Quality Control Boards (RWQCBs) issue water quality certifications. Each RWQCB is responsible for implementing Section 401 in compliance with the CWA and its water quality control plan (also known as a Basin Plan). Applicants for a federal license or permit to conduct activities that may result in the discharge to waters of the U.S. (including wetlands or vernal pools) must also obtain a Section 401 water quality certification to ensure that any such discharge will comply with the applicable provisions of the CWA.

State Laws, Regulations, and Policies

California Fish and Game Code

The California Fish and Game Code includes various statutes that protect biological resources, including the Native Plant Protection Act of 1977 (NPPA) and the California Endangered Species Act (CESA). The NPPA (California Fish and Game Code Section 1900-1913) authorizes the Fish and Game Commission to designate plants as endangered or rare and prohibits take of any such plants, except as authorized in limited circumstances.

CESA (California Fish and Game Code Section 2050–2098) prohibits state agencies from approving a project that would jeopardize the continued existence of a species listed under CESA as endangered or threatened. Section 2080 of the California Fish and Game Code prohibits the take of any species that is state listed as endangered, threatened, or designated as a candidate for such listing. California Department of Fish and Wildlife (CDFW) may issue an incidental take permit authorizing the take of listed and candidate species if that take is incidental to an otherwise lawful activity, subject to specified conditions.

California Fish and Game Code Section 3503, 3513, and 3800 protect native and migratory birds, including their active or inactive nests and eggs, from all forms of take. In addition, Section 3511, 4700, 5050, and 5515 identify species that are fully protected from all forms of take. Section 3511 lists fully protected birds, Section 5515 lists fully protected fish, Section 4700 lists fully protected mammals, and Section 5050 lists fully protected amphibians.

Streambed Alteration Agreement

Sections 1601 to 1606 of the California Fish and Game Code require that a Streambed Alteration Application be submitted to CDFW for any activity that may substantially divert or obstruct the natural flow or substantially change the bed, channel, or bank of any river, stream, or lake. As a general rule, this requirement applies to any work undertaken within the 100-year floodplain of a stream or river containing fish or wildlife resources.

California Native Plant Protection Act

The California Native Plant Protection Act (California Fish and Game Code Section 1900–1913) prohibits the taking, possessing, or sale of any plants with a state designation of rare, threatened, or endangered (as defined by CDFW). The California Native Plant Society (CNPS) maintains a list of plant species native to California that has low population numbers, limited distribution, or are otherwise threatened with extinction. This information is published in the Inventory of Rare and Endangered Plants of California. Potential impacts to populations of CNPS-listed plants receive consideration under CEQA review.

Forest Practice Act

Logging on private and corporate land in California is regulated by the Z'berg-Nejedly Forest Practices Act (FPA), which took effect January 1, 1974. The act established the Forest Practice Rules (FPRs) and a politically-appointed Board of Forestry to oversee their implementation. CAL FIRE works under the direction of the Board of Forestry and is the lead government agency responsible for approving logging plans and for enforcing the FPRs. A Timber Harvest Plan (THP) must be prepared by a Registered Professional Forester (RPF) for timber harvest on virtually all non-federal land. The FPA also established the requirement that all non-federal forests cut in the State be regenerated with at least three hundred stems per acre on high site lands, and one hundred fifty trees per acre on low site lands.

Local Laws, Regulations, and Policies

The County General Plan also includes policies that contain specific, enforceable requirements and/or restrictions and corresponding performance standards that address potential impacts on special-status plant species or create opportunities for habitat improvement. The El Dorado County General Plan designates the Important Biological Corridor (IBC) (El Dorado County 2019). Lands located within the overlay district are subject to the following provisions, given that they do not interfere with agricultural practices:

- Increased minimum parcel size;
- Higher canopy-retention standards and/or different mitigation standards/thresholds for oak woodlands;
- Lower thresholds for grading permits;
- Higher wetlands/riparian retention standards and/or more stringent mitigation requirements for wetland/riparian habitat loss;
- Increased riparian corridor and wetland setbacks;
- Greater protection for rare plants (e.g., no disturbance at all or disturbance only as recommended by U.S. Fish and Wildlife Service/California Department of Fish and Wildlife);
- Standards for retention of contiguous areas/large expanses of other (non-oak or non-sensitive) plant communities;
- Building permits discretionary or some other type of “site review” to ensure that canopy is retained;
- More stringent standards for lot coverage, floor area ratio (FAR), and building height; and
- No hindrances to wildlife movement (e.g., no fences that would restrict wildlife movement).

APPLICABLE THRESHOLDS OF SIGNIFICANCE:

The list of biological resource effects that may be considered significant contained in Appendix G of the CEQA Guidelines (Environmental Checklist) was used to establish a threshold of significance.

ENVIRONMENTAL STUDIES PERFORMED AND METHODOLOGY:

A site-specific biological resources evaluation (BRE) was prepared in 2021 which discusses conditions found at the proposed project site. The BRE is provided in Attachment 3. In addition, a site-specific arborist report was prepared in 2021 which discusses oak woodland resources found at the project site. The arborist report is provided in Attachment 2. The BRE and arborist report considered a substantial adverse effect on biological resources would occur if the implementation of the project would:

- Substantially reduce or diminish habitat for native fish, wildlife or plants;
- Cause a fish or wildlife population to drop below self-sustaining levels;
- Threaten to eliminate a native plant or animal community;
- Reduce the number or restrict the range of a rare or endangered plant or animal;
- Substantially affect a rare or endangered species of animal or plant or the habitat of the species; or
- Interfere substantially with the movement of any resident or migratory fish or wildlife species.

IMPACT ANALYSES AND CONCLUSIONS:

- a. **Special Status Species:** A site-specific BRE was prepared in 2021 which discusses conditions found at the project site. This evaluation of biological resources was conducted to determine if any special-status plant or wildlife species, their habitats, or sensitive habitats occurred on the proposed project site. Data on known special-status species and habitats in the project area were obtained from state and federal agencies including USFWS, California Natural Diversity Database (CNDDDB), and California Native Plant Society (CNPS)). A field survey was conducted in 2021 to determine what habitat types were present. The field survey, map review, and a review of the biology of evaluated species and habitats were used to determine the special-status species and sensitive habitats that could occur on the project site. The entire site was walked and searched for the presence of special-status species or sensitive natural communities, including the potential presence of wetlands or other waters of the United States. Plant and animal species observed on the project site that were identifiable at the time of the biological reconnaissance were documented.

The proposed project site contains one habitat type: non-native annual grassland. The site is vegetated primarily with non-native grasses and forbs typical of disturbed sites within largely developed areas. The dominant species within the non-native annual grassland are non-native grasses including wild oat, soft chess, barley, medusa head, ripgut brome, fescue, and silver European hairgrass. Common forbs included doveweed, rose clover, prickly lettuce, and tarweed. Some large blue oaks occur along the western side of the proposed project site and there are

some scattered small coyote bush. Overall, the proposed project site is primarily vegetated with ruderal herbaceous species.

The proposed project site is located within an urban area and is surrounded by development. Wildlife use of the site would be expected to be limited to common species adapted to disturbed areas. No wildlife was observed on the project site during the biological reconnaissance; however, there were several ground squirrel burrows identified on the project site.

No special-status plant species were observed in the proposed project site during the biological reconnaissance survey. Based on the evaluation of the potential for special-status plant species to occur in the proposed project site that is described above, there are no special-status plant species with the potential to occur on the project site. The proposed project site does not provide suitable soils or habitat for special-status plant species. No impacts to special-status plant species would be expected to occur as a result from implementing the proposed project.

No special-status animal species were observed in the proposed project site during the biological reconnaissance survey. Based on the evaluation of the potential for special-status animal species to occur in the proposed project site, there are no special-status animal species with the potential to occur on the project site. The majority of the regionally-occurring special-status animal species require aquatic habitats such as vernal pools, seasonal wetlands, ponds, marshes, and riverine habitats. The remaining species occur in large tracts of undeveloped lands such as open grasslands or forested habitats. There are no aquatic habitats on or adjacent to the proposed project site and the site is small and surrounded by development. No impacts to special-status animal species would be expected to occur as a result from implementing the proposed project.

No bird nests were observed on the proposed project site during the biological reconnaissance survey. However, nesting habitat for common raptors, migratory birds and other nesting birds is present in the oak trees in and adjacent to the project site. Common raptor species such as red-tailed hawk and red-shouldered hawk could nest in oak trees in or adjacent to the site. Common bird species could also nest in herbaceous vegetation or on the ground such as mourning dove, killdeer, or a variety of other songbirds. If project activities were to commence during the typical bird nesting season (February 1st to August 31st), project activities in the vicinity of bird nests could lead to abandonment of eggs or young or forced fledging, which would be a violation of Fish and Game Code and considered a significant impact. Because the proposed project site provides potential nesting habitat for common raptors, migratory birds and other nesting birds, impacts to special status species could be potentially significant. The mitigation measure below will be incorporated into the project and reduce the impact to **less than significant with mitigation**.

Mitigation Measure for Nesting Birds:

Mitigation Measure BIO-1

Impacts to nesting bird habitat in the project area will be minimized by implementing the following measures:

- Any vegetation clearing or ground disturbing activities within the Study Area shall take place outside of the typical avian nesting season (e.g., February 1st through August 31st), if feasible. If construction needs to commence between February 1st and August 31st, a pre-construction survey for nesting birds shall be conducted within 500 feet of active construction areas within 14 days prior to commencement of construction. If a lapse in project activity occurs for 14 days or more during the bird nesting season, then the nesting bird surveys shall be re-conducted. If no nesting birds are observed, no further mitigation is required.
- If active bird nests are observed during the pre-construction survey, a buffer zone shall be established around the nest tree(s) until the young have fledged or are no longer dependent on the nest, as determined by a qualified biologist. The radius of the required buffer zone may vary depending on the species, (i.e., 25-100 feet for passerines and 200-300 feet for common raptors), with the dimensions of any required buffer zones to be determined by a qualified biologist. Buffer zones could be reduced if the nest is monitored by a qualified biologist.

- The buffer zone around a nesting tree shall be demarcated with high visibility orange construction fencing (or similar highly visible material) and no construction activities or personnel shall be allowed within the buffer zone.

Timing/Implementation: The developer/ applicant shall be responsible for ensuring implementation of Mitigation Measure BIO-1. If a pre-construction survey is required (per the circumstances described in Mitigation Measure BIO-1), County Planning Services shall verify the completion of the survey within 14 days prior to issuance of any grading permit. If overall site grading would occur for implementation of improvements and/or infrastructure, and grading permits are processed through the County Department of Transportation (DOT), DOT shall verify the completion of survey within 14 days of issuance of any grading permit.

This mitigation measure shall be noted on the Final Map and be included in a Notice of Restriction that shall be recorded for the project site at the time of recordation of the Final Map and all future grading and residential construction plans.

Enforcement/Monitoring: El Dorado County Planning and Building Department and/or County Department of Transportation.

- b. **Riparian Habitat:** Riparian habitats are often considered sensitive natural communities and are also regulated under Section 1600 of the Fish and Game Code. Plant communities are considered sensitive biological resources if they have limited distributions, have high wildlife value, include sensitive species, and/or are particularly susceptible to disturbance. CDFW ranks sensitive communities as "threatened" or "very threatened" and keeps records of their occurrences in CNDDDB. CNDDDB vegetation alliances are ranked 1 through 5, with those alliances ranked globally (G) or statewide (S) as 1 through 3 considered sensitive. Some alliances with the rank of 4 and 5 have "Shingle Springs, CA" USGS quads. While the project site is located in the El Dorado County Rare Plant Mitigation Area 2, the only plant habitat type present on the proposed project site is non-native annual grassland, which is not considered a sensitive natural community. Therefore, **impacts are less than significant** to sensitive natural communities would occur as a result of the proposed project.
- c. **Wetlands:** The U.S. Fish and Wildlife Service's National Wetlands Inventory (NWI) online database was reviewed to determine if there are any wetlands or other waters of the United States mapped by the USFWS in the Study Area. A review of Google Earth historic aerial imagery was also conducted to search for any evidence of wetlands on the site.

During the biological reconnaissance survey, the proposed project site was searched for areas that could potentially qualify as wetlands by containing a predominance of hydrophytic vegetation, hydric soils, and wetland hydrology according to the Corps of Engineers Wetlands Delineation Manual and the Regional Supplement to the Corps of Engineers Wetland Delineation Manual: Arid West Region (Version 2.0). No potential wetlands or other aquatic resources were observed on the site during the biological reconnaissance survey and no evidence of potential wetlands or other aquatic resources was identified on the proposed project site during a search of the NWI database or the review of historic aerial imagery. Therefore, **no impacts** to wetlands or other aquatic resources would occur as a result of implementing the proposed project.

- d. **Migration Corridors:** Wildlife movement corridors, or habitat linkages, are connections between patches of habitat, generally native vegetation, which join two or more larger areas of similar wildlife habitat and allows for physical and genetic exchange between animal populations that could otherwise be isolated. Habitat linkages are typically contiguous strips of natural areas such as riparian corridors, oak woodlands, or drainages. Wildlife movement corridors are critical for the maintenance of ecological processes including facilitating the movement of animals and the continuation of viable populations. Movement corridors may serve to provide a more local linkage such as between foraging and denning areas, or they may be regional in nature providing larger scale migration corridors such as between wintering and summering habitat. Habitat linkages may also serve to allow animals to periodically move away from an area and then

subsequently return. Other corridors may be important as dispersal corridors for young animals. A group of habitat linkages in an area can form a wildlife corridor network.

The site-specific BRE reviewed proposed project site in relation to mapping conducted by the California Essential Habitat Connectivity Project. The California Essential Habitat Connectivity Project goal is to identify large remaining blocks of intact habitat or natural landscape and model linkages between them that need to be maintained, particularly as corridors for wildlife. The proposed project site is not included in any wildlife movement or connectivity corridors mapped by the California Essential Habitat Connectivity Project and does not provide any unique movement or dispersal habitat relative to surrounding lands. The proposed project site is also not located within a Natural Landscape Block (defined as relatively natural habitat blocks that support native biodiversity). Therefore, the proposed project would have **no impact** any wildlife movement corridors.

- e. **Local Policies:** Local policies to protect biological resources include the Important Biological Corridor (IBC) overlay, oak woodland preservation, rare plants and special-status species, and wetland preservation, all with the goal to preserve and protect sensitive natural resources within El Dorado County.

An arborist report for oak woodland resources was prepared in compliance with the El Dorado County General Plan Amendment approved in October 2017 and the County's Oak Resources Management Plan (ORMP) and the Oak Resources Conservation Ordinance. The purpose of the arborist report was to determine the oak woodland area on the proposed project site, identify all native oak trees in the woodland area 24 inches in diameter and greater, identify all Heritage Trees 36 inches in diameter and greater, and any individual oak trees 6 inches in diameter and greater located outside of the woodland area designated for removal.

The proposed project site contains a total of eight trees including four blue oak and four valley oak. In addition, there is one Blue Oak on the adjacent property to the west extending into the project site. The oaks on the site are considered to be a remnant oak woodland with no individual trees. There are a total of two trees 24 inches in diameter and greater on the project site, one tree 24 inches or greater in diameter on the adjacent property to the west, and no heritage trees 36 inches in diameter or greater on or adjacent to the proposed project site. Oak woodland was determined to comprise 0.512 acres in the Study Area and implementation of the proposed project would impact 0.468 acres of the oak woodland.

The Project is already required to comply with the County's ORMP and will be conditioned as such. The requirements apply to both ministerial and discretionary development resulting in impacts to Oak Resources as defined in Chapter 130.39 of the El Dorado County Zoning Ordinance. Chapter 130.39 applies to all privately-owned lands within the unincorporated area of the County at or below the elevation of 4,000 feet above sea level where Oak Resources are present.

If Individual Native Oak Trees, including Heritage Trees, regardless of location within or outside of an oak woodland, will be impacted as part of the permit, the applicant shall mitigate for loss of individual tree(s) by one or more of the following options as specified in the ORMP:

- a. In-lieu Fee payment for individual oak tree removal to be either used by the County to plant oak trees or to be given by the County to a land conservation organization to plant oak trees as shown in Table 6 (Individual Oak Tree In-Lieu Fee) in the ORMP;
- b. Replacement planting on-site consistent with Section 2.4 (Replacement Planting Guidelines) of the ORMP within an area subject to a Deed Restriction or Conservation Easement and utilizing the replacement tree sizes and quantities shown in Table 4 (Oak Tree Replacement Quantities) in the ORMP. On-site replacement planting shall be consistent with Section 2.4 (Replacement Planting Guidelines) of the ORMP;
- c. Replacement planting off-site within an area subject to a Conservation Easement or acquisition in fee title by a land conservation organization utilizing the replanting sizes and quantities specified in Table 4

(Oak Tree Replacement Quantities) in the ORMP. Off-site replacement planting shall be consistent with Section 2.4 (Replacement Planting Guidelines) of the ORMP; or

d. A combination of options a through c above.

While the project site contains and would result in removal of oak woodland, due to existing local policies and ordinances protecting biological resources, conflict with any local policies or ordinances protecting biological resources, such as a tree preservation policy or ordinance, is considered **less than significant**.

f. **Adopted Plans:** There are no Habitat Conservation Plans or Natural Community Conservation Plans that cover the project site and the proposed project will have **no impact** on any such plans.

Finding: With the incorporation of mitigation measures and as conditioned, impacts to Biological Resources would be **less than significant**.

Resources:

County of El Dorado. 2019. Adopted General Plan. Available at:

https://www.edcgov.us/Government/planning/pages/adopted_general_plan.aspx (Accessed October 25, 2022).

County of El Dorado. 2018 Adopted Zoning Ordinance (Amended 2023). Available at:

https://www.edcgov.us/Government/planning/Documents/TITLE%20130%20Master%20Complete%20Adopted%2008-14-18%20AMD%2012-2-20%20AMD%209-10-21%20AMD%2011-16-21_clean_Ord%205163.pdf
(Accessed June 2, 2023).

5. CULTURAL RESOURCES				
Would the project:	Potentially Significant Impact	Less Than Significant with Mitigation	Less Than Significant Impact	No Impact
a) Cause a substantial adverse change in the significance of a historical resource pursuant to in §15064.5?	<input type="checkbox"/>	<input type="checkbox"/>	<input checked="" type="checkbox"/>	<input type="checkbox"/>
b) Cause a substantial adverse change in the significance of an archaeological resource pursuant to §15064.5?	<input type="checkbox"/>	<input type="checkbox"/>	<input checked="" type="checkbox"/>	<input type="checkbox"/>
c) Disturb any human remains, including those interred outside of dedicated cemeteries?	<input type="checkbox"/>	<input type="checkbox"/>	<input checked="" type="checkbox"/>	<input type="checkbox"/>

ENVIRONMENTAL SETTING (BASELINE):

This section provides an assessment of potential impacts to cultural resources associated with the project. The project area, archaeologists locate prehistoric-period habitation sites "along streams or on ridges or knolls, especially those with southern exposure." The region surrounding the Project site is known as the ethnographic-period territory of the Nisenan, also called the Southern Maidu. The Nisenan maintained permanent settlements along major rivers in the Sacramento Valley and foothills; they also periodically traveled to higher elevations (Attachment 4).

REGULATORY SETTING:

Federal Laws, Regulations, and Policies

The National Register of Historic Places

The National Register of Historic Places (NRHP) is the nation’s master inventory of known historic resources. The NRHP is administered by the National Park Service and includes listings of buildings, structures, sites, objects, and districts that possess historic, architectural, engineering, archaeological, or cultural significance at the national, state, or local level. The criteria for listing in the NRHP include resources that:

- A. Are associated with events that have made a significant contribution to the broad patterns of history (events);
- B. Are associated with the lives of persons significant in our past (persons);
- C. Embody the distinctive characteristics of a type, period, or method of construction, or that represent the work of a master, or that possess high artistic values, or that represent a significant and distinguishable entity whose components may lack individual distinction (architecture); or
- D. Have yielded or may likely yield information important in prehistory or history (information potential).

State Laws, Regulations, and Policies

California Register of Historical Resources

Public Resources Code Section 5024.1 establishes the California Register of Historical Resources (CRHR). The register lists all California properties considered to be significant historical resources. The CRHR also includes all properties listed as or determined to be eligible for listing in the NRHP along with properties evaluated under Section 106 of the National Historic Preservation Act. The register also establishes regulations for the criteria for eligibility as well as guidelines for assessing historical integrity and resources that may have special considerations. The criteria for listing in the CRHR include resources that:

- A. Are associated with the events that have made a significant contribution to the broad patterns of California's history and cultural heritage;
- B. Are associated with the lives of persons important in our past;
- C. Embody the distinctive characteristics of a type, period, region, or method of construction, or represent the work of an important creative individual, or possess high artistic values; or
- D. Have yielded, or may be likely to yield, information important in prehistory or history.

The California Register of Historic Places

The California Register of Historic Places (CRHP) program encourages public recognition and protection of resources of architectural, historical, archeological and cultural significance; identifies historical resources for state and local planning purposes; determines eligibility for state historic preservation grant funding; and provides certain protections under the CEQA. The criteria for listing in the CRHP include resources that:

- A. Are associated with events that have made a significant contribution to the broad patterns of local or regional history or the cultural heritage of California or the United States.
- B. Are associated with the lives of persons important to local, California or national history.
- C. Embody the distinctive characteristics of a type, period, region or method of construction or represents the work of a master or possesses high artistic values.
- D. Have yielded, or have the potential to yield, information important to the prehistory or history of the local area, California or the nation.

The State Office of Historic Preservation sponsors the California Historical Resources Information System (CHRIS), a statewide system for managing information on the full range of historical resources identified in California. CHRIS provides an integrated database of site-specific archaeological and historical resources information. The State Office of Historic Preservation also maintains the CRHR, which identifies the State's architectural, historical, archeological and cultural resources. The CRHR includes properties listed in or formally determined eligible for the National Register and lists selected California Registered Historical Landmarks.

Public Resources Code (Section 5024.1[B]) states that any agency proposing a project that could potentially impact a resource listed on the CRHR must first notify the State Historic Preservation Officer and must work with the officer to ensure that the project incorporates "prudent and feasible measures that will eliminate or mitigate the adverse effects."

California Health and Safety Code Section 7050.5 requires that, in the event of discovery or recognition of any human remains in any location other than a dedicated cemetery, there shall be no further excavation or disturbance of the site or any nearby area reasonably suspected to overlie adjacent remains until the coroner of the county in which the human remains are discovered has determined that the remains are not subject to the provisions of Section 27491 of the Government Code or any other related provisions of law concerning investigation of the circumstances, manner and cause of any death. If the coroner determines that the remains are not subject to his or her authority and if the coroner recognizes the human remains to be those of a Native American, or has reason to believe that they are those of a Native American, he or she shall contact, by telephone within 24 hours, the Native American Heritage Commission.

Section 5097.98 of the California Public Resources Code stipulates that whenever the commission receives notification of a discovery of Native American human remains from a county coroner pursuant to subdivision (c) of Section 7050.5 of the Health and Safety Code, it shall immediately notify those persons it believes to be most likely descended from the deceased Native American. The decedents may, with the permission of the owner of the land, or his or her authorized representative, inspect the site of the discovery of the Native American remains and may recommend to the owner or the person responsible for the excavation work means for treating or disposing, with appropriate dignity, the human remains and any associated grave goods. The descendants shall complete their inspection and make their recommendation within 24 hours of their notification by the Native American Heritage Commission. The recommendation may include the scientific removal and nondestructive analysis of human remains and items associated with Native American burials.

CEQA and CEQA Guidelines

Section 21083.2 of CEQA requires that the lead agency determine whether a project may have a significant effect on unique archaeological resources. A unique archaeological resource is defined in CEQA as an archaeological artifact, object, or site about which it can be clearly demonstrated that there is a high probability that it:

- Contains information needed to answer important scientific research questions, and there is demonstrable public interest in that information;
- Has a special or particular quality, such as being the oldest of its type or the best available example of its type; or
- Is directly associated with a scientifically recognized important prehistoric or historic event or person.

Although not specifically inclusive of paleontological resources, these criteria may also help to define “a unique paleontological resource or site.” Measures to avoid, conserve, preserve, or mitigate significant effects on these resources are also provided under CEQA Section 21083.2.

Section 15064.5 of the CEQA Guidelines notes that “a project with an effect that may cause a substantial adverse change in the significance of an historical resource is a project that may have a significant effect on the environment.” Substantial adverse changes include physical changes to the historic resource or to its immediate surroundings, such that the significance of the historic resource would be materially impaired. Lead agencies are expected to identify potentially feasible measures to mitigate significant adverse changes in the significance of a historic resource before they approve such projects. Historic resources are those that are:

- listed in, or determined to be eligible for listing in, the California Register of Historical Resources (CRHR) (Public Resources Code Section 5024.1[k]);
- included in a local register of historic resources (Public Resources Code Section 5020.1) or identified as significant in an historic resource survey meeting the requirements of Public Resources Code Section 5024.1(g); or
- determined by a lead agency to be historically significant.

CEQA Guidelines Section 15064.5 also prescribes the processes and procedures found under Health and Safety Code Section 7050.5 and Public Resources Code Section 5097.95 for addressing the existence of, or probable likelihood of, Native American human remains, as well as the unexpected discovery of any human remains within a project site. This includes consultation with the appropriate Native American tribes. CEQA Guidelines Section 15126.4 provides further guidance about minimizing effects to historical resources through the application of mitigation measures. Mitigation measures must be legally binding and fully enforceable.

The lead agency having jurisdiction over a project is also responsible to ensure that paleontological resources are protected in compliance with CEQA and other applicable statutes. Paleontological and historical resource management is also addressed in Public Resources Code Section 5097.5, “Archaeological, Paleontological, and Historical Sites.” This statute defines as a misdemeanor any unauthorized disturbance or removal of a fossil site or remains on public land and specifies that state agencies may undertake surveys, excavations, or other operations as necessary on state lands to preserve or record paleontological resources. This statute would apply to any construction or other related project impacts that would occur on state-owned or state-managed lands. The County General Plan contains policies describing specific, enforceable measures to protect cultural resources and the treatment of resources if and when found.

APPLICABLE THRESHOLDS OF SIGNIFICANCE:

The effects to cultural resources that may be considered significant contained in Appendix G of the CEQA Guidelines (Environmental Checklist) was used to establish a threshold of significance. In general, significant impacts are considered those activities that diminish the integrity, research potential, or other characteristics that make a historical or cultural resource significant or important. A substantial adverse effect on Cultural Resources would occur if the implementation of the proposed project would:

- Disrupt, alter, or adversely affect a prehistoric or historic archaeological site or property that is historically or culturally significant to a community or ethnic or social group; or a paleontological site except as a part of a scientific study;
- Affect a landmark of cultural/historical importance;
- Conflict with established recreational, educational, religious or scientific uses of the area; or
- Conflict with adopted environmental plans and goals of the community where it is located.

ENVIRONMENTAL STUDIES PERFORMED AND METHODOLOGY:

A complete records search was conducted by searching the California Historic Resources Information System (CHRIS) maps for cultural resource site records and survey reports in El Dorado County within a ¼-mile radius of the Project site (Attachment 4). The project search area is situated in the Sierra Nevada foothills. Within the search area, the records show no evidence of nineteenth-century or twentieth-century historical activity. The records search determined that given the extent of known cultural resources, patterns of local history, and the environmental setting, there is low potential for locating prehistoric-period or historic-period cultural resources in the immediate vicinity of the project site.

IMPACT ANALYSES AND CONCLUSIONS:

- a.-d. **Historic, Archeological Resources, Human Remains.** According to the complete records search conducted by searching CHRIS maps for cultural resource site records and survey reports in El Dorado County within a ¼-mile radius of the Project site, the Project area is not considered sensitive. The search stated that no significant prehistoric archaeological sites, features, or artifacts were found, nor any significant historical buildings, structures or objects, and no further analysis was recommended. While further archival and/or field study by a cultural resource professional was not recommended, to ensure potential impacts to an undiscovered cultural resource remains at a level of less than significant, the following standard condition of approval is applied to all development projects:

If any suspected cultural resources are discovered during ground disturbing construction activities, all work shall cease within 100 feet of the find, or an agreed upon distance based on the project area and nature of the find. Preservation in place is the preferred alternative under CEQA, and every effort must be made to preserve the cultural resource in place, including through project redesign. Culturally appropriate treatment may be, but is not limited to, processing materials for reburial, minimizing handling of cultural objects, leaving objects in place within the landscape, returning objects to a location within the project area where they will not be subject to future impacts.

The contractor shall implement any measures deemed by CEQA lead agency to be necessary and feasible to preserve in place, avoid, or minimize impacts to the resource, including, but not limited to, facilitating the appropriate treatment of the find, as necessary. Treatment that preserves or restores the cultural character and integrity of a cultural resource may include culturally appropriate recovery of cultural objects, and reburial of cultural objects or cultural soil.

Work at the discovery location cannot resume until all necessary investigation and evaluation of the discovery under the requirements of CEQA have been satisfied.

FINDING: With the standard condition of approval to be included with this Project, potential impacts to cultural resources with implementation of the Project would remain at a **less-than-significant** level.

6. ENERGY				
Would the project:	Potentially Significant Impact	Less Than Significant with Mitigation	Less Than Significant Impact	No Impact
a) Result in potentially significant environmental impact due to wasteful, inefficient, or unnecessary consumption of energy resources, during project construction or operation?	<input type="checkbox"/>	<input type="checkbox"/>	<input checked="" type="checkbox"/>	<input type="checkbox"/>
b) Conflict with or obstruct a state or local plan for renewable energy or energy efficiency?	<input type="checkbox"/>	<input type="checkbox"/>	<input checked="" type="checkbox"/>	<input type="checkbox"/>

ENVIRONMENTAL SETTING (BASELINE):

This section provides an evaluation of existing energy production and consumption conditions, as well as potential energy use and related impacts from the proposed project. Electrical power and natural gas are provided to the proposed project site by Pacific Gas & Electric Company (PG&E). PG&E obtains its electricity supplies from power plants and natural gas fields in northern California and from energy purchased outside its service area and delivered through high voltage transmission lines. PG&E also obtains its natural gas supplies from natural gas fields in northern California and from sources outside of California.

California Energy Overview:

Electricity

California’s electricity needs are satisfied by a variety of entities, including investor-owned utilities, publicly owned utilities, electric service providers and community choice aggregators. In 2021, the California power mix totaled 277,764 gigawatt hours (GWh) with in-state generation accounting for 194,1127 GWh, or 70 percent, of the State’s power mix and the remaining electricity came from out-of-state imports (CEC 2022a). Table 6-1 below provides a summary of California’s electricity sources as of 2021.

**Table 6-1
California Electricity Sources 2021**

Fuel Type	Percent of California Power (%)
Coal	3.0
Natural Gas	37.9
Oil	0.0
Other (petroleum coke, waste heat)	0.2
Nuclear	9.3
Large Hydro	9.2
Unspecified	6.8
Renewables	33.6

Source: CEC 2022a

Natural Gas

Natural gas provides the largest portion of the total in-state capacity and electricity generation in California, with nearly 45 percent of the natural gas burned in California used for electricity generation in 2020. Much of the remainder was consumed in the residential (21 percent), industrial (25 percent), and commercial (9 percent) sectors. California continues to depend upon out-of-state imports for nearly 90 percent of its natural gas supply (CEC 2022b).

Transportation Fuels

Transportation accounts for a major portion of California's energy budget. Automobiles and trucks consume gasoline and diesel fuel, which are nonrenewable energy products derived from crude oil. Gasoline is the most used transportation fuel in California, with 97 percent of all gasoline being consumed by light-duty cars, pickup trucks, and sport utility vehicles (SUVs) (CEC 2022c). In 2021, 13.8 billion gallons of gasoline were sold in California (CEC 2022c). Diesel fuel is the second most consumed fuel in California, used by heavy-duty trucks, delivery vehicles, buses, trains, ships, boats, and farm and construction equipment. In 2021, 1.6 billion gallons of diesel were sold in California (CEC 2022d).

REGULATORY SETTING:

Federal Laws, Regulations, and Policies

Energy Independence and Security act of 2007

House of Representatives Bill 6 (HR 6), the federal Energy Independence and Security Act of 2007, established new standards for a few equipment types not already subjected to a standard and updated some existing standards. Arguably the most substantial new standard that HR 6 established is for general service lighting that is being deployed in two phases. First, phased in between 2012 through 2014, common light bulbs were required to use about 20 to 30 percent less energy than previous incandescent bulbs. Second, by 2020, light bulbs must consume 60 percent less energy than today's bulbs; this requirement would effectively phase out the incandescent light bulb.

Energy Improvement and Extension Act of 2007

The formerly entitled "Renewable Energy and Job Creation Act of 2008," or Division B of HR 1424, was signed into law by President Bush in October 2008. The signed bill contains \$18 billion in incentives for clean and renewable energy technologies, as well as for energy efficiency improvements.

State Laws, Regulations, and Policies

California Integrated Energy Policy

Senate Bill 1389, passed in 2002, requires the California Energy Commission (CEC) to prepare an Integrated Energy Policy Report for the governor and legislature every 2 years, and to provide an update in the year between reports. The report analyzes data and provides policy recommendations on trends and issues concerning electricity and natural gas, transportation, energy efficiency, renewable energy, and public interest energy research. The 2019 Integrated Energy Policy Report covers a broad range of topics, including decarbonizing buildings, integrating renewables, energy efficiency, energy equity, integrating renewable energy, updates on Southern California electricity reliability, climate adaptation activities for the energy sector, natural gas assessment, transportation energy demand forecast, and the California Energy Demand Forecast.

California Building Standards Code (California Code of Regulations, Title 24)

The 2019 Building Energy Efficiency Standards is mandatory statewide and comprises of Title 24, Parts 1 and 6, of the California Code of Regulations. Local government agencies may adopt and enforce energy efficiency standards for newly constructed buildings, additions, alterations, and repairs provided the California Energy Commission finds that the standards will require buildings to consume no more energy than permitted by Title 24, Part 6. Such local standards may include adopting the requirements of Title 24, Part 6 before their effective date, requiring additional energy conservation measures, or setting stricter energy budgets. Title 24, Part 11 contains additional energy measures that are applicable to the project under the California Green Building Standards Code (CALGreen).

Local Laws, Regulations, and Policies

El Dorado County General Plan

The El Dorado County General Plan Public Services and Utilities Element encourages energy efficiency development within the County by imposing two policies:

- *Policy 5.6.2.1*- Require energy conserving landscaping plans for all projects requiring design review or other discretionary approval.
- *Policy 5.6.2.2*- All new subdivisions should include design components that take advantage of passive or natural summer cooling and/or winter solar access, or both, when possible.

APPLICABLE THRESHOLDS OF SIGNIFICANCE:

The list of energy resource effects that may be considered significant contained in Appendix G of the CEQA Guidelines (Environmental Checklist) was used to establish a threshold of significance.

ENVIRONMENTAL STUDIES PERFORMED AND METHODOLOGY:

Based on the lack of significant increase in energy demand from the proposed project site, no environmental studies relating to energy resources were prepared for the proposed project.

IMPACT ANALYSES AND CONCLUSIONS:

- a. **Energy Consumption:** To implement the proposed project, it is expected that construction equipment (e.g., tractors, excavators, loaders, generators, trucks, light-duty vehicles) would use petroleum fuels (diesel and gasoline products) and would not use on-site electricity or natural gas sources. Construction of the proposed residential would occur over a short duration and are temporary; therefore, the wasteful, inefficient, or unnecessary use of petroleum fuels would not occur.

Implementation of the proposed project would result in development of new buildings that would increase the long-term demand for energy resources. The proposed residential development would be subject to meeting statewide mandatory energy requirements as outlined in Title 24, Part 6, of the California Code of Regulations. Title 24, Part 11, which contains additional energy measures that are applicable to the project under CALGreen. Prior to project approval, the project applicant would be required to ensure that the project would meet Title 24 requirements applicable at that time, as required by State regulations through their plan review process. Therefore, with the inherent increase in efficiency of building code regulations, the project would not result in a wasteful use of energy. Impacts related to energy use would be **less than significant**.

- b. **Energy Plans and Efficiency Standards:** Part 6 of Title 24 of the California Code of Regulations was established in 1978 and serves to enhance and regulate California's building standards. Specifically, Part 6 establishes energy efficiency standards for residential and non-residential buildings constructed in California to reduce energy demand and consumption. Part 6 is updated periodically to incorporate and consider new energy efficiency technologies and methodologies. Title 24 also includes Part 11, CALGreen, which institutes mandatory minimum environmental performance standards for all ground-up, new construction of commercial, low-rise residential, and State-owned buildings, as well as schools and hospitals. The proposed project would meet Title 24 and CALGreen standards to reduce energy demand and increase energy efficiency. Overall, the proposed project would not conflict with existing energy standards and regulations; therefore, impacts during construction and operation of the project would be **less than significant**.

FINDING: With conformance with statewide mandatory energy requirements as outlined in Title 24, Parts 6 and 11, of the California Code of Regulations, the proposed project would have a **less than significant** impact on energy resources.

References Used:

- California Energy Commission. 2022a. 2021 Total System Electric Generation. Available at:
<https://www.energy.ca.gov/data-reports/energy-almanac/california-electricity-data/2021-total-system-electric-generation> (Accessed October 19, 2022).
- California Energy Commission. 2022b. Supply and Demand of Natural Gas in California. Available at:
<https://www.energy.ca.gov/data-reports/energy-almanac/californias-natural-gas-market/supply-and-demand-natural-gas-california> (Accessed October 19, 2022).
- California Energy Commission. 2022c. California Gasoline Data, Facts, and Statistics. Available at:
<https://www.energy.ca.gov/data-reports/energy-almanac/transportation-energy/california-gasoline-data-facts-and-statistics> (Accessed October 19, 2022).
- California Energy Commission. 2022d. California Retail Fuel Outlet Annual Reporting (CEC-A15) Results. Available at: <https://www.energy.ca.gov/data-reports/energy-almanac/transportation-energy/california-retail-fuel-outlet-annual-reporting> (Accessed October 19, 2022).

7. GEOLOGY AND SOILS				
Would the project:	Potentially Significant Impact	Less Than Significant with Mitigation	Less Than Significant Impact	No Impact
a) Directly or indirectly cause potential substantial adverse effects, including the risk of loss, injury, or death involving:	<input type="checkbox"/>	<input type="checkbox"/>	<input checked="" type="checkbox"/>	<input type="checkbox"/>
i) Rupture of a known earthquake fault, as delineated on the most recent Alquist-Priolo Earthquake Fault Zoning Map issued by the State Geologist for the area or based on other substantial evidence of a known fault? Refer to Division of Mines and Geology Special Publication 42.	<input type="checkbox"/>	<input type="checkbox"/>	<input checked="" type="checkbox"/>	<input type="checkbox"/>
ii) Strong seismic ground shaking?	<input type="checkbox"/>	<input type="checkbox"/>	<input checked="" type="checkbox"/>	<input type="checkbox"/>
iii) Seismic-related ground failure, including liquefaction?	<input type="checkbox"/>	<input type="checkbox"/>	<input checked="" type="checkbox"/>	<input type="checkbox"/>
iv) Landslides?	<input type="checkbox"/>	<input type="checkbox"/>	<input checked="" type="checkbox"/>	<input type="checkbox"/>
b) Result in substantial soil erosion or the loss of topsoil?	<input type="checkbox"/>	<input type="checkbox"/>	<input checked="" type="checkbox"/>	<input type="checkbox"/>
c) Be located on a geologic unit or soil that is unstable, or that would become unstable as a result of the project, and potentially result in on- or off-site landslide, lateral spreading, subsidence, liquefaction or collapse?	<input type="checkbox"/>	<input type="checkbox"/>	<input checked="" type="checkbox"/>	<input type="checkbox"/>
d) Be located on expansive soil, as defined in Table 18-1-B of the Uniform Building Code (1994), creating substantial direct or indirect risks to life or property?	<input type="checkbox"/>	<input type="checkbox"/>	<input checked="" type="checkbox"/>	<input type="checkbox"/>
e) Have soils incapable of adequately supporting the use of septic tanks or alternative waste water disposal systems where sewers are not available for the disposal of waste water?	<input type="checkbox"/>	<input type="checkbox"/>	<input checked="" type="checkbox"/>	<input type="checkbox"/>
f) Directly or indirectly destroy a unique paleontological resource or site or unique geologic feature?	<input type="checkbox"/>	<input type="checkbox"/>	<input checked="" type="checkbox"/>	<input type="checkbox"/>

ENVIRONMENTAL SETTING (BASELINE):

The project site is located within the Sierra Nevada geomorphic province in the western foothills of the Sierra Nevada. The site elevation is approximately 1,150 feet above mean sea level (amsl). The site is mapped as being underlain by Auburn silt loam and Sobrante silt loam. Auburn silt loam is the primary soil type on the site and encompasses the majority of the site, with Sobrante silt loam occurring in a small strip along the southeast corner of the site.

Auburn silt loam occurs on hills between 120 to 3,000 feet amsl and consists of residuum weathered from basic igneous rock and/or basic residuum weathered from metamorphic rock. A typical profile is silt loam from 0 to 14 inches and unweathered bedrock from 14 to 18 inches. Lithic bedrock occurs at a depth of 14 to 18 inches. This soil

series is well drained with a frequency of flooding of “none” and ponding of “none” and a depth to water table of more than 80 inches (Attachment 3).

Sobranite silt loam occurs on hillslopes between 120 and 3,500 feet amsl and consists of residuum weathered from metamorphic rock. A typical profile is silt loam from 0 to 11 inches, clay loam from 11 to 24 inches, weathered bedrock from 24 to 30 inches, and unweathered bedrock from 30 to 34 inches. This soil series is well drained with a frequency of flooding of “none” and ponding of “none” and a depth to water table of more than 80 inches, with paralithic bedrock located at a depth of 24 to 30 inches and lithic bedrock at a depth of 30 to 34 inches (Attachment 3).

Historical seismic activity and fault and seismic hazards mapping in the project vicinity indicate that the area has relatively low potential for seismic activity (El Dorado County Sheriff 2018). The site is not located within a current Alquist-Priolo Earthquake Fault Zone, and no active faults appear to be trending towards the site (California Department of Conservation 2022).

REGULATORY SETTING:

Federal Laws, Regulations, and Policies

National Earthquake Hazards Reduction Act

The National Earthquake Hazards Reduction Act of 1977 (Public Law 95-124) and creation of the National Earthquake Hazards Reduction Program (NEHRP) established a long-term earthquake risk-reduction program to better understand, predict, and mitigate risks associated with seismic events. The following four federal agencies are responsible for coordinating activities under NEHRP: USGS, National Science Foundation (NSF), Federal Emergency Management Agency (FEMA), and National Institute of Standards and Technology (NIST). Since its inception, NEHRP has shifted its focus from earthquake prediction to hazard reduction. The program objectives are to:

1. Educate the public, including State and local officials, about earthquake phenomena;
2. Develop technologically and economically feasible design and construction methods and procedures to make new and existing structures, in areas of seismic risk, earthquake resistant;
3. Implement, to the greatest extent practicable, in all areas of high or moderate seismic risk, a system (including personnel, technology, and procedures) for predicting damaging earthquakes and for identifying, evaluating, and accurately characterizing seismic hazards;
4. Develop, publicize, and promote, in conjunction with State and local officials and professional organizations, model building codes and other means to encourage consideration of information about seismic risk in making decisions about land-use policy and construction activity;
5. Develop, in areas of seismic risk, improved understanding of, and capability with respect to, earthquake-related issues;
6. Develop ways to increase the use of existing scientific and engineering knowledge to mitigate earthquake hazards; and
7. Develop ways to assure the availability of affordable earthquake insurance (NEHRP 2022).

Implementation of NEHRP objectives is accomplished primarily through original research, publications, and recommendations and guidelines for state, regional, and local agencies in the development of plans and policies to promote safety and emergency planning.

State Laws, Regulations, and Policies

Alquist–Priolo Earthquake Fault Zoning Act

The Alquist–Priolo Earthquake Fault Zoning Act (Public Resources Code Section 2621 *et seq.*) was passed to reduce the risk to life and property from surface faulting in California. The Alquist–Priolo Act prohibits construction of most types of structures intended for human occupancy on the surface traces of active faults and strictly regulates construction in the corridors along active faults (earthquake fault zones). It also defines criteria for identifying active faults, giving legal weight to terms such as “active,” and establishes a process for reviewing building proposals in and adjacent to earthquake fault zones. Under the Alquist–Priolo Act, faults are zoned and construction along or across them is strictly regulated if they are “sufficiently active” and “well defined.” Before a project can be permitted, cities and counties are required to have a geologic investigation conducted to demonstrate that the proposed buildings would not be constructed across active faults.

Seismic Hazards Mapping Act

The Seismic Hazards Mapping Act of 1990 (Public Resources Code Sections 2690–2699.6) establishes statewide minimum public safety standards for mitigation of earthquake hazards. While the Alquist–Priolo Act addresses surface fault rupture, the Seismic Hazards Mapping Act addresses other earthquake-related hazards, including strong ground shaking, liquefaction, and seismically induced landslides. Its provisions are similar in concept to those of the Alquist–Priolo Act. The state is charged with identifying and mapping areas at risk of strong ground shaking, liquefaction, landslides, and other seismic hazards, and cities and counties are required to regulate development within mapped seismic hazard zones. In addition, the act addresses not only seismically induced hazards but also expansive soils, settlement, and slope stability.

Mapping and other information generated pursuant to the SHMA is to be made available to local governments for planning and development purposes. The State requires: (1) local governments to incorporate site-specific geotechnical hazard investigations and associated hazard mitigation, as part of the local construction permit approval process; and (2) the agent for a property seller or the seller if acting without an agent, must disclose to any prospective buyer if the property is located within a Seismic Hazard Zone. Under the Seismic Hazards Mapping Act, cities and counties may withhold the development permits for a site within seismic hazard zones until appropriate site-specific geologic and/or geotechnical investigations have been carried out and measures to reduce potential damage have been incorporated into the development plans.

California Building Standards Code

Title 24 CCR, also known as the California Building Standards Code (CBC), specifies standards for geologic and seismic hazards other than surface faulting. These codes are administered and updated by the California Building Standards Commission. CBC specifies criteria for open excavation, seismic design, and load-bearing capacity directly related to construction in California.

Paleontological Resources

The CEQA lead agency having jurisdiction over a project is also responsible to ensure that paleontological resources are protected in compliance with CEQA and other applicable statutes. Paleontological resource management is also addressed in Public Resources Code Section 5097.5, “Archaeological, Paleontological, and Historical Sites.” This statute defines as a misdemeanor any unauthorized disturbance or removal of a fossil site or remains on public land and specifies that state agencies may undertake surveys, excavations, or other operations as necessary on state lands to preserve or record paleontological resources. This statute would apply to any construction or other related project impacts that would occur on state-owned or state-managed lands.

APPLICABLE THRESHOLDS OF SIGNIFICANCE:

The list of geology and soils effects that may be considered significant contained in Appendix G of the CEQA Guidelines (Environmental Checklist) was used to establish a threshold of significance.

ENVIRONMENTAL STUDIES PERFORMED AND METHODOLOGY:

A site-specific, geotechnical exploration and soils report was prepared in 2022 which discusses conditions found at the project site (Attachment 5).

IMPACT ANALYSES AND CONCLUSIONS:

a. Seismic Hazards:

- i) **Rupture of Fault:** Seismically induced ground rupture is defined as the physical displacement of surface deposits in response to an earthquake's seismic waves. The magnitude and nature of fault rupture can vary for different faults or even along different strands of the same fault. Surface rupture can damage or collapse buildings, cause severe damage to roads and pavement structures, and cause failure of overhead as well as underground utilities.

According to the California Department of Conservation Division of Mines and Geology, there are no Alquist-Priolo fault zones within the west slope of El Dorado County. However, a fault zone has been located in the Tahoe Basin and Echo Lakes area. The West Tahoe Fault runs along the base of the range front at the west side of the Tahoe Basin. The West Tahoe Fault has a mapped length of 28 miles. South of Emerald Bay the West Tahoe Fault extends onshore as two parallel strands. In the lake, the fault has clearly defined scarps that offset submarine fans, lake-bottom sediments, and the McKinney Bay slide deposits (DOC 2022). There is clear evidence that the discussed onshore portion of the West Tahoe Fault is active with multiple events in the Holocene and poses a surface rupture hazard.

There are no earthquake faults delineated on Alquist-Priolo Fault Zone maps in the project site (DOC 2022). Since the project property is not traversed by a known active fault and is not within 200 feet of an active fault trace, surface fault rupture is not considered to be a significant hazard for the project site. The project would not expose people or structures to substantial adverse effects from a fault rupture because of the distance between the project site and the closest fault. Any potential impacts from implementation of the proposed project would be **less than significant**.

- ii) **Ground Shaking:** Faults in the project vicinity are related to the Foothills Fault System that includes branches of the Melones and Bear Mountains Fault Zones. The Foothills Fault System trends north to northwest with most faults having a steep easterly dip. The eastern branch of the Bear Mountains Fault zone and the Melones Fault zone are mapped approximately 2.5 miles and 10 miles to the east of the project site, respectively. The western branch of the Bear Mountains Fault zone is mapped approximately 5 miles to the west of the project site. A discontinuous strand of the Melones Fault zone, which is truncated by a granitic intrusion near the town of El Dorado, is indicated approximately 5 miles east of the project site.

The site vicinity is located in an area generally characterized as having low seismicity. The Foothills Fault System is well-defined but has not been classified as active or potentially active. The nearest known active faults to the site are the North Tahoe Fault, located approximately 67 miles to the northeast, the Genoa Fault located approximately 61 miles to the east, the Green Valley Fault located approximately 70 miles to the southwest, and the Dunnigan Hills Fault located approximately 49 miles to the northwest of the site (Foothill Geotechnical 2019). In addition, the potential for seismic ground shaking in the project area would be considered remote for the reason stated in Section i) above. Any potential impacts due to seismic impacts would be addressed through compliance with the Uniform Building Code (UBC). All structures would be built to meet the construction standards of the UBC for the appropriate seismic zone. The impact would be **less than significant**.

- iii) **Ground Failure:** Seismic liquefaction occurs when excess pore pressures are generated in loose, saturated, generally cohesionless soil during earthquake shaking, causing the soil to experience a partial to complete loss of shear strength. Such a loss of shear strength can result in settlement and/or horizontal movement (lateral spreading) of the soil mass. Based on the absence of permanently elevated groundwater table, the

relatively low seismicity of the project area, and the relatively shallow depth to rock, the potential for seismically induced damage due to liquefaction, surface ruptures, and settlement is considered low (Attachment 5). All structures would be built to meet the construction standards of the UBC for the appropriate seismic zone. The impact would be **less than significant**.

- iv) **Landslide:** The property is situated within a relatively flat area with gradual, natural slopes. In addition, all grading activities onsite would be required to comply with the El Dorado County Grading, Erosion Control and Sediment Ordinance. The impact would be **less than significant**.

- b. **Soil Erosion:** A site-specific geotechnical engineering study identified the project would incorporate cuts and fill with a maximum slope orientation of 2H:1V (horizontal:vertical). A cut slope orientation of 2H:1V is generally considered stable with the material types identified at the project site. In addition, a fill slope constructed at the same orientation would be considered stable if compacted to the engineered fill recommendations of the geotechnical engineering study (Attachment 5). All grading activities onsite would comply with the El Dorado County Grading, Erosion and Sediment Control Ordinance including the implementation of pre- and post-construction BMPs. Implemented BMPs are required to be consistent with the County's California Stormwater Pollution Prevention Plan (SWPPP) issued by the State Water Resources Control Board to eliminate run-off and erosion and sediment controls. Any grading activities exceeding 250 cubic yards of graded material or grading completed for the purpose of supporting a structure must meet the provisions contained in the County of El Dorado Grading, Erosion, and Sediment Control Ordinance. Any future construction would require similar review for compliance with the County SWPPP. The proposed project's compliance with County Ordinance requirements and implementation of recommended improvements in the site-specific geotechnical exploration and soils report would keep potential impacts to soil erosion at a **less-than-significant** level.

- c. **Geologic Hazards:** Based on the Seismic Hazards Mapping Program administered by the California Geological Survey, no portion of El Dorado County is located in a Seismic Hazard Zone or those areas prone to liquefaction and earthquake-induced landslides (DOC 2022). Therefore, El Dorado County is not considered to be at risk from liquefaction hazards. Lateral spreading is typically associated with areas experiencing liquefaction. Because liquefaction hazards are not present in El Dorado County, the county is not at risk for lateral spreading. All grading activities would comply with the El Dorado County Grading, Erosion Control and Sediment Ordinance. With compliance with County Ordinance requirements, proposed project impacts would be **less than significant**.

- d. **Expansive Soils:** Expansive soils are those that greatly increase in volume when they absorb water and shrink when they dry out. When buildings are placed on expansive soils, foundations may rise each wet season and fall each dry season. This movement may result in cracking foundations, distortion of structures, and warping of doors and windows. Occasional pockets of plastic materials (clay soils) are encountered at the project site. However, the majority of soils at the project are of non-plastic material (e.g., rock, sand, non-plastic silt) and are generally considered to be non-expansive. Due to the limited presence of plastic material at the project site, special design considerations for expansive soils are not anticipated for the design or construction of proposed site improvements (e.g., duplexes, utilities) (Attachment 5). Development of the site would also be required to comply with the El Dorado County Grading, Erosion and Sediment Control Ordinance and the development plans for any structures would be required to implement the Seismic construction standards. With compliance with County Ordinance requirements, proposed project impacts would be **less than significant**.

- e. **Septic Capability:** No septic is proposed as part of the proposed project. The project site would be served by public sewer. A Facilities Improvement Letter (FIL) from the El Dorado Irrigation District (EID) was obtained and identifies there is existing sewer line at the project site has adequate capacity. There would be **no impact**.

FINDING: A review of the soils and geologic conditions on the project site determined that the proposed project would not result in a substantial adverse effect. All grading activities would be required to comply with the El Dorado County Grading, Erosion Control and Sediment Ordinance which would address potential impacts related to soil

erosion, landslides and other geologic impacts. Future development would be required to comply with the UBC which would address potential seismic related impacts. With compliance with County Ordinance requirements, impacts would be **less than significant**.

References Used:

Department of Conservation (DOC), 2022. Available at: <https://maps.conservation.ca.gov/cgs/fam/> (Accessed February 15, 2022).

El Dorado County Sheriff, Office of Emergency Services, 2018. *El Dorado County Local Hazard Mitigation Plan* (Figure 3-14, Maximum Expectable Earthquake Intensity). Available at: https://www.edcgov.us/Government/sheriff/Documents/ElDoradoCounty_LHMP.pdf (Accessed December 24, 2022).

California Department of Conservation, 2022. *EQ Zapp: California Earthquake Hazards Zone Application*. Available at: <https://www.conservation.ca.gov/cgs/geohazards/eq-zapp> (Accessed December 24, 2022).

National Earthquake Hazards Reduction Program (NEHRP), 2022. *National Earthquake Hazards Reduction Program, About Us*. Available at: <https://www.nehrp.gov/about/PL108-360.htm> (Accessed December 24, 2022).

8. GREENHOUSE GAS EMISSIONS				
Would the project:	Potentially Significant Impact	Less Than Significant with Mitigation	Less Than Significant Impact	No Impact
a) Generate greenhouse gas emissions, either directly or indirectly, that may have a significant impact on the environment?	<input type="checkbox"/>	<input type="checkbox"/>	<input checked="" type="checkbox"/>	<input type="checkbox"/>
b) Conflict with an applicable plan, policy or regulation adopted for the purpose of reducing the emissions of greenhouse gases?	<input type="checkbox"/>	<input type="checkbox"/>	<input checked="" type="checkbox"/>	<input type="checkbox"/>

ENVIRONMENTAL SETTING (BASELINE):

Cumulative greenhouse gas (GHG) emissions are believed to contribute to an increased greenhouse effect and global climate change, which may result in sea level rise, changes in precipitation, habitat, temperature, wildfires, air pollution levels, and changes in the frequency and intensity of weather-related events. While criteria pollutants and toxic air contaminants are pollutants of regional and local concern (see Section III. Air Quality above); GHGs are global pollutants. The primary land-use related GHGs are carbon dioxide (CO₂), methane (CH₄), and nitrous oxides (N₂O). The individual pollutant’s ability to retain infrared radiation represents its “global warming potential” and is expressed in terms of CO₂ equivalents; therefore, CO₂ is the benchmark having a global warming potential of 1. Methane has a global warming potential of 21 and thus has a 21 times greater global warming effect per metric ton of CH₄ than CO₂. Nitrous Oxide has a global warming potential of 310. Emissions are expressed in annual metric tons of CO₂ equivalent units of measure (i.e., MTCO₂e/yr). The three other main GHGs include hydrofluorocarbons, perfluorocarbons, and sulfur hexafluoride. While these compounds have significantly higher global warming potentials (ranging in the thousands), all three typically are not a concern in land-use development projects and are usually only used in specific industrial processes.

The primary man-made source of CO₂ is the burning of fossil fuels; the two largest sources being coal burning to produce electricity and petroleum burning in combustion engines. The primary sources of man-made CH₄ are natural gas systems losses (production, processing, storage, transmission, and distribution of gas), enteric fermentation (digestion from livestock), and landfill off-gassing. The primary source of man-made N₂O comes from agricultural soil management (e.g., fertilizers) along with fossil fuel combustion at a very distant second. In El Dorado County, the primary source of GHGs is fossil fuel combustion mainly in the transportation sector (estimated at 70% of countywide GHG emissions). A distant second are residential sources (approximately 20%), and commercial/industrial sources are third (approximately 7%). The remaining sources of GHGs include waste/landfill (approximately 3%) and agricultural (<1%) operations.

REGULATORY SETTING:

Federal Laws, Regulations, and Policies

At the federal level, USEPA has developed regulations to reduce GHG emissions from motor vehicles and has developed permitting requirements for large stationary emitters of GHGs. On April 1, 2010, USEPA and the National Highway Traffic Safety Administration (NHTSA) established a program to reduce GHG emissions and improve fuel economy standards for new model year 2012-2016 cars and light trucks. On August 9, 2011, USEPA and the NHTSA announced standards to reduce GHG emissions and improve fuel efficiency for heavy-duty trucks and buses.

State Laws, Regulations, and Policies

In September 2006, Governor Arnold Schwarzenegger signed Assembly Bill (AB) 32, the *California Climate Solutions Act of 2006* (Stats. 2006, ch. 488) (Health & Safety Code, Section 38500 et seq.). AB 32 requires a statewide GHG emissions reduction to 1990 levels by the year 2020. AB 32 requires the California Air Resources Board (CARB) to implement and enforce the statewide cap. When AB 32 was signed, California's annual GHG emissions were estimated at 600 million metric tons of CO₂ equivalent (MMTCO₂e) while 1990 levels were estimated at 427 MMTCO₂e. Setting 427 MMTCO₂e as the emissions target for 2020, current (2006) GHG emissions levels must be reduced by 29%. CARB adopted the AB 32 Scoping Plan in December 2008 establishing various actions the state would implement to achieve this reduction (CARB 2008). The Scoping Plan recommends a community-wide GHG reduction goal for local governments of 15%.

In December 2018, OPR issued a Technical Advisory providing interim guidance regarding a proposed project's GHG emissions and contribution to global climate change. In the absence of adopted local or statewide thresholds, OPR recommends the following approach for analyzing GHG emissions: Identify and quantify the project's GHG emissions, assess the significance of the impact on climate change; and if the impact is found to be significant, identify alternatives and/or Mitigation Measures that would reduce the impact to less than significant levels (OPR 2018).

APPLICABLE THRESHOLDS OF SIGNIFICANCE:

The list of greenhouse gas emission effects that may be considered significant contained in Appendix G of the CEQA Guidelines (Environmental Checklist) was used to establish a threshold of significance.

ENVIRONMENTAL STUDIES PERFORMED AND METHODOLOGY:

Based on review of the project by the El Dorado County AQMD, the project was determined to not cause a significant air quality impact. Therefore, no environmental studies relating specifically to GHG emissions were prepared for the project.

IMPACT ANALYSES AND CONCLUSIONS:

CEQA does not provide clear direction on addressing climate change. It requires lead agencies identify project GHG emissions impacts and their "significance," but is not clear what constitutes a "significant" impact. As stated above, GHG impacts are inherently cumulative, and since no single project could cause global climate change, the CEQA test is if impacts are "cumulatively considerable." Not all projects emitting GHG contribute significantly to climate change. CEQA authorizes reliance on previously approved plans (e.g., a Climate Action Plan (CAP)) and mitigation programs for adequately analyzing and mitigating GHG emissions to a less than significant level. "Tiering" from such a programmatic-level document is the preferred method to address GHG emissions. El Dorado County does not have an adopted CAP or similar program-level document; therefore, the project's GHG emissions must be addressed at the project-level.

Unlike thresholds of significance established for criteria air pollutants in El Dorado County AQMD's *Guide to Air Quality Assessment* (February 2002) ("CEQA Guide"), the District has not adopted GHG emissions thresholds for land use development projects. In the absence of County adopted thresholds, AQMD recommends using the adopted thresholds of other lead agencies which are based on consistency with the goals of AB 32. Since climate change is a global problem and the location of the individual source of GHG emissions is somewhat irrelevant, it's appropriate to use thresholds established by other jurisdictions as a basis for impact significance determinations. Projects exceeding these thresholds would have a potentially significant impact and be required to mitigate those impacts to a less than significant level. Until the County adopts a CAP consistent with CEQA Guidelines Section 15183.5, and/or establishes GHG thresholds, the County will follow an interim approach to evaluating GHG emissions utilizing significance criteria adopted by the Sacramento Metropolitan Air Quality Management District (SMAQMD) to determine the significance of GHG emissions. The SMAQMD Air Quality Significance Thresholds identify a construction-related and an operation-related maximum annual threshold of significance for land development and construction projects of 1,100 metric tons of CO₂e per year (SMAQMD 2020). The SMAQMD has developed a screening table using

CalEEMod which allows quick assessment of projects to screen out those below the thresholds as their impacts would be less than significant. For projects below the threshold, no further GHG analysis is required.

- a. **Greenhouse Gas Emissions:** Emissions of GHGs contributing to global climate change are attributable in large part to human activities associated with the industrial/manufacturing, utility, transportation, residential, and agricultural sectors. Therefore, the cumulative global emissions of GHGs contributing to global climate change can be attributed to every nation, region, and city, and virtually every individual on Earth. An individual project's GHG emissions are at a micro-scale level relative to global emissions and effects to global climate change; however, an individual project could result in a cumulatively considerable incremental contribution to a significant cumulative macro-scale impact. As such, impacts related to emissions of GHG are inherently considered cumulative impacts.

Implementation of the proposed project is not expected to cumulatively contribute to increases of GHG emissions. Estimated GHG emissions attributable to future development would be primarily associated with increases of carbon dioxide (CO₂) and, to a lesser extent, other GHG pollutants such as methane (CH₄) and nitrous oxide (N₂O) associated with area sources, mobile sources or vehicles, utilities (e.g., electricity, natural gas), water usage, wastewater generation, and the generation of solid waste. The primary source of GHG emissions for the proposed project would be mobile source emissions. The common unit of measurement for GHG is expressed in terms of annual metric tons of CO₂ equivalents (MTCO₂e/yr).

The El Dorado County AQMD has not formally adopted thresholds for evaluating GHG emissions but has recommended the use of thresholds adopted by the SMAQMD. The thresholds of significance established by SMAQMD, and used by El Dorado County AQMD, were developed to identify emissions levels for which a project would not be expected to substantially conflict with existing California legislation adopted to reduce statewide GHG emissions needed to move towards climate stabilization. As identified in the SMAQMD Thresholds of Significance Table, updated April 2020, if a proposed project results in emissions less than 1,100 MTCO₂e/yr during either construction or operation, the proposed project would be anticipated to result in a less-than-significant impact related to GHG emissions.

GHG emissions are quantified with CalEEMod using the same assumptions as presented in the Air Quality section above and compared to the thresholds of significance noted above. The proposed project's required compliance with the 2019 California Building Energy Efficiency Standards Code would also ensure the project meets current applicable requirements.

Construction Emissions: Construction-related GHG emissions are a one-time release and are, therefore, not typically expected to generate a significant contribution to global climate change because global climate change is inherently a cumulative effect that occurs over a long period of time and is quantified on a yearly basis. However, the proposed project's construction GHG emissions (53 MTCO₂e/yr) would not exceed the SMAQMD significance threshold and are not expected to be a cumulatively considerable contribution to global climate change.

Operational GHG Emissions: The proposed project operational GHG emissions at full buildout (206 MTCO₂e/yr) would not exceed the SMAQMD significance threshold. Therefore, the proposed project would not result in a cumulatively considerable contribution to global climate change.

FINDING: The project would not generate GHG emissions that would have a significant impact on the environment, or conflict with any applicable plan, policy, or regulation adopted for the purpose of reducing the emissions of GHGs. Therefore, the project would not result in a cumulatively considerable incremental contribution to impacts related to GHG emissions or climate change. Impacts would be **less than significant**.

References Used:

California Air Resources Board (CARB), 2008. *Climate Change Scoping Plan*. Available at: ww2.arb.ca.gov/sites/default/files/classic/cc/scopingplan/document/adopted_scoping_plan.pdf (Accessed December 24, 2022).

California Governor's Office of Planning and Research (OPR), 2018. *Discussion Draft CEQA and Climate Change Advisory*. Available at: https://opr.ca.gov/docs/20181228-Discussion_Draft_Climate_Change_Adivsory.pdf (Accessed December 24, 2022).

Sacramento Metropolitan Air Quality Management District (SMAQMD), 2020. *Thresholds of Significance Table*. Available at: <https://www.airquality.org/LandUseTransportation/Documents/CH2ThresholdsTable4-2020.pdf> (Accessed December 24, 2022).

9. HAZARDS AND HAZARDOUS MATERIALS				
Would the project:	Potentially Significant Impact	Less Than Significant with Mitigation	Less Than Significant Impact	No Impact
a) Create a significant hazard to the public or the environment through the routine transport, use, or disposal of hazardous materials?	<input type="checkbox"/>	<input type="checkbox"/>	<input checked="" type="checkbox"/>	<input type="checkbox"/>
b) Create a significant hazard to the public or the environment through reasonably foreseeable upset and accident conditions involving the release of hazardous materials into the environment?	<input type="checkbox"/>	<input type="checkbox"/>	<input checked="" type="checkbox"/>	<input type="checkbox"/>
c) Emit hazardous emissions or handle hazardous or acutely hazardous materials, substances, or waste within one-quarter mile of an existing or proposed school?	<input type="checkbox"/>	<input type="checkbox"/>	<input checked="" type="checkbox"/>	<input type="checkbox"/>
d) Be located on a site which is included on a list of hazardous materials sites compiled pursuant to Government Code Section 65962.5 and, as a result, would it create a significant hazard to the public or the environment?	<input type="checkbox"/>	<input type="checkbox"/>	<input type="checkbox"/>	<input checked="" type="checkbox"/>
e) For a project located within an airport land use plan or, where such a plan has not been adopted, within two miles of a public airport or public use airport, would the project result in a safety hazard or excessive noise for people residing or working in the project area?	<input type="checkbox"/>	<input type="checkbox"/>	<input checked="" type="checkbox"/>	<input type="checkbox"/>
f) Impair implementation of or physically interfere with an adopted emergency response plan or emergency evacuation plan?	<input type="checkbox"/>	<input type="checkbox"/>	<input checked="" type="checkbox"/>	<input type="checkbox"/>
g) Expose people or structures, either directly or indirectly, to a significant risk of loss, injury or death involving wildland fires?	<input type="checkbox"/>	<input type="checkbox"/>	<input checked="" type="checkbox"/>	<input type="checkbox"/>

ENVIRONMENTAL SETTING (BASELINE):

The project site is vacant and has no history of any previous activities that could have handled hazardous materials. In addition, the area surrounding the Project site does not include any land uses that handle substantial amounts hazardous materials.

REGULATORY SETTING:

Hazardous materials and hazardous wastes are subject to extensive federal, state, and local regulations to protect public health and the environment. These regulations provide definitions of hazardous materials; establish reporting requirements; set guidelines for handling, storage, transport, and disposal of hazardous wastes; and require health and safety provisions for workers and the public. The major federal, state, and regional agencies enforcing these

regulations are USEPA and the Occupational Safety and Health Administration (OSHA); California Department of Toxic Substances Control (DTSC); California Department of Industrial Relations, Division of Occupational Safety and Health (Cal/OSHA); California Governor's Office of Emergency Services (Cal OES); and El Dorado County Environmental Management Department, Hazardous Materials.

Federal Laws, Regulations, and Policies

Comprehensive Environmental Response, Compensation, and Liability Act

The Comprehensive Environmental Response, Compensation, and Liability Act (CERCLA, also called the Superfund Act; 42 USC Section 9601 *et seq.*) is intended to protect the public and the environment from the effects of past hazardous waste disposal activities and new hazardous material spills. Under CERCLA, USEPA has the authority to seek the parties responsible for hazardous materials releases and to ensure their cooperation in site remediation. CERCLA also provides federal funding (through the "Superfund") for the remediation of hazardous materials contamination. The Superfund Amendments and Reauthorization Act of 1986 (Public Law 99-499) amends some provisions of CERCLA and provides for a Community Right-to-Know program.

Resource Conservation and Recovery Act

The Resource Conservation and Recovery Act of 1976 (RCRA; 42 USC Section 6901 *et seq.*), as amended by the Hazardous and Solid Waste Amendments of 1984, is the primary federal law for the regulation of solid waste and hazardous waste in the United States. These laws provide for the "cradle-to-grave" regulation of hazardous wastes, including generation, transportation, treatment, storage, and disposal. Any business, institution, or other entity that generates hazardous waste is required to identify and track its hazardous waste from the point of generation until it is recycled, reused, or disposed of.

USEPA has primary responsibility for implementing RCRA, but individual states are encouraged to seek authorization to implement some or all RCRA provisions. California received authority to implement the RCRA program in August 1992. DTSC is responsible for implementing the RCRA program in addition to California's own hazardous waste laws, which are collectively known as the Hazardous Waste Control Law.

Energy Policy Act of 2005

Title XV, Subtitle B of the Energy Policy Act of 2005 (the Underground Storage Tank Compliance Act of 2005) contains amendments to Subtitle I of the Solid Waste Disposal Act, the original legislation that created the Underground Storage Tank (UST) Program. As defined by law, a UST is "any one or combination of tanks, including pipes connected thereto, that is used for the storage of hazardous substances and that is substantially or totally beneath the surface of the ground." In cooperation with USEPA, SWRCB oversees the UST Program. The intent is to protect public health and safety and the environment from releases of petroleum and other hazardous substances from tanks. The four primary program elements include leak prevention (implemented by Certified Unified Program Agencies [CUPAs], described in more detail below), cleanup of leaking tanks, enforcement of UST requirements, and tank integrity testing.

Spill Prevention, Control, and Countermeasure Rule

USEPA's Spill Prevention, Control, and Countermeasure (SPCC) Rule (40 CFR, Part 112) apply to facilities with a single above-ground storage tank (AST) with a storage capacity greater than 660 gallons, or multiple tanks with a combined capacity greater than 1,320 gallons. The rule includes requirements for oil spill prevention, preparedness, and response to prevent oil discharges to navigable waters and adjoining shorelines. The rule requires specific facilities to prepare, amend, and implement SPCC Plans.

Occupational Safety and Health Administration

OSHA is responsible at the federal level for ensuring worker safety. OSHA sets federal standards for implementation of workplace training, exposure limits, and safety procedures for the handling of hazardous substances (as well as other hazards). OSHA also establishes criteria by which each state can implement its own health and safety program.

Code of Federal Regulations (14 CFR) Part 77

14 CFR Part 77.9 is designed to promote air safety and the efficient use of navigable airspace. Implementation of the code is administered by the Federal Aviation Administration (FAA). If an organization plans to sponsor any construction or alterations that might affect navigable airspace, a Notice of Proposed Construction or Alteration (FAA Form 7460-1) must be filed. The code provides specific guidance regarding FAA notification requirements.

State Laws, Regulations, and Policies

Safe Drinking Water and Toxic Enforcement Act of 1986 – Proposition 65

The Safe Drinking Water and Toxic Enforcement Act of 1986, more commonly known as Proposition 65, protects the state's drinking water sources from contamination with chemicals known to cause cancer, birth defects, or other reproductive harm. Proposition 65 also requires businesses to inform the public of exposure to such chemicals in the products they purchase, in their homes or workplaces, or that are released into the environment. In accordance with Proposition 65, the California Governor's Office publishes, at least annually, a list of such chemicals. OEHHA, an agency under the California Environmental Protection Agency (CalEPA), is the lead agency for implementation of the Proposition 65 program. Proposition 65 is enforced through the California Attorney General's Office; however, district and city attorneys and any individual acting in the public interest may also file a lawsuit against a business alleged to be in violation of Proposition 65 regulations.

The Unified Program

The Unified Program consolidates, coordinates, and makes consistent the administrative requirements, permits, inspections, and enforcement activities of six environmental and emergency response programs. CalEPA and other state agencies set the standards for their programs, while local governments (CUPAs) implement the standards. For each county, the CUPA regulates/oversees the following:

- Hazardous materials business plans;
- California accidental release prevention plans or federal risk management plans;
- The operation of USTs and ASTs;
- Universal waste and hazardous waste generators and handlers;
- On-site hazardous waste treatment;
- Inspections, permitting, and enforcement;
- Proposition 65 reporting; and
- Emergency response.

Hazardous Materials Business Plans

Hazardous materials business plans are required for businesses that handle hazardous materials in quantities greater than or equal to 55 gallons of a liquid, 500 pounds of a solid, or 200 cubic feet (cf) of compressed gas, or extremely hazardous substances above the threshold planning quantity (40 CFR, Part 355, Appendix A) (CalEPA 2022). Business plans are required to include an inventory of the hazardous materials used/stored by the business, a site map, an emergency plan, and a training program for employees (Cal OES 2015). In addition, business plan information is provided electronically to a statewide information management system, verified by the applicable CUPA, and transmitted to agencies responsible for the protection of public health and safety (i.e., local fire department, hazardous material response team, and local environmental regulatory groups) (Cal OES 2015).

California Occupational Safety and Health Administration

Cal/OSHA assumes primary responsibility for developing and enforcing workplace safety regulations in California. Cal/OSHA regulations pertaining to the use of hazardous materials in the workplace (CCR Title 8) include requirements for safety training, availability of safety equipment, accident and illness prevention programs, warnings about exposure to hazardous substances, and preparation of emergency action and fire prevention plans.

Hazard communication program regulations that are enforced by Cal/OSHA require workplaces to maintain procedures for identifying and labeling hazardous substances, inform workers about the hazards associated with hazardous substances and their handling, and prepare health and safety plans to protect workers at hazardous waste sites. Employers must also make material safety data sheets available to employees and document employee information and training programs. In addition, Cal/OSHA has established maximum permissible RF radiation exposure limits for workers (Title 8 CCR Section 5085[b]), and requires warning signs where RF radiation might exceed the specified limits (Title 8 CCR Section 5085 [c]).

California Accidental Release Prevention

The purpose of the California Accidental Release Prevention (CalARP) program is to prevent accidental releases of substances that can cause serious harm to the public and the environment, to minimize the damage if releases do occur, and to satisfy community right-to-know laws. In accordance with this program, businesses that handle more than a threshold quantity of regulated substance are required to develop a risk management plan (RMP). This RMP must provide a detailed analysis of potential risk factors and associated mitigation measures that can be implemented to reduce accident potential. CUPAs implement the CalARP program through review of RMPs, facility inspections, and public access to information that is not confidential or a trade secret.

California Department of Forestry and Fire Protection Wildland Fire Management

The Office of the State Fire Marshal and the CAL FIRE administer state policies regarding wildland fire safety. Construction contractors must comply with the following requirements in the Public Resources Code during construction activities at any sites with forest-, brush-, or grass-covered land:

- Earthmoving and portable equipment with internal combustion engines must be equipped with a spark arrestor to reduce the potential for igniting a wildland fire (Public Resources Code Section 4442).
- Appropriate fire-suppression equipment must be maintained from April 1 to December 1, the highest-danger period for fires (Public Resources Code Section 4428).
- On days when a burning permit is required, flammable materials must be removed to a distance of 10 feet from any equipment that could produce a spark, fire, or flame, and the construction contractor must maintain the appropriate fire suppression equipment (Public Resources Code Section 4427).
- On days when a burning permit is required, portable tools powered by gasoline fueled internal combustion engines must not be used within 25 feet of any flammable materials (Public Resources Code Section 4431).

California Highway Patrol

CHP, along with Caltrans, enforce and monitor hazardous materials and waste transportation laws and regulations in California. These agencies determine container types used and license hazardous waste haulers for hazardous waste transportation on public roads. All motor carriers and drivers involved in transportation of hazardous materials must apply for and obtain a hazardous materials transportation license from CHP.

Local Laws, Regulations, and Policies

A map of the fuel loading in the County (General Plan Figure HS-1) shows the fire hazard severity classifications of the SRAs in El Dorado County, as established by CDF. The classification system provides three classes of fire hazards: Moderate, High, and Very High. Fire Hazard Ordinance (Chapter 8.08) requires defensible space as described by the State Public Resources Code, including the incorporation and maintenance of a 30-foot fire break or vegetation fuel clearance around structures in fire hazard zones. The County's requirements on emergency access, signing and

numbering, and emergency water are more stringent than those required by state law. The Fire Hazard Ordinance also establishes limits on campfires, fireworks, smoking, and incinerators for all discretionary and ministerial developments.

APPLICABLE THRESHOLDS OF SIGNIFICANCE:

The list of hazards and hazardous material effects that may be considered significant contained in Appendix G of the CEQA Guidelines (Environmental Checklist) was used to establish a threshold of significance.

ENVIRONMENTAL STUDIES PERFORMED AND METHODOLOGY:

Based on the lack of known historical or current hazardous material use on or near the proposed project site, no environmental studies relating to hazards and hazardous materials were prepared for the proposed project.

IMPACT ANALYSES AND CONCLUSIONS:

A substantial adverse effect due to Hazards or Hazardous Materials would occur if implementation of the project would:

- Expose people and property to hazards associated with the use, storage, transport, and disposal of hazardous materials where the risk of such exposure could not be reduced through implementation of Federal, State, and local laws and regulations;
 - Expose people and property to risks associated with wildland fires where such risks could not be reduced through implementation of proper fuel management techniques, buffers and landscape setbacks, structural design features, and emergency access; or
 - Expose people to safety hazards as a result of former on-site mining operations.
- a.-c. **Hazardous Materials:** The project would not involve the routine transportation, use, or disposal of hazardous materials such as construction materials, paints, fuels, landscaping materials, and household cleaning supplies. Project construction may involve some hazardous materials temporarily but any storage would occur on a small scale and, therefore, impacts would be **less than significant**.
- d. **Hazardous Sites:** The project site is not included on a list of or near any hazardous materials sites pursuant to Government Code section 65962.5. There would be **no impact**.
- e.-f. **Aircraft Hazards, Private Airstrips:** The closest airport to the proposed project site is the Cameron Airpark located approximately 2 miles to the northeast. As shown on the El Dorado County Airport Safety Zones, the Project site is not located within an Airport Safety Zone (EDC 2012). Impacts would be **less than significant**.
- g. **Emergency Plan:** The project was distributed to local law enforcement El Dorado County Sheriff's Office, for review. The project would not impair implementation of any emergency response plan or emergency evacuation plan. Impacts would be **less than significant**.
- h. **Wildfire Hazards:** The project site is in the high fire hazard area for wildland fire pursuant to Figure HS-1 of the Fire Hazard Rating in El Dorado County of the General Plan (2019). The Cameron Park Fire Department in cooperation with CAL FIRE would review and comment on the project improvement plans at time of building permit review. Refer to Section 20 for additional discussion regarding wildfire. Impacts would be **less than significant**.

FINDING: The project would not expose the area to hazards relating to the use, storage, transport, or disposal of hazardous materials. The proposed project would not be located in an Airport Safety Zone and would not impair implementation of any emergency response plan or emergency evacuation plan. Lastly, the proposed project would

be reviewed by CAL FIRE to ensure any site-specific wildfire risks are reduced by required implementation of project improvements. For this Hazards and Hazardous Materials category, impacts would be **less than significant**.

Resources used:

El Dorado County (EDC), 2012. *Draft Zoning Ordinance Map, dated September 20, 2012*. Available at:
https://www.edcgov.us/government/longrangeplanning/landuse/supportingdocuments/planningdocuments/documents/PRD2_detail_1.pdf (Accessed February 15, 2022).

California Environmental Protection Agency (CalEPA), 2022. *Hazardous Materials Business Plan Program*.
Available at: <https://calepa.ca.gov/hazardous-materials-business-plan-program/> (Accessed December 24, 2022).

El Dorado County, 2019. *El Dorado County General Plan (amended 2019)*. Available at:
https://www.edcgov.us/Government/planning/pages/adopted_general_plan.aspx (Accessed December 24, 2022).

10. HYDROLOGY AND WATER QUALITY				
Would the project:	Potentially Significant Impact	Less Than Significant with Mitigation	Less Than Significant Impact	No Impact
a) Violate any water quality standards or waste discharge requirements or otherwise substantially degrade surface or ground water quality?	<input type="checkbox"/>	<input type="checkbox"/>	<input checked="" type="checkbox"/>	<input type="checkbox"/>
b) Substantially decrease groundwater supplies or interfere substantially with groundwater recharge such the project may impede sustainable groundwater management of the basin?	<input type="checkbox"/>	<input type="checkbox"/>	<input checked="" type="checkbox"/>	<input type="checkbox"/>
c) Substantially alter the existing drainage pattern of the site or area, including through the alteration of the course of a stream or river or through the addition of impervious surfaces, in a manner which would:	<input type="checkbox"/>	<input type="checkbox"/>	<input checked="" type="checkbox"/>	<input type="checkbox"/>
(i) result in substantial erosion or siltation on- or off-site;	<input type="checkbox"/>	<input type="checkbox"/>	<input checked="" type="checkbox"/>	<input type="checkbox"/>
(ii) substantially increase the rate or amount of surface runoff in a manner which would result in flooding on- or offsite;	<input type="checkbox"/>	<input type="checkbox"/>	<input checked="" type="checkbox"/>	<input type="checkbox"/>
(iii) create or contribute runoff water which would exceed the capacity of existing or planned stormwater drainage systems or provide substantial additional sources of polluted runoff; or	<input type="checkbox"/>	<input type="checkbox"/>	<input checked="" type="checkbox"/>	<input type="checkbox"/>
(iv) impede or redirect flood flows?	<input type="checkbox"/>	<input type="checkbox"/>	<input checked="" type="checkbox"/>	<input type="checkbox"/>
d) In flood hazard, tsunami, or seiche zones, risk release of pollutants due to project inundation?	<input type="checkbox"/>	<input type="checkbox"/>	<input checked="" type="checkbox"/>	<input type="checkbox"/>
e) Conflict with or obstruct implementation of a water quality control plan or sustainable groundwater management plan?	<input type="checkbox"/>	<input type="checkbox"/>	<input checked="" type="checkbox"/>	<input type="checkbox"/>

ENVIRONMENTAL SETTING (BASELINE):

The site is covered with grasses and has a gentle, up-slope from east to west. The site and the surrounding areas are covered with grasses, some oaks, and developed properties. The drainage in the area flows from Bass Lake Road to the southeast. The upstream drainage swale flows into a combined watershed that results in an intermittent stream that flows south where it crosses Highway 50 and then drains into Deer Creek. The predevelopment 100-year, 24-hour discharge from the overall 114-acre watershed through the site measured at the point of interest is estimated to be 104 cubic feet per second (cfs) (Attachment 6).

REGULATORY SETTING:

Federal Laws, Regulations, and Policies

Clean Water Act

The Clean Water Act (CWA) is the primary federal law that protects the quality of the nation's surface waters, including lakes, rivers, and coastal wetlands. The key sections pertaining to water quality regulation for the Proposed Project are CWA Section 303 and Section 402.

Section 303(d) — Listing of Impaired Water Bodies

Under CWA Section 303(d), states are required to identify "impaired water bodies" (those not meeting established water quality standards), identify the pollutants causing the impairment, establish priority rankings for waters on the list, and develop a schedule for the development of control plans to improve water quality. USEPA then approves the State's recommended list of impaired waters or adds and/or removes waterbodies.

Section 402—NPDES Permits for Stormwater Discharge

CWA Section 402 regulates construction-related stormwater discharges to surface waters through the NPDES, which is officially administered by USEPA. In California, USEPA has delegated its authority to the State Water Resources Control Board (SWRCB), which, in turn, delegates implementation responsibility to the nine RWQCBs, as discussed below in reference to the Porter-Cologne Water Quality Control Act.

The NPDES program provides for both general (those that cover a number of similar or related activities) and individual (activity- or project-specific) permits. General Permit for Construction Activities: Most construction projects that disturb 1.0 or more acre of land are required to obtain coverage under SWRCB's General Permit for Storm Water Discharges Associated with Construction and Land Disturbance Activities (Order 2009-0009-DWQ as amended by 2010-0014-DWQ and 2012-0006-DWQ). The general permit requires that the applicant file a public notice of intent to discharge stormwater and prepare and implement a Stormwater Pollution Prevention Plan (SWPPP). The SWPPP must include a site map and a description of the proposed construction activities, demonstrate compliance with relevant local ordinances and regulations, and present a list of BMPs that will be implemented to prevent soil erosion and protect against discharge of sediment and other construction-related pollutants to surface waters. Permittees are further required to monitor construction activities and report compliance to ensure that BMPs are correctly implemented and are effective in controlling the discharge of construction-related pollutants.

Municipal Stormwater Permitting Program

SWRCB regulates stormwater discharges from municipal separate storm sewer systems (MS4s) through its Municipal Storm Water Permitting Program (SWRCB 2022). Permits are issued under two phases depending on the size of the urbanized area/municipality. Phase I MS4 permits are issued for medium (population between 100,000 and 250,000 people) and large (population of 250,000 or more people) municipalities, and are often issued to a group of co-permittees within a metropolitan area. Phase I permits have been issued since 1990. Beginning in 2003, SWRCB began issuing Phase II MS4 permits for smaller municipalities (population less than 100,000).

El Dorado County is covered under two SWRCB Regional Boards. The West Slope Phase II Municipal Separate Storm Sewer Systems (MS4) NPDES Permit is administered by the Central Valley Regional Water Quality Control Board (RWQCB) (Region Five). The Lake Tahoe Phase I MS4 NPDES Permit is administered by the Lahontan RWQCB (Region Six). The current West Slope MS4 NPDES Permit was adopted by the SWRCB on February 5, 2013. The Permit became effective on July 1, 2013 for a term of five years and focuses on the enhancement of surface water quality within high priority urbanized areas. The current Lake Tahoe MS4 NPDES Permit was adopted and took effect on December 6, 2011 for a term of five years. The Permit incorporated the Lake Tahoe Total Maximum Daily Load (TMDL) and the Lake Clarity Crediting Program (LCCP) to account for the reduction of fine sediment particles and nutrients discharged to Lake Tahoe.

On May 19, 2015, the El Dorado County Board of Supervisors formally adopted revisions to the Storm Water Quality Ordinance (Ordinance 4992). Previously applicable only to the Lake Tahoe Basin, the ordinance establishes legal authority for the entire unincorporated portion of the County. The purpose of the ordinance is to 1) protect health, safety, and general welfare, 2) enhance and protect the quality of Waters of the State by reducing pollutants in storm water discharges to the maximum extent practicable and controlling non-storm water discharges to the storm drain system, and 3) cause the use of Best Management Practices to reduce the adverse effects of polluted runoff discharges on Waters of the State.

National Flood Insurance Program

The Federal Emergency Management Agency (FEMA) administers the National Flood Insurance Program (NFIP) to provide subsidized flood insurance to communities complying with FEMA regulations that limit development in floodplains. The NFIP regulations permit development within special flood hazard zones provided that residential structures are raised above the base flood elevation of a 100-year flood event. Non-residential structures are required either to provide flood proofing construction techniques for that portion of structures below the 100-year flood elevation or to elevate above the 100-year flood elevation. The regulations also apply to substantial improvements of existing structures.

State Laws, Regulations, and Policies

Porter–Cologne Water Quality Control Act

The Porter–Cologne Water Quality Control Act (known as the Porter–Cologne Act), passed in 1969, dovetails with the CWA (see discussion of the CWA above). It established the SWRCB and divided the state into nine regions, each overseen by an RWQCB. SWRCB is the primary State agency responsible for protecting the quality of the state’s surface water and groundwater supplies; however, much of the SWRCB’s daily implementation authority is delegated to the nine RWQCBs, which are responsible for implementing CWA Sections 401, 402, and 303[d]. In general, SWRCB manages water rights and regulates statewide water quality, whereas RWQCBs focus on water quality within their respective regions.

The Porter–Cologne Act requires RWQCBs to develop water quality control plans (also known as basin plans) that designate beneficial uses of California’s major surface-water bodies and groundwater basins and establish specific narrative and numerical water quality objectives for those waters. Beneficial uses represent the services and qualities of a waterbody (i.e., the reasons that the waterbody is considered valuable). Water quality objectives reflect the standards necessary to protect and support those beneficial uses. Basin plan standards are primarily implemented by regulating waste discharges so that water quality objectives are met. Under the Porter–Cologne Act, basin plans must be updated every 3 years.

APPLICABLE THRESHOLDS OF SIGNIFICANCE:

The list of hydrology and water quality effects that may be considered significant contained in Appendix G of the CEQA Guidelines (Environmental Checklist) was used to establish a threshold of significance.

ENVIRONMENTAL STUDIES PERFORMED AND METHODOLOGY:

A site-specific drainage study report was prepared in 2021 which discusses water drainage conditions found at the project site (Attachment 6).

IMPACT ANALYSES AND CONCLUSIONS:

A substantial adverse effect on Hydrology and Water Quality would occur if the implementation of the project would:

- Expose residents to flood hazards by being located within the 100-year floodplain as defined by the Federal Emergency Management Agency;

- Cause substantial change in the rate and amount of surface runoff leaving the project site ultimately causing a substantial change in the amount of water in a stream, river or other waterway;
 - Substantially interfere with groundwater recharge;
 - Cause degradation of water quality (temperature, dissolved oxygen, turbidity and/or other typical stormwater pollutants) in the project area; or
 - Cause degradation of groundwater quality in the vicinity of the project site.
- a, e. **Water Quality Standards:** Some waste discharge may occur as part of the project. Erosion control would be required as part of any future building or grading permit. Stormwater runoff from potential development would contain water quality protection features in accordance with a potential NPDES stormwater permit, as deemed applicable. The project would comply with County Ordinances and standards regarding waste discharge and, therefore, the project would not be expected to violate water quality standards and would not conflict with or obstruct implementation of a water quality control plan. Impacts related to water quality would be **less than significant**.
- b. **Groundwater Supplies:** The geology of the Western Slope portion of El Dorado County is principally hard, crystalline, igneous, or metamorphic rock overlain with a thin mantle of sediment or soil. Groundwater in this region is found in fractures, joints, cracks, and fault zones within the bedrock mass. These discrete fracture areas are typically vertical in orientation rather than horizontal as in sedimentary or alluvial aquifers. Recharge is predominantly through rainfall infiltrating into the fractures. Movement of this groundwater is very limited due to the lack of porosity in the bedrock. Wells are typically drilled to depths ranging from 80 to 300 feet in depth. There is no evidence that the project will substantially reduce or alter the quantity of groundwater in the vicinity, or materially interfere with groundwater recharge in the area of the proposed project. The project is not anticipated to affect potential groundwater supplies above pre-project levels. Water for the project would be provided by public water connection to the El Dorado Irrigation District (EID). Impacts to groundwater supplies would be **less than significant**.
- c. **Drainage Patterns:** A grading permit would be required to address grading, erosion and sediment control for construction activities associated with implementing the proposed project. Construction activities would be required to adhere to the El Dorado County Grading, Erosion Control and Sediment Ordinance. The County ordinance requires the use of BMPs and implementation of standard requirements to minimize degradation of water quality during construction activities. Preliminary Grading and Drainage Plans for the proposed project have been submitted to the County and show the location of proposed development including the building site, parking, storm drains/drain inlets, and bio-swales (Attachment F). Storm water runoff for Lots 5 and 6 would be directed to an existing 42-inch storm drain located at the northwest corner of the site. Storm water runoff for the remainder of runoff at the site would be directed to water quality vegetative swales constructed adjacent to the Greenwood Lane right-of-way and then subsequently overland to an existing curb and gutter. The proposed bioswales on the project site would provide treatment of stormwater prior to the water leaving the site and would conform with the County's post construction water quality requirements of a Phase II MS4 permit. With implementation of BMPs and standard requirements, along with project design, impacts on drainage patterns would remain **less than significant**.
- d. **Flood-related Hazards:** The project site is not located within any mapped 100-year flood areas and would not result in the construction of any structures that would impede or redirect flood flows (Attachment 6). A project-specific hydrology and hydraulic analysis was conducted for the proposed project site. The analysis concludes that placement of the proposed residential development on the project site within the existing floodplain would not increase the 100-year 24-hour water surface elevations through the project site. Therefore, the project as designed in grading plans would have a negligible impact on the existing 100-year floodplain elevations throughout the project site.

A drainage study was also prepared for the proposed project site and determined the post-developed site would produce no increase in peak runoff compared to the existing pre-developed condition due to increase

in impervious surfaces such as asphalt pavement and building roofs. This is a result of the proposed project being less than 1 acre of the 114-acre watershed area (0.8%) and, thus, the increase in impervious area is small. In addition, the soil type of the project site is already a more impervious type therefore, the increased runoff from the developed site will not as great as it would be if the undeveloped site had a more pervious soil type (Attachment 6).

The risk of exposure to seiche or tsunami would be remote because of the project site is not located near any large water body. In addition, the project site does not contain any steep slopes that could pose a risk to mudflows.

Implementation of the proposed residential development would not result in creating any flood hazards. For the reasons described above, impacts related to flood hazards would be **less than significant**.

FINDING: The proposed project would be required to address any potential erosion and sediment control through project design. No significant hydrological impacts are expected with the development of the proposed project either directly or indirectly. With implementation and compliance with the County Ordinances and standards, impacts would be **less than significant**.

References used:

California State Water Resources Control Board (SWRCB), 2022. *Storm Water Program*. Available at: https://www.waterboards.ca.gov/water_issues/programs/stormwater/ (Accessed December 24, 2022).

11. LAND USE PLANNING				
Would the project:	Potentially Significant Impact	Less Than Significant with Mitigation	Less Than Significant Impact	No Impact
a) Physically divide an established community?	<input type="checkbox"/>	<input type="checkbox"/>	<input checked="" type="checkbox"/>	<input type="checkbox"/>
b) Cause a significant environmental impact due to a conflict with any land use plan, policy, or regulation adopted for the purpose of avoiding or mitigating an environmental effect?	<input type="checkbox"/>	<input type="checkbox"/>	<input checked="" type="checkbox"/>	<input type="checkbox"/>

ENVIRONMENTAL SETTING (BASELINE):

The project site is currently vacant and is designated for residential land uses in the El Dorado County General Plan and Zoning Code. The adjacent-neighboring parcels currently include residential and commercial areas along with the Camerado Springs Middle School to the west.

REGULATORY SETTING:

California State law requires that each City and County adopt a General Plan "for the physical development of the City and any land outside its boundaries which bears relation to its planning." Ideally, a General Plan is designed to address the issues facing the City or County for the next 15-20 years. The General Plan expresses the community's development goals and incorporates public policies relative to the distribution of future public and private land uses. The El Dorado County General Plan was updated in 2015. The 2013-2021 Housing Element was adopted in 2013 and is currently undergoing a comprehensive update.

APPLICABLE THRESHOLDS OF SIGNIFICANCE:

The list of land use and planning resource effects that may be considered significant contained in Appendix G of the CEQA Guidelines (Environmental Checklist) was used to establish a threshold of significance.

ENVIRONMENTAL STUDIES PERFORMED AND METHODOLOGY:

Based on the lack of land use changes in or near the proposed project site, no environmental studies relating to land use and planning were prepared for the proposed project.

IMPACT ANALYSES AND CONCLUSIONS:

- a. **Established Community:** The project is located within the Cameron Park Community Region. Community Regions are defined as those areas which are appropriate for the highest intensity of self-sustaining compact urban-type development or suburban type development within the County based on the municipal spheres of influence, availability of infrastructure, public services, major transportation corridors and travel patterns, the location of major topographic patterns and features, and the ability to provide and maintain appropriate transitions at Community Region boundaries. The project site is adjacent to existing residential to the south and commercial development to the east across Greenwood Lane. The project site is also adjacent to the Camerado Springs Middle School to the west. Based on the project site's location adjacent to existing residential and commercial development along with the proposed land use (residential), implementation of the project would result in an extension of the existing development patterns and, therefore, would not conflict with the existing land use pattern in the area nor physically divide an established community. Impacts would be **less than significant**.

- b. **Land Use Consistency:** The project site has a General Plan land use designation of residential and is zoned for Multi-Unit Residential within a Design Review Combining Zone (RM-DC). The purpose of the Multi-Unit Residential zone is to regulate “lands which are most capable of supporting the highest density of development within the County, based on topography, infrastructure, and circulation availabilities and constraints, as well as proximity to employment centers, public facilities, recreation, and shopping. It is applied to regulate and promote the development of multi-unit dwellings, including apartments, condominiums, and townhouses, while ensuring compatibility with surrounding lower density residential neighborhoods.”

Implementation of the proposed project would change the current Design Review Combining Zone (DC) designation to Planned Development (PD). The purpose of the Planned Development (-PD) Combining Zone is to “implement the General Plan by providing innovative planning and development techniques that allow the use of flexible development standards; provide for a combination of different land uses which are complimentary, but may not in all aspects conform to the existing zoning regulations; allow clustering of intensive land uses to minimize impacts on various natural resources; avoid cultural resources where feasible; promote more efficient utilization of land; reflect the character, identity and scale of local communities; protect suitable land for agricultural uses; and minimize use compatibility issues and environmental impacts.”

The proposed uses for residential are allowed uses within the RM-PD zone, is consistent with the residential General Plan land use designation, and would be compatible with the existing, surrounding development. In addition, the project has been designed in a manner to fit in with the surrounding residential and commercial uses including the use of neutral earth tone colors and installation of landscape. Impacts would be **less than significant**.

FINDING: The proposed use of the site would be consistent with uses allowed in the Cameron Park Community Region, with the General Plan, and Zoning Ordinance. For this Land Use Planning section, impacts would be **less than significant**.

12. MINERAL RESOURCES				
Would the project:	Potentially Significant Impact	Less Than Significant with Mitigation	Less Than Significant Impact	No Impact
a) Result in the loss of availability of a known mineral resource that would be of value to the region and the residents of the state?	<input type="checkbox"/>	<input type="checkbox"/>	<input type="checkbox"/>	<input checked="" type="checkbox"/>
b) Result in the loss of availability of a locally-important mineral resource recovery site delineated on a local general plan, specific plan or other land use plan?	<input type="checkbox"/>	<input type="checkbox"/>	<input type="checkbox"/>	<input checked="" type="checkbox"/>

ENVIRONMENTAL SETTING (BASELINE):

The project site does not contain any known mineral resources of value to the region. In addition, the project site is not identified as containing mineral resources in any El Dorado County plan.

REGULATORY SETTING:

Federal Laws, Regulations, and Policies

No federal laws, regulations, or policies apply to mineral resources and the proposed project.

State Laws, Regulations, and Policies

Surface Mining and Reclamation Act

The Surface Mining and Reclamation Act of 1975 (SMARA) requires that the State Mining and Geology Board identify, map, and classify aggregate resources throughout California that contain regionally significant mineral resources. Designations of land areas are assigned by CDC and California Geological Survey following analysis of geologic reports and maps, field investigations, and using information about the locations of active sand and gravel mining operations. Local jurisdictions are required to enact planning procedures to guide mineral conservation and extraction at particular sites and to incorporate mineral resource management policies into their general plans.

The California Mineral Land Classification System represents the relationship between knowledge of mineral deposits and their economic characteristics (grade and size). The nomenclature used with the California Mineral Land Classification System is important in communicating mineral potential information in activities such as mineral land classification, and usage of these terms are incorporated into the criteria developed for assigning mineral resource zones. Lands classified MRZ-2 are areas that contain identified mineral resources. Areas classified as MRZ-2a or MRZ-2b (referred to hereafter as MRZ-2) are considered important mineral resource areas.

Local Laws, Regulations, and Policies

El Dorado County in general is considered a mining region capable of producing a wide variety of mineral resources. Metallic mineral deposits, including gold, are considered the most significant extractive mineral resources. El Dorado County identifies mineral resource areas by designating specific locations as a Mineral Resource (-MR) overlay area. The -MR overlay areas are based on mineral resource mapping published in the mineral land classification reports referenced above. The majority of the county’s important mineral resource deposits are concentrated in the western third of the county.

According to General Plan Policy 2.2.2.7, before authorizing any land uses within the -MR overlay zone that will threaten the potential to extract minerals in the affected area, the County shall prepare a statement specifying its reasons for considering approval of the proposed land use and shall provide for public and agency notice of such a statement consistent with the requirements of Public Resources Code section 2762. Furthermore, before finally approving any such proposed land use, the County shall balance the mineral values of the threatened mineral resource area against the economic, social, or other values associated with the proposed alternative land uses. Where the affected minerals are of regional significance, the County shall consider the importance of these minerals to their market region as a whole and not just their importance to the County.

Where the affected minerals are of Statewide significance, the County shall consider the importance of these minerals to the State and Nation as a whole. The County may approve the alternative land use if it determines that the benefits of such uses outweigh the potential or certain loss of the affected mineral resources in the affected regional, Statewide, or national market.

APPLICABLE THRESHOLDS OF SIGNIFICANCE:

The list of mineral resource effects that may be considered significant contained in Appendix G of the CEQA Guidelines (Environmental Checklist) was used to establish a threshold of significance.

ENVIRONMENTAL STUDIES PERFORMED AND METHODOLOGY:

Based on the lack of mineral resources in or near the project site, no environmental studies relating to mineral resources were prepared for the proposed project.

IMPACT ANALYSES AND CONCLUSIONS:

A substantial adverse effect on Mineral Resources would occur if the implementation of the project would:

- Result in obstruction of access to, and extraction of mineral resources classified MRZ-2x, or result in land use compatibility conflicts with mineral extraction operations.

a.-b. **Mineral Resources.** The project site has not been delineated in the El Dorado County General Plan as a locally important mineral resource recovery site. Review of the California Department of Conservation Geologic Map data also showed that the project site is not within a mineral resource zone district. There would be **no impact**.

FINDING: No impacts to mineral resources are expected either directly or indirectly with implementation of the proposed project and there would be **no impacts**.

13. NOISE				
Would the project:	Potentially Significant Impact	Less Than Significant with Mitigation	Less Than Significant Impact	No Impact
a) Generation of a substantial temporary or permanent increase in ambient noise levels in the vicinity of the project in excess of standards established in the local general plan or noise ordinance, or applicable standards of other agencies?	<input type="checkbox"/>	<input checked="" type="checkbox"/>	<input type="checkbox"/>	<input type="checkbox"/>
b) Generation of excessive groundborne vibration or groundborne noise levels?	<input type="checkbox"/>	<input type="checkbox"/>	<input checked="" type="checkbox"/>	<input type="checkbox"/>
c) For a project located within the vicinity of a private airstrip or an airport land use plan or, where such a plan has not been adopted, within two miles of a public airport or public use airport, would the project expose people residing or working in the project area to excessive noise levels?	<input type="checkbox"/>	<input type="checkbox"/>	<input type="checkbox"/>	<input checked="" type="checkbox"/>

ENVIRONMENTAL SETTING (BASELINE):

This section provides an assessment to quantify the existing noise and vibration environments, identify potential noise and vibration impacts resulting from the project, identify appropriate mitigation measures, and provide quantitative and qualitative analyses of potential impacts associated with the project.

Noise-Sensitive Land Uses in the Project Vicinity

Noise-sensitive land uses are generally defined as locations where people reside or where the presence of unwanted sound could adversely affect the primary intended use of the land. Places where people live, sleep, recreate, worship, and study are generally considered to be sensitive to noise because intrusive noise can be disruptive to these activities.

The noise-sensitive land uses which would potentially be affected by the project consist of residential and church uses to the north and west. Existing public facilities and commercial uses are located to the north and east of the project site (respectively), which are typically not considered to be noise sensitive.

Existing Overall Ambient Noise Environment at the Project Site

The existing ambient noise environment at the project site is defined primarily by noise from traffic on Greenwood Lane and Highway 50.

REGULATORY SETTING:

Federal Laws, Regulations, and Policies

There are no federal noise or vibration criteria which would be directly applicable to the project.

State Laws, Regulations, and Policies

There are no state noise or vibration criteria which would be directly applicable to the project.

Local Laws, Regulations, and Policies

El Dorado County General Plan

The Public Health, Safety, and Noise Element of the El Dorado County General Plan contains the County's noise-related policies. The specific policies which are generally applicable to the Project include:

Policy 6.5.1.1 Where noise-sensitive land uses are proposed in areas exposed to existing or projected exterior noise levels exceeding the levels specified in Table 3 (General Plan Table 6-1) or the performance standards of Table 4 (General Plan Table 6-2), an acoustical analysis shall be required as part of the environmental review process so that noise mitigation may be included in the project design.

Policy 6.5.1.2 Where proposed non-residential land uses are likely to produce noise levels exceeding the performance standards of Table 4 at existing or planned noise-sensitive uses, an acoustical analysis shall be required as part of the environmental review process so that noise mitigation may be included in the project design.

Policy 6.5.1.3 Where noise mitigation measures are required to achieve the standards of Tables 3 and Table 4, the emphasis of such measures shall be placed upon site planning and project design. The use of noise barriers shall be considered a means of achieving the noise standards only after all other practical design-related noise mitigation measures have been integrated into the project and the noise barriers are not incompatible with the surroundings.

Policy 6.5.1.7 Noise created by new proposed non-transportation noise sources shall be mitigated so as not to exceed the noise level standards of Table 4 for noise-sensitive uses.

Policy 6.5.1.8 New development of noise sensitive land uses will not be permitted in areas exposed to existing or projected levels of noise from transportation noise sources which exceed the levels specified in Table 3 unless the project design includes effective mitigation measures to reduce exterior noise and noise levels in interior spaces to the levels specified in Table 3.

Policy 6.5.1.9 Noise created by new transportation noise sources, excluding airport expansion but including roadway improvement projects, shall be mitigated so as not to exceed the levels specified in Table 3 at existing noise-sensitive land uses.

Policy 6.5.1.11 The standards outlined in Tables 5, 6 and 7 (General Plan Tables 6-3, 6-4, 6-5) shall not apply to those activities associated with actual construction of a project as long as such construction occurs between the hours of 7:00 a.m. and 7:00 p.m., Monday through Friday, and 8:00 a.m. and 5:00 p.m. on weekends, and on federally-recognized holidays. Further, the standards outlined in Tables 5 through 7 shall not apply to public projects to alleviate traffic congestion and safety hazards.

Policy 6.5.1.12 When determining the significance of impacts and appropriate mitigation for new development projects, the following criteria shall be taken into consideration:

- a) Where existing or projected future traffic noise levels are less than 60 dB Ldn at the outdoor activity areas of residential uses, an increase of more than 5 dBA Ldn caused by a new transportation noise source will be considered significant.
- b) Where existing or projected future traffic noise levels range between 60 and 65 dBA Ldn at the outdoor activity areas of residential uses, an increase of more than 3 dBA Ldn caused by a new transportation noise source will be considered significant; and
- c) Where existing or projected future traffic noise levels are greater than 65 dBA Ldn at the outdoor activity areas of residential uses, an increase of more than 1.5 dBA Ldn caused by a new transportation noise source will be considered significant.

Policy 6.5.1.13 When determining the significance of impacts and appropriate mitigation for new development projects, the following criteria shall be taken into consideration:

- a) In areas in which ambient noise levels are in accordance with the standards in Table 4, increases in ambient noise levels caused by new non-transportation noise sources that exceed 5 dBA shall be considered significant; and
- b) In areas in which ambient noise levels are not in accordance with the standards in Table 4, increases in ambient noise levels caused by new non-transportation noise sources that exceed 3 dBA shall be considered significant.

According to Figure LU-1 of the El Dorado County General Plan (Land Use Diagram), the Project site and adjacent properties are located within a community region of the county. As a result, the noise level limits and associated criteria applicable to community regions identified in the General Plan (Tables 6-1, 6-2, and 6-3) would be applicable to the Project.

APPLICABLE THRESHOLDS OF SIGNIFICANCE:

The noise effects that may be considered significant contained in Appendix G of the CEQA Guidelines (Environmental Checklist) was used to establish a threshold of significance. In addition, the following criteria based on standards established by the California Department of Transportation (Caltrans) and El Dorado County General Plan were used to evaluate the significance of environmental noise and vibration resulting from the project:

- A significant noise impact would be identified if the project would expose persons to or generate noise levels that would exceed applicable noise standards presented in the El Dorado County General Plan.
- A significant impact would be identified if off-site traffic noise exposure or on-site activities generated by the project would substantially increase noise levels at existing sensitive receptors in the vicinity. A substantial increase would be identified relative to the noise level increase significance criteria established in Policies 6.5.1.12 (transportation noise sources) and 6.2.1.13 (non-transportation noise sources) of the El Dorado County General Plan.
- A significant impact would be identified if project construction activities or proposed onsite operations would expose noise-sensitive receptors to excessive groundborne vibration levels. Specifically, an impact would be identified if groundborne vibration levels due to these sources would exceed the Caltrans vibration impact criteria.

ENVIRONMENTAL STUDIES PERFORMED AND METHODOLOGY:

A site-specific noise assessment was not prepared for the project because the proposed residential development is not anticipated cause a substantial increase in ambient noise or vibration levels at any existing sensitive uses in the project vicinity.

IMPACT ANALYSES AND CONCLUSIONS:

a. Noise Exposures:

Off-Site Noise Impacts Associated with Proposed On-Site Activities

The project will construct five duplexes on ten lots which would be substantially similar to existing adjacent residential uses. In addition, there are commercial uses to the north and east. Activities associated with the proposed residential land uses would not generate any substantial temporary or permanent noises beyond those currently experienced in the project area (e.g., apartment complexes to the south). It is acknowledged that the Camerado Springs Middle School is located adjacent to the project site to the west and is considered a noise sensitive land use. Overall, the proposed residential uses, in general, will not involve activities that have the ability to generate noise that exceed standards established in the local general plan or noise ordinance, or applicable standards of other agencies.

Project Construction Noise Levels at Existing Sensitive Uses

During project construction, heavy equipment would be used for grading excavation, paving, and building construction, which would increase ambient noise levels when in use. Noise levels would vary depending on the type of equipment used, how it is operated, and how well it is maintained. Noise exposure at any single point outside a work area may also vary depending upon the proximity of equipment activities to that point. The property lines of the nearest residential uses are located approximately 10 feet from where construction activities would occur on the Project site.

Based on the equipment noise levels, worst-case on-site project construction equipment noise levels at the property lines of the adjacent residential uses located 10 feet away in distance are expected to range from approximately 90 to 99 dBA. Therefore, it is possible that a portion of the Project-related construction equipment could result in substantial short-term increases over ambient maximum noise levels at the nearest existing sensitive uses. Further, it is possible that those noise levels could exceed the applicable El Dorado County General Plan noise level limits applicable to construction noise.

As identified in the Regulatory Setting Section of this report, Policy 6.5.1.11 of the El Dorado County General Plan exempts noise sources associated with construction provided such activities take place between the hours of 7:00 a.m. and 7:00 p.m., Monday through Friday, and 8:00 a.m. and 5:00 p.m. on weekends, and on federally recognized holidays. Noise generated during construction activities would be exempt during these hours and days and this impact would be considered less than significant.

However, if construction activities occur during the hours not exempted by General Plan Policy 6.5.1.11, noise levels generated by construction activities would likely exceed the maximum allowable noise level standards at the adjacent residential uses. As a result, a mitigation measure has been introduced to limit any construction activities to the hours of 7:00 a.m. and 7:00 p.m., Monday through Friday, and 8:00 a.m. and 5:00 p.m. on weekends, and on federally recognized holidays. With incorporation of this mitigation measure, noise impacts associated with construction activities would be considered **less than significant**.

Mitigation Measure for Construction Noise:

Mitigation Measure NOISE-1

Construction activities shall not occur outside the hours of 7:00 a.m. and 7:00 p.m., Monday through Friday, or outside the hours of 8:00 a.m. and 5:00 p.m. on weekends, or at all on federally recognized holidays. The project applicant or construction contractor shall post a publicly visible sign at the entrance to the project site listing the allowable construction hours and the contact information, including telephone numbers, to report noise violations to the County and the contractor. The County shall verify inclusion of the posted signage, by being provided proof of posting by the applicant/construction contractor, prior to commencement of construction of the project. This measure shall also be a note in the building permit plans.

Monitoring Requirement: The developer/ applicant shall be responsible for ensuring implementation of Mitigation Measure NOISE-1. Mitigation Measure NOISE-1 shall be incorporated into all project Improvement Plans including, but not limited to, being included as a note on the plans, which shall be subject to review and approval by the Planning Department.

Monitoring/Enforcement: El Dorado County Planning Services.

b. Groundborne Shaking:

During project construction, heavy equipment would be used for grading, excavation, paving, and building construction, which would generate localized vibration in the immediate vicinity of construction activities. The nearest existing sensitive structures (adjacent residences to the south) are located approximately 20 feet from construction activities that would occur on the project site.

Vibration levels generated from on-site construction activities at the nearest existing residence are predicted to be below the strictest Caltrans thresholds for damage to residential structures of 0.30 in/sec PPV. In addition, the predicted vibration levels are below the threshold for a severe human response as defined by Caltrans (vibration damage potential threshold criteria). Therefore, on-site construction activities at the Project site are not expected to result in excessive groundborne vibration levels at nearby existing residential uses.

Vibration levels generated by construction activities are expected to satisfy the applicable Caltrans groundborne impact vibration criteria and this impact is considered **less than significant**.

c. **Aircraft Noise:**

The project site is located approximately 9,000 feet (1.75 mile) to the southwest of Cameron Airpark which is considered a public airport. According to the Safety Factors Map identified in the Cameron Airpark Airport Land Use Compatibility Plan, the project site is not geographically located within the Airport Influence Area and is outside of established airport Safety Zones. In addition, the Airport Noise Zones Policy Map shows that the project site is located outside of the 55-60 dB CNEL noise contour.

Based on the information above, the results from the ambient noise level survey at the project site, and after consideration of the exterior to interior noise level reduction achieved within standard building construction (at least 25 dB with windows closed and approximately 15 dB with windows open), noise generated from normal aircraft operations at the Cameron Airpark is not predicted to exceed the applicable El Dorado County General Plan exterior or interior noise level criteria at the proposed development. For these reasons, this impact is considered **less than significant**.

FINDING: Implementation of noise-reduction methods during project construction activities (Mitigation Measure NOISE-1) would also result in the satisfaction of the applicable General Plan noise level limits generated by construction activities at the nearest existing residential uses to the south of the Project site. With implementation of the recommended mitigation measure, no significant direct or indirect impacts to noise levels are expected either directly or indirectly from the Project. Impacts would be reduced to a **less-than-significant** level.

14. POPULATION AND HOUSING				
Would the project:	Potentially Significant Impact	Less Than Significant with Mitigation	Less Than Significant Impact	No Impact
a) Induce substantial unplanned population growth in an area, either directly (for example, by proposing new homes and businesses) or indirectly (for example, through extension of roads or other infrastructure)?	<input type="checkbox"/>	<input type="checkbox"/>	<input checked="" type="checkbox"/>	<input type="checkbox"/>
b) Displace substantial numbers of existing people or housing, necessitating the construction of replacement housing elsewhere?	<input type="checkbox"/>	<input type="checkbox"/>	<input type="checkbox"/>	<input checked="" type="checkbox"/>

ENVIRONMENTAL SETTING (BASELINE):

The El Dorado General Plan designates the land use of the project site as residential. The project site is currently undeveloped land. The project site is surrounded by residential, commercial, and public uses (i.e., school).

REGULATORY SETTING:

No federal or state laws, regulations, or policies apply to population and housing and the proposed project.

APPLICABLE THRESHOLDS OF SIGNIFICANCE:

The list of population and housing resource effects that may be considered significant contained in Appendix G of the CEQA Guidelines (Environmental Checklist) was used to establish a threshold of significance.

ENVIRONMENTAL STUDIES PERFORMED AND METHODOLOGY:

Based on the less than significant impact of the project to population and housing, no environmental studies relating to population and housing were prepared for the project.

IMPACT ANALYSES AND CONCLUSIONS:

- a. **Unplanned Population Growth:** The project site has a General Plan land use designation of residential and is zoned for Multi-Unit Residential within a Design Review Combining Zone (RM-DC). The purpose of the Multi-Unit Residential zone is to regulate “lands which are most capable of supporting the highest density of development within the County, based on topography, infrastructure, and circulation availabilities and constraints, as well as proximity to employment centers, public facilities, recreation, and shopping. It is applied to regulate and promote the development of multi-unit dwellings, including apartments, condominiums, and townhouses, while ensuring compatibility with surrounding lower density residential neighborhoods.” The proposed residential uses are allowed uses within the proposed RM-PD zone, is consistent with the residential General Plan land use designation, and would be compatible with the existing, surrounding development. For these reasons, the project would not induce unplanned population growth and impacts are considered **less than significant**.
- b. **Housing Displacement:** The project site is currently devoid of any development and no housing would be displaced by implementation of the project. Similarly, the project would not have the ability to displace substantial numbers of people, necessitating construction of replacement housing elsewhere. For these reasons, the project would not displace substantial numbers of existing people or housing and there would be **no impact**.

FINDING: The project would not induce substantial unplanned population growth and would not displace housing substantial numbers of people necessitating construction of replacement house.

15. PUBLIC SERVICES				
Would the project result in substantial adverse physical impacts associated with the provision of new or physically altered governmental facilities, need for new or physically altered governmental facilities, the construction of which could cause significant environmental impacts, in order to maintain acceptable service ratios, response times or other performance objectives for any of the public services:	Potentially Significant Impact	Less Than Significant with Mitigation	Less Than Significant Impact	No Impact
Fire protection?	<input type="checkbox"/>	<input type="checkbox"/>	<input checked="" type="checkbox"/>	<input type="checkbox"/>
Police protection?	<input type="checkbox"/>	<input type="checkbox"/>	<input checked="" type="checkbox"/>	<input type="checkbox"/>
Schools?	<input type="checkbox"/>	<input type="checkbox"/>	<input checked="" type="checkbox"/>	<input type="checkbox"/>
Parks?	<input type="checkbox"/>	<input type="checkbox"/>	<input checked="" type="checkbox"/>	<input type="checkbox"/>
Other public facilities?	<input type="checkbox"/>	<input type="checkbox"/>	<input checked="" type="checkbox"/>	<input type="checkbox"/>

ENVIRONMENTAL SETTING (BASELINE):

The El Dorado General Plan designates the land use of the project site for multi-unit residential uses. The project site is currently undeveloped land. The project site is surrounded by residential, commercial, and public uses (i.e., school). Christa McAuliffe Park is also located within ¼ mile of the project site.

REGULATORY SETTING:

Federal Laws, Regulations, and Policies

California Fire Code

The California Fire Code (Title 24 CCR, Part 9) establishes minimum requirements to safeguard public health, safety, and general welfare from the hazards of fire, explosion, or dangerous conditions in new and existing buildings. Chapter 33 of CCR contains requirements for fire safety during construction and demolition.

APPLICABLE THRESHOLDS OF SIGNIFICANCE:

The list of public services resource effects that may be considered significant contained in Appendix G of the CEQA Guidelines (Environmental Checklist) was used to establish a threshold of significance. Specifically, an adverse effect on Public Services would occur if the implementation of the project would:

- Substantially increase or expand the demand for fire protection and emergency medical services without increasing staffing and equipment to meet the Department’s/District’s goal of 1.5 firefighters per 1,000 residents and 2 firefighters per 1,000 residents, respectively;
- Substantially increase or expand the demand for public law enforcement protection without increasing staffing and equipment to maintain the Sheriff’s Department goal of one sworn officer per 1,000 residents;
- Substantially increase the public school student population exceeding current school capacity without also including provisions to adequately accommodate the increased demand in services;

- Place a demand for library services in excess of available resources; or
- Substantially increase the local population without dedicating a minimum of 5 acres of developed parklands for every 1,000 residents.

ENVIRONMENTAL STUDIES PERFORMED AND METHODOLOGY:

Based on the less than significant impact of the project site to public services resources, no environmental studies relating to public services resources were prepared for the project.

IMPACT ANALYSES AND CONCLUSIONS:

- Fire Protection:** The project was distributed to and reviewed by the Cameron Park Fire Department in cooperation with the California Department of Forestry and Fire Protection (CAL FIRE). The Cameron Park Fire Department would review the improvement plans at the time of building permit submittal to verify the project meets required fire flow and fire hydrant locations. With future review of improvement plans at the time of building permit submittal and project compliance with all comments, any potential impacts would remain **less than significant**.
- Police Protection:** Police protection services would be provided by the El Dorado County Sheriff's Office. The Project would not increase the population substantially to create the need for additional law enforcement protection. The project would result in the population increasing by approximately 26 persons (2.59 persons per household x 10 housing units) which accounts for less than 1% of the current population in Cameron Park (18,881 persons) (Census 2022). Therefore, impacts to police protection are considered to be **less than significant**.
- Schools:** The Camerado Springs Middle School is located adjacent to the west of the project site. In addition, the Blue Oak Elementary School is located within ¼ mile of the project site. Even though the residential component of the project would generate some students, the number of students generated by the new development would not increase the school student population substantially thereby exceeding current school capacity and ability to sufficiently provide school services. For these reasons, the project would result in **less than significant** impacts on schools.
- Parks:** Christa McAuliffe Park is located within ¼-mile to the southwest of the project site. The project would not increase the population substantially to create the need for additional parkland. The project would result in the population increasing by approximately 26 persons (2.59 persons per household x 10 housing units) which accounts for less than 1% of the current population in Cameron Park (18,881 persons) (Census 2022). Therefore, the project would not have a substantial adverse impact on parks and impacts are considered to be **less than significant**.
- Government Services:** The project would not increase the population substantially to create the need for additional government services. The project would result in the population increasing by approximately 26 persons (2.59 persons per household x 10 housing units) which accounts for less than 1% of the current population in Cameron Park (18,881 persons) (Census 2022). Therefore, impacts to government services are considered to be **less than significant**.

FINDING: The project would not result in a need for significant increase of public services to serve the future population at the site. Further, any increased demand for public services would be addressed through the payment of established impact fees, if applicable, at time of building permit issuance. Overall, impacts to public services would be **less than significant**.

References Used:

United States Census Bureau, 2022, QuickFacts, Cameron Park CDP, California. Available at: <https://www.census.gov/quickfacts/fact/table/cameronparkcdpcalifornia/PST045221> (Accessed March 11, 2022).

16. RECREATION				
Would the project:	Potentially Significant Impact	Less Than Significant with Mitigation	Less Than Significant Impact	No Impact
a) Would the project increase the use of existing neighborhood and regional parks or other recreational facilities such that substantial physical deterioration of the facility would occur or be accelerated?	<input type="checkbox"/>	<input type="checkbox"/>	<input checked="" type="checkbox"/>	<input type="checkbox"/>
b) Does the project include recreational facilities or require the construction or expansion of recreational facilities which might have an adverse physical effect on the environment?	<input type="checkbox"/>	<input type="checkbox"/>	<input checked="" type="checkbox"/>	<input type="checkbox"/>

ENVIRONMENTAL SETTING (BASELINE):

The El Dorado General Plan designates the land use of the project site for multi-unit residential uses. The project site is currently undeveloped land. The project site is surrounded by residential, commercial, and public uses (i.e., school). Christa McAuliffe Park is also located within ¼ mile of the project site.

REGULATORY SETTING:

National Trails System

The National Trails System Act of 1968 authorized The National Trails System (NTS) in order to provide additional outdoor recreation opportunities and to promote the preservation of access to the outdoor areas and historic resources of the nation. The Appalachian and Pacific Crest National Scenic Trails were the first two components, and the System has grown to include 20 national trails.

The National Trails System includes three classes of trails:

1. National Scenic Trails (NST) provide outdoor recreation and the conservation and enjoyment of significant scenic, historic, natural, or cultural qualities. The Pacific Coast Trail (PCT) falls under this category. The PCT passes through the Desolation Wilderness area along the western plan area boundary.
2. National Historic Trails (NHT) follow travel routes of national historic significance. The National Park Service has designated two National Historic Trail (NHT) alignments that pass through El Dorado County, the California NHT and the Pony Express NHT. The California NHT is a route of approximately 5,700 miles including multiple routes and cutoffs, extending from Independence and Saint Joseph, Missouri, and Council Bluffs, Iowa, to various points in California and Oregon. The Pony Express NHT commemorates the route used to relay mail via horseback from Missouri to California before the advent of the telegraph.
3. National Recreation Trails (NRT) are in, or reasonably accessible to, urban areas on federal, state, or private lands. In El Dorado County there are 5 NRTs.

State Laws, Regulations, and Policies

The California Parklands Act

The California Parklands Act of 1980 (Public Resources Code Section 5096.141-5096.143) recognizes the public interest for the state to acquire, develop, and restore areas for recreation and to aid local governments to do the same. The California Parklands Act also identifies the necessity of local agencies to exercise vigilance to see that the parks,

recreation areas, and recreational facilities they now have are not lost to other uses.

The California state legislature approved the California Recreational Trail Act of 1974 (Public Resources Code Section 2070-5077.8) requiring that the Department of Parks and Recreation prepare a comprehensive plan for California trails. The California Recreational Trails Plan is produced for all California agencies and recreation providers that manage trails. The Plan includes information on the benefits of trails, how to acquire funding, effective stewardship, and how to encourage cooperation among different trail users.

The 1975 Quimby Act (California Government Code Section 66477) requires residential subdivision developers to help mitigate the impacts of property improvements by requiring them to set aside land, donate conservation easements, or pay fees for park improvements. The Quimby Act gave authority for passage of land dedication ordinances to cities and counties for parkland dedication or in-lieu fees paid to the local jurisdiction. Quimby exactions must be roughly proportional and closely tied (nexus) to a project's impacts as identified through traffic studies required by CEQA. The exactions only apply to the acquisition of new parkland; they do not apply to the physical development of new park facilities or associated operations and maintenance costs.

The County implements the Quimby Act through §16.12.090 of the County Code. The County Code sets standards for the acquisition of land for parks and recreational purposes, or payments of fees in lieu thereof, on any land subdivision. Other projects, such as ministerial residential or commercial development, could contribute to the demand for park and recreation facilities without providing land or funding for such facilities.

Local Laws, Regulations, and Policies

The 2015 El Dorado County General Plan Parks and Recreation Element establishes goals and policies that address needs for the provision and maintenance of parks and recreation facilities in the county, with a focus on providing recreational opportunities and facilities on a regional scale, securing adequate funding sources, and increasing tourism and recreation-based businesses. The Recreation Element describes the need for 1.5 acres of regional parkland, 1.5 acres of community parkland, and 2 acres of neighborhood parkland per 1,000 residents. Another 95 acres of park land are needed to meet the General Plan guidelines.

APPLICABLE THRESHOLDS OF SIGNIFICANCE:

The list of recreational resource effects that may be considered significant contained in Appendix G of the CEQA Guidelines (Environmental Checklist) was used to establish a threshold of significance. Specifically, a substantial adverse effect on recreational resources would occur if the implementation of the project would:

- Substantially increase the local population without dedicating a minimum of 5 acres of developed parklands for every 1,000 residents; or
- Substantially increase the use of neighborhood or regional parks in the area such that substantial physical deterioration of the facility would occur.

ENVIRONMENTAL STUDIES PERFORMED AND METHODOLOGY:

Based on the less than significant impact of the project site to recreational resources, no environmental studies relating to recreational resources were prepared for the project.

IMPACT ANALYSES AND CONCLUSIONS:

- a. **Parks:** Christa McAuliffe Park is located within ¼-mile to the southwest of the project site. The project would not increase the population substantially to increase the use of existing neighborhood and regional parks or other recreational facilities such that substantial physical deterioration of the facility would occur or be accelerated. The project would result in the population increasing by approximately 26 persons (2.59 persons per household x 10 housing units) which accounts for less than 1% of the current population in Cameron Park (18,881 persons) (Census 2022). Therefore, the project would not have a substantial adverse impact on neighborhood or regional parks and impacts are considered to be **less than significant**.

- b. **Recreational Services:** The project would not increase the population substantially require the construction or expansion of recreational facilities which might have an adverse physical effect on the environment. The project would result in the population increasing by approximately 26 persons (2.59 persons per household x 10 housing units) which accounts for less than 1% of the current population in Cameron Park (18,881 persons) (Census 2022). In addition, the project does not include any recreational facilities in itself. Therefore, the project would not have a substantial adverse impact on recreational services and impacts are considered to be **less than significant**.

FINDING: The project would result in a **less-than-significant** impact to neighborhood and regional parks and to recreational facilities.

References Used:

United States Census Bureau, 2022, QuickFacts, Cameron Park CDP, California. Available at: <https://www.census.gov/quickfacts/fact/table/cameronparkcdpcalifornia/PST045221> (Accessed March 11, 2022).

17. TRANSPORTATION				
Would the project:	Potentially Significant Impact	Less Than Significant with Mitigation	Less Than Significant Impact	No Impact
a) Conflict with a program, plan, ordinance, or policy addressing the circulation system, including transit, roadway, bicycle and pedestrian facilities?	<input type="checkbox"/>	<input type="checkbox"/>	<input checked="" type="checkbox"/>	<input type="checkbox"/>
b) Would the project conflict or be inconsistent with CEQA Guidelines section 15064.3, subdivision (b)?	<input type="checkbox"/>	<input type="checkbox"/>	<input checked="" type="checkbox"/>	<input type="checkbox"/>
c) Substantially increase hazards due to a geometric design feature (e.g., sharp curves or dangerous intersections) or incompatible uses (e.g., farm equipment)?	<input type="checkbox"/>	<input type="checkbox"/>	<input checked="" type="checkbox"/>	<input type="checkbox"/>
d) Result in inadequate emergency access?	<input type="checkbox"/>	<input type="checkbox"/>	<input checked="" type="checkbox"/>	<input type="checkbox"/>

ENVIRONMENTAL SETTING (BASELINE):

This section provides an assessment of potential impacts to traffic operations associated with the project. The project will construct residential duplexes on a currently undeveloped site located along Greenwood Lane between Meadow Lane and Merrychase Drive in Cameron Park. Access to the project site would be provided at one driveway on Greenwood Lane (Attachment F).

Project Area Roadways

The following are descriptions of the primary roadways in the vicinity of the project site.

US Route 50 (US-50) is an east-west freeway located south of the project site. Generally, US-50 serves all of El Dorado County’s major population centers and provides connections to Sacramento County to the west and the State of Nevada to the east. Primary access to the project site from US-50 is provided at the Cameron Park Drive interchange. Within the general project area, US-50 currently serves approximately 55,000 vehicles per day (vpd) west of Cameron Park Drive.

Greenwood Lane is a north-south collector roadway connecting Merrychase Drive on the south with Knollwood Drive on the north. The project site will take access from one driveway along Greenwood Lane.

Merrychase Lane is an east-south collector roadway connecting Cambridge Road on the east with Country Club Drive on the west.

REGULATORY SETTING:

Federal Laws, Regulations, and Policies

No federal laws, regulations, or policies apply to transportation/traffic and the proposed project.

State Laws, Regulations, and Policies

Caltrans manages the state highway system and ramp interchange intersections. This state agency is also responsible for highway, bridge, and rail transportation planning, construction, and maintenance.

Local Laws, Regulations, and Policies

The Transportation and Circulation Element of the County General Plan relies on automobile delay and Level of Service (LOS) as performance measures to determine impacts on County-maintained roads and state highways within the unincorporated areas of the county.

County General Plan Policy TC-Xd states that LOS for County-maintained roads and state highways within the unincorporated areas of the county shall not be worse than LOS E in the Community Regions or LOS D in the Rural Centers and Rural Regions. Level of Service is calculated using the methodologies in the latest edition of the Highway Capacity Manual (Transportation Research Board, National Research Council). There are some roadway segments that are except from these standards and are allowed to operate at LOS F and are listed in the General Plan (Table TC-2). According to Policy TC-Xe, “worsen” is defined as any of the following number of project trips using a road facility at the time of issuance of a use and occupancy permit for the development project:

- A. A two percent increase in traffic during a.m., p.m. peak hour, or daily
- B. The addition of 100 or more daily trips, or
- C. The addition of 10 or more trips during the a.m. or p.m. peak hour.

Automobile delay and LOS may no longer be used as the performance measure to determine the transportation impacts of land development under CEQA. Instead, an alternative metric that supports the goals of SB 743 legislation will be required. The use of vehicle miles traveled (VMT) has been recommended by OPR and is cited in the CEQA Guidelines as the most appropriate measure of transportation impacts (Section 15064.3(a)).

The intent of SB743 is to bring CEQA transportation analysis into closer alignment with other statewide policies regarding greenhouse gases, complete streets, and smart growth. Using VMT as a performance measure, instead of LOS, is intended to discourage suburban sprawl, reduce greenhouse gas emissions, and encourage the development of smart growth, complete streets, and multimodal transportation networks.

Current direction regarding methods to identify VMT and comply with state requirements is provided by OPR December 2018 publication, Technical Advisory on Evaluating Transportation Impacts in CEQA. This advisory contains technical recommendations regarding assessment of VMT, thresholds of significance, and mitigation measures. OPR provides this Technical Advisory as a resource for the public to use at their discretion. OPR is not enforcing or attempting to enforce any part of the recommendations contained herein. (Government Code Section 65035 [“It is not the intent of the Legislature to vest in the Office of Planning and Research any direct operating or regulatory powers over land use, public works, or other state, regional, or local projects or programs.”].)

OPR’s Technical Advisory provides the following direction for small projects:

Many local agencies have developed screening thresholds to indicate when detailed analysis is needed. Absent substantial evidence indicating that a project would generate a potentially significant level of VMT, or inconsistency with a Sustainable Communities Strategy (SCS) or general plan, projects that generate or attract fewer than 110 trips per day generally may be assumed to cause a less-than-significant transportation impact.

On October 6, 2020, El Dorado County Board of Supervisors adopted Resolution 141-2020 setting thresholds of significance for VMT resulting from proposed development projects. The VMT threshold for residential is 15% below baseline unincorporated countywide VMT per capita (unincorporated County average is currently 22.5 VMT per capita with a threshold of 19.1 VMT per capita).

APPLICABLE THRESHOLDS OF SIGNIFICANCE:

The effects to traffic that may be considered significant contained in Appendix G of the CEQA Guidelines (Environmental Checklist) was used to establish a threshold of significance. Specifically, a substantial adverse effect on Transportation would occur if the implementation of the project would:

- Conflict with an applicable program, plan, ordinance or policy addressing the circulation system, including transit, roadway, bicycle and pedestrian facilities;
- Conflict or be inconsistent with CEQA Guidelines section 15064.3, subdivision (b) (Vehicle Miles Traveled); or
- Substantially increase hazards due to a geometric design feature (e.g., sharp curves or dangerous intersections) or incompatible uses (e.g., farm equipment); or
- Result in inadequate emergency access.

ENVIRONMENTAL STUDIES PERFORMED AND METHODOLOGY:

A site-specific transportation study was not prepared for the project. The project was determined by the County Department of Transportation (DOT) to not require a Transportation Impact Study because the project would generate less than 10 trips during a peak hour and less than 100 daily trips. As such, DOT issued a waiver.

IMPACT ANALYSES AND CONCLUSIONS:

a. Conflicts with a Transportation Plan, Policy or Ordinance:

Roadway Facilities

The project is estimated to generate 73 new daily trips, 5 new trips during the a.m. peak-hour, and 6 new trips during the p.m. peak-hour. The project was determined to not worsen road facility operations (as defined by Policy TC-Xe of the El Dorado County General Plan) because it would not increase traffic during the a.m. peak hour, p.m. peak hour, or daily by two percent; would not add 100 or more daily trips; or add 1 or more trips during the a.m. peak hour or p.m. peak hour. In addition, the project applicant is required to pay Traffic Impact Mitigation (TIM) fees which would go to funding the needed roadway improvements, installation of a traffic signal as an example, in the Cameron Park area.

Transit, Bicycle, and Pedestrian Facilities

El Dorado Transit operates *Bus Route 40: Cameron Park/Shingle Springs* along Greenwood Lane, Knollwood Drive, and Merrychase Drive in the vicinity of the project site. The closest stop is approximately 200 feet north of the project site, at the intersection of Greenwood Lane and Meadow Lane. Route 40 provides hourly service from 6:25 AM to 6:25 PM, providing transfers to the 50 Express and Sacramento Commuter routes. The project would not result in any conflict or impediment to the operation of El Dorado Transit operations along Greenwood Lane.

A Class II bike lane extends along Greenwood Lane in the vicinity of the project site. The Project would not result in removal of the existing bike lane. The project would be required to construct on-site roadway and pedestrian facilities in accordance with County design guidelines. These on-site pedestrian and bicycle facilities would connect the project site with the existing adjacent Class II bike lanes along Greenwood Lane. Through this connection to the existing bike lane network, the project would provide continuity with adjacent projects, schools, parks, and other public facilities.

For these reasons discussed above, the project would not conflict with a program plan, ordinance or policy addressing the circulation system. Impacts are considered to be **less than significant**.

- b. **Vehicle Miles Travelled (VMT):** A project-specific analysis of its compliance with SB 743 was not completed. For the purposes of SB 743 analysis and the determination of transportation related significant impacts, residential uses were analyzed.

Consistent with Resolution 141-20201, for residential, the El Dorado County Travel Demand Model (TDM) was used as the principal tool to determine VMT. The TDM contains a base year of 2018 and future year of 2040, but only the base year version of the model was used to determine the VMT impact of the proposed residential land uses. In addition, the TDM was recently updated to include a VMT analysis tool, which was used to complete the

analysis of the Project. The VMT estimation tool generates estimates in a manner that is consistent with OPR's guidelines. In addition, to provide a full accounting of vehicle travel, the TDM provides VMT estimates that include the VMT from intrazonal vehicle trips and trip length adjustments for the trips that enter or exit the area covered by the TDM.

El Dorado County has recently adopted VMT thresholds and analysis guidelines that were used as the basis of the VMT analysis. Based on the County adopted guidelines and thresholds, a project is considered to result in a significant impact if the VMT per capita or VMT per employee for a project exceeds 85-percent of the County average. Specifically, the County's VMT thresholds of significance include the following components:

- Residential – 15% below baseline unincorporated countywide VMT per capita (unincorporated County average is currently 22.5 VMT per capita with a threshold of 19.1 VMT per capita)
- Commercial Office – 15% below baseline unincorporated countywide VMT per employee (unincorporated County average is currently 12.8 VMT per employee with a threshold of 10.8 VMT per employee)
- Commercial Retail – No net increase in VMT (unincorporated County total is 3,606,897 VMT)

To determine the project's potential VMT, this analysis utilized assumptions used in the CalEEMod model which provides VMT based on a project's characteristics (e.g., size, number of units) and geographic location. The CalEEMod model determined the proposed project would generate 17.5 VMT and the proposed residential land uses would result in a VMT per capita below the County's threshold at 22% (calculated by $(1 - (17.5 \text{ project VMT} / 22.5 \text{ VMT per capita}))$). Therefore, the project would comply with El Dorado County Resolution 141-2020 which set thresholds of significance for VMT resulting from proposed development projects. Impacts related to VMT are considered **less than significant**.

c. **Design Hazards:** The design and location of the project are not anticipated to create any significant hazards. As previously identified, access to the Project site would be provided at one driveway along Greenwood Lane. As part of the County DOT's review of and determination that the project would not require a Transportation Impact Study also required the DOT's evaluation of the following components of the project:

- existing traffic problems in the project area,
- proximity of proposed,
- adequacy of vehicle parking,
- adequacy of project design to satisfy truck circulation,
- adequacy of the project design to provide at least 25-foot minimum required throat depth at project driveways,
- adequacy of project site design to convey all vehicle types, and
- adequacy of sight distance on-site.

Based on the County's issuance of a waiver because the project would generate less than 10 trips during a peak hour and less than 100 daily trips, it is assumed that the project design would not substantially increase hazards due to a geometric design feature or incompatible uses. For these reasons, impacts related to design hazards are considered **less than significant**.

d. **Emergency Access:** The project site would include access to all five duplexes and accommodates fire access as required by the County's *Fire Safe Regulations* that require on-site roadways to "provide for safe access for emergency wildland fire equipment and civilian evacuation concurrently, and shall provide unobstructed traffic circulation during a wildfire emergency..." The Cameron Park Fire Department reviewed the proposed project site plan, including the proposed fire apparatus access road, and would review the improvement plans at time of building permit submittal to ensure compliance with all safety protocols. For these reasons, impacts related to emergency access are considered **less than significant**.

FINDING: The project would not conflict with applicable General Plan policies regarding effective operation of the County circulation system and the project would not exceed the level of service thresholds for traffic identified within the General Plan. Further, the project would not conflict or be inconsistent with CEQA Guidelines Section 15064.3(b)

(VMT). Lastly, the project would not create any road hazards or affect road safety and would not result in inadequate emergency access. Overall, the thresholds of significance established for transportation impacts would not be exceeded with implementation of the project and impacts would be **less than significant**.

18. TRIBAL CULTURAL RESOURCES				
<p>Conducting consultation early in the CEQA process allows tribal governments, lead agencies, and project proponents to discuss the level of environmental review, identify and address potential adverse impacts to tribal cultural resources, and reduce the potential for delay and conflict in the environmental review process. (See Public Resources Code section 21083.3.2.) Information may also be available from the California Native American Heritage Commission’s Sacred Lands File per Public Resources Code section 5097.96 and the California Historical Resources Information System administered by the California Office of Historic Preservation. Please also note that Public Resources Code section 21082.3(c) contains provisions specific to confidentiality.</p>				
<p>Would the project cause a substantial adverse change in the significance of a tribal cultural resource, defined in Public Resources Code section 21074 as either a site, feature, place, cultural landscape that is geographically defined in terms of the size and scope of the landscape, sacred place, or object with cultural value to a California Native American tribe, and that is:</p>	<p>Potentially Significant Impact</p>	<p>Less Than Significant with Mitigation</p>	<p>Less Than Significant Impact</p>	<p>No Impact</p>
<p>a) Listed or eligible for listing in the California Register of Historical Resources, or in a local register of historical resources as defined in Public Resources Code section 5020.1(k), or</p>	<input type="checkbox"/>	<input checked="" type="checkbox"/>	<input type="checkbox"/>	<input type="checkbox"/>
<p>b) A resource determined by the lead agency, in its discretion and supported by substantial evidence, to be significant pursuant to criteria set forth in subdivision (c) of Public Resources Code Section 5024.1. In applying the criteria set forth in subdivision (c) of Public Resource Code Section 5024.1, the lead agency shall consider the significance of the resource to a California Native American tribe.</p>	<input type="checkbox"/>	<input checked="" type="checkbox"/>	<input type="checkbox"/>	<input type="checkbox"/>

ENVIRONMENTAL SETTING (BASELINE):

This section provides an assessment of potential impacts to cultural resources associated with the project. The project area, archaeologists locate prehistoric-period habitation sites "along streams or on ridges or knolls, especially those with southern exposure." The region surrounding the project site is known as the ethnographic-period territory of the Nisenan, also called the Southern Maidu. The Nisenan maintained permanent settlements along major rivers in the Sacramento Valley and foothills; they also periodically traveled to higher elevations (Attachment 4).

The United Auburn Indian Community (UAIC) is a federally recognized Tribe comprised of both Miwok and Maidu (Nisenan) Tribal members who are traditionally and culturally affiliated with the project area. The Tribe has a deep spiritual, cultural, and physical ties to their ancestral land and are contemporary stewards of their culture and landscapes. The Tribal community represents a continuity and endurance of their ancestors by maintaining their connection to their history and culture. It is the Tribe’s goal to ensure the preservation and continuance of their cultural heritage for current and future generations.

REGULATORY SETTING:

Federal Laws, Regulations, and Policies

No federal laws, regulations, or policies apply to Tribal Cultural Resources (TCRs) and the proposed project.

State Laws, Regulations, and Policies

Assembly Bill (AB) 52

AB 52, which was approved in September 2014 and effective on July 1, 2015, requires that CEQA lead agencies consult with a California Native American tribe that is traditionally and culturally affiliated with the geographic area of a proposed project, if so requested by the tribe. The bill, chaptered in CEQA Section 21084.2, also specifies that a project with an effect that may cause a substantial adverse change in the significance of a tribal cultural resource (TCR) is a project that may have a significant effect on the environment.

Defined in Section 21074(a) of the Public Resources Code, TCRs are:

1. Sites, features, places, cultural landscapes, sacred places and objects with cultural value to a California Native American tribe that are either of the following:
 - a. Included or determined to be eligible for inclusion in the California Register of Historical Resources;
or
 - b. Included in a local register of historical resources as defined in subdivision (k) of Section 5020.1.
2. A resource determined by the lead agency, in its discretion and supported by substantial evidence, to be significant pursuant to criteria set forth in subdivision (c) of Section 5024.1. In applying the criteria set forth in subdivision (c) of Section 5024.1 for the purposes of this paragraph, the lead agency shall consider the significance of the resource to a California Native American tribe.

TCRs are further defined under Section 21074 as follows:

- a. A cultural landscape that meets the criteria of subdivision (a) is a TCR to the extent that the landscape is geographically defined in terms of the size and scope of the landscape; and
- b. A historical resource described in Section 21084.1, a unique archaeological resource as defined in subdivision (g) of Section 21083.2, or a “nonunique archaeological resource” as defined in subdivision (h) of Section 21083.2 may also be a TCR if it conforms with the criteria of subdivision (a).

Mitigation measures for TCRs must be developed in consultation with the affected California Native American tribe pursuant to newly chaptered Section 21080.3.2, or according to Section 21084.3. Section 21084.3 identifies mitigation measures that include avoidance and preservation of TCRs and treating TCRs with culturally appropriate dignity, taking into account the tribal cultural values and meaning of the resource.

APPLICABLE THRESHOLDS OF SIGNIFICANCE:

The effects to TCRs that may be considered significant contained in Appendix G of the CEQA Guidelines (Environmental Checklist) was used to establish a threshold of significance. In general, significant impacts are those that diminish the integrity, research potential, or other characteristics that make a TCR significant or important. To be considered a TCR, a resource must be either (1) listed, or determined to be eligible for listing, on the national, state, or local register of historic resources; or (2) a resource that the lead agency chooses, in its discretion, to treat as a TCR and meets the criteria for listing in the state register of historic resources pursuant to the criteria set forth in Public Resources Code Section 5024.1(c). A substantial adverse change to a TCR would occur if the implementation of the project would:

- Disrupt, alter, or adversely affect a TCR such that the significance of the resource would be materially impaired.

ENVIRONMENTAL STUDIES PERFORMED AND METHODOLOGY:

A complete records search was conducted by searching the California Historic Resources Information System (CHRIS) maps for cultural resource site records and survey reports in El Dorado County within a ¼-mile radius of the project site. The project search area is situated in the Sierra Nevada foothills. Within the search area, the records show

no evidence of nineteenth-century or twentieth-century historical activity. The records search determined that given the extent of known cultural resources, patterns of local history, and the environmental setting, there is low potential for locating prehistoric-period or historic-period cultural resources in the immediate vicinity of the project site.

UAIC conducted a records search for the identification of Tribal Cultural Resources for this project which included a review of pertinent literature and historic maps, and a records search using UAIC's Tribal Historic Information System (THRIS). UAIC's THRIS database is composed of UAIC's areas of oral history, ethnographic history, and places of cultural and religious significance, including UAIC Sacred Lands that are submitted to the Native American Heritage Commission (NAHC). The THRIS resources shown in this region also include previously recorded indigenous resources identified through the California Historic Resources Information System Center (CHRIS) as well as historic resources and survey data.

IMPACT ANALYSES AND CONCLUSIONS:

a-b. **Tribal Cultural Resources:** At the time of the initial review consultation, seven tribes had requested to be notified of proposed projects for consultation in the project area: Wilton Rancheria, Ione Band of Miwok Indians, Nashville Enterprise Miwok-Maidu-Nishinam Tribe, Shingle Springs Band of Miwok Indians, United Auburn Indian Community of the Auburn Rancheria, Washoe Tribe of California and Nevada, and T'si-Akim Maidu. None of the tribes responded with a request for formal consultation. However, the UAIC requested that mitigation measures be provided in the Tribal Cultural Resources analysis for unanticipated discoveries of an unknown tribal cultural resource. An initial records search was conducted by searching CHRIS maps for cultural resource site records and survey reports in El Dorado County within a ¼-mile radius of the project site. It was determined that there is low potential for locating historic-period cultural resources in the immediate vicinity of the project site. It was determined that there is low potential for locating historic-period cultural resources in the immediate vicinity of the proposed project area. Although further archival and/or field study by a tribal cultural resource professional was not recommended, implementing mitigation measure TCR-1 would ensure potential impacts to an undiscovered tribal cultural resource remains at a level of are considered **less than significant**.

Mitigation Measure for Undiscovered Cultural Resources:

Mitigation Measure TCR-1

If any suspected tribal cultural resource (TCR) is discovered during ground disturbing construction activities, all work shall cease within 100 feet of the find, or an agreed upon distance based on the project area and nature of the find. A Tribal Representative from a California Native American tribe that is traditionally and culturally affiliated with a geographic area shall be immediately notified and shall determine if the find is a TCR (PRC §21074). The Tribal Representative will make recommendations for further evaluation and treatment as necessary.

When avoidance is infeasible, preservation in place is the preferred option for mitigation of TCRs under CEQA and tribal protocols, and every effort shall be made to preserve the resources in place, including through project redesign, if feasible. Culturally appropriate treatment may be, but is not limited to, processing materials for reburial, minimizing handling of cultural objects, leaving objects in place within the landscape, or returning objects to a location within the project area where they will not be subject to future impacts. Permanent curation of TCRs will not take place unless approved in writing by the California Native American Tribe that is traditionally and culturally affiliated with the project area.

The contractor shall implement any measures deemed by CEQA lead agency to be necessary and feasible to preserve in place, avoid, or minimize impacts to the resource, including, but not limited to, facilitating the appropriate tribal treatment of the find, as necessary. Treatment that preserves or restores the cultural character and integrity of a TCR may include Tribal Monitoring, culturally appropriate recovery of cultural objects, and reburial of cultural objects or cultural soil.

Work at the discovery location cannot resume until all necessary investigation and evaluation of the discovery under the requirements of CEQA, including AB52, have been satisfied.

Monitoring Requirement: The developer/ applicant shall be responsible for ensuring implementation of Mitigation Measure TCR-1. Mitigation Measure TCR-1 shall be incorporated into all project Improvement Plans including, but not limited to, being included as a note on the plans, which shall be subject to review and approval by the Planning Department.

Monitoring /Enforcement: El Dorado County Planning Services.

FINDING: With the implementation of mitigation measure TCR-1, potential impacts to undiscovered tribal cultural resources with implementation of the project would remain at a **less-than-significant** level.

19. UTILITIES AND SERVICE SYSTEMS				
Would the project:	Potentially Significant Impact	Less Than Significant with Mitigation	Less Than Significant Impact	No Impact
a) Require or result in the relocation or construction of new or expanded water, wastewater treatment or storm water drainage, electric power, natural gas, or telecommunications facilities, the construction or relocation of which could cause significant environmental effects?	<input type="checkbox"/>	<input type="checkbox"/>	<input checked="" type="checkbox"/>	<input type="checkbox"/>
b) Have sufficient water supplies available to serve the project and reasonably foreseeable future development during normal, dry and multiple dry years?	<input type="checkbox"/>	<input type="checkbox"/>	<input checked="" type="checkbox"/>	<input type="checkbox"/>
c) Result in a determination by the wastewater treatment provider which serves or may serve the project that it has adequate capacity to serve the project's projected demand in addition to the provider's existing commitments?	<input type="checkbox"/>	<input type="checkbox"/>	<input checked="" type="checkbox"/>	<input type="checkbox"/>
d) Generate solid waste in excess of State or local standards, or in excess of the capacity of local infrastructure, or otherwise impair the attainment of solid waste reduction goals?	<input type="checkbox"/>	<input type="checkbox"/>	<input checked="" type="checkbox"/>	<input type="checkbox"/>
e) Comply with federal, state, and local management and reduction statutes and regulations related to solid waste?	<input type="checkbox"/>	<input type="checkbox"/>	<input checked="" type="checkbox"/>	<input type="checkbox"/>

ENVIRONMENTAL SETTING (BASELINE):

This section provides an assessment of potential impacts to utility and service systems ability to serve the proposed development with implementation of the project. The El Dorado Irrigation District (EID) provides potable water and sewer service at the project site. El Dorado Disposal provides municipal solid waste service at the project site. Pacific Gas and Electric (PG&E) provides natural gas and electrical service to the project site.

REGULATORY SETTING:

Federal Laws, Regulations, and Policies

No federal laws, regulations, or policies apply to utilities and service systems and the proposed project.

State Laws, Regulations, and Policies

California Integrated Waste Management Act of 1989

The California Integrated Waste Management Act of 1989 (Public Resources Code, Division 30) requires all California cities and counties to implement programs to reduce, recycle, and compost wastes by at least 50 percent by 2000 (Public Resources Code Section 41780). The state, acting through the California Integrated Waste Management

Board (CIWMB), determines compliance with this mandate. Per-capita disposal rates are used to determine whether a jurisdiction's efforts are meeting the intent of the act.

California Solid Waste Reuse and Recycling Access Act of 1991

The California Solid Waste Reuse and Recycling Access Act of 1991 (Public Resources Code Sections 42900-42911) requires that all development projects applying for building permits include adequate, accessible areas for collecting and loading recyclable materials.

Urban Water Management Planning Act

California Water Code Sections 10610 *et seq.* requires that all public water systems providing water for municipal purposes to more than 3,000 customers, or supplying more than 3,000 acre-feet per year (AFY), prepare an urban water management plan (UWMP).

APPLICABLE THRESHOLDS OF SIGNIFICANCE:

The effects to utilities and service systems that may be considered significant contained in Appendix G of the CEQA Guidelines (Environmental Checklist) was used to establish a threshold of significance. A substantial adverse effect on Utilities and Service Systems would occur if the implementation of the project would:

- Breach published national, state, or local standards relating to solid waste or litter control;
- Substantially increase the demand for potable water in excess of available supplies or distribution capacity without also including provisions to adequately accommodate the increased demand, or is unable to provide an adequate on-site water supply, including treatment, storage and distribution;
- Substantially increase the demand for the public collection, treatment, and disposal of wastewater without also including provisions to adequately accommodate the increased demand, or is unable to provide for adequate on-site wastewater system; or
- Result in demand for expansion of power or telecommunications service facilities without also including provisions to adequately accommodate the increased or expanded demand.

ENVIRONMENTAL STUDIES PERFORMED AND METHODOLOGY:

Confirmation of the utility and service providers to adequately serve the proposed project were obtained and reviewed to determine the significance of any potential impacts.

IMPACT ANALYSES AND CONCLUSIONS:

- a. **Construction of New Facilities:** Construction of new facilities on the project site would be required to serve the proposed development. Proposed water lines, sewer lines, and related facilities would be located within an easement and would remain accessible by conventional maintenance vehicles. Easements for any new EID facilities constructed by the project would be granted to EID prior to approval of water and sewer improvements, whether onsite or offsite. For electricity service, the project would require connecting for service with PG&E. PG&E reviewed the project and did not provide any comments. Impacts associated with construction of new facilities are considered **less than significant**.
- b. **Sufficient Water Supply:** The project would be served by public water infrastructure. EID reviewed the project and provided verification of water service. There is an 8-inch water line located in Greenwood Lane adjacent to the project site which has adequate capacity to serve the proposed development. The proposed development would require 9 EDUs of water. A Facilities Improvement Letter (FIL) outlines the specific project site improvements required to serve the proposed development. Proposed water lines and related facilities would be located within an easement and would remain accessible by conventional maintenance vehicles. Easements for any new EID facilities constructed by the project would be granted to EID prior to approval of water improvements, whether onsite or offsite (Attachment F). Further, The Cameron Park Fire Department in cooperation with CAL FIRE,

will review the improvement plans at time of building permit submittal to verify the project meets required fire flow at that time. Impacts to water supplies are considered **less than significant**.

- c. **Wastewater Requirements:** The project will require connecting to public sewer. EID reviewed the project and confirmed service is available. There is an 8-inch sewer line located in Greenwood Lane adjacent to the project site which has adequate capacity to serve the proposed development. In order to receive service from this line, an extension of facilities of adequate size would be constructed on the project site. The project would require 9 EDUs of sewer service. An FIL outlines the specific improvement requirements on the project site. Proposed sewer lines and related facilities would be required to be located within an easement and would remain accessible by conventional maintenance vehicles. Easements for any new EID facilities constructed by the project would be granted to EID prior to approval of sewer improvements, whether onsite or offsite (Attachment F). Impacts to wastewater services are considered **less than significant**.

- d-e. **Solid Waste Disposal and Requirements:** El Dorado Disposal distributes municipal solid waste to Forward Landfill in Stockton and Kiefer Landfill in Sacramento. Pursuant to El Dorado County Environmental Management Solid Waste Division staff, both facilities have sufficient capacity to serve the County. Recyclable materials are distributed to a facility in Benicia and green wastes are sent to a processing facility in Sacramento. County Ordinance No. 4319 requires that new development provide areas for adequate, accessible, and convenient storing, collecting and loading of solid waste and recyclables. The project would be conditioned to meet the requirements set forth by the County Environmental Management Department. With the Project's compliance with County Environmental Management Department requirements, impacts to solid waste would be **less than significant**.

FINDING: No significant utility and service system impacts would be anticipated with implementation of the project, either directly or indirectly. With implementation of the required construction improvements installed according to established protocols, impacts to public utilities would be **less than significant**.

20. WILDFIRE				
If located in or near state responsibility areas or lands classified as very high fire hazard severity zones, would the project:	Potentially Significant Impact	Less Than Significant with Mitigation	Less Than Significant Impact	No Impact
a) Substantially impair an adopted emergency response plan or emergency evacuation plan?	<input type="checkbox"/>	<input type="checkbox"/>	<input checked="" type="checkbox"/>	<input type="checkbox"/>
b) Due to slope, prevailing winds, and other factors, exacerbate wildfire risks, and thereby expose project occupants to, pollutant concentrations from a wildfire or the uncontrolled spread of a wildfire?	<input type="checkbox"/>	<input type="checkbox"/>	<input checked="" type="checkbox"/>	<input type="checkbox"/>
c) Require the installation or maintenance of associated infrastructure (such as roads, fuel breaks, emergency water sources, power lines or other utilities) that may exacerbate fire risk or that may result in temporary or ongoing impacts to the environment?	<input type="checkbox"/>	<input type="checkbox"/>	<input checked="" type="checkbox"/>	<input type="checkbox"/>
d) Expose people or structures to significant risks, including downslope or downstream flooding or landslides, as a result of runoff, post-fire slope instability, or drainage changes?	<input type="checkbox"/>	<input type="checkbox"/>	<input checked="" type="checkbox"/>	<input type="checkbox"/>

ENVIRONMENTAL SETTING (BASELINE):

This section provides an assessment of potential impacts of wildfires at the project site. State Responsibility Areas are boundaries adopted by the Board of Forestry and Fire Protection and are areas where the California Department of Forestry and Fire (CAL FIRE) has a financial responsibility for fire suppression and prevention. Review of the California State Responsibility Area Viewer indicate the proposed project site is not located in a Very High Hazard Severity Zone (VHFHSZ) but is located in a State Responsibility Area. The closest area classified as a VHFHSZ is located approximately 11 miles east of the project site (CAL FIRE 2022).

REGULATORY SETTING:

Federal Laws, Regulations, and Policies

No federal laws, regulations, or policies apply to wildfire and the project.

State Laws, Regulations, and Policies

No state laws, regulations, or policies apply to wildfire and the project.

APPLICABLE THRESHOLDS OF SIGNIFICANCE:

The list of wildfire resource effects that may be considered significant contained in Appendix G of the CEQA Guidelines (Environmental Checklist) was used to establish a threshold of significance.

ENVIRONMENTAL STUDIES PERFORMED AND METHODOLOGY:

Based on the less than significant impacts to wildfire resources in or near the project site, no environmental studies relating to wildfire resources were prepared for the proposed project.

IMPACT ANALYSES AND CONCLUSIONS:

- a. **Emergency Plan.** Please refer to the analysis provided in Section 9(f) of this Initial Study.
- b. **Wildfire risks.** The project site is not located in an area with environmental conditions conducive to wildland fires. Surrounding urban development could serve as a barrier to wildland fires. Greenwood Lane, adjacent to the project site, could also serve as a fire break if ever needed. Operation of construction equipment on the project site during development has the limited potential to spark a fire. However, construction activities would implement BMPs which address fire prevention methods such as:
- restricting vehicles from driving or parking on dry vegetation during fire sensitive times of the year; and
 - wetting dry construction areas before commencing activities, and wetting throughout the day, as appropriate.

Overall, the project site does not contain specific environmental conditions (e.g., slopes, area of high winds) that would exacerbate wildfire risks and, thereby, potentially expose project occupants to pollutant concentrations from a wildfire or the uncontrolled spread of a wildfire. Potential impacts from wildfire risks are considered **less than significant**.

- c. **Infrastructure exacerbating fire risks.** Implementation of the proposed development would require construction of infrastructure onsite that would be connected to existing infrastructure along adjacent roadways (e.g., Greenwood Lane). However, the project would not require installation of needed infrastructure (e.g., roads, fuel breaks, emergency water sources, power lines) beyond the project site boundaries that could result in exacerbating fire risks. Impacts from fire risks from needed infrastructure to serve the project are considered **less than significant**.
- d. **Post-fire risks.** Landslides tend to occur where slopes are steeper with higher relief. The project site is relatively flat with very little relief. The proposed development would not substantially change the existing slope of the project site. In addition, the proposed development would not substantially change the slopes of the project site. For these reasons, implementation of the proposed project would not have the potential to expose people or structures to significant risks, including downslope or downstream flooding or landslides, as a result of runoff, post-fire slope instability, or drainage changes. Impacts from post-fire risks at the project are considered **less than significant**.

FINDING: No significant wildfire risks impacts would be anticipated with implementation of the project, either directly or indirectly. Implementation of BMPs during construction activities would ensure wildfire risks remain **less than significant**.

References Used:

California Department of Forestry and Fire (CAL FIRE), El Dorado County Fire Hazard Severity Zone Maps for State Responsibility Area. Available at: <https://osfm.fire.ca.gov/divisions/community-wildfire-preparedness-and-mitigation/wildland-hazards-building-codes/fire-hazard-severity-zones-maps/> (Accessed January 31, 2022).

21. MANDATORY FINDINGS OF SIGNIFICANCE				
Does the project:	Potentially Significant Impact	Less Than Significant with Mitigation	Less Than Significant Impact	No Impact
a) Have the potential to degrade the quality of the environment, substantially reduce the habitat of a fish or wildlife species, cause a fish or wildlife population to drop below self-sustaining levels, threaten to eliminate a plant or animal community, reduce the number or restrict the range of a rare or endangered plant or animal, or eliminate important examples of the major periods of California history or prehistory?	<input type="checkbox"/>	<input checked="" type="checkbox"/>	<input type="checkbox"/>	<input type="checkbox"/>
b) Have impacts that are individually limited, but cumulatively considerable? ("Cumulatively considerable" means that the incremental effects of a project are considerable when viewed in connection with the effects of past projects, the effects of other current projects, and the effects of probable future projects)?	<input type="checkbox"/>	<input checked="" type="checkbox"/>	<input type="checkbox"/>	<input type="checkbox"/>
c) Have environmental effects which will cause substantial adverse effects on human beings, either directly or indirectly?	<input type="checkbox"/>	<input type="checkbox"/>	<input checked="" type="checkbox"/>	<input type="checkbox"/>

Discussion

- a. No substantial evidence contained in the project record has been found that indicates this project would have the potential to significantly degrade the quality of the environment. As conditioned and mitigated and with adherence to County permit requirements, this project would not have the potential to substantially reduce the habitat of a fish or wildlife species, cause a fish or wildlife population to drop below self-sustaining levels, threaten to eliminate a plant or animal community, reduce the number or restrict the range of a rare or endangered plant or animal, or eliminate important examples of California history or pre-history. Any impacts from the project would be reduced to less than significant due to the design of the project, the required standards that would be implemented prior to issuance of the building permit processes, any required project specific improvements on the property, and the above-discussed mitigations measures to be incorporated into the Project.
- b. Cumulative impacts are defined in Section 15355 of the CEQA Guidelines as two or more individual effects, which when considered together, would be considerable or which would compound or increase other environmental impacts.

The proposed project and site-specific environmental conditions, which have been disclosed in the Project Description and analyzed in Items 1 through 20, show there would be no significant impacts anticipated related to aesthetics, agriculture resources, air quality, energy, geology/soils, greenhouse gas emissions, hazards/hazardous materials, hydrology/water quality, land use/planning, mineral resources, population/housing, public services, recreation, traffic/transportation, utilities/service systems, or wildfires that would combine with similar effects such that the project’s contribution would be cumulatively considerable. Mitigation measures are recommended to reduce potentially significant impacts to a less-than-significant level for biological resources,

cultural resources, tribal cultural resources, and noise impacts. For all categories, a determination of either less than significant impacts with mitigation, less than significant impacts, or no impacts would be anticipated.

As outlined and discussed in this document, as conditioned and with compliance with County Codes, this project is anticipated to have a less than significant project-related environmental effect which would cause substantial adverse effects on human beings, either directly or indirectly. Based on the analysis in this study, it has been determined that the project would have less than significant cumulative impacts with implementation of recommended mitigation measures.

- c. Based on the discussion contained in this document, no potentially significant impacts to human beings are anticipated to occur with respect to potential project impacts. The project would require review and permitting through the County. Adherence to all applicable standards and conditions would be expected to reduce potential impacts to a less than significant level.

FINDINGS: It has been determined that the proposed project would not result in significant environmental impacts. The project would not exceed applicable environmental standards, nor significantly contribute to cumulative environmental impacts.

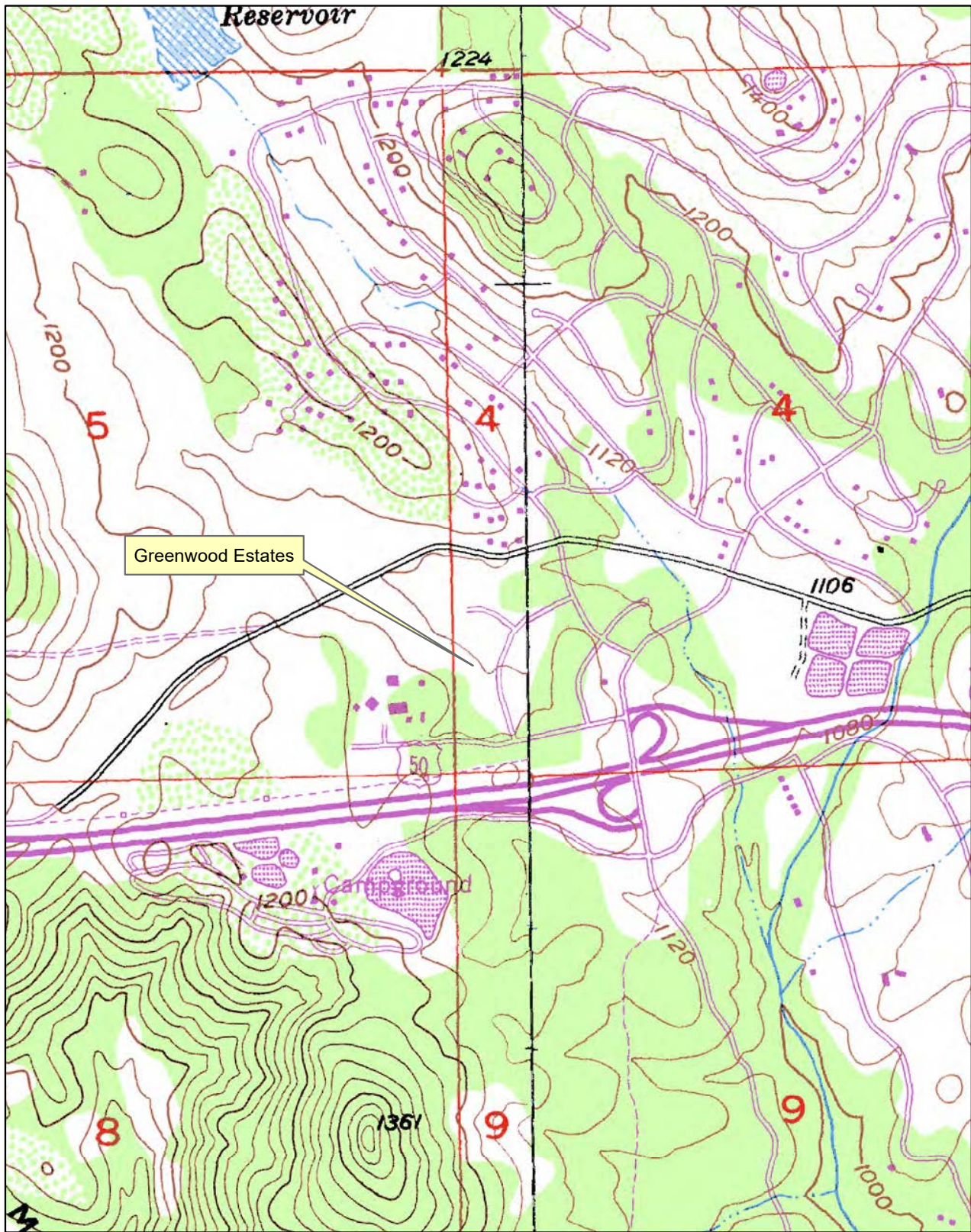

**Z21-0012 PD21-0003 TM21-0001 Greenwood Estates
Attachment A - Location Map**

N



0 0.1 0.2 0.4 Miles

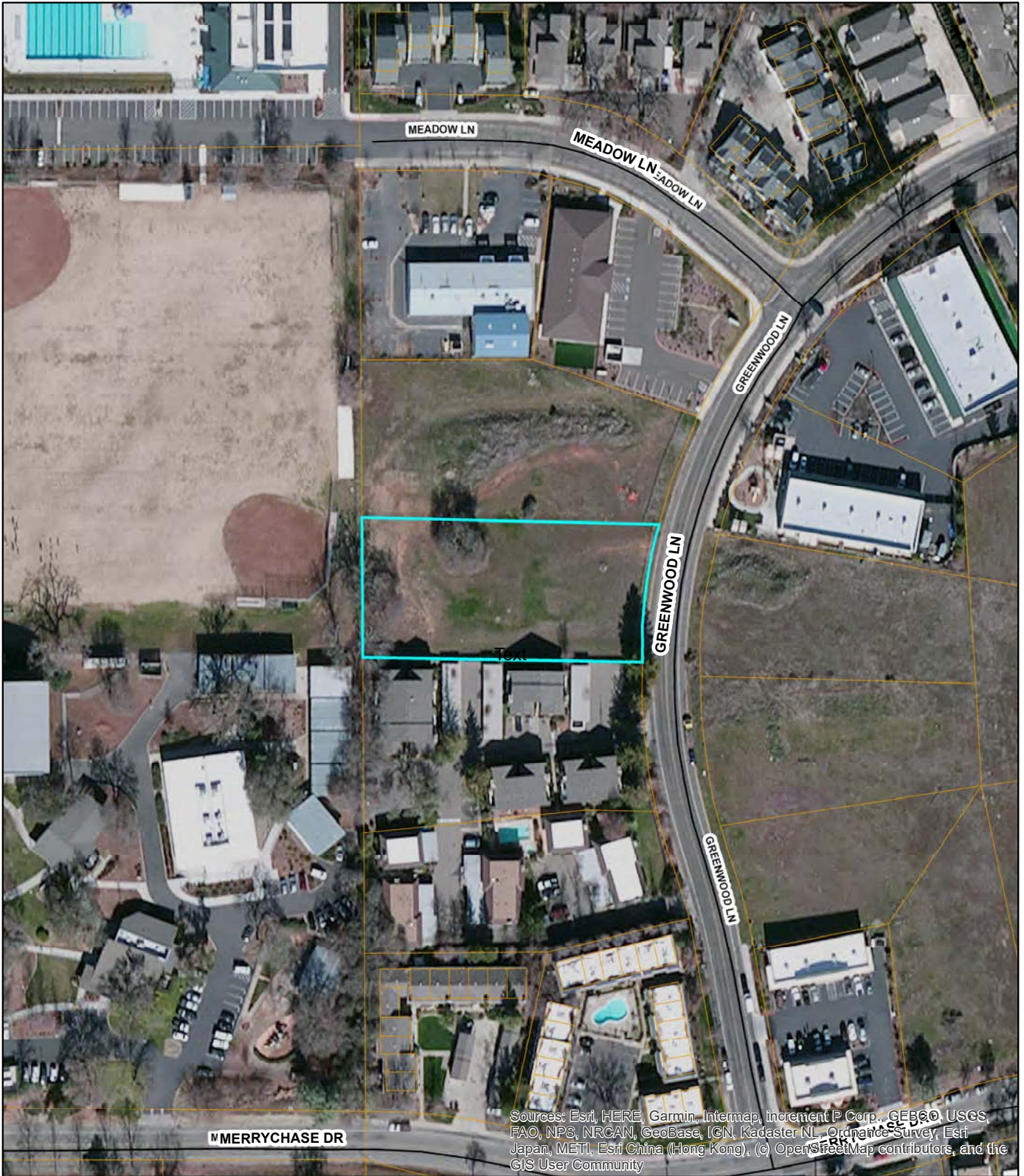

Sources: Esri, HERE, Garmin, Intermap, increment P Corp., GEBCO, USGS, FAO, NPS, NRCAN, GeoBase, IGN, Kadaster NL, Ordnance Survey, Esri Japan, METI, Esri China (Hong Kong), (c) OpenStreetMap contributors, and the GIS User Community

June 22, 2023

Site Aerial Photo

Search Results: Parcels — Highways

Disclaimer: Parcel boundaries in this map are illustrative only and not considered the legal boundary.

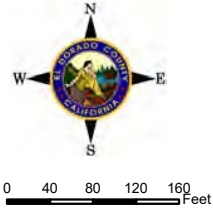

POR. SECS. 4 & 9, T.9N., R.9E., M.D.M.
CAMERON PARK NORTH UNIT NO. 5
D-93

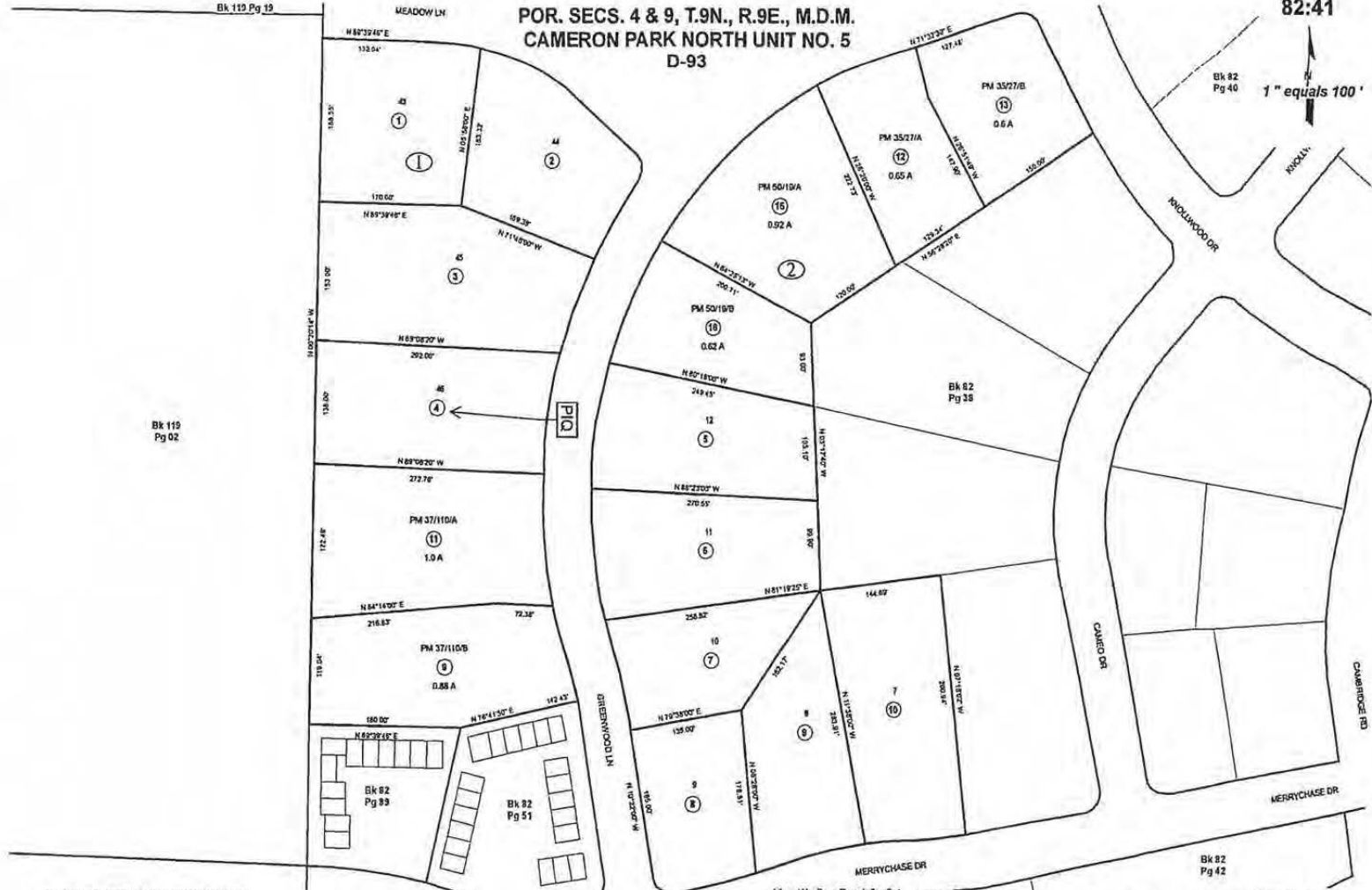

Acres are Estimates

THIS MAP IS NOT A SURVEY. It is prepared by the El Dorado Co. Assessor's Office for assessment purposes only. Area calculations and characteristics are not guaranteed. Users should verify items such as dimensions and acreage.

All Other Map Pages Shown in Grey Text
Assessor's Block Numbers Shown in Blue
Assessor's Parcel Numbers Shown in Circles

Rev. Mar. 14, 2008

Assessor's Map Bk. 82, Pr. County of El Dorado,

The map(s) is/are being furnished as an aid in locating the herein described land in relation to adjoining streets, natural boundaries and other land, and is not a survey of the land depicted. Except to the extent a policy of title insurance is expressly modified by endorsement, if any, the Company does not insure dimensions, distances, location of easements, acreage or other matters shown thereon.
 Non-Order Search Doc: CAE1D0MASS 82-00041
 Page 1 of 1
 Requested By: AMW1, Printed: 8/16/2021 9:54 PM

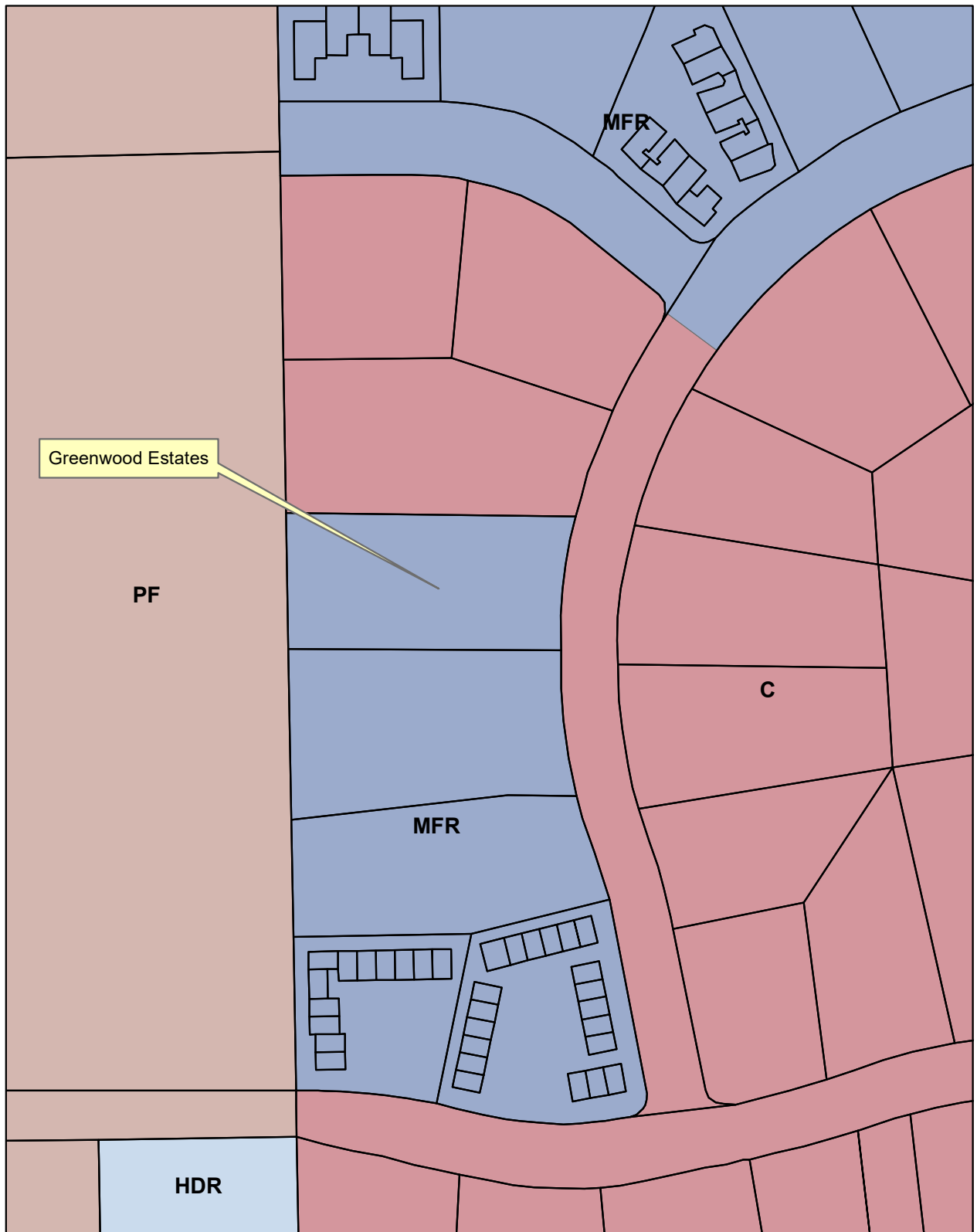

Greenwood Estates

PF

MFR

MFR

C







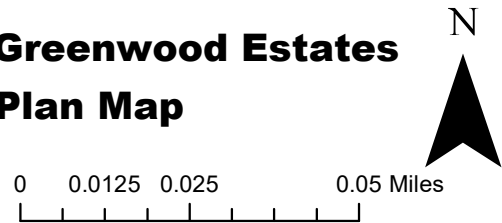

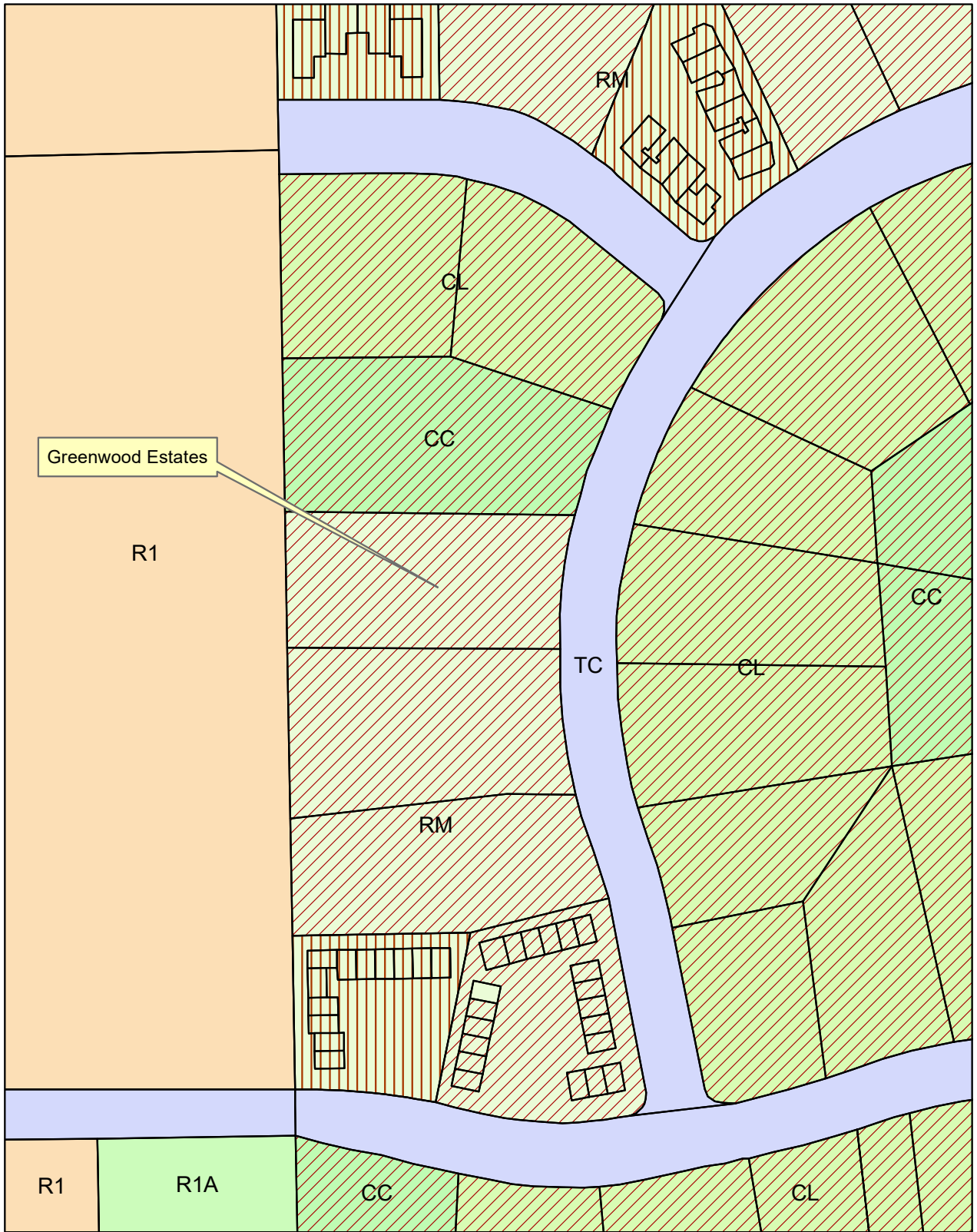
HDR

- C
- HDR
- MFR
- PF

**Z21-0012 PD21-0003 TM21-0001 Greenwood Estates
Attachment D - General Plan Map**





-  PD
-  DC
-  CC
-  CL
-  R1
-  R1A
-  RM
-  TC

**Z21-0012 PD21-0003 TM21-0001 Greenwood Estates
Attachment E - Zoning Map**

N



0 0.0125 0.025 0.05 Miles



Greenwood Estates Tentative Map / Rezone / Planned Development

2545 Greenwood Lane, Cameron Park, CA 95682
Lot 46, Cameron Park North, Unit No. 5
APN: 082-411-004 - El Dorado County, CA
October 2021

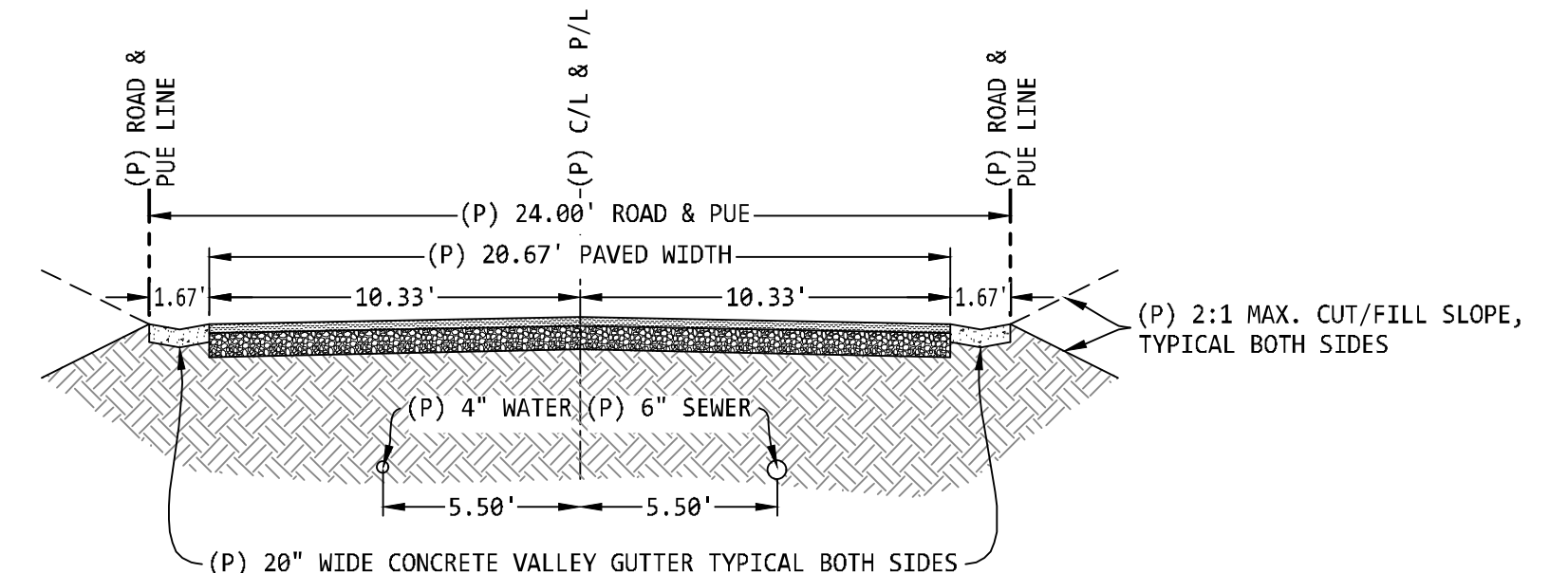
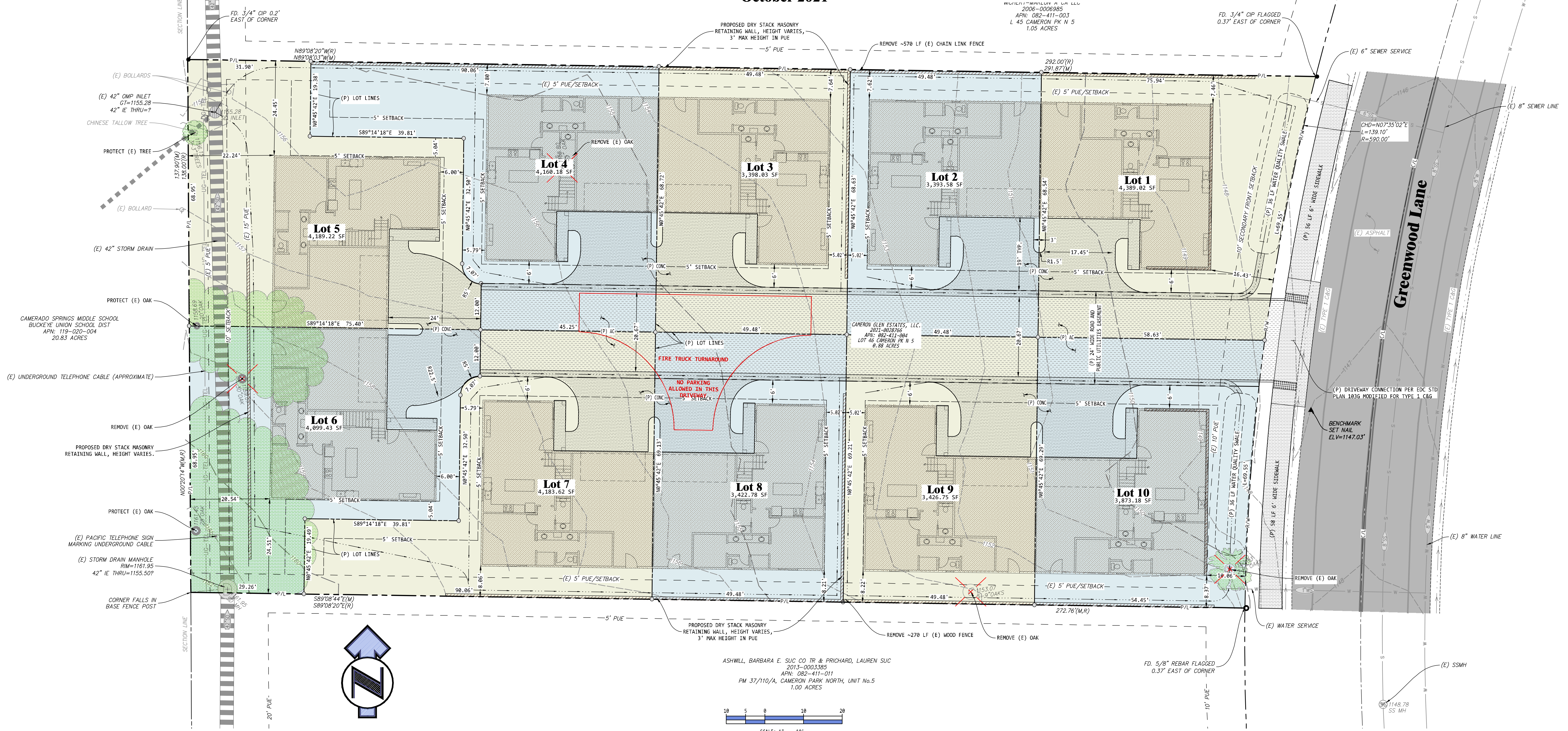

Typical Modified 101B Road & R/W Section
NOT TO SCALE

Proposed Duplex / Unit Area Summary

TYPICAL DUPLEX (2 UNITS) CONDITIONED SPACE = 3,724 SF
TYPICAL UNIT GROUND FLOOR CONDITIONED SPACE = 1,047 SF
TYPICAL UNIT GARAGE = 527 SF
TYPICAL UNIT PORCH = 39 SF
TYPICAL UNIT TOTAL UN-CONDITIONED SPACE = 566 SF
TYPICAL UNIT SECOND FLOOR CONDITIONED SPACE = 815 SF
TYPICAL UNIT TOTAL CONDITIONED SPACE = 1,862 SF

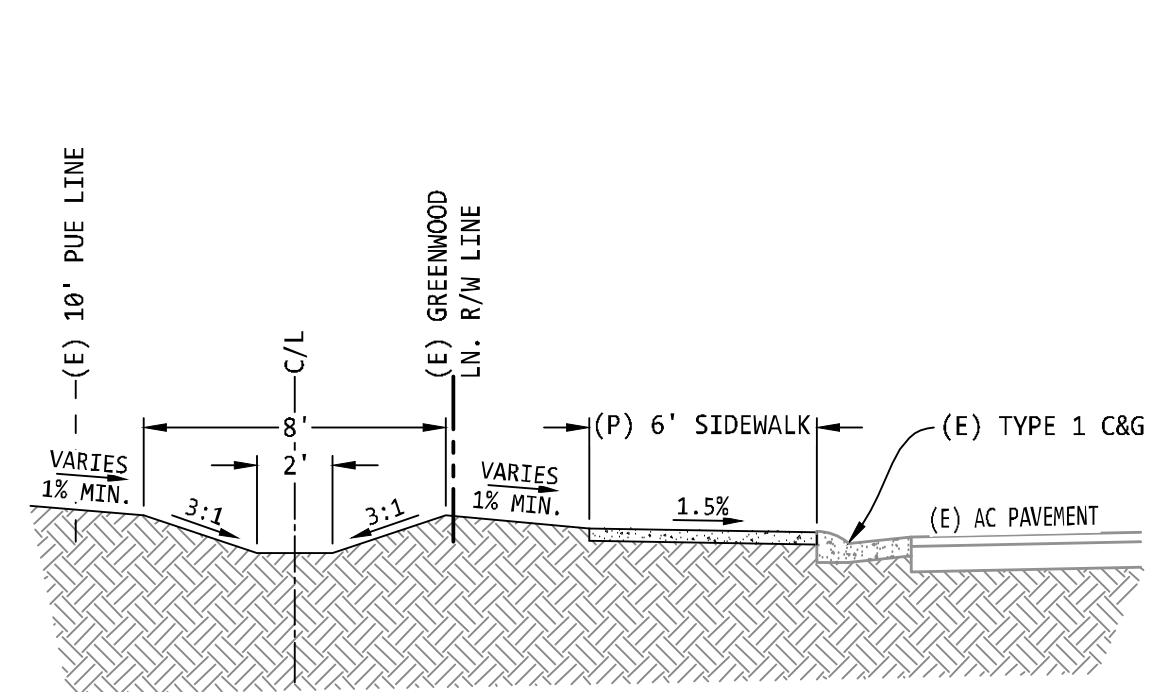

Typical Water Quality Swale Section
NOT TO SCALE

Abbreviations	
AC ASPHALTIC CONCRETE	GB GRADE BREAK
AB AGGREGATE BASE	LOC LIMITS OF CONSTRUCTION
BFP BACKFLOW PREVENTER	(M) MEASURED BEARING OR DISTANCE
BW BOTTOM OF WALL AT FG	(P) PROPOSED
CMP CORRUGATED METAL PIPE	PCC PORTLAND CEMENT CONCRETE
CN CONCRETE	POC POINT OF CONNECTION
CV CHECK VALVE	PUE PUBLIC UTILITIES EASEMENT
DCV DOUBLE CHECK VALVE	R RADIUS
DWY DRIVEWAY	(R) RECORD BEARING OR DISTANCE
(E) EXISTING	RPDA REDUCED PRESSURE DETECTOR ASSY
EL ELEVATION	SD STORM DRAIN
EP EDGE OF PAVEMENT	SS SANITARY SEWER
FDC FIRE DEPT. CONNECTION	TC TOP OF CURB ELEVATION
FF FINISHED FLOOR	TW TOP OF WALL
FG FINISHED GRADE	UP UTILITY POLE
FH FIRE HYDRANT	W WATER
FL FLOWLINE	WM WATER METER

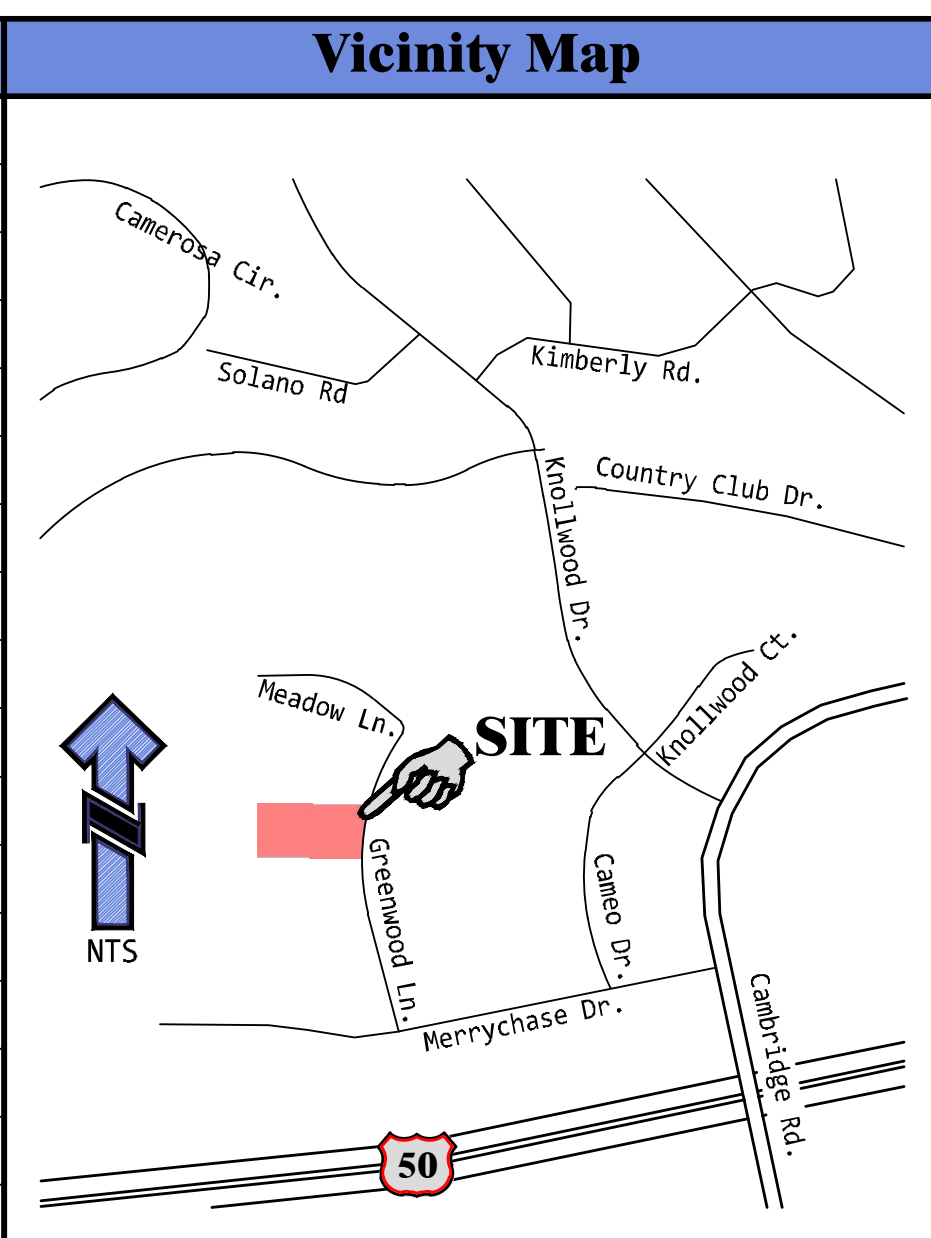

Project Data	
OWNER/APPLICANT:	Cameron Glen Estates, LLC c/o Joe Jaoudi 2216 Via Subria Visita, CA 95084 760-664-7196 josjaoudi@aol.com
PREPARED BY:	LEBECK ENGINEERING, INC. 2000 STATE ST., SUITE 200 DUBLIN, CA 94568 (916) 231-1000
SCALE:	1" = 10'
CONTOUR INTERVAL:	1 FOOT
SOURCE OF TOPOGRAPHY:	FIELD TOPOGRAPHY BY A.R. DIVERS PLS (1/27/2021)
SECTION, TOWNSHIP & RANGE:	POR. OF SW 1/4, SECTION 4, T.9N., R.9E., M.D.M.
ASSESSOR'S PARCEL NUMBER:	082-411-004
PRESENT LAND USE DESIGNATION:	MFR
PROPOSED LAND USE DESIGNATION:	MFR
PRESENT ZONING:	RM-DC
PROPOSED ZONING:	RM-PD
TOTAL AREA:	38,535.79 SF (0.88 ACRES)
TOTAL NUMBER OF PARCELS:	1 EXISTING, 10 PROPOSED
MINIMUM PARCEL AREA:	3,393.58 SF
WATER SUPPLY:	EID
SEWAGE DISPOSAL:	EID
FIRE PROTECTION:	CAMERON PARK CSD FIRE
DATE OF PREPARATION:	OCTOBER 2021
PROJECT #:	20-133

Lot Data	
Lot #	Gross Area
(E) LOT 46 CAMERON PARK NORTH UNIT #5	38,535.79 SF (0.88 Ac)
(P) Lot 1	4,389.02 SF
(P) Lot 2	3,393.58 SF
(P) Lot 3	3,398.03 SF
(P) Lot 4	4,166.18 SF
(P) Lot 5	4,189.22 SF
(P) Lot 6	4,099.43 SF
(P) Lot 7	4,183.62 SF
(P) Lot 8	3,422.78 SF
(P) Lot 9	3,426.75 SF
(P) Lot 10	3,873.18 SF

Approvals	
ZONING ADMINISTRATOR:	_____
APPROVAL/DENIAL DATE:	_____
BOARD OF SUPERVISORS:	_____
APPROVAL/DENIAL DATE:	_____

Greenwood Estates Detailed Report

Table of Contents

- 1. Basic Project Information
 - 1.1. Basic Project Information
 - 1.2. Land Use Types
 - 1.3. User-Selected Emission Reduction Measures by Emissions Sector
- 2. Emissions Summary
 - 2.1. Construction Emissions Compared Against Thresholds
 - 2.2. Construction Emissions by Year, Unmitigated
 - 2.4. Operations Emissions Compared Against Thresholds
 - 2.5. Operations Emissions by Sector, Unmitigated
- 3. Construction Emissions Details
 - 3.1. Demolition (2022) - Unmitigated
 - 3.3. Site Preparation (2022) - Unmitigated
 - 3.5. Grading (2022) - Unmitigated
 - 3.7. Building Construction (2022) - Unmitigated

3.9. Building Construction (2023) - Unmitigated

3.11. Paving (2023) - Unmitigated

3.13. Architectural Coating (2023) - Unmitigated

4. Operations Emissions Details

4.1. Mobile Emissions by Land Use

4.1.1. Unmitigated

4.2. Energy

4.2.1. Electricity Emissions By Land Use - Unmitigated

4.2.3. Natural Gas Emissions By Land Use - Unmitigated

4.3. Area Emissions by Source

4.3.2. Unmitigated

4.4. Water Emissions by Land Use

4.4.2. Unmitigated

4.5. Waste Emissions by Land Use

4.5.2. Unmitigated

4.6. Refrigerant Emissions by Land Use

4.6.1. Unmitigated

4.7. Offroad Emissions By Equipment Type

4.7.1. Unmitigated

4.8. Stationary Emissions By Equipment Type

4.8.1. Unmitigated

4.9. User Defined Emissions By Equipment Type

4.9.1. Unmitigated

4.10. Soil Carbon Accumulation By Vegetation Type

4.10.1. Soil Carbon Accumulation By Vegetation Type - Unmitigated

4.10.2. Above and Belowground Carbon Accumulation by Land Use Type - Unmitigated

4.10.3. Avoided and Sequestered Emissions by Species - Unmitigated

5. Activity Data

5.1. Construction Schedule

5.2. Off-Road Equipment

5.2.1. Unmitigated

5.3. Construction Vehicles

5.3.1. Unmitigated

5.4. Vehicles

- 5.4.1. Construction Vehicle Control Strategies
- 5.5. Architectural Coatings
- 5.6. Dust Mitigation
 - 5.6.1. Construction Earthmoving Activities
 - 5.6.2. Construction Earthmoving Control Strategies
- 5.7. Construction Paving
- 5.8. Construction Electricity Consumption and Emissions Factors
- 5.9. Operational Mobile Sources
 - 5.9.1. Unmitigated
- 5.10. Operational Area Sources
 - 5.10.1. Hearths
 - 5.10.1.1. Unmitigated
 - 5.10.2. Architectural Coatings
 - 5.10.3. Landscape Equipment
- 5.11. Operational Energy Consumption
 - 5.11.1. Unmitigated
- 5.12. Operational Water and Wastewater Consumption

5.12.1. Unmitigated

5.13. Operational Waste Generation

5.13.1. Unmitigated

5.14. Operational Refrigeration and Air Conditioning Equipment

5.14.1. Unmitigated

5.15. Operational Off-Road Equipment

5.15.1. Unmitigated

5.16. Stationary Sources

5.16.1. Emergency Generators and Fire Pumps

5.16.2. Process Boilers

5.17. User Defined

5.18. Vegetation

5.18.1. Land Use Change

5.18.1.1. Unmitigated

5.18.1. Biomass Cover Type

5.18.1.1. Unmitigated

5.18.2. Sequestration

5.18.2.1. Unmitigated

6. Climate Risk Detailed Report

6.1. Climate Risk Summary

6.2. Initial Climate Risk Scores

6.3. Adjusted Climate Risk Scores

6.4. Climate Risk Reduction Measures

7. Health and Equity Details

7.1. CalEnviroScreen 4.0 Scores

7.2. Healthy Places Index Scores

7.3. Overall Health & Equity Scores

7.4. Health & Equity Measures

7.5. Evaluation Scorecard

8. User Changes to Default Data

1. Basic Project Information

1.1. Basic Project Information

Data Field	Value
Project Name	Greenwood Estates
Lead Agency	El Dorado County
Land Use Scale	Project/site
Analysis Level for Defaults	County
Windspeed (m/s)	2.70
Precipitation (days)	10.4
Location	38.65878040568697, -121.00266914392049
County	El Dorado-Mountain County
City	Unincorporated
Air District	El Dorado County AQMD
Air Basin	Mountain Counties
TAZ	413
EDFZ	4
Electric Utility	Pacific Gas & Electric Company
Gas Utility	Pacific Gas & Electric

1.2. Land Use Types

Land Use Subtype	Size	Unit	Lot Acreage	Building Area (sq ft)	Landscape Area (sq ft)	Special Landscape Area (sq ft)	Population	Description
Condo/Townhouse	10.0	Dwelling Unit	0.88	18,620	10,000	0.00	25.0	duplexes

1.3. User-Selected Emission Reduction Measures by Emissions Sector

No measures selected

2. Emissions Summary

2.1. Construction Emissions Compared Against Thresholds

Criteria Pollutants (lb/day for daily, ton/yr for annual) and GHGs (lb/day for daily, MT/yr for annual)

Un/Mit.	TOG	ROG	NOx	CO	SO2	PM10E	PM10D	PM10T	PM2.5E	PM2.5D	PM2.5T	BCO2	NBCO2	CO2T	CH4	N2O	R	CO2e
Daily, Summer (Max)	—	—	—	—	—	—	—	—	—	—	—	—	—	—	—	—	—	—
Unmit.	1.64	1.38	13.9	11.7	0.02	0.67	5.31	5.98	0.62	2.57	3.18	—	1,712	1,712	0.07	0.02	0.48	1,718
Daily, Winter (Max)	—	—	—	—	—	—	—	—	—	—	—	—	—	—	—	—	—	—
Unmit.	0.81	117	6.77	7.66	0.01	0.34	4.74	5.08	0.31	0.48	0.80	—	1,416	1,416	0.06	0.02	0.01	1,423
Average Daily (Max)	—	—	—	—	—	—	—	—	—	—	—	—	—	—	—	—	—	—
Unmit.	0.19	1.65	1.59	1.78	< 0.005	0.08	0.98	1.06	0.07	0.11	0.18	—	318	318	0.01	< 0.005	0.04	320
Annual (Max)	—	—	—	—	—	—	—	—	—	—	—	—	—	—	—	—	—	—
Unmit.	0.03	0.30	0.29	0.32	< 0.005	0.01	0.18	0.19	0.01	0.02	0.03	—	52.7	52.7	< 0.005	< 0.005	0.01	52.9

2.2. Construction Emissions by Year, Unmitigated

Criteria Pollutants (lb/day for daily, ton/yr for annual) and GHGs (lb/day for daily, MT/yr for annual)

Year	TOG	ROG	NOx	CO	SO2	PM10E	PM10D	PM10T	PM2.5E	PM2.5D	PM2.5T	BCO2	NBCO2	CO2T	CH4	N2O	R	CO2e
Daily - Summer (Max)	—	—	—	—	—	—	—	—	—	—	—	—	—	—	—	—	—	—
2022	1.64	1.38	13.9	11.7	0.02	0.67	5.31	5.98	0.62	2.57	3.18	—	1,712	1,712	0.07	0.02	0.48	1,718

Daily - Winter (Max)	—	—	—	—	—	—	—	—	—	—	—	—	—	—	—	—	—	—
2022	0.81	0.68	6.77	7.66	0.01	0.34	4.74	5.08	0.31	0.48	0.80	—	1,416	1,416	0.06	0.02	0.01	1,423
2023	0.73	117	6.03	7.42	0.01	0.28	4.74	5.02	0.26	0.48	0.75	—	1,414	1,414	0.06	0.02	0.01	1,421
Average Daily	—	—	—	—	—	—	—	—	—	—	—	—	—	—	—	—	—	—
2022	0.19	0.16	1.59	1.78	< 0.005	0.08	0.98	1.06	0.07	0.11	0.18	—	318	318	0.01	< 0.005	0.04	320
2023	0.07	1.65	0.54	0.66	< 0.005	0.03	0.37	0.40	0.02	0.04	0.06	—	121	121	< 0.005	< 0.005	0.02	122
Annual	—	—	—	—	—	—	—	—	—	—	—	—	—	—	—	—	—	—
2022	0.03	0.03	0.29	0.32	< 0.005	0.01	0.18	0.19	0.01	0.02	0.03	—	52.7	52.7	< 0.005	< 0.005	0.01	52.9
2023	0.01	0.30	0.10	0.12	< 0.005	< 0.005	0.07	0.07	< 0.005	0.01	0.01	—	20.1	20.1	< 0.005	< 0.005	< 0.005	20.2

2.4. Operations Emissions Compared Against Thresholds

Criteria Pollutants (lb/day for daily, ton/yr for annual) and GHGs (lb/day for daily, MT/yr for annual)

Un/Mit.	TOG	ROG	NOx	CO	SO2	PM10E	PM10D	PM10T	PM2.5E	PM2.5D	PM2.5T	BCO2	NBCO2	CO2T	CH4	N2O	R	CO2e
Daily, Summer (Max)	—	—	—	—	—	—	—	—	—	—	—	—	—	—	—	—	—	—
Unmit.	17.3	17.5	1.28	25.8	0.05	2.62	5.42	8.04	2.61	0.83	3.44	280	1,426	1,706	0.54	0.08	5.72	1,749
Daily, Winter (Max)	—	—	—	—	—	—	—	—	—	—	—	—	—	—	—	—	—	—
Unmit.	17.2	17.4	1.41	24.5	0.05	2.62	5.42	8.04	2.61	0.83	3.44	280	1,340	1,620	0.55	0.08	0.28	1,659
Average Daily (Max)	—	—	—	—	—	—	—	—	—	—	—	—	—	—	—	—	—	—
Unmit.	4.93	5.36	1.03	9.53	0.02	0.60	4.85	5.46	0.60	0.74	1.34	64.6	1,148	1,213	0.34	0.06	2.29	1,242
Annual (Max)	—	—	—	—	—	—	—	—	—	—	—	—	—	—	—	—	—	—
Unmit.	0.90	0.98	0.19	1.74	< 0.005	0.11	0.89	1.00	0.11	0.14	0.25	10.7	190	201	0.06	0.01	0.38	206

2.5. Operations Emissions by Sector, Unmitigated

Criteria Pollutants (lb/day for daily, ton/yr for annual) and GHGs (lb/day for daily, MT/yr for annual)

Sector	TOG	ROG	NOx	CO	SO2	PM10E	PM10D	PM10T	PM2.5E	PM2.5D	PM2.5T	BCO2	NBCO2	CO2T	CH4	N2O	R	CO2e
Daily, Summer (Max)	—	—	—	—	—	—	—	—	—	—	—	—	—	—	—	—	—	—
Mobile	1.66	1.60	0.91	6.37	0.01	0.02	5.42	5.44	0.01	0.83	0.85	—	1,205	1,205	0.05	0.06	5.58	1,229
Area	15.6	15.9	0.30	19.5	0.03	2.60	—	2.60	2.59	—	2.59	278	117	395	0.26	0.02	—	407
Energy	0.01	< 0.005	0.06	0.02	< 0.005	< 0.005	—	< 0.005	< 0.005	—	< 0.005	—	103	103	0.01	< 0.005	—	104
Water	—	—	—	—	—	—	—	—	—	—	—	0.61	0.68	1.29	0.06	< 0.005	—	3.31
Waste	—	—	—	—	—	—	—	—	—	—	—	1.57	0.00	1.57	0.16	0.00	—	5.49
Refrig.	—	—	—	—	—	—	—	—	—	—	—	—	—	—	—	—	0.13	0.13
Total	17.3	17.5	1.28	25.8	0.05	2.62	5.42	8.04	2.61	0.83	3.44	280	1,426	1,706	0.54	0.08	5.72	1,749
Daily, Winter (Max)	—	—	—	—	—	—	—	—	—	—	—	—	—	—	—	—	—	—
Mobile	1.59	1.52	1.05	5.59	0.01	0.02	5.42	5.44	0.01	0.83	0.85	—	1,120	1,120	0.06	0.06	0.14	1,140
Area	15.6	15.9	0.30	18.9	0.03	2.60	—	2.60	2.59	—	2.59	278	116	394	0.26	0.02	—	406
Energy	0.01	< 0.005	0.06	0.02	< 0.005	< 0.005	—	< 0.005	< 0.005	—	< 0.005	—	103	103	0.01	< 0.005	—	104
Water	—	—	—	—	—	—	—	—	—	—	—	0.61	0.68	1.29	0.06	< 0.005	—	3.31
Waste	—	—	—	—	—	—	—	—	—	—	—	1.57	0.00	1.57	0.16	0.00	—	5.49
Refrig.	—	—	—	—	—	—	—	—	—	—	—	—	—	—	—	—	0.13	0.13
Total	17.2	17.4	1.41	24.5	0.05	2.62	5.42	8.04	2.61	0.83	3.44	280	1,340	1,620	0.55	0.08	0.28	1,659
Average Daily	—	—	—	—	—	—	—	—	—	—	—	—	—	—	—	—	—	—
Mobile	1.40	1.34	0.90	4.98	0.01	0.01	4.85	4.87	0.01	0.74	0.76	—	1,018	1,018	0.05	0.05	2.16	1,037
Area	3.52	4.02	0.07	4.52	0.01	0.58	—	0.58	0.58	—	0.58	62.4	26.8	89.2	0.06	< 0.005	—	91.9
Energy	0.01	< 0.005	0.06	0.02	< 0.005	< 0.005	—	< 0.005	< 0.005	—	< 0.005	—	103	103	0.01	< 0.005	—	104
Water	—	—	—	—	—	—	—	—	—	—	—	0.61	0.68	1.29	0.06	< 0.005	—	3.31

Waste	—	—	—	—	—	—	—	—	—	—	—	1.57	0.00	1.57	0.16	0.00	—	5.49
Refrig.	—	—	—	—	—	—	—	—	—	—	—	—	—	—	—	—	0.13	0.13
Total	4.93	5.36	1.03	9.53	0.02	0.60	4.85	5.46	0.60	0.74	1.34	64.6	1,148	1,213	0.34	0.06	2.29	1,242
Annual	—	—	—	—	—	—	—	—	—	—	—	—	—	—	—	—	—	—
Mobile	0.25	0.24	0.16	0.91	< 0.005	< 0.005	0.89	0.89	< 0.005	0.14	0.14	—	168	168	0.01	0.01	0.36	172
Area	0.64	0.73	0.01	0.83	< 0.005	0.11	—	0.11	0.11	—	0.11	10.3	4.43	14.8	0.01	< 0.005	—	15.2
Energy	< 0.005	< 0.005	0.01	< 0.005	< 0.005	< 0.005	—	< 0.005	< 0.005	—	< 0.005	—	17.1	17.1	< 0.005	< 0.005	—	17.2
Water	—	—	—	—	—	—	—	—	—	—	—	0.10	0.11	0.21	0.01	< 0.005	—	0.55
Waste	—	—	—	—	—	—	—	—	—	—	—	0.26	0.00	0.26	0.03	0.00	—	0.91
Refrig.	—	—	—	—	—	—	—	—	—	—	—	—	—	—	—	—	0.02	0.02
Total	0.90	0.98	0.19	1.74	< 0.005	0.11	0.89	1.00	0.11	0.14	0.25	10.7	190	201	0.06	0.01	0.38	206

3. Construction Emissions Details

3.1. Demolition (2022) - Unmitigated

Criteria Pollutants (lb/day for daily, ton/yr for annual) and GHGs (lb/day for daily, MT/yr for annual)

Location	TOG	ROG	NOx	CO	SO2	PM10E	PM10D	PM10T	PM2.5E	PM2.5D	PM2.5T	BCO2	NBCO2	CO2T	CH4	N2O	R	CO2e
Onsite	—	—	—	—	—	—	—	—	—	—	—	—	—	—	—	—	—	—
Daily, Summer (Max)	—	—	—	—	—	—	—	—	—	—	—	—	—	—	—	—	—	—
Off-Road Equipment	0.71	0.59	5.36	5.99	0.01	0.25	—	0.25	0.23	—	0.23	—	852	852	0.03	0.01	—	855
Demolition	—	—	—	—	—	—	0.00	0.00	—	0.00	0.00	—	—	—	—	—	—	—
Onsite truck	0.00	0.00	0.00	0.00	0.00	0.00	0.00	0.00	0.00	0.00	0.00	—	0.00	0.00	0.00	0.00	0.00	0.00
Daily, Winter (Max)	—	—	—	—	—	—	—	—	—	—	—	—	—	—	—	—	—	—

Average Daily	—	—	—	—	—	—	—	—	—	—	—	—	—	—	—	—	—	—	—
Off-Road Equipment	0.02	0.02	0.15	0.16	< 0.005	0.01	—	0.01	0.01	—	0.01	—	23.3	23.3	< 0.005	< 0.005	—	23.4	
Demolition	—	—	—	—	—	—	0.00	0.00	—	0.00	0.00	—	—	—	—	—	—	—	
Onsite truck	0.00	0.00	0.00	0.00	0.00	0.00	0.00	0.00	0.00	0.00	0.00	—	0.00	0.00	0.00	0.00	0.00	0.00	
Annual	—	—	—	—	—	—	—	—	—	—	—	—	—	—	—	—	—	—	
Off-Road Equipment	< 0.005	< 0.005	0.03	0.03	< 0.005	< 0.005	—	< 0.005	< 0.005	—	< 0.005	—	3.86	3.86	< 0.005	< 0.005	—	3.88	
Demolition	—	—	—	—	—	—	0.00	0.00	—	0.00	0.00	—	—	—	—	—	—	—	
Onsite truck	0.00	0.00	0.00	0.00	0.00	0.00	0.00	0.00	0.00	0.00	0.00	—	0.00	0.00	0.00	0.00	0.00	0.00	
Offsite	—	—	—	—	—	—	—	—	—	—	—	—	—	—	—	—	—	—	
Daily, Summer (Max)	—	—	—	—	—	—	—	—	—	—	—	—	—	—	—	—	—	—	
Worker	0.00	0.00	0.00	0.00	0.00	0.00	0.00	0.00	0.00	0.00	0.00	—	0.00	0.00	0.00	0.00	0.00	0.00	
Vendor	0.00	0.00	0.00	0.00	0.00	0.00	0.00	0.00	0.00	0.00	0.00	—	0.00	0.00	0.00	0.00	0.00	0.00	
Hauling	0.00	0.00	0.00	0.00	0.00	0.00	0.00	0.00	0.00	0.00	0.00	—	0.00	0.00	0.00	0.00	0.00	0.00	
Daily, Winter (Max)	—	—	—	—	—	—	—	—	—	—	—	—	—	—	—	—	—	—	
Average Daily	—	—	—	—	—	—	—	—	—	—	—	—	—	—	—	—	—	—	
Worker	0.00	0.00	0.00	0.00	0.00	0.00	0.00	0.00	0.00	0.00	0.00	—	0.00	0.00	0.00	0.00	0.00	0.00	
Vendor	0.00	0.00	0.00	0.00	0.00	0.00	0.00	0.00	0.00	0.00	0.00	—	0.00	0.00	0.00	0.00	0.00	0.00	
Hauling	0.00	0.00	0.00	0.00	0.00	0.00	0.00	0.00	0.00	0.00	0.00	—	0.00	0.00	0.00	0.00	0.00	0.00	
Annual	—	—	—	—	—	—	—	—	—	—	—	—	—	—	—	—	—	—	
Worker	0.00	0.00	0.00	0.00	0.00	0.00	0.00	0.00	0.00	0.00	0.00	—	0.00	0.00	0.00	0.00	0.00	0.00	

Vendor	0.00	0.00	0.00	0.00	0.00	0.00	0.00	0.00	0.00	0.00	0.00	0.00	—	0.00	0.00	0.00	0.00	0.00	0.00
Hauling	0.00	0.00	0.00	0.00	0.00	0.00	0.00	0.00	0.00	0.00	0.00	0.00	—	0.00	0.00	0.00	0.00	0.00	0.00

3.3. Site Preparation (2022) - Unmitigated

Criteria Pollutants (lb/day for daily, ton/yr for annual) and GHGs (lb/day for daily, MT/yr for annual)

Location	TOG	ROG	NOx	CO	SO2	PM10E	PM10D	PM10T	PM2.5E	PM2.5D	PM2.5T	BCO2	NBCO2	CO2T	CH4	N2O	R	CO2e
Onsite	—	—	—	—	—	—	—	—	—	—	—	—	—	—	—	—	—	—
Daily, Summer (Max)	—	—	—	—	—	—	—	—	—	—	—	—	—	—	—	—	—	—
Off-Road Equipment	0.71	0.60	5.74	5.62	0.01	0.31	—	0.31	0.29	—	0.29	—	857	857	0.03	0.01	—	860
Dust From Material Movement:	—	—	—	—	—	—	0.53	0.53	—	0.06	0.06	—	—	—	—	—	—	—
Onsite truck	0.00	0.00	0.00	0.00	0.00	0.00	0.00	0.00	0.00	0.00	0.00	—	0.00	0.00	0.00	0.00	0.00	0.00
Daily, Winter (Max)	—	—	—	—	—	—	—	—	—	—	—	—	—	—	—	—	—	—
Average Daily	—	—	—	—	—	—	—	—	—	—	—	—	—	—	—	—	—	—
Off-Road Equipment	< 0.005	< 0.005	0.02	0.02	< 0.005	< 0.005	—	< 0.005	< 0.005	—	< 0.005	—	2.35	2.35	< 0.005	< 0.005	—	2.36
Dust From Material Movement:	—	—	—	—	—	—	< 0.005	< 0.005	—	< 0.005	< 0.005	—	—	—	—	—	—	—
Onsite truck	0.00	0.00	0.00	0.00	0.00	0.00	0.00	0.00	0.00	0.00	0.00	—	0.00	0.00	0.00	0.00	0.00	0.00
Annual	—	—	—	—	—	—	—	—	—	—	—	—	—	—	—	—	—	—

Off-Road Equipment	< 0.005	< 0.005	< 0.005	< 0.005	< 0.005	< 0.005	—	< 0.005	< 0.005	—	< 0.005	—	0.39	0.39	< 0.005	< 0.005	—	0.39
Dust From Material Movement:	—	—	—	—	—	—	< 0.005	< 0.005	—	< 0.005	< 0.005	—	—	—	—	—	—	—
Onsite truck	0.00	0.00	0.00	0.00	0.00	0.00	0.00	0.00	0.00	0.00	0.00	—	0.00	0.00	0.00	0.00	0.00	0.00
Offsite	—	—	—	—	—	—	—	—	—	—	—	—	—	—	—	—	—	—
Daily, Summer (Max)	—	—	—	—	—	—	—	—	—	—	—	—	—	—	—	—	—	—
Worker	0.00	0.00	0.00	0.00	0.00	0.00	0.00	0.00	0.00	0.00	0.00	—	0.00	0.00	0.00	0.00	0.00	0.00
Vendor	0.00	0.00	0.00	0.00	0.00	0.00	0.00	0.00	0.00	0.00	0.00	—	0.00	0.00	0.00	0.00	0.00	0.00
Hauling	0.00	0.00	0.00	0.00	0.00	0.00	0.00	0.00	0.00	0.00	0.00	—	0.00	0.00	0.00	0.00	0.00	0.00
Daily, Winter (Max)	—	—	—	—	—	—	—	—	—	—	—	—	—	—	—	—	—	—
Average Daily	—	—	—	—	—	—	—	—	—	—	—	—	—	—	—	—	—	—
Worker	0.00	0.00	0.00	0.00	0.00	0.00	0.00	0.00	0.00	0.00	0.00	—	0.00	0.00	0.00	0.00	0.00	0.00
Vendor	0.00	0.00	0.00	0.00	0.00	0.00	0.00	0.00	0.00	0.00	0.00	—	0.00	0.00	0.00	0.00	0.00	0.00
Hauling	0.00	0.00	0.00	0.00	0.00	0.00	0.00	0.00	0.00	0.00	0.00	—	0.00	0.00	0.00	0.00	0.00	0.00
Annual	—	—	—	—	—	—	—	—	—	—	—	—	—	—	—	—	—	—
Worker	0.00	0.00	0.00	0.00	0.00	0.00	0.00	0.00	0.00	0.00	0.00	—	0.00	0.00	0.00	0.00	0.00	0.00
Vendor	0.00	0.00	0.00	0.00	0.00	0.00	0.00	0.00	0.00	0.00	0.00	—	0.00	0.00	0.00	0.00	0.00	0.00
Hauling	0.00	0.00	0.00	0.00	0.00	0.00	0.00	0.00	0.00	0.00	0.00	—	0.00	0.00	0.00	0.00	0.00	0.00

3.5. Grading (2022) - Unmitigated

Criteria Pollutants (lb/day for daily, ton/yr for annual) and GHGs (lb/day for daily, MT/yr for annual)

Location	TOG	ROG	NOx	CO	SO2	PM10E	PM10D	PM10T	PM2.5E	PM2.5D	PM2.5T	BCO2	NBCO2	CO2T	CH4	N2O	R	CO2e
----------	-----	-----	-----	----	-----	-------	-------	-------	--------	--------	--------	------	-------	------	-----	-----	---	------

Onsite	—	—	—	—	—	—	—	—	—	—	—	—	—	—	—	—	—	—
Daily, Summer (Max)	—	—	—	—	—	—	—	—	—	—	—	—	—	—	—	—	—	—
Off-Road Equipment	1.64	1.38	13.9	11.7	0.02	0.67	—	0.67	0.62	—	0.62	—	1,712	1,712	0.07	0.01	—	1,718
Dust From Material Movement:	—	—	—	—	—	—	5.31	5.31	—	2.57	2.57	—	—	—	—	—	—	—
Onsite truck	0.00	0.00	0.00	0.00	0.00	0.00	0.00	0.00	0.00	0.00	0.00	—	0.00	0.00	0.00	0.00	0.00	0.00
Daily, Winter (Max)	—	—	—	—	—	—	—	—	—	—	—	—	—	—	—	—	—	—
Average Daily	—	—	—	—	—	—	—	—	—	—	—	—	—	—	—	—	—	—
Off-Road Equipment	0.01	0.01	0.08	0.06	< 0.005	< 0.005	—	< 0.005	< 0.005	—	< 0.005	—	9.38	9.38	< 0.005	< 0.005	—	9.41
Dust From Material Movement:	—	—	—	—	—	—	0.03	0.03	—	0.01	0.01	—	—	—	—	—	—	—
Onsite truck	0.00	0.00	0.00	0.00	0.00	0.00	0.00	0.00	0.00	0.00	0.00	—	0.00	0.00	0.00	0.00	0.00	0.00
Annual	—	—	—	—	—	—	—	—	—	—	—	—	—	—	—	—	—	—
Off-Road Equipment	< 0.005	< 0.005	0.01	0.01	< 0.005	< 0.005	—	< 0.005	< 0.005	—	< 0.005	—	1.55	1.55	< 0.005	< 0.005	—	1.56
Dust From Material Movement:	—	—	—	—	—	—	0.01	0.01	—	< 0.005	< 0.005	—	—	—	—	—	—	—
Onsite truck	0.00	0.00	0.00	0.00	0.00	0.00	0.00	0.00	0.00	0.00	0.00	—	0.00	0.00	0.00	0.00	0.00	0.00
Offsite	—	—	—	—	—	—	—	—	—	—	—	—	—	—	—	—	—	—

Daily, Summer (Max)	—	—	—	—	—	—	—	—	—	—	—	—	—	—	—	—	—	—
Worker	0.00	0.00	0.00	0.00	0.00	0.00	0.00	0.00	0.00	0.00	0.00	—	0.00	0.00	0.00	0.00	0.00	0.00
Vendor	0.00	0.00	0.00	0.00	0.00	0.00	0.00	0.00	0.00	0.00	0.00	—	0.00	0.00	0.00	0.00	0.00	0.00
Hauling	0.00	0.00	0.00	0.00	0.00	0.00	0.00	0.00	0.00	0.00	0.00	—	0.00	0.00	0.00	0.00	0.00	0.00
Daily, Winter (Max)	—	—	—	—	—	—	—	—	—	—	—	—	—	—	—	—	—	—
Average Daily	—	—	—	—	—	—	—	—	—	—	—	—	—	—	—	—	—	—
Worker	0.00	0.00	0.00	0.00	0.00	0.00	0.00	0.00	0.00	0.00	0.00	—	0.00	0.00	0.00	0.00	0.00	0.00
Vendor	0.00	0.00	0.00	0.00	0.00	0.00	0.00	0.00	0.00	0.00	0.00	—	0.00	0.00	0.00	0.00	0.00	0.00
Hauling	0.00	0.00	0.00	0.00	0.00	0.00	0.00	0.00	0.00	0.00	0.00	—	0.00	0.00	0.00	0.00	0.00	0.00
Annual	—	—	—	—	—	—	—	—	—	—	—	—	—	—	—	—	—	—
Worker	0.00	0.00	0.00	0.00	0.00	0.00	0.00	0.00	0.00	0.00	0.00	—	0.00	0.00	0.00	0.00	0.00	0.00
Vendor	0.00	0.00	0.00	0.00	0.00	0.00	0.00	0.00	0.00	0.00	0.00	—	0.00	0.00	0.00	0.00	0.00	0.00
Hauling	0.00	0.00	0.00	0.00	0.00	0.00	0.00	0.00	0.00	0.00	0.00	—	0.00	0.00	0.00	0.00	0.00	0.00

3.7. Building Construction (2022) - Unmitigated

Criteria Pollutants (lb/day for daily, ton/yr for annual) and GHGs (lb/day for daily, MT/yr for annual)

Location	TOG	ROG	NOx	CO	SO2	PM10E	PM10D	PM10T	PM2.5E	PM2.5D	PM2.5T	BCO2	NBCO2	CO2T	CH4	N2O	R	CO2e
Onsite	—	—	—	—	—	—	—	—	—	—	—	—	—	—	—	—	—	—
Daily, Summer (Max)	—	—	—	—	—	—	—	—	—	—	—	—	—	—	—	—	—	—
Off-Road Equipment	0.77	0.64	6.66	7.21	0.01	0.34	—	0.34	0.31	—	0.31	—	1,305	1,305	0.05	0.01	—	1,309
Onsite truck	0.00	0.00	0.00	0.00	0.00	0.00	0.00	0.00	0.00	0.00	0.00	—	0.00	0.00	0.00	0.00	0.00	0.00

Daily, Winter (Max)	—	—	—	—	—	—	—	—	—	—	—	—	—	—	—	—	—	—
Off-Road Equipment	0.77	0.64	6.66	7.21	0.01	0.34	—	0.34	0.31	—	0.31	—	1,305	1,305	0.05	0.01	—	1,309
Onsite truck	0.00	0.00	0.00	0.00	0.00	0.00	0.00	0.00	0.00	0.00	0.00	—	0.00	0.00	0.00	0.00	0.00	0.00
Average Daily	—	—	—	—	—	—	—	—	—	—	—	—	—	—	—	—	—	—
Off-Road Equipment	0.15	0.13	1.33	1.44	< 0.005	0.07	—	0.07	0.06	—	0.06	—	260	260	0.01	< 0.005	—	261
Onsite truck	0.00	0.00	0.00	0.00	0.00	0.00	0.00	0.00	0.00	0.00	0.00	—	0.00	0.00	0.00	0.00	0.00	0.00
Annual	—	—	—	—	—	—	—	—	—	—	—	—	—	—	—	—	—	—
Off-Road Equipment	0.03	0.02	0.24	0.26	< 0.005	0.01	—	0.01	0.01	—	0.01	—	43.1	43.1	< 0.005	< 0.005	—	43.3
Onsite truck	0.00	0.00	0.00	0.00	0.00	0.00	0.00	0.00	0.00	0.00	0.00	—	0.00	0.00	0.00	0.00	0.00	0.00
Offsite	—	—	—	—	—	—	—	—	—	—	—	—	—	—	—	—	—	—
Daily, Summer (Max)	—	—	—	—	—	—	—	—	—	—	—	—	—	—	—	—	—	—
Worker	0.05	0.04	0.03	0.57	0.00	0.00	< 0.005	< 0.005	0.00	0.00	0.00	—	85.3	85.3	< 0.005	< 0.005	0.40	86.6
Vendor	< 0.005	< 0.005	0.07	0.01	< 0.005	< 0.005	< 0.005	< 0.005	< 0.005	< 0.005	< 0.005	—	34.8	34.8	< 0.005	0.01	0.08	36.4
Hauling	0.00	0.00	0.00	0.00	0.00	0.00	0.00	0.00	0.00	0.00	0.00	—	0.00	0.00	0.00	0.00	0.00	0.00
Daily, Winter (Max)	—	—	—	—	—	—	—	—	—	—	—	—	—	—	—	—	—	—
Worker	0.04	0.04	0.04	0.44	0.00	0.00	< 0.005	< 0.005	0.00	0.00	0.00	—	76.6	76.6	< 0.005	< 0.005	0.01	77.7
Vendor	< 0.005	< 0.005	0.07	0.01	< 0.005	< 0.005	< 0.005	< 0.005	< 0.005	< 0.005	< 0.005	—	34.7	34.7	< 0.005	0.01	< 0.005	36.3
Hauling	0.00	0.00	0.00	0.00	0.00	0.00	0.00	0.00	0.00	0.00	0.00	—	0.00	0.00	0.00	0.00	0.00	0.00
Average Daily	—	—	—	—	—	—	—	—	—	—	—	—	—	—	—	—	—	—

Worker	0.01	0.01	0.01	0.09	0.00	0.00	< 0.005	< 0.005	0.00	0.00	0.00	—	15.6	15.6	< 0.005	< 0.005	0.03	15.9
Vendor	< 0.005	< 0.005	0.01	< 0.005	< 0.005	< 0.005	< 0.005	< 0.005	< 0.005	< 0.005	< 0.005	—	6.93	6.93	< 0.005	< 0.005	0.01	7.26
Hauling	0.00	0.00	0.00	0.00	0.00	0.00	0.00	0.00	0.00	0.00	0.00	—	0.00	0.00	0.00	0.00	0.00	0.00
Annual	—	—	—	—	—	—	—	—	—	—	—	—	—	—	—	—	—	—
Worker	< 0.005	< 0.005	< 0.005	0.02	0.00	0.00	< 0.005	< 0.005	0.00	0.00	0.00	—	2.59	2.59	< 0.005	< 0.005	0.01	2.63
Vendor	< 0.005	< 0.005	< 0.005	< 0.005	< 0.005	< 0.005	< 0.005	< 0.005	< 0.005	< 0.005	< 0.005	—	1.15	1.15	< 0.005	< 0.005	< 0.005	1.20
Hauling	0.00	0.00	0.00	0.00	0.00	0.00	0.00	0.00	0.00	0.00	0.00	—	0.00	0.00	0.00	0.00	0.00	0.00

3.9. Building Construction (2023) - Unmitigated

Criteria Pollutants (lb/day for daily, ton/yr for annual) and GHGs (lb/day for daily, MT/yr for annual)

Location	TOG	ROG	NOx	CO	SO2	PM10E	PM10D	PM10T	PM2.5E	PM2.5D	PM2.5T	BCO2	NBCO2	CO2T	CH4	N2O	R	CO2e
Onsite	—	—	—	—	—	—	—	—	—	—	—	—	—	—	—	—	—	—
Daily, Summer (Max)	—	—	—	—	—	—	—	—	—	—	—	—	—	—	—	—	—	—
Daily, Winter (Max)	—	—	—	—	—	—	—	—	—	—	—	—	—	—	—	—	—	—
Off-Road Equipment	0.69	0.58	5.93	7.00	0.01	0.28	—	0.28	0.26	—	0.26	—	1,305	1,305	0.05	0.01	—	1,309
Onsite truck	0.00	0.00	0.00	0.00	0.00	0.00	0.00	0.00	0.00	0.00	0.00	—	0.00	0.00	0.00	0.00	0.00	0.00
Average Daily	—	—	—	—	—	—	—	—	—	—	—	—	—	—	—	—	—	—
Off-Road Equipment	0.05	0.04	0.45	0.53	< 0.005	0.02	—	0.02	0.02	—	0.02	—	99.6	99.6	< 0.005	< 0.005	—	99.9
Onsite truck	0.00	0.00	0.00	0.00	0.00	0.00	0.00	0.00	0.00	0.00	0.00	—	0.00	0.00	0.00	0.00	0.00	0.00
Annual	—	—	—	—	—	—	—	—	—	—	—	—	—	—	—	—	—	—
Off-Road Equipment	0.01	0.01	0.08	0.10	< 0.005	< 0.005	—	< 0.005	< 0.005	—	< 0.005	—	16.5	16.5	< 0.005	< 0.005	—	16.5

Onsite truck	0.00	0.00	0.00	0.00	0.00	0.00	0.00	0.00	0.00	0.00	0.00	—	0.00	0.00	0.00	0.00	0.00	0.00
Offsite	—	—	—	—	—	—	—	—	—	—	—	—	—	—	—	—	—	—
Daily, Summer (Max)	—	—	—	—	—	—	—	—	—	—	—	—	—	—	—	—	—	—
Daily, Winter (Max)	—	—	—	—	—	—	—	—	—	—	—	—	—	—	—	—	—	—
Worker	0.04	0.04	0.04	0.41	0.00	0.00	< 0.005	< 0.005	0.00	0.00	0.00	—	75.3	75.3	< 0.005	< 0.005	0.01	76.3
Vendor	< 0.005	< 0.005	0.06	0.01	< 0.005	< 0.005	< 0.005	< 0.005	< 0.005	< 0.005	< 0.005	—	34.4	34.4	< 0.005	0.01	< 0.005	36.0
Hauling	0.00	0.00	0.00	0.00	0.00	0.00	0.00	0.00	0.00	0.00	0.00	—	0.00	0.00	0.00	0.00	0.00	0.00
Average Daily	—	—	—	—	—	—	—	—	—	—	—	—	—	—	—	—	—	—
Worker	< 0.005	< 0.005	< 0.005	0.03	0.00	0.00	< 0.005	< 0.005	0.00	0.00	0.00	—	5.87	5.87	< 0.005	< 0.005	0.01	5.96
Vendor	< 0.005	< 0.005	< 0.005	< 0.005	< 0.005	< 0.005	< 0.005	< 0.005	< 0.005	< 0.005	< 0.005	—	2.63	2.63	< 0.005	< 0.005	< 0.005	2.75
Hauling	0.00	0.00	0.00	0.00	0.00	0.00	0.00	0.00	0.00	0.00	0.00	—	0.00	0.00	0.00	0.00	0.00	0.00
Annual	—	—	—	—	—	—	—	—	—	—	—	—	—	—	—	—	—	—
Worker	< 0.005	< 0.005	< 0.005	0.01	0.00	0.00	< 0.005	< 0.005	0.00	0.00	0.00	—	0.97	0.97	< 0.005	< 0.005	< 0.005	0.99
Vendor	< 0.005	< 0.005	< 0.005	< 0.005	< 0.005	< 0.005	< 0.005	< 0.005	< 0.005	< 0.005	< 0.005	—	0.44	0.44	< 0.005	< 0.005	< 0.005	0.46
Hauling	0.00	0.00	0.00	0.00	0.00	0.00	0.00	0.00	0.00	0.00	0.00	—	0.00	0.00	0.00	0.00	0.00	0.00

3.11. Paving (2023) - Unmitigated

Criteria Pollutants (lb/day for daily, ton/yr for annual) and GHGs (lb/day for daily, MT/yr for annual)

Location	TOG	ROG	NOx	CO	SO2	PM10E	PM10D	PM10T	PM2.5E	PM2.5D	PM2.5T	BCO2	NBCO2	CO2T	CH4	N2O	R	CO2e
Onsite	—	—	—	—	—	—	—	—	—	—	—	—	—	—	—	—	—	—
Daily, Summer (Max)	—	—	—	—	—	—	—	—	—	—	—	—	—	—	—	—	—	—

Daily, Winter (Max)	—	—	—	—	—	—	—	—	—	—	—	—	—	—	—	—	—	—
Off-Road Equipment	0.64	0.53	4.61	5.32	0.01	0.22	—	0.22	0.20	—	0.20	—	823	823	0.03	0.01	—	826
Paving	—	0.00	—	—	—	—	—	—	—	—	—	—	—	—	—	—	—	—
Onsite truck	0.00	0.00	0.00	0.00	0.00	0.00	0.00	0.00	0.00	0.00	0.00	—	0.00	0.00	0.00	0.00	0.00	0.00
Average Daily	—	—	—	—	—	—	—	—	—	—	—	—	—	—	—	—	—	—
Off-Road Equipment	0.01	0.01	0.06	0.07	< 0.005	< 0.005	—	< 0.005	< 0.005	—	< 0.005	—	11.3	11.3	< 0.005	< 0.005	—	11.3
Paving	—	0.00	—	—	—	—	—	—	—	—	—	—	—	—	—	—	—	—
Onsite truck	0.00	0.00	0.00	0.00	0.00	0.00	0.00	0.00	0.00	0.00	0.00	—	0.00	0.00	0.00	0.00	0.00	0.00
Annual	—	—	—	—	—	—	—	—	—	—	—	—	—	—	—	—	—	—
Off-Road Equipment	< 0.005	< 0.005	0.01	0.01	< 0.005	< 0.005	—	< 0.005	< 0.005	—	< 0.005	—	1.87	1.87	< 0.005	< 0.005	—	1.87
Paving	—	0.00	—	—	—	—	—	—	—	—	—	—	—	—	—	—	—	—
Onsite truck	0.00	0.00	0.00	0.00	0.00	0.00	0.00	0.00	0.00	0.00	0.00	—	0.00	0.00	0.00	0.00	0.00	0.00
Offsite	—	—	—	—	—	—	—	—	—	—	—	—	—	—	—	—	—	—
Daily, Summer (Max)	—	—	—	—	—	—	—	—	—	—	—	—	—	—	—	—	—	—
Daily, Winter (Max)	—	—	—	—	—	—	—	—	—	—	—	—	—	—	—	—	—	—
Worker	0.00	0.00	0.00	0.00	0.00	0.00	0.00	0.00	0.00	0.00	0.00	—	0.00	0.00	0.00	0.00	0.00	0.00
Vendor	0.00	0.00	0.00	0.00	0.00	0.00	0.00	0.00	0.00	0.00	0.00	—	0.00	0.00	0.00	0.00	0.00	0.00
Hauling	0.00	0.00	0.00	0.00	0.00	0.00	0.00	0.00	0.00	0.00	0.00	—	0.00	0.00	0.00	0.00	0.00	0.00
Average Daily	—	—	—	—	—	—	—	—	—	—	—	—	—	—	—	—	—	—

Worker	0.00	0.00	0.00	0.00	0.00	0.00	0.00	0.00	0.00	0.00	0.00	0.00	—	0.00	0.00	0.00	0.00	0.00	0.00
Vendor	0.00	0.00	0.00	0.00	0.00	0.00	0.00	0.00	0.00	0.00	0.00	0.00	—	0.00	0.00	0.00	0.00	0.00	0.00
Hauling	0.00	0.00	0.00	0.00	0.00	0.00	0.00	0.00	0.00	0.00	0.00	0.00	—	0.00	0.00	0.00	0.00	0.00	0.00
Annual	—	—	—	—	—	—	—	—	—	—	—	—	—	—	—	—	—	—	—
Worker	0.00	0.00	0.00	0.00	0.00	0.00	0.00	0.00	0.00	0.00	0.00	0.00	—	0.00	0.00	0.00	0.00	0.00	0.00
Vendor	0.00	0.00	0.00	0.00	0.00	0.00	0.00	0.00	0.00	0.00	0.00	0.00	—	0.00	0.00	0.00	0.00	0.00	0.00
Hauling	0.00	0.00	0.00	0.00	0.00	0.00	0.00	0.00	0.00	0.00	0.00	0.00	—	0.00	0.00	0.00	0.00	0.00	0.00

3.13. Architectural Coating (2023) - Unmitigated

Criteria Pollutants (lb/day for daily, ton/yr for annual) and GHGs (lb/day for daily, MT/yr for annual)

Location	TOG	ROG	NOx	CO	SO2	PM10E	PM10D	PM10T	PM2.5E	PM2.5D	PM2.5T	BCO2	NBCO2	CO2T	CH4	N2O	R	CO2e
Onsite	—	—	—	—	—	—	—	—	—	—	—	—	—	—	—	—	—	—
Daily, Summer (Max)	—	—	—	—	—	—	—	—	—	—	—	—	—	—	—	—	—	—
Daily, Winter (Max)	—	—	—	—	—	—	—	—	—	—	—	—	—	—	—	—	—	—
Off-Road Equipment	0.18	0.15	0.93	1.15	< 0.005	0.04	—	0.04	0.03	—	0.03	—	134	134	0.01	< 0.005	—	134
Architect ural Coatings	—	117	—	—	—	—	—	—	—	—	—	—	—	—	—	—	—	—
Onsite truck	0.00	0.00	0.00	0.00	0.00	0.00	0.00	0.00	0.00	0.00	0.00	—	0.00	0.00	0.00	0.00	0.00	0.00
Average Daily	—	—	—	—	—	—	—	—	—	—	—	—	—	—	—	—	—	—
Off-Road Equipment	< 0.005	< 0.005	0.01	0.02	< 0.005	< 0.005	—	< 0.005	< 0.005	—	< 0.005	—	1.83	1.83	< 0.005	< 0.005	—	1.84
Architect ural Coatings	—	1.60	—	—	—	—	—	—	—	—	—	—	—	—	—	—	—	—

Onsite truck	0.00	0.00	0.00	0.00	0.00	0.00	0.00	0.00	0.00	0.00	0.00	0.00	—	0.00	0.00	0.00	0.00	0.00	0.00
Annual	—	—	—	—	—	—	—	—	—	—	—	—	—	—	—	—	—	—	—
Off-Road Equipment	< 0.005	< 0.005	< 0.005	< 0.005	< 0.005	< 0.005	—	< 0.005	< 0.005	—	< 0.005	—	0.30	0.30	< 0.005	< 0.005	—	0.30	
Architectural Coatings	—	0.29	—	—	—	—	—	—	—	—	—	—	—	—	—	—	—	—	
Onsite truck	0.00	0.00	0.00	0.00	0.00	0.00	0.00	0.00	0.00	0.00	0.00	—	0.00	0.00	0.00	0.00	0.00	0.00	
Offsite	—	—	—	—	—	—	—	—	—	—	—	—	—	—	—	—	—	—	
Daily, Summer (Max)	—	—	—	—	—	—	—	—	—	—	—	—	—	—	—	—	—	—	
Daily, Winter (Max)	—	—	—	—	—	—	—	—	—	—	—	—	—	—	—	—	—	—	
Worker	0.01	0.01	0.01	0.08	0.00	0.00	< 0.005	< 0.005	0.00	0.00	0.00	—	15.1	15.1	< 0.005	< 0.005	< 0.005	15.3	
Vendor	0.00	0.00	0.00	0.00	0.00	0.00	0.00	0.00	0.00	0.00	0.00	—	0.00	0.00	0.00	0.00	0.00	0.00	
Hauling	0.00	0.00	0.00	0.00	0.00	0.00	0.00	0.00	0.00	0.00	0.00	—	0.00	0.00	0.00	0.00	0.00	0.00	
Average Daily	—	—	—	—	—	—	—	—	—	—	—	—	—	—	—	—	—	—	
Worker	< 0.005	< 0.005	< 0.005	< 0.005	0.00	0.00	< 0.005	< 0.005	0.00	0.00	0.00	—	0.21	0.21	< 0.005	< 0.005	< 0.005	0.21	
Vendor	0.00	0.00	0.00	0.00	0.00	0.00	0.00	0.00	0.00	0.00	0.00	—	0.00	0.00	0.00	0.00	0.00	0.00	
Hauling	0.00	0.00	0.00	0.00	0.00	0.00	0.00	0.00	0.00	0.00	0.00	—	0.00	0.00	0.00	0.00	0.00	0.00	
Annual	—	—	—	—	—	—	—	—	—	—	—	—	—	—	—	—	—	—	
Worker	< 0.005	< 0.005	< 0.005	< 0.005	0.00	0.00	< 0.005	< 0.005	0.00	0.00	0.00	—	0.03	0.03	< 0.005	< 0.005	< 0.005	0.04	
Vendor	0.00	0.00	0.00	0.00	0.00	0.00	0.00	0.00	0.00	0.00	0.00	—	0.00	0.00	0.00	0.00	0.00	0.00	
Hauling	0.00	0.00	0.00	0.00	0.00	0.00	0.00	0.00	0.00	0.00	0.00	—	0.00	0.00	0.00	0.00	0.00	0.00	

4. Operations Emissions Details

4.1. Mobile Emissions by Land Use

4.1.1. Unmitigated

Criteria Pollutants (lb/day for daily, ton/yr for annual) and GHGs (lb/day for daily, MT/yr for annual)

Land Use	TOG	ROG	NOx	CO	SO2	PM10E	PM10D	PM10T	PM2.5E	PM2.5D	PM2.5T	BCO2	NBCO2	CO2T	CH4	N2O	R	CO2e
Daily, Summer (Max)	—	—	—	—	—	—	—	—	—	—	—	—	—	—	—	—	—	—
Condo/Townhouse	1.66	1.60	0.91	6.37	0.01	0.02	0.07	0.08	0.01	0.02	0.04	—	1,205	1,205	0.05	0.06	5.58	1,229
Total	1.66	1.60	0.91	6.37	0.01	0.02	0.07	0.08	0.01	0.02	0.04	—	1,205	1,205	0.05	0.06	5.58	1,229
Daily, Winter (Max)	—	—	—	—	—	—	—	—	—	—	—	—	—	—	—	—	—	—
Condo/Townhouse	1.59	1.52	1.05	5.59	0.01	0.02	0.07	0.08	0.01	0.02	0.04	—	1,120	1,120	0.06	0.06	0.14	1,140
Total	1.59	1.52	1.05	5.59	0.01	0.02	0.07	0.08	0.01	0.02	0.04	—	1,120	1,120	0.06	0.06	0.14	1,140
Annual	—	—	—	—	—	—	—	—	—	—	—	—	—	—	—	—	—	—
Condo/Townhouse	0.25	0.24	0.16	0.91	< 0.005	< 0.005	0.01	0.01	< 0.005	< 0.005	0.01	—	168	168	0.01	0.01	0.36	172
Total	0.25	0.24	0.16	0.91	< 0.005	< 0.005	0.01	0.01	< 0.005	< 0.005	0.01	—	168	168	0.01	0.01	0.36	172

4.2. Energy

4.2.1. Electricity Emissions By Land Use - Unmitigated

Criteria Pollutants (lb/day for daily, ton/yr for annual) and GHGs (lb/day for daily, MT/yr for annual)

Land Use	TOG	ROG	NOx	CO	SO2	PM10E	PM10D	PM10T	PM2.5E	PM2.5D	PM2.5T	BCO2	NBCO2	CO2T	CH4	N2O	R	CO2e
Daily, Summer (Max)	—	—	—	—	—	—	—	—	—	—	—	—	—	—	—	—	—	—
Condo/Townhouse	—	—	—	—	—	—	—	—	—	—	—	—	28.8	28.8	< 0.005	< 0.005	—	29.1
Total	—	—	—	—	—	—	—	—	—	—	—	—	28.8	28.8	< 0.005	< 0.005	—	29.1
Daily, Winter (Max)	—	—	—	—	—	—	—	—	—	—	—	—	—	—	—	—	—	—
Condo/Townhouse	—	—	—	—	—	—	—	—	—	—	—	—	28.8	28.8	< 0.005	< 0.005	—	29.1
Total	—	—	—	—	—	—	—	—	—	—	—	—	28.8	28.8	< 0.005	< 0.005	—	29.1
Annual	—	—	—	—	—	—	—	—	—	—	—	—	—	—	—	—	—	—
Condo/Townhouse	—	—	—	—	—	—	—	—	—	—	—	—	4.77	4.77	< 0.005	< 0.005	—	4.82
Total	—	—	—	—	—	—	—	—	—	—	—	—	4.77	4.77	< 0.005	< 0.005	—	4.82

4.2.3. Natural Gas Emissions By Land Use - Unmitigated

Criteria Pollutants (lb/day for daily, ton/yr for annual) and GHGs (lb/day for daily, MT/yr for annual)

Land Use	TOG	ROG	NOx	CO	SO2	PM10E	PM10D	PM10T	PM2.5E	PM2.5D	PM2.5T	BCO2	NBCO2	CO2T	CH4	N2O	R	CO2e
Daily, Summer (Max)	—	—	—	—	—	—	—	—	—	—	—	—	—	—	—	—	—	—
Condo/Townhouse	0.01	< 0.005	0.06	0.02	< 0.005	< 0.005	—	< 0.005	< 0.005	—	< 0.005	—	74.4	74.4	0.01	< 0.005	—	74.6

Total	0.01	< 0.005	0.06	0.02	< 0.005	< 0.005	—	< 0.005	< 0.005	—	< 0.005	—	74.4	74.4	0.01	< 0.005	—	74.6
Daily, Winter (Max)	—	—	—	—	—	—	—	—	—	—	—	—	—	—	—	—	—	—
Condo/Townhouse	0.01	< 0.005	0.06	0.02	< 0.005	< 0.005	—	< 0.005	< 0.005	—	< 0.005	—	74.4	74.4	0.01	< 0.005	—	74.6
Total	0.01	< 0.005	0.06	0.02	< 0.005	< 0.005	—	< 0.005	< 0.005	—	< 0.005	—	74.4	74.4	0.01	< 0.005	—	74.6
Annual	—	—	—	—	—	—	—	—	—	—	—	—	—	—	—	—	—	—
Condo/Townhouse	< 0.005	< 0.005	0.01	< 0.005	< 0.005	< 0.005	—	< 0.005	< 0.005	—	< 0.005	—	12.3	12.3	< 0.005	< 0.005	—	12.4
Total	< 0.005	< 0.005	0.01	< 0.005	< 0.005	< 0.005	—	< 0.005	< 0.005	—	< 0.005	—	12.3	12.3	< 0.005	< 0.005	—	12.4

4.3. Area Emissions by Source

4.3.2. Unmitigated

Criteria Pollutants (lb/day for daily, ton/yr for annual) and GHGs (lb/day for daily, MT/yr for annual)

Source	TOG	ROG	NOx	CO	SO2	PM10E	PM10D	PM10T	PM2.5E	PM2.5D	PM2.5T	BCO2	NBCO2	CO2T	CH4	N2O	R	CO2e
Daily, Summer (Max)	—	—	—	—	—	—	—	—	—	—	—	—	—	—	—	—	—	—
Hearths	15.6	15.3	0.30	18.9	0.03	2.60	—	2.60	2.59	—	2.59	278	116	394	0.26	0.02	—	406
Consumer Products	—	0.40	—	—	—	—	—	—	—	—	—	—	—	—	—	—	—	—
Architectural Coatings	—	0.16	—	—	—	—	—	—	—	—	—	—	—	—	—	—	—	—
Landscape Equipment	0.06	0.05	0.01	0.56	< 0.005	< 0.005	—	< 0.005	< 0.005	—	< 0.005	—	1.52	1.52	< 0.005	< 0.005	—	1.52

Total	15.6	15.9	0.30	19.5	0.03	2.60	—	2.60	2.59	—	2.59	278	117	395	0.26	0.02	—	407
Daily, Winter (Max)	—	—	—	—	—	—	—	—	—	—	—	—	—	—	—	—	—	—
Architectural Coatings	—	117	—	—	—	—	—	—	—	—	—	—	—	—	—	—	—	—
Hearths	15.6	15.3	0.30	18.9	0.03	2.60	—	2.60	2.59	—	2.59	278	116	394	0.26	0.02	—	406
Consumer Products	—	0.40	—	—	—	—	—	—	—	—	—	—	—	—	—	—	—	—
Total	15.6	132	0.30	18.9	0.03	2.60	—	2.60	2.59	—	2.59	278	116	394	0.26	0.02	—	406
Annual	—	—	—	—	—	—	—	—	—	—	—	—	—	—	—	—	—	—
Architectural Coatings	—	0.32	—	—	—	—	—	—	—	—	—	—	—	—	—	—	—	—
Hearths	0.64	0.63	0.01	0.77	< 0.005	0.11	—	0.11	0.11	—	0.11	10.3	4.31	14.6	0.01	< 0.005	—	15.1
Consumer Products	—	0.07	—	—	—	—	—	—	—	—	—	—	—	—	—	—	—	—
Landscape Equipment	0.01	< 0.005	< 0.005	0.05	< 0.005	< 0.005	—	< 0.005	< 0.005	—	< 0.005	—	0.12	0.12	< 0.005	< 0.005	—	0.12
Total	0.64	1.03	0.01	0.83	< 0.005	0.11	—	0.11	0.11	—	0.11	10.3	4.43	14.8	0.01	< 0.005	—	15.2

4.4. Water Emissions by Land Use

4.4.2. Unmitigated

Criteria Pollutants (lb/day for daily, ton/yr for annual) and GHGs (lb/day for daily, MT/yr for annual)

Land Use	TOG	ROG	NOx	CO	SO2	PM10E	PM10D	PM10T	PM2.5E	PM2.5D	PM2.5T	BCO2	NBCO2	CO2T	CH4	N2O	R	CO2e
----------	-----	-----	-----	----	-----	-------	-------	-------	--------	--------	--------	------	-------	------	-----	-----	---	------

Daily, Summer (Max)	—	—	—	—	—	—	—	—	—	—	—	—	—	—	—	—	—	—
Condo/Townhouse	—	—	—	—	—	—	—	—	—	—	—	0.61	0.68	1.29	0.06	< 0.005	—	3.31
Total	—	—	—	—	—	—	—	—	—	—	—	0.61	0.68	1.29	0.06	< 0.005	—	3.31
Daily, Winter (Max)	—	—	—	—	—	—	—	—	—	—	—	—	—	—	—	—	—	—
Condo/Townhouse	—	—	—	—	—	—	—	—	—	—	—	0.61	0.68	1.29	0.06	< 0.005	—	3.31
Total	—	—	—	—	—	—	—	—	—	—	—	0.61	0.68	1.29	0.06	< 0.005	—	3.31
Annual	—	—	—	—	—	—	—	—	—	—	—	—	—	—	—	—	—	—
Condo/Townhouse	—	—	—	—	—	—	—	—	—	—	—	0.10	0.11	0.21	0.01	< 0.005	—	0.55
Total	—	—	—	—	—	—	—	—	—	—	—	0.10	0.11	0.21	0.01	< 0.005	—	0.55

4.5. Waste Emissions by Land Use

4.5.2. Unmitigated

Criteria Pollutants (lb/day for daily, ton/yr for annual) and GHGs (lb/day for daily, MT/yr for annual)

Land Use	TOG	ROG	NOx	CO	SO2	PM10E	PM10D	PM10T	PM2.5E	PM2.5D	PM2.5T	BCO2	NBCO2	CO2T	CH4	N2O	R	CO2e
Daily, Summer (Max)	—	—	—	—	—	—	—	—	—	—	—	—	—	—	—	—	—	—
Condo/Townhouse	—	—	—	—	—	—	—	—	—	—	—	1.57	0.00	1.57	0.16	0.00	—	5.49
Total	—	—	—	—	—	—	—	—	—	—	—	1.57	0.00	1.57	0.16	0.00	—	5.49

Daily, Winter (Max)	—	—	—	—	—	—	—	—	—	—	—	—	—	—	—	—	—	—
Condo/Townhouse	—	—	—	—	—	—	—	—	—	—	—	1.57	0.00	1.57	0.16	0.00	—	5.49
Total	—	—	—	—	—	—	—	—	—	—	—	1.57	0.00	1.57	0.16	0.00	—	5.49
Annual	—	—	—	—	—	—	—	—	—	—	—	—	—	—	—	—	—	—
Condo/Townhouse	—	—	—	—	—	—	—	—	—	—	—	0.26	0.00	0.26	0.03	0.00	—	0.91
Total	—	—	—	—	—	—	—	—	—	—	—	0.26	0.00	0.26	0.03	0.00	—	0.91

4.6. Refrigerant Emissions by Land Use

4.6.1. Unmitigated

Criteria Pollutants (lb/day for daily, ton/yr for annual) and GHGs (lb/day for daily, MT/yr for annual)

Land Use	TOG	ROG	NOx	CO	SO2	PM10E	PM10D	PM10T	PM2.5E	PM2.5D	PM2.5T	BCO2	NBCO2	CO2T	CH4	N2O	R	CO2e
Daily, Summer (Max)	—	—	—	—	—	—	—	—	—	—	—	—	—	—	—	—	—	—
Condo/Townhouse	—	—	—	—	—	—	—	—	—	—	—	—	—	—	—	—	0.13	0.13
Total	—	—	—	—	—	—	—	—	—	—	—	—	—	—	—	—	0.13	0.13
Daily, Winter (Max)	—	—	—	—	—	—	—	—	—	—	—	—	—	—	—	—	—	—
Condo/Townhouse	—	—	—	—	—	—	—	—	—	—	—	—	—	—	—	—	0.13	0.13
Total	—	—	—	—	—	—	—	—	—	—	—	—	—	—	—	—	0.13	0.13

Annual	—	—	—	—	—	—	—	—	—	—	—	—	—	—	—	—	—	—	
Condo/Townhouse	—	—	—	—	—	—	—	—	—	—	—	—	—	—	—	—	—	0.02	0.02
Total	—	—	—	—	—	—	—	—	—	—	—	—	—	—	—	—	—	0.02	0.02

4.7. Offroad Emissions By Equipment Type

4.7.1. Unmitigated

Criteria Pollutants (lb/day for daily, ton/yr for annual) and GHGs (lb/day for daily, MT/yr for annual)

Equipment Type	TOG	ROG	NOx	CO	SO2	PM10E	PM10D	PM10T	PM2.5E	PM2.5D	PM2.5T	BCO2	NBCO2	CO2T	CH4	N2O	R	CO2e
Daily, Summer (Max)	—	—	—	—	—	—	—	—	—	—	—	—	—	—	—	—	—	—
Total	—	—	—	—	—	—	—	—	—	—	—	—	—	—	—	—	—	—
Daily, Winter (Max)	—	—	—	—	—	—	—	—	—	—	—	—	—	—	—	—	—	—
Total	—	—	—	—	—	—	—	—	—	—	—	—	—	—	—	—	—	—
Annual	—	—	—	—	—	—	—	—	—	—	—	—	—	—	—	—	—	—
Total	—	—	—	—	—	—	—	—	—	—	—	—	—	—	—	—	—	—

4.8. Stationary Emissions By Equipment Type

4.8.1. Unmitigated

Criteria Pollutants (lb/day for daily, ton/yr for annual) and GHGs (lb/day for daily, MT/yr for annual)

Equipment Type	TOG	ROG	NOx	CO	SO2	PM10E	PM10D	PM10T	PM2.5E	PM2.5D	PM2.5T	BCO2	NBCO2	CO2T	CH4	N2O	R	CO2e
----------------	-----	-----	-----	----	-----	-------	-------	-------	--------	--------	--------	------	-------	------	-----	-----	---	------

Daily, Summer (Max)	—	—	—	—	—	—	—	—	—	—	—	—	—	—	—	—	—	—
Total	—	—	—	—	—	—	—	—	—	—	—	—	—	—	—	—	—	—
Daily, Winter (Max)	—	—	—	—	—	—	—	—	—	—	—	—	—	—	—	—	—	—
Total	—	—	—	—	—	—	—	—	—	—	—	—	—	—	—	—	—	—
Annual	—	—	—	—	—	—	—	—	—	—	—	—	—	—	—	—	—	—
Total	—	—	—	—	—	—	—	—	—	—	—	—	—	—	—	—	—	—

4.9. User Defined Emissions By Equipment Type

4.9.1. Unmitigated

Criteria Pollutants (lb/day for daily, ton/yr for annual) and GHGs (lb/day for daily, MT/yr for annual)

Equipment Type	TOG	ROG	NOx	CO	SO2	PM10E	PM10D	PM10T	PM2.5E	PM2.5D	PM2.5T	BCO2	NBCO2	CO2T	CH4	N2O	R	CO2e
Daily, Summer (Max)	—	—	—	—	—	—	—	—	—	—	—	—	—	—	—	—	—	—
Total	—	—	—	—	—	—	—	—	—	—	—	—	—	—	—	—	—	—
Daily, Winter (Max)	—	—	—	—	—	—	—	—	—	—	—	—	—	—	—	—	—	—
Total	—	—	—	—	—	—	—	—	—	—	—	—	—	—	—	—	—	—
Annual	—	—	—	—	—	—	—	—	—	—	—	—	—	—	—	—	—	—
Total	—	—	—	—	—	—	—	—	—	—	—	—	—	—	—	—	—	—

4.10. Soil Carbon Accumulation By Vegetation Type

4.10.1. Soil Carbon Accumulation By Vegetation Type - Unmitigated

Criteria Pollutants (lb/day for daily, ton/yr for annual) and GHGs (lb/day for daily, MT/yr for annual)

Vegetation	TOG	ROG	NOx	CO	SO2	PM10E	PM10D	PM10T	PM2.5E	PM2.5D	PM2.5T	BCO2	NBCO2	CO2T	CH4	N2O	R	CO2e
Daily, Summer (Max)	—	—	—	—	—	—	—	—	—	—	—	—	—	—	—	—	—	—
Total	—	—	—	—	—	—	—	—	—	—	—	—	—	—	—	—	—	—
Daily, Winter (Max)	—	—	—	—	—	—	—	—	—	—	—	—	—	—	—	—	—	—
Total	—	—	—	—	—	—	—	—	—	—	—	—	—	—	—	—	—	—
Annual	—	—	—	—	—	—	—	—	—	—	—	—	—	—	—	—	—	—
Total	—	—	—	—	—	—	—	—	—	—	—	—	—	—	—	—	—	—

4.10.2. Above and Belowground Carbon Accumulation by Land Use Type - Unmitigated

Criteria Pollutants (lb/day for daily, ton/yr for annual) and GHGs (lb/day for daily, MT/yr for annual)

Land Use	TOG	ROG	NOx	CO	SO2	PM10E	PM10D	PM10T	PM2.5E	PM2.5D	PM2.5T	BCO2	NBCO2	CO2T	CH4	N2O	R	CO2e
Daily, Summer (Max)	—	—	—	—	—	—	—	—	—	—	—	—	—	—	—	—	—	—
Total	—	—	—	—	—	—	—	—	—	—	—	—	—	—	—	—	—	—
Daily, Winter (Max)	—	—	—	—	—	—	—	—	—	—	—	—	—	—	—	—	—	—
Total	—	—	—	—	—	—	—	—	—	—	—	—	—	—	—	—	—	—
Annual	—	—	—	—	—	—	—	—	—	—	—	—	—	—	—	—	—	—
Total	—	—	—	—	—	—	—	—	—	—	—	—	—	—	—	—	—	—

4.10.3. Avoided and Sequestered Emissions by Species - Unmitigated

Criteria Pollutants (lb/day for daily, ton/yr for annual) and GHGs (lb/day for daily, MT/yr for annual)

Species	TOG	ROG	NOx	CO	SO2	PM10E	PM10D	PM10T	PM2.5E	PM2.5D	PM2.5T	BCO2	NBCO2	CO2T	CH4	N2O	R	CO2e
Daily, Summer (Max)	—	—	—	—	—	—	—	—	—	—	—	—	—	—	—	—	—	—
Avoided	—	—	—	—	—	—	—	—	—	—	—	—	—	—	—	—	—	—
Subtotal	—	—	—	—	—	—	—	—	—	—	—	—	—	—	—	—	—	—
Sequestered	—	—	—	—	—	—	—	—	—	—	—	—	—	—	—	—	—	—
Subtotal	—	—	—	—	—	—	—	—	—	—	—	—	—	—	—	—	—	—
Removed	—	—	—	—	—	—	—	—	—	—	—	—	—	—	—	—	—	—
Subtotal	—	—	—	—	—	—	—	—	—	—	—	—	—	—	—	—	—	—
—	—	—	—	—	—	—	—	—	—	—	—	—	—	—	—	—	—	—
Daily, Winter (Max)	—	—	—	—	—	—	—	—	—	—	—	—	—	—	—	—	—	—
Avoided	—	—	—	—	—	—	—	—	—	—	—	—	—	—	—	—	—	—
Subtotal	—	—	—	—	—	—	—	—	—	—	—	—	—	—	—	—	—	—
Sequestered	—	—	—	—	—	—	—	—	—	—	—	—	—	—	—	—	—	—
Subtotal	—	—	—	—	—	—	—	—	—	—	—	—	—	—	—	—	—	—
Removed	—	—	—	—	—	—	—	—	—	—	—	—	—	—	—	—	—	—
Subtotal	—	—	—	—	—	—	—	—	—	—	—	—	—	—	—	—	—	—
—	—	—	—	—	—	—	—	—	—	—	—	—	—	—	—	—	—	—
Annual	—	—	—	—	—	—	—	—	—	—	—	—	—	—	—	—	—	—
Avoided	—	—	—	—	—	—	—	—	—	—	—	—	—	—	—	—	—	—
Subtotal	—	—	—	—	—	—	—	—	—	—	—	—	—	—	—	—	—	—

Sequest	—	—	—	—	—	—	—	—	—	—	—	—	—	—	—	—	—	—
Subtotal	—	—	—	—	—	—	—	—	—	—	—	—	—	—	—	—	—	—
Remove d	—	—	—	—	—	—	—	—	—	—	—	—	—	—	—	—	—	—
Subtotal	—	—	—	—	—	—	—	—	—	—	—	—	—	—	—	—	—	—
—	—	—	—	—	—	—	—	—	—	—	—	—	—	—	—	—	—	—

5. Activity Data

5.1. Construction Schedule

Phase Name	Phase Type	Start Date	End Date	Days Per Week	Work Days per Phase	Phase Description
Demolition	Demolition	9/1/2022	9/15/2022	5.00	10.0	—
Site Preparation	Site Preparation	9/16/2022	9/17/2022	5.00	1.00	—
Grading	Grading	9/18/2022	9/20/2022	5.00	2.00	—
Building Construction	Building Construction	9/21/2022	2/8/2023	5.00	100	—
Paving	Paving	2/9/2023	2/16/2023	5.00	5.00	—
Architectural Coating	Architectural Coating	2/17/2023	2/24/2023	5.00	5.00	—

5.2. Off-Road Equipment

5.2.1. Unmitigated

Phase Name	Equipment Type	Fuel Type	Engine Tier	Number per Day	Hours Per Day	Horsepower	Load Factor
Demolition	Concrete/Industrial Saws	Diesel	Average	1.00	8.00	33.0	0.73
Demolition	Rubber Tired Dozers	Diesel	Average	1.00	1.00	367	0.40
Demolition	Tractors/Loaders/Backhoes	Diesel	Average	2.00	6.00	84.0	0.37
Site Preparation	Graders	Diesel	Average	1.00	8.00	148	0.41

Site Preparation	Tractors/Loaders/Backhoes	Diesel	Average	1.00	8.00	84.0	0.37
Grading	Graders	Diesel	Average	1.00	6.00	148	0.41
Grading	Rubber Tired Dozers	Diesel	Average	1.00	6.00	367	0.40
Grading	Tractors/Loaders/Backhoes	Diesel	Average	1.00	7.00	84.0	0.37
Building Construction	Cranes	Diesel	Average	1.00	4.00	367	0.29
Building Construction	Forklifts	Diesel	Average	2.00	6.00	82.0	0.20
Building Construction	Tractors/Loaders/Backhoes	Diesel	Average	2.00	8.00	84.0	0.37
Paving	Cement and Mortar Mixers	Diesel	Average	4.00	6.00	10.0	0.56
Paving	Pavers	Diesel	Average	1.00	7.00	81.0	0.42
Paving	Rollers	Diesel	Average	1.00	7.00	36.0	0.38
Paving	Tractors/Loaders/Backhoes	Diesel	Average	1.00	7.00	84.0	0.37
Architectural Coating	Air Compressors	Diesel	Average	1.00	6.00	37.0	0.48

5.3. Construction Vehicles

5.3.1. Unmitigated

Phase Name	Trip Type	One-Way Trips per Day	Miles per Trip	Vehicle Mix
Demolition	—	—	—	—
Demolition	Worker	0.00	14.3	LDA,LDT1,LDT2
Demolition	Vendor	—	8.80	HHDT,MHDT
Demolition	Hauling	0.00	20.0	HHDT
Demolition	Onsite truck	—	—	HHDT
Site Preparation	—	—	—	—
Site Preparation	Worker	0.00	14.3	LDA,LDT1,LDT2
Site Preparation	Vendor	—	8.80	HHDT,MHDT

Site Preparation	Hauling	0.00	20.0	HHDT
Site Preparation	Onsite truck	—	—	HHDT
Grading	—	—	—	—
Grading	Worker	0.00	14.3	LDA,LDT1,LDT2
Grading	Vendor	—	8.80	HHDT,MHDT
Grading	Hauling	0.00	20.0	HHDT
Grading	Onsite truck	—	—	HHDT
Building Construction	—	—	—	—
Building Construction	Worker	7.20	14.3	LDA,LDT1,LDT2
Building Construction	Vendor	1.07	8.80	HHDT,MHDT
Building Construction	Hauling	0.00	20.0	HHDT
Building Construction	Onsite truck	—	—	HHDT
Paving	—	—	—	—
Paving	Worker	0.00	14.3	LDA,LDT1,LDT2
Paving	Vendor	—	8.80	HHDT,MHDT
Paving	Hauling	0.00	20.0	HHDT
Paving	Onsite truck	—	—	HHDT
Architectural Coating	—	—	—	—
Architectural Coating	Worker	1.44	14.3	LDA,LDT1,LDT2
Architectural Coating	Vendor	—	8.80	HHDT,MHDT
Architectural Coating	Hauling	0.00	20.0	HHDT
Architectural Coating	Onsite truck	—	—	HHDT

5.4. Vehicles

5.4.1. Construction Vehicle Control Strategies

Non-applicable. No control strategies activated by user.

5.5. Architectural Coatings

Phase Name	Residential Interior Area Coated (sq ft)	Residential Exterior Area Coated (sq ft)	Non-Residential Interior Area Coated (sq ft)	Non-Residential Exterior Area Coated (sq ft)	Parking Area Coated (sq ft)
Architectural Coating	37,706	12,569	0.00	0.00	—

5.6. Dust Mitigation

5.6.1. Construction Earthmoving Activities

Phase Name	Material Imported (cy)	Material Exported (cy)	Acres Graded (acres)	Material Demolished (sq. ft.)	Acres Paved (acres)
Demolition	0.00	0.00	0.00	—	—
Site Preparation	—	—	0.50	0.00	—
Grading	—	—	1.50	0.00	—
Paving	0.00	0.00	0.00	0.00	—

5.6.2. Construction Earthmoving Control Strategies

Non-applicable. No control strategies activated by user.

5.7. Construction Paving

Land Use	Area Paved (acres)	% Asphalt
Condo/Townhouse	—	0%

5.8. Construction Electricity Consumption and Emissions Factors

kWh per Year and Emission Factor (lb/MWh)

Year	kWh per Year	CO2	CH4	N2O
2022	0.00	204	0.03	< 0.005
2023	0.00	204	0.03	< 0.005

5.9. Operational Mobile Sources

5.9.1. Unmitigated

Land Use Type	Trips/Weekday	Trips/Saturday	Trips/Sunday	Trips/Year	VMT/Weekday	VMT/Saturday	VMT/Sunday	VMT/Year
Condo/Townhouse	73.2	81.4	62.8	26,603	1,118	1,244	959	406,418

5.10. Operational Area Sources

5.10.1. Hearths

5.10.1.1. Unmitigated

Hearth Type	Unmitigated (number)
Condo/Townhouse	—
Wood Fireplaces	4
Gas Fireplaces	6
Propane Fireplaces	0
Electric Fireplaces	0
No Fireplaces	1
Conventional Wood Stoves	0
Catalytic Wood Stoves	1
Non-Catalytic Wood Stoves	1
Pellet Wood Stoves	0

5.10.2. Architectural Coatings

Residential Interior Area Coated (sq ft)	Residential Exterior Area Coated (sq ft)	Non-Residential Interior Area Coated (sq ft)	Non-Residential Exterior Area Coated (sq ft)	Parking Area Coated (sq ft)
37705.5	12,569	0.00	0.00	—

5.10.3. Landscape Equipment

Season	Unit	Value
Snow Days	day/yr	0.00
Summer Days	day/yr	180

5.11. Operational Energy Consumption

5.11.1. Unmitigated

Electricity (kWh/yr) and CO2 and CH4 and N2O and Natural Gas (kBTU/yr)

Land Use	Electricity (kWh/yr)	CO2	CH4	N2O	Natural Gas (kBTU/yr)
Condo/Townhouse	51,592	204	0.0330	0.0040	232,199

5.12. Operational Water and Wastewater Consumption

5.12.1. Unmitigated

Land Use	Indoor Water (gal/year)	Outdoor Water (gal/year)
Condo/Townhouse	319,850	131,166

5.13. Operational Waste Generation

5.13.1. Unmitigated

Land Use	Waste (ton/year)	Cogeneration (kWh/year)
Condo/Townhouse	2.91	0.00

5.14. Operational Refrigeration and Air Conditioning Equipment

5.14.1. Unmitigated

Land Use Type	Equipment Type	Refrigerant	GWP	Quantity (kg)	Operations Leak Rate	Service Leak Rate	Times Serviced
Condo/Townhouse	Average room A/C & Other residential A/C and heat pumps	R-410A	2,088	< 0.005	2.50	2.50	10.0
Condo/Townhouse	Household refrigerators and/or freezers	R-134a	1,430	0.12	0.60	0.00	1.00

5.15. Operational Off-Road Equipment

5.15.1. Unmitigated

Equipment Type	Fuel Type	Engine Tier	Number per Day	Hours Per Day	Horsepower	Load Factor
----------------	-----------	-------------	----------------	---------------	------------	-------------

5.16. Stationary Sources

5.16.1. Emergency Generators and Fire Pumps

Equipment Type	Fuel Type	Number per Day	Hours per Day	Hours per Year	Horsepower	Load Factor
----------------	-----------	----------------	---------------	----------------	------------	-------------

5.16.2. Process Boilers

Equipment Type	Fuel Type	Number	Boiler Rating (MMBtu/hr)	Daily Heat Input (MMBtu/day)	Annual Heat Input (MMBtu/yr)
----------------	-----------	--------	--------------------------	------------------------------	------------------------------

5.17. User Defined

Equipment Type	Fuel Type
—	—

5.18. Vegetation

5.18.1. Land Use Change

5.18.1.1. Unmitigated

Vegetation Land Use Type	Vegetation Soil Type	Initial Acres	Final Acres
--------------------------	----------------------	---------------	-------------

5.18.1. Biomass Cover Type

5.18.1.1. Unmitigated

Biomass Cover Type	Initial Acres	Final Acres
--------------------	---------------	-------------

5.18.2. Sequestration

5.18.2.1. Unmitigated

Tree Type	Number	Electricity Saved (kWh/year)	Natural Gas Saved (btu/year)
-----------	--------	------------------------------	------------------------------

6. Climate Risk Detailed Report

6.1. Climate Risk Summary

Cal-Adapt midcentury 2040–2059 average projections for four hazards are reported below for your project location. These are under Representation Concentration Pathway (RCP) 8.5 which assumes GHG emissions will continue to rise strongly through 2050 and then plateau around 2100.

Climate Hazard	Result for Project Location	Unit
Temperature and Extreme Heat	29.9	annual days of extreme heat
Extreme Precipitation	9.30	annual days with precipitation above 20 mm
Sea Level Rise	0.00	meters of inundation depth
Wildfire	9.60	annual hectares burned

Temperature and Extreme Heat data are for grid cell in which your project are located. The projection is based on the 98th historical percentile of daily maximum/minimum temperatures from observed historical data (32 climate model ensemble from Cal-Adapt, 2040–2059 average under RCP 8.5). Each grid cell is 6 kilometers (km) by 6 km, or 3.7 miles (mi) by 3.7 mi.

Extreme Precipitation data are for the grid cell in which your project are located. The threshold of 20 mm is equivalent to about $\frac{3}{4}$ an inch of rain, which would be light to moderate rainfall if received over a full day or heavy rain if received over a period of 2 to 4 hours. Each grid cell is 6 kilometers (km) by 6 km, or 3.7 miles (mi) by 3.7 mi.

Sea Level Rise data are for the grid cell in which your project are located. The projections are from Radke et al. (2017), as reported in Cal-Adapt (2040–2059 average under RCP 8.5), and consider different increments of sea level rise coupled with extreme storm events. Users may select from four model simulations to view the range in potential inundation depth for the grid cell. The four simulations make different assumptions about expected rainfall and temperature are: Warmer/drier (HadGEM2-ES), Cooler/wetter (CNRM-CM5), Average conditions (CanESM2), Range of different rainfall and temperature possibilities (MIROC5). Each grid cell is 50 meters (m) by 50 m, or about 164 feet (ft) by 164 ft.

Wildfire data are for the grid cell in which your project are located. The projections are from UC Davis, as reported in Cal-Adapt (2040–2059 average under RCP 8.5), and consider historical data of climate, vegetation, population density, and large (> 400 ha) fire history. Users may select from four model simulations to view the range in potential wildfire probabilities for the grid cell. The four simulations make different assumptions about expected rainfall and temperature are: Warmer/drier (HadGEM2-ES), Cooler/wetter (CNRM-CM5), Average conditions (CanESM2), Range of different rainfall and temperature possibilities (MIROC5). Each grid cell is 6 kilometers (km) by 6 km, or 3.7 miles (mi) by 3.7 mi.

6.2. Initial Climate Risk Scores

Climate Hazard	Exposure Score	Sensitivity Score	Adaptive Capacity Score	Vulnerability Score
Temperature and Extreme Heat	N/A	N/A	N/A	N/A
Extreme Precipitation	2	0	0	N/A
Sea Level Rise	N/A	N/A	N/A	N/A
Wildfire	1	0	0	N/A
Flooding	N/A	N/A	N/A	N/A
Drought	N/A	N/A	N/A	N/A
Snowpack	0	0	0	N/A
Air Quality	N/A	N/A	N/A	N/A

The sensitivity score reflects the extent to which a project would be adversely affected by exposure to a climate hazard. Exposure is rated on a scale of 1 to 5, with a score of 5 representing the greatest exposure.

The adaptive capacity of a project refers to its ability to manage and reduce vulnerabilities from projected climate hazards. Adaptive capacity is rated on a scale of 1 to 5, with a score of 5 representing the greatest ability to adapt.

The overall vulnerability scores are calculated based on the potential impacts and adaptive capacity assessments for each hazard. Scores do not include implementation of climate risk reduction measures.

6.3. Adjusted Climate Risk Scores

Climate Hazard	Exposure Score	Sensitivity Score	Adaptive Capacity Score	Vulnerability Score
Temperature and Extreme Heat	N/A	N/A	N/A	N/A
Extreme Precipitation	2	1	1	3
Sea Level Rise	N/A	N/A	N/A	N/A
Wildfire	1	1	1	2

Flooding	N/A	N/A	N/A	N/A
Drought	N/A	N/A	N/A	N/A
Snowpack	1	1	1	2
Air Quality	N/A	N/A	N/A	N/A

The sensitivity score reflects the extent to which a project would be adversely affected by exposure to a climate hazard. Exposure is rated on a scale of 1 to 5, with a score of 5 representing the greatest exposure.

The adaptive capacity of a project refers to its ability to manage and reduce vulnerabilities from projected climate hazards. Adaptive capacity is rated on a scale of 1 to 5, with a score of 5 representing the greatest ability to adapt.

The overall vulnerability scores are calculated based on the potential impacts and adaptive capacity assessments for each hazard. Scores include implementation of climate risk reduction measures.

6.4. Climate Risk Reduction Measures

7. Health and Equity Details

7.1. CalEnviroScreen 4.0 Scores

The maximum CalEnviroScreen score is 100. A high score (i.e., greater than 50) reflects a higher pollution burden compared to other census tracts in the state.

Indicator	Result for Project Census Tract
Exposure Indicators	—
AQ-Ozone	76.9
AQ-PM	17.7
AQ-DPM	14.3
Drinking Water	15.7
Lead Risk Housing	5.20
Pesticides	0.00
Toxic Releases	14.0
Traffic	32.4
Effect Indicators	—
CleanUp Sites	0.00
Groundwater	22.1

Haz Waste Facilities/Generators	0.00
Impaired Water Bodies	0.00
Solid Waste	0.00
Sensitive Population	—
Asthma	33.3
Cardio-vascular	29.8
Low Birth Weights	2.22
Socioeconomic Factor Indicators	—
Education	10.8
Housing	18.5
Linguistic	13.3
Poverty	6.73
Unemployment	48.3

7.2. Healthy Places Index Scores

The maximum Health Places Index score is 100. A high score (i.e., greater than 50) reflects healthier community conditions compared to other census tracts in the state.

Indicator	Result for Project Census Tract
Economic	—
Above Poverty	89.72154498
Employed	55.33170794
Education	—
Bachelor's or higher	62.20967535
High school enrollment	100
Preschool enrollment	87.10381111
Transportation	—
Auto Access	59.70742974
Active commuting	24.84280765

Social	—
2-parent households	23.09765174
Voting	88.11754138
Neighborhood	—
Alcohol availability	81.8298473
Park access	43.6160657
Retail density	31.90042346
Supermarket access	2.399589375
Tree canopy	94.30257924
Housing	—
Homeownership	82.0993199
Housing habitability	97.60041062
Low-inc homeowner severe housing cost burden	89.74720903
Low-inc renter severe housing cost burden	95.534454
Uncrowded housing	86.21840113
Health Outcomes	—
Insured adults	96.29154369
Arthritis	0.0
Asthma ER Admissions	70.2
High Blood Pressure	0.0
Cancer (excluding skin)	0.0
Asthma	0.0
Coronary Heart Disease	0.0
Chronic Obstructive Pulmonary Disease	0.0
Diagnosed Diabetes	0.0
Life Expectancy at Birth	64.9
Cognitively Disabled	94.6

Physically Disabled	77.4
Heart Attack ER Admissions	47.8
Mental Health Not Good	0.0
Chronic Kidney Disease	0.0
Obesity	0.0
Pedestrian Injuries	19.6
Physical Health Not Good	0.0
Stroke	0.0
Health Risk Behaviors	—
Binge Drinking	0.0
Current Smoker	0.0
No Leisure Time for Physical Activity	0.0
Climate Change Exposures	—
Wildfire Risk	0.0
SLR Inundation Area	0.0
Children	90.2
Elderly	46.6
English Speaking	98.1
Foreign-born	3.8
Outdoor Workers	72.4
Climate Change Adaptive Capacity	—
Impervious Surface Cover	87.1
Traffic Density	48.5
Traffic Access	0.0
Other Indices	—
Hardship	27.4
Other Decision Support	—

2016 Voting	80.4
-------------	------

7.3. Overall Health & Equity Scores

Metric	Result for Project Census Tract
CalEnviroScreen 4.0 Score for Project Location (a)	2.00
Healthy Places Index Score for Project Location (b)	84.0
Project Located in a Designated Disadvantaged Community (Senate Bill 535)	No
Project Located in a Low-Income Community (Assembly Bill 1550)	No
Project Located in a Community Air Protection Program Community (Assembly Bill 617)	No

a: The maximum CalEnviroScreen score is 100. A high score (i.e., greater than 50) reflects a higher pollution burden compared to other census tracts in the state.

b: The maximum Health Places Index score is 100. A high score (i.e., greater than 50) reflects healthier community conditions compared to other census tracts in the state.

7.4. Health & Equity Measures

No Health & Equity Measures selected.

7.5. Evaluation Scorecard

Health and Equity Evaluation Scorecard not completed.

8. User Changes to Default Data



California Tree and Landscape Consulting, Inc.

2021 OCT 22 AM 8:30

RECEIVED
PLANNING DEPARTMENT

Arborist Report

August 28, 2021

Mr. Joe Jaoudi
Cameron Glen Estates, LLC
2216 Via Subria
Vista, CA 92084
Email: josjoudi@aol.com
(760) 664-7196

Work location
2545 Greenwood Lane
Cameron Park, CA 95682

Arborist Report for Oak Woodland Resources

APN:
082-411-004-000

Prepared by:
Gordon Mann, Consulting Arborist

FILE COPY

359 Nevada Street, Suite 201, Auburn, CA 95603 www.caltlc.com office: (530) 745-4086 Direct: (650) 740-3461

Arborist Disclosure Statement

Arborists are tree specialists who use their education, knowledge, training and experience to examine trees, recommend measures to enhance the beauty and health of trees, and attempt to reduce the risk of living near trees. Clients may choose to accept or disregard the recommendations of the arborist, or to seek additional advice.

Arborists cannot detect every condition that could possibly lead to the structural failure of a tree. Trees are living organisms that fail in ways we do not fully understand. Conditions are often hidden within trees and below ground. Arborists cannot guarantee that a tree will be healthy or safe under all circumstances, or for a specified period of time. Likewise, remedial treatments, like any medicine, cannot be guaranteed.

Treatment, pruning and removal of trees may involve considerations beyond the scope of the arborist's services such as property boundaries, property ownership, site lines, disputes between neighbors, and other issues. Arborists cannot take such considerations into account unless complete and accurate information is disclosed to the arborist. An arborist should then be expected to reasonably rely upon the completeness and accuracy of the information provided.

Trees can be managed, but they cannot be controlled. To live near trees is to accept some degree of risk. The only way to eliminate all risk associated with trees is to eliminate all trees.

Summary

The property is 0.88 acres vacant parcel located at 2545 Greenwood Lane, Cameron Park. There is a proposed development with 10 lots on the parcel. The site is a parcel with remnant oak woodland that is connected to remaining remnant oak woodland trees on adjacent parcels consisting of a school and commercial properties. The woodland is 0.512 acres of the 0.88 acre site, or 58.2%. The proposed oak impact is to remove 0.468 acres or 91.4% of the oak woodland.

The oaks on the site are considered a remnant oak woodland with no individual trees. There were 2 trees 24 inches in diameter and greater on the subject property, 1 tree 24 inches and greater diameter on the adjacent property to the west, and no heritage trees 36 inches in diameter or greater.

Mitigation is based on the removal of 0.468 acres of oak woodland at a 2:1 ratio, for a total acre mitigation amount of 0.936 acres at the cost of \$8,285 per acre, for a total mitigation of \$7,638.77.

Assignment

The subject property is an approximately 0.88 acres undeveloped parcel adjacent to a school and commercial properties. The site is on the west side of the street. 10 units are proposed to be constructed on the property.

The client contacted our office on July 30, 2021, provided a site plan, and requested we provide the inspection and report required to satisfy the County of El Dorado's Oak Woodland Resources, determining the oak woodland area, identifying all native oak trees in the woodland area 24 inches in diameter and greater, all Heritage Trees 36 inches in diameter and greater, and any individual oak

trees 6 inches and greater located outside of the woodland designation for tree removal and will need mitigation based on the County ORMP Oak Resources requirements and Ordinance No. 5061. This report is the result of onsite inspections performed on August 2, 2021, and the use of aerial imagery.

Assignment limits

The canopy cover was calculated based on recent aerial imagery. All the trees were observed and verified while standing on the ground. Data collected is limited to a visual ground inspection. Ground inspections and measurements were used to ensure the accuracy of the inspection data.

Current Existing Tree Status (general)

The site is a rectangular shaped lot, approximately 0.88 acres in size. The development is required to comply with the El Dorado County ORMP Oak Resources requirements and Ordinance No. 5061.

The site contains 8 trees 4 Blue Oak (*Quercus douglasii*), and 4 Valley Oak (*Quercus lobata*) on the site. There is one Blue Oak on the adjacent property to the west extending into the site. There is approximately 16% oak canopy on the site, which meets the definition of an oak woodland with at least 48.2% oak coverage under Sec. 130.39.030 - Definitions. Oak Woodland(s): An oak stand with a greater than 10 percent canopy cover or that may have historically supported greater than 10 percent canopy cover (California Fish and Game Code Section 1361). Following this definition, there are no individual oak trees on the site. There are two native oak trees 24 inches diameter and greater, and no heritage trees. There is one native oak tree 24 inches diameter and greater on the adjacent property to the west that extends into the subject property.

The proposed oak woodland impact will be 90% of the existing oak woodland, retaining 3 trees, 2 trees along the west side and one tree along the street.

Technical Recommendations

It is recommended that all tree care follow specifications written in accordance with ANSI A-300 standards. Pruning of the trees should be performed in the outer portion of the canopy to reduce leverage and end weights and allow the center of the canopies to grow and fill in with foliage. It is also recommended that when root pruning, the smallest size roots as possible be pruned, cuts be performed with handsaws, loppers, or chainsaws appropriate for the size of the root being cut. The roots should be exposed by excavating prior to cutting. Roots should be pruned prior to root removal within the tree protection area to limit the damage and tearing of roots back towards the tree. Root pruning should be overseen by a qualified arborist.

Tree protection for the three trees alongside the proposed structures can be achieved by installing a fence along the property as far from the trunks of the trees to the edge of the construction area before any clearing, grubbing, or construction is started. If any approved work is to be performed in the tree protection fencing, 4 inches of wood chip mulch will be placed over the soil to avoid compaction. The tree protection shall be written on the construction plans so the workers are aware of the tree protection zone.

A landscape plan was not provided at the time of the inspection. If landscaping is included as part of the project, tree planting should follow the specifications included in Appendix A.

General Tree Care and Maintenance

The appendix information is given so that an onsite landscape manager can properly take care of the retained trees, and newly planted trees. Established native oak trees do not like to have the base of the trunk or their roots and the surrounding soil disturbed or tampered with. Applying or having unintentional landscape water on the trunk flare can cause catastrophic and negative affects to most species of native oak trees. Newly planted oak trees do need their root balls watered until established and then may need supplemental watering during extended periods of dry or hot weather. The landscape be designed using drought tolerant plants that will require little to no watering after establishment. Irrigation should be delivered using an on-surface drip type system that does not require trenching around the oak trees to install. The plants should be spaced at least 6 feet away from the trunk of native oak trees, and the drainage from irrigation should be managed so water does not flow to the trunks of the oak trees. Existing trees that are growing in high use areas should be inspected by a qualified arborist for tree risk on a routine basis, the frequency depending on site use and tree condition.

Observations

The site was inspected on August 2, 2021 by ISA Certified Arborist Dave Mercado, #WE-7311A, to inspect the trees and verify the canopy and tag and measure the trees on the property with proposed development. There were 3 trees 24 inches in diameter or greater and no Heritage Trees, 36 inches in diameter and greater, growing on the site.

Each tree was tagged, measured for diameter and canopy radius, assessed for condition, the number of stems present, and notes explaining the tree characteristics affecting condition were recorded. The tree data is shown on the attached 2545 Greenwood Lane Tree List.

The tree condition rating is a combination of vigor, structure, trunk, branches, trunk flare, live tissue, and defects and decay or pests. It is described in % and range term. The rating scale is:

<u>Range</u>	<u>#</u>	<u>Rating</u>	<u>Description</u>
Excellent	81-100		Found to have none to few defects or decay, and high vigor
Good	61-80		Found to have few defects or decay, and above average vigor
Fair	41-60		Found to have mitigatable defects, limited decay, and average vigor
Poor	21-40		Found to have significant defects, decay, and lower vigor
Very poor	120		Found to have significant defects, decay, and low declining vigor
Dead	0		Found to be dead

Diameter at Breast Height (DBH) is the industry standard for measuring trunk diameter. For trees with straight trunks and normal taper, the measurement is taken at 4.5 feet above grade. When a swollen area, flare from branching, multiple stems, or other abnormal growth is present, the diameter at 4.5 feet would not be characteristic of the subject tree. The measurement is taken at the most appropriate location for determining the reasonable trunk diameter, and the height the measurement was taken is listed. The trees found 24 inches or greater were recorded and confirmed if any trees were found to be 36" diameter or greater, a Heritage Tree.

Other testing or examination:

Discussion:

The project site is approximately 0.88 acres and was found to be an oak woodland. The site adjacent to a school and commercial properties. The oak trees are the remnants of an oak woodland, and there adjacent properties with oak trees extending remnants into adjacent properties.

The oak trees on the property were inspected, and the site plan was reviewed to identify those trees that will be impacted by the proposed development. None of the impacted oak trees were considered individual oak trees. All oak woodland canopy area was evaluated for mitigation requirements. There were no Heritage Trees on the site to include in the mitigation calculations.

The El Dorado County Oak Resource Mitigation calculation is based on the area of oak woodland impacted, the percent of oak woodland being impacted, the individual oak trees growing outside of oak woodland being impacted, and Heritage Trees both in oak woodlands and individual trees being impacted. The total property area is approximately 38,333 square feet or 0.88 acres. The total oak woodland on the property is 22,303 square feet or 0.512 acres. The oak woodland is 58.2% of the total site area.

There will be 3 trees retained on the site, with some encroachment for a total of 222 square feet or 0.051 ac. The total oak woodland proposed for removal and impact for the project is 20,386 or 0.468 acres. The total amount of oak woodland impacted by the development is 90%. The Oak Woodland Mitigation Ratio is determined by the amount of existing Oak Woodland canopy being impacted.

The mitigation ratio chart for El Dorado County ORMP is:

Percent of Oak Woodland Impact	Oak Woodland Mitigation Ratio
0-50%	1:1
50.1 – 75%	1.5:1
75.1-100%	2:1

The proposed oak woodland impact of 90% falls into the Oak Woodland Impact range of 75.1-100%. The proposed oak woodland impact requires a 2:1 mitigation ratio.

The proposed 0.468 acres of total impacted oak woodland will require mitigation at the 2:1 mitigation ratio rate, at the cost of \$8,285.00 per acre for a total acreage of 0.936 acres and a total mitigation fee of \$7,754.76.

There were no impacted individual oak trees and no required individual oak tree mitigation. There were no impacted Heritage Trees and no required Heritage Tree mitigation.

The total mitigation fee for the proposed project will be \$7,754.76.

The oak woodland mitigation requirements for the project was calculated based on the following information:

Total area of the project area: 38,333 square feet, or 0.88 acres

Total area of oak woodland: 22,303 square feet, or 0.512 acres

Total percent of existing oak woodland: 58.2%

Total area of total oak woodland to be removed: 20,386 square feet, or 0.468 acres

Total percent of oak woodland to be removed: 91.4%

Oak Woodland Mitigation Ratio: 2:1

Oak woodland area of sick/dying trees exempt from mitigation 0 square feet or 0 acres

Total area of Oak Woodland to be mitigated: 40,772 square feet, or 0.936 acres

Total number and diameter inches of individual oak trees to be removed: 0 trees, 0 diameter inches

Total number and diameter inches of Heritage Trees to be removed: 0 trees, 0 diameter inches

Total area of pre-mitigated oak canopy to be removed: 0 sq. ft.

Total area of oak canopy required to be mitigated: 40,772 square feet, or 0.936 acres

Total Oak Woodland Area Impacted Mitigation: 0.936 acres @ \$8,285 per acre = \$7,754.76

Individual Oak tree Impacted Mitigation: 0 trees, 0 inches, \$153 per inch: \$0

Heritage Tree Impacted Mitigation: 0 trees, 0 inches, \$459 per inch: \$0

Total Amount of Oak Resource Mitigation: \$7,754.76

With the proposed mitigation, the proposed project is in compliance with the Ordinance 5061, Oak Resources Conservation.

The project is in compliance with General Plan Policy 7.4.5.2 by preserving native oaks wherever possible on the site. There are not large expanses of oak woodland or oak corridors in this development, as existing development has left small groves of oak woodland. This report also provides information how trees in the vicinity of the project or construction site will be protected and by following approved preservation methods specified in the County's required mitigation measures.

It has been determined that the proposed project would result in less than significant impacts to oak woodland resources with incorporation of mitigation measures listed below.

For long term maintenance and the changes in site use, some pruning should be performed to larger trees close to the proposed structure, and rear yard areas. The pruning should be performed to remove large dead branches, shorten and reduce end weights, and reduce the risk of branch failure.

Conclusion:

The proposed single-family home project will impact the existing oak woodland. Per the El Dorado County Oak Resources Conservation Ordinance mitigation will be required for 1 of the three potential 3 impacts:

1. Oak woodland is proposed to be impacted. There are 0.461 acres of Oak Woodland proposed to be impacted, and this is 91.4% of the total oak woodland area. The mitigation ratio is 2:1 times the acreage impacted, equaling 0.936 acres of oak woodland mitigation required. The cost of the 0.936 acres at \$8,285 per acre amounts to \$7,754.76 in mitigation fees.
2. There are 0 individual oak trees proposed to be impacted with 0 total inches of diameter. The cost for mitigation is \$153 per inch. The cost of the 0 trees is \$0 in mitigation fees.

3. There are 0 Heritage Trees, trees with a single, or multiple combined, trunk diameter of 36 inches or greater, in fair and better condition, proposed to be impacted. The cost for mitigation is \$459 per inch. The cost of the 0 trees is \$0.

The total mitigation cost of proposed oak impacts is \$7,754.76.

The mitigation proposed will meet the required mitigation based on the El Dorado County ORMP Oak Resources requirements and Ordinance No. 5061.

Please contact Gordon Mann of California Tree and Landscape Consulting, Inc., if there are any questions about this report.

Disclaimer: Gordon Mann, has analyzed the situation, applied the proper method(s) utilized within the profession, and performed a reasonableness test to support the project tree related decisions. I, nor the employees or subcontractors of California Tree and Landscape Consulting, Inc., may be held liable for the misuse or misinterpretation of this report. As the author of this report, I do hereby certify that all the statements of fact in this report are true, complete, and correct to the best of my knowledge and belief, and that they are made in good faith.

Respectfully submitted,

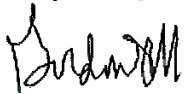

Gordon Mann
ASCA Registered Consulting Arborist #480
ISA Certified Arborist WE- 0151AM
ISA TRAQ Qualified Tree Risk Assessor
California Tree and Landscape Consulting, Inc.
Gordon@caltlc.com
650-740-3461

Appendix A Images
Appendix B Tree Protection
Appendix C Long Term Landscape Maintenance Plan and Specifications
Appendix D Avoiding Damage During Construction
Resume for Gordon Mann

Appendix A Images



Aerial image with trees in approximate locations



Property Outline and Oak Woodland (brown) and proposed retention (green)

August 28, 2021

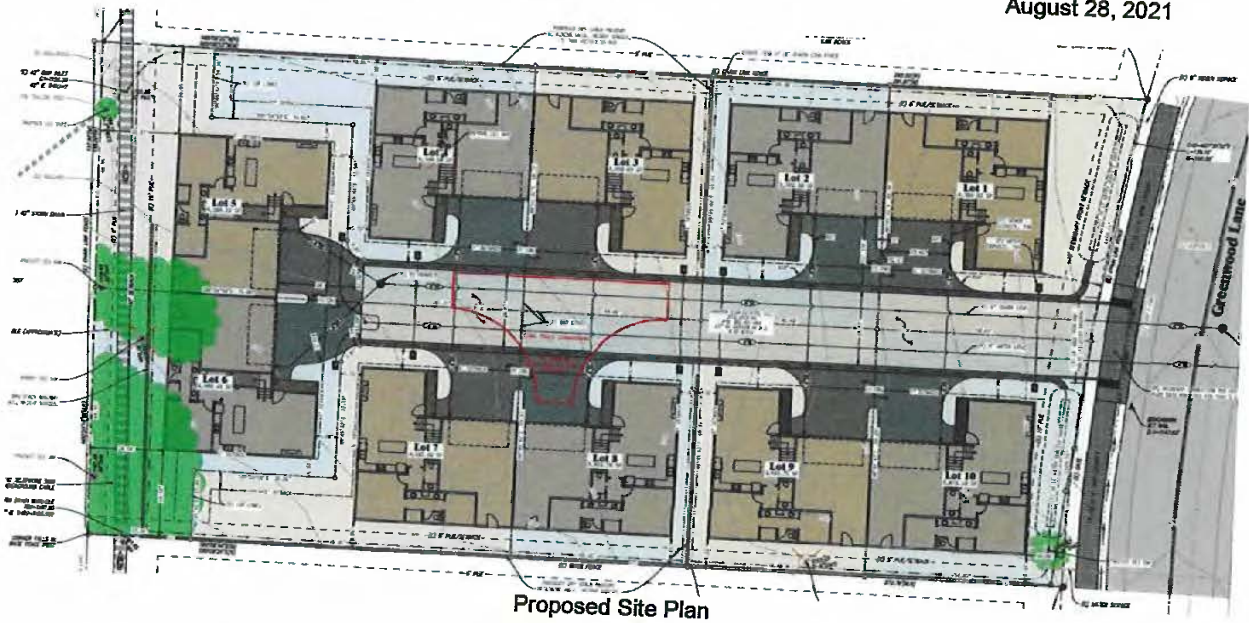

2545 Greenwood Ln
 Tree List

Tree #	Common Name	Latin Name	DBH (in.)	Ht Dia Meas at (ft)	Crown Radius (ft)	Condition	Condition Rating (%)	Observation Comments	Development status
5252	Chinese Tallow Tree	Triadica sebifera	4	4.5				undersized, non-native	retain and protect
5251	Blue Oak	Quercus douglasii	34	3	30	Fair	45	Several old mid branch failures, central top removed, vigor good,	remove
5250	Blue Oak	Quercus douglasii	28	4.5	21	Poor	30	Cavity at 4 feet above grade, poor vigor, understory with bow,	remove
5249	Blue Oak	Quercus douglasii	29	3	36	Fair	50	Offsite, one foot from property line (tpz) Co dom at 5 feet,	retain and protect
5248	Blue Oak	Quercus douglasii	28	4.5	21	Fair	50	Moderate lean with bow, understory, reaction wood with rib on tension side. Vigor good	retain and protect
5247	Blue Oak	Quercus douglasii	21	4.5	27	Fair	45	Slightly thinning central crown, fare good vigor fair	retain and protect
5246	Valley oak	Quercus lobata	7	4.5	9	Fair	45	Absent fare north side, vigor fair	remove
5245	Valley oak	Quercus lobata	7	4.5	18	Poor	30	Inclusion at 12 inches above grade, poor branch angles and poor structure, vigor good	remove
5244	Valley oak	Quercus lobata	16	1	21	Poor	30	Slightly buried fare, Co dom with inclusion at 18 inches above grade, poor structure vigor fair	remove
5243	Valley oak	Quercus lobata	10	2	12	Good	70	Slightly buried fare, Co dom with inclusion at 36 inches above grade,	remove

8 trees on property, 1 tree on adjacent property, 3 trees 24"+, 1 tree undersized non-native; remove 6, retain 2 on site

Tree List, 3 Trees Found to be 24" Diameter and Greater; 5 trees to be removed; 3 trees retained

Appendix B
 Tree Protection

The edge of the tree canopy outside of the construction area shall be fenced off with construction fencing, either temporary orange fence or chain link fence. The fence shall be placed as far from the trees as possible, targeting outside the dripline. If the fence cannot be placed outside of the dripline, the project arborist shall determine if the distance is acceptable or some other soil protection is necessary. A certified arborist must approve the placement of the tree fence. The fence will be marked with weather appropriate signage clearly stating the area as "Protected! Do not enter! Tree preservation zone." Sign(s) will be placed on every face or direction of fence line.

When excavating or trenching adjacent to trees, roots 2 inches and greater encountered in the trench shall be cleanly severed at the trench side closest to the tree, and then excavated, so the roots are not torn back towards the tree. Cut exposed roots ends or exposed roots shall be covered with moist soil or moist burlap and kept moist until the soil is backfilled.

No storage of supplies or materials, parking, or other construction activity shall occur within the fenced area. If a construction activity is required within the construction area, specific specifications and mitigation shall be written to cover the work, and the fencing may be entered during the necessary construction activity, then the fencing shall be replaced after the activity is completed for the day.

The construction protection shall remain in place until the project is completed, including landscape activities. Landscape activities shall have specifications that protect the trees during the landscape activities.

Any bare soil around protected trees should be covered with a 4-inch layer of mulch consisting of ground-up tree parts.

If the protected trees appear to show signs of yellowing leaves, dead leaves, or other abnormal appearance, contact the project arborist for inspection and mitigation.

Appendix C Long Term Landscape Maintenance Plan and Specifications

General

This plan and specifications are intended to promote the optimum landscape growth and lifespan. These trees shall be pruned to remove dead branches, provide clearance, and reduce the risk of branch failure by reducing end weight leverage on branches.

Pruning Small Trees

Branches are to be pruned by either reduction, thinning, or raising cuts to achieve the appropriate clearance over the area. The smallest diameter branches should be removed, working from the branch tips towards the center, removing none to minimal interior foliage inside the final outward branch cut. Trees shall be cleaned to remove dead branches, weakly attached branches, and branches where significant damage has occurred by rubbing, animals, insects, or critical disease. All pruning cuts shall be made in accordance with American National Standards Institute (ANSI) A300 Part 1 Pruning Standards and International Society of Arboriculture (ISA) Best Management Practices for Pruning.

On trees up to six inches in diameter, all dead branches greater than one-half inch diameter shall be removed. All weakly attached branches and potential co-dominant branches shall either be reduced by at least 20% or be removed, as most appropriate for the long term structure of the tree. The weakest or most damaged branch of a pair or group of rubbing branches shall be shortened to avoid rubbing, or removed. All temporary branches along the trunk should be retained and shortened to obtain necessary clearance. When either temporary branches exceed one-inch diameter, or the trunk forms mature bark, the temporary branches should be removed.

Depending on the location and site needs, clearance should be performed by pruning the smallest branches inward from the branch tips until the permanent branches are in place. Clearance minimums should be set, for example: 7.5' over sidewalks, 10 feet over parking spaces, and 14.5 feet over truck traffic streets. Clearance pruning shall be carefully performed until the permanent branches are identified. Up to 25% of the total foliage on any tree should be the maximum removed during any planned pruning cycle. Follow-up pruning for structure or clearance on young trees can be performed at any time if pruning small amounts of foliage (up to 10%) and retaining the central leader and branch size relationships.

Pruning Large Trees

Branches are to be pruned by either reduction, thinning, or raising cuts to achieve the appropriate clearance over the area. The smallest diameter branches should be removed, working from the branch tips towards the center, removing none to minimal interior foliage inside the final outward branch cut. Trees shall be cleaned to remove dead branches, weakly attached branches, and branches where significant damage has occurred by rubbing, animals, insects, or critical disease. All pruning cuts shall be made in accordance with American National Standards Institute (ANSI) A300 Part 1 Pruning Standards and International Society of Arboriculture (ISA) Best Management Practices for Pruning.

The trees to be pruned are the trees retained on the site. The objective is to remove dead branches, obtain necessary clearance, and reduce the risk of branch failure. The system is Natural. Dead branches can be removed anywhere in the crown. The location of live branches is in the outer third of the crown. The pruning cuts are reduction cuts and branch removal cuts. The smallest diameter branches are to be pruned to accomplish the objective. A largest diameter branch to be removed shall be stated for each tree.

Appendix D

Avoiding Tree Damage During Construction

Edited from the **ISA**'s tree protection guidelines

As cities and suburbs expand, wooded lands are being developed into commercial and residential sites. Homes are constructed in the midst of trees to take advantage of the aesthetic and environmental value of the wooded lots. Wooded properties can be worth as much as 20 percent more than those without trees, and people value the opportunity to live among trees.

Unfortunately, the processes involved with construction can be deadly to nearby trees. Unless the damage is extreme, the trees may not die immediately but could decline over several years. With this delay in symptom development, you may not associate the loss of the tree with the construction.

It is possible to preserve trees on building sites if the right measures are taken. The most important step is to hire a professional arborist during the planning stage. An arborist can help you decide which trees can be saved and can work with the builder to protect the trees throughout each construction phase.

How Trees Are Damaged During Construction

Physical Injury to Trunk and Crown. Construction equipment can injure the aboveground portion of a tree by breaking branches, tearing the bark, and wounding the trunk. These injuries are permanent and, if extensive, can be fatal.

Cutting of Roots. The digging and trenching that are necessary to construct a house and install underground utilities will likely sever a portion of the roots of many trees in the area. It is easy to appreciate the potential for damage if you understand where roots grow. The roots of a tree are found mostly in the upper 6 to 24 inches of the soil. In a mature tree, the roots extend far from the trunk. In fact, roots typically are found growing a distance of one to three times the height of the tree. The amount of damage a tree can suffer from root loss depends, in part, on how close to the tree the cut is made. Severing one major root can cause the loss of 5 to 20 percent of the root system.

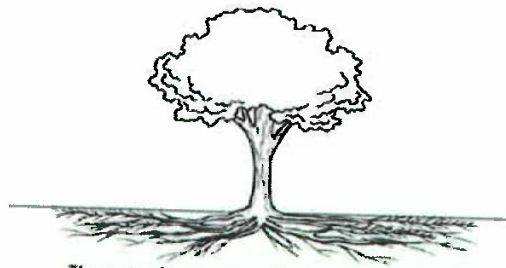

The roots of a tree extend far from the trunk and are found mostly in the upper 6 to 12 inches of soil.

Another problem that may result from root loss caused by digging and trenching is that the potential for the trees to fall over is increased. The roots play a critical role in anchoring a tree. If the major support roots are cut on one side of a tree, the tree may fall or blow over.

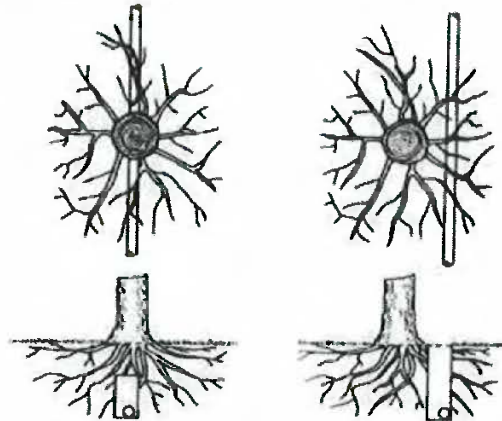

Less damage is done to tree roots if utilities are tunneled under a tree (right, top and bottom) rather than across the roots (left, top and bottom).

Less damage is done to tree roots if utilities are tunneled under a tree rather than across the roots.

Soil Compaction. An ideal soil for root growth and development is about 50 percent pore space. These pores—the spaces between soil particles—are filled with water and air. The heavy equipment used in construction compacts the soil and can dramatically reduce the amount of pore space. This compaction not only inhibits root growth and penetration but also decreases oxygen in the soil that is essential to the growth and function of the roots, and water infiltration.

Smothering Roots by Adding Soil. Most people are surprised to learn that 90 percent of the fine roots that absorb water and minerals are in the upper 6 to 12 inches of soil. Roots require space, air, and water. Roots grow best where these requirements are met, which is usually near the soil surface. Piling soil over the root system or increasing the grade smothers the roots. It takes only a few inches of added soil to kill a sensitive mature tree.

Exposure to the Elements. Trees in a forest grow as a community, protecting each other from the elements. The trees grow tall, with long, straight trunks and high canopies. Removing neighboring trees or opening the shared canopies of trees during construction exposes the remaining trees to sunlight and wind. The higher levels of sunlight may cause sunscald on the trunks and branches. Also, the remaining trees are more prone to breaking from wind or ice loading.

Getting Advice

Hire a professional arborist in the early planning stage. Many of the trees on your property may be saved if the proper steps are taken. Allow the arborist to meet with you and your building contractor. Your arborist can assess the trees on your property, determine which are healthy and structurally sound, and suggest measures to preserve and protect them.

One of the first decisions is determining which trees are to be preserved and which should be removed. You must consider the species, size, maturity, location, and condition of each tree. The largest, most mature trees are not always the best choices to preserve. Younger, more vigorous trees usually can survive and adapt to the stresses of construction better. Try to maintain diversity of

species and ages. Your arborist can advise you about which trees are more sensitive to compaction, grade changes, and root damage.

Planning

Your arborist and builder should work together in planning the construction. The builder may need to be educated regarding the value of the trees on your property and the importance of saving them. Few builders are aware of the way trees' roots grow and what must be done to protect them.

Sometimes small changes in the placement or design of your house can make a great difference in whether a critical tree will survive. An alternative plan may be more friendly to the root system. For example, bridging over the roots may substitute for a conventional walkway. Because trenching near a tree for utility installation can be damaging, tunneling under the root system may be a good option.

Erecting Barriers

Because our ability to repair construction damage to trees is limited, it is vital that trees be protected from injury. The single most important action you can take is to set up construction fences around all of the trees that are to remain. The fences should be placed as far out from the trunks of the trees as possible. As a general guideline, allow 1 foot of space from the trunk for each inch of trunk diameter. The intent is not merely to protect the aboveground portions of the trees but also the root systems. Remember that the root systems extend much farther than the drip lines of the trees.

Instruct construction personnel to keep the fenced area clear of building materials, waste, excess soil, and equipment. No digging, trenching, or other soil disturbance such as driving vehicles and equipment over the soil should be allowed in the fenced area.

Protective fences should be erected as far out from the trunks as possible in order to protect the root system prior to the commencement of any site work, including grading, demolition, and grubbing.

Limiting Access

If at all possible, it is best to allow only one access route on and off the property. All contractors must be instructed where they are permitted to drive and park their vehicles. The construction access drive should be the route for utility wires; underground water, sewer, or storm drain lines; roadways; or the driveway.



Protective fences should be erected as far out from the trunks as possible in order to protect the root systems.

Specify storage areas for equipment, soil, and construction materials. Limit areas for burning (if permitted), cement wash-out pits, and construction work zones. These areas should be away from protected trees.

Specifications

Specifications are to be put in writing. All of the measures intended to protect your trees must be written into the construction specifications. The written specifications should detail exactly what can and cannot be done to and around the trees. Each subcontractor must be made aware of the barriers, limitations, and specified work zones. It is a good idea to post signs as a reminder.

Fines and penalties for violations should be built into the specifications. Not too surprisingly, subcontractors are much more likely to adhere to the tree preservation clauses if their profit is at stake. The severity of the fines should be proportional to the potential damage to the trees and should increase for multiple infractions.

Maintaining Good Communications

It is important to work together as a team. You may share clear objectives with your arborist and your builder, but one subcontractor can destroy your prudent efforts. Construction damage to trees is often irreversible.

Visit the site at least once a day if possible. Your vigilance will pay off as workers learn to take your wishes seriously. Take photos at every stage of construction. If any infraction of the specifications does occur, it will be important to prove liability.

Final Stages

It is not unusual to go to great lengths to preserve trees during construction, only to have them injured during landscaping. Installing irrigation systems and roto-tilling planting beds are two ways the root systems of trees can be damaged. Remember also that small increases in grade (as little as 2 to 6 inches) that place additional soil over the roots can be devastating to your trees. ANSI A300 Standards Part 5 states that tree protection shall be in place for the landscape phase of the site development. Landscape tree protection may be different than other construction process tree protection, and a conference with the landscape contractor should be held prior to the commencement of the landscape work. Careful planning and communicating with landscape designers and contractors is just as important as avoiding tree damage during construction.

Post-Construction Tree Maintenance

Your trees may require several years to adjust to the injury and environmental changes that occur during construction. The better construction impacts are avoided, the less construction stress the trees will experience. Stressed trees are more prone to health problems such as disease and insect infestations. Talk to your arborist about continued maintenance for your trees. Continue to monitor your trees, and have them periodically evaluated for declining health or safety hazards.

Despite the best intentions and most stringent tree preservation measures, your trees still might be injured from the construction process. Your arborist can suggest remedial treatments to help reduce stress and improve the growing conditions around your trees. In addition, the International Society of

2545 Greenwood Lane, Cameron Park, CA
Arborist Report for Oak Resources Management Plan

August 28, 2021

Arboriculture offers a companion to this brochure titled "Treatment of Trees Damaged by Construction".



California Tree and Landscape Consulting, Inc.

GORDON MANN

EDUCATION AND QUALIFICATIONS

- 1977 Bachelor of Science, Forestry, University of Illinois, Champaign.
- 1982 - 1985 Horticulture Courses, College of San Mateo, San Mateo.
- 1984 Certified as an Arborist, WE-0151A, by the International Society of Arboriculture (ISA).
- 2004 Certified as a Municipal Specialist, WE-0151AM, by the ISA.
- 2011 Registered Consulting Arborist, #480, by the American Society of Consulting Arborists (ASCA).
- 2003 Graduate of the ASCA Consulting Academy.
- 2006 Certified as an Urban Forester, #127, by the California Urban Forests Council (CaUFC).
- 2011 TRACE Tree Risk Assessment Certified, continued as an ISA Qualified Tree Risk Assessor (T.R.A.Q.).



PROFESSIONAL EXPERIENCE

- 2016 – Present **CALIFORNIA TREE AND LANDSCAPE CONSULTING, INC (CalTLC). President and Consulting Arborist.**
Auburn. Mr. Mann provides consultation to private and public clients in health and structure analysis, inventories, management planning for the care of trees, tree appraisal, risk assessment and management, and urban forest management plans.
- 1986 - Present **MANN MADE RESOURCES. Owner and Consulting Arborist. Auburn.**
Mr. Mann provides consultation in municipal tree and risk management, public administration, and developing and marketing tree conservation products.
- 2015 – 2017 **CITY OF RANCHO CORDOVA, CA. Contract City Arborist.**
Mr. Mann serves as the City's first arborist, developing the tree planting and tree maintenance programs, performing tree inspections, updating ordinances, providing public education, and creating a management plan.
- 1984 – 2007 **CITY OF REDWOOD CITY, CA. City Arborist, Arborist, and Public Works Superintendent.**
Mr. Mann developed the Tree Preservation and Sidewalk Repair Program, supervised and managed the tree maintenance program, performed inspections and administered the Tree Preservation Ordinance. Additionally, he oversaw the following Public Works programs: Streets, Sidewalk, Traffic Signals and Streetlights, Parking Meters, Signs and Markings, and Trees.
- 1982 – 1984 **CITY OF SAN MATEO, CA. Tree Maintenance Supervisor.**
For the City of San Mateo, Mr. Mann provided supervision and management of the tree maintenance program, and inspection and administration of the Heritage Tree Ordinance.
- 1977 – 1982 **VILLAGE OF BROOKFIELD, IL. Village Forester.**
Mr. Mann provided inspection of tree contractors, tree inspections, managed the response to Dutch Elm Disease. He developed an in-house urban forestry program with leadworker, supervision, and management duties to complement the contract program.
- 1979 - Present **INTERNATIONAL SOCIETY OF ARBORICULTURE. Member.**
 - Board of Directors (2015 - Present)

- True Professional of Arboriculture Award (2011); In recognition of material and substantial contribution to the progress of arboriculture and having given unselfishly to support arboriculture.
- 1982 - Present WESTERN CHAPTER ISA (WCISA). Member.
 - Chairman of the Student Committee (2014 - 2017)
 - Member of the Certification Committee (2007 - Present)
 - Chairman of the Municipal Committee (2009 - 2014) • Award of Merit (2016) In recognition of outstanding meritorious service in advancing the principles, ideals and practices of arboriculture.
 - Annual Conference Chair (2012)
 - Certification Proctor (2010 - Present)
 - President (1992 - 1993)
 - Award of Achievement and President's Award (1990)
- 1985 - Present CALIFORNIA URBAN FORESTS COUNCIL (CaUFC). Member; Board Member (2010 - Present)
- 1985 - Present SOCIETY OF MUNICIPAL ARBORISTS (SMA). Member. e Legacy Project of the Year (2015) o In recognition of outstanding meritorious service in advancing the principles, ideals and practices of arboriculture.
 - Board Member (2005 - 2007)
- 2001 - Present AMERICAN SOCIETY OF CONSULTING ARBORISTS.
Member. e Board of Directors (2006 - 2013)
 - President (2012)
- 2001 - Present CAL FIRE. Advisory Position.
 - Chairman of the California Urban Forestry Advisory Committee (2014 - 2017)
- 2007 - Present AMERICAN NATIONAL STANDARDS INSTITUTE (ANSI): A300 TREE MAINTENANCE STANDARDS
COMMITTEE. SMA Representative and Alternate.
 - Alternative Representative for SMA (2004 - 2007; 2012 - Present)
 - Representative for SMA (2007 - 2012)
- 2007 - Present SACRAMENTO TREE FOUNDATION. Member and Employee.
 - Co-chair/member of the Technical Advisory Committee (2012 - Present)
 - Urban Forest Services Director (2007 - 2009) e Facilitator of the Regional Ordinance Committee (2007 - 2009)
 - 1988 - 1994 TREE CLIMBING COMPETITION.
 - Chairman for Northern California (1988 - 1992)
 - Chairperson for International (1991 - 1994)

PUBLICATIONS AND LECTURES

Mr. Mann has authored numerous articles in newsletters and magazines such as Western Arborist, Arborist News, City Trees, Tree Care Industry Association, Utility Arborists Association, CityTrees, and Arborists Online, covering a range of topics on Urban Forestry, Tree Care, and Tree Management. He has developed and led the training for several programs with the California Arborist Association. Additionally, Mr. Mann regularly presents at numerous professional association meetings on urban tree management topics.

Assumptions and Limiting Conditions

1. Consultant assumes that any legal description provided to Consultant is correct and that title to property is good and marketable. Consultant assumes no responsibility for legal matters. Consultant assumes all property appraised or evaluated is free and clear, and is under responsible ownership and competent management.
2. Consultant assumes that the property and its use do not violate applicable codes, ordinances, statutes or regulations.
3. Although Consultant has taken care to obtain all information from reliable sources and to verify the data insofar as possible, Consultant does not guarantee and is not responsible for the accuracy of information provided by others.
4. Client may not require Consultant to testify or attend court by reason of any report unless mutually satisfactory contractual arrangements are made, including payment of an additional fee for such Services as described in the Consulting Arborist Agreement.
5. Unless otherwise required by law, possession of this report does not imply right of publication or use for any purpose by any person other than the person to whom it is addressed, without the prior express written consent of the Consultant.
6. Unless otherwise required by law, no part of this report shall be conveyed by any person, including the Client, the public through advertising, public relations, news, sales or other media without the Consultant's prior express written consent.
7. This report and any values expressed herein represent the opinion of the Consultant, and the Consultant's fee is in no way contingent upon the reporting of a specific value, a stipulated result, the occurrence of a subsequent event or upon any finding to be reported.
8. Sketches, drawings and photographs in this report, being intended as visual aids, are not necessarily to scale and should not be construed as engineering or architectural reports or surveys. The reproduction of any information generated by architects, engineers or other consultants and any sketches, drawings or photographs is for the express purpose of coordination and ease of reference only. Inclusion of such information on any drawings or other documents does not constitute a representation by Consultant as to the sufficiency or accuracy of the information.
9. Unless otherwise agreed, (1) information contained in this report covers only the items examined and reflects the condition of those items at the time of inspection; and (2) the inspection is limited to visual examination of accessible items without dissection, excavation, probing or coring. Consultant makes no warranty or guarantee, express or implied that the problems or deficiencies of the plans or property in question may not arise in the future.
10. Loss or alteration of any part of this Agreement invalidates the entire report.

Certificate of Performance

I, Gordon Mann, certify that:

The trees were inspected by an ISA Certified Arborist. I have personally reviewed the trees and site referred to in this report and have stated my findings accurately. The extent of the inspection is stated in the attached report under Assignment;

I have no current or prospective interest in the vegetation, or the property that is the subject of this report and have no personal interest or bias with respect to the parties involved;

The analysis, opinions and conclusions stated herein are my own and are based on current scientific procedures and facts;

My analysis, opinions, and conclusions were developed, and this report has been prepared according to commonly accepted arboricultural practices;

No one provided significant professional assistance to me, except as indicated within the report;

My compensation is not contingent upon the reporting of a predetermined conclusion that favors the cause of the client, or any other party, nor upon the results of the assignment, the attainment of stipulated results, or the occurrence of any subsequent events.

I further certify that I am a member in good standing of the International Society of Arboriculture (ISA) and an ISA Certified Arborist and Municipal Specialist. I am also a Registered Consulting Arborist member in good standing of the American Society of Consulting Arborists. I have been involved in the practice of arboriculture and the care and study of trees for over 43 years.

Signed:

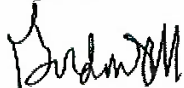

Gordon Mann

Date: August 28, 2021

BIOLOGICAL RESOURCES EVALUATION MEMORANDUM FOR THE GREENWOOD ESTATES PROJECT, CAMERON PARK, EL DORADO COUNTY, CA

PREPARED BY: FEC, INC.

Introduction

FEC, Inc. (FEC) has prepared this Biological Resources Evaluation (BRE) for the Greenwood Estates project (proposed project) located in the community of Cameron Park in unincorporated El Dorado County, CA. The purpose of this BRE is to document baseline biological resources in the project site and to assess the potential for sensitive biological resources including special-status species, sensitive natural communities, or other protected biological resources such as wetlands or other waters of the U.S. or State or protected trees to occur in the project site and/or be impacted by the proposed project. This BRE also proposes mitigation to avoid or reduce any such impacts. This report is intended to support project planning and entitlements including California Environmental Quality Act (CEQA) documentation.

Project Location and Description

The site of the proposed project is a 0.88-acre parcel located at 2545 Greenwood Lane (APN 082-411-004) just north of Highway 50 in the community of Cameron Park (Attachment A; Figure 1). The project site is located at Township 09N, Range 09E, Section 5 of the "Clarksville, CA" U.S. Geological Survey 7.5 minute topographic quadrangle (quad) (Attachment A; Figure 2) with the center of the site located at latitude 38°39'31.44"N and longitude 121°00'09.51" W, North American Datum (NAD) 83.

The proposed project consists of subdividing the parcel and developing ten (10) single-family residential lots on the parcel.

FILE COPY

Methods:

Biological Studies

Biological studies conducted in support of this report included a special-status species evaluation and a biological reconnaissance survey. The special-status species evaluation was conducted in order to assemble a list of regionally-occurring special-status species with the potential to be impacted by proposed projects in the region. The biological reconnaissance survey was then conducted to determine regionally-occurring special-status species with the potential to occur on the project site and/or be impacted by the proposed project.

Special-Status Species Evaluation

The special-status species evaluation included obtaining lists of special-status species with the potential to occur in the project region from the following sources: the U.S. Fish and Wildlife Service (USFWS) online list of federally-listed special-status species with the potential to occur in, or be affected by projects in the project site, the list of reported occurrences of special-status species in the California Natural Diversity Database (CNDDDB) for the "Clarksville, California" and "Shingle Springs, California" USGS quads, and the list of reported occurrences of special-status plant species in the California Native Plant Society (CNPS) database for the "Clarksville, California" and "Shingle Springs, California" USGS quads. Results of these queries are included in Attachment B. Special status species with the potential to occur in the project vicinity were compared with the habitats on site and other factor such as soil types on the project site and elevational and geographic ranges of the special-status species to determine if a species has the potential to occur within the project site.

Biological Reconnaissance Survey

An FEC biologist conducted a biological reconnaissance survey on August 26, 2021 to characterize and map the biological habitats within the proposed project site. The biological reconnaissance survey area consisted of the entire 0.88-acre parcel (APN: 082-411-004). The entire site was walked and searched for the presence of special-status species or sensitive natural communities, including the potential presence of wetlands or other waters of the U.S. and State. Plant and animal species observed on the project site that were identifiable at the time of the biological reconnaissance were documented. Attachment C is a list of species observed on the site during the survey.

Regulatory Background

Special-Status Species and Nesting Birds

For the purpose of this technical memorandum, special-status species are defined as: species listed under the Federal Endangered Species Act of 1973 (hereafter, "FESA," 16 USC Section 1531 et seq.) as Threatened or Endangered, as well as Candidate species and species proposed

for listing; species listed under the California Endangered Species Act (CESA) of 1970 (CDFG Code Section 2050 et seq., and CCR Title 14, Subsection 670.2, 670.51) as Threatened or Endangered; species of special concern or watch list species as designated by the CDFG; species that are not currently protected by statute or regulation, but would be considered rare, threatened, or endangered under these criteria, or by the scientific community [CEQA Guidelines subsection 15380(b) and (d)]; and plant species considered rare according to the California Native Plant Society (CNPS); specifically plants on Lists 1A, 1B, 2, and 3 are considered special-status species under CEQA. While not technically considered special-status species, migratory bird species listed on the federal list (50 CFR Section 10.13) are protected under the Migratory Bird Treaty Act of 1918 (16 USC Subsection 703-712). Migratory bird species and their nests and eggs are protected from injury or death. California Fish and Game Code Subsections 3503, 3503.5, and 3800 also prohibit the possession, incidental take, or needless destruction of birds, their nests, and eggs. Therefore, potential impacts to migratory birds and nesting birds are discussed.

Jurisdictional Waters

Any person, firm, or agency planning to alter or work in “waters of the U.S.,” including the discharge of dredged or fill material, must first obtain authorization from the U.S. Army Corps of Engineers (USACE) under Section 404 of the Clean Water Act (CWA; 33 USC 1344) or Section 10 of the Rivers and Harbors Act. The Rivers and Harbors Act prohibits the obstruction or alteration of navigable waters of the U.S. without a permit from USACE (33 USC 403). Within non-tidal waters, in the absence of adjacent wetlands, the extent of USACE jurisdiction extends to the ordinary high water mark (OHWM), which is defined as:

“A line on the shore established by fluctuations of water and indicated by a clear, natural line impressed on the bank, shelving, changes in soil character, destruction of terrestrial vegetation, or the presence of litter and debris.”

Wetlands are defined in 33 CFR Part 328 as:

“Areas that are inundated or saturated by surface or ground water at a frequency and duration to support, and that under normal circumstances do support, a prevalence of vegetation typically adapted for life in saturated soil conditions.”

Any action requiring a CWA Section 404 permit, or a Rivers and Harbors Act Section 10 permit, must also obtain a CWA Section 401 Water Quality Certification for impacts to “Waters of the State”, which are defined as “any surface water or groundwater, including saline waters, within the boundaries of the state.” Impacts to “Waters of the State” may also require a Lake or Streambed Alteration Agreement under Section 1600 et seq. of the California Fish and Game Code. A Lake or Streambed Alteration Agreement is required if a proposed project will

“substantially divert or obstruct the natural flow or substantially change the bed, channel, or bank of streambeds.

Protected Trees

El Dorado County General Plan Amendment approved in October 2017 and the County’s Oak Resources Management Plan and the Oak Resources Conservation Ordinance protect individual native oak trees and oak woodland canopy. Project proponents are required to inventory all native oak trees in the woodland area 24 inches in diameter and greater, identify all Heritage Trees 36 inches in diameter and greater, and any individual oak trees 6 inches in diameter and greater located outside of the woodland area. A permit is required from El Dorado County for non-exempt impacts to oak resources including oak canopy, individual native oaks and Heritage trees and mitigation is required to replace lost oak resources.

Determination of Potential Impacts

The following thresholds of impact significance are based on California Environmental Quality Act (CEQA) guidelines. Based on the CEQA guidelines, the Project would have a significant impact on biological resources if it would result in any of the following:

- Have a substantial adverse effect, either directly or through habitat modifications, on any species identified as a candidate, sensitive, or special status species in local or regional plans, policies, or regulations, or by the CDFW or the USFWS;
- Have a substantial adverse effect on any riparian habitat or other sensitive natural community identified in local or regional plans, policies, regulations, or by the CDFW or the USFWS;
- Have a substantial adverse effect on federally protected wetlands as defined by Section 404 of the Clean Water Act (including, but not limited to, marsh, vernal pool, coastal, etc.) through direct removal, filling, hydrological interruption, or other means;
- Interfere substantially with the movement of any native resident or migratory fish or wildlife species or with established native resident or migratory wildlife corridors or impede the use of native wildlife nursery sites;
- Conflict with any local policies or ordinances protecting biological resources, such as a tree preservation policy or ordinance; or,
- Conflict with the provisions of an adopted Habitat Conservation Plan, Natural Community Conservation Plan, or other approved local, regional, or state habitat conservation plan.

Results: Environmental Setting

Existing Conditions

The project site is located within a commercial/light industrial area in the south side of Cameron Park just north of Highway 50. The surrounding area is a mix of retail, light industrial, commercial and residential housing. The project site is an empty lot with no structures and no apparent uses. The project site had been mowed prior to the biological reconnaissance survey, likely in late spring or early summer. Figure 3 in Attachment A is an aerial map of the project site.

Topography and Soils

The project site is primarily flat and gently sloping from east to west with an elevation of approximately 1,150 to 1,165 feet amsl.

Two soils types are mapped on the project site, including Auburn silt loam, 2 to 30 percent slopes, and Sobrante silt loam, 3 to 15 percent slopes (Attachment A; Figure 4). Auburn silt loam is the primary soil type on the site and encompasses the majority of the site, with Sobrante silt loam occurring in a small strip along the southeast corner of the site (NRCS 2021). These soil types are discussed below.

Auburn silt loam, 2 to 30 percent slopes, occurs on hills between 120 to 3,000 feet above mean sea level and consists of residuum weathered from basic igneous rock and/or basic residuum weathered from metamorphic rock. A typical profile is silt loam from 0 to 14 inches and unweathered bedrock from 14 to 18 inches. Lithic bedrock occurs at a depth of 14 to 18 inches. This soil series is well drained with a frequency of flooding of "none" and ponding of "none" and a depth to water table of more than 80 inches (NRCS 2021).

Sobrante silt loam, 3 to 15 percent slopes, occurs on hillslopes between 120 and 3,500 feet above mean sea level and consists of residuum weathered from metamorphic rock. A typical profile is silt loam from 0 to 11 inches, clay loam from 11 to 24 inches, weathered bedrock from 24 to 30 inches, and unweathered bedrock from 30 to 34 inches. This soil series is well drained with a frequency of flooding of "none" and ponding of "none" and a depth to water table of more than 80 inches, with paralithic bedrock located at a depth of 24 to 30 inches and lithic bedrock at a depth of 30 to 34 inches (NRCS 2021).

Habitat Types in the Project Area

The project site contains one habitat type: non-native annual grassland (Attachment A; Figure 5). The site is vegetated primarily with non-native grasses and forbs typical of disturbed sites within largely developed areas. The dominant species within the non-native annual grassland are non-native grasses including wild oat (*Avena fatua*), soft chess (*Bromus hordeaceus*), barley

(*Hordeum marinum*), medusa head (*Elymus caput-medusae*), ripgut brome (*Bromus diandrus*), fescue (*Vulpia microstachys*), and silver European hairgrass (*Aira caryophyllea*). Common forbs included doveweed (*Croton setiger*), rose clover (*Trifolium hirtum*), prickly lettuce (*Lactuca serriola*), and tarweed (*Holocarpha virgata*). Some large blue oaks (*Quercus douglassii*) occur along the western side of the parcel and there are some scattered small coyote bush (*Baccharis pilularis*). Otherwise, the site is primarily vegetated with ruderal herbaceous species. Representative photos of the site are included as Figure 6 in Attachment A.

General Wildlife Use of the Site

The project site is located within an urban area and is surrounded by development. Wildlife use of the site would be expected to be limited to common species adapted to disturbed areas. No wildlife was observed on the project site during the biological reconnaissance; however, there were several ground squirrel (*Otospermophilus beecheyi*) burrows in the project site.

Results: Special-Status Species and Other Protected Biological Resources

Special-Status Species

Based on the results of the background review and database searches, there are a total of 11 plant species and 21 animal species meeting the criteria for a special-status species as defined in this report that are documented within the "Clarksville, CA" and "Shingle Springs, CA" USGS quads. All 11 special-status plants and 21 special-status animals were evaluated for the potential to occur within the project site and/or be impacted by the proposed project. The evaluation was based on factors such as habitat requirements, elevational and geographic ranges, and soil requirements. This evaluation is documented in Attachment D. Species that were determined to have no potential to occur in the project site or be impacted by the proposed project are not discussed further in this document.

Special-Status Plants

No special-status plant species were observed in the project site during the biological reconnaissance survey. Based on the evaluation of the potential for special-status plant species to occur in the project site that is described above and documented in Attachment D, there are no special-status plant species with the potential to occur in the project site. Regionally-occurring special-status plant species primarily occur on serpentinite, gabbroic, or volcanic soils within chaparral, oak woodland, or cismontane forest habitats. The project site is comprised of non-native grassland and is primarily vegetated with non-native grasses and forbs typical of disturbed areas. The project site does not provide suitable soils or habitat for special-status

plant species. No impacts to special-status plant species would be expected to occur as a result of project implementation.

Special-Status Animals

No special-status animal species were observed in the project site during the biological reconnaissance survey. Based on the evaluation of the potential for special-status animal species to occur in the project site that is described above and documented in Attachment D, there are no special-status animal species with the potential to occur in the project site. The majority of the regionally-occurring special-status animal species require aquatic habitats such as vernal pools, seasonal wetlands, ponds, marshes, and riverine habitats. The remaining species occur in large tracts of undeveloped lands such as open grasslands or forested habitats. There are no aquatic habitats in or adjacent to the project site and the site is small and surrounded by development. No impacts to special-status animal species would be expected to occur as a result of project implementation.

Raptors, Migratory Birds, and Other Nesting Birds

No bird nests were observed in the project site during the biological reconnaissance survey. However, nesting habitat for common raptors, migratory birds and other nesting birds is present in the oak trees in and adjacent to the project site. Common raptor species such as red-tailed hawk (*Buteo jamaicensis*) and red-shouldered hawk (*Buteo lineatus*) could nest in oak trees in or adjacent to the site. Common bird species could also nest in herbaceous vegetation or on the ground such as mourning dove (*Zenaidura macroura*), killdeer (*Charadrius vociferous*), or a variety of other songbirds. If project activities were to commence during the typical bird nesting season (February 1 to August 31), project activities in the vicinity of bird nests could lead to abandonment of eggs or young or forced fledging, which would be a violation of Fish and Game Code and a significant impact.

Riparian Habitats or Other Sensitive Natural Communities

Riparian habitats are often considered sensitive natural communities and are also regulated under Section 1600 of the Fish and Game Code. Plant communities are considered sensitive biological resources if they have limited distributions, have high wildlife value, include sensitive species, and/or are particularly susceptible to disturbance. CDFW ranks sensitive communities as "threatened" or "very threatened" and keeps records of their occurrences in CNDDDB. CNDDDB vegetation alliances are ranked 1 through 5, with those alliances ranked globally (G) or statewide (S) as 1 through 3 considered sensitive. Some alliances with the rank of 4 and 5 have also been included in the 2020 sensitive natural communities list under CDFW's revised ranking methodology (CDFW 2021).

There are no riparian habitats or sensitive natural communities on the site and there are no reported occurrences of sensitive natural communities in the CNDDDB for the "Clarksville, CA" or

Biological Resources Evaluation
Greenwood Estates

“Shingle Springs, CA” USGS quads. The only habitat type present in the project site is non-native annual grassland, which is not considered a sensitive natural community. Therefore, no impacts to sensitive natural communities would occur as a result of the proposed project.

Wildlife Movement Corridors

Wildlife movement corridors, or habitat linkages, are connections between patches of habitat, generally native vegetation, which join two or more larger areas of similar wildlife habitat and allows for physical and genetic exchange between animal populations that could otherwise be isolated. Habitat linkages are typically contiguous strips of natural areas such as riparian corridors, oak woodlands, or drainages. Wildlife movement corridors are critical for the maintenance of ecological processes including facilitating the movement of animals and the continuation of viable populations. Movement corridors may serve to provide a more local linkage such as between foraging and denning areas, or they may be regional in nature providing larger scale migration corridors such as between wintering and summering habitat. Habitat linkages may also serve to allow animals to periodically move away from an area and then subsequently return. Other corridors may be important as dispersal corridors for young animals. A group of habitat linkages in an area can form a wildlife corridor network.

The project site is not included in any wildlife movement or connectivity corridors mapped by the California Essential Habitat Connectivity project (CDFW 2021) and does not provide any unique movement or dispersal habitat relative to surrounding lands. The project site is also not located within a Natural Landscape Block (defined as relatively natural habitat blocks that support native biodiversity). Therefore, the project will not impact any wildlife movement corridors.

Jurisdictional Waters

The U.S. Fish and Wildlife Service’s National Wetlands Inventory (NWI) online database was reviewed to determine if there are any wetlands or other waters of the U.S. mapped by the USFWS in the Study Area (USFWS 2021b). A review of Google Earth historic aerial imagery was also conducted to search for any evidence of wetlands on the site.

During the biological reconnaissance survey, the project site was searched for areas that could potentially qualify as wetlands by containing a predominance of hydrophytic vegetation, hydric soils, and wetland hydrology according to the *Corps of Engineers Wetlands Delineation Manual* (USACE 1987) and the *Regional Supplement to the Corps of Engineers Wetland Delineation Manual: Arid West Region (Version 2.0)* (USACE 2008). No potential wetlands or other aquatic resources were observed on the site during the biological reconnaissance survey and no evidence of potential wetlands or other aquatic resources was identified in the project site

during a search of the NWI database or the review of historic aerial imagery. Therefore, no impacts to wetlands or other aquatic resources would occur as a result of the proposed project.

Protected Trees

An arborist report for oak woodland resources was prepared in compliance with the El Dorado County General Plan Amendment approved in October 2017 and the County's Oak Resources Management Plan and the Oak Resources Conservation Ordinance. The purpose of the arborist report was to determine the oak woodland area on the site, identify all native oak trees in the woodland area 24 inches in diameter and greater, identify all Heritage Trees 36 inches in diameter and greater, and any individual oak trees 6 inches in diameter and greater located outside of the woodland area designated for removal (CalTLC 2021).

The site contains a total of eight trees including four blue oak (*Quercus douglasii*) and four valley oak (*Quercus lobata*). In addition, there is one Blue Oak on the adjacent property to the west extending into the site. The oaks on the site were considered to be a remnant oak woodland with no individual trees. There were a total of two trees 24 inches in diameter and greater on the subject property, one tree 24 inches or greater in diameter on the adjacent property to the west, and no heritage trees 36 inches in diameter or greater on or adjacent to the site. Oak woodland was determined to comprise 0.512 acres in the Study Area.

Implementation of the proposed project would impact 0.468 acres of the oak woodland.

Habitat Conservation Plans, Natural Community Conservation Plans, and Local Conservation Plans

There are no Habitat Conservation Plans or Natural Community Conservation Plans that cover the project site and the proposed project will have no impact on any such plans. The project site is located with El Dorado Rare Plant Mitigation Area 2, which requires mitigation for impacts to lands within western El Dorado County that are within the range of rare plants endemic to western El Dorado County, often referred to as the Pine Hill Plants. The project will be subject to payment of rare plant mitigation fees as applicable to Rare Plant Mitigation Area 2 as required by El Dorado County.

Summary of Potential Biological Impacts and Recommended Mitigation Measures

The proposed project could potentially result in impacts to nesting raptors and migratory birds and/or other nesting birds and would result in impacts to protected trees. The project site is also located within El Dorado County Rare Plant Mitigation Area 2. Recommended measures are included below to reduce potential impacts to less than significant.

Recommended Mitigation Measures

Nesting Birds

- Any vegetation clearing or ground disturbing activities within the Study Area should take place outside of the typical avian nesting season (e.g., February 15 through August 31), if feasible. If construction needs to commence between February 15 and August 31, a pre-construction survey for nesting birds should be conducted within 500 feet of active construction areas within 14 days prior to commencement of construction. If a lapse in Project activity occurs for 14 days or more during the bird nesting season then the nesting bird surveys should be re-conducted. If no nesting birds are observed no further mitigation is required.
- If active bird nests are observed during the pre-construction survey, a buffer zone should be established around the nest tree(s) until the young have fledged or are no longer dependent on the nest, as determined by a qualified biologist. The radius of the required buffer zone can vary depending on the species, (i.e., 25-100 feet for passerines and 200-300 feet for common raptors), with the dimensions of any required buffer zones to be determined by a qualified biologist. Buffer zones could be reduced if the nest is monitored by a qualified biologist.
- The buffer zone around a nesting tree should be demarcated with high visibility orange construction fencing (or similar highly visible material) and no construction activities or personnel should be allowed within the buffer zone.

Protected Trees

Mitigation for impacts to oak resources should be implemented in accordance with the County's ORMP at a 2:1 ratio, for a total acre mitigation amount of 0.936 acres at the current fee. At the time of report preparation, the fee for oak woodland impacts is \$8,285 per acre, for a total mitigation of \$7,638.77.

Rare Plant Mitigation

Payment of fees for development within El Dorado County Rare Plant Mitigation Area 2 should be implemented. The current fee for development of single-family residential in Mitigation Area 2 is \$386.00 per dwelling for a total mitigation of \$3,860.00.

References

- California Department of Fish and Wildlife (CDFW). 1994. Staff Report Regarding Mitigation for Impacts to Swainson's hawk (*Buteo swainsoni*) in the Central Valley of California. November 1.
2012. Staff Report on Burrowing Owl Mitigation. July.

2021. California Natural Diversity Database RareFind 5/BIOS, Sacramento, CA for the "Clarksville, CA" and "Shingle Springs, CA" USGS 7.5-minute series quadrangles. Accessed September 2021.
- California Tree and Landscape Consulting, Inc. (CalTLC). 2021. Arborist Report for Oak Woodland Resources, APN 082-411-004-000. Prepared August 2021 for Mr. Joe Jaoudi.
- California Herps. 2021. Online Species Accounts for Blainville's (Coast) Horned Lizard and California Yellow-Legged Frog. Available online at <<http://californiaherps.com>>
- California Native Plant Society (CNPS). 2021. Inventory of Rare and Endangered Plants (online edition, v8-03 0.39) for the "Clarksville, CA" and "Shingle Springs, CA" USGS 7.5-minute series quadrangles. Accessed September 2021.
- Cornell Lab. 2021. All About Birds Life History Account for Great Blue Heron. Accessed online September 2021 at:
<http://www.allaboutbirds.org/guide/Great_Blue_Heron/lifehistory>
- Jennings, M.R. and M.P. Hayes. 1994. Amphibian and Reptile Species of Special Concern in California. Final Report submitted to the California Department of Fish and [Wildlife], Inland Fisheries Division.
- Moyle, PB. 2002. Inland Fishes of California. University of California Press, Berkeley
- Natural Resources Conservation Service (NRCS). 2021. Web Soil Survey. Available online at: <https://websoilsurvey.sc.egov.usda.gov/App/WebSoilSurvey.aspx>. Accessed September 2021.
- Shuford, W.D., and T. Gardali, editors. 2008. California Bird Species of Special Concern: A Ranked Assessment of Species, Subspecies, and Distinct Populations of Birds of Immediate Conservation Concern in California. Studies of Western Birds 1. Western Field Ornithologists, Camarillo,
- U.S. Army Corps of Engineers (USACE). 1987. Wetlands Research Program Technical Report Y-87-1 Corps of Engineers Wetland Delineation Manual. January 1987.
2008. Regional Supplement to the Corps of Engineers Wetland Delineation Manual: Arid West Region (Version 2.0). J.S. Wakeley, R.W. Lichvar, and C.V. Noble, eds., Technical Report prepared for the U.S. Army Engineer Research and Development Center, Vicksburg, MS.
- U.S. Fish and Wildlife Service (USFWS). 2002. Recovery Plan for the California Red-legged Frog (*Rana aurora draytonii*). U.S. Fish and Wildlife Service, Portland, Oregon. viii + 173 pp.
2005. Recovery Plan for Vernal Pool Ecosystems of California and Southern Oregon. Region 1, U.S. Fish and Wildlife Service, Portland, OR.

2013. Recovery Plan for Tidal Marsh Ecosystems of Northern and Central California. Sacramento, California. xviii+ 605 pp.

2017a. Framework for Assessing Impacts to the Valley Elderberry Longhorn Beetle (*Desmocerus californicus dimorphus*). U.S. Fish and Wildlife Service; Sacramento, California. 28 pp

2017b. Recovery Plan for the Central California Distinct Population Segment of the California Tiger Salamander (*Ambystoma californiense*). U.S. Fish and Wildlife Service, Pacific Southwest Region, Sacramento, California. v + 69pp.

2017c. Recovery Plan for the Giant Garter Snake (*Thamnophis gigas*). U.S. Fish and Wildlife Service, Pacific Southwest Region, Sacramento, California. vii + 71 pp.

2019. Bald Eagle Fact Sheet: Natural History, Ecology, and Recovery. Revised July 2019. Available online at: <[https:// www.fws.gov/midwest/eagle/Nhistory/biologue.html](https://www.fws.gov/midwest/eagle/Nhistory/biologue.html)>

2021b. National Wetlands Inventory. Accessed online September 2021 at: <<http://www.fws.gov/wetlands/Data/mapper.html>>.

U.S. Forest Service (USFS). 2021. Fire Effects Information System species account for fisher (*Pekania pennanti*). Accessed September 2021 at: <<http://www.fs.fed.us/database/feis/animals/mammal/pepe/all.html#BiologicalDataAndHabitatRequirements>>

Zeiner, D.C., W.F. Laudenslayer, Jr., K.E. Mayer, and M. White, eds. 1988-1990. California's Wildlife. Vol. I-III. California Department of Fish and Game, Sacramento, California.

Attachment A: Figures

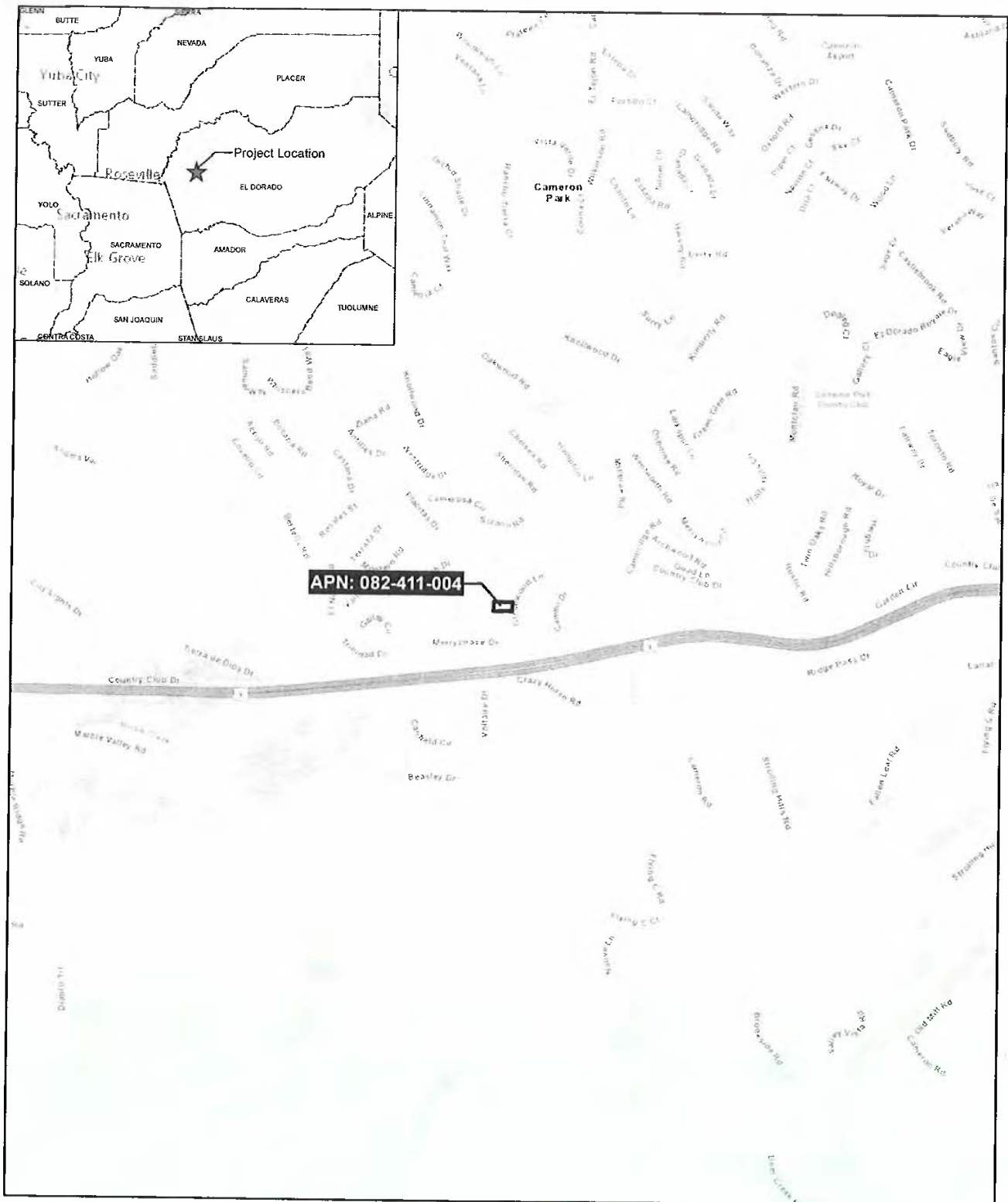

Figure 1
Regional Location and Vicinity

APN 082-411-004
2545 Greenwood Lane, Cameron Park, El Dorado County, CA

FREMONT
ENVIRONMENTAL
CONSULTING

Map Date: 09/01/2021
Source: ESRI (2021)



0 1,000 2,000
Feet

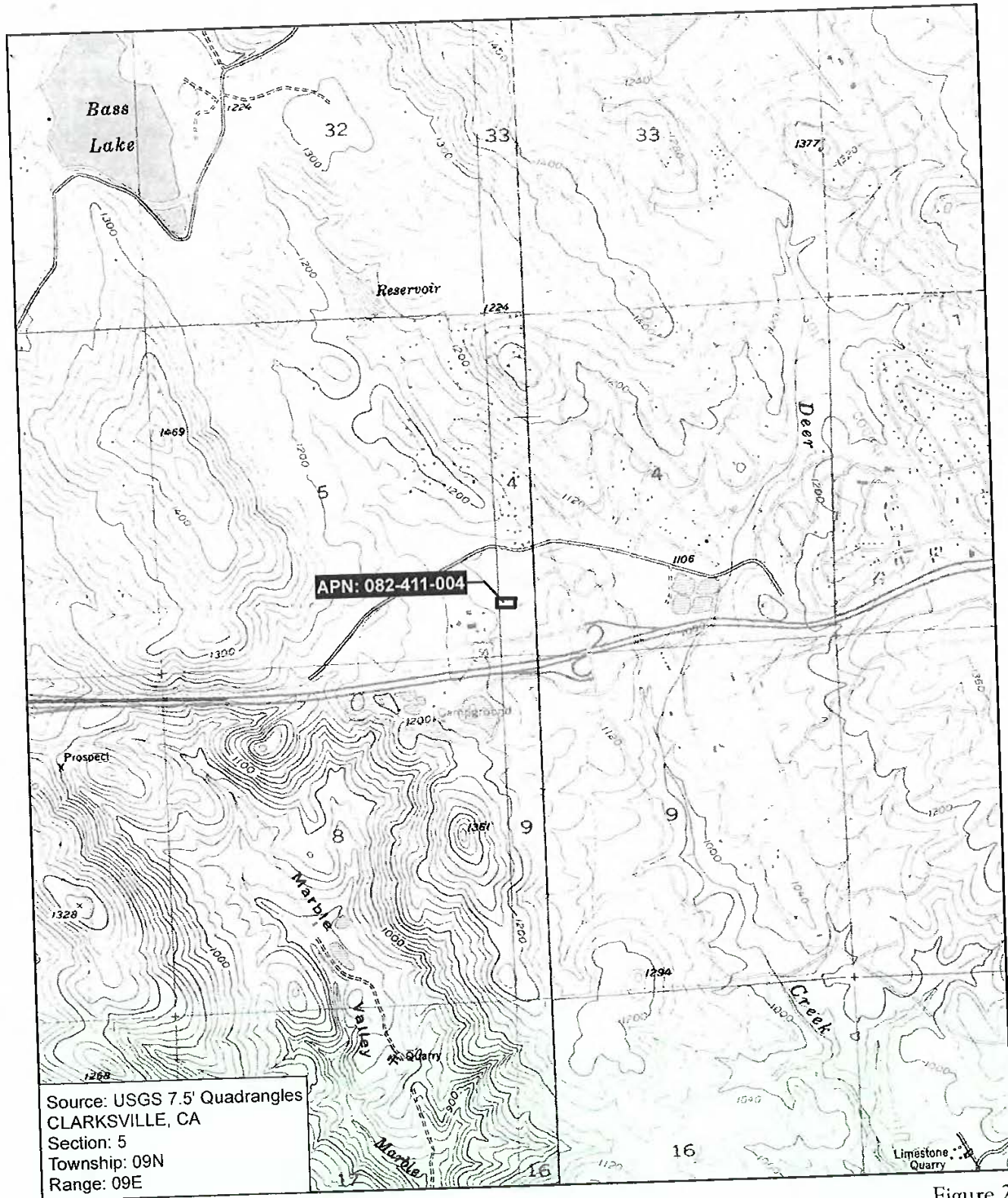
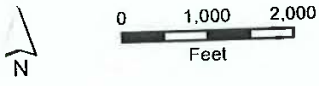

Figure 2
 USGS



PREMOG
 ENVIRONMENTAL
 CONSULTING

Map Date: 09/01/2021
 Source: USGS (2020)

APN 082-411-004
 2545 Greenwood Lane, Cameron Park, El Dorado County, CA

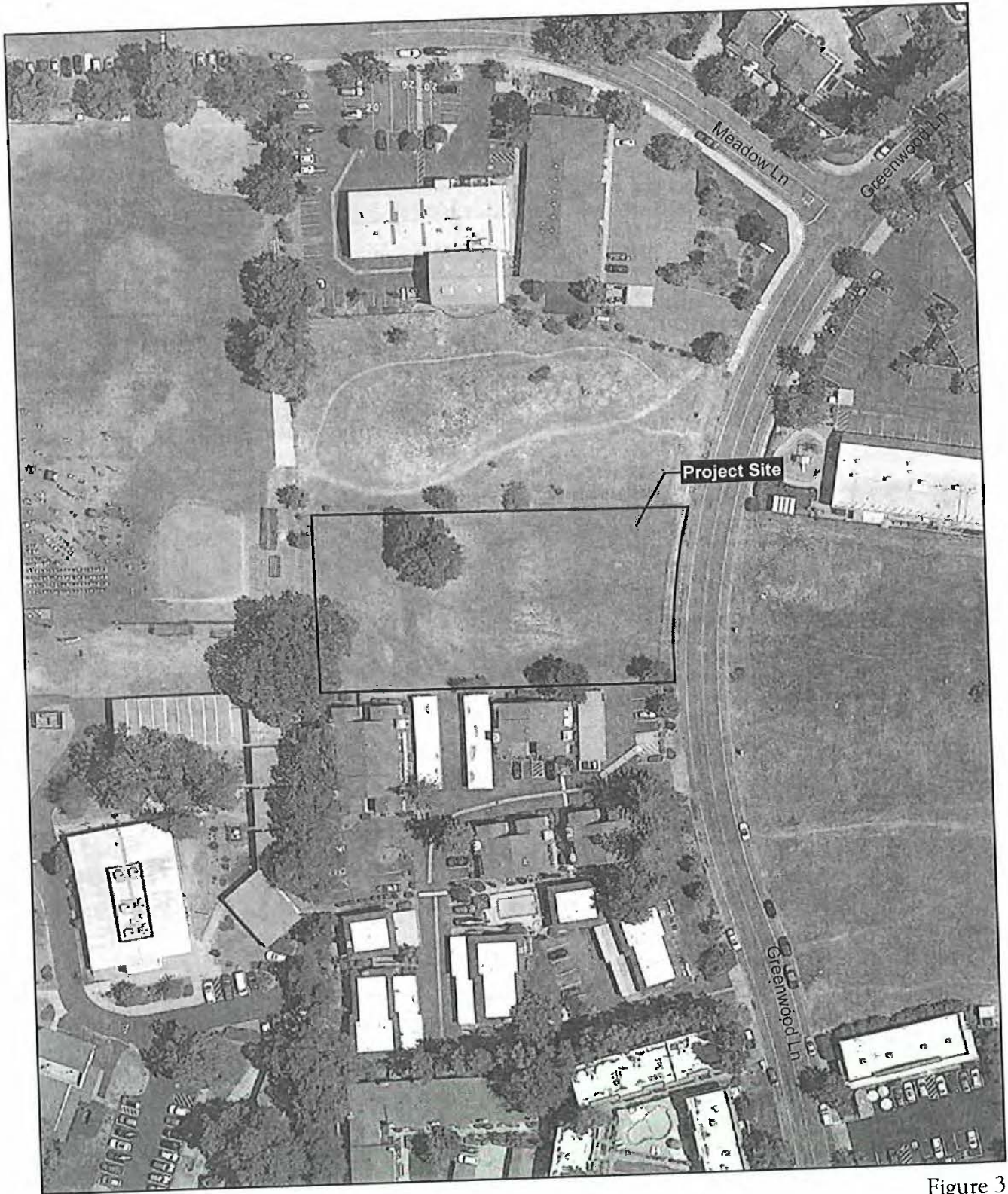

Figure 3

AERIAL

APN 082-411-004

2545 Greenwood Lane, Cameron Park, El Dorado County, CA



**PREMONTE
ENVIRONMENTAL
CONSULTING**

Map Date: 09/01/2021
Aerial Source: Google Earth (06/2021)

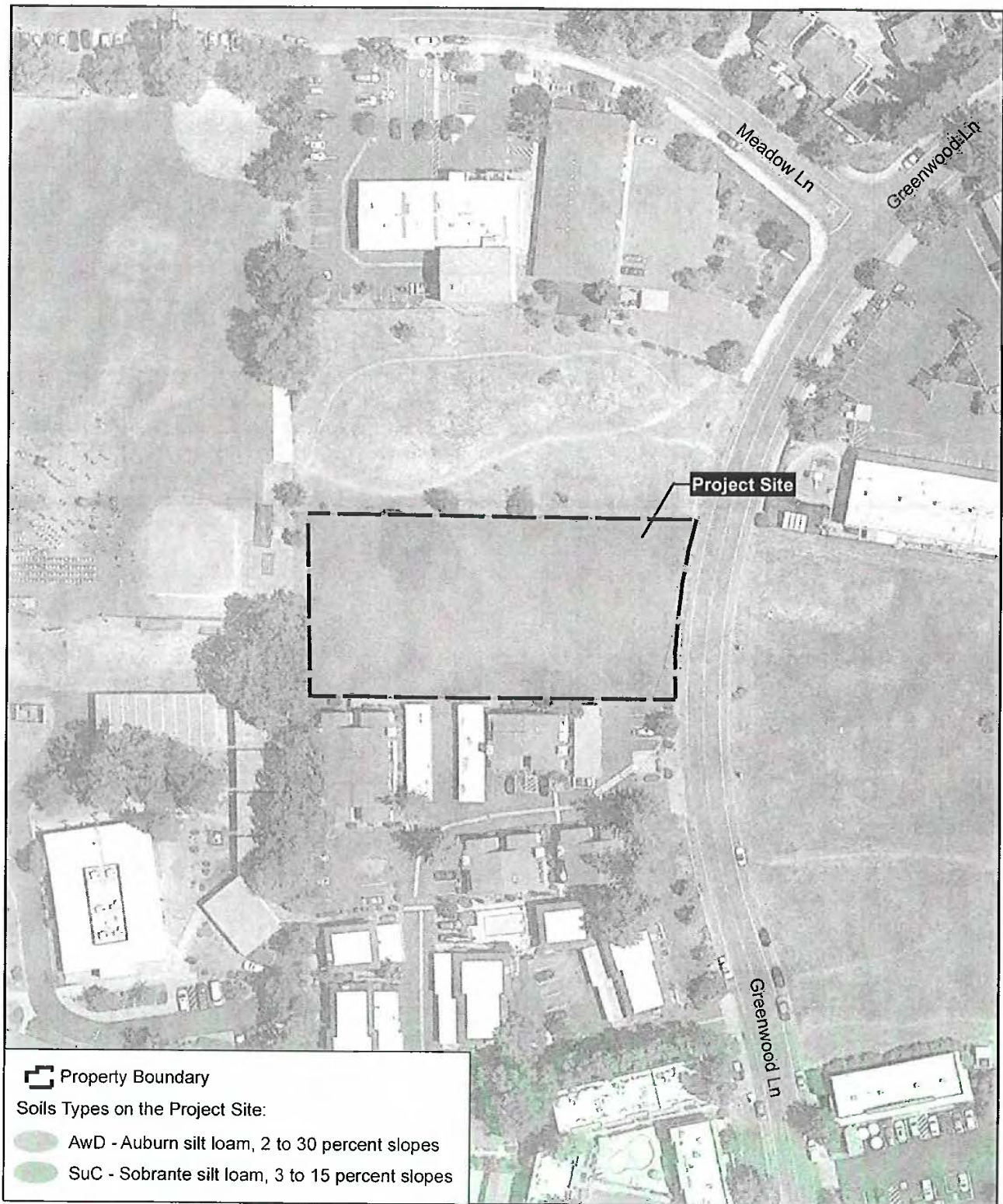

Figure 4

SOILS

APN 082-411-004

2545 Greenwood Lane, Cameron Park, El Dorado County, CA

**PREMONO
ENVIRONMENTAL
CONSULTING**

Map Date: 09/01/2021

Data Sources: Natural Resources Conservation Service (NRCS) (2021); Google Earth (06/2021)

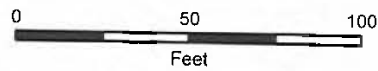
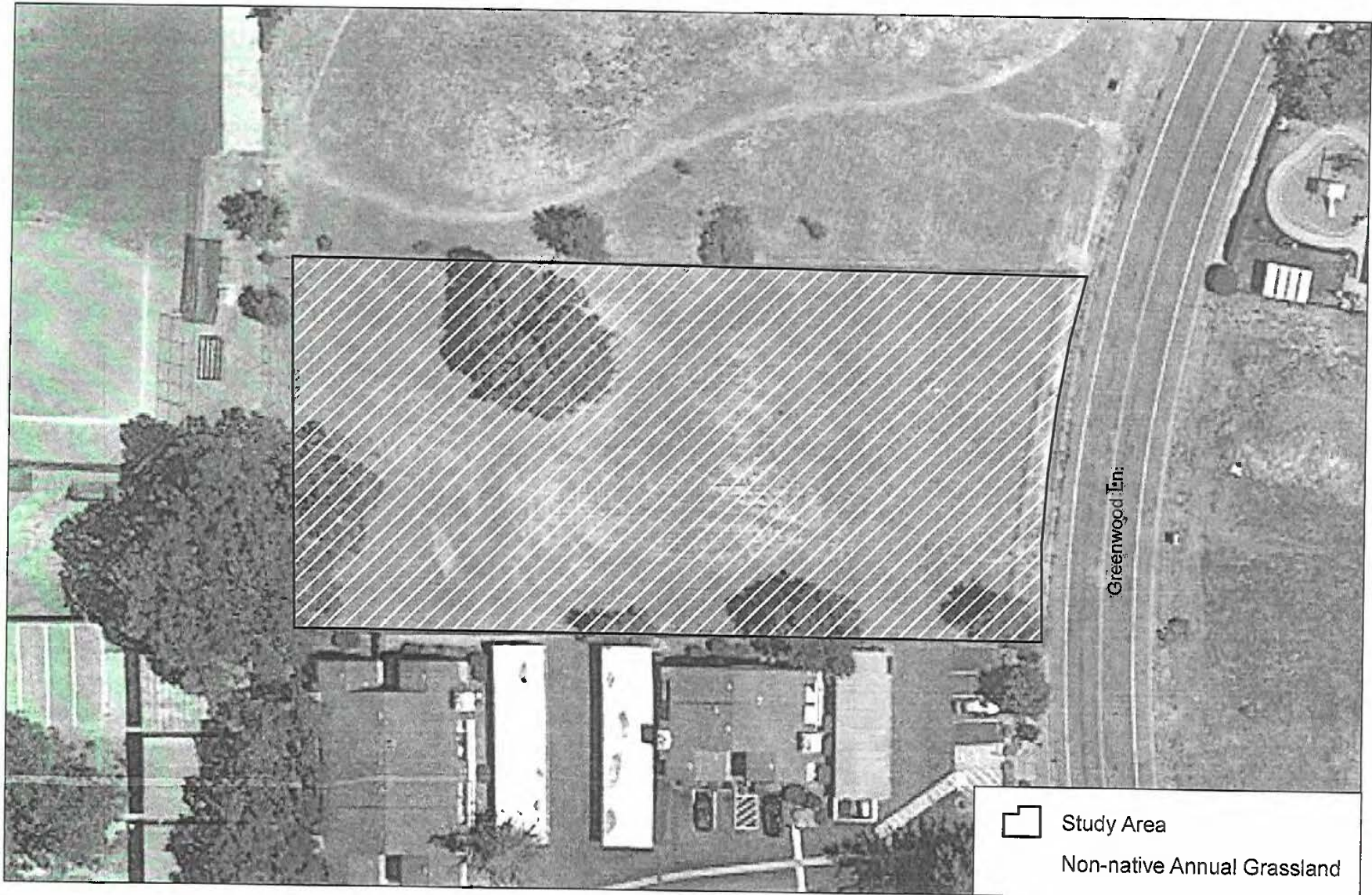

PERMONG
ENVIRONMENTAL
CONSULTING

Map Date: 09/09/2021
Aerial Source: Google Earth (06/2021)

Figure 5
Habitat Map

APN 082-411-004
2545 Greenwood Lane, Cameron Park, El Dorado County, CA



Viewpoint of the site to the west and to the south. Habitat consists of non-native annual grassland and a few scattered, non-heritage native oaks.

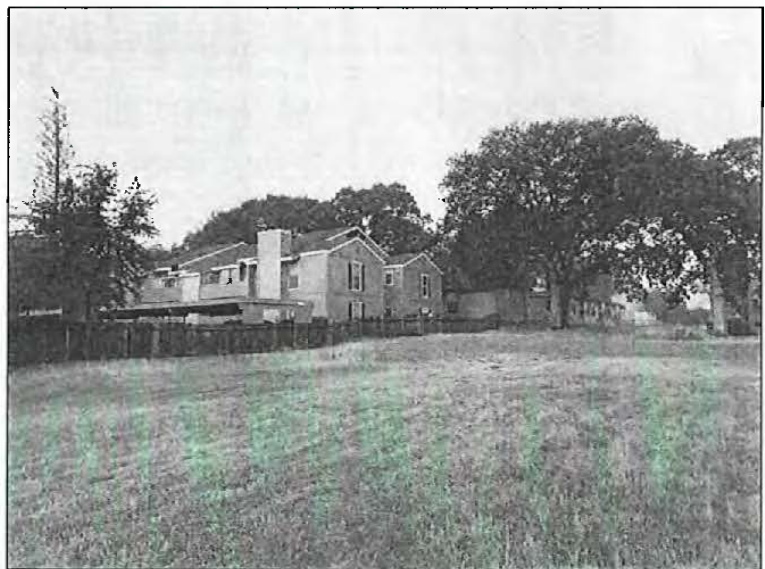

Photograph Date: 08/26/2021

Figure 6

Site Photographs

FREMONT
ENVIRONMENTAL
CONSULTING

APN 082411-004
2545 Greenwood Lane, Cameron Park, El Dorado County, CA

Attachment B: Special-Status Species Queries



Selected Elements by Common Name
California Department of Fish and Wildlife
California Natural Diversity Database



Query Criteria: Quad IS (Clarksville (3812161) OR Shingle Springs (3812068))

Species	Element Code	Federal Status	State Status	Global Rank	State Rank	Rare Plant Rank/CDFW SSC or FP
bald eagle <i>Haliaeetus leucocephalus</i>	ABNKC10010	Delisted	Endangered	G5	S3	FP
bank swallow <i>Riparia riparia</i>	ABPAU08010	None	Threatened	G5	S2	
Bisbee Peak rush-rose <i>Crocانthemum suffrutescens</i>	PDCIS020F0	None	None	G2?Q	S2?	3.2
Blennosperma vernal pool andrenid bee <i>Andrena blennospermatis</i>	IIHYM35030	None	None	G2	S2	
Brandegee's clarkia <i>Clarkia biloba ssp. brandegeae</i>	PDONA05053	None	None	G4G5T4	S4	4.2
burrowing owl <i>Athene cunicularia</i>	ABNSB10010	None	None	G4	S3	SSC
California black rail <i>Laterallus jamaicensis coturniculus</i>	ABNME03041	None	Threatened	G3G4T1	S1	FP
California red-legged frog <i>Rana draytonii</i>	AAABH01022	Threatened	None	G2G3	S2S3	SSC
chaparral sedge <i>Carex xerophila</i>	PMCYP03M60	None	None	G2	S2	1B.2
coast horned lizard <i>Phrynosoma blainvillii</i>	ARACF12100	None	None	G3G4	S3S4	SSC
EI Dorado bedstraw <i>Galium californicum ssp. sierrae</i>	PDRUB0N0E7	Endangered	Rare	G5T1	S1	1B.2
EI Dorado County mule ears <i>Wyethia reticulata</i>	PDAST9X0D0	None	None	G2	S2	1B.2
Fisher <i>Pekania pennanti</i>	AMAJF01020	None	None	G5	S2S3	SSC
foothill yellow-legged frog <i>Rana boylei</i>	AAABH01050	None	Endangered	G3	S3	SSC
golden eagle <i>Aquila chrysaetos</i>	ABNKC22010	None	None	G5	S3	FP
great blue heron <i>Ardea herodias</i>	ABNGA04010	None	None	G5	S4	
great egret <i>Ardea alba</i>	ABNGA04040	None	None	G5	S4	
Jepson's onion <i>Allium jepsonii</i>	PMLIL022V0	None	None	G2	S2	1B.2
Layne's ragwort <i>Packera layneae</i>	PDAST8H1V0	Threatened	Rare	G2	S2	1B.2
North American porcupine <i>Erethizon dorsatum</i>	AMAFJ01010	None	None	G5	S3	



Selected Elements by Common Name
California Department of Fish and Wildlife
California Natural Diversity Database



Species	Element Code	Federal Status	State Status	Global Rank	State Rank	Rare Plant Rank/CDFW SSC or FP
Pine Hill ceanothus <i>Ceanothus roderickii</i>	PDRHA04190	Endangered	Rare	G1	S1	1B.1
Pine Hill flannelbush <i>Fremontodendron decumbens</i>	PDSTE03030	Endangered	Rare	G1	S1	1B.2
Red Hills soaproot <i>Chlorogalum grandiflorum</i>	PMLIL0G020	None	None	G3	S3	1B.2
Ricksecker's water scavenger beetle <i>Hydrochara rickseckeri</i>	IICOL5V010	None	None	G2?	S2?	
Sanford's arrowhead <i>Sagittaria sanfordii</i>	PMALI040Q0	None	None	G3	S3	1B.2
Stebbins' morning-glory <i>Calystegia stebbinsii</i>	PDCON040H0	Endangered	Endangered	G1	S1	1B.1
tricolored blackbird <i>Agelaius tricolor</i>	ABPBXB0020	None	Threatened	G1G2	S1S2	SSC
valley elderberry longhorn beetle <i>Desmocerus californicus dimorphus</i>	IICOL48011	Threatened	None	G3T2	S3	
vernal pool fairy shrimp <i>Branchinecta lynchi</i>	ICBRA03030	Threatened	None	G3	S3	
western pond turtle <i>Emys marmorata</i>	ARAAD02030	None	None	G3G4	S3	SSC
western spadefoot <i>Spea hammondi</i>	AAABF02020	None	None	G2G3	S3	SSC
white-tailed kite <i>Elanus leucurus</i>	ABNKC06010	None	None	G5	S3S4	FP

Record Count: 32

Simple
Advanced

Search for species

Its

Sort Results

and. Click on scientific name for details

Quad is one of [3812161,3812068]

Rank
 Common Name
 Family
 Lifeform
 Blooming Period
 Fed List
 State List
 Global Rank
 State Rank
 General Habitats
 Micro Habitats
 Lowest Elevation
 Highest Elevation
 CA Endemic
 Date Added
 Photo

NAME	COMMON NAME	FAMILY	LIFEFORM	BLOOMING PERIOD	FED LIST	STATE LIST	GLOBAL RANK	STATE RANK	CA RAR PLANT RANK
j	Jepson's onion	Alliaceae	perennial bulbiferous herb	Apr-Aug	None	None	G2	S2	1B.2
reweri	Brewer's calandrinia	Montiaceae	annual herb	(Jan)Mar-Jun	None	None	G4	S4	4.2
stebbinsii	Stebbins' morning-glory	Convolvulaceae	perennial rhizomatous herb	Apr-Jul	FE	CE	G1	S1	1B.1
									
									
									
									
									
									
									
									
									
									

<i>drum</i>	Pine Hill flannelbush	Malvaceae	perennial evergreen shrub	Apr-Jul	FE	CR	G1	S1	1B.2
<i>panicum</i>	El Dorado bedstraw	Rubiaceae	perennial herb	May-Jun	FE	CR	G5T1	S1	1B.2
<i>chella</i> <i>nicola</i>	serpentine bluecup	Campanulaceae	annual herb	May-Jun	None	None	G4T3	S3	4.3
<i>'a</i>	coast iris	Iridaceae	perennial rhizomatous herb	Mar- May(Jun)	None	None	G3	S3	4.2
<i>ae</i>	Layne's ragwort	Asteraceae	perennial herb	Apr-Aug	FT	CR	G2	S2	1B.2
<i>iflora</i>	beautiful shootingstar	Primulaceae	perennial herb	Apr-Jun	None	None	G5	S3	4.2
<i>fordii</i>	Sanford's arrowhead	Alismataceae	perennial rhizomatous	May- Oct(Nov)	None	None	G3	S3	1B.2

IPaC resource list

This report is an automatically generated list of species and other resources such as critical habitat (collectively referred to as *trust resources*) under the U.S. Fish and Wildlife Service's (USFWS) jurisdiction that are known or expected to be on or near the project area referenced below. The list may also include trust resources that occur outside of the project area, but that could potentially be directly or indirectly affected by activities in the project area. However, determining the likelihood and extent of effects a project may have on trust resources typically requires gathering additional site-specific (e.g., vegetation/species surveys) and project-specific (e.g., magnitude and timing of proposed activities) information.

Below is a summary of the project information you provided and contact information for the USFWS office(s) with jurisdiction in the defined project area. Please read the introduction to each section that follows (Endangered Species, Migratory Birds, USFWS Facilities, and NWI Wetlands) for additional information applicable to the trust resources addressed in that section.

Location

El Dorado County, California

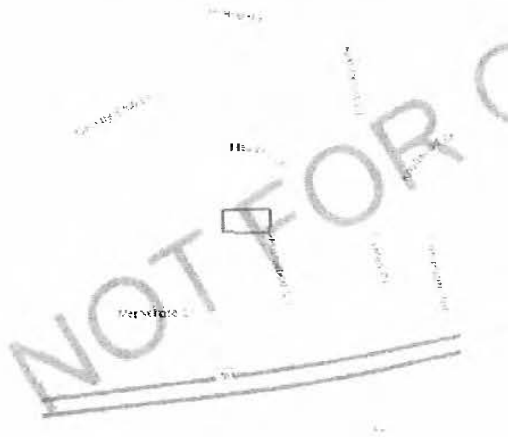

Local office

Sacramento Fish And Wildlife Office

☎ (916) 414-6600

📠 (916) 414-6713

Federal Building
2800 Cottage Way, Room W-2605
Sacramento, CA 95825-1846

Endangered species

This resource list is for informational purposes only and does not constitute an analysis of project level impacts.

The primary information used to generate this list is the known or expected range of each species. Additional areas of influence (AOI) for species are also considered. An AOI includes areas outside of the species range if the species could be indirectly affected by activities in that area (e.g., placing a dam upstream of a fish population even if that fish does not occur at the dam site, may indirectly impact the species by reducing or eliminating water flow downstream). Because species can move, and site conditions can change, the species on this list are not guaranteed to be found on or near the project area. To fully determine any potential effects to species, additional site-specific and project-specific information is often required.

Section 7 of the Endangered Species Act requires Federal agencies to "request of the Secretary information whether any species which is listed or proposed to be listed may be present in the area of such proposed action" for any project that is conducted, permitted, funded, or licensed by any Federal agency. A letter from the local office and a species list which fulfills this requirement can **only** be obtained by requesting an official species list from either the Regulatory Review section in IPaC (see directions below) or from the local field office directly.

For project evaluations that require USFWS concurrence/review, please return to the IPaC website and request an official species list by doing the following:

1. Draw the project location and click CONTINUE.
2. Click DEFINE PROJECT.
3. Log in (if directed to do so).
4. Provide a name and description for your project.
5. Click REQUEST SPECIES LIST.

Listed species¹ and their critical habitats are managed by the [Ecological Services Program](#) of the U.S. Fish and Wildlife Service (USFWS) and the fisheries division of the National Oceanic and Atmospheric Administration (NOAA Fisheries²).

Species and critical habitats under the sole responsibility of NOAA Fisheries are not shown on this list. Please contact [NOAA Fisheries](#) for [species under their jurisdiction](#).

1. Species listed under the [Endangered Species Act](#) are threatened or endangered; IPaC also shows species that are candidates, or proposed, for listing. See the [listing status page](#) for more information. IPaC only shows species that are regulated by USFWS (see FAQ).
2. [NOAA Fisheries](#), also known as the National Marine Fisheries Service (NMFS), is an office of the National Oceanic and Atmospheric Administration within the Department of Commerce.

The following species are potentially affected by activities in this location:

Reptiles

NAME

STATUS

Giant Garter Snake *Thamnophis gigas*

Threatened

Wherever found

No critical habitat has been designated for this species.

<https://ecos.fws.gov/ecp/species/4482>

Amphibians

NAME

STATUS

California Red-legged Frog *Rana draytonii*

Threatened

Wherever found

There is **final** critical habitat for this species. The location of the critical habitat is not available.

<https://ecos.fws.gov/ecp/species/2891>

California Tiger Salamander *Ambystoma californiense*

Threatened

There is **final** critical habitat for this species. The location of the critical habitat is not available.

<https://ecos.fws.gov/ecp/species/2076>

Fishes

NAME

STATUS

Delta Smelt *Hypomesus transpacificus*

Threatened

Wherever found

There is **final** critical habitat for this species. The location of the critical habitat is not available.

<https://ecos.fws.gov/ecp/species/321>

Insects

NAME

STATUS

Valley Elderberry Longhorn Beetle *Desmocerus californicus dimorphus*

Threatened

Wherever found

There is **final** critical habitat for this species. The location of the critical habitat is not available.

<https://ecos.fws.gov/ecp/species/7850>

Crustaceans

NAME

STATUS

Vernal Pool Fairy Shrimp *Branchinecta lynchi*

Threatened

Wherever found

There is **final** critical habitat for this species. The location of the critical habitat is not available.

<https://ecos.fws.gov/ecp/species/498>

Vernal Pool Tadpole Shrimp *Lepidurus packardii*

Endangered

Wherever found

There is final critical habitat for this species. The location of the critical habitat is not available.

<https://ecos.fws.gov/ecp/species/2246>

Flowering Plants

NAME

STATUS

El Dorado Bedstraw *Galium californicum* ssp. *sierrae*

Endangered

Wherever found

No critical habitat has been designated for this species.

<https://ecos.fws.gov/ecp/species/5209>

Layne's Butterweed *Senecio layneae*

Threatened

Wherever found

No critical habitat has been designated for this species.

<https://ecos.fws.gov/ecp/species/4062>

Pine Hill Ceanothus *Ceanothus roderickii*

Endangered

Wherever found

No critical habitat has been designated for this species.

<https://ecos.fws.gov/ecp/species/3293>

Pine Hill Flannelbush *Fremontodendron californicum* ssp.

Endangered

decumbens

Wherever found

No critical habitat has been designated for this species.

<https://ecos.fws.gov/ecp/species/4818>

Stebbins' Morning-glory *Calystegia stebbinsii*

Endangered

Wherever found

No critical habitat has been designated for this species.

<https://ecos.fws.gov/ecp/species/3991>

Critical habitats

Potential effects to critical habitat(s) in this location must be analyzed along with the endangered species themselves.

THERE ARE NO CRITICAL HABITATS AT THIS LOCATION.

Migratory birds

Certain birds are protected under the Migratory Bird Treaty Act¹ and the Bald and Golden Eagle Protection Act².

Any person or organization who plans or conducts activities that may result in impacts to migratory birds, eagles, and their habitats should follow appropriate regulations and consider implementing appropriate conservation measures, as described below.

1. The Migratory Birds Treaty Act of 1918.
2. The Bald and Golden Eagle Protection Act of 1940.

Additional information can be found using the following links:

- Birds of Conservation Concern <http://www.fws.gov/birds/management/managed-species/birds-of-conservation-concern.php>
- Measures for avoiding and minimizing impacts to birds <http://www.fws.gov/birds/management/project-assessment-tools-and-guidance/conservation-measures.php>
- Nationwide conservation measures for birds <http://www.fws.gov/migratorybirds/pdf/management/nationwidestandardconservationmeasures.pdf>

The birds listed below are birds of particular concern either because they occur on the USFWS Birds of Conservation Concern (BCC) list or warrant special attention in your project location. To learn more about the levels of concern for birds on your list and how this list is generated, see the FAQ below. This is not a list of every bird you may find in this location, nor a guarantee that every bird on this list will be found in your project area. To see exact locations of where birders and the general public have sighted birds in and around your project area, visit the E-bird data mapping tool (Tip: enter your location, desired date range and a species on your list). For projects that occur off the Atlantic Coast, additional maps and models detailing the relative occurrence and abundance of bird species on your list are available. Links to additional information about Atlantic Coast birds, and other important information about your migratory bird list, including how to properly interpret and use your migratory bird report, can be found below.

For guidance on when to schedule activities or implement avoidance and minimization measures to reduce impacts to migratory birds on your list, click on the PROBABILITY OF PRESENCE SUMMARY at the top of your list to see when these birds are most likely to be present and breeding in your project area.

NAME

BREEDING SEASON (IF A BREEDING SEASON IS INDICATED FOR A BIRD ON YOUR LIST, THE BIRD MAY BREED IN YOUR PROJECT AREA SOMETIME WITHIN THE TIMEFRAME SPECIFIED, WHICH IS A VERY LIBERAL ESTIMATE OF THE DATES INSIDE WHICH THE BIRD BREEDS ACROSS ITS ENTIRE RANGE. "BREEDS ELSEWHERE" INDICATES

THAT THE BIRD DOES NOT LIKELY
BREED IN YOUR PROJECT AREA.)

Bald Eagle *Haliaeetus leucocephalus*

This is not a Bird of Conservation Concern (BCC) in this area, but warrants attention because of the Eagle Act or for potential susceptibilities in offshore areas from certain types of development or activities.

<https://ecos.fws.gov/ecp/species/1626>

Breeds Jan 1 to Aug 31

Black Tern *Chlidonias niger*

This is a Bird of Conservation Concern (BCC) throughout its range in the continental USA and Alaska.

<https://ecos.fws.gov/ecp/species/3093>

Breeds May 15 to Aug 20

California Thrasher *Toxostoma redivivum*

This is a Bird of Conservation Concern (BCC) throughout its range in the continental USA and Alaska.

Breeds Jan 1 to Jul 31

Cassin's Finch *Carpodacus cassinii*

This is a Bird of Conservation Concern (BCC) throughout its range in the continental USA and Alaska.

<https://ecos.fws.gov/ecp/species/9462>

Breeds May 15 to Jul 15

Golden Eagle *Aquila chrysaetos*

This is not a Bird of Conservation Concern (BCC) in this area, but warrants attention because of the Eagle Act or for potential susceptibilities in offshore areas from certain types of development or activities.

<https://ecos.fws.gov/ecp/species/1680>

Breeds Jan 1 to Aug 31

Lawrence's Goldfinch *Carduelis lawrencei*

This is a Bird of Conservation Concern (BCC) throughout its range in the continental USA and Alaska.

<https://ecos.fws.gov/ecp/species/9464>

Breeds Mar 20 to Sep 20

Nuttall's Woodpecker *Picoides nuttallii*

This is a Bird of Conservation Concern (BCC) only in particular Bird Conservation Regions (BCRs) in the continental USA

<https://ecos.fws.gov/ecp/species/9410>

Breeds Apr 1 to Jul 20

Oak Titmouse *Baeolophus inornatus*

This is a Bird of Conservation Concern (BCC) throughout its range in the continental USA and Alaska.

<https://ecos.fws.gov/ecp/species/9656>

Breeds Mar 15 to Jul 15

Olive-sided Flycatcher *Contopus cooperi*

Breeds May 20 to Aug 31

This is a Bird of Conservation Concern (BCC) throughout its range in the continental USA and Alaska.

<https://ecos.fws.gov/ecp/species/3914>

Wrentit *Chamaea fasciata*

Breeds Mar 15 to Aug 10

This is a Bird of Conservation Concern (BCC) throughout its range in the continental USA and Alaska.

Yellow-billed Magpie *Pica nuttalli*

Breeds Apr 1 to Jul 31

This is a Bird of Conservation Concern (BCC) throughout its range in the continental USA and Alaska.

<https://ecos.fws.gov/ecp/species/9726>

Probability of Presence Summary

The graphs below provide our best understanding of when birds of concern are most likely to be present in your project area. This information can be used to tailor and schedule your project activities to avoid or minimize impacts to birds. Please make sure you read and understand the FAQ "Proper Interpretation and Use of Your Migratory Bird Report" before using or attempting to interpret this report.

Probability of Presence ()

Each green bar represents the bird's relative probability of presence in the 10km grid cell(s) your project overlaps during a particular week of the year. (A year is represented as 12 4-week months.) A taller bar indicates a higher probability of species presence. The survey effort (see below) can be used to establish a level of confidence in the presence score. One can have higher confidence in the presence score if the corresponding survey effort is also high.

How is the probability of presence score calculated? The calculation is done in three steps:

1. The probability of presence for each week is calculated as the number of survey events in the week where the species was detected divided by the total number of survey events for that week. For example, if in week 12 there were 20 survey events and the Spotted Towhee was found in 5 of them, the probability of presence of the Spotted Towhee in week 12 is 0.25.
2. To properly present the pattern of presence across the year, the relative probability of presence is calculated. This is the probability of presence divided by the maximum probability of presence across all weeks. For example, imagine the probability of presence in week 20 for the Spotted Towhee is 0.05, and that the probability of presence at week 12 (0.25) is the maximum of any week of the year. The relative probability of presence on week 12 is $0.25/0.25 = 1$; at week 20 it is $0.05/0.25 = 0.2$.
3. The relative probability of presence calculated in the previous step undergoes a statistical conversion so that all possible values fall between 0 and 10, inclusive. This is the probability of presence score.

To see a bar's probability of presence score, simply hover your mouse cursor over the bar.

Breeding Season ()

Yellow bars denote a very liberal estimate of the time-frame inside which the bird breeds across its entire range. If there are no yellow bars shown for a bird, it does not breed in your project area.

Survey Effort (I)

Vertical black lines superimposed on probability of presence bars indicate the number of surveys performed for that species in the 10km grid cell(s) your project area overlaps. The number of surveys is expressed as a range, for example, 33 to 64 surveys.

To see a bar's survey effort range, simply hover your mouse cursor over the bar.

No Data (-)

A week is marked as having no data if there were no survey events for that week.

Survey Timeframe

Surveys from only the last 10 years are used in order to ensure delivery of currently relevant information. The exception to this is areas off the Atlantic coast, where bird returns are based on all years of available data, since data in these areas is currently much more sparse.

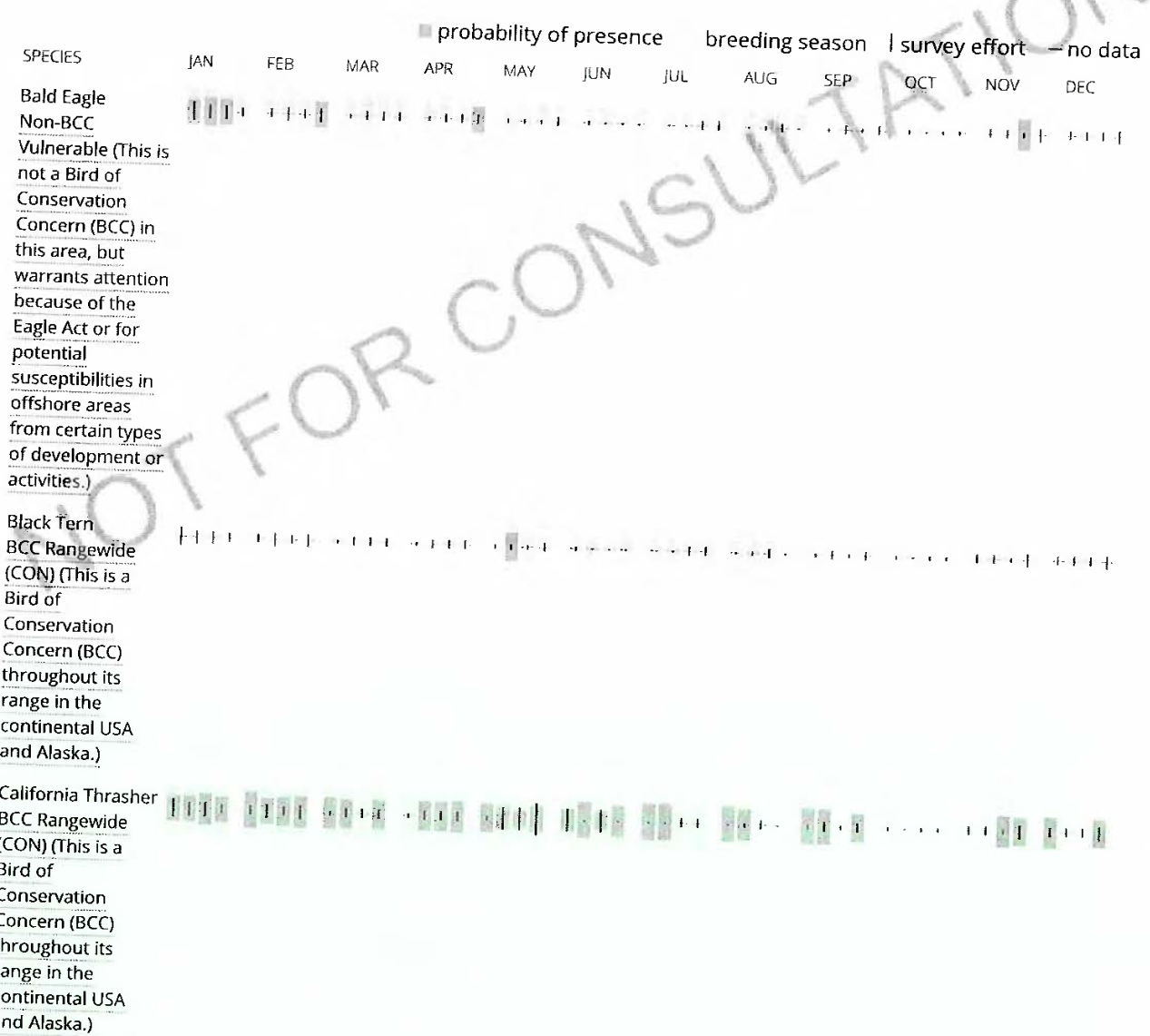

Cassin's Finch
BCC Rangewide
(CON) (This is a
Bird of
Conservation
Concern (BCC)
throughout its
range in the
continental USA
and Alaska.)



Golden Eagle
Non-BCC
Vulnerable (This is
not a Bird of
Conservation
Concern (BCC) in
this area, but
warrants attention
because of the
Eagle Act or for
potential
susceptibilities in
offshore areas
from certain types
of development or
activities.)



Lawrence's
Goldfinch
BCC Rangewide
(CON) (This is a
Bird of
Conservation
Concern (BCC)
throughout its
range in the
continental USA
and Alaska.)

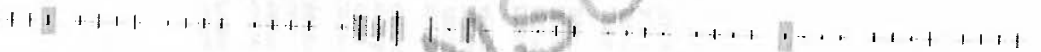

Nuttall's
Woodpecker
BCC - BCR (This is a
Bird of
Conservation
Concern (BCC) only
in particular Bird
Conservation
Regions (BCRs) in
the continental
USA)



Oak Titmouse
BCC Rangewide
(CON) (This is a
Bird of
Conservation
Concern (BCC)
throughout its
range in the
continental USA
and Alaska.)



NOT FOR CONSULTATION

Olive-sided Flycatcher
BCC Rangewide (CON) (This is a Bird of Conservation Concern (BCC) throughout its range in the continental USA and Alaska.)



Wrentit
BCC Rangewide (CON) (This is a Bird of Conservation Concern (BCC) throughout its range in the continental USA and Alaska.)



Yellow-billed Magpie
BCC Rangewide (CON) (This is a Bird of Conservation Concern (BCC) throughout its range in the continental USA and Alaska.)



FOR CONSULTATION

Tell me more about conservation measures I can implement to avoid or minimize impacts to migratory birds.

Nationwide Conservation Measures describes measures that can help avoid and minimize impacts to all birds at any location year round. Implementation of these measures is particularly important when birds are most likely to occur in the project area. When birds may be breeding in the area, identifying the locations of any active nests and avoiding their destruction is a very helpful impact minimization measure. To see when birds are most likely to occur and be breeding in your project area, view the Probability of Presence Summary. Additional measures or permits may be advisable depending on the type of activity you are conducting and the type of infrastructure or bird species present on your project site.

What does IPaC use to generate the migratory birds potentially occurring in my specified location?

The Migratory Bird Resource List is comprised of USFWS Birds of Conservation Concern (BCC) and other species that may warrant special attention in your project location.

The migratory bird list generated for your project is derived from data provided by the Avian Knowledge Network (AKN). The AKN data is based on a growing collection of survey, banding, and citizen science datasets and is queried and filtered to return a list of those birds reported as occurring in the 10km grid cell(s) which your project intersects, and that have been identified as warranting special attention because they are a BCC species in that area, an eagle (Eagle Act requirements may apply), or a species that has a particular vulnerability to offshore activities or development.

Again, the Migratory Bird Resource list includes only a subset of birds that may occur in your project area. It is not representative of all birds that may occur in your project area. To get a list of all birds potentially present in your project area, please visit the AKN Phenology Tool.

<https://ecos.fws.gov/ipac/location/5FPMJUOXFBEF5NXVEIDFEP6KRA/resources>

What does IPaC use to generate the probability of presence graphs for the migratory birds potentially occurring in my specified location?

The probability of presence graphs associated with your migratory bird list are based on data provided by the Avian Knowledge Network (AKN). This data is derived from a growing collection of survey, banding, and citizen science datasets.

Probability of presence data is continuously being updated as new and better information becomes available. To learn more about how the probability of presence graphs are produced and how to interpret them, go the Probability of Presence Summary and then click on the "Tell me about these graphs" link.

How do I know if a bird is breeding, wintering, migrating or present year-round in my project area?

To see what part of a particular bird's range your project area falls within (i.e. breeding, wintering, migrating or year-round), you may refer to the following resources: The Cornell Lab of Ornithology All About Birds Bird Guide, or (if you are unsuccessful in locating the bird of interest there), the Cornell Lab of Ornithology Neotropical Birds guide. If a bird on your migratory bird species list has a breeding season associated with it, if that bird does occur in your project area, there may be nests present at some point within the timeframe specified. If "Breeds elsewhere" is indicated, then the bird likely does not breed in your project area.

What are the levels of concern for migratory birds?

Migratory birds delivered through IPaC fall into the following distinct categories of concern:

1. "BCC Rangewide" birds are Birds of Conservation Concern (BCC) that are of concern throughout their range anywhere within the USA (including Hawaii, the Pacific Islands, Puerto Rico, and the Virgin Islands);
2. "BCC - BCR" birds are BCCs that are of concern only in particular Bird Conservation Regions (BCRs) in the continental USA; and
3. "Non-BCC - Vulnerable" birds are not BCC species in your project area, but appear on your list either because of the Eagle Act requirements (for eagles) or (for non-eagles) potential susceptibilities in offshore areas from certain types of development or activities (e.g. offshore energy development or longline fishing).

Although it is important to try to avoid and minimize impacts to all birds, efforts should be made, in particular, to avoid and minimize impacts to the birds on this list, especially eagles and BCC species of rangewide concern. For more information on conservation measures you can implement to help avoid and minimize migratory bird impacts and requirements for eagles, please see the FAQs for these topics.

Details about birds that are potentially affected by offshore projects

For additional details about the relative occurrence and abundance of both individual bird species and groups of bird species within your project area off the Atlantic Coast, please visit the Northeast Ocean Data Portal. The Portal also offers data and information about other taxa besides birds that may be helpful to you in your project review. Alternately, you may download the bird model results files underlying the portal maps through the NOAA NCCOS Integrative Statistical Modeling and Predictive Mapping of Marine Bird Distributions and Abundance on the Atlantic Outer Continental Shelf project webpage.

Bird tracking data can also provide additional details about occurrence and habitat use throughout the year, including migration. Models relying on survey data may not include this information. For additional information on marine bird tracking data, see the Diving Bird Study and the nanotag studies or contact Caleb Spiegel or Pam Loring.

What if I have eagles on my list?

If your project has the potential to disturb or kill eagles, you may need to obtain a permit to avoid violating the Eagle Act should such impacts occur.

Proper Interpretation and Use of Your Migratory Bird Report

The migratory bird list generated is not a list of all birds in your project area, only a subset of birds of priority concern. To learn more about how your list is generated, and see options for identifying what other birds may be in your project area, please see the FAQ "What does IPaC use to generate the migratory birds potentially occurring in my specified location". Please be aware this report provides the "probability of presence" of birds within the 10 km grid cell(s) that overlap your project; not your exact project footprint. On the graphs provided, please also look carefully at the survey effort (indicated by the black vertical bar) and for the existence of the "no data" indicator (a red horizontal bar). A high survey effort is the key component. If the survey effort is high, then the probability of presence score can be viewed as more dependable. In contrast, a low survey effort bar or no data bar means a lack of data and, therefore, a lack of certainty about presence of the species. This list is not perfect; it is simply a starting point for identifying what birds of concern have the potential to be in your project area, when they might be there, and if they might be breeding (which means nests might be present). The list helps you know what to look for to confirm presence, and helps guide you in knowing when to implement conservation measures to avoid or minimize potential impacts from your project activities, should presence be confirmed. To learn more about conservation measures, visit the FAQ "Tell me about conservation measures I can implement to avoid or minimize impacts to migratory birds" at the bottom of your migratory bird trust resources page.

Facilities

National Wildlife Refuge lands

Any activity proposed on lands managed by the National Wildlife Refuge system must undergo a 'Compatibility Determination' conducted by the Refuge. Please contact the individual Refuges to discuss any questions or concerns.

THERE ARE NO REFUGE LANDS AT THIS LOCATION.

Fish hatcheries

THERE ARE NO FISH HATCHERIES AT THIS LOCATION.

Wetlands in the National Wetlands Inventory

Impacts to NWI wetlands and other aquatic habitats may be subject to regulation under Section 404 of the Clean Water Act, or other State/Federal statutes.

For more information please contact the Regulatory Program of the local U.S. Army Corps of Engineers District.

THERE ARE NO KNOWN WETLANDS AT THIS LOCATION.

Data limitations

<https://ecos.fws.gov/ipac/location/5FPMJUOXFBEF5NXVEIDFEP6KRA/resources>

The Service's objective of mapping wetlands and deepwater habitats is to produce reconnaissance level information on the location, type and size of these resources. The maps are prepared from the analysis of high altitude imagery. Wetlands are identified based on vegetation, visible hydrology and geography. A margin of error is inherent in the use of imagery; thus, detailed on-the-ground inspection of any particular site may result in revision of the wetland boundaries or classification established through image analysis.

The accuracy of image interpretation depends on the quality of the imagery, the experience of the image analysts, the amount and quality of the collateral data and the amount of ground truth verification work conducted. Metadata should be consulted to determine the date of the source imagery used and any mapping problems.

Wetlands or other mapped features may have changed since the date of the imagery or field work. There may be occasional differences in polygon boundaries or classifications between the information depicted on the map and the actual conditions on site.

Data exclusions

Certain wetland habitats are excluded from the National mapping program because of the limitations of aerial imagery as the primary data source used to detect wetlands. These habitats include seagrasses or submerged aquatic vegetation that are found in the intertidal and subtidal zones of estuaries and nearshore coastal waters. Some deepwater reef communities (coral or tubercid worm reefs) have also been excluded from the inventory. These habitats, because of their depth, go undetected by aerial imagery.

Data precautions

Federal, state, and local regulatory agencies with jurisdiction over wetlands may define and describe wetlands in a different manner than that used in this inventory. There is no attempt, in either the design or products of this inventory, to define the limits of proprietary jurisdiction of any Federal, state, or local government or to establish the geographical scope of the regulatory programs of government agencies. Persons intending to engage in activities involving modifications within or adjacent to wetland areas should seek the advice of appropriate federal, state, or local agencies concerning specified agency regulatory programs and proprietary jurisdictions that may affect such activities.

Attachment C Species Observed in the Study Area

Table C-1. Plant Species Observed in the Study Area

Family	Scientific Name	Common Name
Native		
Asteraceae		
	<i>Baccharis pilularis</i>	Coyote brush
	<i>Centromadia fitchii</i>	Common spikeweed
	<i>Madia elegans</i>	Common madia
Fagaceae	<i>Quercus douglassii</i>	Blue oak
	<i>Quercus wislizenii</i>	Interior live oak
Hypericaceae	<i>Hypericum perforatum</i>	St. John's wort
Onagraceae	<i>Epilobium brachycarpum</i>	Annual fireweed
Rubiaceae	<i>Galium aparine</i>	Common bedstraw
Non-native		
Apiaceae	<i>Torilis arvensis</i>	Common hedge-parsley
Asteraceae	<i>Carduus pycnocephalis</i>	Italian thistle
	<i>Centaurea solstitialis</i>	Yellow star-thistle
	<i>Cichorium intybus</i>	Chicory
	<i>Holocarpha virgata</i>	Narrow tarplant
	<i>Lactuca serriola</i>	Prickly lettuce
Convolvulaceae	<i>Convolvulus arvensis</i>	Field bindweed
Euphorbiaceae	<i>Croton setiger</i>	dove weed
	<i>Triadica sebifera</i>	Chinese tallow tree
Fabaceae	<i>Trifolium hirtum</i>	Rose clover
	<i>Vicia sativa</i>	Common vetch
Geraniaceae	<i>Erodium botrys</i>	Broad leaf filaree
Plantaginaceae	<i>Plantago lanceolata</i>	English plantain
Poaceae	<i>Avenua fatua</i>	Wild oat
	<i>Aira caryophyllea</i>	Silver European hairgrass
	<i>Briza minor</i>	Little quakinggrass
	<i>Bromus diandrus</i>	Ripgut brome
	<i>Bromus hordeaceus</i>	Soft chess
	<i>Elymus caput-medusae</i>	Medusahead
	<i>Festuca perennis</i>	Italian rye grass
	<i>Hordeum marinum</i>	Barley
	<i>Vulpia microstachys</i>	Vulpia

Table C-2. Wildlife Species Observed in the Study Area

Family	Scientific Name	Common Name
Birds		
Columbidae	<i>Zenaidura macroura</i>	Mourning dove
Corvidae	<i>Apelocoma californica</i>	California scrub jay
Mimidae	<i>Mimus polyglottos</i>	Northern mockingbird
Mammals		
Sciuridae	<i>Otospermophilus beecheyi</i>	California ground squirrel

Attachment D
Potential for Regionally-Occurring Special-Status Species to Occur in the Project Site

Scientific Name/ Common Name ¹	Status ²	Habitat Requirements	Potential to Occur	Rationale
PLANTS				
<i>Allium jepsonii</i> Jepson's onion	--/1B.2	A perennial bulbiferous herb found on serpentinite or volcanic soils within chaparral, cismontane woodland, and lower montane coniferous forest from an elevation of 985 - 4330 feet. Blooms April to August (CNPS 2021).	Will not occur	There are no suitable soils or habitats on the project site to support this species.
<i>Calystegia stebbinsii</i> Stebbins' morning glory	FE/CE/1B.1	A perennial rhizomatous herb found in chaparral openings and cismontane woodland, sometimes on gabbroic soils or in seeps, from an elevation of 605 - 3,575 feet. Blooms April to July (CNPS 2021).	Will not occur	There are no suitable habitats on the project site to support this species.
<i>Carex xerophila</i> Chaparral sedge	--/1B.2	A perennial herb found on gabbroic or serpentinite soils within chaparral, cismontane woodland, or lower montane coniferous forest at an elevation of 1445 - 2525 feet. Blooms March to June (CNPS 2021).	Will not occur	There are no suitable soils or habitats on the project site to support this species.
<i>Ceanothus roderickii</i> Pine Hill ceanothus	FE/CR/1B.1	A perennial evergreen shrub found in chaparral and cismontane woodland on nutrient-deficient forms of gabbro-derived soils characterized by low concentrations of available K, P, S, Fe, and Zn, sometimes on gabbroic or serpentinite soils from 805 - 3,575 feet in elevation. Blooms April to June (CNPS 2021).	Will not occur	There are no suitable soils or habitats on the project site to support this species.
<i>Chlorogalum grandiflorum</i> Red Hills soaproot	--/1B.2	A perennial bulbiferous herb found on gabbroic or serpentinite soils within chaparral, cismontane woodland, and lower montane coniferous forest from an elevation of 805 - 5,545 feet. Blooms May to June (CNPS 2021).	Will not occur	There are no suitable soils or habitats on the project site to support this species.
<i>Crocanthemum suffrutescens</i> Bisbee Peak rush-rose	--/3.2	A perennial evergreen shrub found in chaparral on gabbroic or soils in burned or disturbed areas from an elevation of 245 - 2200 feet. Blooms April to August (CNPS 2021).	Will not occur	There are no suitable soils or habitats on the project site to support this species.

Attachment D
Potential for Regionally-Occurring Special-Status Species to Occur in the Project Site

Scientific Name/ Common Name ¹	Status ²	Habitat Requirements	Potential to Occur	Rationale
		2021)		
<i>Fremontodendron decumbens</i> Pine Hill flannelbush	FE/CR/1B .2	A perennial evergreen shrub found on gabbroic or serpentinite rocky soils within chaparral and cismontane woodland from an elevation of 1395 - 2495 feet. Blooms April to July (CNPS 2021).	Will not occur	There are no suitable soils or habitats on the project site to support this species.
<i>Galium californicum ssp. Sierra</i> El Dorado bedstraw	FE/CR/1B .2	A perennial herb found on gabbroic soil within chaparral, cismontane woodland, and lower montane coniferous forest from an elevation of 330 to 1,920 feet in elevation. Blooms May to June (CNPS 2021)	Will not occur	There are no suitable soils or habitats on the project site to support this species.
<i>Packera layneae</i> Layne's butterweed	FT/CR/1B. 2	A perennial herb found on serpentinite or gabbroic rocky soils within chaparral and cismontane woodland from 655 – 3,560 feet in elevation. Blooms April to August (CNPS 2021).	Will not occur	There are no suitable soils or habitats on the project site to support this species.
<i>Sagittaria sanfordii</i> Sanford's arrowhead	--/--/1B.2	An emergent perennial rhizomatous herb found in shallow freshwater marshes and swamps from 0 – 2,135 feet in elevation. Blooms May – October (sometimes November) (CNPS 2021).	Will not occur	There are no suitable habitats on the project site to support this species.
<i>Wyethia reticulata</i> El Dorado County mule ears	--/--/1B.2	A perennial herb found on clay or gabbroic soil within chaparral, cismontane woodland, and lower montane coniferous forest from an elevation of 605 – 2,065 feet. Blooms April to August (CNPS 2021).	Will not occur	There are no suitable soils or habitats on the project site to support this species.
ANIMALS				
Invertebrates				
<i>Branchinecta lynchi</i> vernal pool fairy shrimp	FT/--/--	Vernal pool fairy shrimp is found in vernal pools, seasonal wetlands, and other aquatic habitats such as ditches and artificial lakes and ponds. Vernal pools where this species is found range from small, clear, sandstone rock pools to large, turbid, alkaline, grassland valley floor	Will not occur	There are no suitable aquatic habitats on the project site to support this species.

Attachment D
Potential for Regionally-Occurring Special-Status Species to Occur in the Project Site

Scientific Name/ Common Name ¹	Status ²	Habitat Requirements	Potential to Occur	Rationale
		pools. Typical aquatic habitats where this species is found measure less than 0.05 acre, although this species has been collected from vernal pools and other water bodies exceeding 25 acres (USFWS 2005).		
<i>Desmocerus californicus dimorphus</i> valley elderberry longhorn beetle	FT/--/--	Valley elderberry longhorn beetle is endemic to elderberry shrubs (<i>Sambucus</i> spp.) and primarily occupies elderberry shrubs occurring in or within close proximity to riparian habitat. This species occurs throughout the Sacramento and San Joaquin Valleys from Redding to Fresno County typically below 152 meters in elevation (USFWS 2017a).	Will not occur	There are no elderberry shrubs on the project site.
<i>Lepidurus packardii</i> vernal pool tadpole shrimp	FE/--/--	Vernal pool tadpole shrimp is found in vernal pools ranging from 54 square feet to 89 acres, containing clear- to highly-turbid water. This species is also found in other fishless water bodies such as ponds, ditches and seasonal wetlands that fill up in the winter/spring and dry up by late summer. Its known range is within the Central Valley of California and in the San Francisco Bay area (USFWS 2005).	Will not occur	There are no suitable aquatic habitats on the project site to support this species.
Fishes				
<i>Hypomesus transpacificus</i> delta smelt	FT/--/SSC	Delta smelt is found in the upper Sacramento-San Joaquin Estuary of California where it mainly inhabits the freshwater-saltwater mixing zone, except during its spawning season, when it migrates upstream to fresh water following winter "first flush" flow events (around March to May) (Moyle 2002).	Will not occur	There are no suitable aquatic habitats on the project site to support this species.

Attachment D
Potential for Regionally-Occurring Special-Status Species to Occur in the Project Site

Scientific Name/ Common Name ¹	Status ²	Habitat Requirements	Potential to Occur	Rationale
Amphibians				
<i>Ambystoma californiense</i> California tiger salamander (central Valley DPS)	FT/ST/--	California tiger salamanders are generally restricted to vernal pools and seasonal ponds, including many constructed stock ponds, in grassland and oak savannah plant communities from sea level to about 1,500 feet in central California. This species breeds in suitable aquatic habitats but spends the majority of its life in upland areas in the vicinity of suitable breeding ponds, where it inhabits rodent burrows (USFWS 2017b).	Will not occur	There are no suitable aquatic breeding habitats on or in close proximity to the project site to support this species.
<i>Rana boylei</i> Foothill yellow-legged frog	--/SE/SSC	Frequents rocky streams and rivers with rocky substrate and open, sunny banks, in forests, chaparral, and woodlands. Sometimes found in isolated pools, vegetated backwaters, and deep, shaded, spring-fed pools (California Herps 2021).	Will not occur	There are no suitable aquatic habitats on the project site to support this species.
<i>Rana draytonii</i> California red-legged frog	FT/--/SSC	California red-legged frogs require dense, shrubby or emergent riparian vegetation closely associated with deep (greater than 2 1/3-foot deep) still or slow-moving water to support breeding. During periods of aestivation, California red-legged frogs use small mammal burrows and moist leaf litter in proximity to suitable breeding habitat and can migrate up to 1.2 miles overland to find suitable breeding habitat or upland refugia (USFWS 2002).	Will not occur	There are no suitable aquatic habitats on the project site to support this species.
<i>Spea hammondi</i> western spadefoot	--/--/SSC	Western spadefoot breeds in vernal pools and seasonal ponds or slow portions of streams in grasslands and woodlands and the adults spend most of their time in underground burrows in grasslands surrounding the aquatic breeding habitat (Jennings and Hayes 1994).	Will not occur	There are no suitable aquatic habitats on the project site to support this species.

Attachment D
Potential for Regionally-Occurring Special-Status Species to Occur in the Project Site

Scientific Name/ Common Name ¹	Status ²	Habitat Requirements	Potential to Occur	Rationale
Reptiles				
<i>Emys marmorata</i> western pond turtle	--/--/SSC	This species inhabits a variety of aquatic habitats including slow-moving water with dense submerged vegetation, ponds, and fast moving streams. Requires abundant basking sites, gently sloping banks, and dry clay or silt soils in nearby uplands. Turtles will lay eggs up to 0.25-mile from water, but typically go no more than 600 feet (Jennings and Hayes 1994).	Will not occur	There are no suitable aquatic habitats on the project site to support this species.
<i>Phrynosoma blainvillii</i> Coast horned lizard	--/--/SSC	This species inhabits open areas of sandy soil and low vegetation in valleys, foothills and semiarid mountains. Found in grasslands, coniferous forests, woodlands, and chaparral, with open areas and patches of loose soil. Often found in lowlands along sandy washes with scattered shrubs and along dirt roads. Often found near ant hills feeding on ants (California Herps 2021).	Will not occur	There is no suitable habitat on the project site to support this species. The project site is surrounded by development and roadways.
<i>Thamnophis gigas</i> giant garter snake	FT/ST/--	Giant garter snake inhabits agricultural wetlands and other waterways such as irrigation and drainage canals, sloughs, ponds, small lakes, low gradient streams, and adjacent uplands in the San Joaquin and Sacramento Valley floors. This species requires adequate water during its active season (early spring through mid-fall) to provide food and cover, emergent, herbaceous wetland vegetation for foraging and cover, grassy banks and openings in waterside vegetation for basking, and higher elevation uplands for cover and refuge from flood waters during its dormant season (winter). Giant garter snake seek refuge in ground squirrel	Will not occur	The project site is outside of this species geographic range and lacks suitable aquatic habitat.

Attachment D
Potential for Regionally-Occurring Special-Status Species to Occur in the Project Site

Scientific Name/ Common Name ¹	Status ²	Habitat Requirements	Potential to Occur	Rationale
		burrows and other small mammal burrows as well as other crevices such as openings in riprap along banks with sunny exposure that are above the typical limits of flooding during the inactive season (USFWS 2017c).		
Birds				
<i>Agelaius tricolor</i> tricolored blackbird	--/ST/SSC	Tricolored blackbird nests and seeks cover in emergent wetland vegetation and thorny vegetation such as Himalayan blackberry (<i>Rubus armeniacus</i>) as well as cattails (<i>Typha</i> spp.), willows (<i>Salix</i> spp.), and tules. The nesting habitat must be large enough to support a minimum colony of 50 pairs as they are a highly colonial species. Forages on ground in croplands, grassy fields, flooded land, and edges of ponds for insects (Shuford and Gardali 2008).	Will not occur	There is no suitable nesting or foraging habitat on the project site for this species.
<i>Aquila chrysaetos</i> golden eagle	--/--/FP	Golden eagles typically occur in rolling foothills, mountain areas, deserts and other open habitats and nest on cliff ledges or large trees in open areas in canyons. This species will occasionally use other tall structures for nesting, such as electrical transmission towers. Golden eagles prey primarily on rodents, carrion, birds, reptiles and occasionally small livestock (Zeiner et al. 1990).	Will not occur	There is no suitable nesting or foraging habitat on the project site for this species and the project site is a small parcel surrounded by development and roadways.
<i>Ardea alba</i> great egret	--/--/--	This species inhabits freshwater, brackish, and marine wetlands. Rookeries are located on lakes, ponds, marshes, estuaries, impoundments, and islands. Great egrets forage in a variety of aquatic and terrestrial habitats including marshes, swamps, streams, rivers, ponds, lakes, impoundments, lagoons, tidal flats, canals,	Will not occur	There is no suitable nesting or foraging habitat for this species in the project site.

Attachment D
Potential for Regionally-Occurring Special-Status Species to Occur in the Project Site

Scientific Name/ Common Name ¹	Status ²	Habitat Requirements	Potential to Occur	Rationale
		ditches, fish-rearing ponds, flooded farm fields, and grain fields (Cornell Lab 2021).		
<i>Ardea herodias</i> Great blue heron	--/--/--	Great Blue Herons live in both freshwater and saltwater habitats. This species forages in grasslands and agricultural fields. Breeding colonies are typically located within 2 to 4 miles of feeding areas, often in isolated swamps or on islands, and near lakes and ponds bordered by forests. This species typically eats frogs and small mammals (Cornell Lab 2021).	Will not occur	There is no suitable nesting or foraging habitat for this species in the project site.
<i>Athene cunicularia</i> burrowing owl	--/--/SSC	Burrowing owl nests and forages in grasslands, agricultural fields, and disturbed places where burrowing mammals are abundant. This species does not dig its own burrows, but nests in abandoned burrows dug by fossorial mammals, especially those of California ground squirrel (<i>Otospermophilus beecheyi</i> ; CDFW 2012). This species also nests in artificial structures such as small culverts and pipes.	Will not occur	The project site is too small to provide suitable habitat for this species and is surrounded by development and roadways. No sign of burrowing owl was observed on the project site during the biological survey.
<i>Elanus leucurus</i> white-tailed kite	--/--/FP	White-tailed kite typically inhabit open habitats such as rolling foothills and valley margins with scattered oaks, as well as river bottomlands or marshes next to deciduous woodland. They typically nest in isolated, dense-topped trees in open areas and forages in a variety of habitats adjacent to the nesting habitat including grassland, marshes, and agricultural fields (Zeiner <i>et al.</i> 1990).	Will not occur	There is no suitable nesting or foraging habitat for this species in the project site.
<i>Haliaeetus leucocephalus</i> Bald eagle	FD/SE/FP	Bald eagles require a good food base, perching areas, and nesting sites. Their habitat includes estuaries, large lakes,	Will not occur	There is no suitable nesting or foraging habitat for this species in the project site.

Attachment D
Potential for Regionally-Occurring Special-Status Species to Occur in the Project Site

Scientific Name/ Common Name ¹	Status ²	Habitat Requirements	Potential to Occur	Rationale
		reservoirs, rivers, and some seacoasts. Bald eagles generally nest near coastlines, rivers, and large lakes where there is an adequate food supply. They nest in mature or old-growth trees, snags (dead trees), cliffs, and rock promontories. In treeless regions, they may also nest in cliffs or on the ground. Recently, and with increasing frequency, bald eagles are nesting on artificial structures such as power poles and communication towers, and away from large water bodies. In forested areas, bald eagles often select the tallest trees with limbs strong enough to support a nest that can weigh 1,000 pounds or more. Nest sites typically include at least one perch with a clear view of the water, where they forage (USFWS 2019).		
<i>Laterallus jamaicensis</i> California black rail	--/ST/FP	California black rail inhabits brackish marsh, primarily in the upper marsh zone dominated by alkali heath (<i>Frankenia salina</i>), cattail, and rush (<i>Juncus</i>); prefers lower salinity environments. This species forages on the ground, under cover of dense vegetation (USFWS 2013).	Will not occur	There is no suitable aquatic habitat for this species in the project site.
<i>Riparia riparia</i> bank swallow	--/ST/--	Bank swallow primarily inhabits riparian and other lowland habitats west of the deserts during the spring-fall period. In summer, this species is restricted to riparian, lacustrine, and coastal areas with vertical banks, bluffs, and cliffs with fine-textured or sandy soils where it digs holes for nesting. In California, bank swallow primarily nests from Siskiyou, Shasta and Lassen Counties south along the Sacramento River to Yolo County.	Will not occur	There is no suitable nesting habitat for this species in the project site.

Attachment D

Potential for Regionally-Occurring Special-Status Species to Occur in the Project Site

Scientific Name/ Common Name ¹	Status ²	Habitat Requirements	Potential to Occur	Rationale
Mammals				
<i>Pekania pennanti</i> Fisher	--/--/SSC	Fishers are associated with areas of high cover and structural complexity in large tracts of mature and old-growth forests. Other site characteristics that can be important include presence of nearby water, slope, elevation, and snow characteristics (USFS 2021).	Will not occur	There is no suitable habitat for this species in the project site.

- ¹ Sensitive species reported in CNDDDB or CNPS on the "Clarksville and Shingle Springs, CA" USGS 7.5 Minute topographic quads, or in the USFWS list for the project site.
- ² Status is as follows: Federal (ESA) listing/State (CESA) listing/other CDFW status or CRPR. F = Federal; S = State of California; E = Endangered; T = Threatened; C = Candidate; FP=Fully Protected; SSC=Species of Special Concern; WL=Watch List.
- ³ Status in the Project site is assessed as follows. **Will Not Occur:** Species is either sessile (*i.e.* plants) or so limited to a particular habitat that it cannot disperse on its own and/or habitat suitable for its establishment and survival does not occur on the project site; **Not Expected:** Species moves freely and might disperse through or across the project site, but suitable habitat for residence or breeding does not occur on the project site, potential for an individual of the species to disperse through or forage in the site cannot be excluded with 100% certainty; **Presumed Absent:** Habitat suitable for residence and breeding occurs on the project site; however, focused surveys conducted for the current project were negative; **May Occur:** Species was not observed on the site and breeding habitat is not present but the species has the potential to utilize the site for dispersal, **High:** Habitat suitable for residence and breeding occurs on the project site and the species has been recorded recently on or near the project site, but was not observed during surveys for the current project; **Present:** The species was observed during biological surveys for the current project and is assumed to occupy the project site or utilize the project site during some portion of its life cycle.
- CRPR = California Rare Plant Rank: 1B – rare, threatened, or endangered in California and elsewhere; 2B – rare, threatened, or endangered in California but more common elsewhere. Extension codes: .1 – seriously endangered; .2 – moderately endangered.

7021 OCT 22 AM 8:11

RECEIVED
PLANNING DEPARTMENT

California
Historical
Resources
Information
System

NORTH CENTRAL
INFORMATION
CENTER



AMADOR
EL DORADO
NEVADA
PLACER
SACRAMENTO
YUBA

California State University, Sacramento
6000 J Street, Folsom Hall, Suite 2042
Sacramento, California 95819-6100
phone: (916) 278-6217
fax: (916) 278-5162
email: ncic@csus.edu

8/23/2021

NCIC File No.: ELD-21-66

APN: 082-411-004

SEC. 4/9/T9N/R9E

Ron Personius
Lebeck Engineering, Inc.
3430 Robin Lane, Bld. #2
Cameron Park, CA 95682

Records Search Results for

2545 Greenwood Lane, Cameron Park, CA 95682 (APN: 082-411-004) / Job #20-133

Ron Personius:

Per your request received by our office on 8/23/2021, a complete records search was conducted by searching California Historic Resources Information System (CHRIS) maps for cultural resource site records and survey reports in El Dorado County within a 1/4-mile radius of the proposed project area.

Review of this information indicates that the proposed project area contains **zero (0)** recorded indigenous-period/ethnographic-period resource(s) and **zero (0)** recorded historic-period cultural resource(s). Additionally, **zero (0)** cultural resources study report(s) on file at this office cover(s) a portion of the proposed project area.

Outside the proposed project area, but within the 1/4-mile radius, the broader search area contains **zero (0)** recorded indigenous-period/ethnographic-period resource(s) and **one (1)** recorded historic-period cultural resource(s): P-09-5552 (19th century rock wall). Additionally, **thirteen (13)** cultural resources study report(s) on file at this office cover(s) a portion of the broader search area: 2593, 3668, 3726, 3746, 4559, 6888, 7470, 8990, 9199, 11191, 11319, 12865, and 12877.

In this part of El Dorado County, archaeologists locate indigenous-period/ethnographic-period habitation sites "along streams or on ridges or knolls, especially those with southern exposure" (Moratto 1984: 290). This region is known as the ethnographic-period territory of the Nisenan, also called the Southern Maidu. The Nisenan maintained permanent settlements along major rivers in the Sacramento Valley and foothills; they also periodically traveled to higher elevations (Wilson and Towne 1978: 387-389). The proposed project search area is situated in the Sierra Nevada foothills about 1/4-mile west of an intermittent stream. Modern development surrounds the property and previous adjacent survey coverage did not identify indigenous-period/ethnographic-period cultural resources in the vicinity. Given the extent of known cultural resources and the environmental setting, there is **low potential** for locating indigenous-period/ethnographic-period cultural resources in the immediate vicinity of the proposed project area.

The 1866 GLO plat of T9N, R9E shows evidence of nineteenth-century Sacramento and Placerville Road (now Country Club Drive) and houses and associated features in the vicinity. The 1953 Clarksville 7.5'

Z21-0012/PD21-0003/TM21-0001

scanned 10-22-2021 KKB

USGS topographical map shows evidence of the current alignment of Country Club Drive about 0.15 miles north. Modern development surrounds the property and previous adjacent survey coverage did not identify historic-period cultural resources in the immediate vicinity. Given the extent of known cultural resources and patterns of local history, there is **low potential** for locating historic-period cultural resources in the immediate vicinity of the proposed project area.

LITERATURE REFERENCED DURING SEARCH:

In addition to the official records and maps for sites and studies in El Dorado County, the following inventories and references were also reviewed: National Register of Historic Places and California Register of Historical Resources - Listed properties; California Inventory of Historic Resources (1976); California State Historical Landmarks; California Points of Historical Interest; Office of Historic Preservation Built Environment Resources Directory (2020); Office of Historic Preservation Archaeological Determinations of Eligibility (2012); Caltrans State and Local Bridge Surveys; Gold Districts of California (Clark 1970); California Gold Camps (Gudde 1975); California Place Names (Gudde 1969); Historic Spots in California (Hoover et al. 1966 [1990]); Trail of the First Wagons Over the Sierra Nevada (Graydon 1986); California Archaeology (Moratto 1984); and the Smithsonian Institution's Handbook of North American Indians, Volume 8, California (Wilson and Towne 1978).

SENSITIVITY STATEMENT:

- 1) With respect to cultural resources, it appears that the proposed project area **is not sensitive**.
- 2) Should the lead agency/authority require a cultural resources survey, a list of qualified local cultural resources consultants can be found at <http://chrisinfo.org>. Please forward copies of any resulting reports and resource records from this project to the North Central Information Center (NCIC) as soon as possible. The lead agency/authority and cultural resources consultant should coordinate sending documentation to NCIC. Please note that local planning agencies rarely, if ever, send reports and resource records to our office. Digital materials are preferred and can be sent to our office through our file transfer system or on a CD by mail via USPS to the address on the top of the first page. Hard copies may also be mailed.
- 3) If cultural resources are encountered during the project, avoid altering the materials and their context until a qualified cultural resources professional has evaluated the project area. Project personnel should not collect cultural resources. Indigenous-period/ethnographic-period resources include: chert or obsidian flakes, projectile points, and other flaked-stone artifacts; mortars, grinding slicks, pestles, and other groundstone tools; and dark friable soil containing shell and bone dietary debris, heat-affected rock, or human burials. Historic-period resources include: stone or adobe foundations or walls; structures and remains with square nails; mine shafts, tailings, or ditches/flumes; and refuse deposits or bottle dumps, often located in old wells or privies.
- 4) Identified cultural resources should be recorded on DPR 523 (A-L) historic resource recordation forms, available at https://ohp.parks.ca.gov/?page_id=28351.
- 5) Review for possible historic-period cultural resources has included only those sources listed in the referenced literature and should not be considered comprehensive. The Office of Historic Preservation has determined that buildings, structures, and objects 45 years or older may be of historical value. If the area of potential effect contains such properties not noted in our research, they should be assessed by an architectural historian before commencement of project activities.

Due to processing delays and other factors, it is possible that not all of the historical resource reports and resource records that have been submitted to the Office of Historic Preservation are available via

this records search. Additional information may be available through the federal, state, and local agencies that produced or paid for historical resource management work in the search area. Additionally, Native American tribes have historical resource information not in the California Historical Resources Information System (CHRIS) Inventory, and you should contact the California Native American Heritage Commission for information on local/regional tribal contacts.

The California Office of Historic Preservation (OHP) contracts with the California Historical Resources Information System's (CHRIS) regional Information Centers (ICs) to maintain information in the CHRIS inventory and make it available to local, state, and federal agencies, cultural resource professionals, Native American tribes, researchers, and the public. Recommendations made by IC coordinators or their staff regarding the interpretation and application of this information are advisory only. Such recommendations do not necessarily represent the evaluation or opinion of the State Historic Preservation Officer in carrying out the OHP's regulatory authority under federal and state law.

Thank you for using our services. Please contact North Central Information Center at ncic@csus.edu or (916) 278-6217 if you have any questions about this records search.

Sincerely,

Paul Rendes, Coordinator
North Central Information Center

**GEOTECHNICAL ENGINEERING STUDY
FOR
GREENWOOD ESTATES
2545 Greenwood Lane
Cameron Park, California**

Project No. E22014.000
February 2022

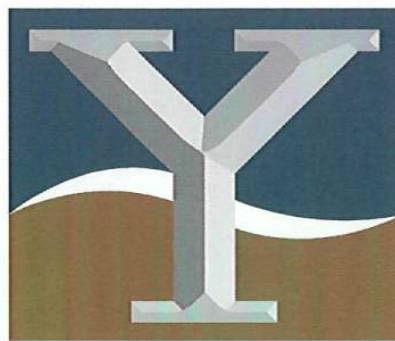

YOUNGDAHL
ESTABLISHED 1984



1234 Glenhaven Court, El Dorado Hills, CA 95762
4300 Anthony Court, Unit D, Rocklin, CA 95677
ph 916.933.0633 fx 916.933.6482
www.youngdahl.net

Cameron Glen Estates, LLC.
2216 Via Subria
Vista, California 92084-2834
ATTN: Mr. Joe Jaoudi

Project No. E22014.000
9 March 2022

Subject: **GREENWOOD ESTATES**
2545 Greenwood Lane, Cameron Park, California
GEOTECHNICAL ENGINEERING STUDY

References: 1. Contract and Proposal for Greenwood Estates, prepared by Youngdahl Consulting Group, dated 7 December 2021.
2. Tentative Map/Rezone/Planned Development for Greenwood Estates, prepared by TM, dated 16 November 2021.

Dear Mr. Jaoudi:

In accordance with your authorization, Youngdahl Consulting Group, Inc. has prepared this geotechnical engineering study for the project site located at 2545 Greenwood Lane in Cameron Park, California. The purpose of this study was to prepare a site-specific geotechnical report based on new information that can be incorporated into design of the proposed site. To complete this task, our firm completed a limited subsurface exploration, reviewed the referenced documents, and prepared this report in accordance with the Reference 1 contract.

Based upon our observations, the geotechnical aspects of the site appear to be suitable for support of the proposed structures provided the recommendations presented in this report are incorporated into the design and construction. Geotechnical conditions associated with site development are anticipated to include processing existing grades for preparation to receive engineered fills, the placement of engineered fills, improvement for drainage controls, and the construction of foundations.

Due to the non-uniform nature of soils, other geotechnical issues may become more apparent during grading operations which are not listed above. The descriptions, findings, conclusions, and recommendations provided in this report are formulated as a whole; specific conclusions or recommendations should not be derived or used out of context. Please review the limitations and uniformity of conditions section of this report.

This report has been prepared for the exclusive use of the addressee of this report and their consultants, for specific application to this project, in accordance with generally accepted geotechnical engineering practice. Should you have any questions or require additional information, please contact our office at your convenience.

Very truly yours,
Youngdahl Consulting Group, Inc.

Mitchell Perigo
Staff Geologist

Distribution: PDF to Client

Reviewed by:

Martha A. McDonnell, P.E.
Associate Engineer



3-9-22

TABLE OF CONTENTS

1.0	INTRODUCTION.....	1
	Project Understanding.....	1
	Purpose and Scope.....	1
2.0	SITE CONDITIONS.....	1
	Surface Observations.....	1
	Subsurface Conditions.....	2
	Groundwater Conditions.....	2
3.0	GEOTECHNICAL SOIL CHARACTERISTICS.....	2
	Laboratory Testing.....	2
	Soil Expansion Potential.....	3
	Soil Corrosivity.....	3
4.0	GEOLOGY AND SEISMICITY.....	3
	Geologic Conditions.....	3
	Naturally Occurring Asbestos.....	4
	Seismicity.....	5
	Earthquake Induced Liquefaction, Settlement, and Surface Rupture Potential.....	6
	Static and Seismically Induced Slope Instability.....	6
5.0	DISCUSSION AND CONCLUSIONS.....	6
	Geotechnical Considerations for Development.....	7
6.0	SITE GRADING AND EARTHWORK IMPROVEMENTS.....	7
	Excavation Characteristics.....	7
	Soil Moisture Considerations.....	8
	Site Preparation.....	8
	Engineered Fill Criteria.....	9
	Slope Configuration and Grading.....	11
7.0	DESIGN RECOMMENDATIONS.....	11
	Shallow Conventional Foundations.....	11
	Slab-on-Grade Construction.....	13
	Exterior Flatwork.....	14
	Retaining Walls.....	14
	Asphalt Concrete Pavement Design.....	16
	Portland Cement Concrete Pavement Design.....	17
	Drainage.....	18
8.0	DESIGN REVIEW AND CONSTRUCTION MONITORING.....	20
	Plan Review.....	20
	Construction Monitoring.....	21
	Post Construction Drainage Monitoring.....	21
9.0	LIMITATIONS AND UNIFORMITY OF CONDITIONS.....	21
	APPENDIX A.....	24
	Introduction.....	25
	Vicinity Map (Figure A-1).....	26
	Site Map (Figure A-2).....	27
	Logs of Exploratory Test Pits (Figures A-3 through A-6).....	28
	Soil Classification Chart and Log Explanation (Figure A-7).....	32



APPENDIX B	33
Direct Shear Test (Figure B-1).....	34
Modified Proctor Test (Figure B-2).....	35
R-Value Test (Figure B-3).....	36
Corrosivity Tests.....	37
APPENDIX C	38
Keyway and Bench with Drain (Figure C-1).....	39
Site Wall Drainage (Figure C-2).....	40
APPENDIX D	41
Chain of Custody.....	42
Results of Laboratory Testing for NOA.....	43

GEOTECHNICAL ENGINEERING STUDY FOR GREENWOOD ESTATES

1.0 INTRODUCTION

This report presents the results of our geotechnical engineering study performed for the proposed residential development planned to be constructed at 2545 Greenwood Lane in Cameron Park, California. The vicinity map provided on Figure A-1, Appendix A shows the approximate project location.

Project Understanding

We understand that development of the project will include construction of 10 duplex style residences at 2545 Greenwood Lane in Cameron Park, California. The residences will be two-stories of wood frame construction and supported by conventional shallow foundations with concrete slab on grade floors. Additional site improvements will include concrete and asphalt flatwork and pavements for parking and walkways, and driveway access from Greenwood Lane.

If studies or plans pertaining to the site exist and are not cited as a reference in this report, we should be afforded the opportunity to review and modify our conclusions and recommendations as necessary.

Purpose and Scope

Youngdahl Consulting Group, Inc. has prepared this report to provide geotechnical engineering recommendations and considerations for incorporation into the design and development of the site. The following scope of services were developed and performed for preparation of this report:

- A review of geotechnical and geologic data available to us at the time of our study;
- Performance of a field study consisting of a site reconnaissance and shallow subsurface explorations to observe and characterize the subsurface conditions;
- Laboratory testing on representative samples collected during our field study;
- Evaluation of the data and information obtained from our field study, laboratory testing, and literature review for geotechnical conditions;
- Development of the following geotechnical recommendations and considerations regarding earthwork construction including, site preparation and grading, engineered fill criteria, seasonal moisture conditions, compaction equipment, excavation characteristics, slope configuration and grading, and drainage;
- Development of geotechnical design criteria for code-based seismicity, foundations, slabs on grade, and retaining walls;
- Preparation of this report summarizing our findings, conclusions, and recommendations regarding the above-described information.

2.0 SITE CONDITIONS

The following section describes our findings regarding the site conditions that we observed during our site reconnaissance and subsequent subsurface explorations.

Surface Observations

The project site consists of an undeveloped lot situated at the west side of Greenwood Lane in Cameron Park, California. The project site is bounded by Greenwood Lane to the east, developed property to the south, undeveloped property to the north, and by baseball fields to the west. The lot generally slopes up from Greenwood Lane at a general gradient of approximately 7H:1V (Horizontal:Vertical). Vegetation consisted of a few oak trees and seasonal grasses. Additionally, surface rock outcroppings were observed scattered throughout the project site.



Subsurface Conditions

Our field study included a site reconnaissance by a representative of our firm followed by a subsurface exploration program conducted on 17 January 2022. The exploration program included the excavation of 4 exploratory test pits conducted by our representative at the marked locations (Appendix A-2).

Subsurface soil conditions were consistent at the locations evaluated and included sandy silts and sandy clays underlain by weathered metavolcanic bedrock. The upper soil layers were generally observed to be medium stiff sandy silts to depths up to 2 feet. Thin layers of sandy clay were encountered below the sandy silt on the west side of the property. The weathered metavolcanic bedrock was encountered at 2 to 2½ feet below the ground surface. The bedrock is completely to moderately weathered and moderately soft to hard with close jointing. Refusal with a CAT 303.5E mini excavator was encountered within a couple feet into bedrock. For more details on subsurface conditions Appendix A Figures A-3 to A-6.

Groundwater Conditions

A permanent groundwater table was not encountered at the project site and is expected to be relatively deep with no impact to the development of the site. However, due to the shallow depth and low permeability of the underlying rock, perched water is common to the area and could be encountered during grading operations. We did not observe perched water during our recent subsurface exploration program. The presence of perched water can vary because of many factors such as, the proximity to rock, topographic elevations, and the presence of utility trenches. Based on our experience in the area, water may be perched on the bedrock horizon found beneath the site and could vary through the year with higher concentrations during or following precipitation.

3.0 GEOTECHNICAL SOIL CHARACTERISTICS

The geotechnical soil characteristics presented in this section of the report are based on laboratory testing from previous studies and observation of samples collected from subsurface soils.

Laboratory Testing

Laboratory testing of the collected samples was directed towards determining the physical and engineering properties of the soil underlying the site. A description of the tests performed for this project and the associated test results are presented in Appendix B. In summary, the following tests were performed for the preparation of this report:

Table 2: Laboratory Tests

Laboratory Test	Test Standard	Summary of Results	
Direct Shear	ASTM D3080	Composite	$\Phi = 33.5^\circ$, $c = 0$ psf (90%RC)
R-Value	ASTM D4318	Composite	R = 28 at 300 psi
Maximum Dry Density	ASTM D1557	Composite	DD = 119.9 pcf, MC = 11.9 %
Corrosivity Suite	CA DOT Tests 417, 422 and 643	See Soil Corrosivity Section	



Soil Expansion Potential

Occasional pockets of plastic materials (clay soils) were encountered; however, the materials encountered in our explorations were generally non-plastic (rock, sand, and non-plastic silt). The non-plastic materials are generally considered to be non-expansive. Due to the limited presence of plastic materials observed, we do not anticipate that special design considerations for expansive soils will be required for the design or construction of the proposed improvements provided the plastic materials are adequately blended with the non-plastic site soils prior to use as engineered fill during the site grading procedures. Depending on the proposed grading plans and cuts or fills in the areas where clay was encountered, some focus excavations of the clay may be required. If necessary, recommendations can be made based on our observations at the time of construction should greater quantities of expansive soils be encountered at the project site which were not encountered during our study.

Soil Corrosivity

A corrosivity testing suite consisting of soil pH, resistivity, sulfate, and chloride content tests were performed on selected soil samples collected during our site exploration. We are not corrosion specialists and recommend that the results be evaluated by a qualified corrosion expert. The laboratory test results (provided by Sunland Analytical, Inc.) are provided in Appendix B and are summarized in Table 2, below.

Table 2: Corrosivity Summary

Location	Depth (ft)	Soil pH	Minimum Resistivity ohm-cm (x1000)	Chloride (ppm)	Sulfate (ppm)	Caltrans Environment	ACI Environment
TP-1,2	0-2	6.19	3.22	1.7	9.3	Non-Corrosive	S0 (Not a Concern)
TP-3,4	0-2	5.98	4.56	2.7	6.0	Non-Corrosive	S0 (Not a Concern)

According to Caltrans Corrosion Guidelines Version 3.0, March 2018, the test results appear to indicate a non-corrosive environment for steel used in mechanically stabilized earth elements. According to the 2019 California Building Code Section 1904.1 and ACI 318-14 Table 19.3.1.1, the test results indicate the onsite soils have a negligible potential for sulfide attack of concrete. Accordingly, Type I/II Portland cement is appropriate for use in concrete construction. A certified corrosion engineer should be consulted to review the above tests and site conditions in order to develop specific mitigation recommendations if metallic pipes or structural elements are designed to be in contact with or buried in soil.

4.0 GEOLOGY AND SEISMICITY

The geologic portion of this report includes a review of geologic data pertinent to the site based on an interpretation of our observations of the surface exposures and our observations in our exploratory test pits.

Geologic Conditions

The geologic portion of this report included a review of geologic data pertinent to the site and an interpretation of our observations of the surface exposures and our observations in our exploratory test pits excavated during the field study.



The site is situated in the western foothills region of the Sierra Nevada geomorphic province in El Dorado County, California. This province is dominated by long belts of metamorphic rock formed by ancient subduction and related volcanism, continental accretion and uplift during the Jurassic and Cretaceous ages (CDMG, 1984, OFR 84-50).

Naturally Occurring Asbestos

Asbestos is classified by the EPA as a known human carcinogen. Naturally occurring asbestos (NOA) has been identified as a potential health hazard. The California Geological Survey published a map in 2018 (Brujin; August 2018: Open File Report 2000-02, 2018 Update) that qualitatively indicates the likelihood for NOA in western El Dorado County. The project site is identified as being in a NOA review zone based on the published map, triggering some specific County requirements and additional recommendations.

El Dorado County Air Quality Management District Rule 223-2 regulates grading in asbestos areas. Rule 223-2 requires that finished grade surface asbestos concentrations be below 0.25% as measured by California Air Resources Board Test Method 435 (ARB TM 435); potentially requiring testing and management for asbestos during grading followed by the testing of finished grades for asbestos. All export soil/rock is required to be tested along with the completion of special documentation to accompany the export. Disclosure is required for properties containing asbestos.

Our firm sampled and tested one sample for NOA in order to provide a better understanding on the levels of NOA that may be present within the on-site soils and whether fill may need to be imported to cap the building pad. Testing indicated that NOA was not detected within the sample. We anticipate that the materials on-site may be used to grade the site to its proposed finish grade condition; however, the following procedures and comments are still applicable to the development of the site. A copy of the chain of custody and a summary of the laboratory test results is provided in Appendix D.

Asbestos Dust Mitigation Plan

In El Dorado County, all grading projects in NOA review areas disturbing 20 cubic yards or more of soil and/or rock, are required to follow Rule 223-2 by the El Dorado County Air Quality Management District (Air District). This includes the completion of an Asbestos Dust Mitigation Plan application, that when approved, becomes the Asbestos Dust Mitigation Plan. For projects subject to an Asbestos Dust Mitigation Plan, special track out control measures are required and any track out must be cleaned up immediately. Fugitive dust cannot travel more than 25 feet from a source and cannot cross a property line. Blasting is subject to special dust control requirements. Site stabilization is required to prevent and control wind driven dust. There are special record keeping and retention requirements. Finished grade testing for asbestos may be required by the Air District. If sensitive receptors are close by (i.e., schools or residences), air monitoring for NOA may be required by the Air District. Violations can result in fines.

Management During Grading

Soils with high concentrations of asbestos cannot be used in any finished surface exposed to the air and should be avoided in shallow portions of fills. Ideally, NOA should be placed in deep fills below deep future excavation (i.e., pools) and below high maintenance shallow utilities such as sprinkler systems (at least 2 feet). This may require planning and sequencing grading to place soils with higher concentrations of NOA into deep fills; the placement locations and depths must be documented. Soils without or with only trace levels of NOA might be stockpiled for use at finished grades. Rock crushing of materials containing asbestos is prohibited. A geologist's direct observation may be necessary during grading to identify materials likely to contain NOA. The collection of soil/rock samples for analyses for NOA might become necessary during grading. Finished lot testing for NOA will likely be required.



All soil exported from a project in an Asbestos Review Zone is required to be tested. This typically requires the preparation of a work plan to be submitted to and approved by the Air Quality Management District. At least one sample per 1,000 tons is required. Soil containing trace levels of asbestos (less than 0.25 percent) is subject to asbestos dust mitigation plan requirements when exported to another site in El Dorado County. Soil with 0.25 to less than 1.0 percent asbestos cannot be used for surfacing in California. Soils containing 1.0 percent or more asbestos are considered to be asbestos containing material and, if disposed of off-site, must be managed as a hazardous waste with transport subject to special California Department of Transportation Regulations; however, such soils can be used in El Dorado County to construct engineered fills in conformance with Rule 223-2. All export of soil from asbestos review areas requires special documentation to be provided to the recipient of such soils.

Discovery Outside of Asbestos Review Areas

When asbestos, serpentine, or ultramafic rock is discovered outside of an Asbestos Review Zone, or in an area that was able to obtain an exemption from filing and Asbestos Dust Mitigation Plan, the owner or operator must notify the Air District no later than the next business day.

Seismicity

Our evaluation of seismicity for the project site included reviewing existing fault maps and obtaining seismic design parameters from the USGS online calculators and databases. For the purpose of this study, we used a latitude and longitude of 38.848527, -121.236166 to identify the project site.

Alquist-Priolo Regulatory Faults

Based upon the records currently available from the California Department of Conservation, the project site is not located within an Alquist-Priolo Regulatory Review Zone and there are no known faults located at the subject site. We do not anticipate special design or construction requirements for faulting at this project site.

Code Based Seismic Criteria

Based upon the subsurface conditions encountered during our study and our experience in the area, the site should be classified as Site Class C. The structural engineer should review the conditions of the exception and the final choice of design parameters remains the purview of the project structural engineer.

Table 2: Seismic Design Parameters*

	Reference	Seismic Parameter	Recommended Value
ASCE 7-16	Table 20.3-1	Site Class	C
	Figure 22-7	Maximum Considered Earthquake Geometric Mean (MCEC) PGA	0.173g
	Table 11.8-1	Site Coefficient F_{PGA}	1.227
	Equation 11.8-1	$PGA_M = F_{PGA} PGA$	0.212g
2019 CBC	Figure 1613.2.1(1)	Short-Period MCE at 0.2s, S_s	0.406g
	Figure 1613.2.1(2)	1.0s Period MCE, S_1	0.206g
	Table 1613.2.3(1)	Site Coefficient, F_a	1.300
	Table 1613.2.3(2)	Site Coefficient, F_v	1.500
	Equation 16-36	Adjusted MCE Spectral Response Parameters, $S_{MS} = F_a S_s$	0.528g
	Equation 16-37	Adjusted MCE Spectral Response Parameters, $S_{M1} = F_v S_1$	0.309g
	Equation 16-38	Design Spectral Acceleration Parameters, $S_{DS} = \frac{2}{3} S_{MS}$	0.352g
	Equation 16-39	Design Spectral Acceleration Parameters, $S_{D1} = \frac{2}{3} S_{M1}$	0.206g
	Table 1613.2.5(1)	Seismic Design Category (Short Period), Occupancy I to III	C
	Table 1613.2.5(1)	Seismic Design Category (Short Period), Occupancy IV	D
Table 1613.2.5(2)	Seismic Design Category (1-Sec Period), Occupancy I to IV	D	

*Based on the online calculator available at <https://earthquake.usgs.gov/ws/designmaps/>

Earthquake Induced Liquefaction, Settlement, and Surface Rupture Potential

Liquefaction is the sudden loss of soil shear strength and sudden increase in porewater pressure caused by shear strains, as could result from an earthquake. Research has shown that saturated, loose to medium-dense sands with a silt content less than about 25 percent and located within the top 40 feet are most susceptible to liquefaction and surface rupture/lateral spreading.

Due to the absence of permanently elevated groundwater table, the relatively low seismicity of the area and the relatively shallow depth to rock, the potential for seismically induced damage due to liquefaction, surface ruptures, and settlement is considered low. For the above-mentioned reasons mitigation for these potential hazards is not considered necessary for the development of this project.

Static and Seismically Induced Slope Instability

The existing slopes on the project site were observed to have adequate vegetation on the slope face, appropriate drainage away from the slope face, and no apparent tension cracks or slump blocks in the slope face or at the head of the slope. No other indications of slope instability such as seeps or springs were observed. Additionally, due to the absence of permanently elevated groundwater table, the relatively low seismicity of the area, and the relatively shallow depth to bedrock, the potential for seismically induced slope instability for the existing slopes is considered low.

5.0 DISCUSSION AND CONCLUSIONS

Based upon the results of our field explorations, findings, and analysis described above, it is our opinion that construction of the proposed improvements is feasible from a geotechnical standpoint, provided the recommendations contained in this report are incorporated into the design plans, specifications, and implemented during construction. The native soils, once processed and compacted as recommended below, may be considered "engineered" and suitable for support of the planned improvements.



Geotechnical Considerations for Development

The project site is generally comprised of a thin layer of soils over shallow rock which is considered suitable for support of the proposed improvements. Generally, issues associated with development on similar sites are associated with the excavation of shallow rock and the presence of seepage at the soil to rock contact. Sites on slopes, such as those present at the project site, are generally developed by either using a daylight basement configuration, by building a larger pad with a slope or supporting retaining wall, or a combination of both methods. Additionally, buildings spanning across transition lines (e.g., rock to soil, or native soils to engineered fills) may be more prone to differential settlements compared to sites built on relatively flat lots.

Based on the configuration presented in the Reference 2 plans, it appears that the proposed buildings will likely be above the road and be supported by native soils or rock and engineered fills on the order of 2 feet or less. For these conditions, we have included the comments below. The geotechnical recommendations for this project are presented in the following sections.

- This report includes a recommendation for compaction of engineered fills to 95 percent and a minimum of 18 inches of embedment for foundations to reduce the potential for differential settlement.
- Due to the strength of rock, it may be difficult to excavate utilities. Consideration may be given to pre-excavating utility alignments during the building pad grading when larger equipment could be used and there is more site access. Some sites with shallow rock overexcavate the rock approximately 2 feet from finish grade during grading to improve landscape performance and later utility installations.

6.0 SITE GRADING AND EARTHWORK IMPROVEMENTS

Excavation Characteristics

The exploratory test pits were excavated using a CAT 303.5E mini excavator equipped with a 12-inch-wide bucket. The degree of difficulty encountered in excavating our test pits is an indication of the effort that will be required for excavation during construction. Based on our test pits, we expect that the site soils can be excavated using conventional earthmoving equipment such as a Caterpillar D6 to D8 for grading and rubber-tired backhoe for trench excavations not extending to the underlying bedrock materials.

The underlying bedrock materials can likely be excavated to depths of several feet using dozers equipped with rippers. We expect that the upper, weathered portion of the rock, indicated to extend up to approximately 3 feet below the rock surface at most locations, will require use of a Caterpillar D9 equipped with a single or multiple shank rippers, or similar equipment. We anticipate that a ripper equipped D9 can penetrate at least as deep as our test pits at most locations with moderate effort. Blasting cannot be ruled out in areas of resistant rock.

Where hard rock cuts in fractured rock are proposed, the orientation and direction of ripping will likely play a large role in the rippability of the material. When hard rock is encountered, we should be contacted to provide additional recommendations prior to performing an alternative such as blasting.



Utility trenches will likely encounter hard rock excavation conditions especially in deeper cut areas. Utility contractors should be prepared to use special rock trenching equipment such as large excavators (Komatsu PC400 or CAT 345 or equivalent). Blasting to achieve utility line grades, especially in planned cut areas, cannot be precluded. Water inflow into any excavation approaching the hard rock surface is likely to be experienced in all but the driest summer and fall months. Pre-ripping during mass grading may be beneficial and should be considered with the Geotechnical Engineer prior to, or during mass grading.

Soil Moisture Considerations

The compaction of soil to a desired relative compaction is dependent on conditioning the soil to a target range of moisture content. Moisture contents that are excessively dry or wet could limit the ability of the contractor to compact soils to the requirements for engineered fill. When dry, moisture should be added to the soil and the soils blended to improve consistency. Wet soil will need to be dried to become compactable. Generally, this includes blending and working the soil to avoid trapping moisture below a dryer surficial crust. Other options are available to reduce the time involved but typically have higher costs and require more evaluation prior to implementation.

The largest contributor to excessive soil moisture is generally precipitation and seepage during the rainy season. In recognition of this, we suggest that consideration be given to the seasonal limitations and costs of winter grading operations on the site. Special attention should be given regarding the drainage of the project site. If the project is expected to work through the wet season, the contractor should install appropriate temporary drainage systems at the construction site and should minimize traffic over exposed subgrades due to the moisture-sensitive nature of the on-site soils. During wet weather operations, the soil should be graded to drain and should be sealed by rubber tire rolling to minimize water infiltration.

Site Preparation

Preparation of the project site should involve site drainage controls, dust control, clearing and stripping, overexcavation and recompaction of loose native soils, and exposed grade compaction considerations. The following paragraphs state our geotechnical comments and recommendations concerning site preparation.

Site Drainage Controls

We recommend that initial site preparation involve intercepting and diverting any potential sources of surface or near-surface water within the construction zones. Because the selection of an appropriate drainage system will depend on the water quantity, season, weather conditions, construction sequence, and methods used by the contractor, final decisions regarding drainage systems are best made in the field at the time of construction. All drainage and/or water diversion performed for the site should be in accordance with the Clean Water Act and applicable Storm Water Pollution Prevention Plan.

Dust Control

Dust control provisions should be provided for as required by the local jurisdiction's grading ordinance (i.e. water truck or other adequate water supply during grading). Dust control is the purview of the grading contractor.



Clearing and Stripping of Organic Materials

Clearing and stripping operations should include the removal of all organic laden materials including trees, bushes, root balls, root systems, and any soft or loose soil generated by the removal operations. Short or mowed dry grasses may be pulverized and lost within fill materials provided no concentrated pockets of organics result. It is the responsibility of the grading contractor to remove excess organics from the fill materials. **No more than 2 percent of organic material, by weight, should be allowed within the fill materials at any given location.** Preserved trees may require tree root protection which should be addressed on an individual basis by a qualified arborist.

Our recommendations are based on limited windows into the surface and interpretations thereof; therefore, a representative of our firm should be present during site clearing operations to identify the location and depth of potential fills or loose soils, some of which may not have been found during our evaluation. We should also be present to observe removal of deleterious materials, and to identify any existing site conditions which may require mitigation or further recommendations prior to site development.

Overexcavation and Recompanction of Loose Native Soils

Following general site clearing, all existing loose or saturated native soils within the development footprint should be overexcavated down to firm native materials and backfilled with engineered fill as detailed in the engineered fill section below. Any depressions extending below final grade resulting from the removal of fill materials or other deleterious materials should be properly prepared as discussed below and backfilled with engineered fill.

Exposed Grade Compaction

Exposed soil grades following initial site preparation activities and overexcavation operations should be scarified to a minimum depth of 8 inches and compacted to the requirements for engineered fill. Generally, where rock conditions are exposed, no scarification should be necessary; however, these surfaces should be moisture conditioned and compacted to mitigate disturbance resulting from site preparation. Prior to placing fill, the exposed grades should be in a firm and unyielding state. Any localized zones of soft or pumping soils observed within the exposed grade should either be scarified and recompacted or be overexcavated and replaced with engineered fill as detailed in the engineered fill section below.

Engineered Fill Criteria

All materials placed as fills on the site should be placed as "Engineered Fill" which is observed, tested, and compacted as described in the following paragraphs.

Suitability of Onsite Materials

We expect that soil generated from excavations on the site, excluding deleterious material, may be used as engineered fill provided the material does not exceed 8 inches in maximum dimension.

Fill Placement and Compaction

Engineered fills should be placed in thin horizontal lifts not to exceed 8 inches in uncompacted thickness. If the contractor can achieve the recommended relative compaction using thicker lifts, the method may be judged acceptable based on field verification by a representative of our firm using standard density testing procedures. Lightweight compaction equipment may require thinner lifts to achieve the recommended relative compaction. Fills should have a maximum particle size of 8 inches unless approved by our firm.



The relative compaction of engineered fills is based on the maximum density and optimum moisture determined through the ASTM D1557 test method. We have considered the potential for differential settlement for this site and recommend that the engineered fills be placed at a relative compaction of 95 percent. Depending on the moisture condition of the soils, the engineered fills may require moisture conditioning to be within a suitable compaction range.

Our firm should be requested for consultation, observation, and testing for the earthwork operations prior to the placement of any fills. Fill soil compaction should be evaluated by means of in-place density tests performed during fill placement so that adequacy of soil compaction efforts may be determined as earthwork progresses.

Method Specification: Soils exceeding 30 percent rock by mass may be considered non-testable by conventional methods. The materials may be placed as engineered fill if placed in accordance with the following method specification during full time observation by a representative of our firm.

Soils should be moisture conditioned and compacted in place by a minimum of four completely covering passes with a Caterpillar 825, or approved equivalent. The compactor's last two passes should be at 90 degrees to the initial passes. In areas where 95 percent relative compaction is designated, an additional two passes should be applied in each direction, with three completely covering passes made at 90 degrees to the initial three passes. Engineered fill should be constructed in lifts not exceeding 12 inches in uncompacted thickness, moisture conditioned and compacted in accordance with the above specification. Additional passes as deemed necessary during fill placement to achieve the desired condition based upon field conditions may be recommended.

Import Materials

The recommendations presented in this report are based on the assumption that the import materials will be similar to the materials present at the project site. High quality materials are preferred for import; however, these materials can be more dependent on source availability. Import material should be approved by our firm prior to transporting it to the project site.

Material for this project should consist of a material with the geotechnical characteristics presented below. If these requirements are not met, additional testing and evaluation may be necessary to determine the appropriate design parameters for foundations, pavement, and other improvements.

Table 3: Select Import Criteria

Behavior Property	Reference Document	Recommendation
Direct Shear Strength	ASTM D3080	≥ 32° when compacted
Plasticity Index	ASTM D4318	≤ 12
Expansion Index	ASTM D4829	≤ 20
Sieve Analysis	ASTM D1140	Not more than 30% Passing the No. 200 sieve



Slope Configuration and Grading

The project site is proposed to have cuts and fill with a maximum slope orientation of 2H:1V (Horizontal:Vertical). Generally, a cut slope orientation of 2H:1V is considered stable with the material types encountered on the site. A fill slope constructed at the same orientation is considered stable if compacted to the engineered fill recommendations as stated in the recommendations section of this report. All slopes should have appropriate drainage and vegetation measures to minimize erosion of slope soils.

Placement of Fills on Slopes

Placement of fill material on natural slopes should be stabilized by means of keyways and benches. Where the slope of the original ground equals or exceeds 5H:1V, a keyway should be constructed at the base of the fill. The keyway should consist of a trench excavated to a depth of at least 2 feet into firm, competent materials. The keyway trench should be at least 10 feet wide or as designated by our firm based on the conditions at the time of construction. Benches should be cut into the original slope as the filling operation proceeds. Each bench should consist of a level surface excavated at least 6 feet horizontally into firm soils or 4 feet horizontally into rock. The rise between successive benches should not exceed 36 inches. The need for subdrainage should be evaluated at the time of construction. Refer to Figure C-1 in Appendix C for typical keyway and bench construction.

Slope Face Compaction

All slope fills should be laterally overbuilt and cut back such that the required compaction is achieved at the proposed finish slope face. As a less preferable alternative, the slope face could be track walked or compacted with a wheel. If this second alternative is used, additional slope maintenance may be necessary.

Slope Drainage

Surface drainage should not be allowed to flow uncontrolled over any slope face. Adequate surface drainage control should be designed by the project civil engineer in accordance with the latest applicable edition of the CBC. All slopes should have appropriate drainage and vegetation measures to minimize erosion of slope soils.

7.0 DESIGN RECOMMENDATIONS

The contents of this section include recommendations for foundations, slabs-on-grade, retaining walls, pavements, and drainage.

Shallow Conventional Foundations

Shallow conventional foundation systems are considered suitable for construction of the planned improvements, provided that the site is prepared in accordance with the recommendations discussed in Section 6.0 of this report.

The provided values do not constitute a structural design of foundations which should be performed by the structural engineer. In addition to the provided recommendations, foundation design and construction should conform to applicable sections of the 2019 California Building Code.

Foundation Capacities

The foundation bearing and lateral capacities are presented in the table below. The allowable bearing capacity is for support of dead plus live loads based on the foundation configuration presented in this report. The allowable capacity may be increased by 1/3 for short-term wind and seismic loads. Lateral forces on structures may be resisted by passive pressure acting against the sides of shallow footings and/or friction between the foundation bearing material and the bottom of the footing. Section 1806.3 of the 2019 CBC allows for the combination of the friction factor and passive resistance value to lateral resistance. Consideration should be given to ignoring passive resistance where soils could be disturbed later or within 6 feet horizontally of the slope face.

Table 4: Foundation Capacities

Soil Type	Design Condition	Design Value	Applied Factor of Safety
Engineered Fill or Firm Native Soil	Allowable Bearing Capacity	2,200 psf	3.0
	Allowable Friction Factor*	0.45	1.5
	Allowable Passive Resistance	300 psf/ft	1.5
Rock	Allowable Bearing Capacity	4,000 psf	3.0
	Allowable Friction Factor*	0.50	1.5
	Allowable Passive Resistance	400 psf/ft	1.5

* Friction Factor is calculated as $\tan(\phi)$

Foundation Settlement

A total settlement of less than 1 inch is anticipated; a differential settlement of 0.5 inches in 25 feet is anticipated where foundations are bearing on like materials. The settlement criteria are based upon the assumption that foundations will be sized and loaded in accordance with the recommendations in this report.

Foundation Configuration

Conventional shallow foundations should be a minimum of 12 inches wide and founded a minimum of 12 inches below the lowest adjacent soil grade for single-story portions of the residence and 18 inches for foundations supporting a second story. Isolated pad foundations should be a minimum of 24 inches in plan dimension. A grade beam, having the same depth as the continuous footings, should also be cast across the vehicle openings of the residence garage.

Foundation reinforcement should be provided by the structural engineer. The reinforcement schedule should account for typical construction issues such as load consideration, concrete cracking, and the presence of isolated irregularities. At a minimum, we recommend that continuous footing foundations be reinforced with four No. 4 reinforcing bars, two located near the bottom of the footing and two near the top of the stem wall.

Foundation Influence Line and Slope Setback

All footings should be founded below an imaginary 2H:1V plane projected up from the bottoms of adjacent footings and/or parallel utility trenches, or to a depth that achieves a minimum horizontal clearance of 6 feet from the outside toe of the footings to the slope face, whichever requires a deeper excavation.



Subgrade Conditions

Footings should never be cast atop soft, loose, organic, slough, debris, nor atop subgrades covered by ice or standing water. A representative of our firm should be retained to observe all subgrades during footing excavations and prior to concrete placement so that a determination as to the adequacy of subgrade preparation can be made.

Shallow Footing / Stemwall Backfill

All footing/stemwall backfill soil should be compacted to the criteria for engineered fill as recommended in Section 6.0 of this report.

Slab-on-Grade Construction

It is our opinion that soil-supported slab-on-grade floors could be used for the main floor of the structures, contingent on proper subgrade preparation. Often the geotechnical issues regarding the use of slab-on-grade floors include proper soil support and subgrade preparation, proper transfer of loads through the slab underlayment materials to the subgrade soils, and the anticipated presence or absence of moisture at or above the subgrade level. We offer the following comments and recommendations concerning support of slab-on-grade floors. The slab design (concrete mix design, curing procedures, reinforcement, joint spacing, moisture protection, and underlayment materials) is the purview of the project Structural Engineer.

Slab Subgrade Preparation

All subgrades proposed to support slab-on-grade floors should be prepared and compacted to the requirements of engineered fill as discussed in Section 6.0 of this report.

Slab Underlayment

As a minimum for slab support conditions, the slab should be underlain by a minimum 4-inch-thick crushed rock layer that is covered by a minimum 10-mil thick moisture retarding plastic membrane. The membrane may only be functional when it is above the vapor sources. The bottom of the crushed rock layer should be above the exterior grade to act as a capillary break and not a reservoir, unless it is provided with an underdrain system. The slab design and underlayment should be in accordance with ASTM E1643 and E1745.

An optional 1-inch blotter sand layer placed above the plastic membrane, is sometimes used to aid in curing of the concrete. Although historically common, this blotter layer is not currently included in slabs designed according to the 2019 Green Building Code. When omitted, special wet curing procedures will be necessary. If installed, the blotter layer can become a reservoir for excessive moisture if inclement weather occurs prior to pouring the slab, excessive water collects in it from the concrete pour, or an external source of water enters above or bypasses the membrane.

Our experience has shown that vapor transmission through concrete is controlled through proper concrete mix design. As such, proper control of moisture vapor transmission should be considered in the design of the slab as provided by the project architect, structural or civil engineer. It should be noted that placement of the recommended plastic membrane, proper mix design, and proper slab underlayment and detailing per ASTM E1643 and E1745 will not provide a waterproof condition. If a waterproof condition is desired, we recommend that a waterproofing expert be consulted for slab design.



Slab Thickness and Reinforcement

Geotechnical reports have historically provided minimums for slab thickness and reinforcement for general crack control. The concrete mix design and construction practices can additionally have a large impact on concrete crack control. All concrete should be anticipated to crack. As such, these minimums should not be considered to be standalone items to address crack control, but are suggested to be considered in the slab design methodology.

In order to help control the growth of cracks in interior concrete from becoming significant, we suggest the following minimums. Interior concrete slabs-on-grade not subject to heavy loads, should be a minimum of 4-inches thick and reinforced. A minimum of No. 3 deformed reinforcing bars placed at 24 inches on center both ways, at the center of the structural section is suggested. Joint spacing should be provided by the structural engineer. Troweled joints recovered with paste during finishing or "wet sawn" joints should be considered every 10 feet on center. Expansion joint felt should be provided to separate floating slabs from foundations and at least at every third joint. Cracks will tend to occur at recurrent corners, curved or triangular areas and at points of fixity. Trim bars can be utilized at right angle to the predicted crack extending 40 bar diameters past the predicted crack on each side.

Vertical Deflections

Soil-supported slab-on-grade floors can deflect downward when vertical loads are applied, due to elastic compression of the subgrade. For preliminary design of concrete floors, a modulus of subgrade reaction of $k = 150$ psi per inch would be applicable for engineered fills.

Exterior Flatwork

Exterior concrete flatwork is recommended to have a 4-inch-thick rock cushion. This could consist of vibroplate compacted crushed rock or compacted $\frac{3}{4}$ -inch aggregate baserock. If exterior flatwork concrete is against the floor slab edge without a moisture separator it may transfer moisture to the floor slab. Expansion joint felt should be provided to separate exterior flatwork from foundations and at least at every third joint. Contraction / groove joints should be provided to a depth of at least $\frac{1}{4}$ of the slab thickness and at a spacing of less than 30 times the slab thickness for unreinforced flatwork, dividing the slab into nearly square sections. Cracks will tend to occur at recurrent corners, curved or triangular areas and at points of fixity. Trim bars can be utilized at right angle to the predicted crack extending 40 bar diameters past the predicted crack on each side.

Retaining Walls

Our design recommendations and comments regarding retaining walls for the project site are discussed below. *Retaining wall foundations should be designed in accordance with the Shallow Conventional Foundations section above.*

Retaining Wall Lateral Pressures

Based on our observations and testing, the retaining wall should be designed to resist lateral pressure exerted from a soil media having an equivalent fluid weight provided in the table below. The values presented below are not factored and are for conditions when firm native soil or engineered fill is used within the zone behind the wall defined as twice the height of the retaining wall. Additionally, the values do not account for the friction of the backfill on the retaining wall which may or may not be present depending on the wall materials and construction.

The lateral pressures presented in the table below include recommendations for earthquake loading which is required for structures to be designed in Seismic Design Categories D, E, or F per Section 1803.5.12.1 of the 2019 California Building Code. The lateral pressures presented have been calculated using the Mononobe-Okabe Method derived from Wood (1973) and modified by Whitman et al. (1991). The values are intended to be used as the multiplier for uniformly distributed loads and the parameter “H” is the total height of the wall including the footing but excluding any key, if used.

Table 5: Retaining Wall Pressures

Wall Type	Wall Slope Configuration	Equivalent Fluid Weight (pcf)	Lateral Pressure Coefficient	Earthquake Loading (plf)	
Free Cantilever	Flat	35	0.29	4H ²	Applied 0.6H above the base of the wall
	2H:1V	52	0.43	13H ²	
	3H:1V	44	0.36		
Restrained*	Flat	54	0.45		

* Restrained conditions shall be defined as walls which are structurally connected to prevent flexible yielding, or rigid wall configurations (i.e., walls with numerous turning points) which prevent the yielding necessary to reduce the driving pressures from an at-rest state to an active state.

Generalized Design Values

Some software and design methods do not use the equivalent fluid weight method presented above; instead, they use design soil properties for a given soil condition such as the internal friction angle, cohesion, and bulk unit weight. Generally, this occurs for keyed or interlocking non-mortared walls such as segmental block (Basalite, Keystone, Allan Block, etc.) or rockery walls. When this occurs, the following soil parameters would be applicable for design with the onsite native materials in a firm condition or for engineered fills. The seismic coefficient is considered to be ½ of the adjusted peak ground acceleration for the site conditions is given in Section 4.0 of this report. Some software allows for the extension of the Mononobe-Okabe Method beyond the conventional limitations and, if the method is applied, could calculate seismic values significantly higher than those provided by the multiplier method provided above.

Table 6: Generalized Design Parameters

Internal Angle of Friction	Cohesion	Bulk Unit Weight	Seismic Coefficient, Kh
33°	0 psf	120 pcf	0.108g

Wall Drainage

The criteria presented above is based on fully drained conditions as detailed in the attached Figure C-2, Appendix C. For these conditions, we recommend that a blanket of filter material be placed behind all proposed walls. Permeable materials are specified in Section 68 of the California Department of Transportation Standard Specifications, current edition. The filter material should conform to Class 1, Type B permeable material in combination with a filter fabric to separate the open graded gravel/rock from the surrounding soils. Generally, a clean ¾ inch crushed rock should be acceptable. Consistent with Caltrans Standards, when Class 2 permeable materials are used, the filter fabric may be omitted unless otherwise designed.

The blanket of filter material should be a minimum of 12-inches thick and should extend from the bottom of the wall to within 12 inches of the ground surface. The top 12 inches of wall backfill should consist of a compacted soil cap. A filter fabric having specifications equal to or greater than those for Mirafi 140N should be placed between the gravel filter material and the surrounding soils to reduce the potential for infiltration of soil into the gravel. A 4-inch diameter drain pipe should be installed near the bottom of the filter blanket with perforations facing down. The



drainpipe should be underlain by at least 4 inches of filter-type material. An adequate gradient should be provided along the top of the foundation to discharge water that collects behind the retaining wall to a controlled discharge system.

The configuration of a long retaining wall generally does not allow for a positive drainage gradient within the perforated drain pipe behind the wall since the wall footing is generally flat with no gradient for drainage. Where this condition is present, to maintain a positive drainage behind the walls, we recommend that the wall drains be provided with a discharge to an appropriate non-erosive outlet a maximum of 50 feet on center. **In addition, if the wall drain outlets are temporarily stubbed out in front of the walls for future connection during building construction, it is imperative that the outlets be routed into the tight pipe area drainage system and not buried and rendered ineffective.**

Asphalt Concrete Pavement Design

We understand that asphalt pavements will be used for the associated roadways. The following comments and recommendations are given for pavement design and construction purposes. All pavement construction and materials used should conform to applicable sections of the latest edition of the California Department of Transportation Standard Specifications.

Relative Compaction

The asphalt concrete pavement section should be constructed to achieve the minimum relative compactions specified in Section 6.0 of this report. Deviation from the following table should be reviewed by the governing agency when the pavements are to be constructed within their right-of-way. Final acceptance of the constructed pavement section is the purview of the governing agency or owner of the site.

Subgrade Stability

All subgrades and aggregate base should be proof-rolled with a full water truck or equivalent immediately before paving, in order to evaluate their condition. If unstable subgrade conditions are observed, these areas should be overexcavated down to firm materials and the resulting excavation backfilled with suitable materials for compaction (i.e., drier native soils or aggregate base). Areas displaying significant instability may require geotextile stabilization fabric within the overexcavated area, followed by placement of aggregate base. Final determination of any required overexcavation depth and stabilization fabric should be based on the conditions observed during subgrade preparation.

Subgrade Resistance Value

Critical features that govern the durability of a pavement section include the stability of the subgrade; the presence or absence of moisture, free water, and organics; the fines content of the subgrade soils; the traffic volume; and the frequency of use by heavy vehicles. Soil conditions can be defined by a soil resistance value, or "R-Value," and traffic conditions can be defined by a Traffic Index (TI).

Laboratory testing was performed on a bulk sample considered to be representative of the materials expected to be exposed at subgrade. The tested soil had an R-Value of 45, which was used in our design.



Design values provided are based upon properly drained subgrade conditions. Although the R-Value design to some degree accounts for wet soil conditions, proper surface and landscape drainage design is integral in performance of adjacent street sections with respect to stability and degradation of the asphalt. We should review pavement subgrades to determine the appropriateness of the provided sections, and provide additional pavement design recommendations as field conditions dictate.

Due to the redistribution of materials that occurs during grading operations, we should review pavement subgrades to determine the appropriateness of the provided sections.

Section Thickness

The recommended design thicknesses presented in the following table were calculated in accordance with the methods presented in the Sixth Edition of the California Department of Transportation Highway Design Manual. A varying range of traffic indices are provided for use by the project Civil Engineer for roadway design.

Table 8: Asphalt Pavement Section Recommendations

Design Traffic Indices	Alternative Pavement Sections (Inches)	
	Asphalt Concrete *	Aggregate Base **
4.5	2.5	6.0
	3.0	4.5
5.0	2.5	7.0
	3.0	6.0
5.5	3.0	7.5
	3.5	6.5
6.0	3.0	9.0
	3.5	8.0
6.5	3.5	9.5
	4.0	8.5
7.0	4.0	10.0
	4.5	9.0

* Asphalt Concrete: must meet specifications for Caltrans Hot Mix Asphalt Concrete

** Aggregate Base: must meet specifications for Caltrans Class II Aggregate Base (R-Value = minimum 78)

Portland Cement Concrete Pavement Design

We understand that Portland cement concrete pavements may be considered for various aspects of the complex. The American Concrete Institute (ACI) Concrete Pavement Design method (ACI 330R-08) was used for design of the exterior concrete (rigid) pavements at the site.

Relative Compaction

The asphalt concrete pavement section should be constructed to achieve the minimum relative compactions specified in Section 6.0 of this report. Deviation from the following table should be reviewed by the governing agency when the pavements are to be constructed within their right-of-way. Final acceptance of the constructed pavement section is the purview of the governing agency.

Subgrade Stability

All subgrades and aggregate base should be proof-rolled with a full water truck or equivalent immediately before paving, in order to evaluate their condition.

Soil Design Parameters

The pavement thicknesses were evaluated based on the soil design parameters provided in the following table.

Table 9: Soil Parameters

Subgrade Soil Description	k, Modulus of Subgrade Reaction*	Base Course
Sandy SILT	160 pci	6 inches

* Based on an R-Value of < 5 as recommended above and correlated to a k-Value recommended by ACI 330R.

Section Thickness

Based on the subgrade soil parameters shown in the above table, the recommended concrete thicknesses for various traffic descriptions are presented in the table below. The recommended thicknesses provided below assume the use of plain (non-reinforced) concrete pavements.

Table 10: Concrete Pavement Section Recommendations (Untreated, R-Value < 5)

Category	ADTT*	Pavement Traffic Description	Thickness (inches)	
			3000 psi**	4000 psi**
A	1	Car parking areas and access lanes Autos, pickups, and panel trucks only	4.5	4.5
A	10		5.0	5.0
B	25	Shopping center entrance and service lanes Bus parking areas and interior lanes Single-unit truck parking areas and interior lanes	6.0	5.5
B	300		6.5	6.0
C	100	Roadway Entrances and Exterior Lanes	6.5	6.5
C	300		7.0	6.5
C	700		7.0	7.0

* Average Daily Truck Traffic

** 28-day concrete compressive strength

Jointing and Reinforcement

From a geotechnical perspective, contraction joints should be placed in accordance with the American Concrete Institute (ACI) recommendations which include providing a joint spacing about 30 times the slab thickness up to a maximum of 10 feet. The joint patterns should also divide the slab into nearly square panels. If increased joint spacing is desired, reinforcing steel should be installed within the pavement in accordance with ACI recommendations. Final determination of steel reinforcement configurations (if used within the pavements) remains the purview of the Project Structural Engineer.

Drainage

In order to maintain the engineering strength characteristics of the soil presented for use in this report, maintenance of the site will need to be performed. This maintenance generally includes, but is not limited to, proper drainage and control of surface and subsurface water which could affect structural support and fill integrity. A difficulty exists in determining which areas are prone to the negative impacts resulting from high moisture conditions due to the diverse nature of potential sources of water; some of which are outlined in the paragraph below. We suggest that measures be installed to minimize exposure to the adverse effects of moisture, but this will not guarantee that excessive moisture conditions will not affect the structures.

Some of the diverse sources of moisture could include water from landscape irrigation, annual rainfall, offsite construction activities, runoff from impermeable surfaces, collected and channeled water, and water perched in the subsurface soils. Some of these sources can be controlled through drainage features installed either by the owner or contractor. Others may not become evident until they, or the effects of the presence of excessive moisture, are visually observed on the property.

Some measures that can be employed to minimize the buildup of moisture include, but are not limited to proper backfill materials and compaction of utility trenches within the footprint of the proposed structures; grout plugs at foundation penetrations; collection and channeling of drained water from impermeable surfaces (i.e. roofs, concrete or asphalt paved areas); installation of subdrain/cut-off drain provisions; utilization of low flow irrigation systems; education to the proposed owners of proper design and maintenance of landscaping and drainage facilities that they or their landscaper installs.

Drainage Adjacent to Buildings

All grades should provide rapid removal of surface water runoff; ponding water should not be allowed on building pads or adjacent to foundations or other structural improvements (during and following construction). All soils placed against foundations during finish grading should be compacted to minimize water infiltration. Finish and landscape grading should include positive drainage away from all foundations. Section 1808.7.4 of the 2019 California Building Code (CBC) states that for graded soil sites, the top of any exterior foundation shall extend above the elevation of the street gutter at the point of discharge or the inlet of an approved drainage device a minimum of 12 inches plus 2 percent. If overland flow is not achieved adjacent to buildings, the drainage device should be designed to accept flows from a 100-year event. Grades directly adjacent to foundations should be no closer than 8 inches from the top of the slab (CBC 2304.12.1.2), and weep screeds are to be placed a minimum of 4 inches clear of soil grades and 2 inches clear of concrete or other hard surfacing (CBC 2512.1.2). From this point, surface grades should slope a minimum of 2 percent away from all foundations for at least 5 feet but preferably 10 feet, and then 2 percent along a drainage swale to the outlet (CBC 1804.4). Downspouts should be tight piped via an area drain network and discharged to an appropriate non-erosive outlet away from all foundations.

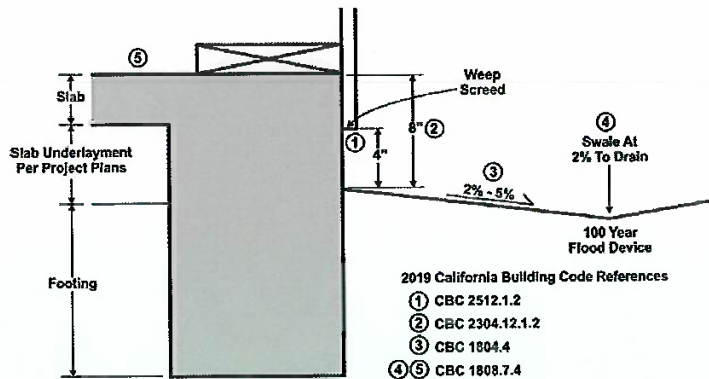

Typical 2019 California Building Code
Drainage Requirements



The above referenced elements pertaining to drainage of the proposed structures is provided as general acknowledgement of the California Building Code requirements, restated and graphically illustrated for ease of understanding. Surface drainage design is the purview of the Project Architect/Civil Engineer. Review of drainage design and implementation adjacent to the building envelopes is recommended as performance of these improvements is crucial to the performance of the foundation and construction of rigid improvements.

Post Construction

All drainage related issues may not become known until after construction and landscaping are complete. Therefore, some mitigation measures may be necessary following site development. Landscape watering is typically the largest source of water infiltration into the subgrade. Given the soil conditions on site, excessive or even normal landscape watering could contribute to moisture related problems and/or cause distress to foundations and slabs, pavements, and underground utilities, as well as creating a nuisance where seepage occurs.

Low Impact Development Standards

Low Impact Development or LID standards have become a consideration for many projects in the region. LID standards are intended to address and mitigate urban storm water quality concerns. These methods include the use of Source Controls, Run-off Reduction and Treatment Controls. For the purpose of this report use of Run-off Reduction measures and some Treatment Controls may impact geotechnical recommendations for the project.

Youngdahl Consulting Group, Inc. did not perform any percolation or infiltration testing for the site as part of the Geotechnical Investigation. A review of soil survey and the data collected from test pits indicate that soils within the project are Hydrologic Soil Group C (low permeability). Based on this condition, use of infiltration type LID methods (infiltration trenches, dry wells, infiltration basins, permeable pavements, etc.) should not be considered without addressing applicable geotechnical considerations/implications. As such, use of any LID measure that would require infiltration of discharge water to surfaces adjacent to structures/pavement or include infiltration type measures should be reviewed by Youngdahl Consulting Group, Inc. during the design process.

8.0 DESIGN REVIEW AND CONSTRUCTION MONITORING

Geotechnical engineering can be affected by natural variability of soils and, as with many projects, the contents of this report could be used and interpreted by many design professionals for the application and development of their plans. For these reasons, we recommend that our firm provide support through plan reviews and construction monitoring to aid in the production of a successful project.

Plan Review

The design plans and specifications should be reviewed and accepted by Youngdahl Consulting Group, Inc. prior to contract bidding. A review should be performed to determine whether the recommendations contained within this report are still applicable and/or are properly interpreted and incorporated into the project plans and specifications. Modifications to the recommendations provided in this report or to the design may be necessary at the time of our review based on the proposed plans.



Construction Monitoring

Construction monitoring is a continuation of geotechnical engineering to confirm or enhance the findings and recommendations provided in this report. It is essential that our representative be involved with all grading activities in order for us to provide supplemental recommendations as field conditions dictate. Youngdahl Consulting Group, Inc. should be notified at least two working days before site clearing or grading operations commence, and should observe the stripping of deleterious material, overexcavation of soft soils and existing fills (if present), and provide consultation, observation, and testing services to the grading contractor in the field. At a minimum, Youngdahl Consulting Group, Inc. should be retained to provide services listed in Table 7 below.

The recommendations included in this report have been based in part on assumptions about strata variations that may be tested only during earthwork. Accordingly, these recommendations should not be applied in the field unless Youngdahl Consulting Group, Inc. is retained to perform construction observation and thereby provide a complete professional geotechnical engineering service through the observational method. Youngdahl Consulting Group, Inc. cannot assume responsibility or liability for the adequacy of its recommendations when they are used in the field without Youngdahl Consulting Group, Inc. being retained to observe construction.

Post Construction Drainage Monitoring

Due to the elusive nature of subsurface water, the alteration of water features for development, and the introduction of new water sources, all drainage related issues may not become known until after construction and landscaping are complete. Youngdahl Consulting Group, Inc. can provide consultation services upon request that relate to proper design and installation of drainage features during and following site development.

9.0 LIMITATIONS AND UNIFORMITY OF CONDITIONS

1. This report has been prepared for the exclusive use of the addressee of this report for specific application to this project. The addressee may provide their consultants authorized use of this report. Youngdahl Consulting Group, Inc. has endeavored to comply with generally accepted geotechnical engineering practice common to the local area. Youngdahl Consulting Group, Inc. makes no other warranty, expressed or implied.
2. As of the present date, the findings of this report are valid for the property studied. With the passage of time, changes in the conditions of a property can occur whether they be due to natural processes or to the works of man on this or adjacent properties. Legislation or the broadening of knowledge may result in changes in applicable standards. Changes outside of our control may cause this report to be invalid, wholly or partially. Therefore, this report should not be relied upon after a period of three years without our review nor should it be used or is it applicable for any properties other than those studied.
3. Section [A] 107.3.4 of the 2019 California Building Code states that, in regard to the design professional in responsible charge, the building official shall be notified in writing by the owner if the registered design professional in responsible charge is changed or is unable to continue to perform the duties.

WARNING: Do not apply any of this report's conclusions or recommendations if the nature, design, or location of the facilities is changed. If changes are contemplated, Youngdahl Consulting Group, Inc. must review them to assess their impact on this report's applicability. Also note that Youngdahl Consulting Group, Inc. is not responsible for any claims, damages, or liability associated with any other party's interpretation of this report's subsurface data or



reuse of this report's subsurface data or engineering analyses without the express written authorization of Youngdahl Consulting Group, Inc.

4. The analyses and recommendations contained in this report are based on limited windows into the subsurface conditions and data obtained from subsurface exploration. The methods used indicate subsurface conditions only at the specific locations where samples were obtained, only at the time they were obtained, and only to the depths penetrated. Samples cannot be relied on to accurately reflect the strata variations that usually exist between sampling locations. Should any variations or undesirable conditions be encountered during the development of the site, Youngdahl Consulting Group, Inc. will provide supplemental recommendations as dictated by the field conditions.



Table 7: Checklist of Recommended Services

	Item Description	Recommended	Not Anticipated
1	Provide foundation design parameters	Included	
2	Review grading plans and specifications	✓	
3	Review foundation plans and specifications	✓	
4	Observe and provide recommendations regarding demolition	✓	
5	Observe and provide recommendations regarding site stripping	✓	
6	Observe and provide recommendations on moisture conditioning removal, and/or recompaction of unsuitable existing soils	✓	
7	Observe and provide recommendations on the installation of subdrain facilities	✓	
8	Observe and provide testing services on fill areas and/or imported fill materials	✓	
9	Review as-graded plans and provide additional foundation recommendations, if necessary	✓	
10	Observe and provide compaction tests on storm drains, water lines and utility trenches	✓	
11	Observe foundation excavations and provide supplemental recommendations, if necessary, prior to placing concrete	✓	
12	Observe and provide moisture conditioning recommendations for foundation areas and slab-on-grade areas prior to placing concrete		✓
13	Provide design parameters for retaining walls	Included	
14	Provide finish grading and drainage recommendations	Included	
15	Provide geologic observations and recommendations for keyway excavations and cut slopes during grading	✓	
16	Excavate and recompact all test pits within structural areas	✓	

APPENDIX A

Field Study

Vicinity Map

Site Plan

Logs of Exploratory Test Pits

Soil Classification Chart and Log Explanation



Introduction

The contents of this appendix shall be integrated with the Geotechnical Engineering Study of which it is a part. They shall not be used in whole or in part as a sole source for information or recommendations regarding the subject site.

Our field study included a site reconnaissance by a Youngdahl Consulting Group, Inc. representative followed by a subsurface exploration program conducted on 17 January 2022, which included the excavation of 4 test pits under his direction at the approximate locations shown on Figure A-2, this Appendix. Excavation of the test pits was accomplished with a CAT 303.5E mini excavator with 12-inch-wide bucket. The bulk and bag samples collected from the test pits were returned to our laboratory for further examination and testing.

The Exploratory Test Pit Logs describe the vertical sequence of soils and materials encountered in each test pit, based primarily on our field classifications and supported by our subsequent laboratory examination and testing. Where a soil contact was observed to be gradual, our logs indicate the average contact depth. Our logs also graphically indicate the sample type, sample number, and approximate depth of each soil sample obtained from the test pits.

The soils encountered were logged during excavation and provide the basis for the "Logs of Test Pits", Figures A-3 through A-6, this Appendix. These logs show a graphic representation of the soil profile, the location, and depths at which samples were collected.

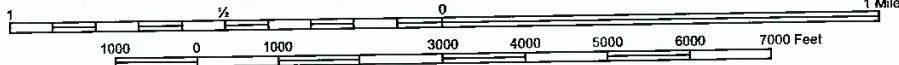
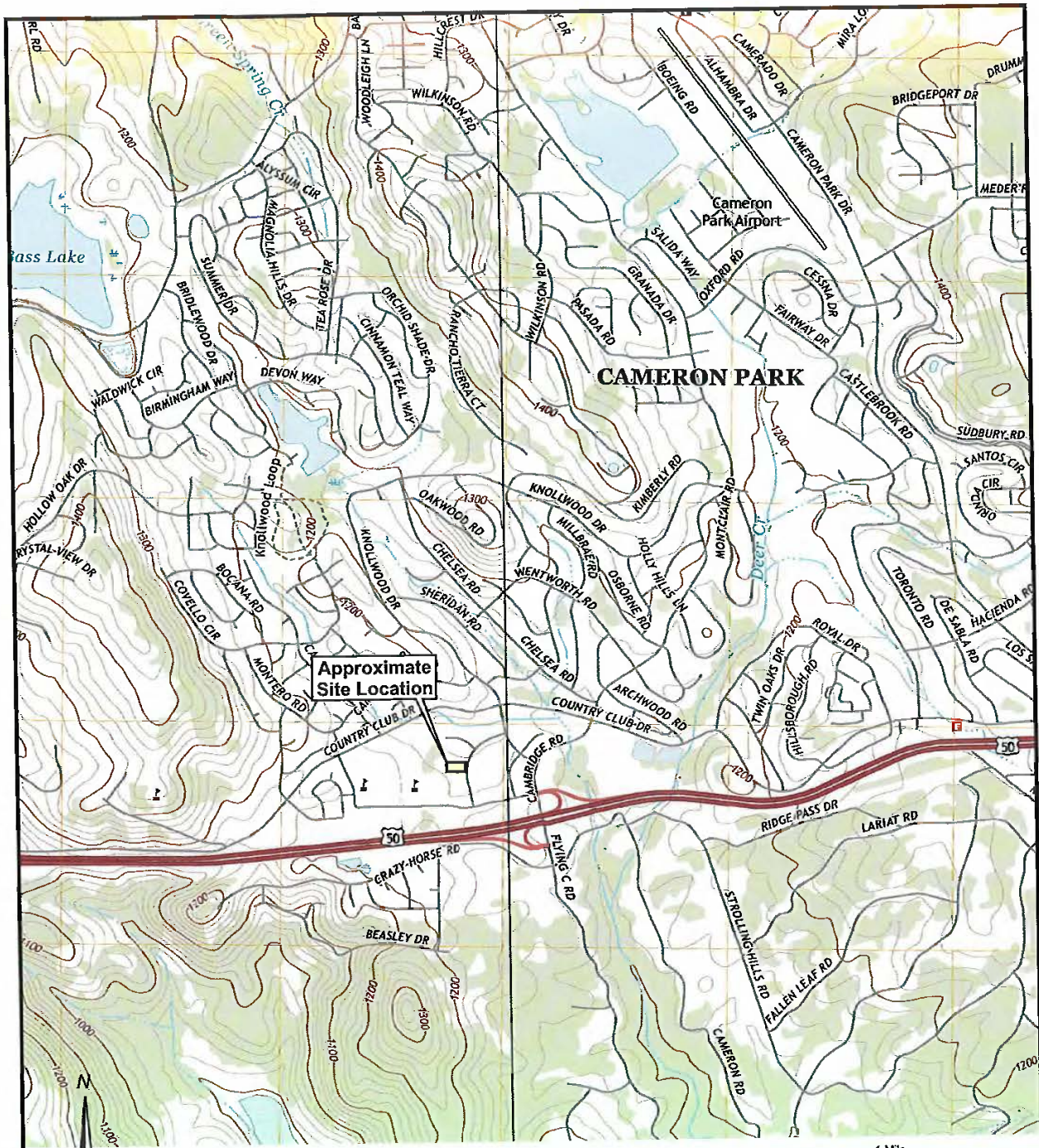

Scale: 1:24,000

BASE MAP REFERENCE: U.S.G.S. 7.5 Minute Topographic Series, Single Springs & Clarksville Quadrangles, Dated 2018

 YOUNGDAHL CONSULTING GROUP, INC. <small>ESTABLISHED 1984</small>	Project No.: E22014.000 March 2022	VICINITY MAP Greenwood Estates Cameron Park, California	FIGURE A-1
---	--	--	-----------------------------



TP-1 = Approximate Test Pit Locations

REFERENCE: Tentative Map, Greenwood Estates, Lebeck Engineering Inc, Sheet TM, Dated 11/16/2021;
Overlaid onto Google Earth, Aerial Data Dated 6/3/2021

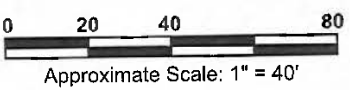

Project No.:
E22014.000
March 2022

SITE PLAN
Greenwood Estates
Cameron Park, California

FIGURE
A-2

Logged By: MAP	Date: 17 January 2022	Lat / Lon: ~N° / ~W°	Pit No. TP-1
Equipment: CAT 303.5E with 12" Bucket	Pit Orientation: N - S	Elevation: ~	

Depth (Feet)	Geotechnical Description & Unified Soil Classification	Sample	Tests & Comments
@ 0' - 2'	Red brown to yellow brown fine sandy SILT (ML) , soft to medium stiff, moist		
@ 2' - 2.5'	Olive to green grey metavolcanic BEDROCK , moderately to highly weathered, closely jointed, moderately soft, with clay pockets		
@ 2.5' - 4'	<i>Grades without clay, hard</i>		
	Test pit terminated at 4' (practical refusal) No free groundwater encountered No caving noted		

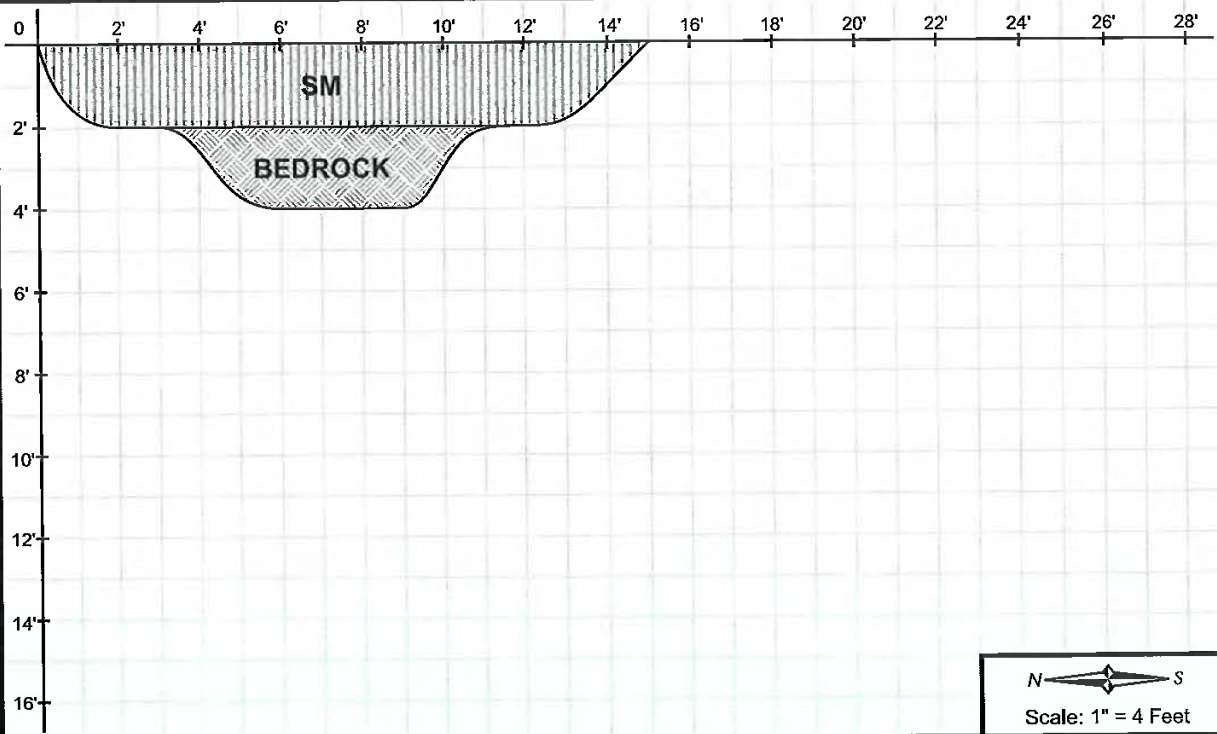

Note: The test pit log indicates subsurface conditions only at the specific location and time noted. Subsurface conditions, including groundwater levels, at other locations of the subject site may differ significantly from conditions which, in the opinion of Youngdahl Consulting Group, Inc., exist at the sampling locations. Note, too, that the passage of time may affect conditions at the sampling locations.

 YOUNGDAHL CONSULTING GROUP, INC. <small>ESTABLISHED 1984</small>	Project No.: E22014.000	EXPLORATORY TEST PIT LOG Greenwood Estates Cameron Park, California	FIGURE A-3
	March 2022		

Logged By: MAP		Date: 17 January 2022		Lat / Lon: ~N° / ~W°		Pit No. TP-2	
Equipment: CAT 303.5E with 12" Bucket				Pit Orientation: E - W		Elevation: ~	
Depth (Feet)	Geotechnical Description & Unified Soil Classification			Sample	Tests & Comments		
@ 0' - 2'	Red brown to yellow brown fine sandy SILT (ML) , soft to medium stiff, moist						
@ 2' - 3.5'	Olive to green grey metavolcanic BEDROCK , slightly to highly weathered, closely jointed, moderately hard to hard						
	Test pit terminated at 3.5' (practical refusal) No free groundwater encountered No caving noted						

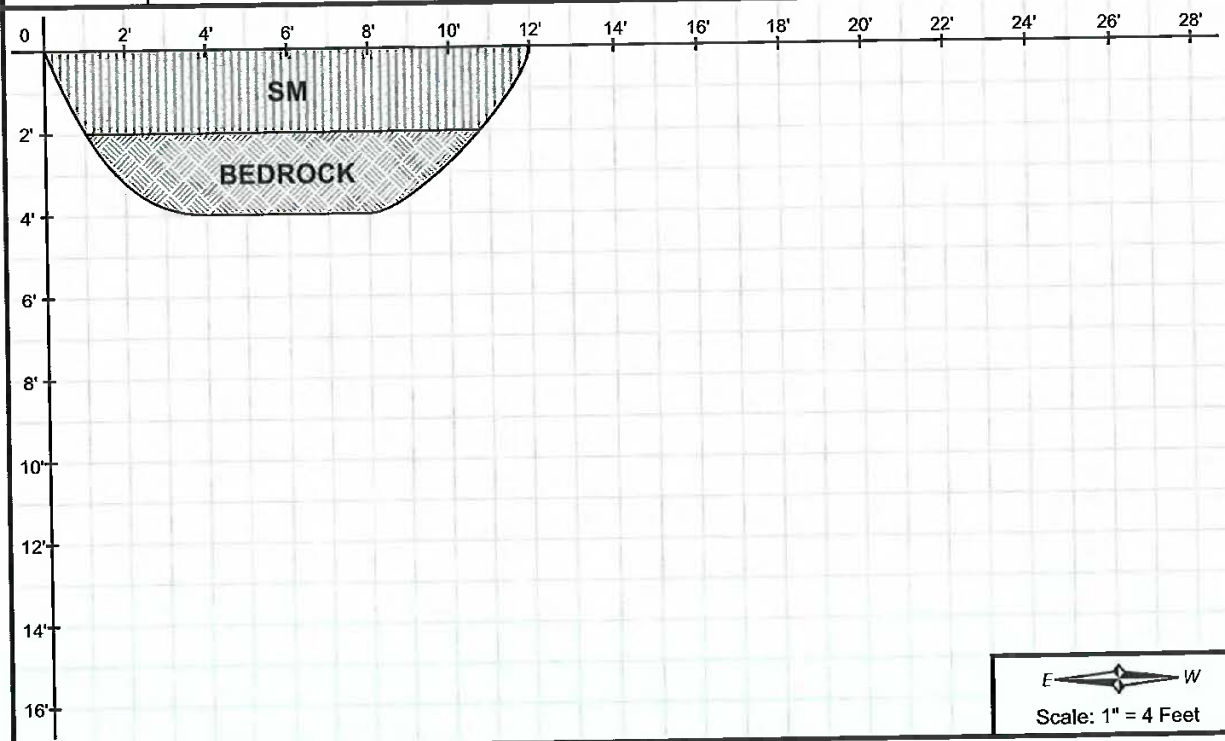

Note: The test pit log indicates subsurface conditions only at the specific location and time noted. Subsurface conditions, including groundwater levels, at other locations of the subject site may differ significantly from conditions which, in the opinion of Youngdahl Consulting Group, Inc., exist at the sampling locations. Note, too, that the passage of time may affect conditions at the sampling locations.

 YOUNGDAHL CONSULTING GROUP, INC. <small>ESTABLISHED 1984</small>	Project No.: E22014.000	EXPLORATORY TEST PIT LOG Greenwood Estates Cameron Park, California	FIGURE A-4
	March 20222		

Logged By: MAP	Date: 17 January 2022	Lat / Lon: ~N° / ~W°	Pit No. TP-3
Equipment: CAT 303.5E with 12" Bucket	Pit Orientation: N - S	Elevation: ~	

Depth (Feet)	Geotechnical Description & Unified Soil Classification	Sample	Tests & Comments
@ 0' - 2'	Red brown to yellow brown fine sandy SILT (ML) , soft to medium stiff, moist		
@ 2' - 2.5'	Olive to yellow brown fine to medium sandy CLAY (CL) , medium stiff, moist		
@ 2.5' - 3'	Olive to green grey metavolcanic BEDROCK , moderately to highly weathered, closely jointed, moderately hard to hard		
	Test pit terminated at 3' (practical refusal) No free groundwater encountered No caving noted		

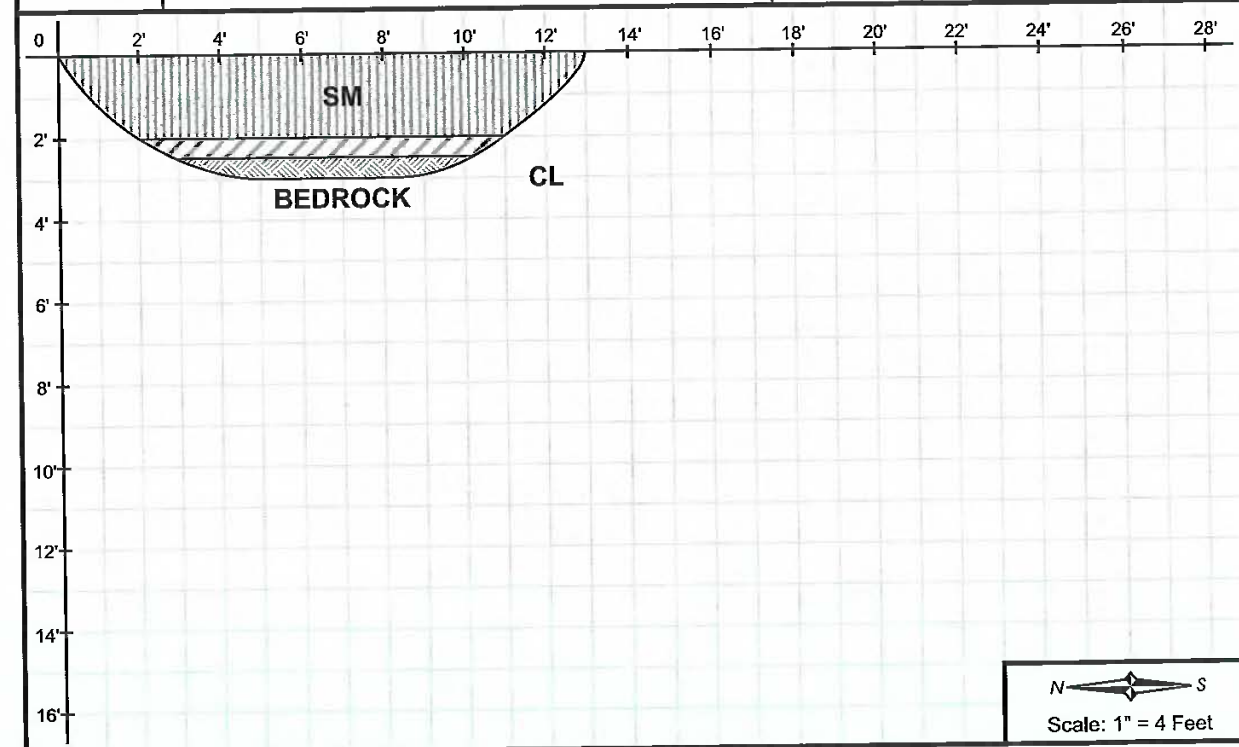

Note: The test pit log indicates subsurface conditions only at the specific location and time noted. Subsurface conditions, including groundwater levels, at other locations of the subject site may differ significantly from conditions which, in the opinion of Youngdahl Consulting Group, Inc., exist at the sampling locations. Note, too, that the passage of time may affect conditions at the sampling locations.

	Project No.: E22014.000	EXPLORATORY TEST PIT LOG Greenwood Estates Cameron Park, California	FIGURE A-5
	March 2022		

Logged By: MAP	Date: 17 January 2022	Lat / Lon: ~N° / ~W°	Pit No. TP-4
Equipment: CAT 303.5E with 12" Bucket	Pit Orientation: E - W	Elevation: ~	

Depth (Feet)	Geotechnical Description & Unified Soil Classification	Sample	Tests & Comments
@ 0' - 2'	Red brown to yellow brown fine sandy SILT (ML) , soft to medium stiff, moist		
@ 2' - 2.5'	Olive to yellow brown fine to medium sandy CLAY (CL) , medium stiff, moist		
@ 2.5' - 4.5'	Olive to green grey metavolcanic BEDROCK , moderately to highly weathered, closely jointed, moderately hard to hard		
	Test pit terminated at 4.5' (practical refusal) No free groundwater encountered No caving noted		

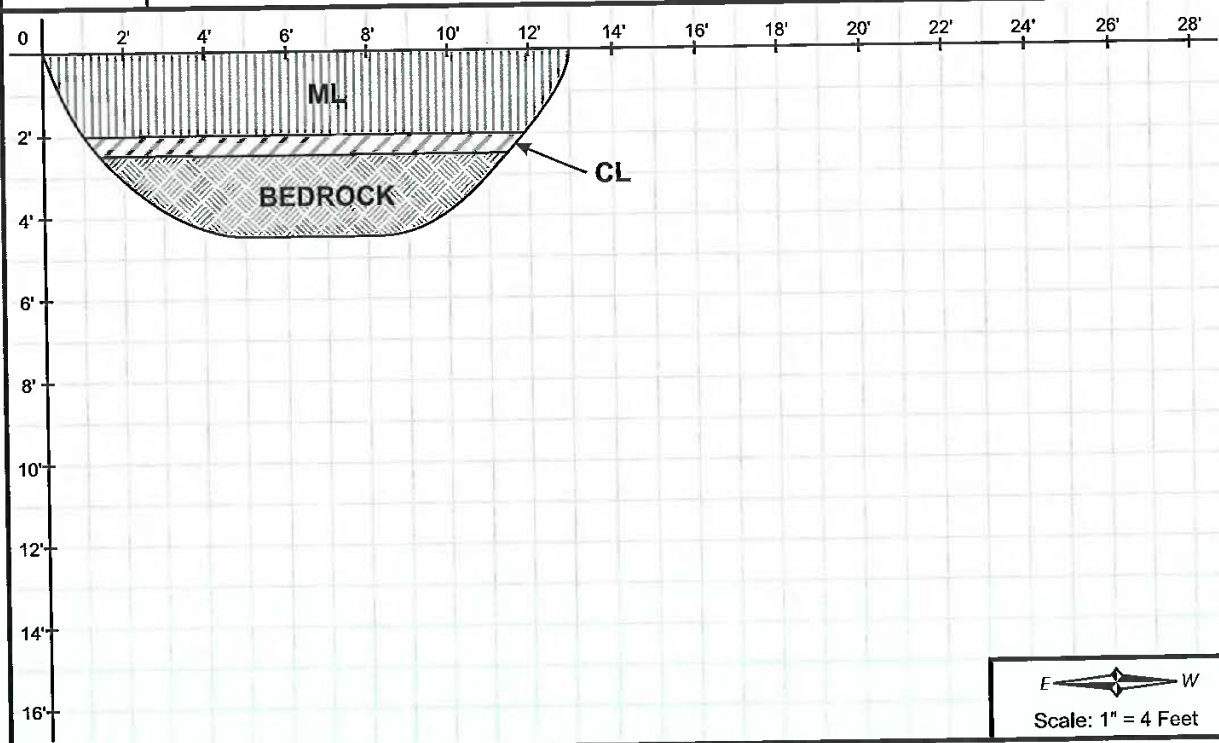

Note: The test pit log indicates subsurface conditions only at the specific location and time noted. Subsurface conditions, including groundwater levels, at other locations of the subject site may differ significantly from conditions which, in the opinion of Youngdahl Consulting Group, Inc., exist at the sampling locations. Note, too, that the passage of time may affect conditions at the sampling locations.

 YOUNGDAHL CONSULTING GROUP, INC. <small>ESTABLISHED 1984</small>	Project No.: E22014.000	EXPLORATORY TEST PIT LOG Greenwood Estates Cameron Park, California	FIGURE A-6
	March 20222		

UNIFIED SOIL CLASSIFICATION SYSTEMS					
MAJOR DIVISION		SYMBOLS	TYPICAL NAMES		
COARSE GRAINED SOILS Over 50% > #200 sieve	GRAVELS Over 50% > #4 sieve	Clean GRAVELS With Little Or No Fines	GW Well graded GRAVELS, GRAVEL-SAND mixtures		
			GP Poorly graded GRAVELS, GRAVEL-SAND mixtures		
		GRAVELS With Over 12% Fines	GM Silty GRAVELS, poorly graded GRAVEL-SAND-SILT mixtures		
			GC Clayey GRAVELS, poorly graded GRAVEL-SAND-CLAY mixtures		
	SANDS Over 50% < #4 sieve	Clean SANDS With Little Or No Fines	SW Well graded SANDS, gravelly SANDS		
			SP Poorly graded SANDS, gravelly SANDS		
		SANDS With Over 12% Fines	SM Silty SANDS, poorly graded SAND-SILT mixtures		
			SC Clayey SANDS, poorly graded SAND-CLAY mixtures		
			FINE GRAINED SOILS Over 50% < #200 sieve	SILTS & CLAYS Liquid Limit < 50	ML Inorganic SILTS, silty or clayey fine SANDS, or clayey SILTS with plasticity
					CL Inorganic CLAYS of low to medium plasticity, gravelly, sandy, or silty CLAYS, lean CLAYS
OL Organic CLAYS and organic silty CLAYS of low plasticity					
SILTS & CLAYS Liquid Limit > 50	MH Inorganic SILTS, micaceous or diatomaceous fine sandy or silty soils, elastic SILTS				
	CH Inorganic CLAYS of high plasticity, fat CLAYS				
	OH Organic CLAYS of medium to high plasticity, organic SILTS				
	HIGHLY ORGANIC CLAYS	PT PEAT & other highly organic soils			

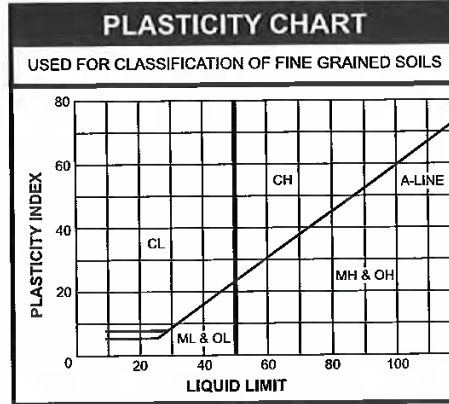

SAMPLE DRIVING RECORD

BLOWS PER FOOT	DESCRIPTION
25	25 Blows drove sampler 12 inches, after initial 6 inches of seating
50/7"	50 Blows drove sampler 7 inches, after initial 6 inches of seating
50/3"	50 Blows drove sampler 3 inches during or after initial 6 inches of seating

Note: To avoid damage to sampling tools, driving is limited to 50 blows per 6 inches during or after seating interval.

SOIL GRAIN SIZE

U.S. STANDARD SIEVE	6"	3"	¾"	4	10	40	200		
	BOULDER	COBBLE	GRAVEL		SAND			SILT	CLAY
			COARSE	FINE	COARSE	MEDIUM	FINE		
SOIL GRAIN SIZE IN MILLIMETERS	150	75	19	4.75	2.0	.425	0.075	0.002	

KEY TO PIT & BORING SYMBOLS		KEY TO PIT & BORING SYMBOLS	
	Standard Penetration test		Joint
	2.5" O.D. Modified California Sampler		Foliation
	3" O.D. Modified California Sampler		Water Seepage
	Shelby Tube Sampler	NFWE	No Free Water Encountered
	2.5" Hand Driven Liner	FWE	Free Water Encountered
	Bulk Sample	REF	Sampling Refusal
	Water Level At Time Of Drilling	DD	Dry Density (pcf)
	Water Level After Time Of Drilling	MC	Moisture Content (%)
	Perched Water	LL	Liquid Limit
		PI	Plasticity Index
		PP	Pocket Penetrometer
		UCC	Unconfined Compression (ASTM D2166)
		TVS	Pocket Torvane Shear
		EI	Expansion Index (ASTM D4829)
		Su	Undrained Shear Strength

YOUNGDAHL CONSULTING GROUP, INC. <small>ESTABLISHED 1984</small>	Project No.: E22014.000	SOIL CLASSIFICATION CHART AND LOG EXPLANATION Greenwood Estates Cameron Park, California	FIGURE A-7
	March 2022		

APPENDIX B
Laboratory Testing

Direct Shear Test
Modified Proctor Test
R-Value Test
Corrosivity Tests

Direct Shear Test of Soils Under Consolidated Drained Conditions, ASTM D3080

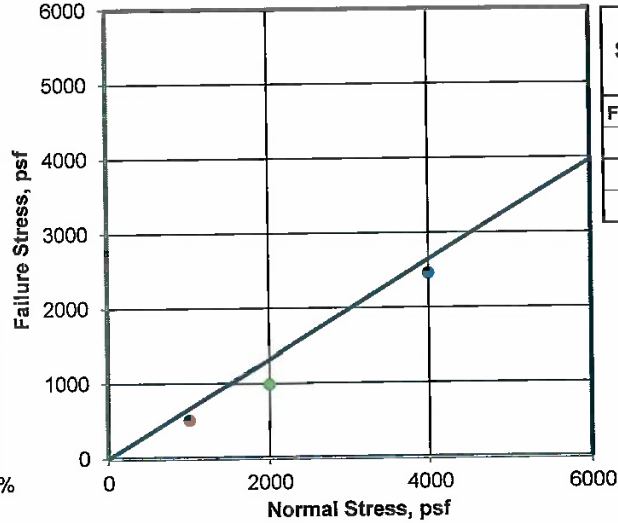
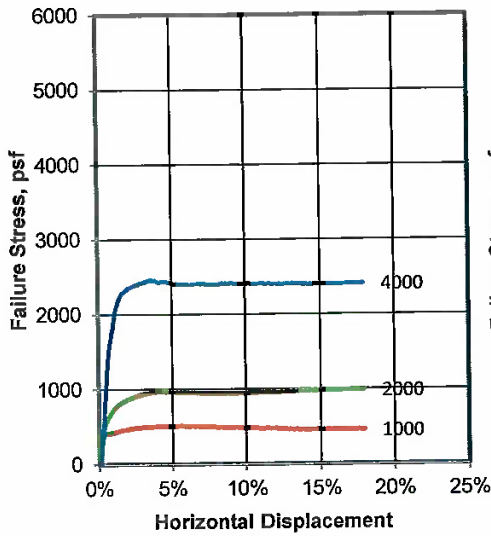

Direct Shearbox Results	
Friction Angle	33.5°
Cohesion	0 psf

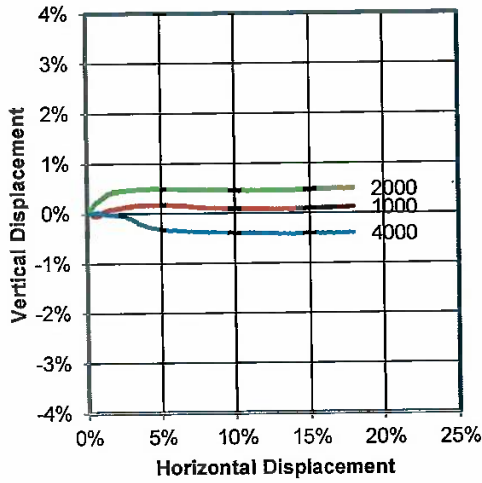

Test No.	1	2	3	
Initial	Wet Density, pcf	120.8	120.8	120.8
	Dry Density, pcf	107.9	107.9	107.9
	Moisture Content, %	11.9	11.9	11.9
	Diameter, in	2.50	2.50	2.50
	Height, in	1.00	1.00	1.00
Pre Shear	Wet Density, pcf	132.0	135.8	132.2
	Dry Density, pcf	108.7	112.2	110.8
	Moisture Content, %*	21.5	21.1	19.3
	Diameter, in	2.50	2.50	2.50
	Height, in	0.99	0.96	0.97
Normal Stress, psf	1000	2000	4000	
Failure Stress, psf	512	993	2460	
Failure Strain, %	5.57	17.59	3.65	
Rate, in/min	0.002			

*Based on post shear moisture content

Sample Type: Remolded to 90% RC

Material Description: Brown Sandy SILT with Gravel

Source:

Notes: Gravel removed from test sample.

Sample No./Depth:	USCS Class.	Liquid Limit	Plasticity Index	% Greater than No. 4	% Less than No. 200
Composite of TP-1, 2, 3, and 4 @ 0-2'				6	

Date Sampled: 1/17/2022 Date Test Started: 2/15/2022



1234 Glenhaven Court, El Dorado Hills, CA 95762
 ph 916.933.0633 ▪ fx 916.933.6482 ▪ www.youngdahl.net

Project: Greenwood Estates GES

Project No.: E22014.000

Reviewed By: DN Date: 2/18/2022

Figure

B-1

**Laboratory Compaction Characteristics of Soil
Using Modified Effort (56,000 lbf-ft³), ASTM D1557, Method A**

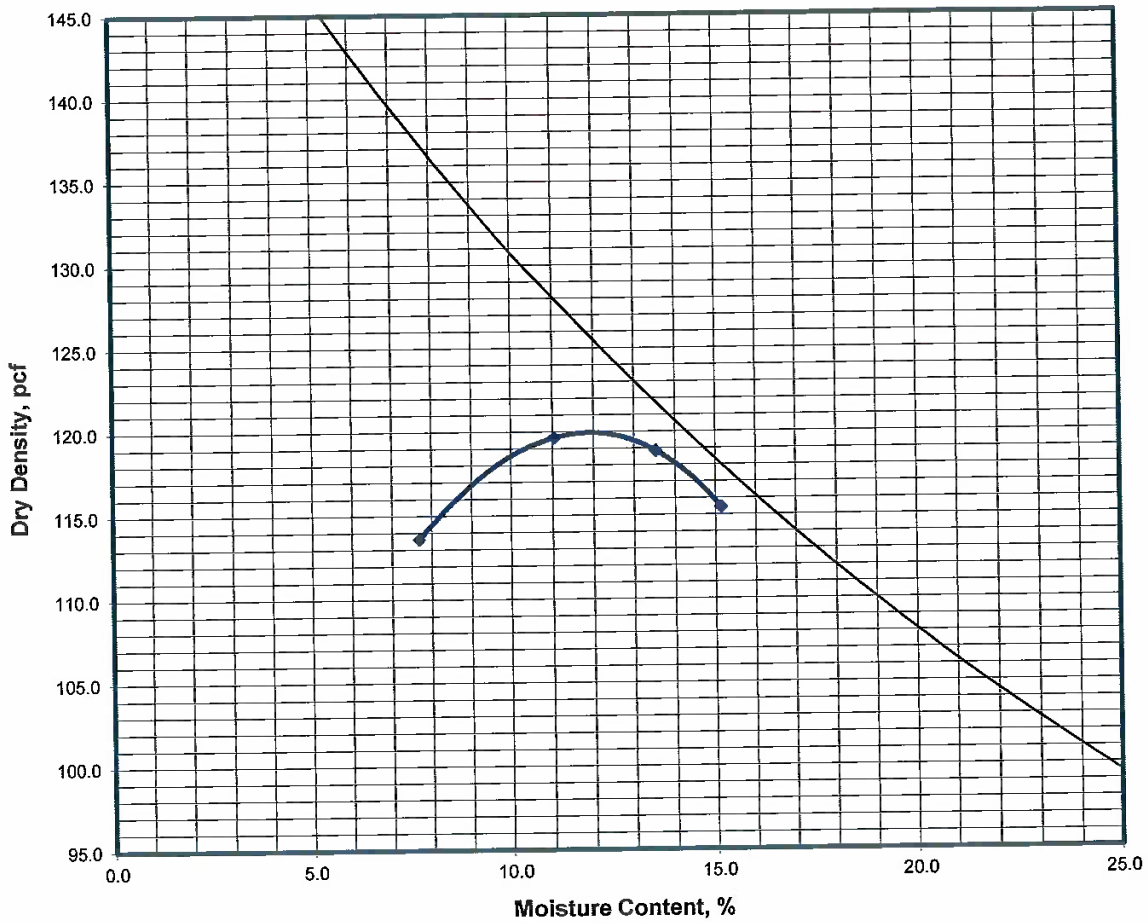

— Zero Air Voids Curve at 100% Saturation;
Specific Gravity Estimated at: 2.65

Maximum Dry Density, pcf: 119.9		Optimum Moisture Content, %: 11.9			
Material Description: Brown Sandy SILT with Gravel					
Source: Composite of TP-1, 2, 3, and 4					
Notes:					
Sample No./Depth: Curve 1	USCS Class.	Liquid Limit	Plasticity Index	% Greater than No. 4: 6	% Less than No. 200
Date Sampled: 1/17/2022	Date Test Started: 1/26/2022				
 YOUNGDAHL CONSULTING GROUP, INC. <small>ESTABLISHED 1984</small> 1234 Glenhaven Court, El Dorado Hills, CA 95762 ph 916.933.0633 ▪ fx 916.933.6482 ▪ www.youngdahl.net		Project: Greenwood Estates GES		Figure	
		Project No.: E22014.000		B-2	
		Reviewed By: JGR	Date: 1/27/2022		

Resistance "R" Value of Soil and Soil-Aggregate Mixtures, CTM 301

R- Value Chart

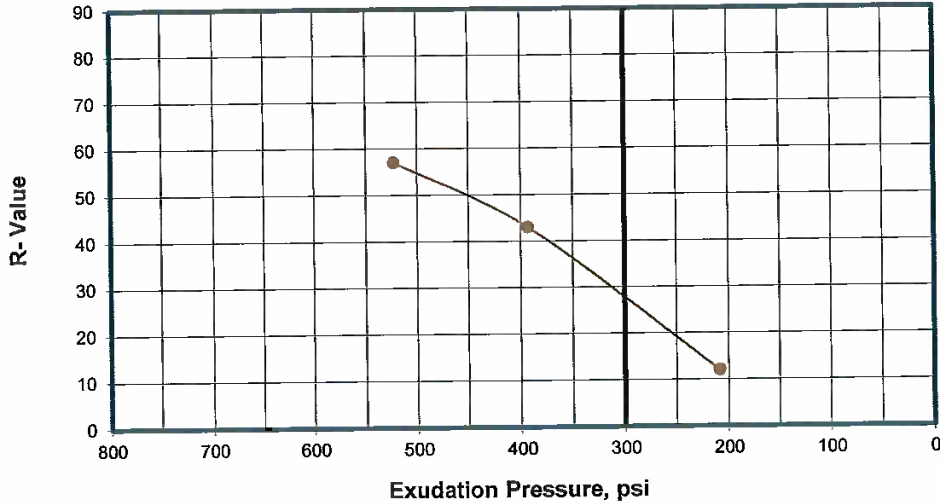

Test Specimen No.:	1	2	3
Moisture Content at Test, %	14.2	15.3	17.3
Dry Density at Test, pcf	119.3	117.2	112.4
Expansion Pressure, psf	147	130	30
Exudation Pressure, psi	523	394	208
Resistance "R" Value	57	43	12
"R" Value at 300 psi Exudation Pressure			28

Material Description: **Brown Sandy SILT with Gravel**

Source:

Notes:

Sample No./Depth:	Composite of TP-1, 2, 3, & 4 @ 0-2	USCS Class.	Liquid Limit	Plasticity Index	% Greater than No. 4	% Less than No. 200
Date Sampled:	1/17/2022	Date Test Started:	2/8/2022		6	



1234 Glenhaven Court, El Dorado Hills, CA 95762
 ph 916.933.0633 ▪ fx 916.933.6482 ▪ www.youngdahl.net

Project: **Greenwood Estates**

Project No.: **E22014.000**

Reviewed By: JLC

Date: 2/9/2022

Figure

B-3



Sunland Analytical

11419 Sunrise Gold Circle, #10
Rancho Cordova, CA 95742
(916) 852-8557

RECEIVED JAN 31 2022

Date Reported 01/26/2022
Date Submitted 01/19/2022

To: Jeffry Cannon
Youngdahl Consulting Group
1234 Glenhaven Ct.
El Dorado Hills, CA 95630

From: Gene Oliphant, Ph.D. \ Randy Horney
General Manager \ Lab Manager

The reported analysis was requested for the following location:
Location : E22014.000 GREENWOOD Site ID : BLK1 TP1,2 @0-2.
Thank you for your business.

* For future reference to this analysis please use SUN # 86480-180105.

EVALUATION FOR SOIL CORROSION

Soil pH	6.19		
Minimum Resistivity	3.22	ohm-cm (x1000)	
Chloride	1.7 ppm	00.00017	%
Sulfate	9.3 ppm	00.00093	%

METHODS

pH and Min. Resistivity CA DOT Test #643
Sulfate CA DOT Test #417; Chloride CA DOT Test #422m



Sunland Analytical

11419 Sunrise Gold Circle, #10
Rancho Cordova, CA 95742
(916) 852-8557

Date Reported 01/26/2022
Date Submitted 01/19/2022

To: Jeffry Cannon
Youngdahl Consulting Group
1234 Glenhaven Ct.
El Dorado Hills, CA 95630

From: Gene Oliphant, Ph.D. \ Randy Horney
General Manager \ Lab Manager

The reported analysis was requested for the following location:
Location : E22014.000 GREENWOOD Site ID : BLK2 TP3,4@ 0-2.
Thank you for your business.

* For future reference to this analysis please use SUN # 86480-180106.

EVALUATION FOR SOIL CORROSION

Soil pH	5.98		
Minimum Resistivity	4.56	ohm-cm (x1000)	
Chloride	2.7	ppm	00.00027 %
Sulfate	6.0	ppm	00.00060 %

METHODS

pH and Min.Resistivity CA DOT Test #643
Sulfate CA DOT Test #417, Chloride CA DOT Test #422m

APPENDIX C
Details

Keyway and Bench with Drain
Site Wall Drainage

PLACEMENT OF FILL ON NATURAL SLOPE (Typical)

All keyways should be observed and approved prior to placement of fill.
A keyway is required by CBC for fills on natural slopes of 5H:1V or steeper.

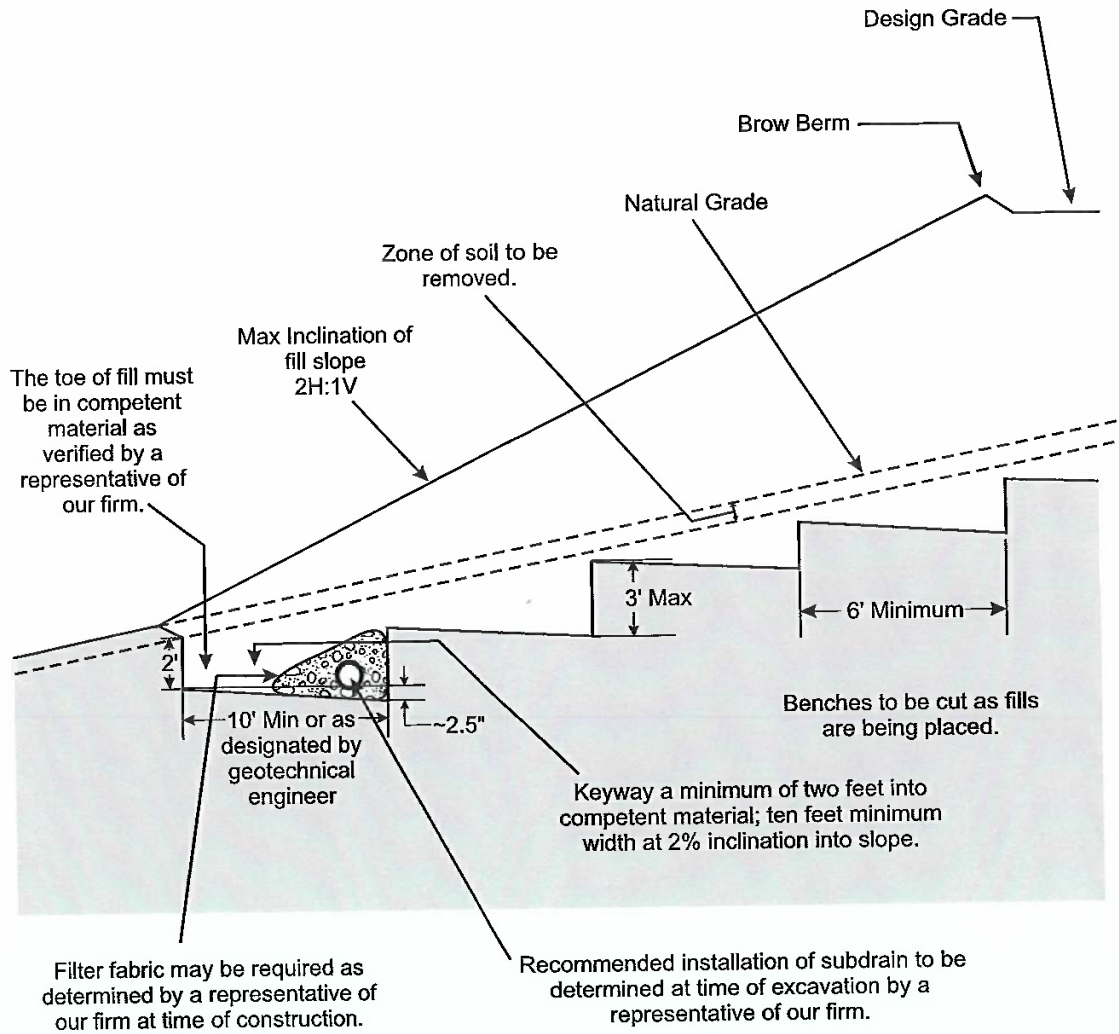

Retaining Wall With "Perforated Pipe Sub-Drain" (Typical Cross Section)

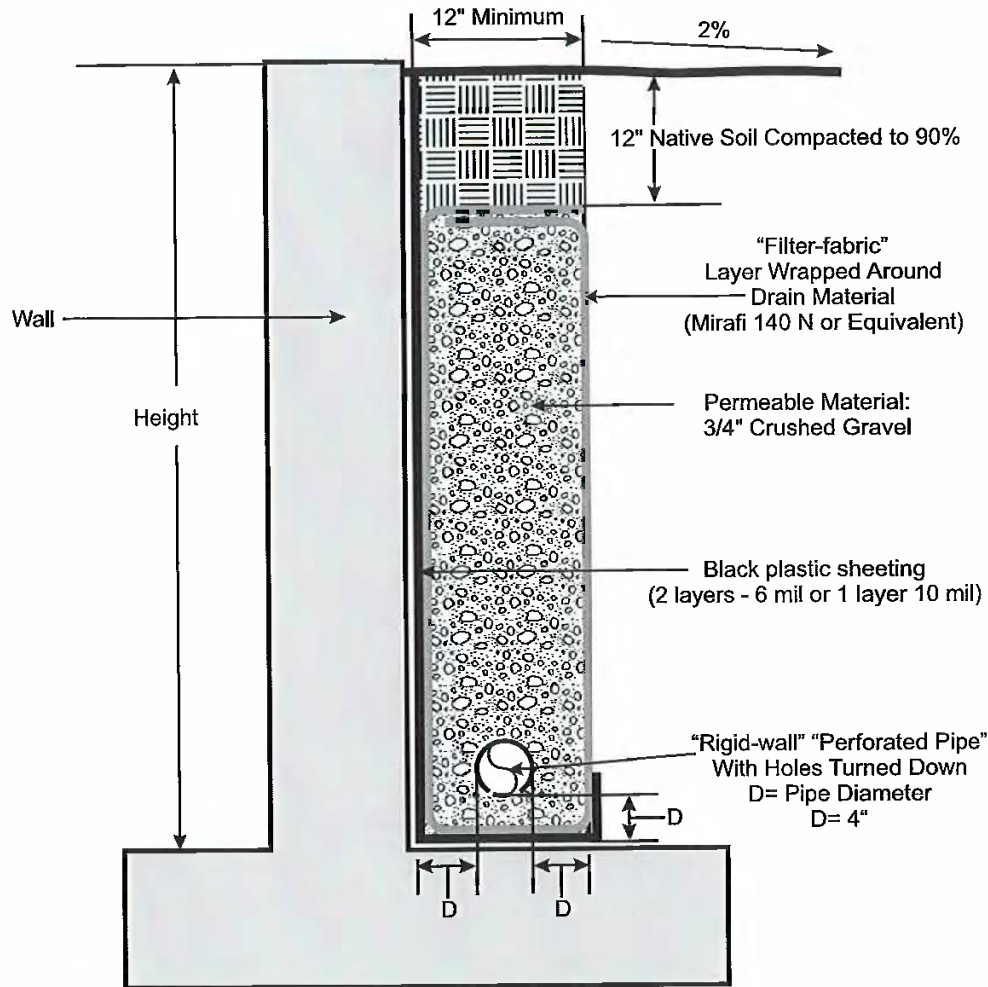

- Notes:
1. Slope trench and "rigid-wall" pipes at least 1% gradient to drain to an appropriate outfall area away from residence.
 2. Use "sweeps" for directional changes in pipe flow (**do not use 90°elbows**).
 3. Provide periodic "clean-outs".
 4. Washed clean permeable material.

Not To Scale

 <p style="font-size: small;">GEOTECHNICAL • ENVIRONMENTAL • MATERIALS TESTING</p>	Project No.: E22014.000	RETAINING WALL DRAIN DETAIL	FIGURE
	February 2022	Greenwood Estates Cameron Park, California	C-2

APPENDIX D
NOA Results

Chain of Custody
Results of Laboratory Testing



Forensic Analytical LABORATORIES

Analysis Request Form (COC)

Client Name & Address: Youngdahl Consulting Group, Inc. 1234 Glenhaven Court El Dorado Hills, CA 95762		Client No.:	PO / Job#: E22014.000	Date: 1 March 2022
Contact: E-mails: map@youngdahl.net		Phone: (916) 933-0633	Turn Around Time: Same Day / 1Day / 2Day 3Day / 4Day / 5Day	
Site Name: Greenwood Estates		<input type="checkbox"/> PCM: <input type="checkbox"/> NIOSH 7400A / <input type="checkbox"/> NIOSH 7400B <input type="checkbox"/> Rotometer		
Site Location: 2545 Greenwood Lane, Cameron Park, California		<input type="checkbox"/> PLM: <input type="checkbox"/> Standard / <input checked="" type="checkbox"/> Point Count 400 1000 / <input checked="" type="checkbox"/> CARB 435		
Comments:		<input type="checkbox"/> TEM Air: <input type="checkbox"/> AHERA / <input type="checkbox"/> Yamate2 / <input type="checkbox"/> NIOSH 7402 <input type="checkbox"/> TEM Bulk: <input type="checkbox"/> Quantitative / <input type="checkbox"/> Qualitative / <input type="checkbox"/> Chatfield <input type="checkbox"/> TEM Water: <input type="checkbox"/> Potable / <input type="checkbox"/> Non-Potable / <input type="checkbox"/> Weight % <input type="checkbox"/> TEM Microvac: <input type="checkbox"/> Qual / <input type="checkbox"/> D5755(str/area) / <input type="checkbox"/> D5756(str/mass)		
IAQ Particle Identification (PLM LAB)		<input type="checkbox"/> PLM Opaques/Soot		
Particle Identification (TEM LAB)		<input type="checkbox"/> Special Project		
Metals Analysis Matrix:		Method:		
Analytes:				

Silica in Air w/Gravimetry
 Quartz Only

Sample ID	Date / Time	Sample Location / Description	FOR AIR SAMPLES ONLY				Sample Area / Air Volume
			Type	Time On/Off	Avg LPM	Total Time	
Sample #1	3/1/22 10:30	Test pits 1 and 2 on the east side of the property 0-4 feet	A P C				
Sample #2	3/1/22 10:45	Test pits 3 and 4 on the west side of the property 0-4 feet	A P C				
			A P C				
			A P C				
			A P C				
			A P C				
			A P C				
			A P C				
			A P C				

Sampled By: Mitchell Perigo Date/Time: 3/1/22 10:30 Shipped Via: Fed Ex UPS US Mail Courier Drop Off Other:

Relinquished By: Mitchell Perigo Date / Time: 3/1/22 12:00	Relinquished By: Date / Time:	Relinquished By: Date / Time:
Received By: Date / Time: Condition Acceptable? <input type="checkbox"/> Yes <input type="checkbox"/> No	Received By: Date / Time: Condition Acceptable? <input type="checkbox"/> Yes <input type="checkbox"/> No	Received By: Date / Time: Condition Acceptable? <input type="checkbox"/> Yes <input type="checkbox"/> No

Forensic Analytical Laboratories may subcontract client samples to other FALJ locations to meet client requests.
 San Francisco Office: 3777 Depot Road, Suite 409, Hayward, CA 94545-2761 • Phone: 510/887-8828 • 800/827-3274
 Los Angeles Office: 2959 Pacific Commerce Drive, Rancho Dominguez, CA 90221 • Phone: 310/763-2374 • 888/813-9417
 Las Vegas Office: 6765 S. Eastern Avenue, Suite 3, Las Vegas, NV 89119 • Phone: 702/784-0040

RECEIVED
 MAR 02 2022
 BY: SVR FX-0624 11:30



Bulk Asbestos Material Analysis

(Air Resources Board Method 435, June 6, 1991)

Youngdahl & Associates, Inc.
David Sederquist
1234 Glenhaven Court

El Dorado Hills, CA 95762

Client ID: 3691
Report Number: N014499
Date Received: 03/02/22
Date Analyzed: 03/07/22
Date Printed: 03/07/22

Job ID/Site: E22014.000 - Greenwood Estates, 2545 Greenwood Lane, Cameron Park

SGSFL Job ID: 3691
Total Samples Submitted: 2
Total Samples Analyzed: 2

PLM Report Number: N/A

Sample Preparation and Analysis:

Samples were analyzed by the Air Resources Board's Method 435, Determination of Asbestos Content of Serpentine Aggregate. Samples were ground to 200 particle size in the laboratory. Approximately 1 pint was retained for analysis. Samples were prepared for observation according to the guidelines of Exception I and Exception II as defined by the 435 Method. Samples which contained less than 10% asbestos were prepared for observation according to the point count technique as defined by the 435 Method. This analysis was performed with a standard cross-hair reticle.

Sample ID	Lab Number	Layer Description
Sample #1	12537417	Brown Soil
<i>Visual Estimation Results:</i>		
Matrix percentage of entire	100	
Visual estimation percentage:	None Detected	
Asbestos type(s) detected:	None Detected	
Comment: This result meets the requirements of Exception I as defined by the 435 Method.		
Sample #2	12537418	Brown Soil
<i>Visual Estimation Results:</i>		
Matrix percentage of entire	100	
Visual estimation percentage:	None Detected	
Asbestos type(s) detected:	None Detected	
Comment: This result meets the requirements of Exception I as defined by the 435 Method.		

Tad Thrower, Laboratory Supervisor, Hayward Laboratory

Note: Limit of Quantification (LOQ) = 0.25%. Trace denotes the presence of asbestos below the LOQ. ND = None Detected. Analytical results and reports are generated by SGS Forensic Laboratories (SGSFL) at the request of and for the exclusive use of the person or entity (client) named on such report. Results, reports or copies of same will not be released by SGSFL to any third party without prior written request from client. This report applies only to the sample(s) tested. Supporting laboratory documentation is available upon request. This report must not be reproduced except in full, unless approved by SGSFL. The client is solely responsible for the use and interpretation of test results and reports requested from SGSFL. SGSFL is not able to assess the degree of hazard resulting from materials analyzed. SGS Forensic Laboratories reserves the right to dispose of all samples after a period of thirty (30) days, according to all state and federal guidelines, unless otherwise specified. All samples were received in acceptable condition unless otherwise noted.

2021 OCT 22 AM 8:11
RECEIVED
PLANNING DEPARTMENT

PRELIMINARY DRAINAGE REPORT
For
GREENWOOD ESTATES
TM, PD & REZONE
CAMERON PARK, CA

B.
Lebeck

REGISTERED PROFESSIONAL ENGINEER
BARBARA A. LEBECK
No. 47045
exp. 12-31-21
CIVIL
STATE OF CALIFORNIA

Digitally signed by B. Lebeck
DN: cn=B. Lebeck, o=Lebeck
Engineering, Inc., ou,
email=bobbie@lebeckeng.co
m, c=US
Date: 2021.09.25 16:02:23
+07'00'



LEBECK

ENGINEERING, INC.

3430 Robin Lane, Bldg.#2, Cameron Park, CA 95682
(530) 677-4080
e-mail: bobbie@lebeckeng.com

By: B. Lebeck, P.E.
September 2021

FILE C077

Z21-0012/PD21-0003/TM21-0001

Vicinity Map

2545 Greenwood Lane, Cameron Park, CA 95682
Lot 46, Cameron Park North, Unit No. 5
APN: 082-411-004 - El Dorado County, CA
August 2021

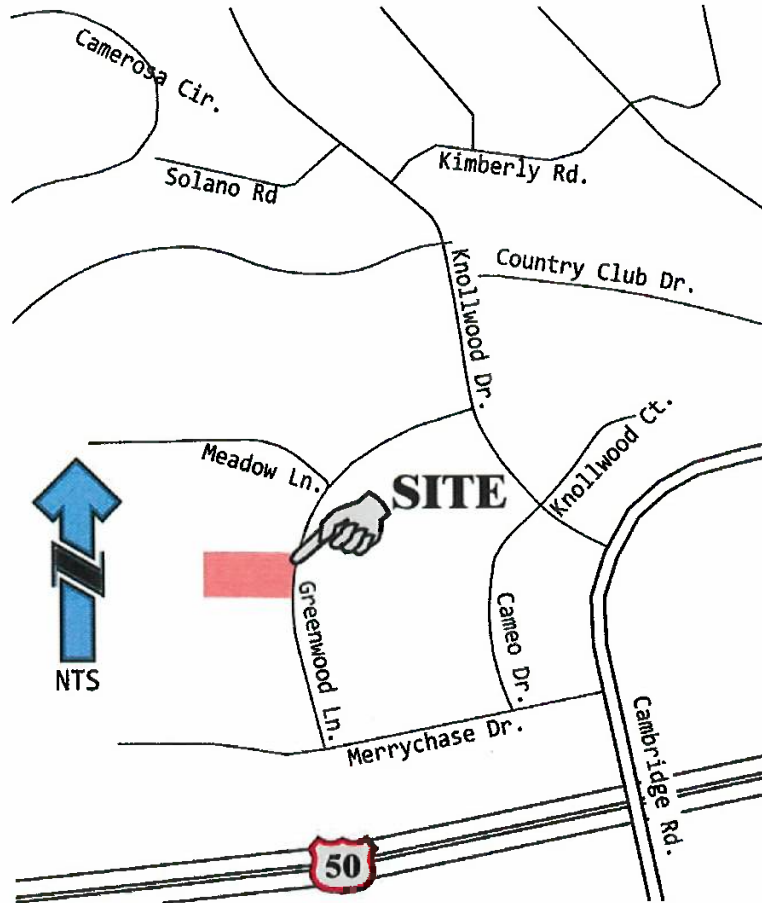

NOT TO SCALE

NAME OF APPLICANT:
Cameron Glen Estates, LLC
c/o Joe Jaoudi
2216 Via Subria
Vista, CA 92084
760-664-7196
josjoudi@aol.com

OWNER OF RECORD:
Cameron Glen Estates, LLC
c/o Joe Jaoudi
2216 Via Subria
Vista, CA 92084
760-664-7196
josjoudi@aol.com



**LEBECK
ENGINEERING, INC.**

3430 ROBIN LANE, BLDG. #2
CAMERON PARK, CA 95682
Ph. (530) 677-4080

s

**Preliminary Drainage Report for
Greenwood Estates – TM, PD, & Rezone
Greenwood Drive, Cameron Park, CA:**

INTRODUCTION AND BACKGROUND

This property is located on the westerly side of Greenwood Lane in Cameron Park, California, approximately 1/3 mile northwest of Highway 50 at the Cambridge Road Exit. The property is an existing 0.88 acre lot that is currently vacant. The site is covered with grasses and has a gentle, up-slope from east to west. The site lies to the east and adjacent to Camerado Springs Middle School's ballfield. To the north is another vacant parcel. To the south is an existing apartment project, called Camerado Gardens. Across the street are several vacant parcels and some existing commercial lies to the northeast.

The site and surrounding areas were analyzed in 2 existing drainage reports: Cameron Park Watershed Area Study – July 1985 prepared by the Soil Conservation Service; and the more recent "Cameron Park Drainage Study – June 1995 prepared by Psomas & Associates. For the purposes of this report, we will be referring to the later as the more recent report covering the area. Applicable portions of the Cameron Park Drainage Study are included in the Appendix. Since this project area is part of the previous drainage report, our Off-site Watershed Exhibit Map , W1 and Watershed Aerial Exhibit Map, W2 show the locations of Watersheds CA-31 and CA-32. It should be noted that due to the more focused analysis of Watershed CA-32 in this report, there are some variations from the 1995 report. However, we feel that our watershed is the more accurate watershed area.

The site and the surrounding areas are covered with grasses, some oaks, and developed properties. The drainage in the area flows from Bass Lake Road to the southeast. The upstream drainage swale is referred to in the Cameron Park Drainage Study as the "Chelsea Reach" and consists of Watersheds CA-26 through CA-32. The project site lies in Watershed CA-32. Watersheds CA-31 and CA-32 combine then flow into combined Watershed CA-26 through CA-30. The resulting intermittent stream then flows south where it crosses Highway 50 and then drains into Deer Creek. The drainage for the site was analyzed using methodology as discussed in the El Dorado County Drainage Manual, adopted March 15, 1995.

HYDROLOGY

- **Methods**

The site was analyzed using peak runoff rates and volumes as determined by the U.S. Army Corp of Engineers Hydraulic Engineering Circular, HEC-HMS program. The HEC-HMS program was used in coordination with the Soil Conservation Service (SCS) Dimensionless Unit Hydrograph Method and the El Dorado County Drainage Manual, adopted March 15, 1995, in order to determine the peak runoff rates for both pre-development and post-development scenarios. The HEC-HMS program is the updated program from HEC-1.

The input data for the HEC-HMS program consists of watershed areas, curve numbers, lag time, channel dimensions, and detention pond data (where applicable). Watershed areas were determined by USGS data in combination with ACAD to determine off-site watershed areas. See Figures W1 and W2 in this report for off-site watershed areas CA-31 and CA-32.

Curve numbers were developed using hydrological soil group data obtained from the 1974 USDA Soils Conservation Service and Forest Service "Soil Survey of El Dorado Area, California" and Exhibit A-1 of the TR-55 manual. Soils are rated as Type A, having high infiltration rates, through Type D, having the lowest infiltration rate. The Soil Survey Map (in the Appendix) was overlaid onto the watershed maps in order to determine the amounts of each soil type present within each watershed area. Curve numbers were then determined using the SCS Worksheet 2 and Tables 2-2a and 2-2c. See Composite Curve Numbers – Pre-Development and Composite Curve Numbers – Post-Development in the Appendix.

Lag time is estimated to be 0.6 times the time of concentration for each sub-basin. The time of concentration for each sub-basin was determined using the SCS method of sheet flow, shallow concentrated flow, and channel flow.

Per Section 2.4 of the EDC Drainage Manual:

- Sheet Flow (L < 300 ft.):

$$T_t = \frac{0.007 (nL)^{0.8}}{(P_2)^{0.5} S^{0.4}} ; L = \text{length of longest watercourse (ft)}$$

$P_2 = 2\text{-yr, 24-hour rainfall depth (in-in)}$
 $S = \text{land slope (ft/ft)}$
 $T_t = \text{sheet flow travel time (hrs)}$
 $n = \text{overland roughness coefficient (per Table 2.4.3)}$
See Appendix)

- **Shallow Concentrated Flow:**

$V = 16.1345 S_o^{0.5}$ (unpaved); V = shallow-concentrated flow velocity (ft./s)

S_o = slope (ft/ft)

$V = 20.3283 S_o^{0.5}$ (paved);

$T_t = L/V$; Travel time is the flow path length divided by the velocity.

- **Channel Flow:**

Velocity is estimated by Manning's Equation, assuming discharge equal the average annual value (2-yr event). The channel flow travel time is the channel length divided by the velocity.

See attached Drainage Calculations Chart for T_t of each drainage area. A minimum time of concentration of 5 minutes was used. The lag time used for each sub-basin along with the determination of the composite curve number used is shown on the Drainage Calculations Chart.

The HEC1 program varies from the SCS TR55 program in that it can be used for larger watersheds and it has a channel routing feature. SCS TR55 is recommended for use on smaller watersheds with a maximum of 10 sub-basins. The channel routing feature of the HEC1 utilized in this analysis was the Muskingum-Cunge routing. With this, a theoretical cross-section of the channel is utilized. Routing schematics for each HEC1 run are located in the Appendix, if applicable.

- **Precipitation**

The mean annual precipitation for the area is 30 inches. The 10-year and 100-year 24-hour precipitation input for the HEC-HMS was determined from page 2-37 and 2-40 of the El Dorado County Drainage Manual.

The project area lies within SCS Type I rainfall distribution. Cumulative precipitation distribution data from TR-20 for a 24-hour SCS Type I storm was used and is shown in the Appendix.

SUMMARY AND CONCLUSIONS:

The HEC-HMS results are as follows:

Watershed	Peak Discharge, Q 10-year (cfs)		Peak Discharge, Q 100-year (cfs)	
	Existing	Developed	Existing	Developed
CA-32	104.1	104.1	165.1	165.1

The results show that there is no increase in the peak discharge for this watershed basin due to the development of this small project. The reason is two-fold. First, the proposed project is less than 1 acre of the 114-acre watershed area (0.8%). Thus the increase in impervious area is small. Second, the soil type of the project site is AwD which is a Type D soil, thus the undeveloped site has a higher curve number than say a type B soil would provide. Therefore, the increased runoff from the developed site is not as great as it would be if the undeveloped site had a more pervious soil type.

Lastly, the site lies at the southerly portion of the overall Chelsea Reach which includes 1,331 acres of tributary area as it crosses Cambridge Road. The peak discharge for this small 0.88-acre site would pass by into Deer Creek long before the entire watershed's peak flows into Deer Creek.

HEC-HMS RESULTS

Project: Jaoudi - Greenwood Simulation Run: 10-yr Exist

Start of Run: 01Jan2021, 00:00 Basin Model: CA-32
End of Run: 03Jan2021, 00:10 Meteorologic Model: 10-yr
Compute Time: 15Sep2021, 15:19:44 Control Specifications:10-yr

Hydrologic Element	Drainage Area (MI ²)	Peak Discharge (CFS)	Time of Peak	Volume (IN)
CA-32	0.1781	104.1	01Jan2021, 10:26	2.62

Subbasin "CA-32" Results for Run "10-yr Exist"

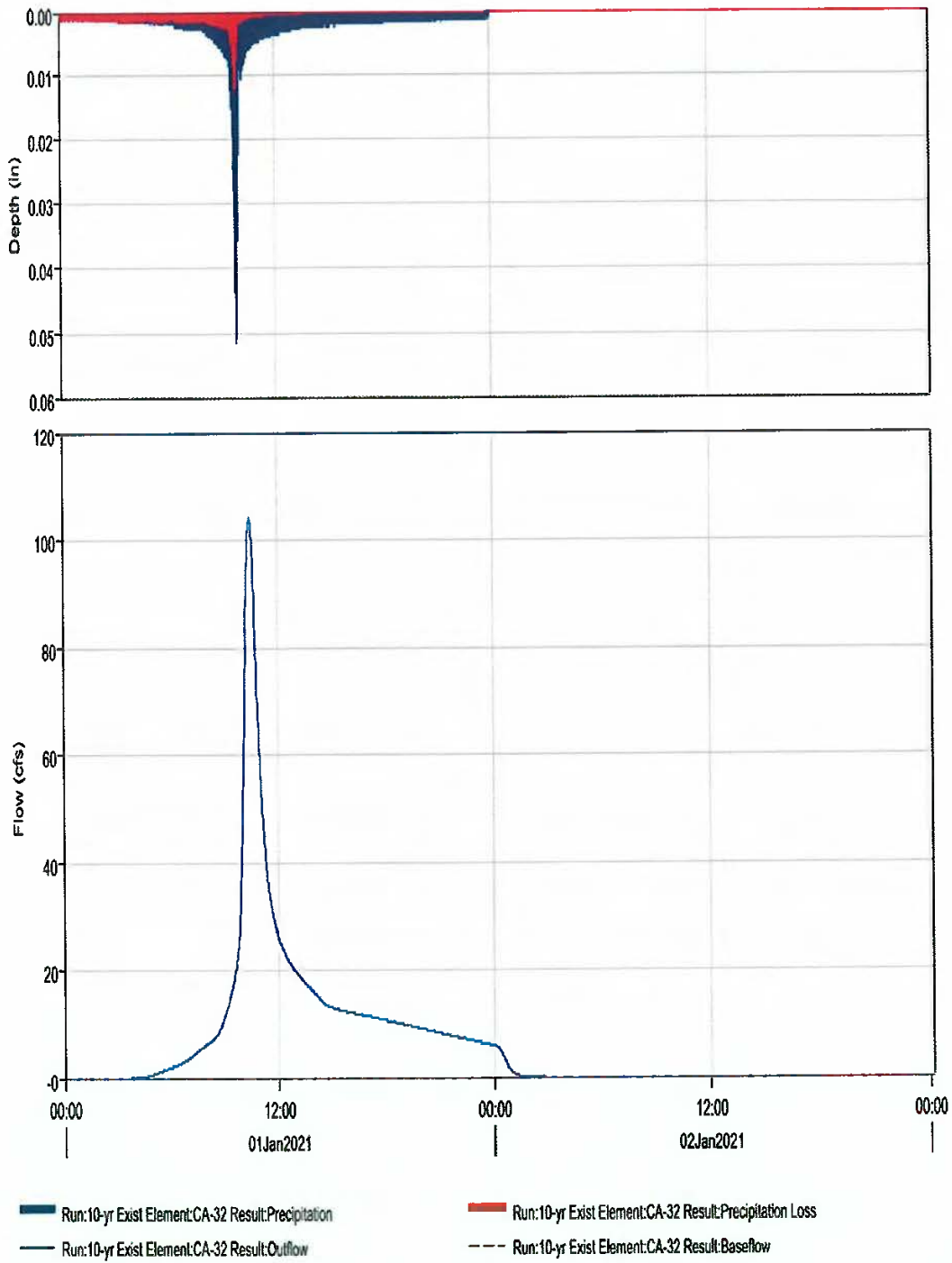

Project: Jaoudi - Greenwood Simulation Run: 10-yr Devel

Start of Run: 01Jan2021, 00:00 Basin Model: CA-32
End of Run: 03Jan2021, 00:10 Meteorologic Model: 10-yr
Compute Time: 15Sep2021, 15:19:36 Control Specifications:10-yr

Hydrologic Element	Drainage Area (MI2)	Peak Discharge (CFS)	Time of Peak	Volume (IN)
CA-32	0.1781	104.1	01Jan2021, 10:26	2.62

Project: Jaoudi - Greenwood Simulation Run: 100-yr Exist

Start of Run: 01Jan2021, 00:00 Basin Model: CA-32
End of Run: 03Jan2021, 00:10 Meteorologic Model: 100-yr
Compute Time: 15Sep2021, 15:20:01 Control Specifications:100-yr

Hydrologic Element	Drainage Area (MI ²)	Peak Discharge (CFS)	Time of Peak	Volume (IN)
CA-32	0.1781	165.1	01Jan2021, 10:26	4.13

Subbasin "CA-32" Results for Run "100-yr Exist"

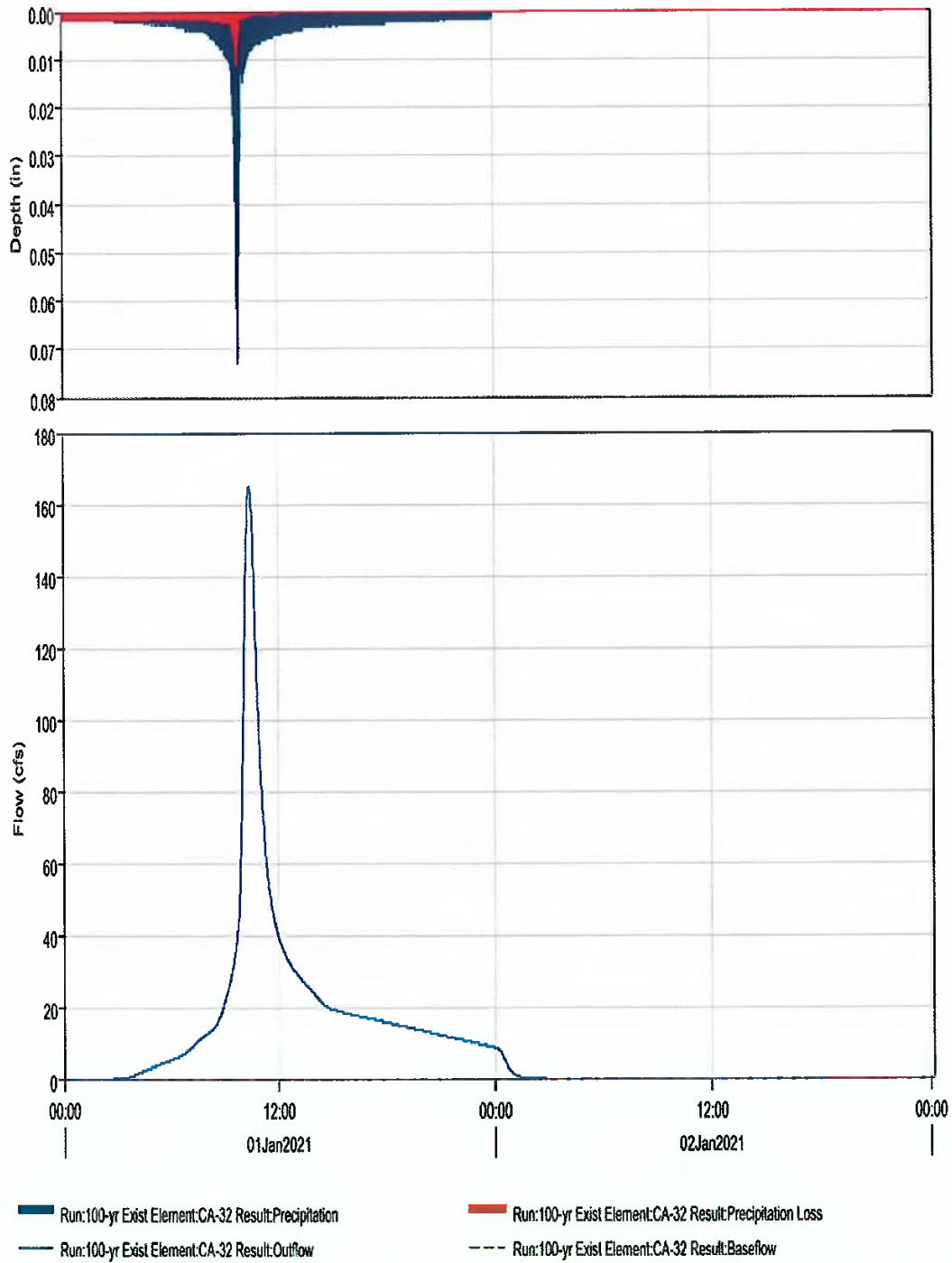

Project: Jaoudi - Greenwood Simulation Run: 100-yr Devel

Start of Run: 01Jan2021, 00:00 Basin Model: CA-32
End of Run: 03Jan2021, 00:10 Meteorologic Model: 100-yr
Compute Time: 15Sep2021, 15:19:52 Control Specifications:100-yr

Hydrologic Element	Drainage Area (MI ²)	Peak Discharge (CFS)	Time of Peak	Volume (IN)
CA-32	0.1781	165.1	01Jan2021, 10:26	4.13

Subbasin "CA-32" Results for Run "10-yr Devel"

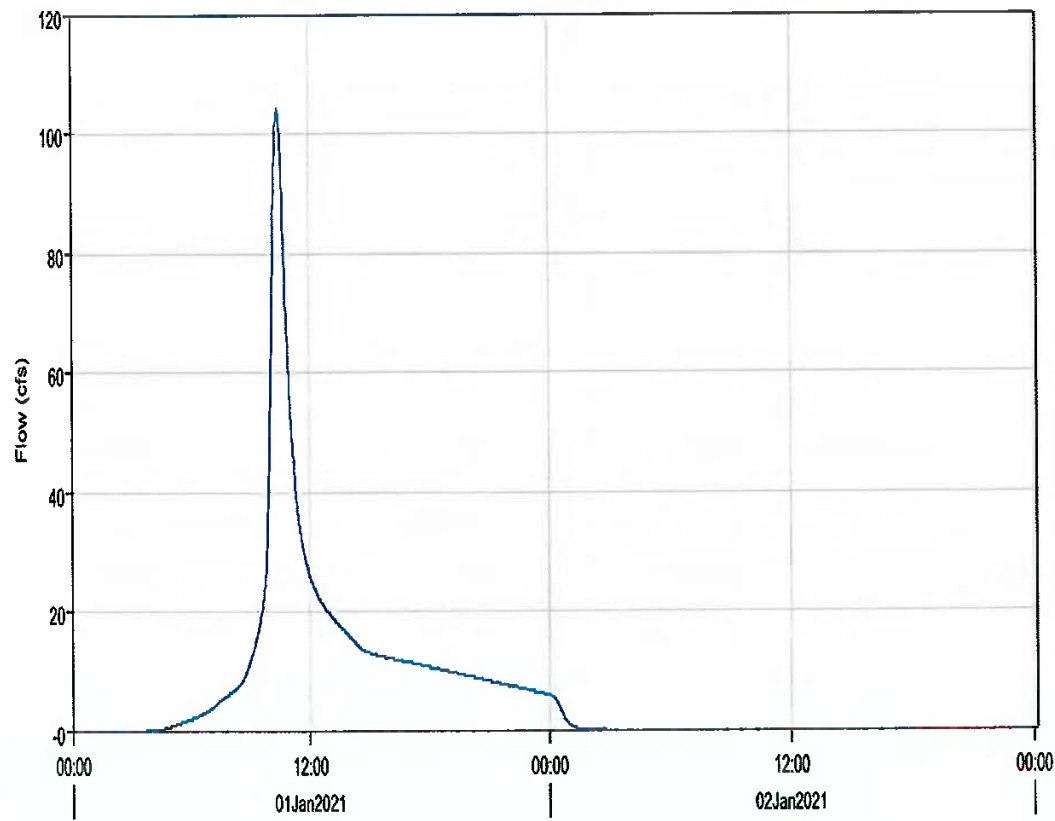
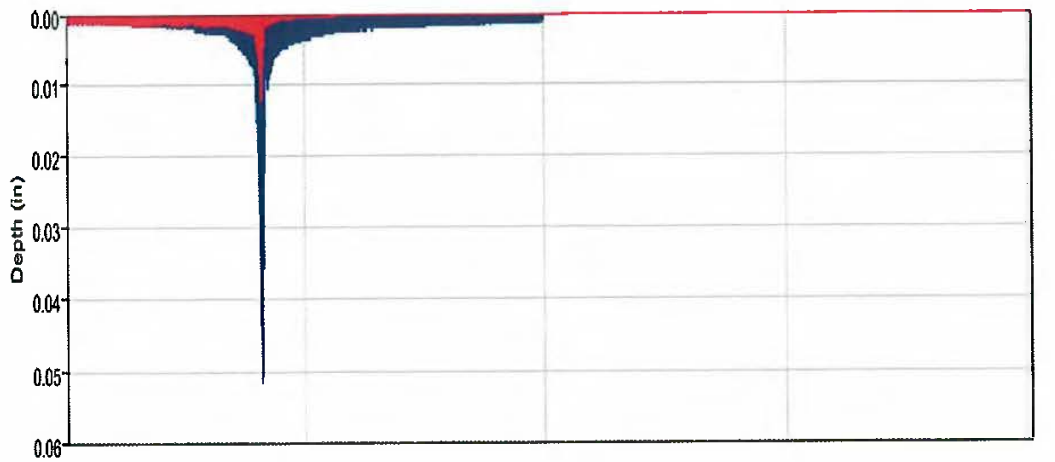

Run:10-yr Devel Element:CA-32 Result:Precipitation
Run:10-yr Devel Element:CA-32 Result:Outflow

Run:10-yr Devel Element:CA-32 Result:Precipitation Loss
Run:10-yr Devel Element:CA-32 Result:Baseflow

Subbasin "CA-32" Results for Run "100-yr Devel"

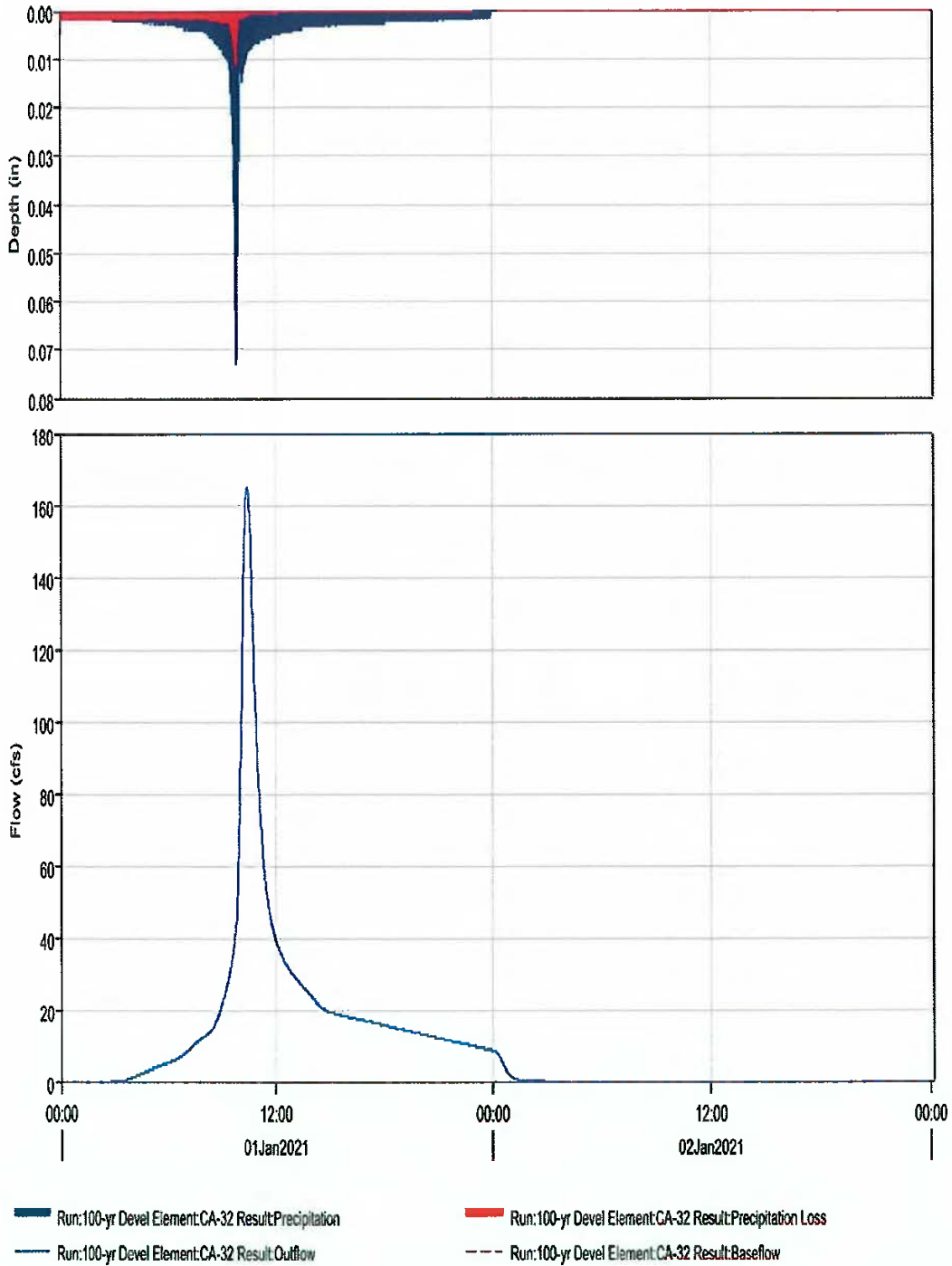

APPENDIX

Existing Uses in Watershed CA-32

Watershed			
CA-32	Existing Uses	Acres	
1	Vacant	14.3	
2	SFR	14	
3	MFR	21.1	
4	Comm'l	14.8	
5	Fields	12.4	
6	Paved/Roads	7.3	
7	Site	0.9	
8	Parks & O.S.	17.4	
9	Schools-Comm'l	11.8	
	Total	114	Acres
Legend:			
SFR	Single Family Residential		
MFR	Multi-Family Residential		
Comm'l	Commercial		
O.S.	Open Space & Drainageways		

1.) COMPOSITE CURVE NUMBERS - PRE-DEVELOPMENT:					
1	Total Watershed Area	114.0	Acres	Hydrological Soil Group	
	<i>AkC, Argonaut gravelly loam</i>	4.6	Acres	D	4%
	<i>AwD, Auburn silt loam</i>	61.4	Acres	D	54%
	<i>AxD, Auburn, very rocky silt loam</i>	20.5	Acres	D	18%
	<i>ReB, Rescue sandy loam</i>	3.9	Acres	B	3%
	<i>SaF, Serpentine rock land</i>	5.1	Acres	-	4%
	<i>SuC, Sobrante silt loam</i>	18.5	Acres	C	16%
	Subtotal	114.0	Acres		
	Land Uses:		Area (Ac)	CN	CN * A
	Vacant	13%	14.3	77	1101.1
	SFR	12%	14.0	86	1204
	MFR	19%	21.1	91	1920.1
	Commercial	13%	14.8	95	1406
	Fields	11%	12.4	83	1029.2
	Paved/Roads	6%	7.3	98	715.4
	Project Site - Existing - grasses	1%	0.9	77	69.3
	Parks & Open Space	15%	17.4	83	1444.2
	Schools - comm'l	10%	11.8	94	1109.2
	Subtotal		114.0		9998.5
	Composite CN =	88			

2.) COMPOSITE CURVE NUMBERS - POST-DEVELOPMENT WATERSHEDS:					
1	Total Watershed Area	114.0	Acres	Hydrological Soil Group	
	AkC, Argonaut gravelly loam	4.6	Acres	D	4%
	AwD, Auburn silt loam	61.4	Acres	D	54%
	AxD, Auburn, very rocky silt loam	20.5	Acres	D	18%
	ReB, Rescue sandy loam	3.9	Acres	B	3%
	SaF, Serpentine rock land	5.1	Acres	-	4%
	SuC, Sobrante silt loam	18.5	Acres	C	16%
	Subtotal	114.0	Acres		
	Land Uses:		Area (Ac)	CN	CN * A
	Vacant	13%	14.3	77	1101.1
	SFR	12%	14.0	86	1204
	MFR	19%	21.1	91	1920.1
	Commercial	13%	14.8	95	1406
	Fields	11%	12.4	83	1029.2
	Paved/Roads	6%	7.3	98	715.4
	Project Site - Developed, MFR	1%	0.9	91	81.9
	Parks & Open Space	15%	17.4	83	1444.2
	Schools - comm'l	10%	11.8	94	1109.2
	Subtotal		114.0		10011.1
	Composite CN =	88			





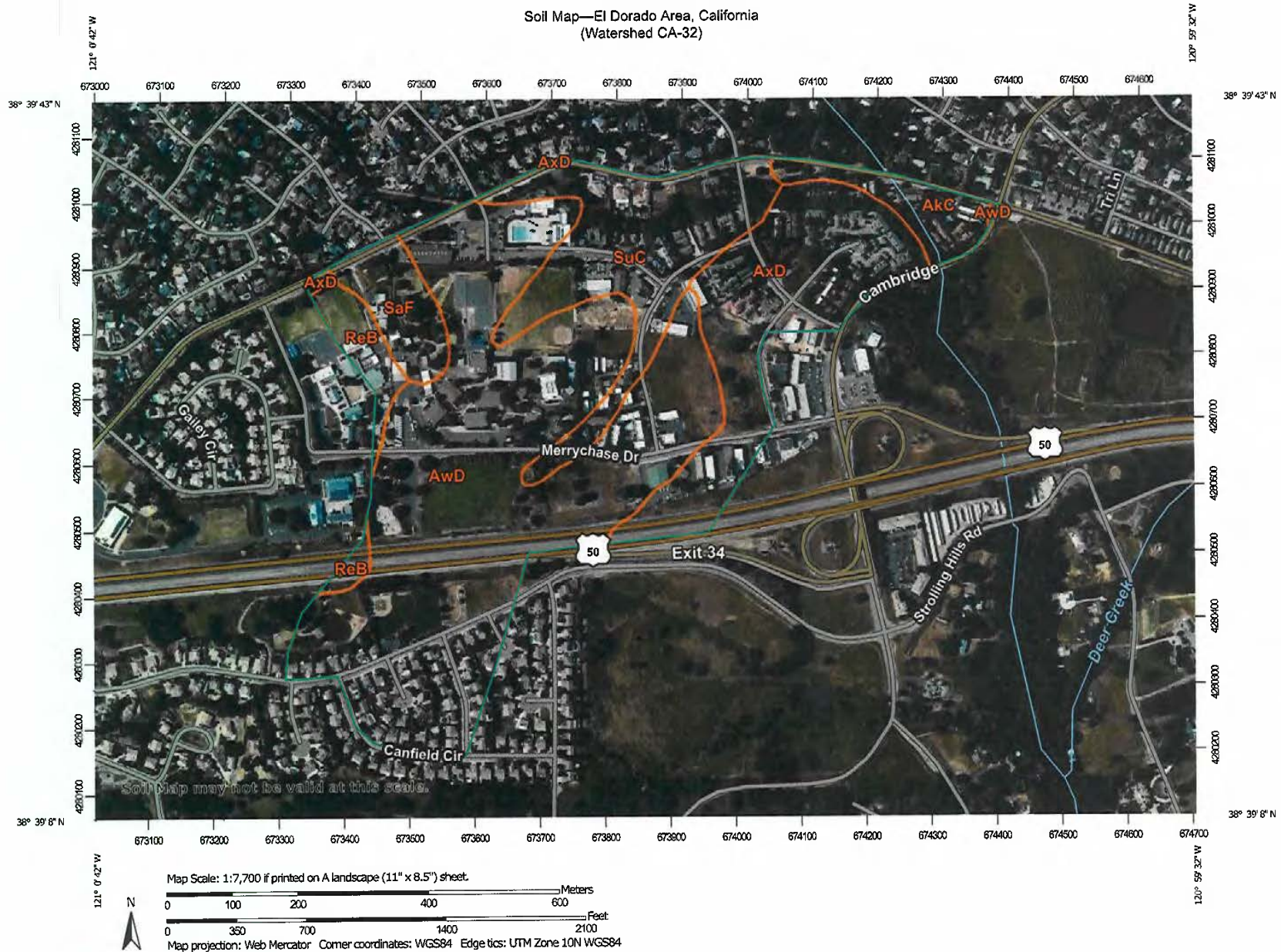































SOIL DATA

Soil Map—El Dorado Area, California
(Watershed CA-32)



Soil Map—El Dorado Area, California
(Watershed CA-32)

MAP LEGEND

- | | | |
|--|--|---|
| Area of Interest (AOI) |  Area of Interest (AOI) |  Spoil Area |
| Soils |  Soil Map Unit Polygons |  Stony Spot |
| |  Soil Map Unit Lines |  Very Stony Spot |
| |  Soil Map Unit Points |  Wet Spot |
| Special Point Features | |  Other |
|  Blowout | |  Special Line Features |
|  Borrow Pit | Water Features |  Streams and Canals |
|  Clay Spot | Transportation |  Rails |
|  Closed Depression | |  Interstate Highways |
|  Gravel Pit | |  US Routes |
|  Gravelly Spot | |  Major Roads |
|  Landfill | |  Local Roads |
|  Lava Flow | Background |  Aerial Photography |
|  Marsh or swamp | | |
|  Mine or Quarry | | |
|  Miscellaneous Water | | |
|  Perennial Water | | |
|  Rock Outcrop | | |
|  Saline Spot | | |
|  Sandy Spot | | |
|  Severely Eroded Spot | | |
|  Sinkhole | | |
|  Slide or Slip | | |
|  Sodic Spot | | |

MAP INFORMATION

The soil surveys that comprise your AOI were mapped at 1:20,000.

Warning: Soil Map may not be valid at this scale.

Enlargement of maps beyond the scale of mapping can cause misunderstanding of the detail of mapping and accuracy of soil line placement. The maps do not show the small areas of contrasting soils that could have been shown at a more detailed scale.

Please rely on the bar scale on each map sheet for map measurements.

Source of Map: Natural Resources Conservation Service
Web Soil Survey URL:
Coordinate System: Web Mercator (EPSG:3857)

Maps from the Web Soil Survey are based on the Web Mercator projection, which preserves direction and shape but distorts distance and area. A projection that preserves area, such as the Albers equal-area conic projection, should be used if more accurate calculations of distance or area are required.

This product is generated from the USDA-NRCS certified data as of the version date(s) listed below.

Soil Survey Area: El Dorado Area, California
Survey Area Data: Version 12, May 29, 2020

Soil map units are labeled (as space allows) for map scales 1:50,000 or larger.

Date(s) aerial images were photographed: May 8, 2019—May 12, 2019

The orthophoto or other base map on which the soil lines were compiled and digitized probably differs from the background imagery displayed on these maps. As a result, some minor shifting of map unit boundaries may be evident.

Map Unit Legend

Map Unit Symbol	Map Unit Name	Acres in AOI		Percent of AOI
AkC	Argonaut gravelly loam, 2 to 15 percent slopes	4.6 Ac	4.8	4.1%
AwD	Auburn silt loam, 2 to 30 percent slopes	61.4 Ac	64.3	53.8%
AxD	Auburn very rocky silt loam, 2 to 30 percent slopes	20.5 Ac.	21.5	18.0%
ReB	Rescue sandy loam, 2 to 9 percent slopes	3.9 Ac.	4.1	3.4%
SaF	Serpentine rock land	5.1 Ac.	5.3	4.5%
SuC	Sobrante silt loam, 3 to 15 percent slopes	18.5 Ac.	19.4	16.2%
Totals for Area of Interest		114 Ac.	119.5	100.0%

In either case, the travel time is the flow path length divided by the velocity.

Channel flow: The velocity of flow in a clearly-defined channel is estimated with Manning's equation, assuming discharge equal the average annual value (2-yr event). If this discharge is unknown, the regression equation presented in Appendix 2.5 can be used to provide an estimate. The channel-flow travel time is the channel length divided by the velocity.

Table 2.4.3 Overland-flow Roughness Coefficients
(Source: SCS, 1986)

Surface description (1)	Overland flow n (2)
Smooth surfaces (concrete, asphalt, gravel, or bare soil)	0.011
Fallow (no residue)	0.05
Cultivated soils:	
Residue cover < 20%	0.06
Residue cover > 20%	0.17
Grass:	
Short grass prairie	0.15
Dense grasses	0.24
Bermuda	0.41
Range (natural)	0.13
Woods:	
Light underbrush	0.40
Dense underbrush	0.80

When the various travel times are determined, t_c can be computed as the sum. The UH lag is estimated as 60% t_c , and Eq. 2.4.5 is solved to find the UH peak. In the solution of Eq. 2.4.6, it is convenient to select ΔD equal the computation time step. Then the resulting UH can be used directly with rainfall excess, which is computed with this same time step, to estimate the runoff hydrograph.

Fig. 2.4.2 shows the 10-min UH developed for an example 5-sq mi catchment in which $t_c = 1$ hr. In that case, lag = 0.60 hr. Solving Eq. 2.4.6 yields $T_p = 0.68$ hr. Eq. 2.4.5 yields $q_p = 3541.5$ cfs/in. of excess rainfall. To develop the UH, values in cols. 1 and 3 of Table 2.4.2 are multiplied by T_p , and the values in cols. 2 and 4 are multiplied by q_p . To compute storm runoff, Eq. 2.4.4 is solved with the UH and excess.

Urban Hydrology for Small Watersheds, US Department of Agriculture, Natural Resources Conservation Service – Technical Release 55

Table 2-2c – Runoff curve numbers for other agricultural lands¹

Cover description		Curve numbers for hydrologic soil group			
Cover type	Hydrologic condition	A	B	C	D
Pasture, grassland, or range-continuous forage for grazing. ²	Poor	68	79	86	89
	Fair	49	69	79	84
	Good	39	61	74	80
Meadow-continuous grass, protected from grazing and generally mowed for hay.	--	30	58	71	78
Brush--brush-weed-grass mixture with brush the major element. ³	Poor	48	67	77	83
	Fair	35	56	70	77
	Good	⁴ 30	48	65	73
Woods--grass combination (orchard or tree farm). ⁵	Poor	57	73	82	86
	Fair	43	65	76	82
	Good	32	58	72	79
Woods. ⁶	Poor	45	66	77	83
	Fair	36	60	73	79
	Good	⁴ 30	55	70	77
Farmsteads--buildings, lanes, driveways, and surrounding lots.	--	59	74	82	86

¹Average runoff condition, and $I_a = 0.25$.

²*Poor:* <50% ground cover or heavily grazed with no mulch.
Fair: 50 to 75% ground cover and not heavily grazed.
Good: >75% ground cover and lightly or only occasionally grazed.

³*Poor:* <50% ground cover.
Fair: 50 to 75% ground cover.
Good: >75% ground cover.

⁴Actual curve number is less than 30: use CN = 30 for runoff computations.

⁵CN's shown were computed for areas with 50% woods and 50% grass (pasture) cover. Other combinations of conditions may be computed from the CN's for woods and pasture.

⁶*Poor:* Forest litter, small trees, and brush are destroyed by heavy grazing or regular burning.
Fair: Woods are grazed but not burned, and some forest litter covers the soil.
Good: Woods are protected from grazing, and litter and brush adequately cover the soil.

Urban Hydrology for Small Watersheds, US Department of Agriculture, Natural Resources Conservation Service – Technical Release 55

Table 2-2a. – Runoff curve numbers for urban areas¹

Cover description	Curve numbers for hydrologic soil group -			
	A	B	C	D
Cover type and hydrologic condition				
<i>Fully developed urban areas (vegetation established)</i>				
Open space (lawns, parks, golf courses, cemeteries, etc.) ³ :				
Poor condition (grass cover < 50%).....	68	79	86	89
Fair condition (grass cover 50% to 75%).....	49	69	79	84
Good condition (grass cover > 75%).....	39	61	74	80
Impervious areas:				
Paved parking lots, roofs, driveways, etc. (excluding right-of-way)	98	98	98	98
Streets and roads:				
Paved; curbs and storm sewers (excluding right-of-way).....	98	98	98	98
Paved; open ditches (including right-of-way).....	83	89	92	93
Gravel (including right of way).....	76	85	89	91
Dirt (including right-of-way).....	72	82	87	89
Western desert urban areas:				
Natural desert landscaping (pervious areas only) ⁴	63	77	85	88
Artificial desert landscaping (impervious weed barrier, desert shrub with 1- to 2-inch sand or gravel mulch and basin borders).....	96	96	96	96
Urban districts:				
Commercial and business.....	85	89	92	94
Industrial.....	72	81	88	91
Residential districts by average lot size:				
1/8 acre or less (town houses).....	65	77	85	90
1/4 acre.....	38	61	75	83
1/3 acre.....	30	57	72	81
1/2 acre.....	25	54	70	80
1 acre.....	20	51	68	79
2 acres.....	12	46	65	82
<i>Developing urban areas</i>				
Newly graded areas (pervious areas only, no vegetation) ⁵	77	86	91	94
Idle lands (CN's are determined using cover types similar to those in table 2-2c).				

¹Average runoff condition, and $I_a = 0.2S$.

²The average percent impervious area shown was used to develop the composite CN's. Other assumptions are as follows: impervious areas are directly connected to the drainage system, impervious areas have a CN of 98, and pervious areas are considered equivalent to open space in good hydrologic condition. CN's for other combinations of conditions may be computed using figure 2-3 or 2-4.

³CN's shown are equivalent to those of pasture. Composite CN's may be computed for other combinations of open space cover type.

⁴Composite CN's for natural desert landscaping should be computed using figures 2-3 or 2-4 based on the impervious area percentage (CN = 98) and the pervious area CN. The pervious area CN's are assumed equivalent to desert shrub in poor hydrologic condition.

⁵Composite CN's to use for the design of temporary measures during grading and construction should be computed using figures 2-3 or 2-4, based on the degree of development (impervious area percentage) and the CN's for the newly graded pervious areas.

El Dorado County Design Rainfall
Precipitation Intensity (inches per hour) Duration Frequency
Return Period 10 Years

Mean Annual Precipitation	5 Min	10 Min	15 Min	30 Min	1 Hr	2 Hr	3 Hr	6 Hr	12 Hr	1 Day
8	0.76	0.53	0.43	0.31	0.22	0.15	0.12	0.09	0.06	0.04
10	0.95	0.67	0.54	0.38	0.27	0.19	0.15	0.11	0.08	0.05
12	1.133	0.80	0.65	0.46	0.32	0.23	0.19	0.13	0.09	0.06
14	1.32	0.93	0.76	0.53	0.38	0.27	0.22	0.15	0.11	0.08
16	1.51	1.06	0.87	0.61	0.43	0.30	0.25	0.17	0.12	0.09
18	1.70	1.20	0.98	0.69	0.48	0.34	0.28	0.20	0.14	0.10
20	1.89	1.33	1.08	0.76	0.54	0.38	0.31	0.22	0.15	0.11
22	2.08	1.46	1.19	0.84	0.59	0.42	0.34	0.24	0.17	0.12
24	2.27	1.60	1.30	0.92	0.65	0.45	0.37	0.26	0.18	0.13
26	2.46	1.73	1.41	0.99	0.70	0.49	0.40	0.28	0.20	0.14
28	2.65	1.86	1.52	1.07	0.75	0.53	0.43	0.30	0.21	0.15
30	2.84	2.0	1.63	1.15	0.81	0.57	0.46	0.33	0.23	0.16
35	3.31	2.33	1.90	1.34	0.94	0.66	0.54	0.38	0.27	0.19
40	3.78	2.66	2.17	1.53	1.08	0.76	0.62	0.43	0.31	0.22
45	4.25	3.00	2.44	1.72	1.21	0.85	0.69	0.49	0.34	0.24
50	4.73	3.33	2.71	1.91	1.34	0.95	0.77	0.54	0.38	0.27
55	5.2	3.66	2.98	2.10	1.48	1.04	0.85	0.60	0.42	0.30
60	5.67	3.99	3.25	2.29	1.61	1.14	0.93	0.65	0.46	0.32
65	6.14	4.33	3.52	2.48	1.75	1.23	1.00	0.71	0.50	0.35
70	6.62	4.66	3.80	2.67	1.88	1.33	1.08	0.76	0.54	0.38

Source: Design Rainfall Tables for El Dorado County prepared by Jim Goodridge, August 30, 2008

El Dorado County Design Rainfall
Precipitation Intensity (inches per hour) Duration Frequency
Return Period 100 Years

Mean Annual Precipitation	5 Min	10 Min	15 Min	30 Min	1 Hr	2 Hr	3 Hr	6 Hr	12 Hr	1 Day
8	1.07	0.75	0.61	0.43	0.3	0.21	0.17	0.12	0.09	0.06
10	1.34	0.94	0.77	0.54	0.38	0.27	0.22	0.15	0.11	0.08
12	1.60	1.13	0.92	0.65	0.46	0.32	0.26	0.18	0.13	0.09
14	1.87	1.32	1.07	0.76	0.53	0.37	0.31	0.21	0.15	0.11
16	2.14	1.51	1.23	0.86	0.61	0.43	0.35	0.50	0.17	0.12
18	2.41	1.69	1.38	0.97	0.68	0.48	0.39	0.28	0.19	0.14
20	2.67	1.88	1.53	1.08	0.76	0.54	0.44	0.31	0.22	0.15
22	2.94	2.07	1.69	1.19	0.84	0.59	0.48	0.34	0.24	0.17
24	3.21	2.26	1.84	1.30	0.91	0.64	0.52	0.37	0.26	0.18
26	3.47	2.45	1.99	1.40	0.99	0.70	0.57	0.40	0.28	0.20
28	3.74	2.63	2.15	1.51	1.06	0.75	0.61	0.43	0.30	0.21
30	4.01	2.82	2.30	1.62	1.14	0.80	0.65	0.46	0.32	0.23
35	4.68	3.29	2.68	1.89	1.33	0.94	0.76	0.54	0.38	0.27
40	5.34	3.76	3.07	2.16	1.52	1.07	0.87	0.61	0.43	0.30
45	6.01	4.23	3.45	2.43	1.71	1.20	0.98	0.69	0.49	0.34
50	6.68	4.70	3.83	2.70	1.9	1.34	1.09	0.77	0.54	0.38
55	7.35	5.17	4.22	2.97	2.09	1.47	1.20	0.84	0.59	0.42
60	8.02	5.65	4.60	3.24	2.28	1.61	1.31	0.92	0.65	0.46
65	8.69	6.12	4.98	3.51	2.47	1.74	1.42	1.00	0.70	0.49
70	9.35	6.59	5.36	3.78	2.66	1.87	1.53	1.07	0.76	0.53

Source: Design Rainfall Tables for El Dorado County prepared by Jim Goodridge, August 30, 2008

El Dorado County Design Rainfall
Precipitation Depth (inches) Duration Frequency
Return Period 2 Years

Mean Annual Precipitation	5 Min	10 Min	15 Min	30 Min	1 Hr	2 Hr	3 Hr	6 Hr	12 Hr	1 Day
8	0.04	0.06	0.07	0.10	0.14	0.19	0.23	0.33	0.46	0.65
10	0.05	0.07	0.09	0.12	0.17	0.24	0.29	0.41	0.58	0.81
12	0.06	0.08	0.10	0.14	0.20	0.29	0.35	0.49	0.69	0.98
14	0.07	0.10	0.12	0.17	0.24	0.33	0.41	0.57	0.81	1.14
16	0.08	0.11	0.14	0.19	0.27	0.38	0.47	0.66	0.93	1.30
18	0.09	0.13	0.15	0.22	0.31	0.43	0.52	0.74	1.04	1.47
20	0.10	0.14	0.17	0.24	0.34	0.48	0.58	0.82	1.16	1.63
22	0.11	0.15	0.19	0.26	0.37	0.53	0.64	0.90	1.27	1.79
24	0.12	0.17	0.21	0.29	0.41	0.57	0.70	0.99	1.39	1.95
26	0.13	0.18	0.22	0.31	0.44	0.62	0.76	1.07	1.50	2.12
28	0.14	0.2	0.24	0.34	0.47	0.67	0.82	1.15	1.62	2.28
30	0.15	0.21	0.26	0.36	0.51	0.72	0.87	1.23	1.74	2.44
35	0.17	0.24	0.30	0.42	0.59	0.84	1.02	1.44	2.02	2.85
40	0.20	0.28	0.34	0.48	0.68	0.95	1.17	1.64	2.31	3.26
45	0.22	0.31	0.38	0.54	0.76	1.07	1.31	1.85	2.60	3.67
50	0.25	0.35	0.43	0.60	0.85	1.19	1.46	2.05	2.89	4.07
55	0.27	0.38	0.47	0.66	0.93	1.31	1.60	2.26	3.18	4.48
60	0.30	0.42	0.51	0.72	1.02	1.43	1.75	2.46	3.47	4.89
65	0.32	0.45	0.56	0.78	1.10	1.55	1.90	2.67	3.76	5.29
70	0.35	0.49	0.6	0.84	1.19	1.67	2.04	2.87	4.05	5.70

Source: Design Rainfall Tables for El Dorado County prepared by Jim Goodridge, August 30, 2008

El Dorado County Design Rainfall
Precipitation Depth (inches) Duration Frequency
Return Period 10 Years

Mean Annual Precipitation	5 Min	10 Min	15 Min	30 Min	1 Hr	2 Hr	3 Hr	6 Hr	12 Hr	1 Day
8	0.06	0.09	0.11	0.15	0.22	0.30	0.37	0.52	0.73	1.03
10	0.08	0.11	0.14	0.19	0.27	0.38	0.46	0.65	0.92	1.29
12	0.09	0.13	0.16	0.23	0.32	0.45	0.56	0.78	1.10	1.55
14	0.11	0.16	0.19	0.27	0.38	0.53	0.65	0.91	1.28	1.81
16	0.13	0.18	0.22	0.31	0.43	0.61	0.74	1.04	1.47	2.07
18	0.14	0.20	0.24	0.34	0.48	0.68	0.83	1.17	1.65	2.33
20	0.16	0.22	0.27	0.38	0.54	0.76	0.93	1.30	1.83	2.58
22	0.17	0.24	0.30	0.42	0.59	0.83	1.02	1.43	2.02	2.84
24	0.19	0.27	0.33	0.46	0.65	0.91	1.11	1.56	2.20	3.10
26	0.20	0.29	0.35	0.50	0.70	0.98	1.20	1.69	2.39	3.36
28	0.22	0.31	0.38	0.53	0.75	1.06	1.30	1.82	2.57	3.62
30	0.24	0.33	0.41	0.57	0.81	1.14	1.39	1.95	2.75	3.88
35	0.28	0.39	0.47	0.67	0.94	1.33	1.62	2.28	3.21	4.52
40	0.32	0.44	0.54	0.76	1.08	1.51	1.85	2.61	3.67	5.17
45	0.35	0.50	0.61	0.86	1.21	1.70	2.08	2.93	4.13	5.81
50	0.39	0.55	0.68	0.95	1.34	1.89	2.31	3.26	4.59	6.46
55	0.43	0.61	0.75	1.05	1.48	2.08	2.54	3.58	5.05	7.11
60	0.47	0.67	0.81	1.15	1.61	2.27	2.78	3.91	5.50	7.75
65	0.51	0.72	0.88	1.24	1.75	2.46	3.01	4.23	5.96	8.40
70	0.55	0.78	0.95	1.34	1.88	2.65	3.24	4.56	6.42	9.04

Source: Design Rainfall Tables for El Dorado County prepared by Jim Goodridge, August 30, 2008

El Dorado County Design Rainfall
Precipitation Depth (inches) Duration Frequency
Return Period 100 Years

Mean Annual Precipitation	5 Min	10 Min	15 Min	30 Min	1 Hr	2 Hr	3 Hr	6 Hr	12 Hr	1 Day
8	0.09	0.13	0.15	0.22	0.30	0.43	0.52	0.74	1.04	1.46
10	0.11	0.16	0.19	0.27	0.38	0.54	0.65	0.92	1.30	1.83
12	0.13	0.19	0.23	0.32	0.46	0.64	0.78	1.11	1.56	2.19
14	0.16	0.22	0.27	0.38	0.53	0.75	0.92	1.29	1.82	2.56
16	0.18	0.25	0.31	0.43	0.61	0.86	1.05	1.47	2.08	2.92
18	0.20	0.28	0.34	0.49	0.68	0.96	1.18	1.66	2.33	3.29
20	0.22	0.31	0.38	0.54	0.76	1.07	1.31	1.84	2.59	3.65
22	2.24	0.34	0.42	0.59	0.84	1.18	1.44	2.03	2.85	4.02
24	0.27	0.38	0.46	0.65	0.91	1.28	1.57	2.21	3.11	4.38
26	0.29	0.41	0.50	0.70	0.99	1.39	1.70	2.39	3.37	4.75
28	0.31	0.44	0.54	0.76	1.06	1.50	1.83	2.58	3.63	5.11
30	0.33	0.47	0.57	0.81	1.14	1.61	1.96	2.76	3.89	5.48
35	0.39	0.55	0.67	0.94	1.33	1.87	2.29	3.22	4.54	6.39
40	0.45	0.63	0.77	1.08	1.52	2.14	2.62	3.68	5.19	7.31
45	0.50	0.71	0.86	1.21	1.71	2.41	2.94	4.14	5.84	8.22
50	0.56	0.78	0.96	1.35	1.90	2.68	3.27	4.60	6.48	9.13
55	0.61	0.86	1.05	1.48	2.09	2.94	3.60	5.06	7.13	10.05
60	0.67	0.94	1.15	1.62	2.28	3.21	3.92	5.53	7.78	10.96
65	0.72	1.02	1.25	1.75	2.47	3.48	4.25	5.99	8.43	11.87
70	0.78	1.10	1.34	1.89	2.66	3.75	4.58	6.45	9.08	12.78

Source: Design Rainfall Tables for El Dorado County prepared by Jim Goodridge, August 30, 2008

FIG. 2.5.1 Runoff Coefficients for 10-yr Event below 1,640'

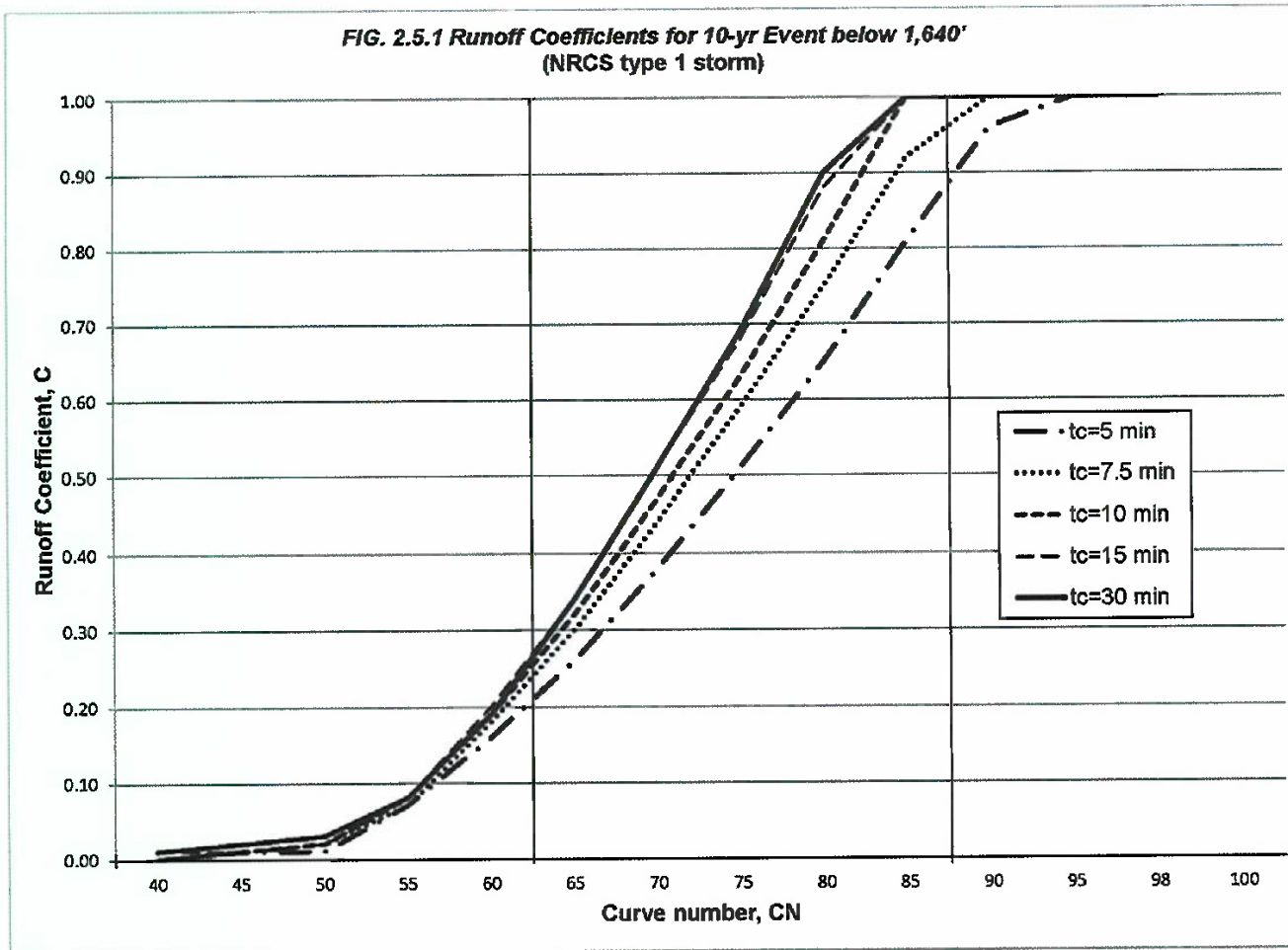

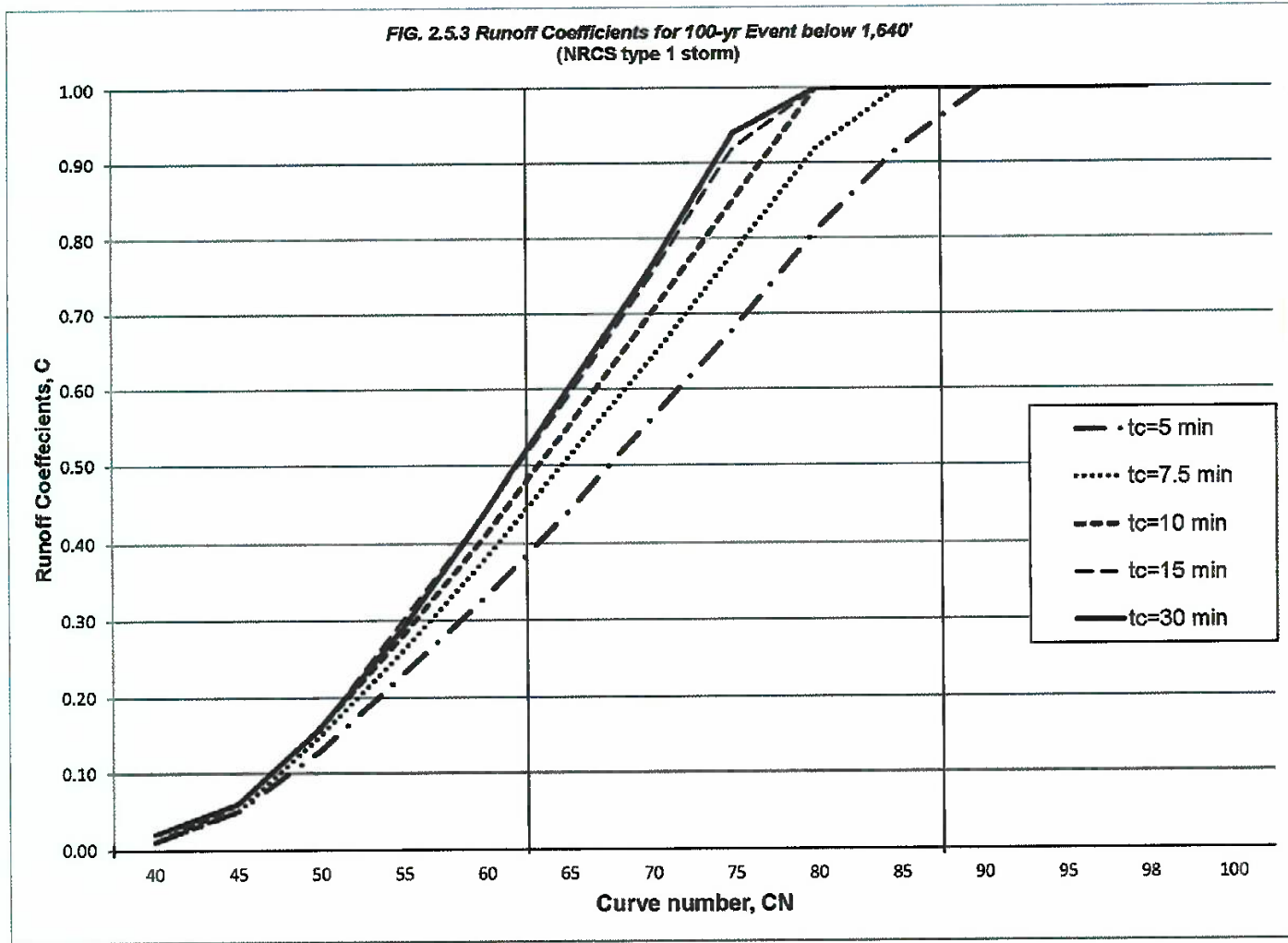

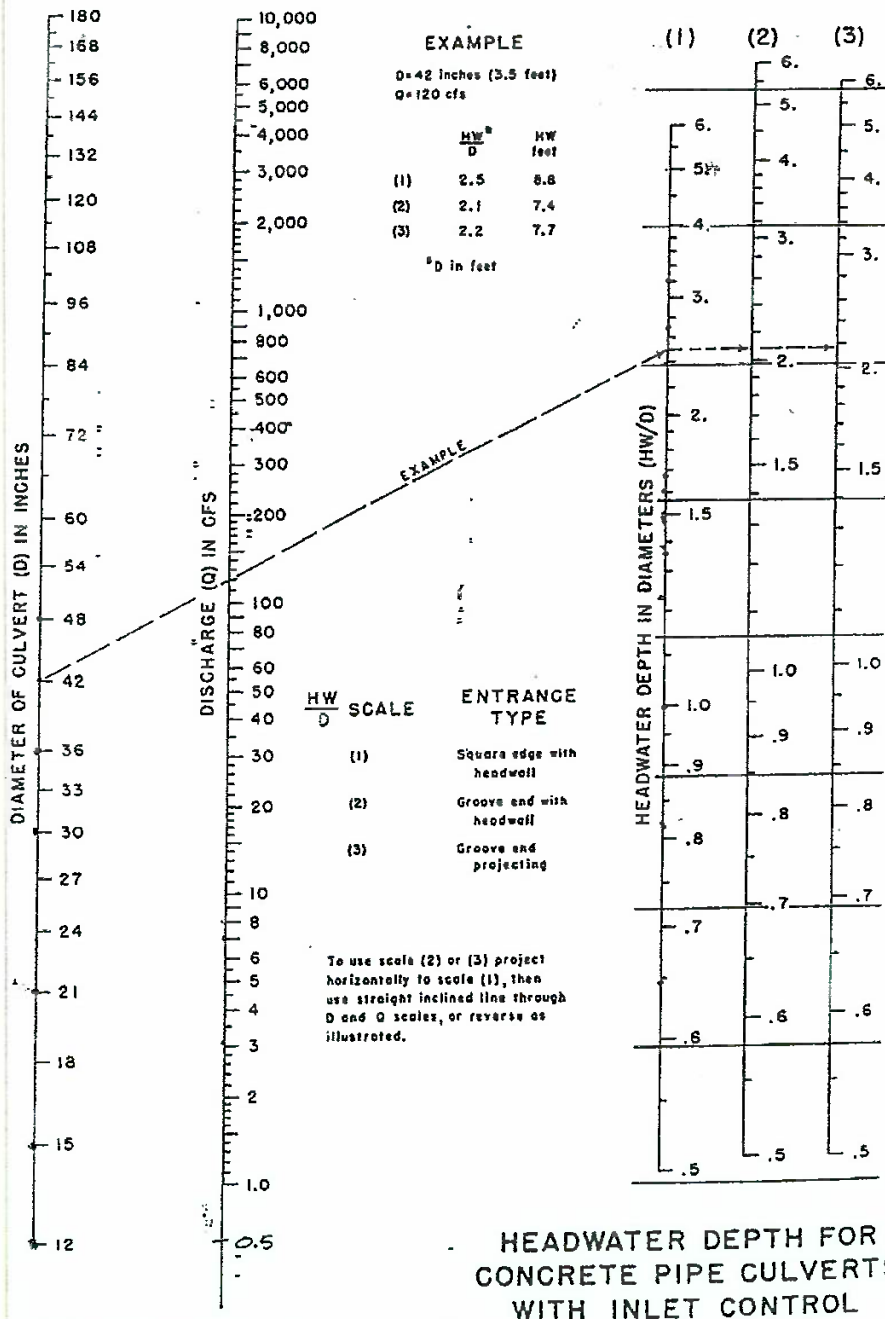

BUREAU OF PUBLIC ROADS JAN. 1963

CAMERON PARK
DRAINAGE STUDY

PREPARED FOR:

EL DORADO COUNTY
DEPARTMENT OF TRANSPORTATION

JUNE, 1995

RECEIVED
APR 11 1997
GENE E. THORNE
& ASSOCIATES, INC.

PREPARED BY:

PSOMAS AND ASSOCIATES

2485 NATOMAS PARK DRIVE
SUITE 250
SACRAMENTO, CA 95833

**TABLE 1-1
BASIN AREAS**

Sub Basin No.	Sub Basin Area (square miles)	Sub Basin No.	Sub Basin Area (square miles)	Sub Basin No.	Sub Basin Area (square miles)
CA1	0.31	CA11	0.32	CA23	0.32
CA2	0.51	CA12	0.7	CA24	5.58
CA3	0.81	CA13	1.03	CA25	5.64
CA4	1.01	CA14	0.31	CA26	0.32
CA5	1.07	CA15	1.66	CA27	0.37
CA6	1.23	CA16	3.33	CA28	0.83
CA7	0.32	CA17	3.78	CA29	0.92
CA8	0.38	CA18	3.89	CA30	1.16
CA9	0.63	CA19	0.47	CA31	0.69
CA10	0.21	CA20	0.24	CA32	0.92
CA11	0.32	CA21	0.97	CA33	0.99

Do not include map.

- Sterling Way Reach - Adjacent to Sterling Way upstream from Cameron Lake
- Mira Loma Reach - Runs east to west from Cameron Road, across the Cameron Park Airport to Deer Creek just downstream from Cameron Lake
- Deer Creek North - The Deer Creek main channel extending from Cameron Lake downstream to the Cameron Park Golf Course
- Deer Creek South - The Deer Creek main channel extending from the golf course (golf course not included) to the end of the study area just south of Highway 50
- Chelsea Reach - Adjacent to Chelsea Road, beginning at Bass Lake and extending downstream to the confluence of Deer Creek just south of Highway 50

These six channel reaches are the major conveyance systems in the study area. Facilities along these reaches are the subject of this study. The crossings are identified in Table 1-2.

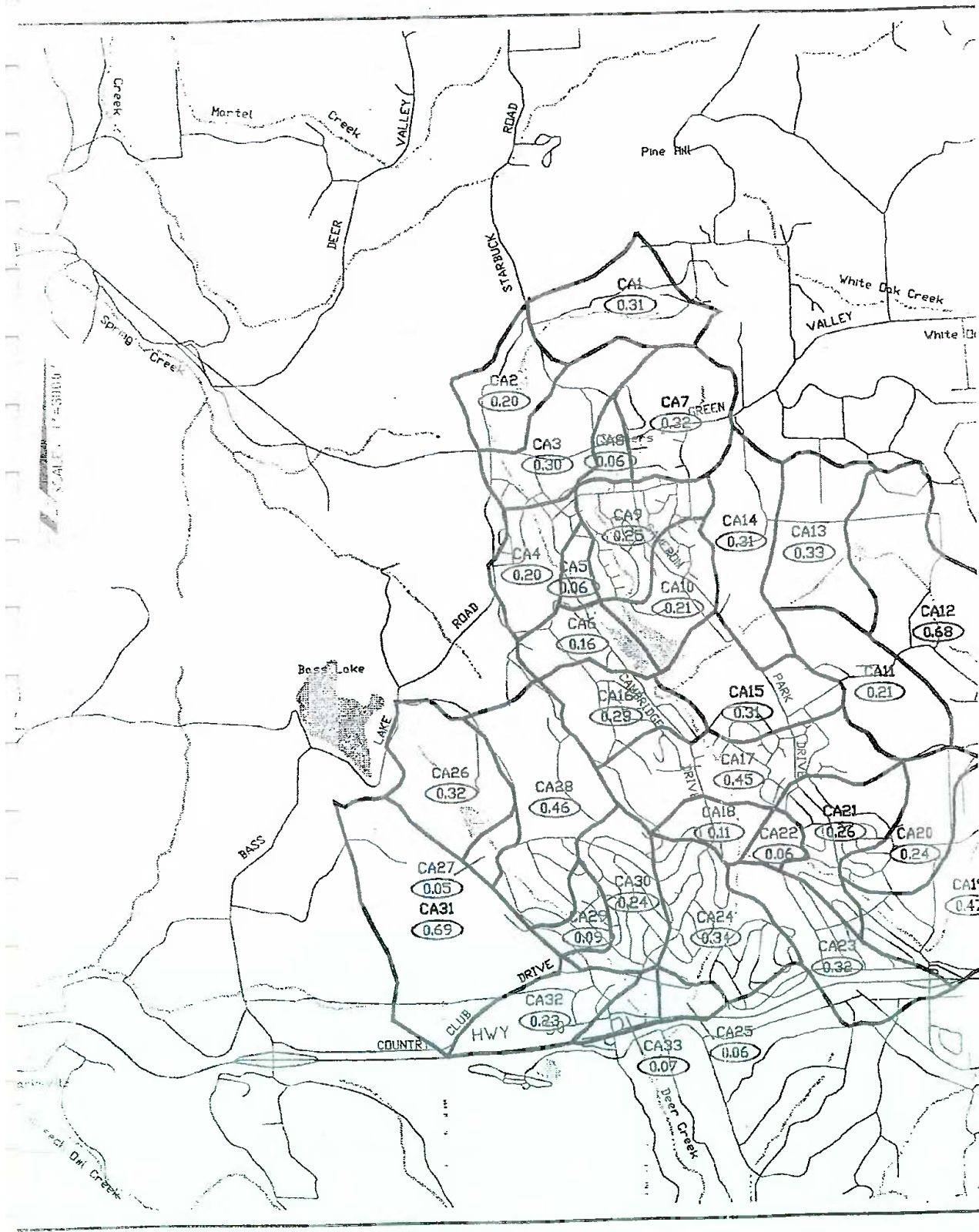

**TABLE 1-2
STEAM CROSSING LOCATIONS**

Reach	Cross Section and Street Crossing	Size and Type of Culvert
Mira Loma	ML6 - Boeing Road ML9 - Cameron Park Airport Runway ML14 - Cameron Park Drive	7' x 10' CMPA 6' x 10' CMPA 7' x 12' CMPA
Royal Park	RP13 - Royal Park Drive RP21 - Canada Drive RP26 - Cimmaron Road RP31 - Cameron Park Drive	Double 60" CMP 78" CMP 5' x 7' CMPA 4' x 8' CMPA
Sterling Way	SW3 - Recreation Park SW7 - Royal Park Drive SW12 - Cambridge Road → SW19 - Gateway Drive SW26 - Green Valley Road	4' x 6' CMPA 90" CMP Triple 54" CMP 7' x 11' CMPA 84" CMP
Deer Creek South	DS6 - Cameron Road DS10 - Highway 50 DS14 - Country Club Drive	Double 8' x 8' RCB 12' x 16' RCA Double 6.5' x 24' RCB
Deer Creek North	DN4 - Oxford Drive	Triple 8' x 8' RCB
Chelsea	CH3 - Cameron Road CH5 - Highway 50 CH11 - Cambridge Road CH16 - Country Club Drive CH21 - Kimberley Road CH28 - Wentworth Road CH40 - Knollwood Drive	96" CMP 6' x 6' RCB Triple 60" CMP 4.24' x 6' RCB Double 60" CMP Double 60" CMP Triple 3' x 5' CMPA

Drainage sheds tributary to all reaches are at least partially developed with the upper shed of the Mira Loma reach containing the least development and all other reaches with over 50% developed sheds. Surface conditions will be discussed in further detail in Chapter 2, Hydrologic Characteristics.

GENERAL APPROACH

In this study, three major steps were necessary to achieve our goal of identifying necessary drainage improvements for Cameron Park. The first step was to identify the existing conditions with regard to hydrologic parameters and hydraulic facilities. Once the existing conditions were established, the second step of hydrologic and hydraulic modeling of these conditions was performed and calibrated to the extent possible. With the existing condition models in place, a third step to identify alternative, proposed improvements was carried out.

CHAPTER 2 HYDROLOGIC CHARACTERISTICS

RAINFALL

Rainfall data for the Cameron Park area has been developed from tables provided in the Draft El Dorado County Drainage Manual⁽⁶⁾ and is based on a statistical analysis of local rain gauges. Table 2-1 shows the rainfall data used in this study. The design storm used in the hydrologic modeling is a balanced, 24 hour storm. The 100 year return frequency storm is used for sizing channel facilities and mapping of flood plains. The 10 year rainfall is also modeled to provide the resulting channel profiles under the 10 year storm conditions.

TABLE 2-1
CAMERON PARK RAINFALL (INCHES)

	5 min	15 min	1 hr	2 hrs	3 hrs	6 hrs	12 hrs	24 hrs
100 year	0.41	0.72	1.41	2.01	2.45	3.33	5.11	7.12
10 year	0.25	0.45	0.92	1.32	1.61	2.28	3.43	4.77

SOILS

An important characteristic of the watershed in storm runoff modeling is the hydrologic soil classifications. The Soil Conservation Service has classified soils in four major categories from A, most pervious, to D, least pervious soils.

Figure 2-1, Soil Types, shows the various hydrologic soils types found in the Cameron Park study area. Tables 2-2 and 2-3 show hydrologic data for the Cameron Park watershed which includes the percentage of each soil type in each sub-basin, which is essential in the determination of runoff.

LAND USE

Existing land uses in Cameron Park consist mainly of single family residential with the following exceptions: (1) highway commercial adjacent to Highway 50; (2) Cameron Park Golf Course; (3) Cameron Park Airport; and (4) scattered undeveloped areas of open space. Table 2-2 shows the sub-basin development amounts (in terms of total area) under current conditions.

Build-out of the current General Plan land use was used to determine future runoff. Table 2-3 shows the sub-basin development amounts (in terms of total area) under future, build-out conditions. Figure 2-2, Cameron Park Study Land Use, shows the future land uses which the future conditions runoff models were based. The designated uses generally follow current development trends with a majority of single family residential uses throughout the study area with the exception of the highway commercial and other existing uses mentioned previously.

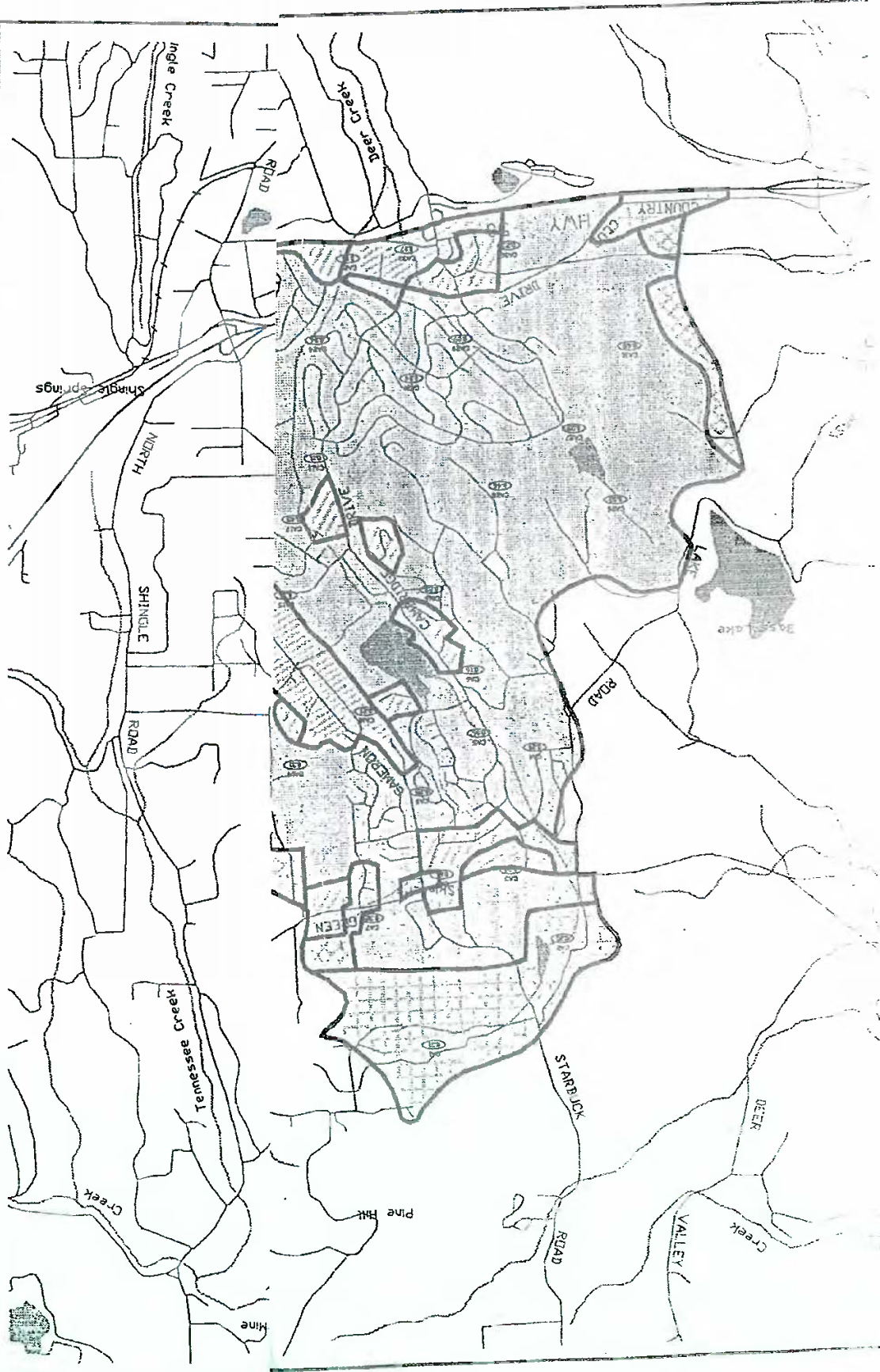

FIGURE 2-2
CAMERON
PARK
STUDY
LAND USE

PSOMAS

Psomas & Associates-Sacramento
2485 Natomas Park Dr., Ste. 250
Sacramento, California 95833
916/929-7100

Engineers
Surveyors
Planners

**TABLE 4-1 (continued)
CULVERT AND CHANNEL DEFICIENCIES**

Reach	Cross Section and Street Crossing	Size and Type of Culvert	Top of Road Elev.	Capacity of Culvert (1)	100 Year Flow (CFS)		W.S. Elevation (ft)		Comments
					Existing (2)	Future (3)	Existing (2)	Future (3)	
Royal Park	RP21 - Canada Drive	78" CMP	1321.8	320	226	317	1320.1	1321.5	Both existing and future are acceptable.
	RP26 - Cimmaron Road	5' x 7' CMPA	1332.0	290	226	325	1330.9	1332.6	Existing is acceptable. Future overtopping is marginal.
	RP31 - Cimmaron Road	4' x 8' CMPA	1351.3	265	196	287	1351.1	1352.0	Existing is acceptable. Future overtopping is marginal.
Sterling Way	SW7 - Royal Park Drive	90" CMP	1267.5	265	483	661	1270.4	1270.4	Severe overtopping under both existing and future conditions.
	SW12 - Cambridge Road	Triple 54" CMP's	1275.5	500	464	614	1275.4	1275.9	Existing is acceptable. Future overtopping is marginal.
	SW19 - Gateway Drive	7' x 11' CMPA	1309.0	700	346	460	1302.5	1303.4	Both existing and future are acceptable.
	SW26 - Green Valley Road	84" CMP	1322.0	360	210	275	1319.0	1320.1	Both existing and future are acceptable.
Deer Creek South	DS6 - Cameron Road	Double 8' by 8' RCB	1072.0	775	2680	3695	1076.2	1076.1	High tailwater problem. Severe flooding under existing and future conditions.
	DS10 - Highway 50	12' by 16' RCA	1092.0	2175	2680	3695	1093.1	1094.4	Culvert capacity problem. Severe flooding under existing and future conditions.
	DS14 - Country Club Drive	Double 6.5' by 24' RCB	1097.6	3590	2674	3775	1097.4	1098.9	Existing is acceptable. Future overtopping is severe.
Deer Creek North	DN4 - Oxford Drive	Triple 8' x 8' RCB	1218.4	2200	1464	2093	1215.8	1216.6	Existing is acceptable. Future overtopping is marginal.
Chelsea	CH3 - Cameron Road	96" CMP	1069.0	315	648	1017	1070.8	1070.3	High tailwater problem. Severe flooding under existing and future conditions.

- (1) Capacity based on zero freeboard and tailwater elevation of existing 100 year flows.
(2) Existing conditions based on no improvements.
(3) Future conditions based on future buildout, no improvements.

TABLE 4-1 continued next page

**TABLE 4-1 (continued)
CULVERT AND CHANNEL DEFICIENCIES**

Reach	Cross Section and Street Crossing	Size and Type of Culvert	Top of Road Elev.	Capacity of Culvert (1)	100-Year Flow (CFS)		W.S. Elevation (ft)		Comments
					Existing (2)	Future (3)	Existing (2)	Future (3)	
Chelsea	CH5 - Highway 50	6' x 6' RCB	1088.0	715	648	1017	1084.7	1089.7	Existing is acceptable. Future overtopping is severe.
	CH11 - Cambridge Road	Triple 60" CMP	1095.5	800	1035	1588	1094.2	1096.5	Culvert capacity problem. Severe flooding under future conditions.
	CH15 - Country Club Drive	4.25' x 6' RCB	1098.0	0	521	735	1100.2	1100.0	High tailwater problem. Severe flooding under existing and future conditions.
	CH21 - Kimberley Road	Double 60" CMP's	1108.0	330	395	614	1108.4	1109.2	High tailwater problem. Severe flooding under existing and future conditions.
	CH23 - Wentworth Road	Double 60" CMP's	1119.7	435	382	657	1118.1	1119.9	Existing is acceptable. Future overtopping is severe.
	CH40 - Knollwood Drive	Triple 9' x 5' CMPA	1165.0	290	232	391	1161.9	1162.4	Both existing and future are acceptable.

- (1) Capacity based on zero freeboard and tailwater elevation of existing 100 year flows.
- (2) Existing conditions based on no improvements.
- (3) Future conditions based on future buildout, no improvements.

Table 4-2, Recommended Improvements, shows the recommended replacement culverts and channel sections.

**TABLE 4-2
RECOMMENDED IMPROVEMENTS**

CROSS SECTION AND STREET CROSSING	SIZE AND TYPE OF EXISTING CULVERT	RECOMMENDED IMPROVEMENT	W.S. ELEVATIONS			
			100 YEAR EVENT			10 YEAR EVENT
			EXISTING COND. WITHOUT IMPROVEMENTS	FUTURE COND. WITHOUT IMPROVEMENTS	FUTURE COND. WITH IMPROVEMENTS	FUTURE COND. WITH IMPROVEMENTS
ML14 - Cameron Park Drive	7' x 12' CMPA	Replace with double 8' x 8' RCB's	1200.0	1261.0	1258.3	1252.8
RP13 - Royal Park Drive	Double 60" CMP	Replace with double 5' x 8' RCB's; lower channel w/s and d/s	1263.8	1263.8	1260.5	1259.1

TABLE 4-2 continued next page

OFF-SITE WATERSHED EXHIBIT MAP

GREENWOOD ESTATES

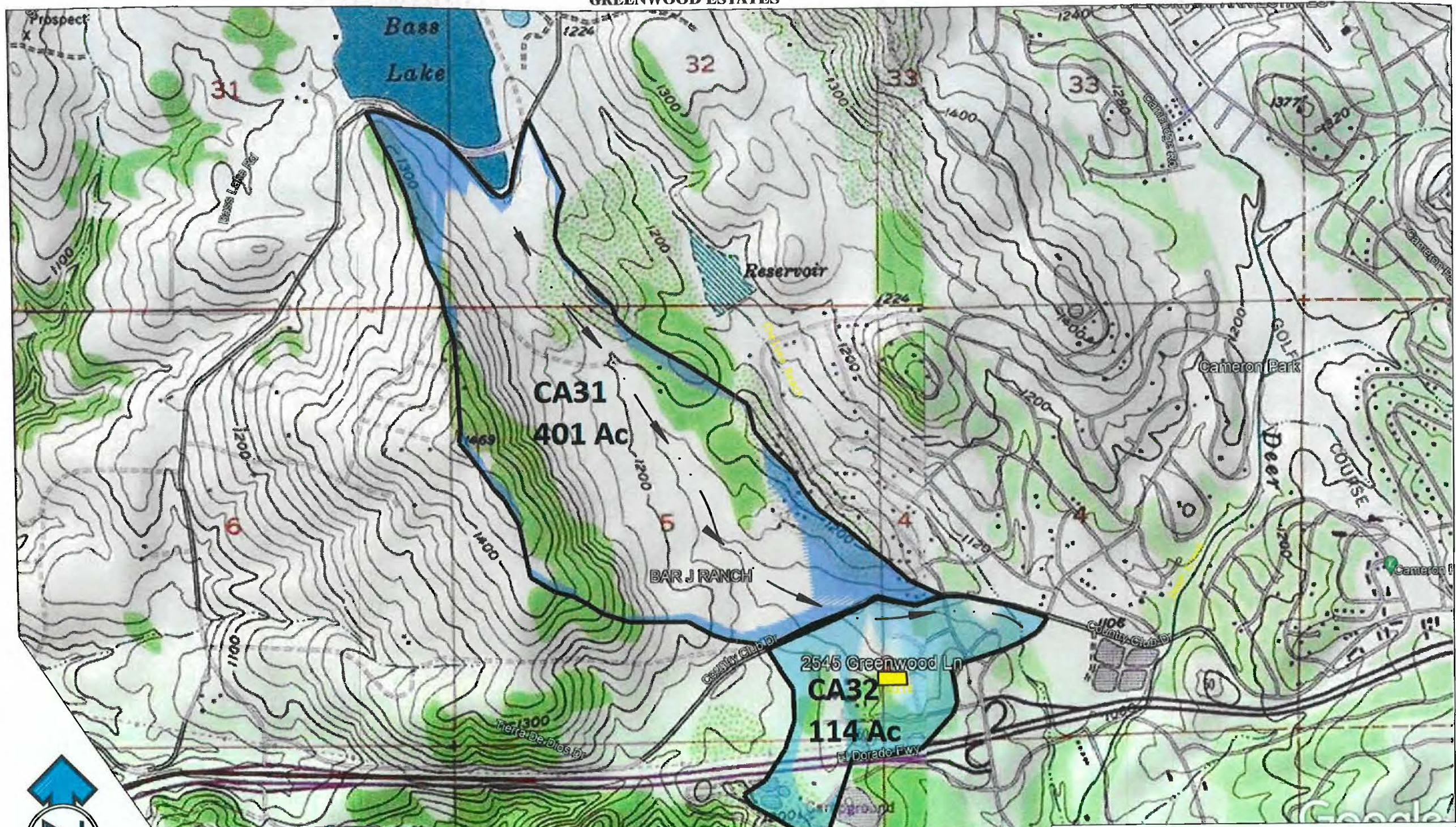

**LEBECK
ENGINEERING, INC.**
3430 ROBIN LANE, BLDG. #2
CAMERON PARK, CA 95682
Ph. (530) 677-4080

Prepared For: **JOE JAUDI**
2216 VIA SUBRIA
VISTA, CA 92084
760-664-7196
JOSJAUDI@AOL.COM

Project: 20-133
SEPT. 2021
ENG'R: B. Lebeck

Sheet No.
W1

WATERSHED AERIAL EXHIBIT MAP

GREENWOOD ESTATES

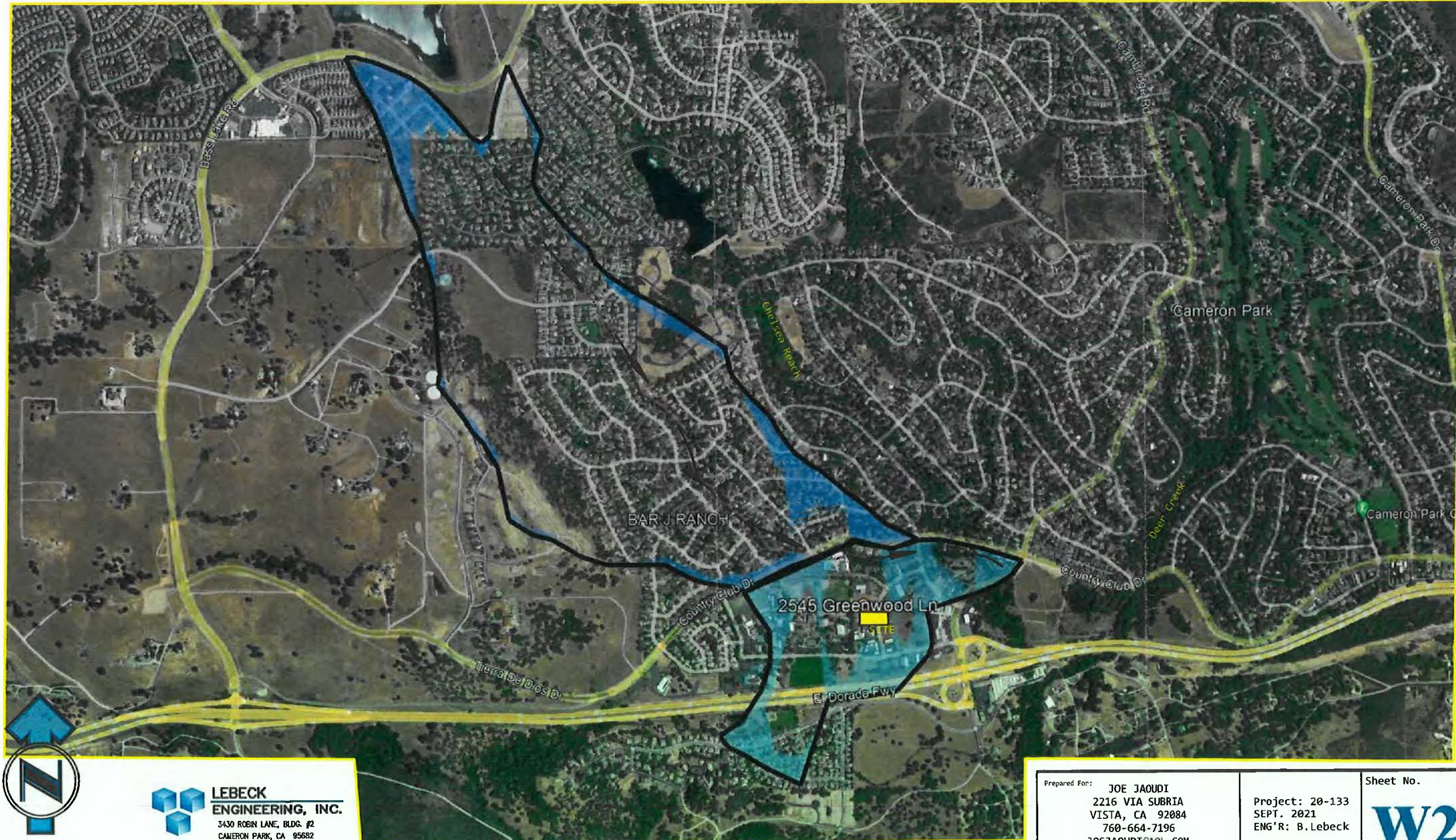

**LEBECK
ENGINEERING, INC.**
3430 ROBIN LANE, BLDG. #2
CAMERON PARK, CA 95682
Ph. (530) 677-4060

Prepared For: **JOE JAUDI**
2216 VIA SUBRIA
VISTA, CA 92084
760-664-7196
JOSJAUDI@AOL.COM

Project: 20-133
SEPT. 2021
ENG'R: B. Lebeck

Sheet No.
W2

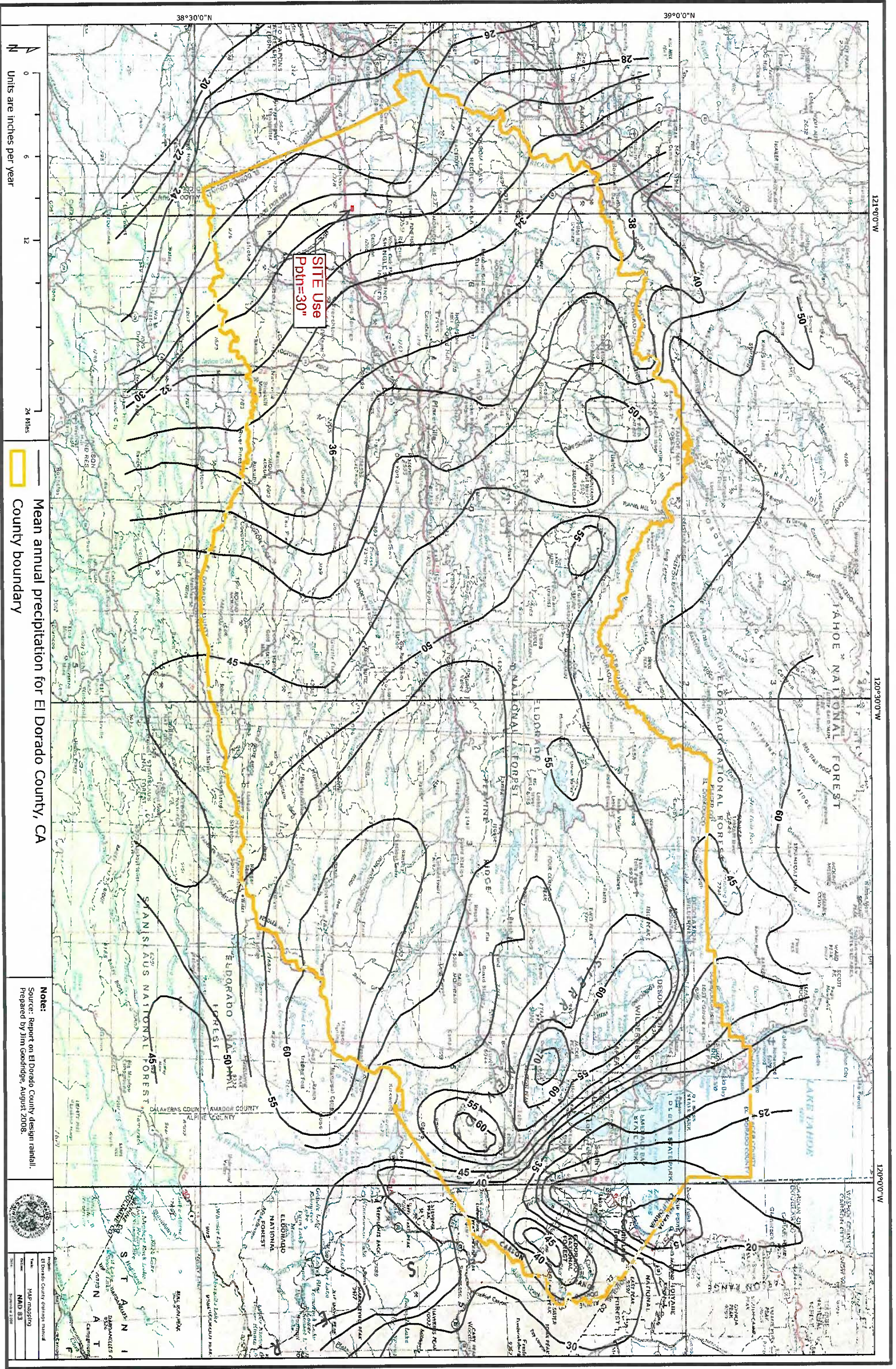

0 6 12 24 Miles

Mean annual precipitation for El Dorado County, CA

Note: Report on El Dorado County design rainfall. Prepared by Jim Goodridge, August 2008.

El Dorado County Geographic Information System
 MAP MAPPING
 MA0 83
 11/10/2008

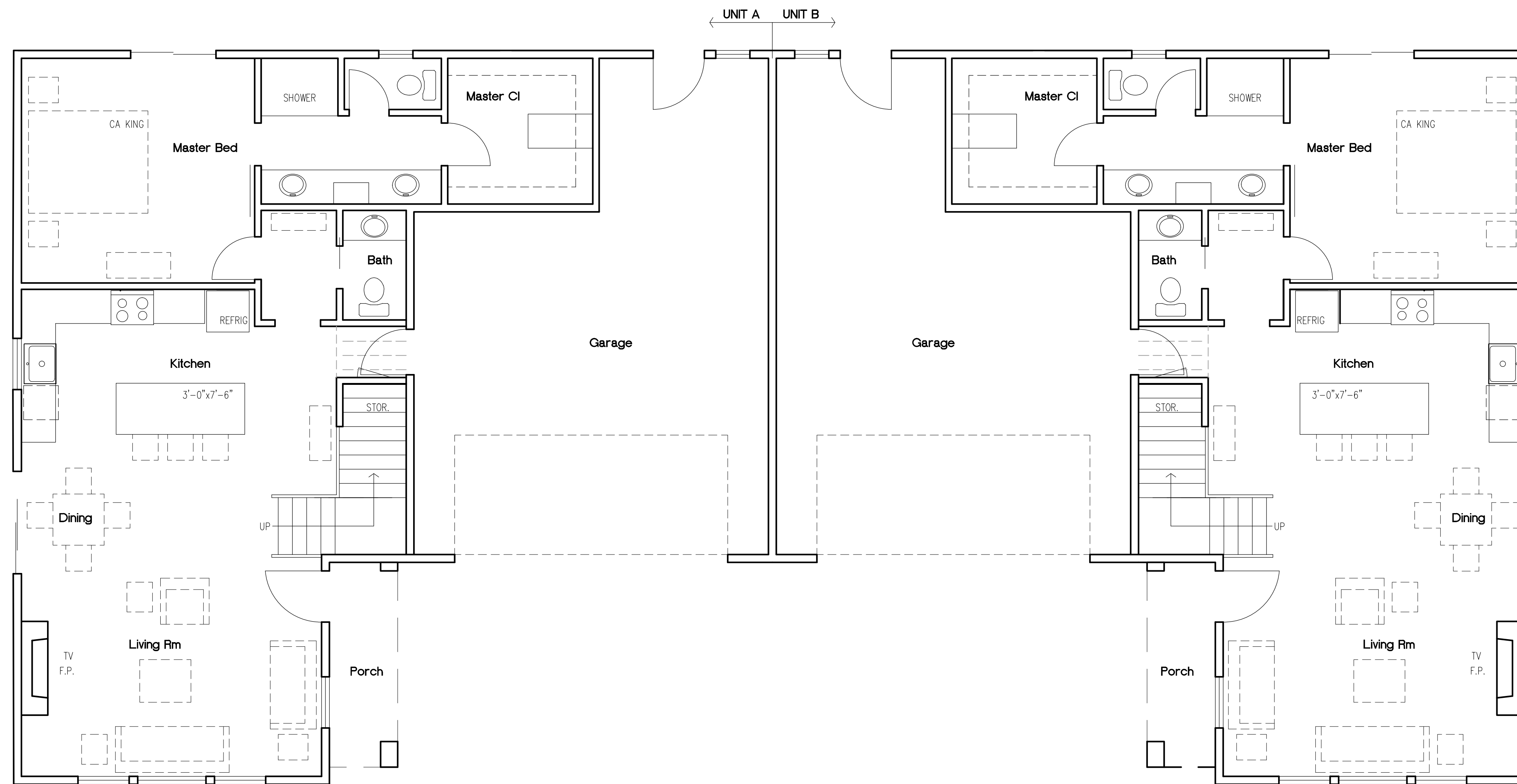

Ground Floor Plan

1047 s.f. Conditioned Space
 527 s.f. Garage
 48 s.f. Porch

Unit total

1047 s.f. Ground Floor
 872 s.f. 2nd Floor
 1,919 s.f. Total conditioned space

Bldg total - 2 Units

3838 s.f. Total conditioned space

5 Bldg total -10 Units

19,190 s.f. Total conditioned space

BRIAN WICKERT
 ARCHITECT
 P.O. BOX 2106
 SHINGLE SPRINGS CA 95682
 530-401-3390

GreenWood

Cameron Park

SCALE 1/4" = 1'-0"

DATE 10-1-21

DRAWING GROUND FLOOR PLANS

SHEET

NORTH

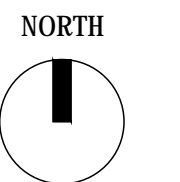

A2

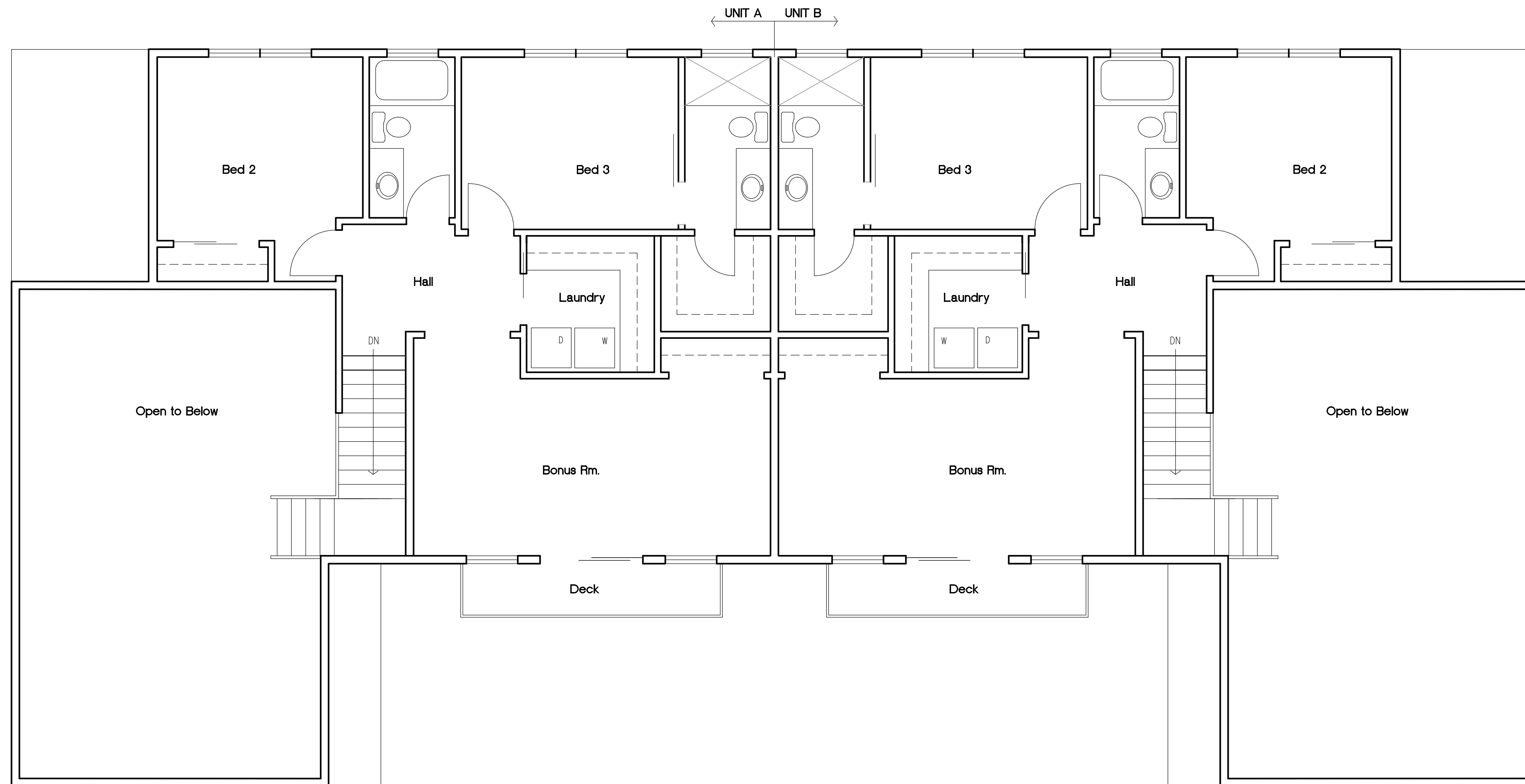

BRIAN WICKERT
 ARCHITECT
 P.O. BOX 2106
 SHINGLE SPRINGS CA 95682
 530-401-3390

GreenWood
 Cameron Park

SCALE 1/4" = 1'-0"
 DATE 10-1-21
 DRAWING SECOND FLOOR PLAN
 SHEET

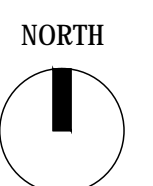

A3

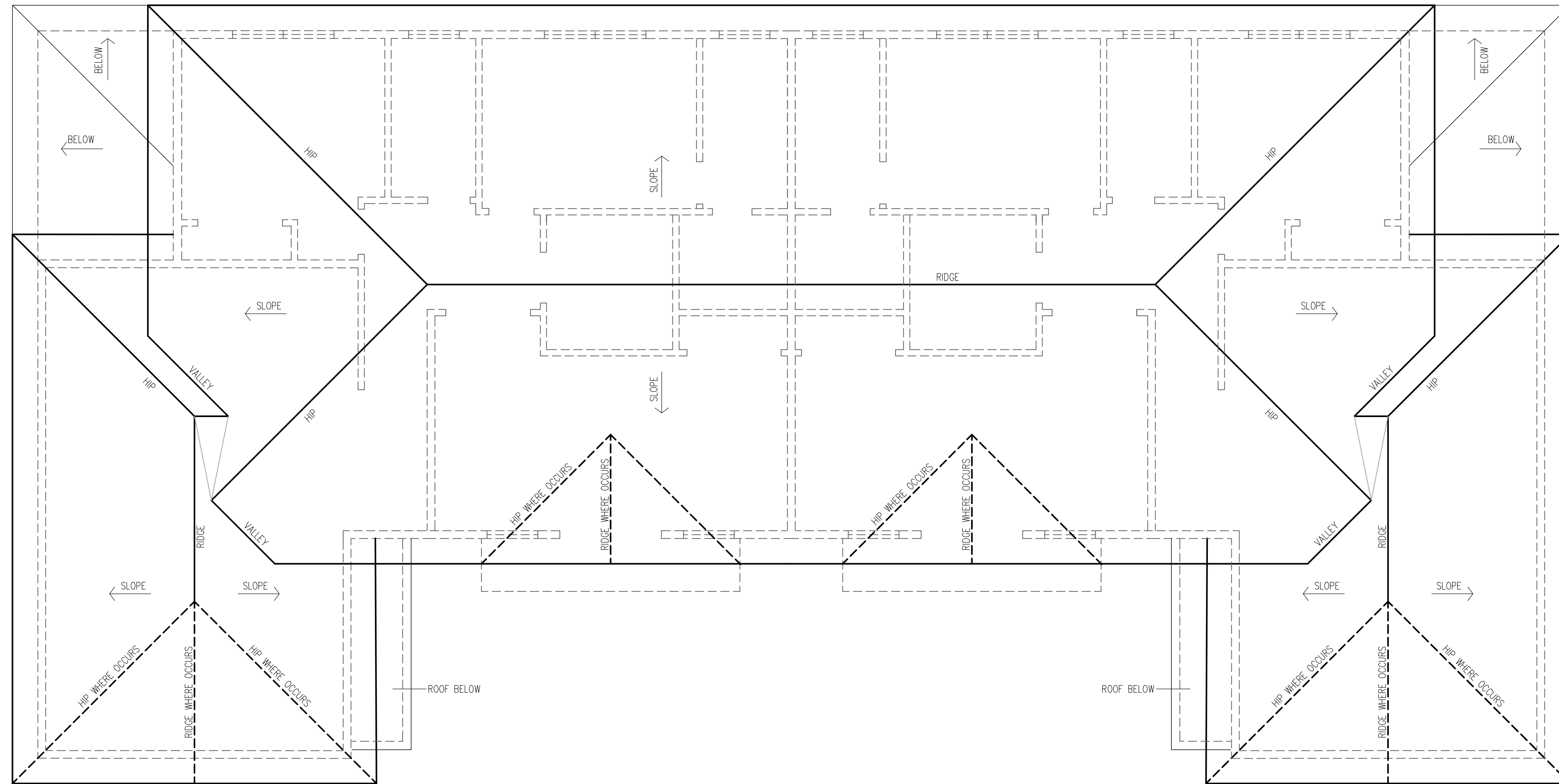

GreenWood
Cameron Park

BRIAN WICKERT
ARCHITECT
P.O. BOX 2106
SHINGLE SPRINGS CA 95682
530-401-3390

SCALE 1/4" = 1'-0"
DATE 10-1-21
DRAWING ROOF PLAN
SHEET

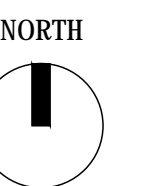

A4



ELEVATION OPT 2



ELEVATION OPT 1

GreenWood
Cameron Park

BRIAN WICKERT
ARCHITECT
P.O. BOX 2106
SHINGLE SPRINGS CA 95682
530-401-3390

SCALE 1/4" = 1'-0"
DATE 10-1-21
DRAWING FRONT ELEVATIONS
SHEET

A5

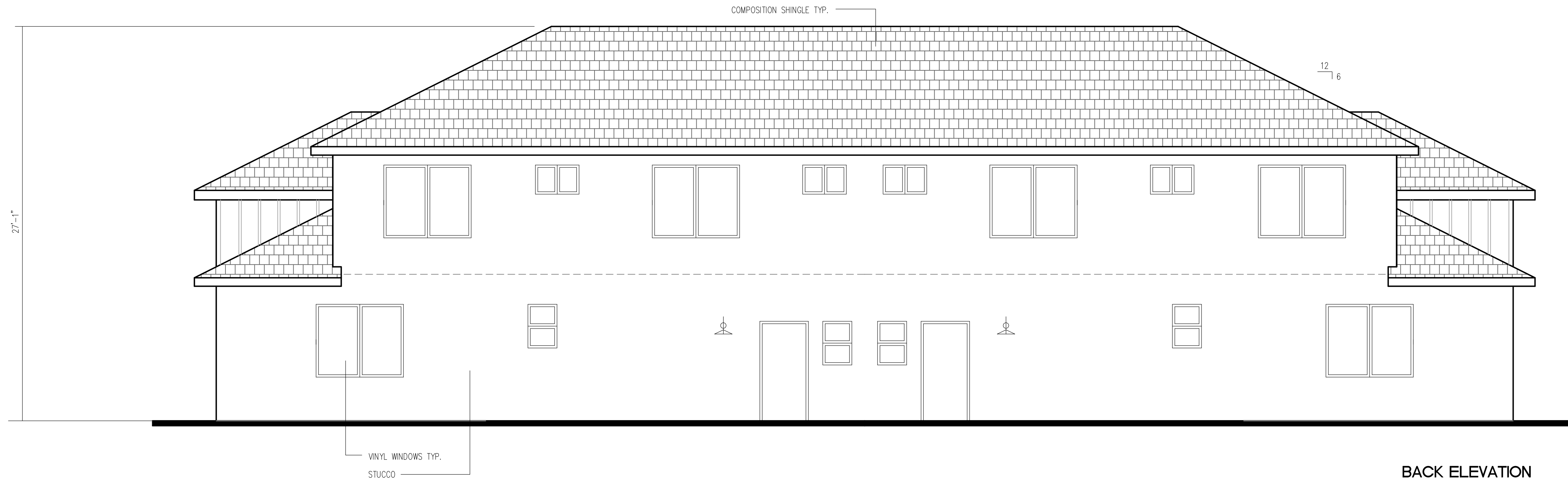

BACK ELEVATION

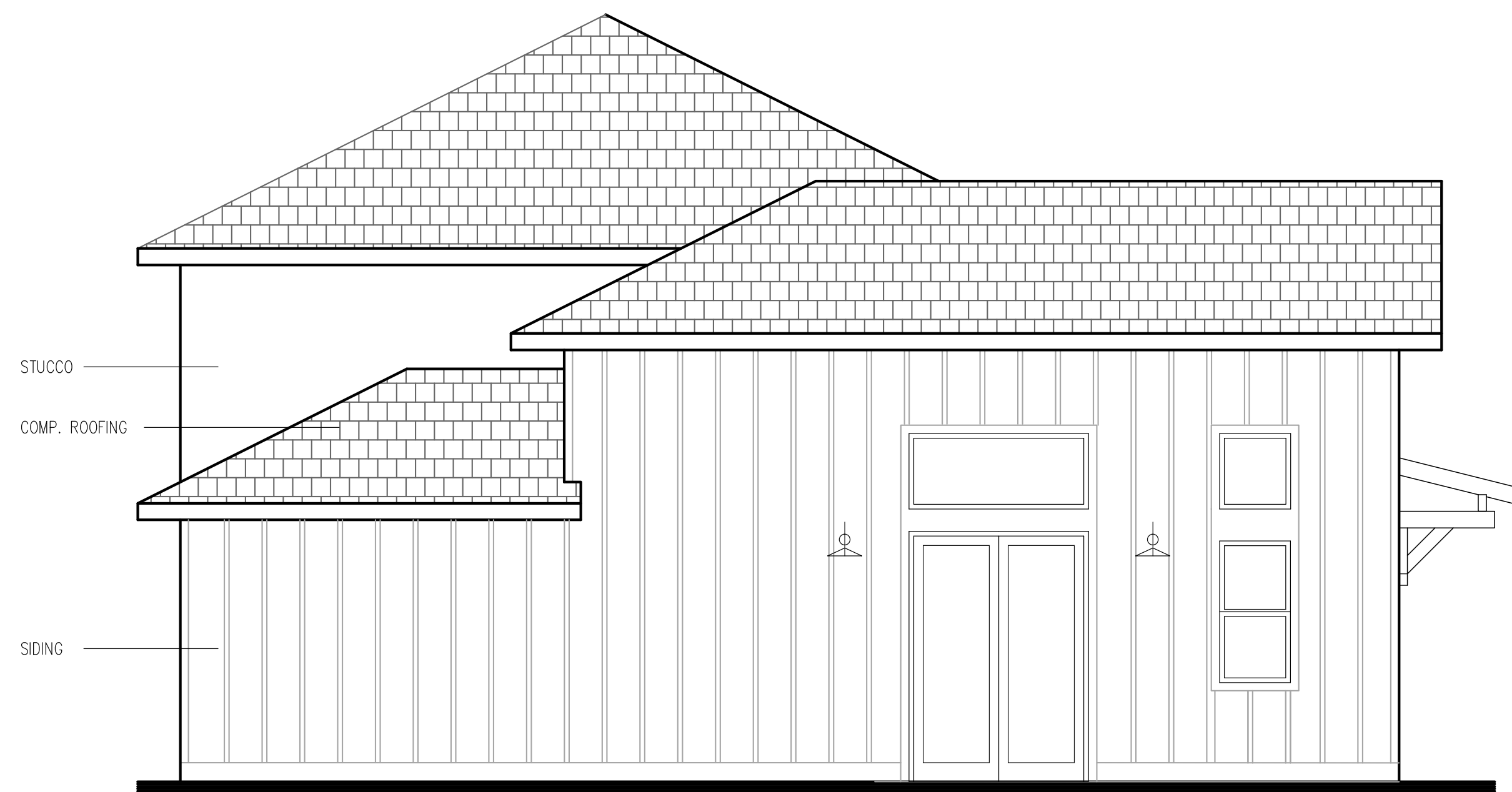

SIDE ELEVATION TYP.

BRIAN WICKERT
 ARCHITECT
 P.O. BOX 2106
 SHINGLE SPRINGS CA 95682
 530-401-3390

GreenWood
 Cameron Park

SCALE 1/4" = 1'-0"
 DATE 10-1-21
 DRAWING ELEVATIONS
 SHEET

A6

Greenwood Estates Preliminary Landscape Planting Plan

2545 Greenwood Lane, Cameron Park, CA 95682
Lot 46, Cameron Park North, Unit No. 5
APN: 082-411-004 - El Dorado County, CA
October 2021

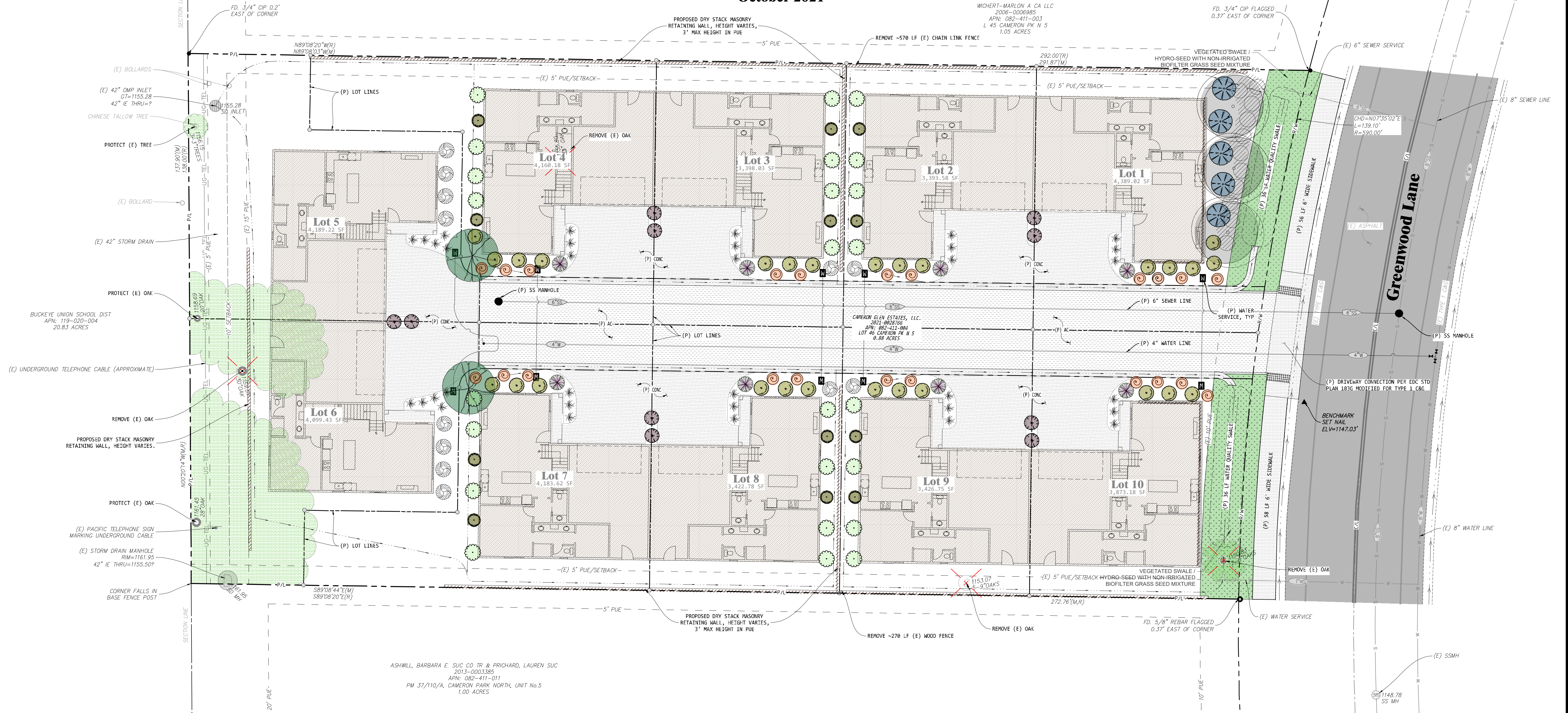

Planting Plan Notes	
1)	Recirculating water systems shall be used for water features.
2)	4,857 sq. ft. of landscape area.
3)	A minimum 3-inch layer of organic mulch shall be applied on all exposed soil surfaces of planting areas except turf areas, creeping or rooting groundcovers, or direct seeding applications where mulch is contraindicated
4)	For soils less than 6% organic matter in the top 6 inches of soil, compost at a rate of a minimum of four cubic yards per 1,000 square feet of permeable area shall be incorporated to a depth of six inches into the soil except within the TPZ of protected trees, which shall receive 4 - 6\" of hardwood chip mulch.
5)	Water Quality Swale to be planted with hydro-seed with non-irrigated biofilter grass seed mixture.
6)	Need enough seed needed to cover 1,556 sq. ft. of swale on both sides of entrance.

Plant Legend					
BOTANICAL NAME	COMMON NAME	QTY	SIZE	WATER USE	REMARKS
TREES					
	Lagerstroemia indica 'Dynamite'	3	15 Gallon	Low	
	Cercis canadensis 'Oklahoma'	2	15 Gallon	Low	
SHRUBS AND PERENNIALS					
	Arctostaphylos 'Sunset'	28	5 Gallon	Low	
	Buxus microphylla J. 'Green Beauty'	23	5 Gallon	Low	
	Callistemon citrinus 'Little John'	10	1 Gallon	LOW	
	Juniperus scopulorum 'Skyrocket'	12	5 Gallon	Low	
	Lagerstroemia indica 'Petite Embers'	8	5 Gallon	Low	
	Nandina domestica 'Firepower'	20	1 Gallon	Low	
GROUND COVER AND GRASSES					
	Arctostaphylos 'Emerald Carpet'	11	1 Gallon	Low	
	Lomandra 'Lime Tuff'	35	1 Gallon	Low	
	Muhlenbergia rigens	12	1 Gallon	Low	

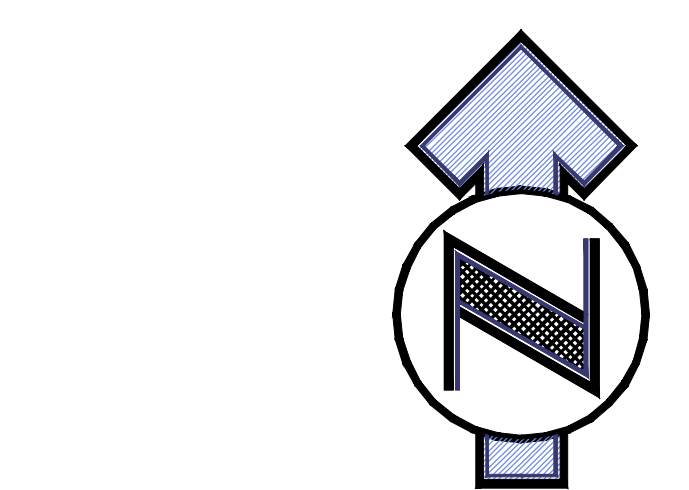
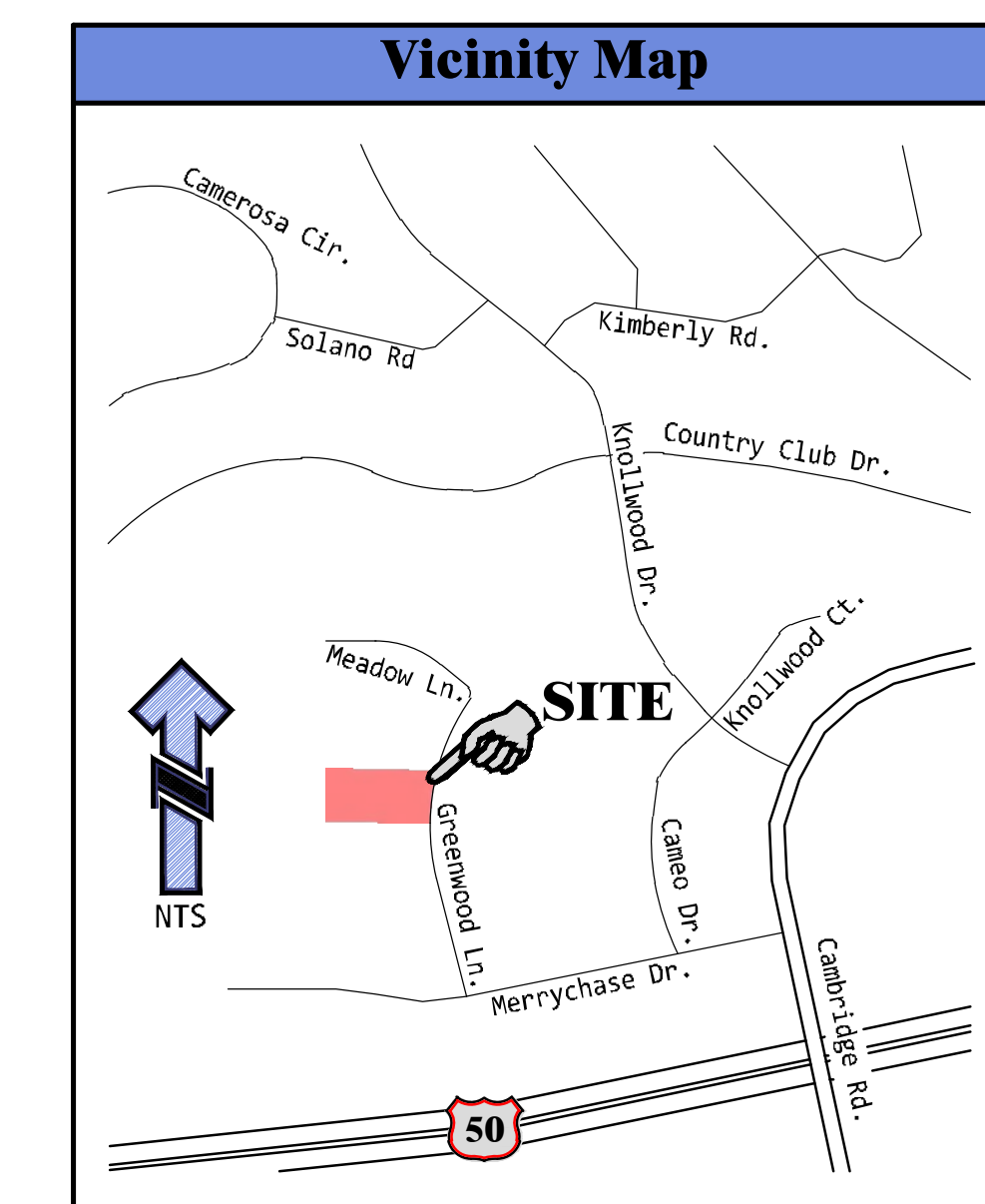

Greenwood Estates Preliminary Landscape Irrigation Plan

2545 Greenwood Lane, Cameron Park, CA 95682
Lot 46, Cameron Park North, Unit No. 5
APN: 082-411-004 - El Dorado County, CA
October 2021

WICHERT-MARLOW A CA LLC
 2006-0006985
 APN: 082-411-003
 L 45 CAMERON PK N 5
 1.03 ACRES

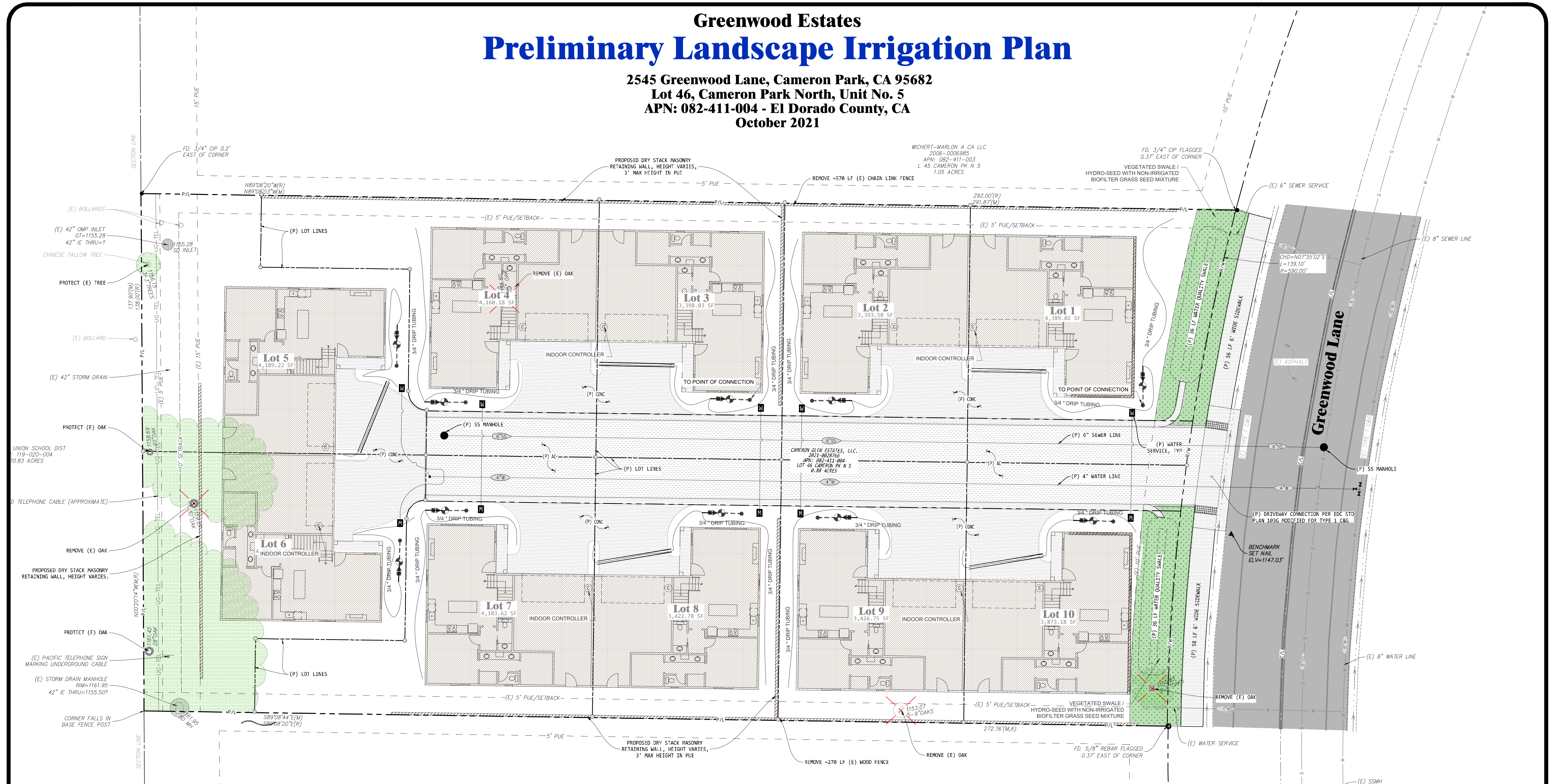

ASHWILL, BARBARA E. SUC CO TR & PRICHARD, LAUREN SUC
 2013-0003385
 APN: 082-411-011
 PM 37/110/A, CAMERON PARK NORTH, UNIT No.5
 1.00 ACRES

Notes	
1.	110 power source for irrigation controller.
2.	Mainline and control wire shall be 18" below grade.
3.	One extra control wire to all valve manifolds.
4.	Lateral lines shall be 12" below grade.
5.	Bury 3/4" tubing just under soil surface, not emitters.
6.	Place emitters on stakes for easier maintenance.
7.	1/4" tubing to be used to extend all source point emitters
8.	1/4" tubing not to exceed 19' in length for lateral tubing.
9.	Use staples to hold drip tubing.
10.	3" Layer of Shredded Bark to cover all drip lines.
11.	3" to 4" Sleeves
12.	These drawings are diagrammatic, various parts of the system may be relocated for economy and ease.
13.	Landscape contractor is responsible for all coverage.
14.	30 PSI Recommended water pressure for each drip station.
15.	Pressure regulating devices are required if water pressure is below or exceeds the recommended pressure of the specified irrigation devices.
16.	Irrigation should be avoided during windy or freezing weather or during rain.
17.	A diagram of the irrigation plan showing hydrozones shall be kept with the irrigation controller for subsequent management purposes.
18.	A Certificate of Completion shall be filled out and certified by either the designer of the landscape plans, irrigation plans, or the licensed landscape contractor for the project.
19.	An irrigation audit report by a disinterested third party shall be completed at the time of final inspection (certified by U.S. EPA water sense http://www.epa.gov/watersense/outdoor/cert_programs.html)

Irrigation Legend		
ITEM	DESCRIPTION	QTY.
DRIP TUBING	3/4" POLYTUBING DRIP TUBING	
FORMULA FOR EMITTERS	1 GAL. PLANTS / 2 - 1 GPH EMITTER PER PLANT	
	5 GAL. PLANTS / 2-2 EMITTER GPH PER PLANT	
	15 GAL. PLANTS / 3-2 GPH EMITTERS PER TREE	
PGV-75-ASV	HUNTER 3/4" ANTI SIPHON ELECTRIC VALVE WITH FLOW CONTROL	10
RAIN SENSOR	HUNTER RAIN-CLK	10
CONTROLLER	HUNTER X CORE- INDOOR-2 STATION	10
MAINLINE	1" SCH. 40 PVC PIPE / 12" BELOW SUBGRADE	
LATERAL PIPE 3/4" AND 1" SIZE	CLASS 200 PVC PIPE	
SLEEVE	3" to 4" SCHEDULE 40 PVC	
DRIP WYE FILTER	3/4" DRIP WYE FILTER	10
DRIP IN-LINE PRESSURE REDUCER	3/4" DRIP IN-LINE PRESSURE 30 PSI IN BOX	10
BALL VALVE	SHUT OFF VALVE	10

