

Copy right, Airphoto USA, LLC, All Rights Reserved. This Dipiction was compiled from unverified public and private resources and is illustrative only. No representation as to the accuracy of this information. Parcel boundaries are particularly unreliable. Users make use of this depiction at their own risk.

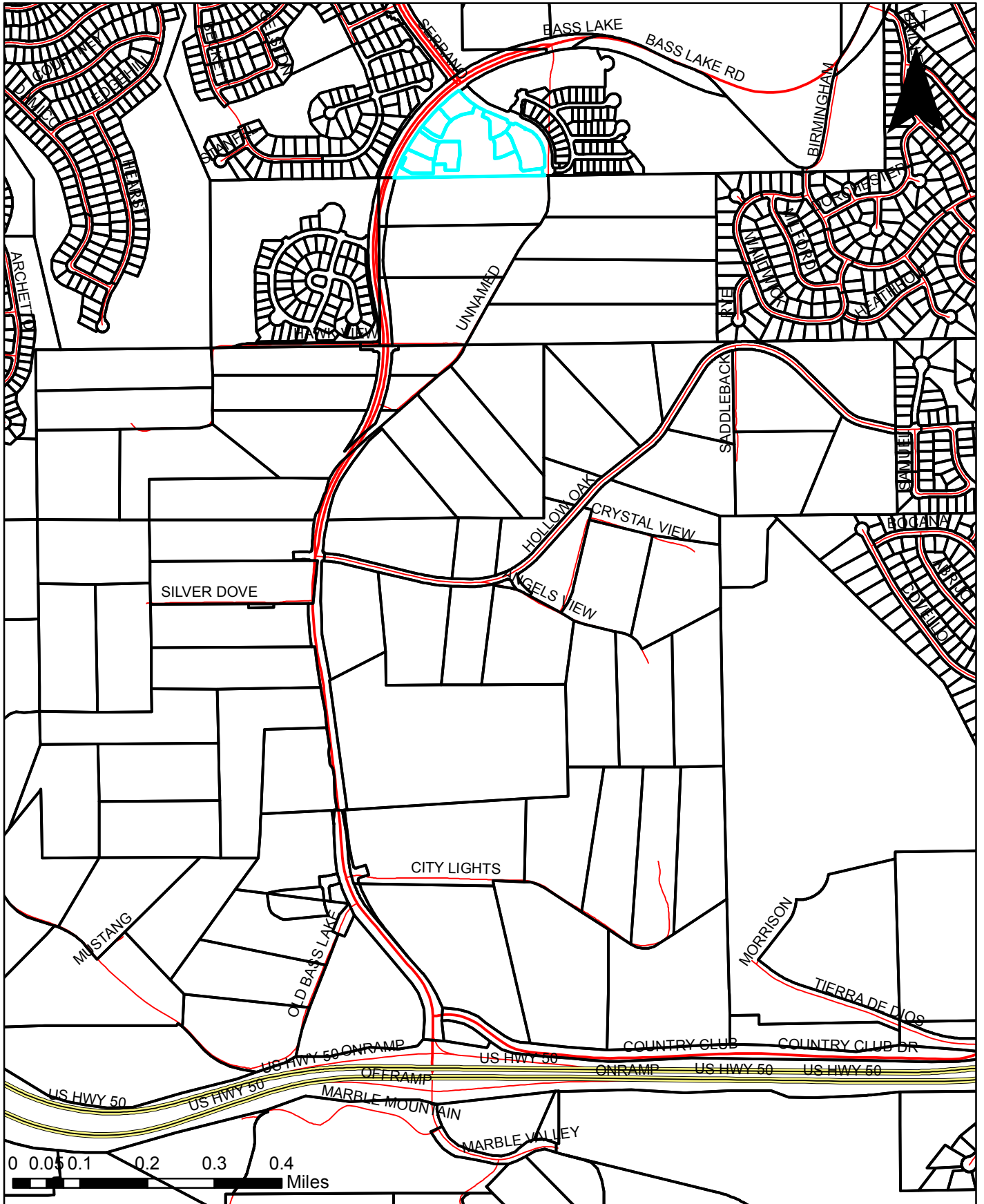
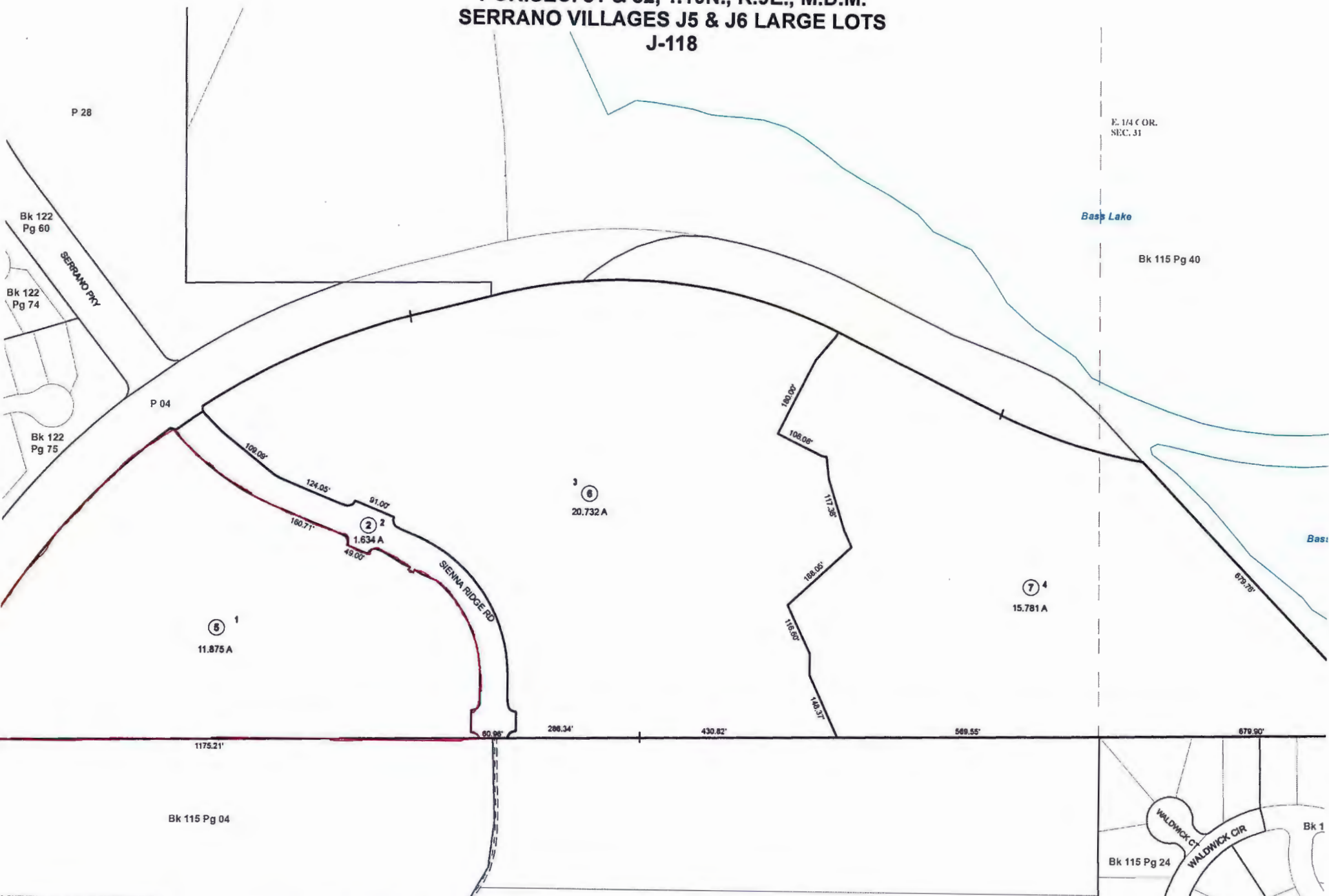

Exhibit A-Location Map

POR. SEC. 31 & 32, T.10N., R.9E., M.D.M.
SERRANO VILLAGES J5 & J6 LARGE LOTS
J-118



Acreeages Are Estimates

Adjacent Map Pages Shown in Grey Text
 Assessor's Block Numbers Shown in Ellipses
 Assessor's Parcel Numbers Shown in Circles

Exhibit B

A SURVEY. It is prepared by the El Dorado Co. for assessment purposes only. Area calculations are not guaranteed. Users should verify items and acreage.

Copy right, Airphoto USA, LLC, All Rights Reserved. This Dipiction was compiled from unverified public and private resources and is illustrative only. No representation as to the accuracy of this information. Parcel boundaries are particularly unreliable. Users make use of this depiction at their own risk.

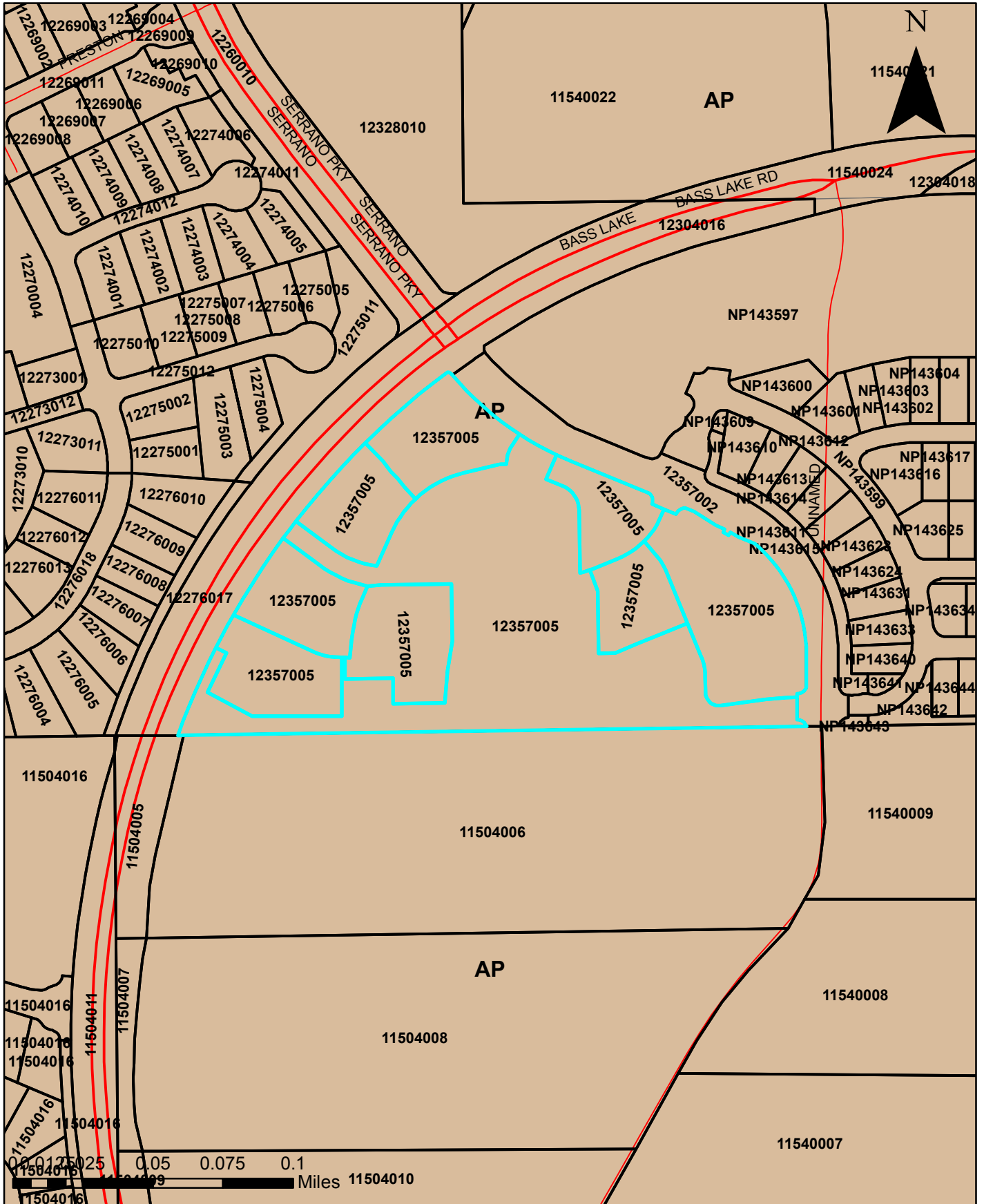

Exhibit C-General Plan Land Use Map

Copy right, Airphoto USA, LLC, All Rights Reserved. This Dipiction was compiled from unverified public and private resources and is illustrative only. No representation as to the accuracy of this information. Parcel boundaries are particularly unreliable. Users make use of this depiction at their own risk.

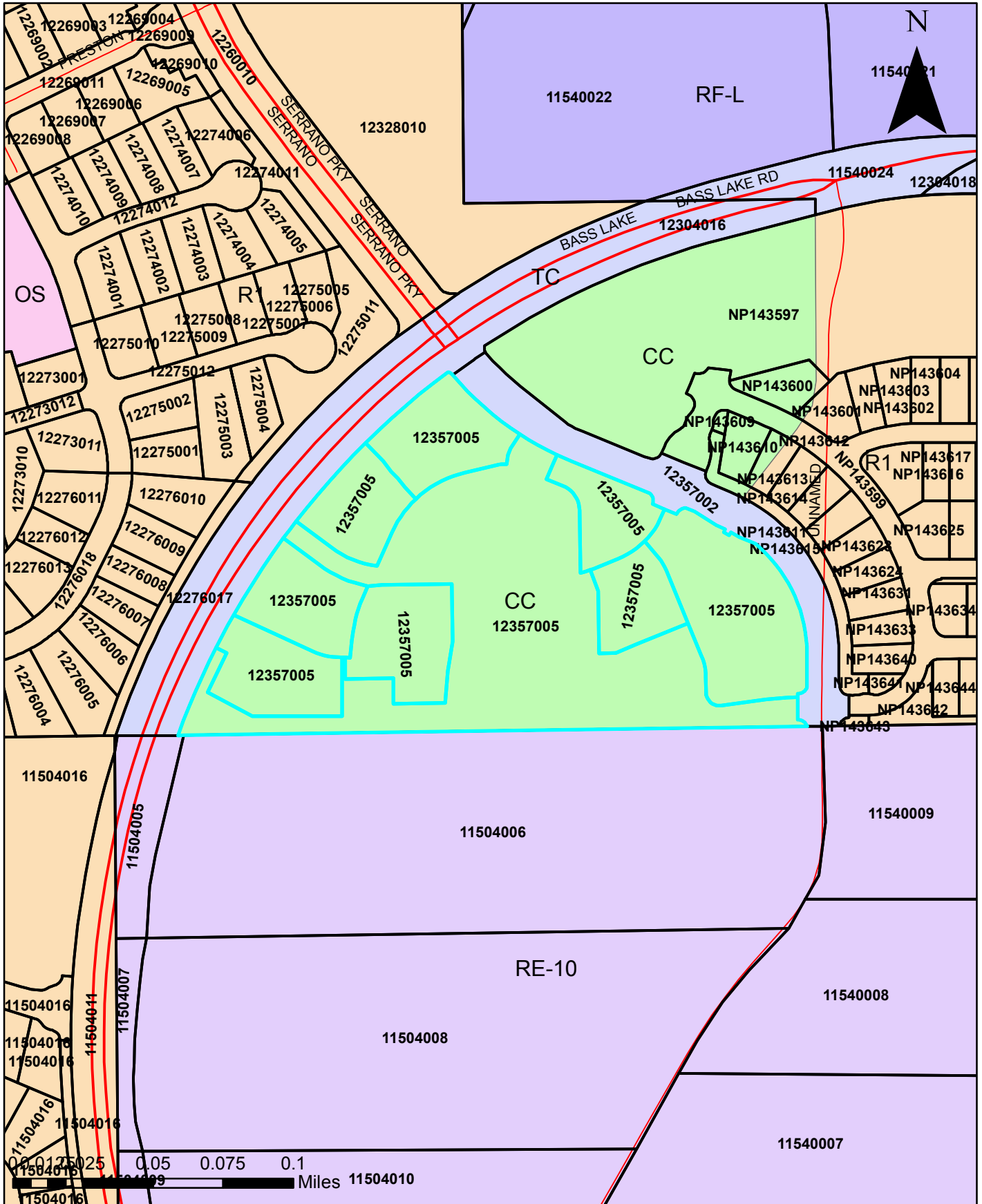

Exhibit D-Zoning Map

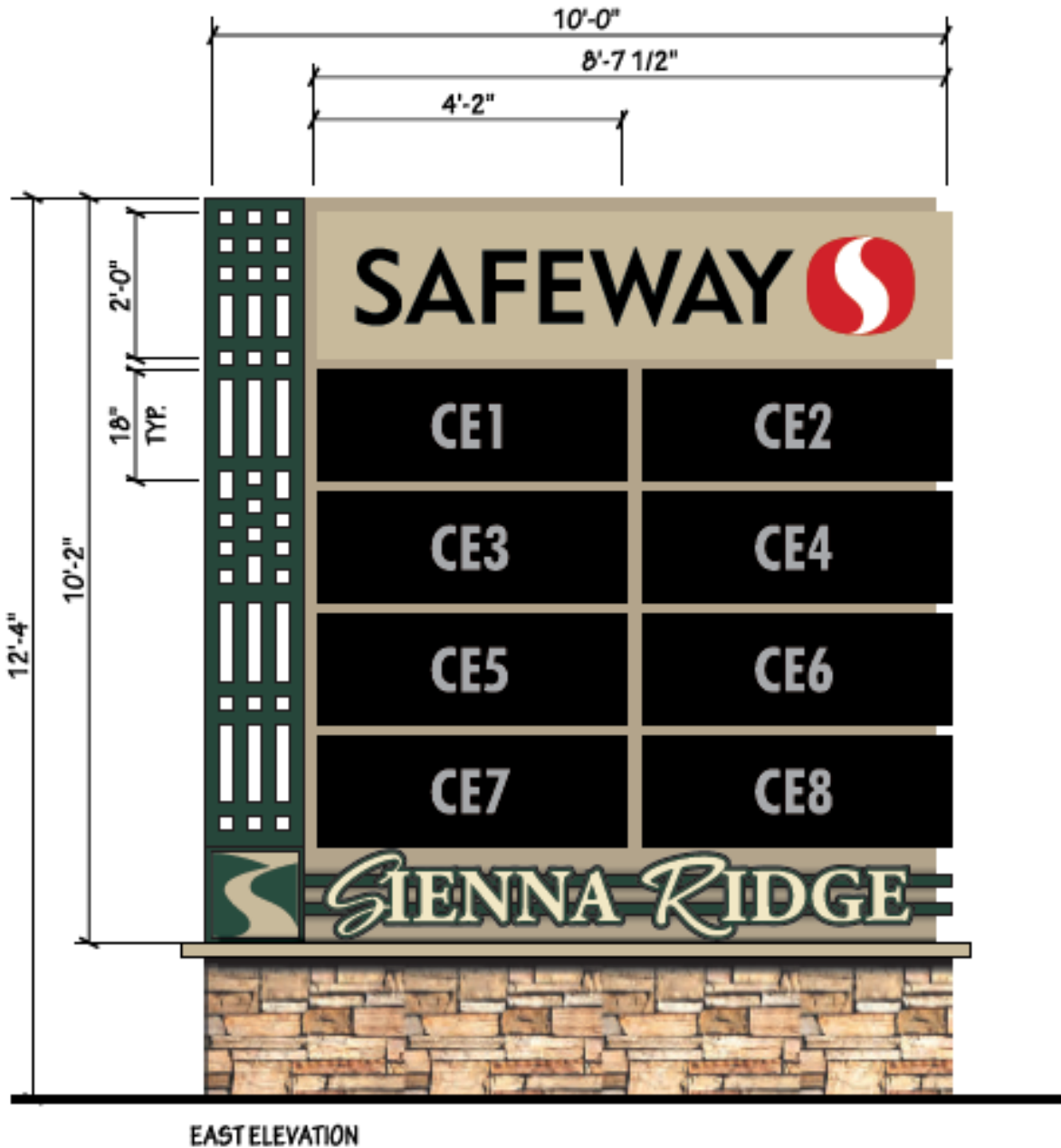

Exhibit E1-Elevations

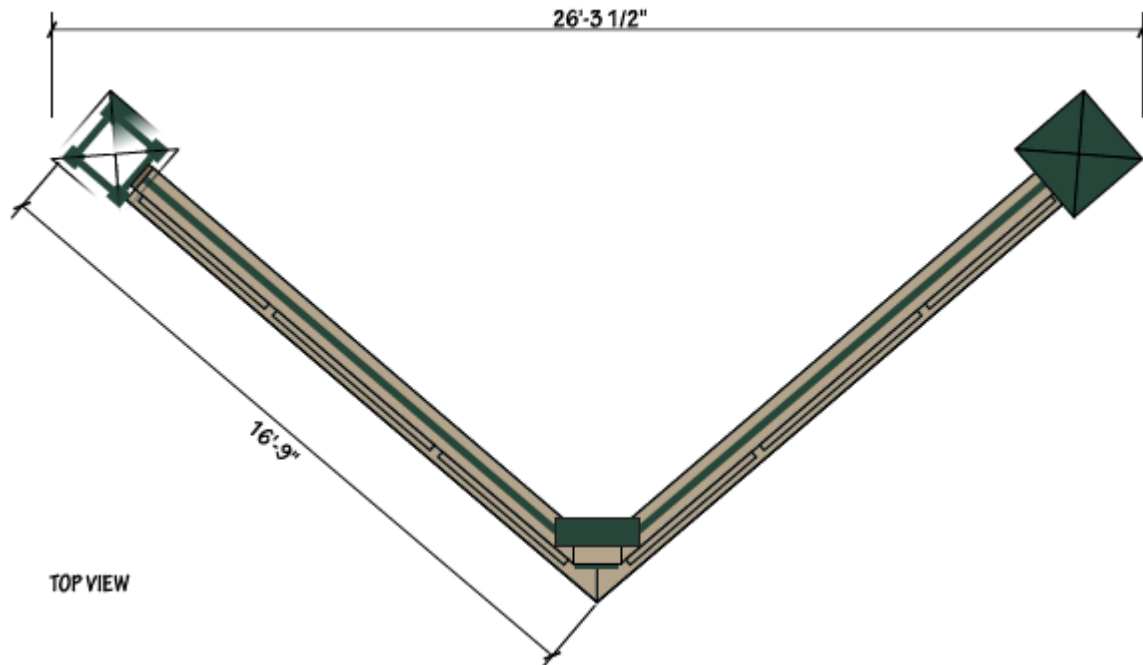
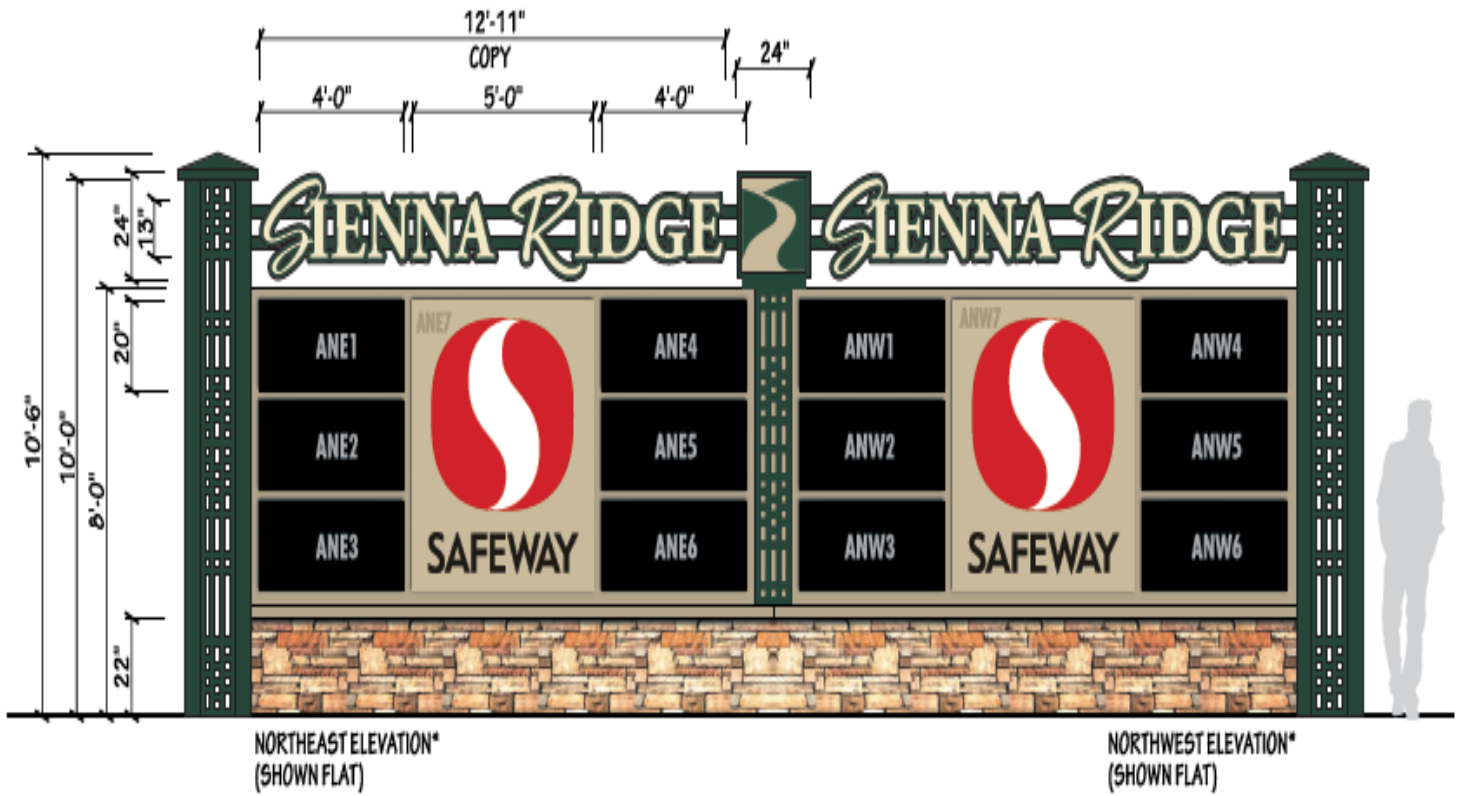

Exhibit E2-Elevations

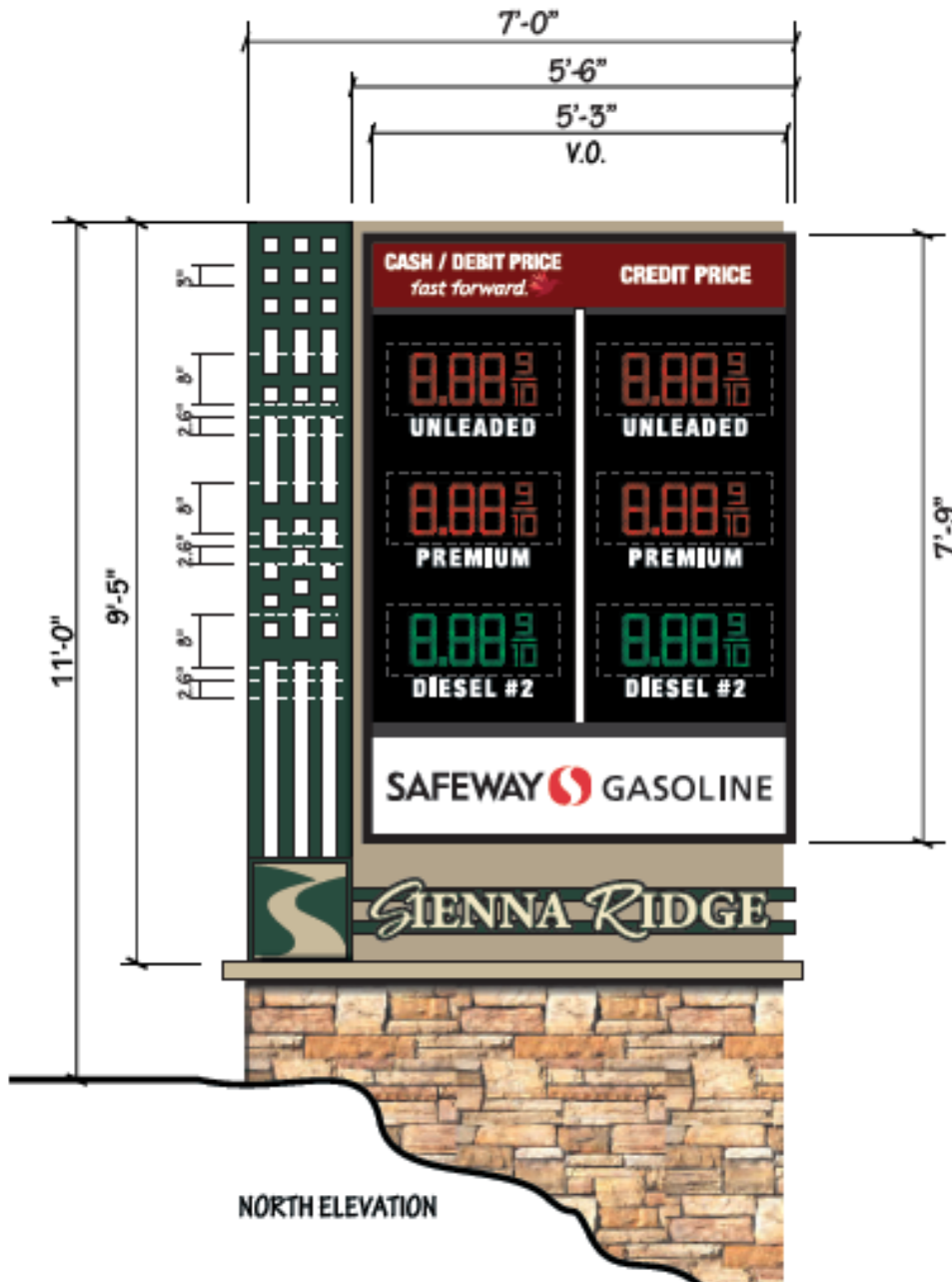

Exhibit E3-Elevations

SEWARD PARKWAY

CONCRETE
LIMITED CH
BASEMENT
WALL

REINFORCED
CONCRETE
BASEMENT
WALL

BASS LAKE ROAD

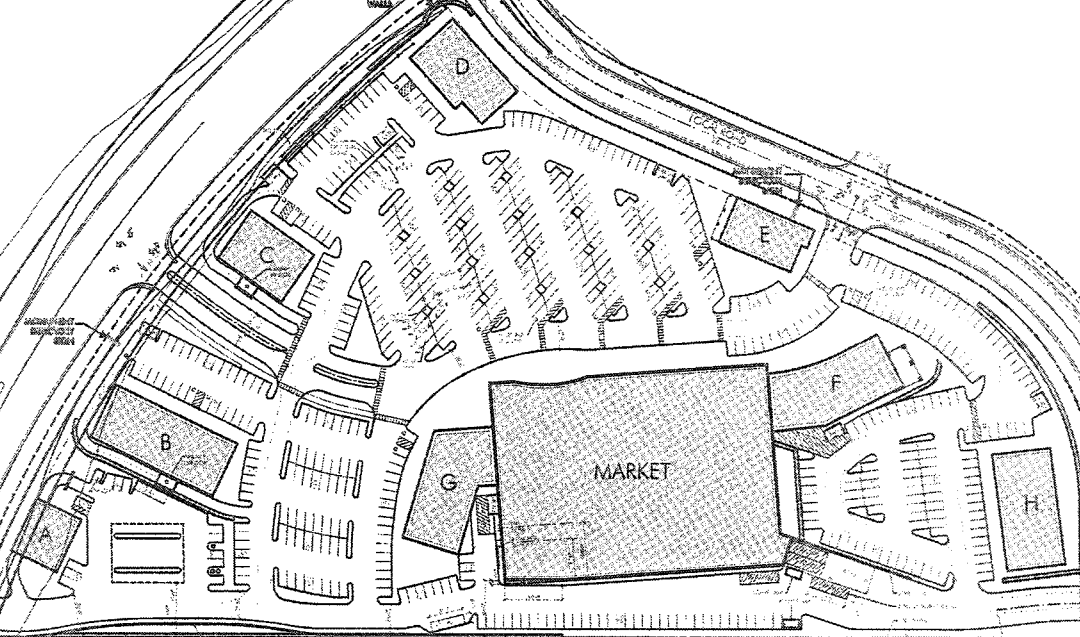

19-0340 D 8 of 31

Exhibit F-Site Plan

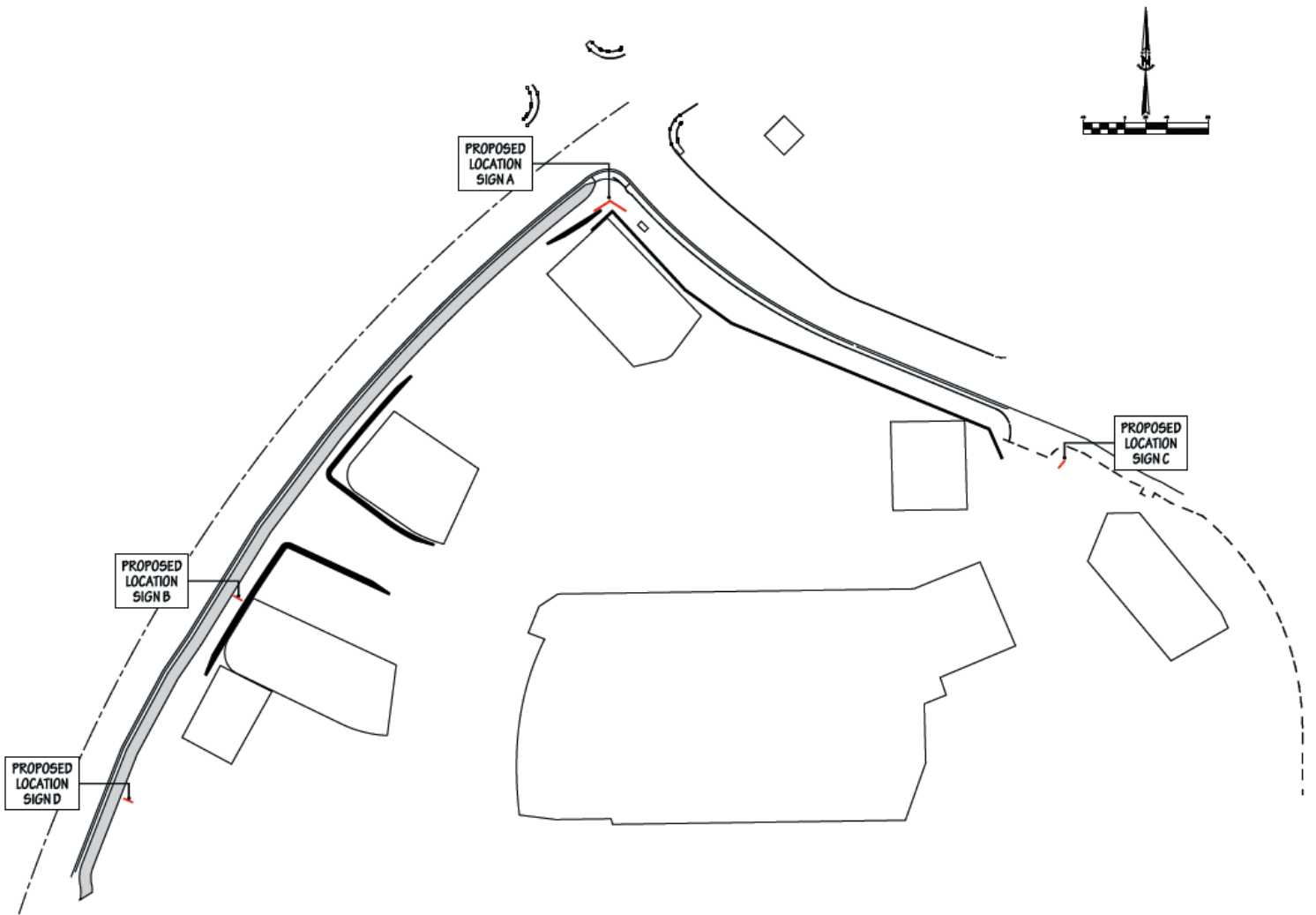

Exhibit G - Sign Location Plan

Exhibit H - Original Sign Program
SERRANO COMMERCIAL CENTER
EL DORADO HILLS, CALIFORNIA

REV. 03/23/09

GRAPHICS AND SIGNAGE CRITERIA

Introduction

This sign criteria has been established to eliminate excessive and confusing sign displays and to preserve and enhance the appearance of the Shopping Center.

The design of all signs, including style and placement of lettering, size, color, materials and methods of illumination, shall be subject to approval of the Landlord. Any installed non-conforming or unapproved sign must be brought into conformance at the non-conforming occupant's expense.

SECTION A. GENERAL REQUIREMENTS

1. Prior to applying for county approval of permits, each Tenant shall submit to the Landlord for approval before fabrication at least three copies of the following: Detailed drawings indicating the location, size, layout, design and color of the proposed sign(s), including all lettering and graphics, and an elevation of the entire façade of the tenant space showing the signage in place.
2. All county approvals and permits for signs and their installation shall be obtained by the Tenant or his representative, at his sole expense, after receiving landlord's written approval.
3. Each Tenant shall be responsible for the fulfillment of all requirements of these criteria and of government agencies with jurisdiction and approved specifications.
4. All design, installation and other work required herein shall be performed by Tenant at Tenant's sole cost and expense.
5. All work to be by qualified, licensed, and insured contractors.
6. No other signage except for that described herein is permitted.

SECTION B. DESIGN REQUIREMENTS

PART I: Size Requirements

WALL SIGNS - "MARKET" (MAJOR ANCHOR)

Maximum letter height: 84"

Maximum overall size (including logos, initial or concluding caps, ascending & descending lettering and stacked copy): 84"

Maximum length: 50% of frontage

Maximum Area: 25% of the building facade up to a maximum of 250 sf

WALL SIGNS STORES OVER 14,000 SQUARE FEET

Maximum letter height: 36"

Maximum overall size (including logos, initial or concluding caps, ascending & descending lettering and stacked copy): 48"

Maximum length: 70% of frontage

Maximum Area: 20% of the building facade up to a maximum of 200 sf

WALL SIGNS STORES UNDER 14,000 SQUARE FEET

Maximum letter height: 24"

Maximum overall size (including logos, initial or concluding caps, ascending & descending lettering and stacked copy): 36"

Maximum length: 70% of frontage

Maximum area: 20% of the building façade up to a maximum of 200 sf

APPROVED
EL DORADO COUNTY
PLANNING COMMISSION
DATE December 10, 2009
BY Roger Peterson
EXECUTIVE SECRETARY

RECEIVED
PLANNING DEPARTMENT
NOV 11 2009

STOREFRONT WINDOW SIGNS (Optional)

One sign per tenant and one additional sign for each additional storefront entrance, to be vinyl letters or gold leaf application on the storefront glass.

Maximum area of sign: 4 sf, Maximum letter height: 6"

HOURS SIGNS

"Hours" sign shall be confined to one sign space no larger than 6" high and 12" wide at each entrance, and shall not contain any sale, special announcement or other temporary information or advertising. Signage must be in white Aldine 401 Bold vinyl letters set on glass storefront.

SERVICE DOOR IDENTIFICATION

Each tenant who has a non-customer door for receiving merchandise may apply their name and address centered horizontally on the door at 5' 0" above floor level in 2" high white vinyl Aldine 401 Bold letters or as otherwise required by El Dorado County.

PART II: General Requirements for Fascia Signs

1. Tenants are allowed signage in accordance with the **El Dorado County Sign Ordinance**.
2. Wall signs will not be permitted on any elevations oriented toward "preserved open space" and residential units beyond this space, as defined by El Dorado County.
3. Signs shall be composed of individual or script lettering and may not exceed 2/3rds of the height of the area to which the sign is attached. Depth of letters shall be five inches for face lit, 3" for halo lit, illuminated with neon tubing or LED lighting, with no exposed cross-overs or raceways. Returns shall be light bronze anodized aluminum.
4. All lettering shall be individual Halo-lit reverse pan channel letters, fabricated from aluminum. Clear lexan letter backs and three inch returns. Face-lit Channel letters are acceptable only with interior 15mm neon or LED illumination, acrylic letter faces and five inch light bronze anodized aluminum returns.
5. Anchors and pad buildings are allowed individual illuminated halo and face lit letters and logos. Depth of 36" tall letters shall not exceed 5". No exposed raceways or crossovers. Acrylic face color and trim cap color to be approved by landlord.
6. All individual letters to be installed 2" away from fascia to allow halo lit illumination. Face-lit letters to be installed ½" away from building fascia to allow for proper drainage. Trim Cap color to be approved by landlord.
7. The lettering style shall be the choice of the Tenant with approval of the Landlord.
8. Graphic/decorative element or lettering may be used in addition to the lettering described above only

upon prior approval of the landlord.

9. In no case shall the wording of signs describe prices, or any type of advertising except as part of the occupant's trade name, product, service or insignia.
10. Logos will be permitted on an individual basis. Size, color, layout per landlord approval and subject to maximum letter height per Section B, Part 1 of this criteria.
11. Sign maker's labels will be permitted on the exposed surface of signs where required by the county building department. All signs must be UL approved and bear the UL label.
12. Creativity is encouraged with regard to style, size, position, length and other design characteristics, but final approval shall be subject to Landlord's sole discretion. Alternative signs to those described above may be permitted if the quality of the design and construction is acceptable to Landlord. Examples of acceptable alternative signage includes: signs incorporating three-dimensional sculptural or decorative elements. Indirectly or exterior illuminated individual letters are not acceptable.

SECTION C. INSTALLATION AND USAGE

1. No signs shall be permitted on canopy roofs or building roof.
2. All signs are required to be mounted with a raceway concealed behind the store fascia (see Exhibit A).
3. Signs shall be vertically centered on tenant's frontage and horizontally on fascia, unless building architecture warrants otherwise, subject to landlord approval.
4. No sign or any portion thereof may project above the building.
5. All penetrations of the building structure required for sign installation shall be neatly sealed in a water-tight condition.
6. No offsite signage shall be allowed.
7. No "A" frame signs shall be allowed
8. Flashing, moving or audible signs will not be permitted.
9. All attachments, conduit, conductors, transformers and other equipment shall be concealed.
10. Electrical service to all signs shall be on Tenant's meters and shall be part of Tenant's construction and operational cost.
11. All sign fastenings, bolts and clips shall comply with county building regulations..
12. The sign contractor shall be responsible for the fulfillment of all requirements and specifications, completing the installation in a professional workmanlike manner, and cleaning up, patching and painting any surfaces damaged by the installation.

SECTION D. ROADSIDE TENANT DIRECTORY MONUMENT SIGNAGE

1. Tenants may qualify for an identification panel on the illuminated roadside monument signage. Sign panels shall be Reverse Aluminum Pans, finished to match monument, with copy routed from the face and with push-thru translucent Acrylic letters with color vinyl overlays (see Exhibit B.) Monument sign locations pursuant to Exhibit D.
2. Tenant shall submit to the Landlord for approval before fabrication at least three copies of the following: Detailed drawings indicating the layout, design and color of the proposed monument panel, including all lettering and graphics.
3. Any installed non-conforming or unapproved sign must be brought into conformance at the non-conforming occupant's expense.
4. The sign contractor shall be responsible for the fulfillment of all requirements and specifications, completing the installation in a professional workmanlike manner, and cleaning up, patching and painting any surfaces damaged by the tenant panel installation.
5. There shall be maximum 36" high letters on the masonry walls at the vehicle entrances to the center ("CENTER I.D.")

SECTION E. MAINTENANCE

1. Tenant shall maintain its sign in good working order and repair to include replacement of damaged or burned out neon bulbs at Tenant's sole cost and expense. In the event Landlord notifies Tenant of an existing defect and Tenant fails to cure said defect within ten days after notification, Landlord may cause the defect to be repaired. Tenant hereby agrees to reimburse Landlord for the cost of any such repairs within ten days after the receipt of an invoice setting forth those costs incurred by Landlord.
2. Upon termination or expiration of the Lease, Tenant hereby agrees to remove its sign and repair any holes or damage to the fascia at Tenant's sole cost and expense to landlord's satisfaction. This work shall include the cost of repainting the Tenant's entire frontage in the event that during sign removal and fascia repair the tenant is unable to exactly match the original paint color.

SECTION F. GENERAL NOTES

1. All signs must be installed and operational prior to new Tenant opening for business per landlord discretion.
2. All "sale" signs, special announcements, etc., shall not be attached to the storefront glass and must be set back a minimum of 18 inches from the interior glass storefront surface.
3. Except as provided herein, no advertising placards, banners, pennants, names, insignia, trademarks or other descriptive material shall be affixed or maintained upon the glass panes and supports of the show windows and doors or upon the exterior walls of the building subject to landlord's approval.

Prepared by WESTERN SIGN COMPANY, INC., 6221-A Enterprise Dr., Diamond Springs, CA 95619 (530-622-1420).

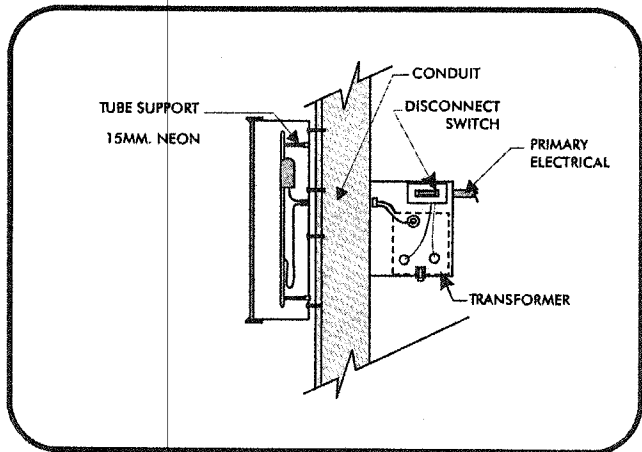

SERRANO COMMERCIAL CENTER
EL DORADO HILLS, CA
PHASE ONE

EXHIBIT B

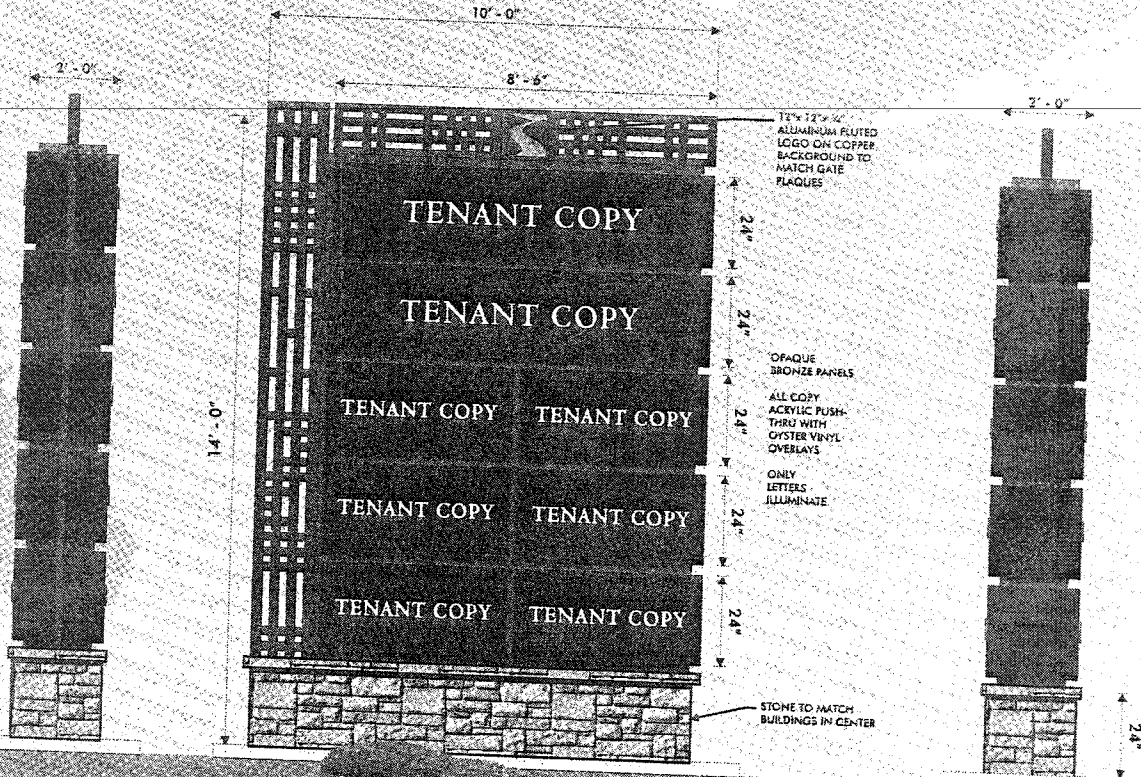

SCALE 3/8" = 1'



Western
SIGN COMPANY, INC.

6221 Enterprise Drive Diamond Springs, CA 95619
Phone 916 933-3766 • 530 822-1420 • Fax 530 822-6367

SERRANO COMMERCIAL CENTER
EL DORADO HILLS, CA
PHASE ONE

EXHIBIT C-1

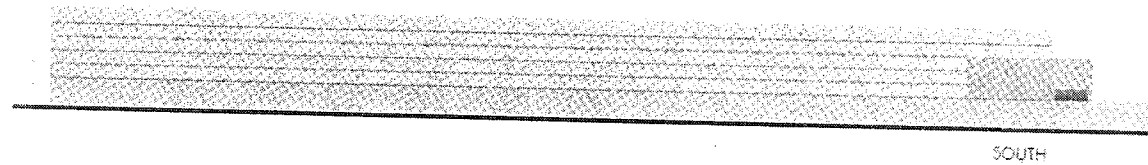
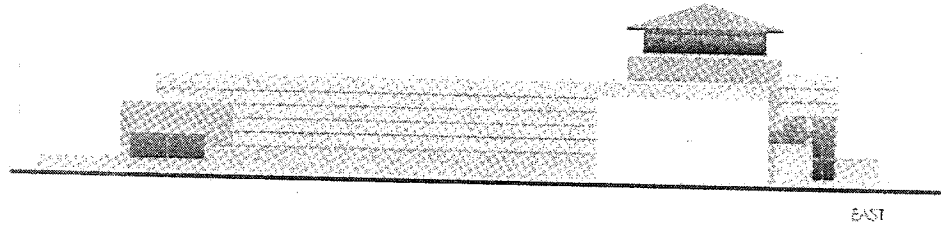
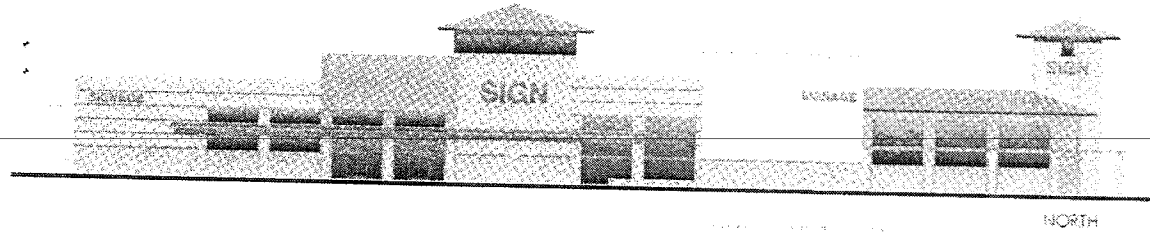

MARKET

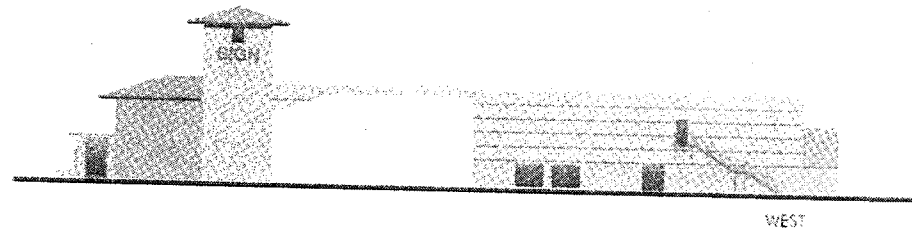

Western

6221 Enterprise Drive, Diamond Springs, CA 95619
Phone 916 953-3765 • 530 622-1420 • Fax 530 622-9367

SERRANO COMMERCIAL CENTER
EL DORADO HILLS, CA
PHASE ONE

EXHIBIT C-2

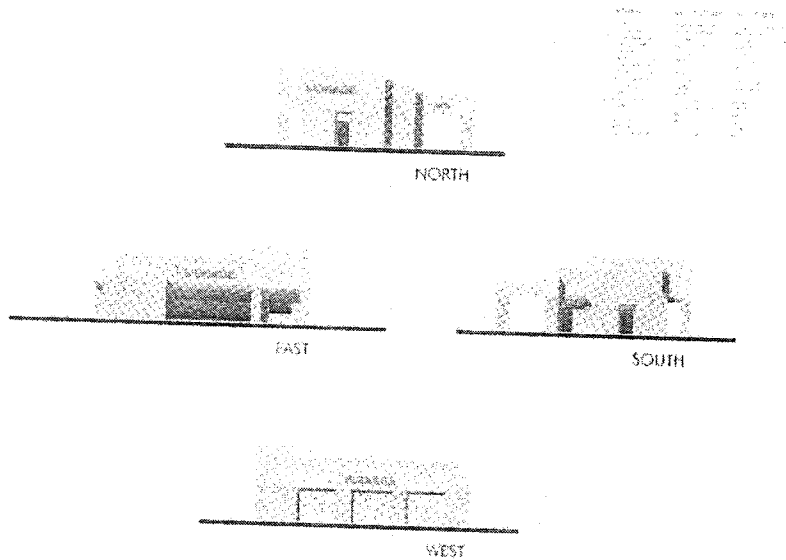

BUILDING A

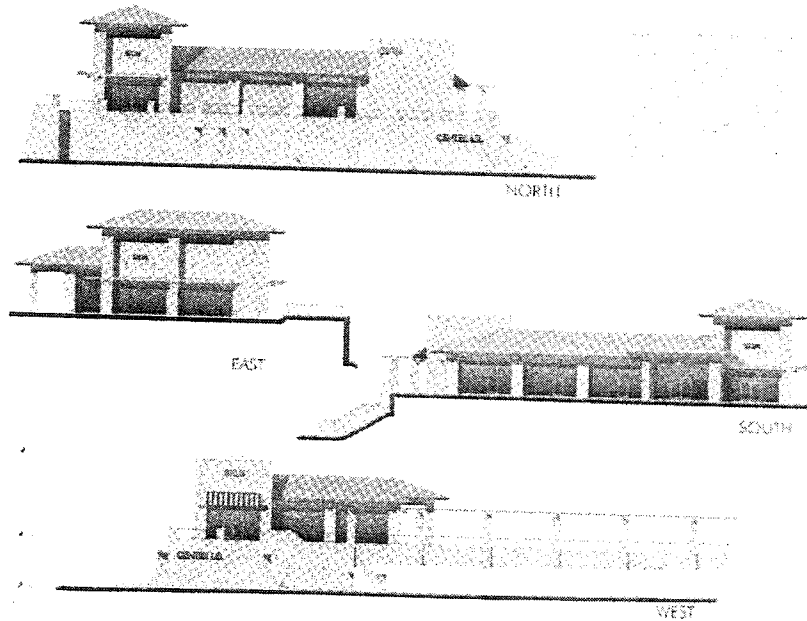

BUILDING D

SERRANO COMMERCIAL CENTER
EL DORADO HILLS, CA
PHASE ONE

EXHIBIT C-3

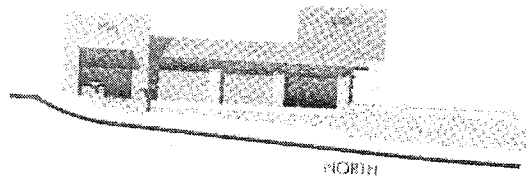

NORTH



EAST

SOUTH

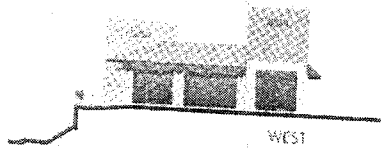

WEST

BUILDING E

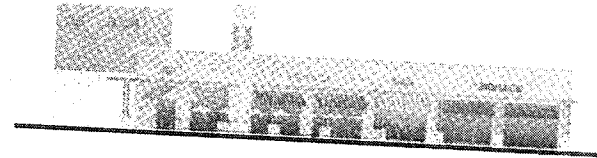

NORTH

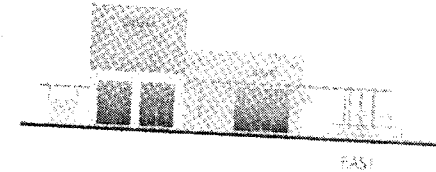

EAST

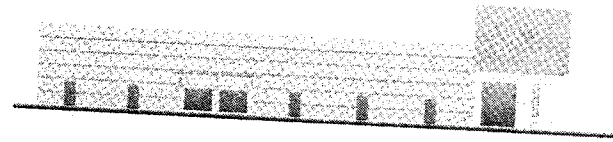

SOUTH

BUILDING F



5231 Enterprise Drive Diamond Springs, CA 95819
Phone 916 933-3755 • 530 622-1420 • Fax 530 622-3367

SERRANO COMMERCIAL CENTER
EL DORADO HILLS, CA
PHASE ONE

EXHIBIT C-4

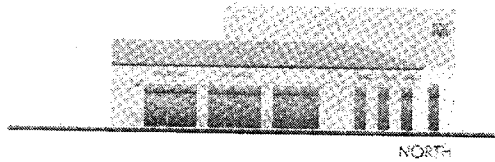

NORTH

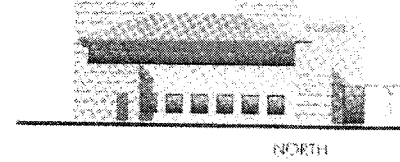

NORTH

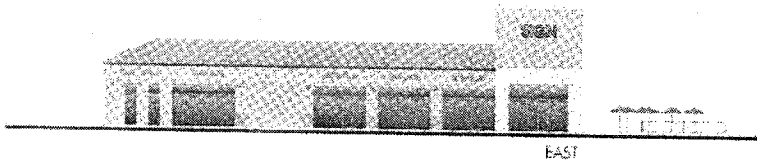

EAST

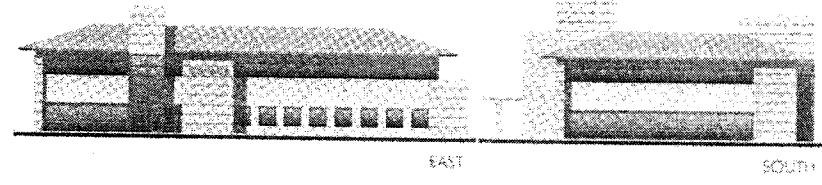

EAST

SOUTH

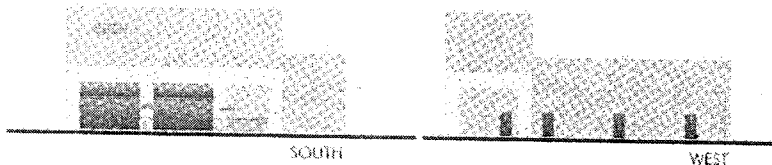

SOUTH

WEST

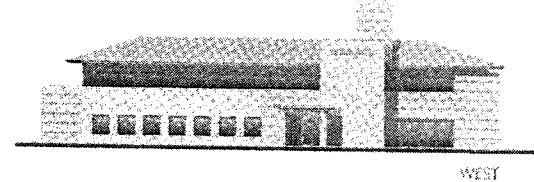

WEST

BUILDING G

BUILDING H



Western
CONCRETE COMPANY, INC.

6221 Enterprise Drive Diamond Springs, CA 95619
Phone 916 933-3765 • 530 622-1420 • Fax 930 622-6367

SERRANO COMMERCIAL CENTER
EL DORADO HILLS, CA
PHASE ONE

EXHIBIT D

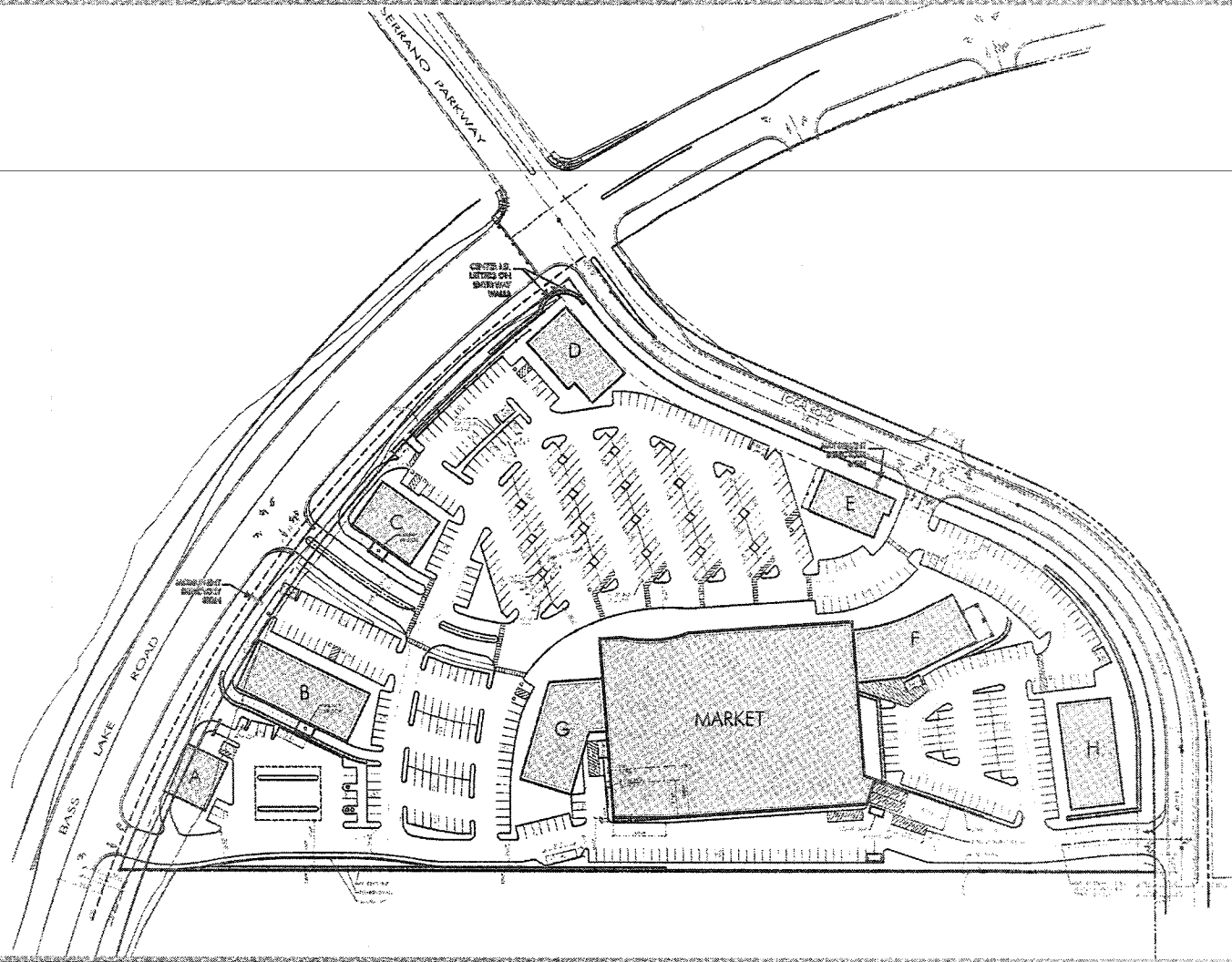

Western
SOUTH COMPANY, INC.

8221 Enterprise Drive Diamond Springs, CA 95618
Phone 916 933-3765 • 530 822-1420 • Fax 530 822-9367

Exhibit I

PROPOSED

**PLANNED SIGN PROGRAM
FOR
SIENNA RIDGE
EL DORADO HILLS, CALIFORNIA**

LANDLORD

Donahue Schriber Realty Group, LP.
3501 Del Paso Road, Suite 100
Sacramento, CA 95835
(916) 920-5555

June 28, 2018

SIGN PROGRAM
FOR
SIENNA RIDGE
EL DORADO HILLS, CALIFORNIA

A. PURPOSE AND INTENT

This sign criteria has been established to eliminate excessive and confusing sign displays and to preserve and enhance the appearance of the Shopping Center. Flexibility of design is encouraged but at the same time overall visual harmony is maintained.

The design of all signs, including style and placement of lettering, size, color, materials and methods of illumination, shall be subject to approval of the Landlord and El Dorado County. Any non-conforming or unapproved sign must be brought into conformance at the expense of the Tenant.

B. GENERAL CRITERIA

1. Prior to fabrication of any sign in the center, the Tenant shall submit to the Landlord for the following: Detailed drawings indicating the location, size, layout, design, materials, and color of the proposed sign(s), including all lettering and graphics, and an elevation of the entire facade of the Tenant space showing the signage in place. This approval must be obtained prior to submittal to the El Dorado County.
2. Prior to installation and fabrication of any sign, all county approvals and permits for signs and their installation shall be obtained by the Tenant or his representative, at his sole expense, after receiving Landlord's written approval.
3. Each Tenant shall be responsible for the fulfillment of all requirements of these criteria and of government agencies with jurisdiction and approved specifications.
4. All design, installation and other work required herein shall be performed by Tenant at Tenant's sole cost and expense.
5. All work to be done by qualified, licensed, and insured contractors. Each Tenant shall be responsible for and repair any damage to any surface caused by the signage or its' installation.
6. Landlord reserves the right to periodically hire an independent electrical engineer, at Tenant's sole expense, to inspect the installation of all Tenant's signs. Tenants will be required to have any discrepancies and/or code violations corrected at Tenant's expense. Any code violations, requests for sign removals, or discrepancies not corrected within fifteen (15) days of notice, may be corrected by the Landlord at Tenant's expense.

C. PROHIBITED SIGNS

1. Temporary signs, window signs, placards, flags, pennants, and banners of any type shall be prohibited, except as otherwise previously approved by Landlord and the El Dorado County prior to installation.
2. No animated, flashing, moving, audible, off-premise, A-Frame, or vehicle signs shall be allowed.
3. No exposed raceways, crossovers, conduits, neon tube conductors, transformers are allowed.

D. GENERAL SIGN REQUIREMENTS – FASCIA SIGNS

1. Tenants are allowed signage in accordance with the El Dorado County Sign Ordinance.
2. Signs shall be composed of individual or script lettering and may not exceed 2/3rds of the height of the area to which the sign is attached. Depth of letters shall be five inches for face lit, 3" for halo lit, illuminated with neon tubing or LED lighting, with no exposed cross overs or raceways. Returns shall be light bronze anodized aluminum.
3. All lettering shall be individual or Halo-lit reverse pan channel letters, fabricated from aluminum. Clear Lexan letter backs and three inch returns. Face-lit Channel letters are acceptable only with interior 15mm neon or LED illumination, acrylic letter faces and five inch light bronze anodized aluminum returns.
4. Anchors and pad buildings are allowed individual illuminated halo and face lit letters and logos. Depth of 36" tall letters shall not exceed 5". No exposed raceways or crossovers. Acrylic face color and trim cap color to be approved by Landlord.
5. All individual letters to be installed 2" away from fascia to allow halo lit illumination. Face-lit letters to be installed 1/2" away from building fascia to allow for proper drainage. Trim Cap color to be approved by Landlord.
6. The lettering style shall be the choice of the Tenant with approval of the Landlord.
7. Graphic/decorative element or lettering may be used in addition to the lettering described above only upon prior approval of the Landlord.
8. In no case shall the wording of signs describe prices, or any type of advertising except as part of the occupant's trade name, product, service, insignia or as otherwise approved by Landlord in writing.
9. Logos will be permitted on an individual basis. Size, color, layout per Landlord approval and subject to maximum letter height per Section F of this Criteria.
10. Sign maker's labels will be permitted on the exposed surface of signs only when required by the county building department. All signs must be UL approved and bear the UL label.

11. Creativity is encouraged regarding style, size, position, length and other design characteristics, but final approval shall be subject to Landlord's sole discretion. Alternative signs to those described above may be permitted if the quality of the design and construction is acceptable to Landlord. Examples of acceptable alternative signage includes: signs incorporating three dimensional sculptural or decorative elements. Indirectly or exterior illuminated individual letters are not acceptable.

E. INSTALLATION AND USAGE

1. No signs shall be permitted on canopy roofs or building roof.
2. All signs are required to be mounted with a raceway concealed behind the store fascia (see Exhibit A).
3. Signs shall be vertically centered on Tenant's frontage and horizontally on fascia, unless building architecture warrants otherwise, subject to Landlord approval.
4. No sign or any portion thereof may project above the building.
5. All penetrations of the building structure required for sign installation shall be neatly sealed in a water tight condition.
6. All attachments, conduit, conductors, transformers and other equipment shall be concealed.
7. Tenant's sign contractor shall completely install and connect sign display and primary wiring at sign location per Landlord's approval. Signs are to be connected to the J-box provided by the Landlord, which is connected to Landlord's house panel for uniform control hours of illumination unless otherwise directed by Landlord.
8. All sign fastenings, bolts and clips shall comply with county building regulations.
9. The sign contractor shall be responsible for the fulfillment of all requirements and specifications, completing the installation in a professional workmanlike manner, and cleaning up, patching and painting any surfaces damaged by the installation.

F. SIGN TYPES

TYPE 1 – WALL SIGNS – “MARKET” (MAJOR ANCHOR)

Maximum letter height: 84”

Maximum overall size (including logos, initial or concluding caps, ascending & descending lettering and stacked copy): 84”

Maximum length: 50% of frontage

Maximum Area: 25% of the building facade up to a maximum of 250 sf

TYPE 2 – WALL SIGNS STORES OVER 14,000 SQUARE FEET

Maximum letter height: 36”

Maximum overall size (including logos, initial or concluding caps, ascending and descending lettering and stacked copy): 48”

Maximum length: 70% of frontage

Maximum area: 20% of the building facade up to a maximum of 200 sf

Type 3 – WALL SIGNS STORES UNDER 14,000 SQUARE FEET

Maximum letter height: 24"

Maximum overall size (including logos, initial or concluding caps, ascending and descending lettering and stacked copy): 36"

Maximum length: 70% of frontage

Maximum area: 20% of the building facade up to a maximum of 200 sf

TYPE 4 – BUSINESS IDENTIFICATION – TOWER SIGNS

Maximum letter height: 30"

Maximum overall size (including logos, initial or concluding caps, ascending and descending lettering and stacked copy): 36"

Maximum length: 80% of tower width

Maximum Area: up to a maximum of 200 sf

TYPE 5 – ROADSIDE TENANT DIRECTORY MONUMENT SIGNAGE

Tenants may qualify for an identification panel on the illuminated roadside monument signage. Sign panels shall be Reverse Aluminum Pans, finished to match monument, with copy routed from the face and with push thru translucent Acrylic letters with color vinyl overlays (see Exhibit B & B-1.) Monument sign locations pursuant to Exhibit C.

TYPE 6 – FUEL CENTER (SIGN D)

A pricing sign for a fuel center is permitted provided said sign is: (1) subject to the El Dorado County Code and (2) the design is consistent with sign shown on Exhibit B-2.

G. MISCELLANEOUS

1. STOREFRONT WINDOW SIGNS (OPTIONAL)

One sign per Tenant and one additional sign for each additional storefront entrance, to be vinyl letters or gold leaf application on the storefront glass.

Maximum area of sign: 4 sf

Maximum letter height: 6"

2. HOURS SIGNS

"Hours" sign shall be confined to one sign space no larger than 6" high and 12" wide at each entrance, and shall not contain any sale, special announcement or other temporary information or advertising. Signage must be in white Aldine 401 Bold vinyl letters set on glass storefront.

3. SERVICE DOOR IDENTIFICATION

Each Tenant who has a non-customer door for receiving merchandise may apply their name and address centered horizontally on the door at 5' 0" above floor level in 2" high white vinyl Aldine 401 Bold letters or as otherwise required by El Dorado County.

4. DRIVE-THROUGH RESTAURANT MENU BOARDS

Pad Tenant with drive-through facilities shall be allowed one menu-board per drive through entrance subject to El Dorado County sign code.

5. DRIVE-THROUGH DIRECTIONAL SIGNS

Pad Tenant shall be allowed four (4) directional signs, subject to restrictions of El Dorado County Sign Code, each not exceeding four (4) square feet in area and a height of four (4) feet. Said directional sign shall contain only that information necessary for on-site circulation, parking and site information without any advertising. All costs associated with the installation of these signs including any electrical requirements shall be at the sole cost of the Pad Tenant.

H. MAINTENANCE

1. Tenant shall maintain its sign in good working order and repair to include replacement of damaged or burned out neon bulbs at Tenant's sole cost and expense. In the event Landlord notifies Tenant of an existing defect and Tenant fails to cure said defect within ten days after notification, Landlord may cause the defect to be repaired. Tenant hereby agrees to reimburse Landlord for the cost of any such repairs within ten days after the receipt of an invoice setting forth those costs incurred by Landlord.
2. Upon termination or expiration of the Lease, Tenant hereby agrees to remove its sign and repair any holes or damage to the fascia at Tenant's sole cost and expense to Landlord's satisfaction. This work shall include the cost of repainting the Tenant's entire frontage if during sign removal and fascia repair the Tenant is unable to exactly match the original paint color.

I. APPROVALS

1. To obtain Landlord's approval, submit a copy as outlined in Section B of this Criteria, to the Landlord at the following address:

Donahue Schriber Realty Group, L.P.
3501 Del Paso Road, Suite #100
Sacramento, CA 95835
Attn: Dave Murray
2. Please allow approximately two (2) weeks for the approval process. Upon approval, a letter shall be provided to Tenant by Landlord. This letter must be presented to the El Dorado County to obtain the Tenant's sign permit.
3. Prior to the manufacturing of any sign, the Tenant shall obtain a sign permit from El Dorado County.

J. GENERAL NOTES

1. All signs must be installed and operational prior to new Tenant opening for business per Landlord discretion.
2. All "sale" signs, special announcements, etc., shall not be attached to the storefront glass and must be set back a minimum of eighteen (18) inches from the interior glass storefront surface.
3. Except as provided herein, no advertising placards, banners, pennants, names, insignia, trademarks or other descriptive material shall be affixed or maintained upon the glass panes and supports of the show windows and doors or upon the exterior walls of the building subject to Landlord's approval.

EXHIBIT A

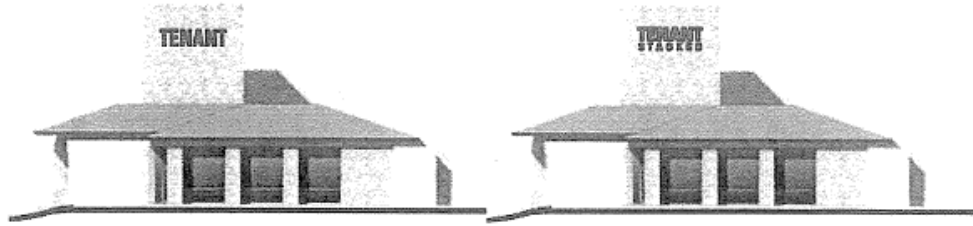

STORES OVER 14,000 SQUARE FEET

Maximum letter height: 36"
 Maximum Overall Size: 48"
 Maximum length: 70% of frontage
 Maximum Area: 200 sf



STORES UNDER 14,000 SQUARE FEET

Maximum letter height: 24"
 Maximum Overall Size: 36"
 Maximum length: 70% of frontage
 Maximum Area: 200 sf



SCALE 1/4" = 1' - 0"

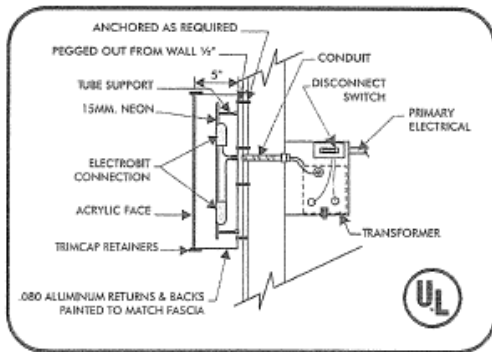

LETTER DETAIL - NEON
 FACE LIT

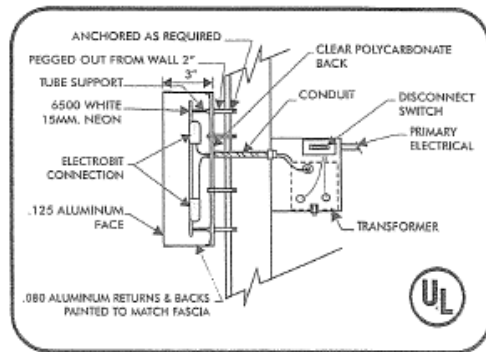

LETTER DETAIL - NEON
 HALO LIT REVERSE PAN

EXHIBIT B
(Sign B & C)

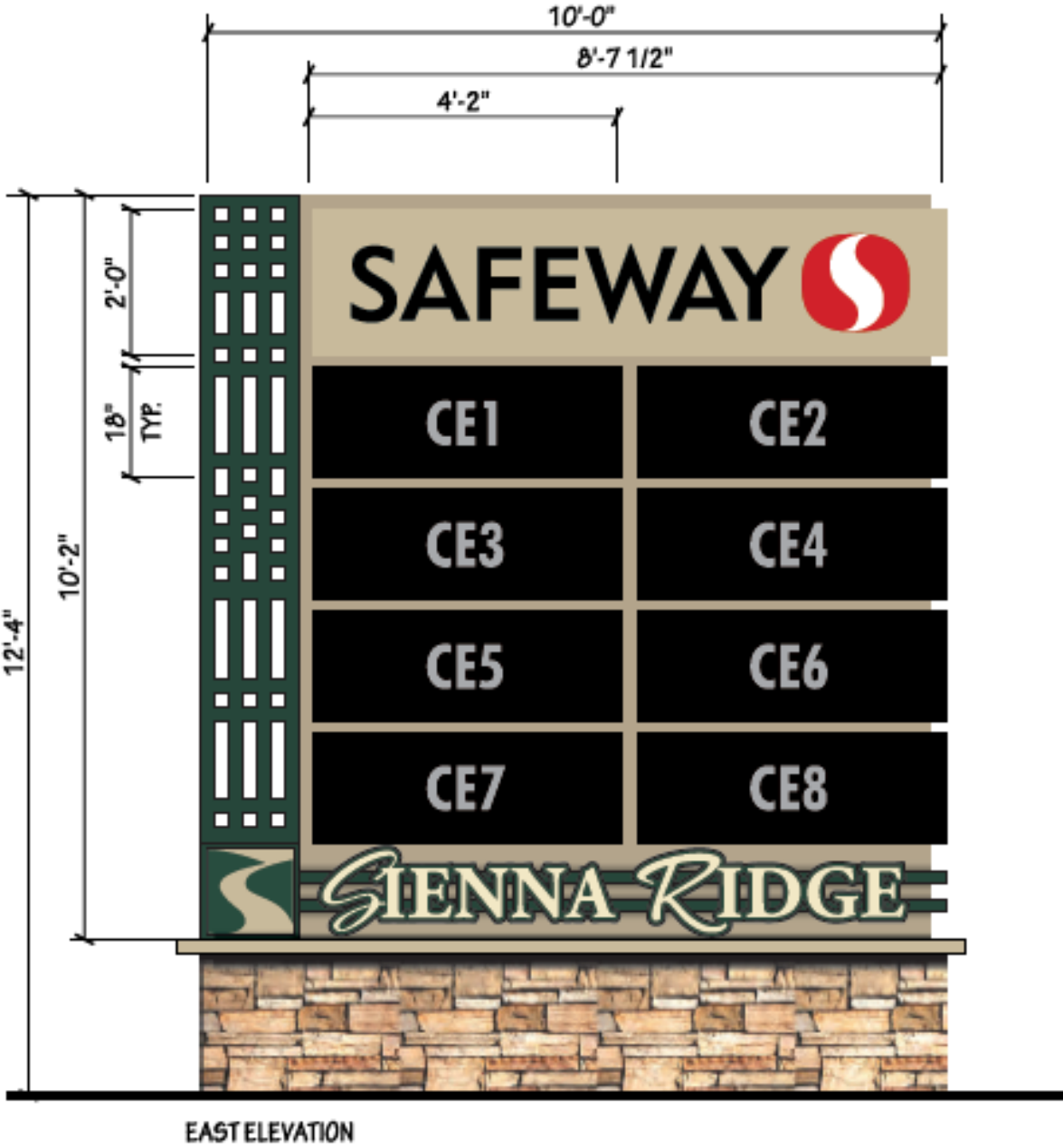

EXHIBIT B-1
(Sign A)

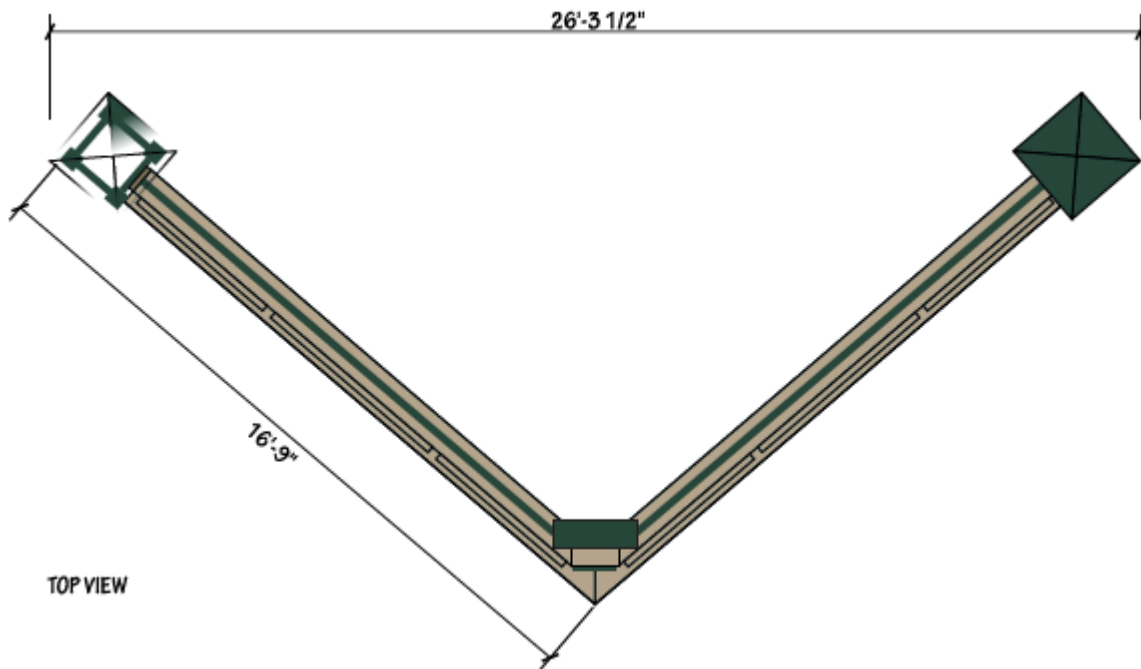
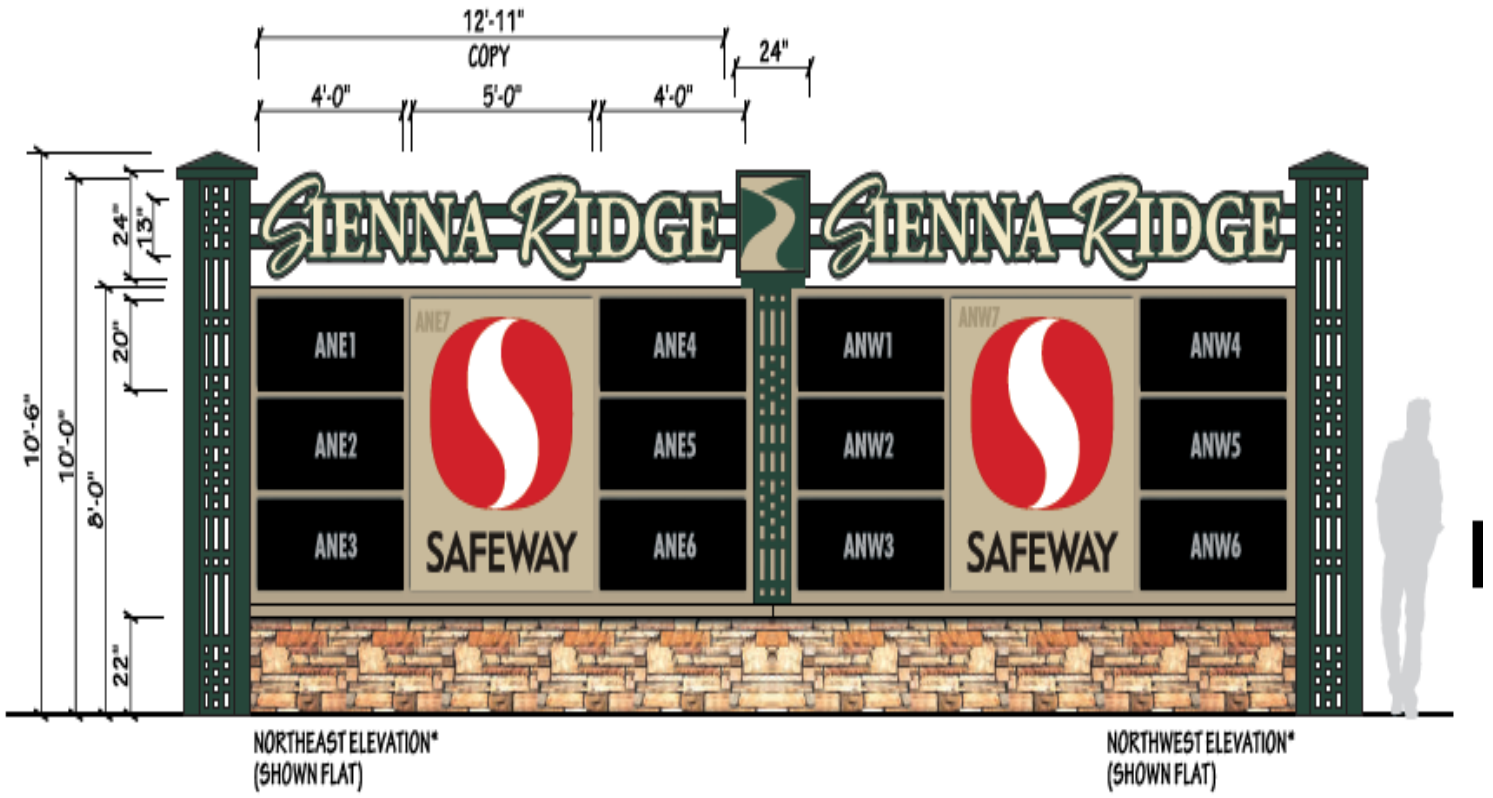

EXHIBIT B-2
(Sign D)

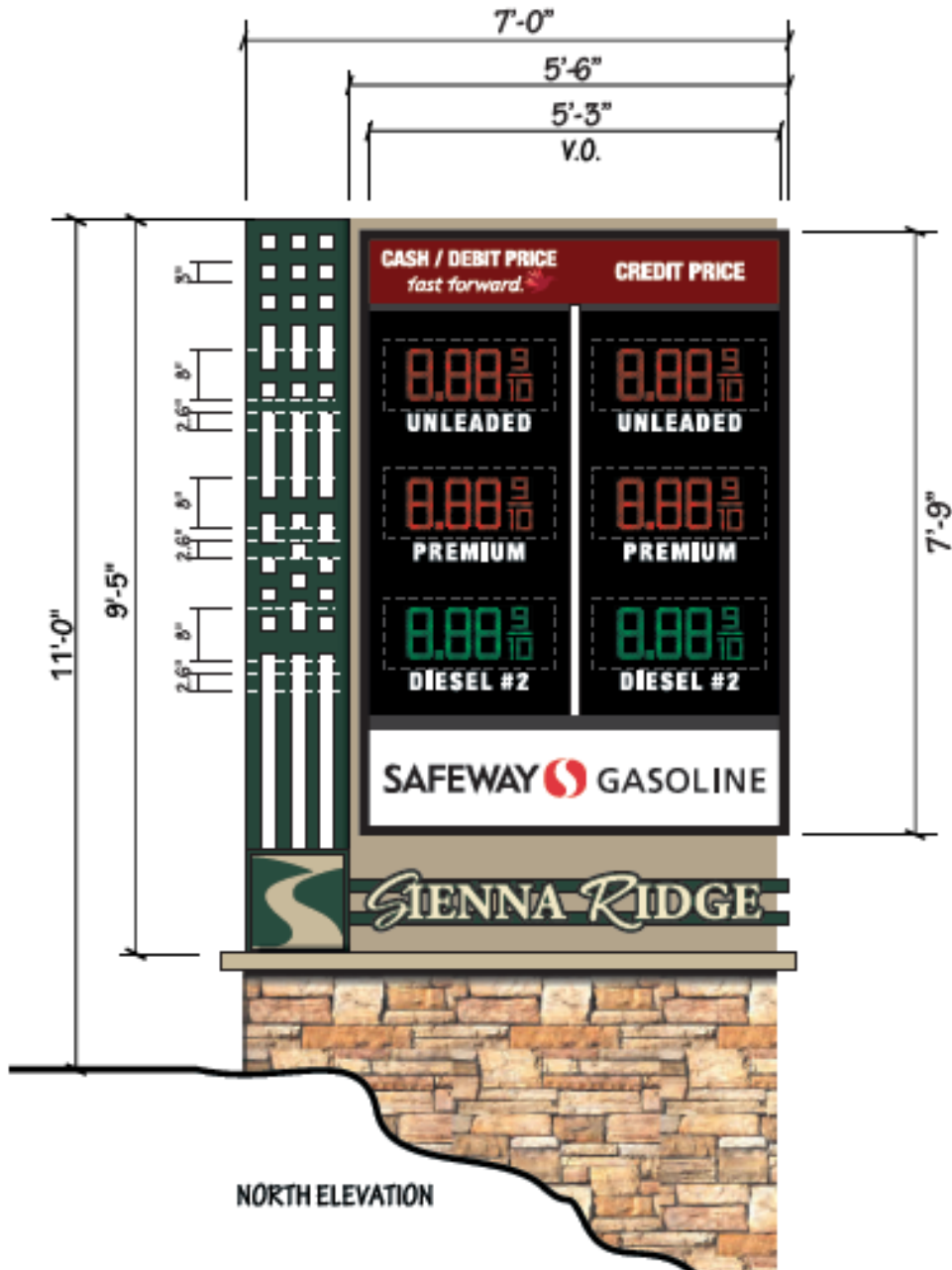

EXHIBIT C

