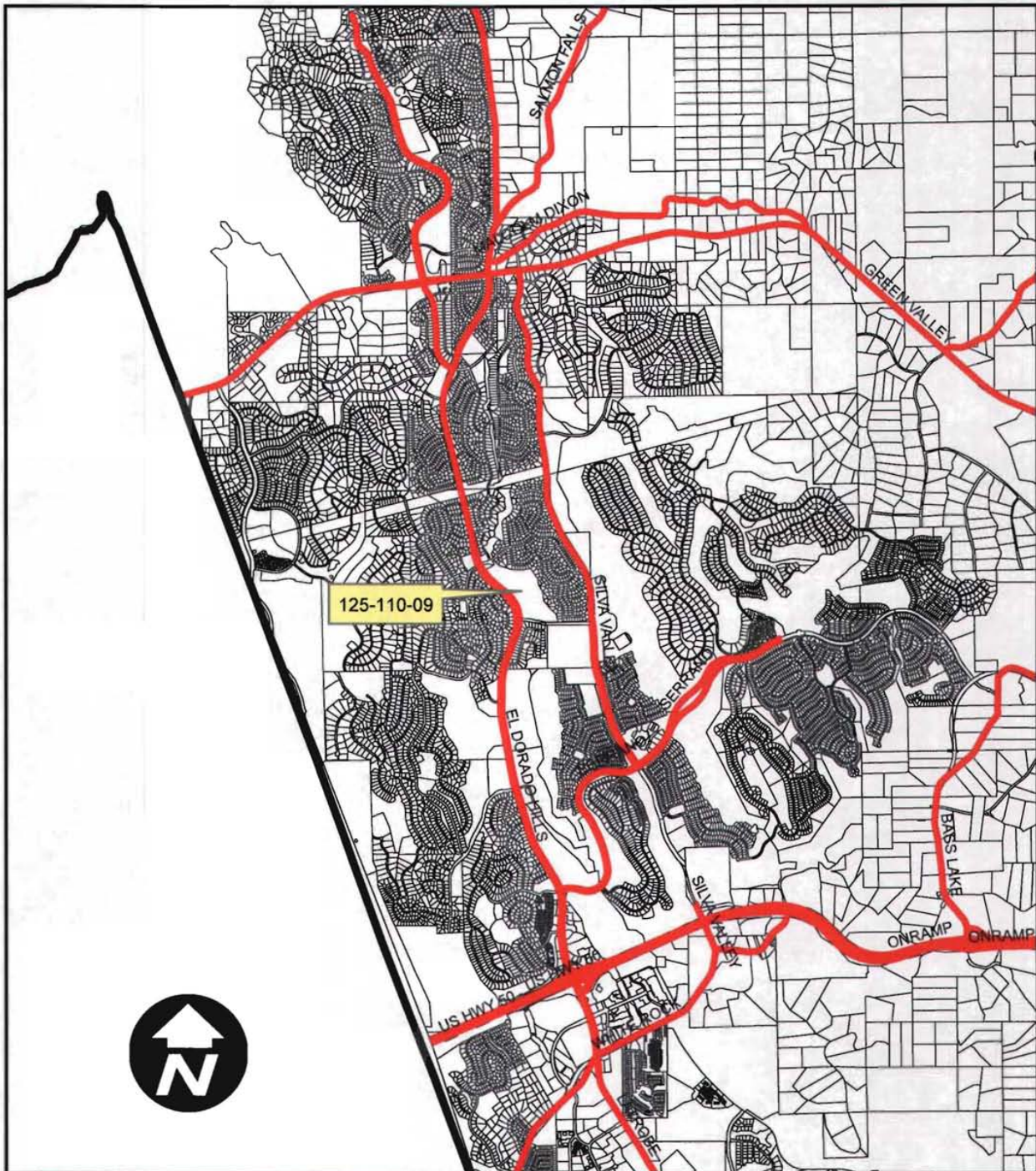





Exhibit A: Location Map



-  cnty_bnd
-  gpsroads selection
-  major_roads
-  prclbase

S03-0005-R-3/El Dorado Hills Dog Park
Prepared By Aaron Mount

POR. SECS. 26, 27, 34, & 35, T.10N., R.8E., M.D.M.

125:11

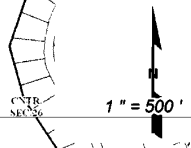

***Parcel Notes**

- ① - 0.690 A, NA
- ② - RS 13/96, 0.040 A, NA
- ③ - RS 17/138/2, 0.030 A
- ④ - RS 13/96, 0.050 A, NA
- ⑤ - 0.800 A
- ⑪ - 1.160 A, NA
- ⑫ - 0.280 A, NA

FOR MINERAL RIGHTS
SEE PG. 78



THIS MAP IS NOT A SURVEY. It is prepared by the El Dorado Co. Assessor's office for assessment purposes only. Area calculations and characteristics are not guaranteed. Users should verify items such as dimensions and acreage.

Acres are Estimates

Adjacent Map Pages Shown in Grey Text
Assessor's Block Numbers Shown in Ellipses
Assessor's Parcel Numbers Shown in Circles

Rev. Jan. 2, 2009

Assessor's Map Bk. 125, Pg. 11
County of El Dorado, CA

EXHIBIT B

Exhibit C: General Plan Land Use Map

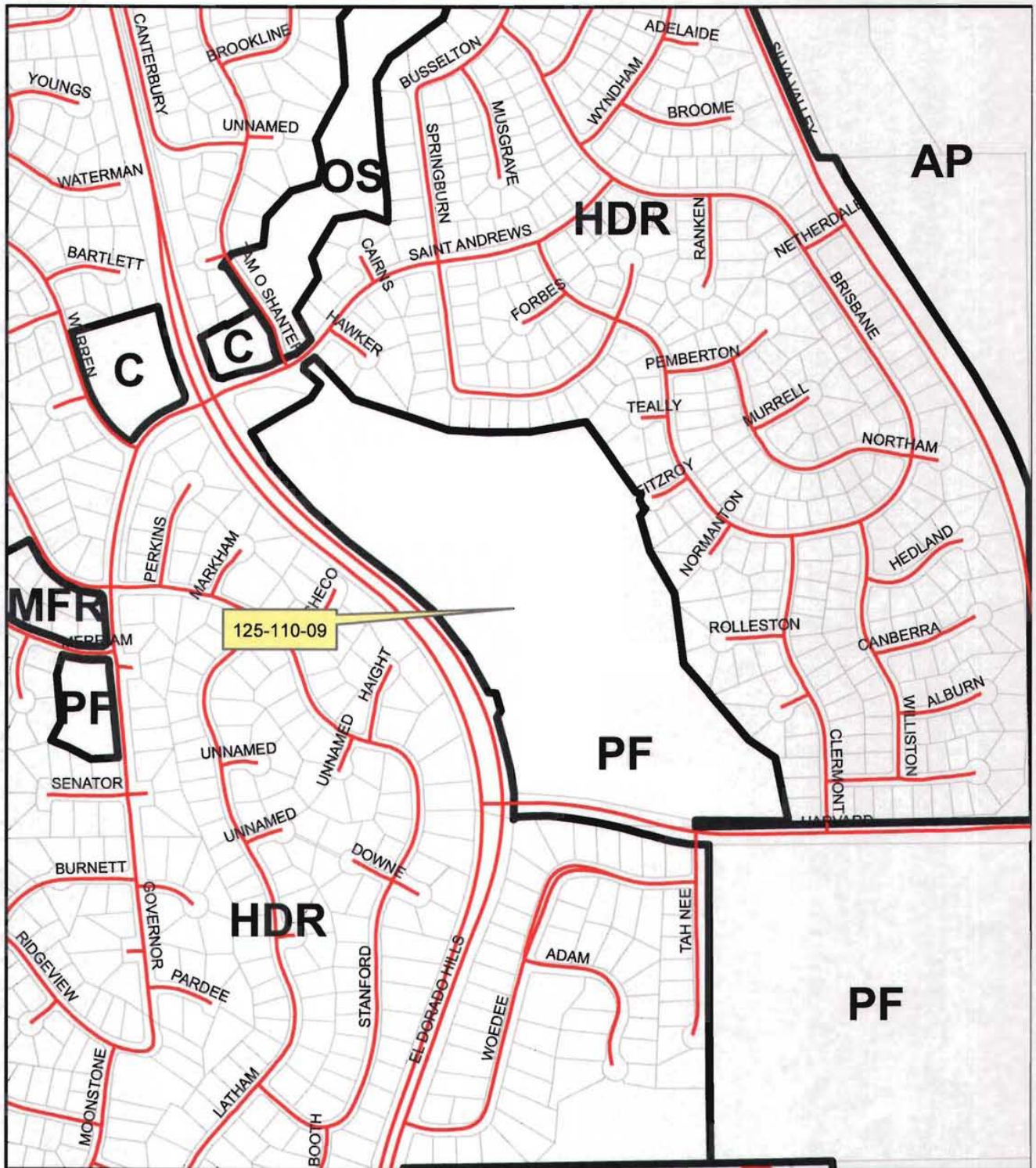

- gprroads
- ludesign
- prclbase selection
- prclbase



S03-0005-R-3/EI Dorado Hills Dog Park
Prepared By Aaron Mount

Exhibit D: Zone District Map

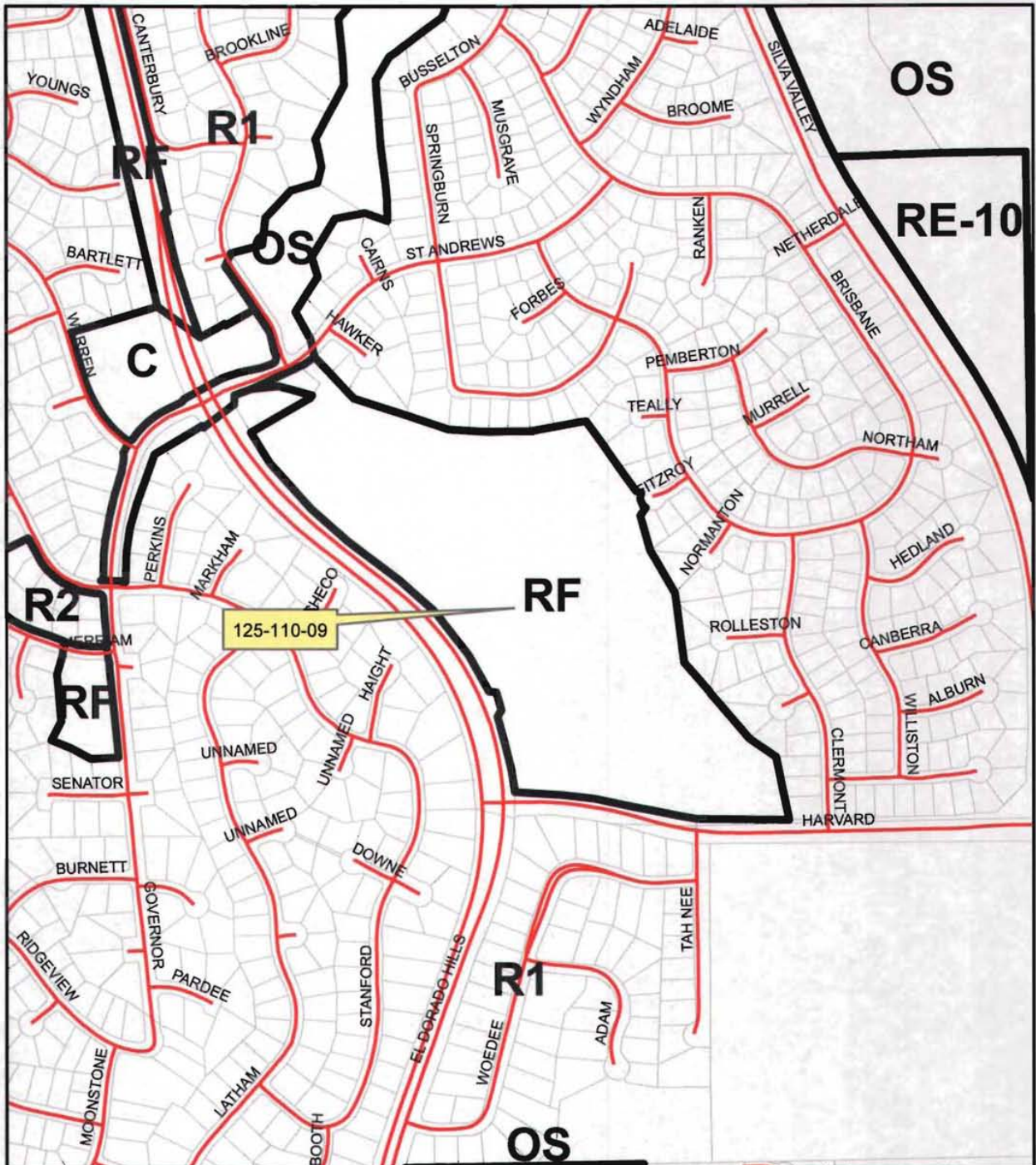

- gprroads
- zonedes
- prclbase selection
- prclbase



S03-0005-R-3/El Dorado Hills Dog Park
Prepared By Aaron Mount

Exhibit E: Site Plan

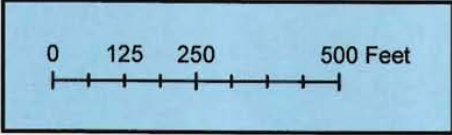
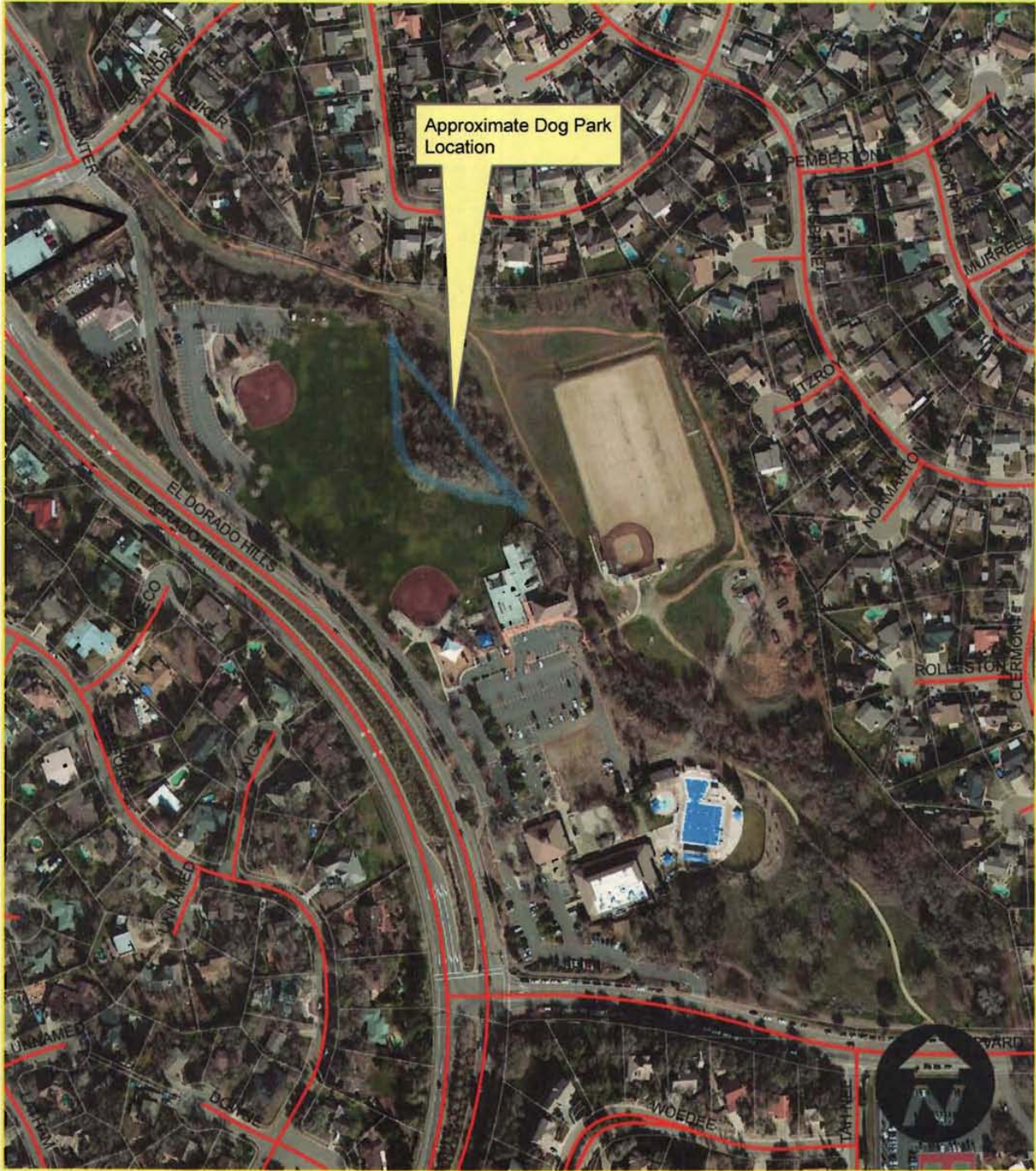

S03-0005-R-3
EDH Comm. Dog Park

EXHIBIT F

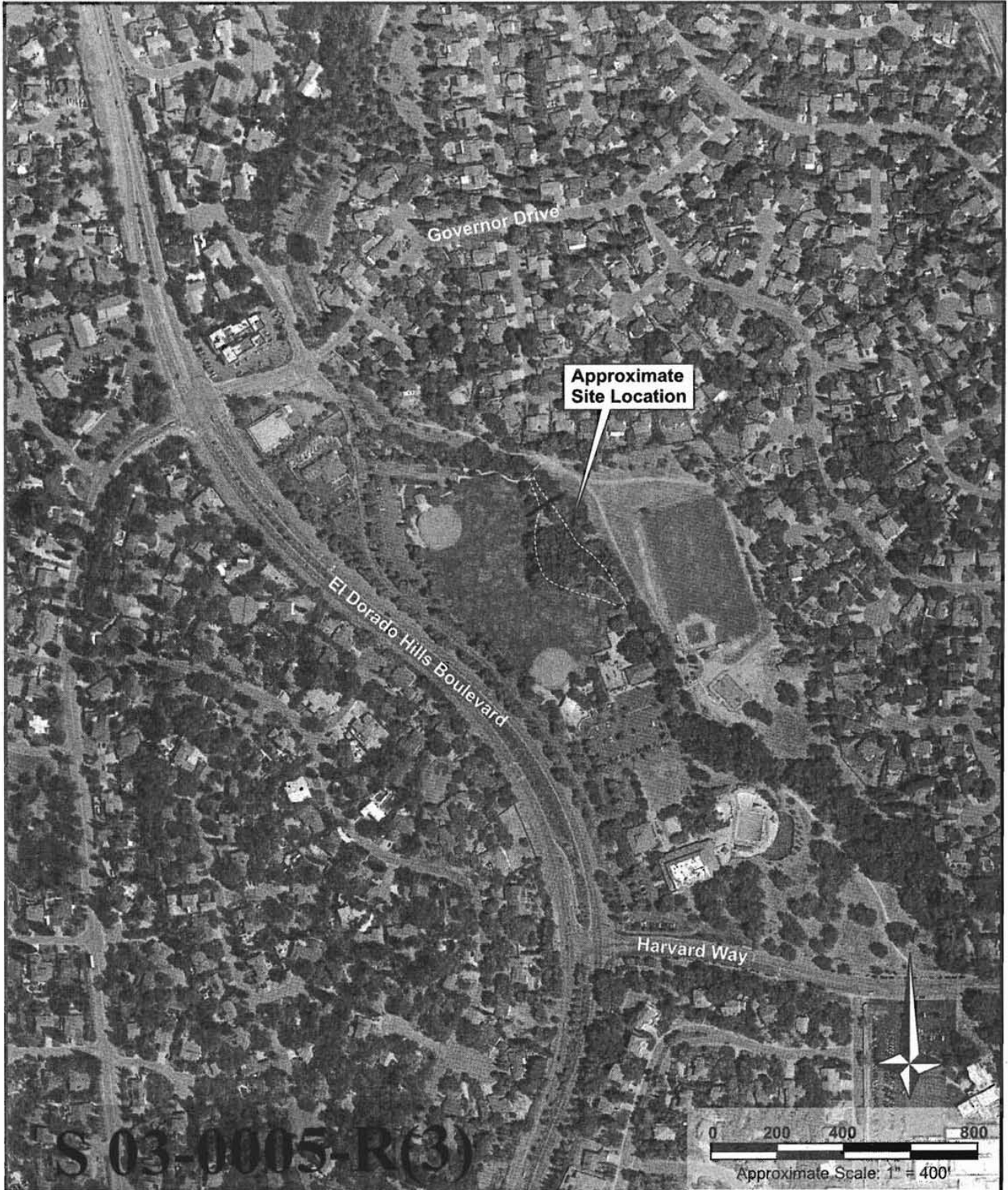

BASE MAP REFERENCE: Google Earth, Aerial Data Dated 8-13-2013

<p>YOUNGDAHL CONSULTING GROUP, INC. GEOTECHNICAL • ENVIRONMENTAL • MATERIALS TESTING</p>	<p>Project No.: E02261.021</p> <p>October 2013</p>	<p>VICINITY MAP El Dorado Hills Community Services District - New Dog Park El Dorado Hills, California</p>	<p>FIGURE A-1</p>
---	--	---	------------------------------

Proposed Dog Park

A Community Partnership Project

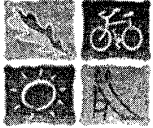

El Dorado Hills
COMMUNITY SERVICES DISTRICT

EDDOG
El Dorado Dog Owners Guild

A 2014 Capital Improvements Project for
Community Park

14 JAN -9 PM 2:53
RECEIVED
PLANNING DEPARTMENT

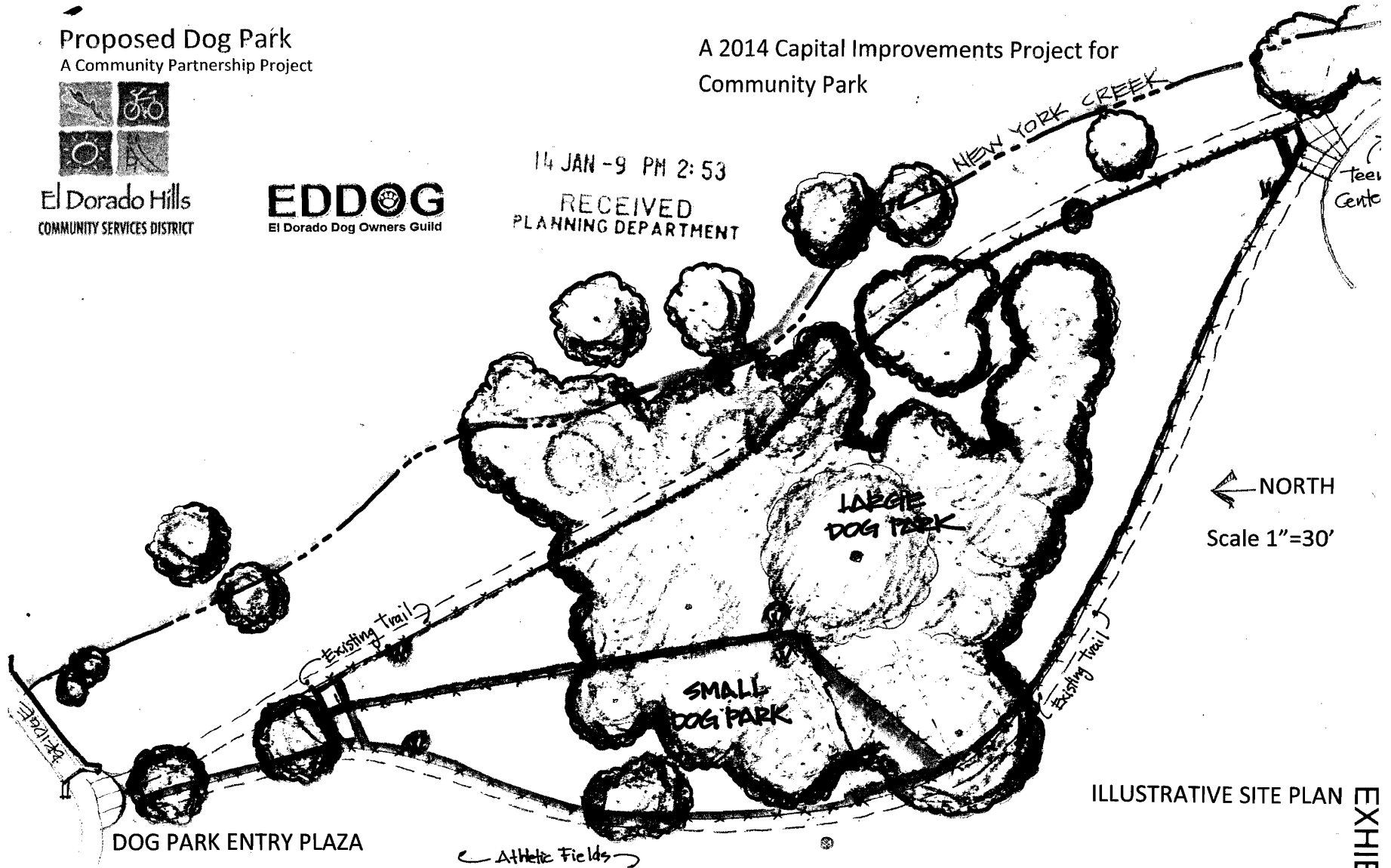

← NORTH
Scale 1"=30'

ILLUSTRATIVE SITE PLAN
EXHIBIT G

S 03-0005-R(3)

ILLUSTRATIVE SITE CROSS SECTION

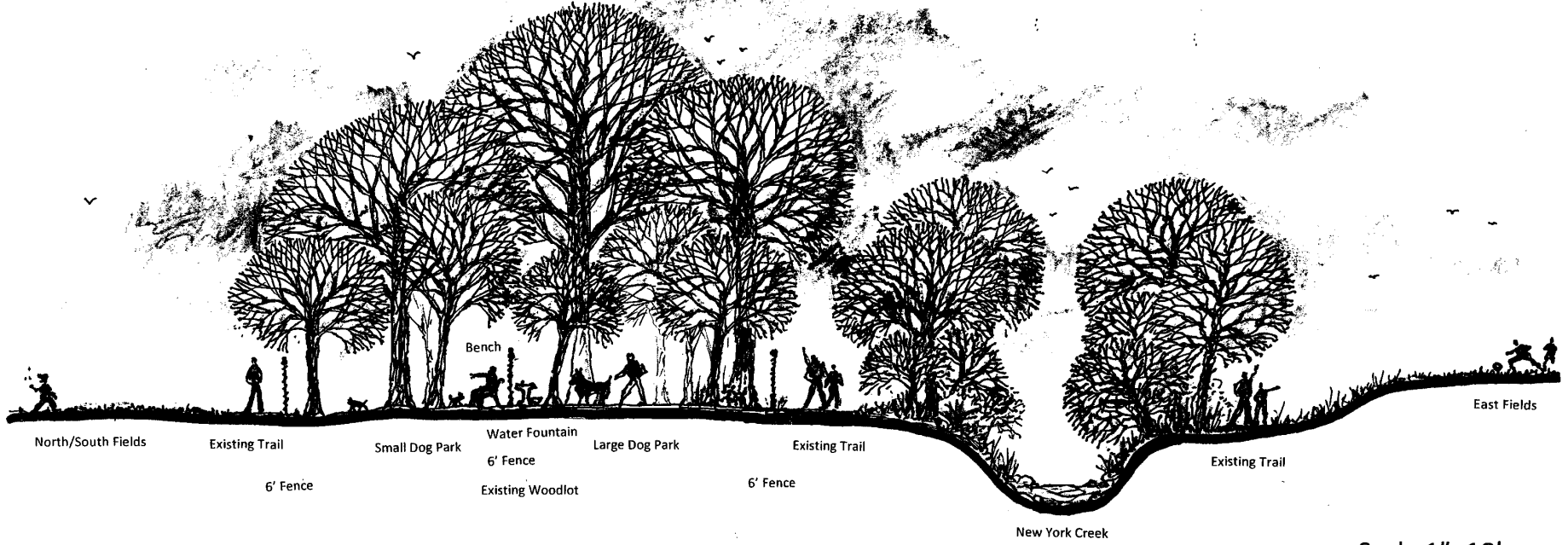

Scale 1"=10'

Proposed Dog Park
A Community Partnership Project

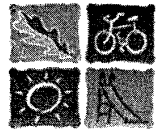

El Dorado Hills
COMMUNITY SERVICES DISTRICT

EDDOG
El Dorado Dog Owners Guild

A 2014 Capital Improvements Project for
Community Park

EXHIBIT H

Project Title:
El Dorado Hills Community Park Master Plan
Project Applicant:
El Dorado Hills Community Services District
Project Applicant Address:
1021 Harvard Way
El Dorado Hills, CA 95762
Date:
April 1, 2011

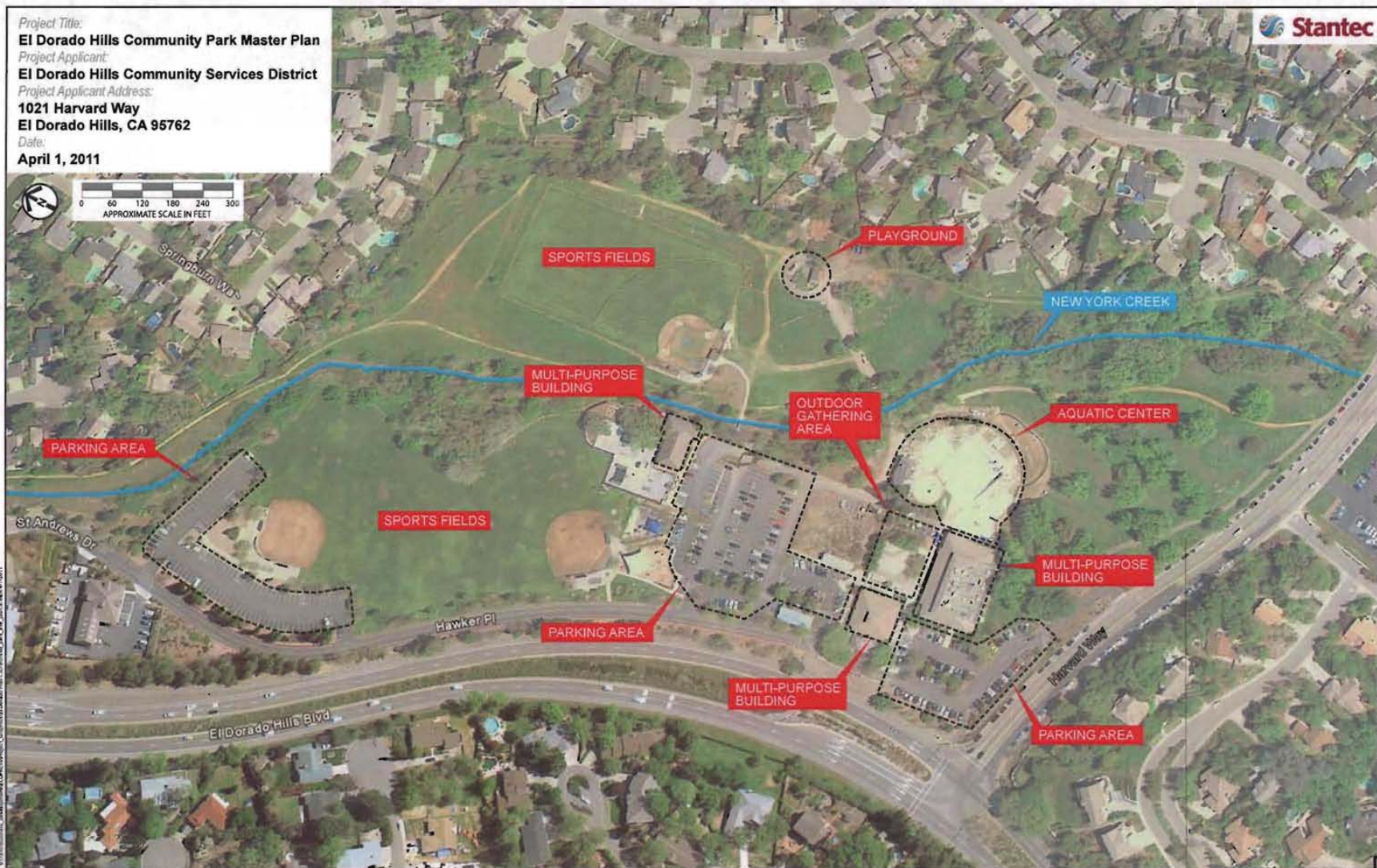
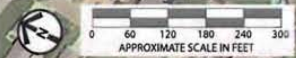

El Dorado Hills Community Park Site Plan

EXHIBIT I

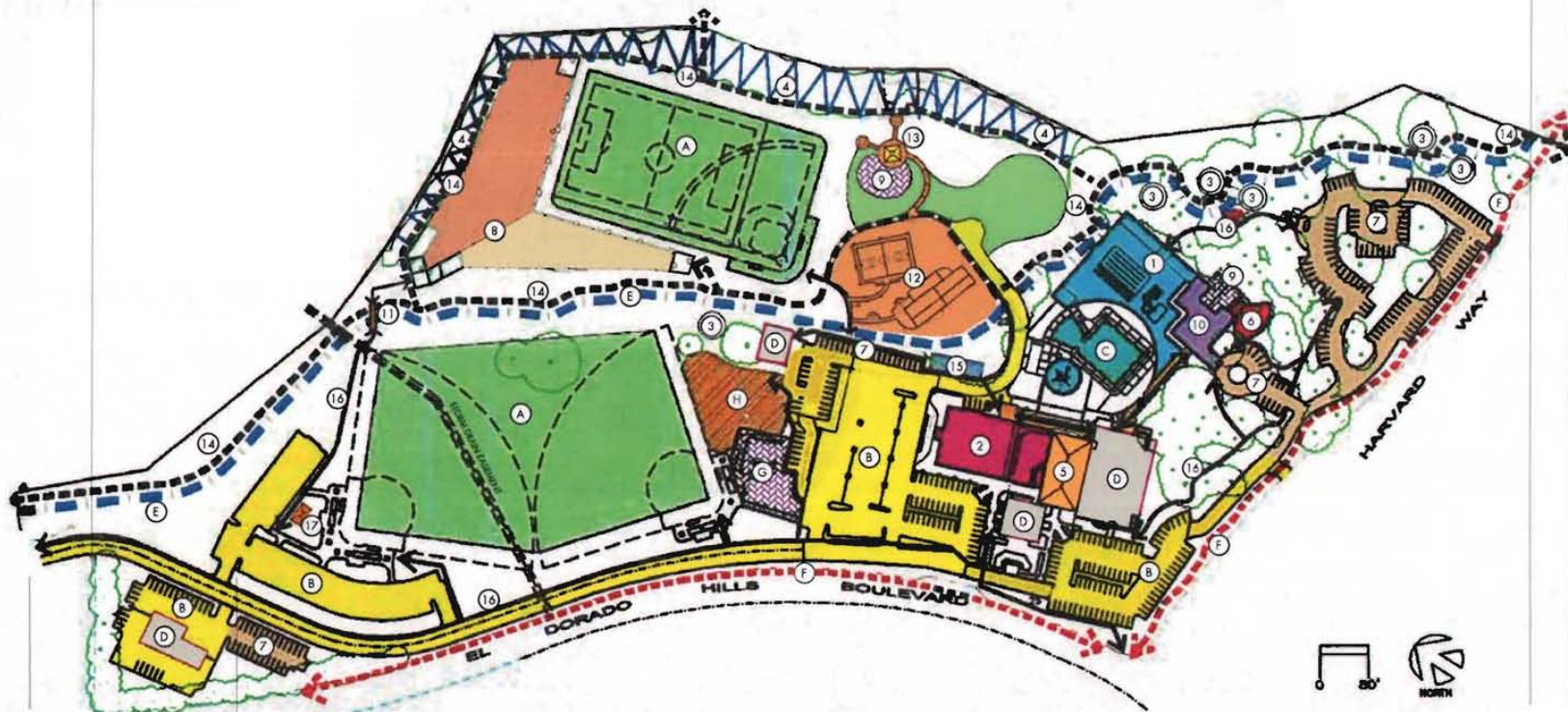

LEGEND

EXISTING FACILITIES

- A** - SPORTS FIELD/TURF
- B** - PARKING/DRIVEWAY/ROADWAY
- C** - POOLS
- D** - BUILDINGS
RENOVATE PAVILION BUILDING FOR MULTI-PURPOSE FUNCTIONS
- E** - CREEK
- F** - CLASS I BIKEWAY
- G** - PLAYGROUND
- H** - SKATE PARK

NEW (PROPOSED) FACILITIES

- 1** - AQUATIC CENTER
LOCKERS/RESTROOM BLDG.
ADMIN/TICKET/STORAGE
CONCESSIONS AREA
ACTIVITY POOL, SLIDE, TRAINING POOL
- 2** - COMMUNITY MULTIPURPOSE BLDG
+/- 12,000 SF MULTIPURPOSE ROOM (DIVIDABLE)
+/- 12,000 SF MEETING ROOMS STORAGE
ADMINISTRATIVE OFFICES, KITCHEN, ETC.
- 3** - SMALL PICNIC AREA
- 4** - PLANTED BUFFER [45' MINIMUM]
- 5** - COVERED OUTDOOR GATHERING
TEACHING RENTABLE SPACE
- 6** - OUTDOOR TEACHING
PERFORMANCE AREA
- 7** - NEW PARKING
- 8** - SMALL DOG/LARGE DOG PARKS
POTENTIAL ELEMENTS:
6' HIGH CHAIN LINK FENCING & DOUBLE GATES
NO LIGHTS, OPEN DOWN TO DUSK
SHADE CANOPIES AND SHADE TREES
DOG WASH, DRINKING FOUNTAIN,
POSSIBLE RECIRCULATING CREEK FEATURE
TRASH RECEPTACLES AND BENCHES
- 9** - PLAYGROUND
- 10** - DAY CAMP BLDG. (+/- 6000 SF) W/ CONNECTED
PLAYGROUND AND COVERED OUTDOOR MULTIPURPOSE
TEACHING/ACTIVITY AREA (+/- 4500 SF)
- 11** - PEDESTRIAN BRIDGE OVER CREEK
- 12** - GROUP PICNIC AREA WITH TURF, BASKETBALL COURT &
BATTING CAGES
- 13** - GROUP PICNIC SHELTER
- 14** - +/-10' WIDE MULTIPURPOSE TRAIL
- 15** - BOCCIE BALL/SHUFFLEBOARD PAVILION
- 16** - PEDESTRIAN WALKWAY
- 17** - 6 STALL RESTROOM

CONSENSUS PLAN

PROPOSED UPDATE (by Stantec)

EL DORADO HILLS COMMUNITY PARK MASTER PLAN UPDATE

EL DORADO HILLS COMMUNITY SERVICES DISTRICT

JANUARY 6, 2011



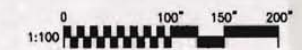
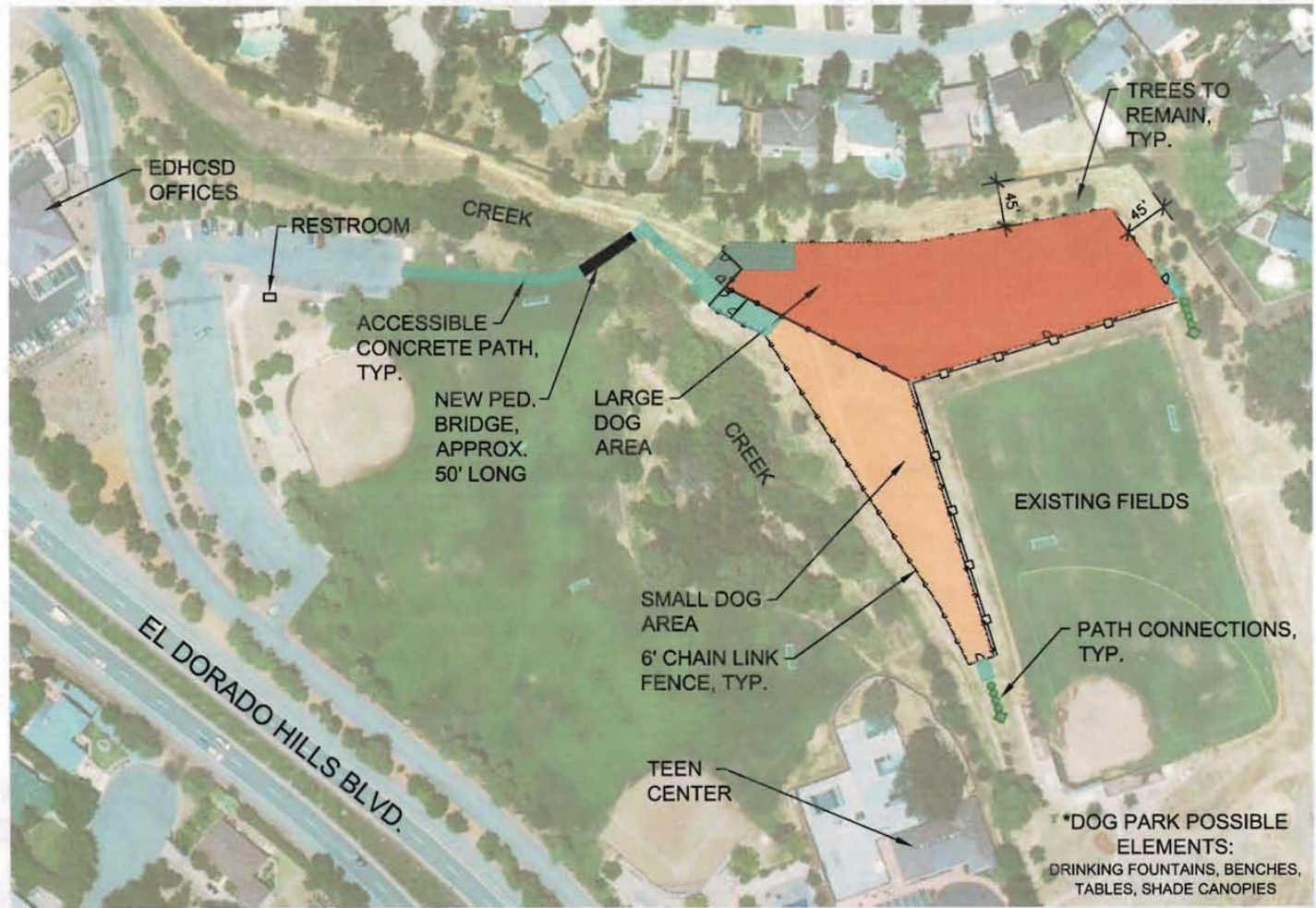

EXHIBIT K

Environmental Noise Assessment

El Dorado Hills Dog Park

El Dorado Hills, California (El Dorado County)

BAC Job #2013-081

Prepared For:

El Dorado Hills Community Services District

Mr. Brent Dennis
1021 Harvard Way
El Dorado Hills, CA 95762

Prepared By:

Bollard Acoustical Consultants, Inc.



Paul Bollard, President
INCE Board Certified Member

October 2, 2013

14 JAN -9 PM 2:51
RECEIVED
PLANNING DEPARTMENT



S 03-0005-R(3)

Introduction

The proposed El Dorado Hills Dog Park (project) site is located within the El Dorado Hills Community Park at the location shown on Figure 1. Figure 2 presents the project site plan. Due to the proximity of existing residences to the project site, Bollard Acoustical Consultants, Inc. (BAC) was retained to prepare this noise study.

The purposes of this study are to quantify existing ambient noise conditions at the nearest residences, to predict noise levels associated with typical dog park activities at those same residences, to assess the state of compliance of those noise levels with El Dorado County noise standards, and to recommend measures which could be employed to reduce the potential for annoyance at sensitive neighboring uses.

Background on Noise and Acoustical Terminology

Noise is often described as unwanted sound. Sound is defined as any pressure variation in air that the human ear can detect. If the pressure variations occur frequently enough (at least 20 times per second), they can be heard and hence are called sound. The number of pressure variations per second is called the frequency of sound, and is expressed as cycles per second, called Hertz (Hz).

Measuring sound directly in terms of pressure would require a very large and awkward range of numbers. To avoid this, the decibel scale was devised. The decibel scale uses the hearing threshold (20 micropascals of pressure), as a point of reference, defined as 0 dB. Other sound pressures are then compared to the reference pressure, and the logarithm is taken to keep the numbers in a practical range. The decibel scale allows a million-fold increase in pressure to be expressed as 120 dB. Another useful aspect of the decibel scale is that changes in decibel levels correspond closely to human perception of relative loudness. Figure 3 illustrates common noise levels associated with various sources.

The perceived loudness of sound is dependent upon many factors, including sound pressure level and frequency content. However, within the usual range of environmental noise levels, perception of loudness is relatively predictable, and can be approximated by weighing the frequency response of a sound level meter by means of the standardized A-weighting network. There is a strong correlation between A-weighted sound levels (expressed as dBA) and community response to noise. For this reason, the A-weighted sound level has become the standard tool of environmental noise assessment. All noise levels reported in this section are in terms of A-weighted levels.

Figure 1

El Dorado Hills Dog Park - El Dorado County, California
Project Area and Ambient Noise Measurement Location

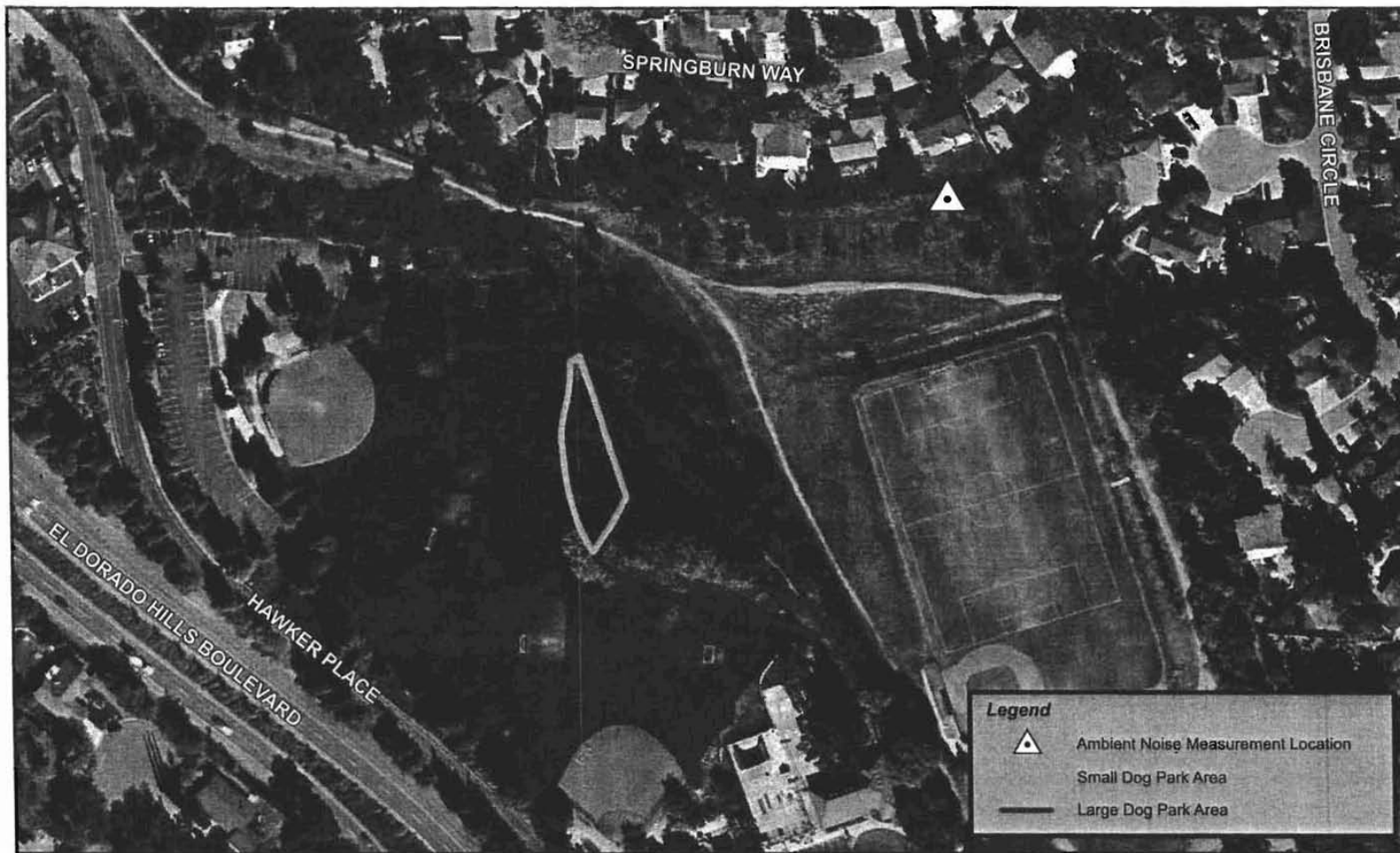

Figure 2
El Dorado Hills Dog Park - El Dorado County, California
Illustrative Site Plan

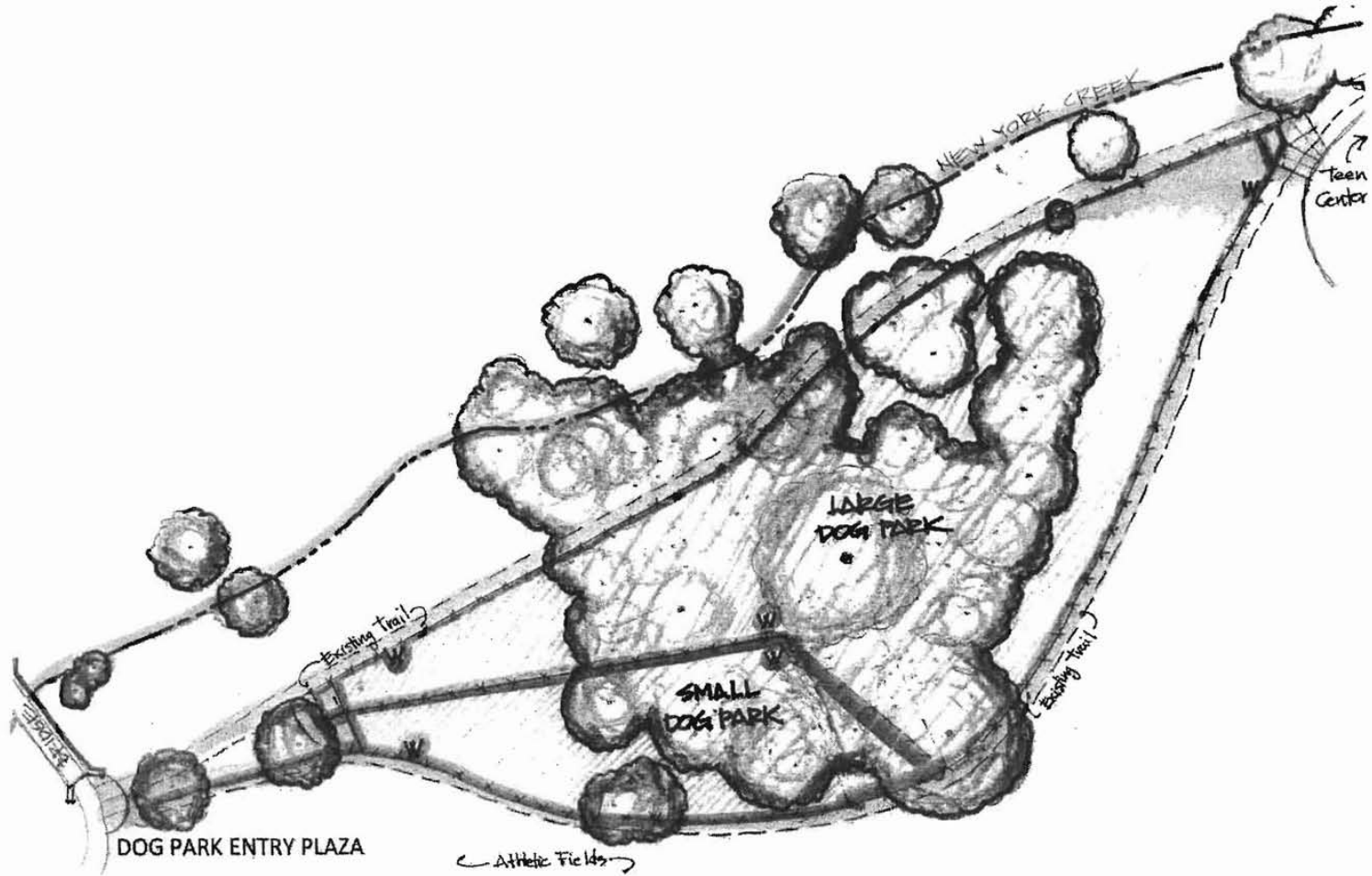

Figure 3
Typical A-Weighted Sound Levels of Common Noise Sources

Loudness Ratio Level	Sound Level (dBA)	Description
128	130	Threshold of pain
64	120	Jet aircraft take-off at 100 feet
32	110	Riveting machine at operators position
16	100	Shotgun at 200 feet
8	90	Bulldozer at 50 feet
4	80	Diesel locomotive at 300 feet
2	70	Commercial jet aircraft interior during flight
1	60	Normal conversation speech at 5-10 feet
1/2	50	Open office background level
1/4	40	Background level within a residence
1/8	30	Soft whisper at 2 feet
1/16	20	Interior of recording studio

Criteria for Acceptable Noise Exposure

El Dorado County General Plan Noise Element

The El Dorado County General Plan Noise Element establishes noise level criteria for acceptable noise exposure at residential uses due to non-transportation noise sources.

Table 1
Performance Standards for Non-Transportation Noise Sources
El Dorado County Noise Element

Noise Level Descriptor	Daytime (7am- 7pm)	Evening (7pm-10pm)	Nighttime (10pm-7am)
Hourly Leq (Average Level)	55 dB	50 dB	45 dB
Maximum Level	70 dB	60 dB	55 dB

Source: El Dorado County General Plan

Subjective Reaction to Changes in Noise Level Criteria

In cases where existing background noise levels already exceed local noise level standards, the significant criteria used in noise assessments typically judge a person's reaction to changes in noise levels due to a project. Table 2 is commonly used to show expected public reaction to changes in environmental noise levels. This table was developed on the basis of test subjects' reactions to changes in the levels of steady-state pure tones or broad-band noise and to changes in levels of a given noise source. It is probably most applicable to noise levels in the range of 50 to 70 dBA, which is the usual range of voice and interior noise levels.

Table 2
Subjective Reaction to Changes in Noise Levels of Similar Sources

Change in Level, dBA	Subjective Reaction	Change In Acoustical Energy
1	Imperceptible (Except for Tones)	1.3
3	Just Barely Perceptible	2.0
6	Clearly Noticeable	4.0
10	About Twice (or Half) as Loud	10.0

Source: Architectural Acoustics, M. David Egan, 1988.

Existing Ambient Noise Environment in the Project Vicinity

The noise environment in the immediate vicinity of the project site is defined primarily by traffic noise emanating from El Dorado Hills Boulevard and existing activities at the El Dorado Hills Community Park. To quantify background noise levels at the nearest existing residences to the project site, Bollard Acoustical Consultants, Inc. conducted a 24-hour continuous ambient noise level measurement survey at the location shown on Figure 1.

The continuous measurements were conducted over the weekend of May 21-22, 2011. The continuous measurement site was located adjacent to one of the nearest residential property lines to the project site. The noise monitoring results are summarized in Table 3. The complete noise monitoring results are provided in tabular and graphical form in Appendices B & C, respectively.

Table 3
Summary of Ambient Noise Level Measurements
El Dorado Hills Dog Park Project Site – May 21-22, 2011

Date	Daytime		Evening		Ldn
	Leq	Lmax	Leq	Lmax	
Saturday - May 21, 2011	49-56	59-77	50-52	69-72	53
Sunday – May 22, 2011	45-54	56-79	48-50	60-66	52

Note: The range of average and maximum noise levels are provided for daytime and evening hours only since the park would not be open at night.

Source: Bollard Acoustical Consultants

The noise measurement results shown in Table 3 indicate that the existing noise environment within the immediate project site vicinity is generally consistent with the County's exterior noise level standards shown in Table 1. More specifically, the highest measured weekend daytime average levels were 54-56 dB, which are consistent with the County's 55 dB Leq daytime standard. Similar conclusions hold for the measured average noise levels during evening periods. As a result, satisfaction of the County's average (Leq) standards would be sufficient to ensure that the project does not create a significant increase in ambient noise levels.

Evaluation of the measured maximum noise levels (Lmax), illustrated in Appendix C, indicates that existing maximum noise levels measured at the nearest residential property line to the project site frequently exceeded 70 dB during daytime hours. These elevated maximum noise levels were observed by BAC staff during the setup and retrieval of the noise monitoring system to be caused by dogs barking within the backyards of these nearest residences. As a result, the appropriate maximum noise level standard to be applied to this project would be the County's daytime 70 dB Lmax standard, during both daytime and evening hours.

Evaluation of Dog Park Noise Generation

Dogs barking outdoors are often considered potentially significant noise sources which could adversely affect nearby noise-sensitive land uses. To quantify noise levels associated with dog park activities, Bollard Acoustical Consultants, Inc. utilized BAC noise level data collected at three existing dog parks in the greater Sacramento area in recent years. Those three dog parks included the Marco Park, Granite Park, and Partner Park. In addition, barking dog noise level data collected at the All Pets Boarding facility in Loomis, California were used to supplement the dog park measurement data.

At Marco Dog Park, located in Roseville, California, there were approximately 10-12 dogs present during the measurement. There was minimal noise production from dogs that were present due to the large size of the park and because the dogs were fairly spread out during the measurement. During the fifteen-minute measurement, there was only one occurrence of barking observed.

Granite Park was observed to be the busiest of the three dog parks visited. The park is much larger in size than the other two parks and is considered representative of reasonable worst-case noise generation at the project site. The park amenities included a large open dirt playground, grassy play areas around the perimeter, and water hole gated off from the rest of the park. There were approximately 40-45 dogs present at park during the measurement. There were multiple instances of dogs barking as well as people shouting and clapping. Most dogs were playing amongst each other and not producing substantial noise. Only a few dogs in particular were barking and responsible for most of the noise generation. Measurements at this park were taken at three locations. The first measurement was taken in the center of the dog park where most of the activity was taking place. The second site was adjacent to the water hole area and the last site was placed in the parks north-east corner which provided a greater setback than the first two sites.

Partner Park, located in South Sacramento, was much smaller in overall size than the first two parks and the dog interaction/play area was more confined. There were approximately 12-15 dogs present during the measurement. The variation is attributable to people entering and exiting the park. The noise generating activities were similar to those that took place at the first two sites. There were only a few occurrences of barking during the measurement.

During the noise level measurements at the All Pets Boarding facility there were 39 dogs present. The dogs had to be provoked by honking a car horn near the kennel areas to get several of them to bark in unison. When the provocation stopped, the barking also stopped. At a distance of approximately 200 feet from the dogs, the maximum noise level generated by the barking dogs was approximately 55 dB L_{max} . Table 4 summarizes the results of the dog park noise measurements.

Table 4
Dog Park Noise Level Measurement Results

Location	Distance* (ft)	Measured Noise Level (dB)				Approximate Number of Dogs
		L ₅₀	L ₂₅	L ₅	L ₂	
Marco Dog Park (Roseville)	100	49	51	53	58	10-12
Granite Park (Sacramento)	25	53	57	64	69	40-45
	35	53	59	64	68	
	100	46	48	52	58	
Partner Park (S. Sacramento)	20	53	56	60	64	12-15

Note: * Approximate distance to center of activity.

Source: Bollard Acoustical Consultants, Inc.

The maximum noise levels measured at the three parks are not displayed in Table 3 because of difficulty in determining the distance to the dog responsible for creating the maximum level. The measurements represent the noise levels at an approximate reference distance to the center of dog activity. Therefore if a dog were to bark at a distance closer than the reference distance listed it could mislead the reader to believe that the barking only occurred at the listed reference distance, which could further lead to an over or understatement of potential impacts. For this reason the maximum noise level data from the All Pets Boarding facility was utilized in this analysis, as the data collected at that location was from a controlled and accurate distance. The maximum noise level measurement taken at the All Pets Boarding facility more accurately represents appropriate L_{max} since it was in a controlled environment.

Predicted El Dorado Hills Dog Park Noise Levels

From the data contained in Table 4 and that collected at All Pets Boarding, the reference average and maximum noise level at a representative distance of 100 feet was assumed for this project to be 50 dB Leq and 65 dB Lmax. These data were utilized to predict dog park activity noise levels at the nearest residential backyard areas to the north and east. A sound attenuation rate of 6 dB per doubling of distance was used as dog park activity noise represents an acoustical point source.

Figure 1 outlines the locations of the proposed dog park areas. That figure was used to scale the distances from the dog park areas to the nearest residential backyard areas. For the prediction of maximum noise levels, the distances between the dog park boundaries and

nearest residences were scaled. For the prediction of average noise levels, the distance between the approximate center of the dog park area and nearest residences were scaled. Because the park proposes both large dog and small dog areas, the distances were scaled separately.

Table 5
Predicted El Dorado Hills Dog Park Noise Levels at Nearest Residences

Location	Lmax Distance	Predicted Lmax	Leq Distance	Predicted Leq
Large Dog Area	200	59	350	39
Small Dog Area	200	59	290	41
Daytime Noise Standard	—	60	—	50
Evening Noise Standard	—	70	—	55

Source: Bollard Acoustical Consultants, Inc.

Analysis and Recommendations

The Table 5 data indicate that predicted noise associated with dog park activities would comply with the El Dorado County noise standards shown in Table 2 at the nearest neighbors during both daytime and evening hours. As a result, no further noise mitigation measures would be warranted for this project.

Conclusions

This analysis concludes that noise generated by the potential barking of dogs at the proposed dog park is predicted to satisfy the El Dorado County noise standards for exterior areas of noise-sensitive land uses. Therefore, no additional noise mitigation measures appear to be warranted for this project.

These conclusions are based on BAC Staff (Bollard) observations and reference noise level measurements of existing dog parks in the greater Sacramento area. Changes to anticipated dog park locations shown in Figure 1 could result in actual noise levels within the nearest residential backyard areas differing from those described herein. BAC Staff is not responsible for noise impacts resulting from such changes.

This concludes our environmental noise assessment for the proposed El Dorado Hills Dog Park in El Dorado County, California. Please contact me at (916) 663-0500 or paulb@bacnoise.com if you have any questions or require additional information.

Appendix A Acoustical Terminology

Acoustics	The science of sound.
Ambient Noise	The distinctive acoustical characteristics of a given space consisting of all noise sources audible at that location. In many cases, the term ambient is used to describe an existing or pre-project condition such as the setting in an environmental noise study.
Attenuation	The reduction of an acoustic signal.
A-Weighting	A frequency-response adjustment of a sound level meter that conditions the output signal to approximate human response.
Decibel or dB	Fundamental unit of sound, A Bell is defined as the logarithm of the ratio of the sound pressure squared over the reference pressure squared. A Decibel is one-tenth of a Bell.
CNEL	Community Noise Equivalent Level. Defined as the 24-hour average noise level with noise occurring during evening hours (7 - 10 p.m.) weighted by a factor of three and nighttime hours weighted by a factor of 10 prior to averaging.
Frequency	The measure of the rapidity of alterations of a periodic signal, expressed in cycles per second or hertz.
L_{dn}	Day/Night Average Sound Level. Similar to CNEL but with no evening weighting.
Leq	Equivalent or energy-averaged sound level.
L_{max}	The highest root-mean-square (RMS) sound level measured over a given period of time.
Loudness	A subjective term for the sensation of the magnitude of sound.
Masking	The amount (or the process) by which the threshold of audibility is for one sound is raised by the presence of another (masking) sound.
Noise	Unwanted sound.
Peak Noise	The level corresponding to the highest (not RMS) sound pressure measured over a given period of time. This term is often confused with the Maximum level, which is the highest RMS level.
RT₆₀	The time it takes reverberant sound to decay by 60 dB once the source has been removed.
Sabin	The unit of sound absorption. One square foot of material absorbing 100% of incident sound has an absorption of 1 sabin.
SEL	A rating, in decibels, of a discrete event, such as an aircraft flyover or train passby, that compresses the total sound energy of the event into a 1-s time period.
Threshold of Hearing	The lowest sound that can be perceived by the human auditory system, generally considered to be 0 dB for persons with perfect hearing.
Threshold of Pain	Approximately 120 dB above the threshold of hearing.

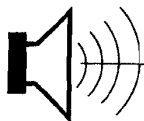

BOLLARD

Acoustical Consultants

Appendix B-1
 El Dorado Hills Dog Park
 24hr Continuous Noise Monitoring
 Saturday May 21, 2011

Hour	Leq	Lmax	L50	L90
0:00	44	55	42	37
1:00	41	56	39	34
2:00	39	53	37	32
3:00	37	51	33	30
4:00	37	50	34	29
5:00	46	65	43	37
6:00	46	72	43	39
7:00	49	72	46	43
8:00	55	77	49	46
9:00	54	74	49	46
10:00	52	74	49	46
11:00	52	71	49	46
12:00	50	59	49	46
13:00	51	66	49	46
14:00	52	74	49	45
15:00	51	71	48	45
16:00	50	66	48	45
17:00	56	70	49	46
18:00	51	74	50	47
19:00	52	72	50	47
20:00	50	67	49	45
21:00	50	69	48	45
22:00	48	56	47	44
23:00	49	72	45	41

	Statistical Summary					
	Daytime (7 a.m. - 10 p.m.)			Nighttime (10 p.m. - 7 a.m.)		
	High	Low	Average	High	Low	Average
Leq (Average)	56.2	48.5	52.1	48.9	36.9	44.7
Lmax (Maximum)	76.7	59.5	70.4	71.8	50.2	58.8
L50 (Median)	50.2	46.1	48.9	47.0	33.4	40.4
L90 (Background)	47.1	43.1	45.7	44.1	29.0	35.9

Computed Ldn, dB	53.3
% Daytime Energy	90%
% Nighttime Energy	10%



**Appendix B-2
 El Dorado Hills Dog Park
 24hr Continuous Noise Monitoring
 Sunday May 22, 2011**

Hour	Leq	Lmax	L50	L90
0:00	45	66	43	37
1:00	42	59	39	32
2:00	41	55	38	31
3:00	37	51	32	27
4:00	37	50	32	28
5:00	46	65	44	36
6:00	45	66	43	38
7:00	45	56	44	38
8:00	49	67	48	43
9:00	50	71	48	45
10:00	49	61	48	44
11:00	50	71	49	45
12:00	52	75	49	45
13:00	51	71	48	45
14:00	50	60	49	46
15:00	50	60	49	46
16:00	54	79	49	46
17:00	52	73	50	47
18:00	54	69	51	47
19:00	50	66	49	45
20:00	49	60	48	45
21:00	48	60	46	42
22:00	45	58	44	39
23:00	44	56	42	37

	Statistical Summary					
	Daytime (7 a.m. - 10 p.m.)			Nighttime (10 p.m. - 7 a.m.)		
	High	Low	Average	High	Low	Average
Leq (Average)	54.0	45.2	50.7	45.7	36.5	43.3
Lmax (Maximum)	78.6	55.8	66.5	66.5	50.1	58.6
L50 (Median)	51.3	43.8	48.4	44.0	31.9	39.6
L90 (Background)	46.9	38.0	44.7	39.2	27.3	34.0

Computed Ldn, dB	51.9
% Daytime Energy	90%
% Nighttime Energy	10%



**Appendix C-1
El Dorado Hills Dog Park
24hr Continuous Noise Monitoring
Saturday May 21, 2011**

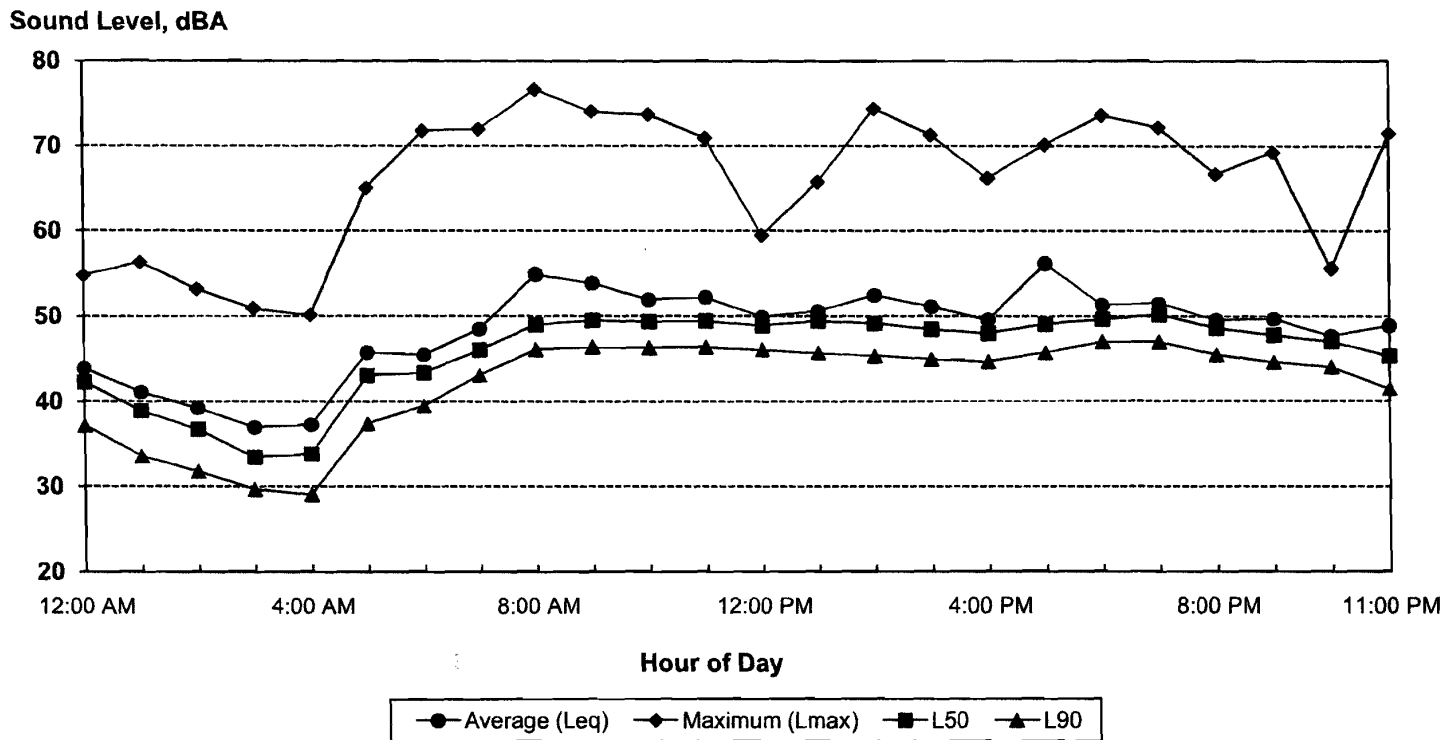

Ldn: 53 dB



**Appendix C-2
El Dorado Hills Dog Park
24hr Continuous Noise Monitoring
Sunday May 22, 2011**

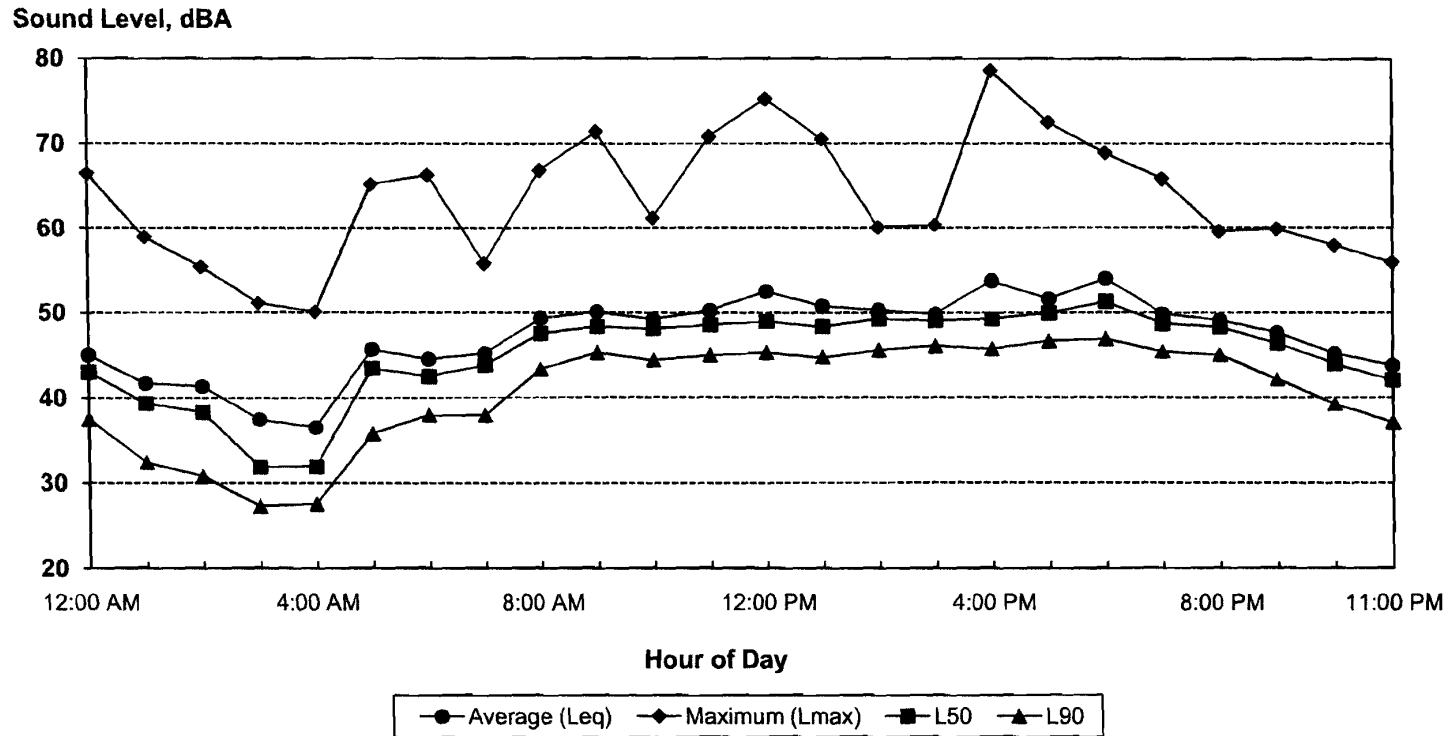

Ldn: 52 dB



EXHIBIT M

14 JAN -9 PM 2:55
RECEIVED
PLANNING DEPARTMENT

GEOTECHNICAL ENGINEERING STUDY
for
EL DORADO HILLS COMMUNITY SERVICE DISTRICT (CSD)
DOG PARK
Harvard Way & El Dorado Hills Drive
El Dorado Hills, California

Project No. E02261.021
November 2013



YOUNGDAHL
CONSULTING GROUP, INC.
GEOTECHNICAL • ENVIRONMENTAL • MATERIALS TESTING

FILE COPY

S 03-0005-R(3)



Project No. E02261.021
11 November 2013

El Dorado Hills Community Services District
1021 Harvard Way
El Dorado Hills, California 95762

Attn: Ms. Mindy Douglas

Subject: EL DORADO HILLS CSD DOG PARK
Harvard Way & El Dorado Hills Drive
El Dorado Hills, El Dorado County, California
GEOTECHNICAL ENGINEERING STUDY

- References:
1. El Dorado Hills Community Services District Dog Park, Assessment For Naturally Occurring Asbestos, prepared by Youngdahl Consulting Group, Inc., dated 23 July 2012.
 2. Proposal and Contract for El Dorado Hills Community Service District Dog Park, prepared by Youngdahl Consulting Group, Inc., dated 24 September 2013.

Dear Ms. Douglas:

In accordance with your authorization, Youngdahl Consulting Group, Inc. has performed a geotechnical engineering study for the proposed Dog Park located within the existing EDHCSD facility located on the north side of Harvard Way in El Dorado Hills, California. The purpose of this study was to explore and evaluate the surface and subsurface soil conditions at the Dog Park to develop geotechnical information and design criteria for the proposed project. Our scope was limited to a subsurface investigation, and preparation of this report per our proposal dated 24 September 2013 (reference 2).

Based upon our field study, subsurface exploration program and engineering analysis, we believe the primary geotechnical issue to be addressed are excavations into bedrock, drainage related to the shallow bedrock and presence of Naturally Occurring Asbestos (NOA). Due to the non-uniform nature of soils, other geotechnical issues may become more apparent during grading operations which are not listed above. The descriptions, findings, conclusions and recommendations provided in this report are formulated as a whole; specific conclusions or recommendations should not be derived or used out of context. Please review the limitations and uniformity of conditions section of this report.

This report has been prepared for the exclusive use of EDHCSD and their consultants, for specific application to this project, in accordance with generally accepted geotechnical engineering practice. Should you have any questions or require additional information, please contact our office at your convenience.

Very truly yours,
Youngdahl Consulting Group, Inc.

Martha A. McDonnell, P.E.
Associate Engineer



Distribution: (4) to Client

TABLE OF CONTENTS

1.0 INTRODUCTION.....1
Purpose and Scope.....1
Project Understanding.....1
Naturally Occurring Asbestos1

2.0 FINDINGS2
Surface Observations2
Subsurface Conditions2
Groundwater Conditions.....2
Laboratory Testing3
Soil Expansion Potential.....3
Geologic Conditions3
Seismicity.....3
Liquefaction, Slope Instability and Surface Rupture Potential.....4
Static and Earthquake Induced Slope Instability.....4
Naturally Occurring Asbestos4

3.0 DISCUSSION AND CONCLUSIONS.....4
General4

4.0 SITE GRADING AND EARTHWORK IMPROVEMENTS.....4
Site Preparation4
Excavation Characteristics5
Soil Moisture Considerations.....6
Compaction Equipment.....6
Engineered Fill Criteria.....7
Slope Configuration and Grading8
Underground Improvements.....8

5.0 DESIGN RECOMMENDATIONS.....9
Seismic Criteria9
Shallow Conventional Foundations9
Retaining Walls11
Slab-on-Grade Construction.....12
Drainage Considerations.....15

6.0 DESIGN REVIEW AND CONSTRUCTION MONITORING.....15
Construction Monitoring.....15
Low Impact Development Standards.....16
Post Construction Monitoring16

7.0 LIMITATIONS AND UNIFORMITY OF CONDITIONS16

CHECKLIST OF RECOMMENDED SERVICES18

APPENDIX A19
Field study.....20
Logs of Exploratory Pits (Figures A-3 through A-5).....23
Soil Classification Chart and Pit Log Legend (Figure A-6).....24

GEOTECHNICAL ENGINEERING STUDY
for
EL DORADO HILLS COMMUNITY SERVICE DISTRICT (CSD)
DOG PARK

1.0 INTRODUCTION

This report presents the results of our Geotechnical Engineering Study performed for the proposed Dog Park planned to be constructed within the El Dorado Hills Community Service District (CSD) Community Park, located east of El Dorado Hills Boulevard and north of Harvard Way, in El Dorado Hills, California. An annotated vicinity map is provided on Figure A-1 to identify the approximate project location.

Purpose and Scope

The purpose of this study was to explore and evaluate the surface and subsurface conditions at the site, to provide geotechnical information and design criteria, and to develop geotechnical recommendations for the proposed project. The scope of this study includes the following:

- A review of geotechnical and geologic data available to us at the time of our study;
- A field study consisting of a site reconnaissance, followed by an exploratory program to observe and characterize the subsurface conditions;
- Engineering assessment of the data and information obtained from our field study, and literature review;
- Development of geotechnical recommendations regarding earthwork construction including, site preparation and grading, excavation characteristics, soil moisture conditions, compaction equipment, engineered fill criteria, slope configuration and grading, underground improvements, and drainage;
- Development of geotechnical design criteria for seismic conditions, shallow foundations, and slabs on grade;
- Preparation of this report summarizing our findings, conclusions, and recommendations regarding the above described information.

Project Understanding

We understand that the District is proposing to construct a Dog Park within the existing El Dorado Hills Community Park. The park will be located on the west side of New York Creek within a wooded area between the new bridge crossing and the existing outdoor area of the teen center. The proposed park may contain shade canopies, a dog wash area, benches, a drinking fountain and possibly a recirculating feature within the channel.

Naturally Occurring Asbestos

Naturally Occurring Asbestos (NOA) has been identified as a potential health hazard in certain areas of El Dorado County. NOA has been found in association with ultramafic rocks such as serpentinite, with fault zones and with certain metamorphic belts in the Sierra Nevada foothills. NOA mitigation has been performed in some portions of the El Dorado Hills Community Park. The project site lies within an asbestos review area defined by the El Dorado County Air Quality Management District. The planned dog park is located on sheared metavolcanic rock associated with the West Bear Mountains Fault Zone. NOA has been found in El Dorado County within this shear zone from Latrobe to the south all the way north to Folsom Lake.

On 9 July 2012 Youngdahl Consulting Group, Inc. collected six samples were collected from shallow hand auger borings (one foot or less deep) for NOA analysis. Two of the six samples were reported to contain Tremolite Asbestos at trace levels (less than 0.25%).



According to the El Dorado County Air Quality Management District, all grading work will be required to follow an asbestos dust hazard mitigation plan. Additional recommendations regarding NOA mitigation are presented in the reference 1 report.

If studies or plans pertaining to the site exist and are not cited as a reference in this report, we should be afforded the opportunity to review and modify our conclusions and recommendations as necessary.

2.0 FINDINGS

The following section describes our findings regarding the site conditions that we observed during our site reconnaissance and subsequent subsurface exploration. In addition, this section also provides the results of our geologic review, and engineering assessment/analysis related to the project site.

Surface Observations

The project site is an irregularly shaped area located within the northeastern portion of the existing EDHCSD Community Park. The proposed Dog Park is bounded by an athletic field and pedestrian bridge to the north, New York Creek and a pedestrian trail to the east and athletic fields to the south and west. The site is undeveloped with the exception of an unimproved walking path to the east. The site is covered with a moderate growth of weeds, several oaks and other deciduous trees are present adjacent to the creek. The site is relatively flat, sloping gently to the southeast. Several small piles of landscape debris were observed in the south and southwest areas of the site and two soil/rock piles were also noted (See Figure A-2).

Subsurface Conditions

Our field study included a subsurface exploration program conducted on 22 October 2013. The exploration program included the excavation of 3 exploratory points under the direction of our representative at the approximate locations shown on Figure A-2, Appendix A. A description of the field exploration program is provided in Appendix A.

Subsurface conditions were relatively similar in the three test points excavated for this study. The surface soils consist of medium stiff sandy SILT with gravel to depths of from less than 1 to at least 2 1/2 feet below the existing ground surface. In test pits TP-2 and TP-3 these soils were underlain by metavolcanic BEDROCK. Bedrock was not encountered in TP-1 (drilled to 21/2 feet) due to limitations of the excavation equipment used for this study. Generally, the bedrock is slightly weathered, indurated and closely fractured.

A more detailed description of the subsurface conditions encountered during our subsurface exploration is presented graphically on the "Exploratory Test Pit Logs", Figures A-3 through A-5, Appendix A. These logs show a graphic interpretation of the subsurface profile, and the location and depths at which samples were collected.

Groundwater Conditions

Groundwater conditions were not observed at excavated test pit locations. Generally, subsurface water conditions vary in the foothill regions because of many factors such as, the proximity to bedrock, fractures in the bedrock, topographic elevations, and proximity to surface water. Some evidence of past repeated exposure to subsurface water may include black staining on fractures, clay deposits, and surface markings indicating previous seepage. Based on our experience in the area, at varying times of the year water may be perched on less weathered rock and/or present in the fractures and seems of the weathered rock found beneath the site.

Laboratory Testing

Due to the nature of the planned development, presence of shallow bedrock and previous testing in with the EDHCS Dog Park, laboratory testing was not considered necessary.

Soil Expansion Potential

The near surface soils encountered on site consisted of sandy SILT, however, the bedrock materials can contain a "rind" of expansive clay as the weathered bedrock surface. If present it has been our experience that these materials can be sufficiently blended such that expansive soil mitigation measures may not be required. We recommend that improvement areas be observed by a representative of our firm prior to placement of structural materials to verify that no concentrated pockets of expansive clays are present. A review of grading plans should be performed prior to mass grading operations to determine the extent of mitigation measures required.

Geologic Conditions

The subject site lies in the lower portion of the Sierra Nevada Foothills, formed by ancient subduction and related vulcanism, continental accretion and uplift during the Jurassic and Cretaceous ages (CDMG, 1984, OFR 84-50). The project site is located completely within the shear zone for the West Branch of the Bear Mountains Fault Zone. The melange-ophiolitic bedrock on the east side of the Bear Mountains Fault is the result of continental accretion along an ancient subduction zone, now represented by the fault. This melange-ophiolitic bedrock typically consists of a chaotic mixture of metasedimentary and volcanic units with lesser amounts of gabbroic and ultramafic crystalline intrusive rocks, shales, cherts and thin limestone lenses.

The geologic units on the west side of the fault consist of the Copper Hill Volcanics of Jurassic Age. This metavolcanic bedrock typically consists of mafic to andesitic pyroclastic rocks, lava, and pillow lava with subordinate felsic porphyritic and pyroclastic rocks. Locally it is common to find Salt Springs Slate intercalated with the Copper Hill Volcanics.

It is common for the Bear Mountains Shear Zone to contain discrete blocks of the rock units adjoining both sides of the fault. The shear zone also provided a conduit for fluids to hydrothermally alter the sheared rock and incorporates localized slivers of ultramafic rock partially altered to serpentinites. Multiple periods of hydrothermal fluids of varying chemistry are evidenced by the presence of talc-chlorite and talc-tremolite schist, quartz and chalcedony veins, chrysotile veins, and tremolite-actinolite asbestos veins. Many of these vein materials have weathered to white clays in the near surface soils.

The highly sheared nature of the fault zone provides abundant conduits for groundwater flow. Seasonal artesian spring conditions are typical of the El Dorado Hills area and may affect the site during wet winter years.

Seismicity

According to the Fault Activity Map of California and Adjacent Areas (Jennings, 2010) and the Peak Acceleration from Maximum Credible Earthquakes in California (CDMG, 2007), no active faults or Earthquake Fault Zones (Special Studies Zones) are located on the project site. Additionally, no evidence of recent or active faulting was observed during our field study. The nearest mapped faults to the site are related to the potentially-active Bear Mountains Fault Zone, which has traces located 1 mile west and 5 miles east of the project site, and the potentially-active Melones Fault zone located 12 miles east of the site. The nearest mapped active fault to the site is the Dunnigan Hills fault located about 37 miles to the west-northwest.

Based on our literature review of shear-wave velocity characteristics of geologic units in California (Wills and Silva; August 1998: Earthquake Spectra, Volume 14, No. 3) and subsurface interpretations, we recommend that the project site be classified as Site Class C in accordance with Table 1613.5.2 of the 2010 CBC.

Liquefaction, Slope Instability and Surface Rupture Potential

Liquefaction is the sudden loss of soil shear strength and sudden increase in porewater pressure caused by shear strains, as could result from an earthquake. Research has shown that saturated, loose to medium-dense sands with a silt content less than about 25 percent located within the top 40 feet are most susceptible to liquefaction and surface rupture/lateral spreading.

Due to the absence of a permanent elevated groundwater table, the relatively low seismicity of the area, the relatively shallow depth to bedrock, and the relatively dense nature of site materials, the potential for site liquefaction is considered negligible. For the above-mentioned reasons, mitigation for these potential hazards is typically not required for the project site.

Static and Earthquake Induced Slope Instability

The existing slopes on the project site were observed to have adequate vegetation on the slope face, appropriate drainage away from the slope face, and no apparent tension cracks or slump blocks in the slope face or at the head of the slope. No other indications of slope instability such as seeps or springs were observed. Additionally, due to the absence of permanently elevated groundwater table, the relatively low seismicity of the area, and the relatively shallow depth to rock, the potential for seismically induced slope instability is considered negligible. As such, we anticipate that the risk of slope instability for the existing slope orientations is negligible.

Naturally Occurring Asbestos

Asbestos is classified by the EPA as a known human carcinogen. Naturally occurring asbestos (NOA) has been identified as a potential health hazard. The California Geological Survey published a map in 2000 (Open File Report 2000-02) that qualitatively indicates the likelihood for NOA in western El Dorado County. The project site is identified as being in a NOA review zone based on the published map. Previous testing of samples collected indicates NOA is present at the site; two of the six samples collected were reported to contain Tremolite Asbestos at trace levels (less than 0.25%). According to the El Dorado County Air Quality Management District, all grading work will be required to follow an asbestos dust hazard mitigation plan. A complete description of the sampling procedures, test results and recommendations are contained in the Reference 1 report.

3.0 DISCUSSION AND CONCLUSIONS

General

Based upon the results of our field explorations, findings, and analysis described above, it is our opinion that construction of the proposed improvements are feasible from a geotechnical standpoint, provided the recommendations contained in this report are incorporated into the design plans and implemented during construction. The native soils and rock recompacted as recommended below may be considered "engineered" and suitable for support of the planned improvements.

4.0 SITE GRADING AND EARTHWORK IMPROVEMENTS

Site Preparation

Preparation of the project site should involve site drainage controls, dust control, clearing and stripping, and exposed grade compaction considerations. The following paragraphs state our geotechnical comments and recommendations concerning site preparation.

Site Drainage Controls: We recommend that initial site preparation involve intercepting and diverting any potential sources of surface or near-surface water within the construction zones. Because the selection of an appropriate drainage system will depend on the water quantity, season, weather conditions, construction sequence, and methods used by the contractor, final decisions regarding drainage systems are best made in the field at the time of construction. All drainage and/or water diversion performed for the site should be in accordance with the Clean Water Act and applicable Storm Water Pollution Prevention Plan.

Dust Control: Dust control provisions should be provided for as required by the local jurisdiction's grading ordinance (i.e. water truck or other adequate water supply during grading). Special attention to dust control may be necessary due to the anticipated cuts into naturally occurring asbestos materials. Refer to the fugitive dust mitigation plan for details on grading within naturally occurring asbestos areas. Refer to Reference 1 for more discussion regarding dust control and the fugitive dust mitigation plan.

Clearing and Stripping: Clearing and stripping operations should include the removal of all organic laden materials including trees, bushes, root balls, root systems, and any soft or loose soil generated by the removal operations. Surface grass stripping operations are necessary based upon our observations during our site visit. Short or mowed dry grasses may be pulverized and lost within fill materials provided no concentrated pockets of organics result. It is the responsibility of the grading contractor to remove excess organics from the fill materials. **No more than 2 percent of organic material, by weight, should be allowed within the fill materials at any given location.**

General site clearing should also include removal of any loose or saturated materials within the proposed structural improvement and pavement areas. A representative of our firm should be present during site clearing operations to identify the location and depth of potential fills not disclosed by this report, to observe removal of deleterious materials, and to identify any existing site conditions which may require mitigation or further recommendations prior to site development. Preserved trees may require tree root protection which should be addressed on an individual basis by a qualified arborist.

Exposed Grade Compaction: Exposed soil grades following initial site preparation activities and overexcavation operations should be scarified to a minimum depth of 8 inches and compacted to the requirements for engineered fill. Prior to placing fill, the exposed subgrades should be in a firm and unyielding state. Any localized zones of soft or pumping soils observed within a subgrade should either be scarified and recompacted or be overexcavated and replaced with engineered fill as detailed in the engineered fill section below.

Excavation Characteristics

The exploratory test borings/pits were excavated using motorized auger equipped with an 8-inch bit. The degree of difficulty encountered in excavating our test borings/pits is an indication of the effort that will be required for excavation during construction. Based on our exploration points, we expect that the site soils can be excavated using conventional earthmoving equipment such as a Caterpillar D6 to D8 for grading and rubber tired backhoe for trench excavations not extending to the underlying bedrock materials.

The underlying bedrock materials can likely be excavated to depths of several feet using dozers equipped with rippers. We expect that the upper, weathered portion of the rock, indicated to extend up to approximately 3 feet below the rock surface at most locations, will require use of a Caterpillar D9 equipped with a single or multiple shank rippers, or similar equipment. We

anticipate that a ripper equipped D9 can penetrate at least as deep as our test pits at most locations with moderate effort. Blasting cannot be ruled out in areas of resistant rock.

Where hard rock cuts in fractured rock are proposed, the orientation and direction of ripping will likely play a large role in the rippability of the material. When hard rock is encountered, we should be contacted to provide additional recommendations prior to performing an alternative such as blasting.

Utility trenches will likely encounter hard rock excavation conditions especially in deeper cut areas. Utility contractors should be prepared to use special rock trenching equipment such as large excavators (Komatsu PC400 or CAT 345 or equivalent). Blasting to achieve utility line grades, especially in planned cut areas, cannot be precluded. Water inflow into any excavation approaching the hard rock surface is likely to be experienced in all but the driest summer and fall months. Pre-ripping during mass grading may be beneficial and should be considered with the Geotechnical Engineer prior to, or during mass grading.

Soil Moisture Considerations

The near-surface soils may become partially or completely saturated during the rainy season. Grading operations during this time period may be difficult since compaction efforts may be hampered by saturated materials. Therefore, we suggest that consideration be given to the seasonal limitations and costs of winter grading operations on the site. Special attention should be given regarding the drainage of the project site.

If the project is expected to work through the wet season, the contractor should install appropriate temporary drainage systems at the construction site and should minimize traffic over exposed subgrades due to the moisture-sensitive nature of the on-site soils. During wet weather operations, the soil should be graded to drain and should be sealed by rubber tire rolling to minimize water infiltration.

Compaction Equipment

In areas to receive structural soil fill, we anticipate that a large vibratory padded drum compactor or approved equivalent will be capable of achieving the compaction requirements for engineered fill provided the soil is placed and compacted within 0 to 3 percent over the optimum moisture content as determined by the ASTM D1557 test method and in lifts not greater than 12 inches in uncompacted thickness. The use of handheld equipment such as jumping jack or plate vibration compactors may require thinner lifts of 6 inches or less to achieve the desired relative compaction parameters.

Rock or Method Specification: In areas to receive structural fill with rock quantities greater than 30 percent by mass, a Caterpillar 825 steel-wheel compactor or approved equivalent should be employed as a minimum to facilitate breakdown of oversize bedrock materials and generation of soil fines during the fill placement process. If the quantity of rock fragments in the fills preclude traditional compaction testing, then the proposed fills should be compacted using method specifications as indicated below.

Due to the significant quantity of rock materials that will comprise a majority of the fills on the project site, a Caterpillar 825 steel-wheel compactor or approved equivalent should be employed as a minimum to facilitate breakdown of oversize bedrock materials and generation of soil fines during the fill placement process. If the quantity of rock fragments in the fills preclude traditional compaction testing, then the proposed fills should be compacted using method specifications as indicated in the Engineered Fill Criteria section below.

In focused or isolated areas where significant rock quantities will not be present, we anticipate that a large vibratory padded drum compactor or approved equivalent will be capable of achieving the compaction requirements for engineered fill provided the soil is placed and compacted within 0 to 3 percent over the optimum moisture content as determined by the ASTM D1557 test method and in lifts not greater than 12 inches in uncompacted thickness. The use of handheld equipment such as jumping jack or plate vibration compactors may require thinner lifts of 6 inches or less to achieve the desired relative compaction parameters.

Engineered Fill Criteria

All materials placed as fills on the site should be placed as "Engineered Fill" which is observed, tested, and compacted as described in the following paragraphs.

Suitability of Onsite Materials: We anticipate that a large amount of onsite soils will be generated during mass grading operations. We expect that soil generated from excavations on the site, excluding deleterious material, may be used as engineered fill provided the material does not exceed the maximum size specifications listed below

Rock fragments or boulders exceeding 24 inches in maximum dimension should not be placed within the upper five feet of site grades or utility corridors. The upper two feet of the site grades and within the zone of proposed underground facilities should consist of predominantly rocks and rock fragments less than 12 inches in maximum dimension. Boulders over 24 inches in maximum dimension should be placed within the deeper portions of fill embankments below a depth of 5 feet and a minimum of 5 feet from the finish slope face. The individual boulders should be spaced such that compaction of finer rock and soil materials between the boulders can be achieved with the equipment being used for compaction. Materials placed between the boulders should consist of predominantly soil and rock less than 12 inches in maximum dimension. The soil/rock mixture should be thoroughly mixed and placed between the boulders so as to preclude nesting or the formation of voids. Should insufficient deep fill areas exist for oversize rock disposal, the contractor should either dispose of the excess materials to an offsite location or mechanically reduce the rocks to less than 12 inches.

Import Materials: If imported fill material is needed for this project, import material should be approved by our firm prior to transporting it to the project. It is preferable that import material meet the following requirements:

1. Plasticity index not to exceed 12;
2. An angle of friction equal to or greater than 32°;
3. Should not contain rocks larger than 6 inches in diameter;
4. Not more than 15 percent passing through the No. 200 sieve.

If these requirements are not met, additional testing and evaluation may be necessary to determine the appropriate design parameters for foundations and other improvements.

Fill Placement and Compaction: All areas proposed to receive fill should be scarified to a minimum depth of 8 inches, moisture conditioned as necessary, and compacted to at least 90 percent of the maximum dry density based on the ASTM D1557 test method. The fill should be placed in thin horizontal lifts not to exceed 12 inches in uncompacted thickness. The fill should be moisture conditioned as necessary and compacted to a relative compaction of not less than 90 percent based on the ASTM D1557 test method. The upper 8 inches of fills placed under proposed pavement areas should be compacted to a relative compaction of not less than 95 percent based on the ASTM D1557 test method. Expansive clays, if encountered, should be mixed thoroughly with less expansive on site materials (silts, sands, and gravels) and should not be present in concentration within 5 feet of the building envelope, either vertically or laterally.

Proper disposition of clays on site should be verified by a representative of Youngdahl Consulting Group, Inc.

Fill soil compaction should be verified by means of in-place density tests performed during fill placement so that adequacy of soil compaction efforts may be evaluated as earthwork progresses, or by method specification if the quantity of rock fragments in the fills preclude traditional compaction testing. This will likely include the excavation of test pits within the fill materials to observe and document that a uniform over-optimum moisture condition, and absence of large and/or concentrated voids has been achieved prior to additional fill placement.

Method Specification: Soils exceeding 30 percent rock by mass may be considered non-testable by conventional methods. The materials may be placed as engineered fill if placed in accordance with the following method specification during full time observation by a representative of our firm.

Soils should be moisture conditioned and compacted in place by a minimum of four completely covering passes with a Caterpillar 825, or approved equivalent. The compactor's last two passes should be at 90 degrees to the initial passes. In areas where 95 percent relative compaction is designated, an additional two passes should be applied in each direction, with three completely covering passes made at 90 degrees to the initial three passes. Engineered fill should be constructed in lifts not exceeding 12 inches in uncompacted thickness, moisture conditioned and compacted in accordance with the above specification. Additional passes as deemed necessary during fill placement to achieve the desired condition based upon field conditions may be recommended.

Slope Configuration and Grading

The project site is proposed to have cuts and fill with a maximum slope orientation of 2H:1V (Horizontal:Vertical). Generally a cut slope orientation of 2H:1V is considered stable with the material types encountered on the site. A fill slope constructed at the same orientation is considered stable if compacted to the engineered fill recommendations as stated in the recommendations section of this report. All slopes should have appropriate drainage and vegetation measures to minimize erosion of slope soils.

Surficial stability of steeper cut slopes may be achievable due to the geology of the cut materials. Steepening of slopes greater than 2H:1V will require design and observation during the proposed cut. Any slope excavations proposed to be greater than 10 feet in maximum height should be evaluated during and prior to completion of site grading.

Underground Improvements

Trench Excavation: Trenches or excavations in soil should be shored or sloped back in accordance with current OSHA regulations prior to persons entering them. Where clay rind in combination with moist conditions is encountered in fractured bedrock, the project engineering geologist should be consulted for appropriate mitigation measures. The potential use of a shield to protect workers cannot be precluded. Refer to the Excavation Characteristics section of Site Grading and Improvements of this report for anticipated excavation conditions.

Backfill Materials and Compaction: Backfill materials for utilities should conform to the local jurisdiction's requirements. All backfill, placed after the underground facilities have been installed should be compacted a minimum of 90 percent relative compaction. Compaction should be accomplished using lifts which do not exceed 12 inches. However, thickness of the lifts should be determined by the contractor. If the contractor can achieve the required compaction using thicker lifts, the method may be judged acceptable based on field verification

by a representative of our firm using standard density testing procedures. Lightweight compaction equipment may require thinner lifts to achieve the required densities.

5.0 DESIGN RECOMMENDATIONS

Seismic Criteria

Based on the 2010 California Building Code, Chapter 16, and our site investigation findings, the following seismic parameters are recommended from a geotechnical perspective for structural design. The final choice of design parameters, however, remains the purview of the project structural engineer.

Seismic Design Parameters

Code Reference	Parameter	Value
Table No. 1613.5.2	Site Class	C
Figure No. 1613.5(3)*	Short-Period MCE at 0.2s, S_S	0.38g
Figure No. 1613.5(4)*	1.0s Period MCE, S_1	0.19g
Table No. 1613.5.3(1)**	Site Coefficient, F_a	1.20
Table No. 1613.5.3(2)**	Site Coefficient, F_v	1.61
Equation 16-36	Adjusted MCE Spectral Response Parameters, $S_{MS} = F_a S_S$	0.46
Equation 16-37	Adjusted MCE Spectral Response Parameters, $S_{M1} = F_v S_1$	0.31
Equation 16-38	Design Spectral Acceleration Parameters, $S_{DS} = \frac{2}{3} S_{MS}$	0.31
Equation 16-39	Design Spectral Acceleration Parameters, $S_{D1} = \frac{2}{3} S_{M1}$	0.21
Table 1613.5.6(1)	Seismic Design Category (Short Period), Occupancy I to III	B
Table 1613.5.6(1)	Seismic Design Category (Short Period), Occupancy IV	B
Table 1613.5.6(2)	Seismic Design Category (1-Second Period), Occupancy I to III	C
Table 1613.5.6(2)	Seismic Design Category (1-Second Period), Occupancy IV	D

* Values from Figures 1613.5(3)/(4) are derived from the National Earthquake Hazards Reduction Program (NEHRP) for Site Class B soil profiles.

** Values from Tables 1613.3(1)/(2) are adjustments to account for the Site Class (Project Specific) provided in Table 1613.5.2.

Shallow Conventional Foundations

We offer the following comments and recommendations for purposes of design and construction of shallow continuous and/or isolate pad foundations. The provided minimums do not constitute a structural design of foundations which should be performed by the structural engineer. Our firm should be afforded the opportunity to review the project grading and foundation plans to confirm the applicability of the recommendations provided below. Modifications to these recommendations may be made at the time of our review. In addition to the provided recommendations, foundation design and construction should conform to applicable sections of the 2010 California Building Code.

Bearing Capacities: An allowable dead plus live load bearing pressure of 2,000 psf may be used for design of conventional shallow foundations based on firm native soils or engineered fills and

4,000 psf for foundation based on weathered bedrock. The allowable pressures are for support of dead plus live loads and may be increased by 1/3 for short-term wind and seismic loads. The bearing capacities and bearing capacity equation were derived from the bearing capacity methods developed by Meyerhof (1963) and include a factor of safety of 3 into the values provided.

Foundation Settlement: A total settlement of less than 1 inch is anticipated; a differential settlement of 1/2 of the total is anticipated where foundations are bearing on like materials. This settlement is based upon the assumption that foundation will be sized and loaded in accordance with the recommendations in this report.

Lateral Pressures: Lateral forces on structures may be resisted by passive pressure acting against the sides of shallow footings and/or friction between the soil and the bottom of the footing. For resistance to lateral loads, a friction factor of 0.35 may be utilized for sliding resistance at the base of spread footings in firm native materials or engineered fill and 0.45 pcf for weathered rock. A passive resistance of 350 pcf equivalent fluid weight may be used against the side of shallow footings in firm native soil or engineered fill and 400 pcf for weathered bedrock conditions. If friction and passive pressures are combined, the lesser value should be reduced by 50 percent.

Footing Configuration: Conventional shallow foundation should be a minimum of 12 inches wide and founded a minimum of 12 inches below the lowest adjacent soil grade. Isolated pad foundations should be a minimum of 24 inches in diameter.

Foundation reinforcement should be provided by the structural engineer. The reinforcement schedule should account for typical construction issues such as load consideration, concrete cracking, and the presence of isolated irregularities. At a minimum, we recommend that continuous footing foundations be reinforced with two No. 4 reinforcing bars, one located near the bottom of the footing and one near the top of the stem wall.

All footings should be founded below an imaginary 2H:1V plane projected up from the bottoms of adjacent footings and/or parallel utility trenches, or to a depth that achieves a minimum horizontal clearance of 6 feet from the outside toe of the footings to the slope face, whichever requires a deeper excavation.

Subgrade Conditions: Footings should never be cast atop soft, loose, organic, slough, debris, nor atop subgrades covered by ice or standing water. A representative of our firm should be retained to observe all subgrades during footing excavations and prior to concrete placement so that a determination as to the adequacy of subgrade preparation can be made.

Shallow Footing / Stemwall Backfill: All footing/stemwall backfill soil should be compacted to at least 90 percent of the maximum dry density (based on ASTM D1557).

Drilled Pier Foundations

We anticipate that a drilled pier type foundation may be used for support of lighting and awning structures. For drilled piers, we recommend piers be drilled a minimum of 2 feet into competent bedrock, estimated to be approximately three feet below the existing surface grades in the majority of the Dog Park area. The following axial capacities of piers were evaluated based on previous data obtained from the site. The axial pier capacities summarized in the table below are for a single pier spaced with a minimum of 3 pile diameters on center. These capacities may be increased by 1/3 for short term wind and seismic loads. For piers spaced at less than 3

diameters on center, additional group capacity reduction effects should be taken into account in evaluating the allowable axial capacity of the pier groups.

Axial Pier Capacity for Drilled Cast-In-Place Concrete Piers

Pier Diameter (inches)	Pier Embedment (feet)	Allowable Axial Bearing Capacity (kips)
24	2	9,000
24	3	11,000

Note: * pier self weight is included

Lateral Loads: Lateral loads may be resisted by passive pressure acting against the sides of the piers. A passive pressure of 400 psf per foot of depth may be applied over 1½ pier diameters for the portion of the pier embedded in rock. If the pier footings penetrate fill to reach bedrock, lateral resistance within the fill zone should be ignored.

Construction Considerations

Precautions should be taken during pier excavations to reduce caving and raveling. The following recommendations are presented and should be followed where applicable.

- Piers should be installed under the full-time observation of YCG.
- Pier excavations should be filled with concrete as soon as possible following drilling. Pier excavations should not be left open for extended periods of time.
- In the event of soil caving or water seepage into the pier excavation, casing should be used. Casing may be pulled as the pier excavation is filled with concrete. The use of "wet" construction, such as "super-mud", is not recommended.
- Concrete should be placed and vibrated throughout the full length of the pier so that voids do not exist in either the pier base or the shaft. Placement procedures, such as tremie, should be used so that the concrete is not allowed to fall freely more than 5 feet and to prevent concrete from striking the walls of the excavations and possibly causing caving.
- Where the drilling operation might affect the concrete in an adjacent pier (i.e., where pier spacing is less than 3 diameters), drilling should not be carried out before the previously poured pier concrete has set for at least 24 hours, or as permitted by YCG.

Retaining Walls

Our design recommendations and comments regarding retaining walls for the project site are discussed below.

Foundation Design Parameters: An allowable dead plus live load bearing pressure of 2,000 psf may be used for design of retaining wall footings based a minimum of 12 inches into firm native soils or engineered fills. The allowable bearing capacity may be increased to 4,000 psf for wall footings based a minimum of 12 inches into bedrock.

Retaining Wall Lateral Pressures: Based on our observations and testing, the retaining wall should be designed to resist lateral pressure exerted from a soil media having an equivalent fluid weight as follows.

Retaining Wall Pressures

Wall Type	Wall Slope Configuration	Equivalent Fluid Weight (pcf)	Surcharge Load (psf)	Lateral Pressure Coefficient	Earthquake Load Factor
Free	Flat	45	per structural	0.35	8H ² Applied 0.6H above the base of the wall
Cantilever	2H:1V	70	per structural	0.58	
Restrained**	Flat	65	per structural	0.52	

* The surcharge loads should be applied as uniform loads over the full height of the walls as follows: Surcharge Load (psf) = (q) (K), where q = surcharge in psf, and K = coefficient of lateral pressure. Final design is the purview of the project structural engineer.

** Restrained conditions shall be defined as walls which are structurally connected to prevent flexible yielding, or rigid wall configurations (i.e. walls with numerous turning points) which prevent the yielding necessary to reduce the driving pressures from an at-rest state to an active state.

*** Section 1803.5.12 of the 2010 California Building Code states that a determination of lateral pressures on basement and retaining walls due to earthquake loading shall be provided for structures to be designed in Seismic Design Categories D, E or F (Load value derived from Wood (1973) and modified by Whitman (1991)).

Mechanically Stabilized Earth Walls: If keyed or interlocking non-mortared walls such as Keystone, Baselite, Allen Block, or rockery walls are utilized, the following soil parameters would be applicable for design within on-site, native materials:

Modular Wall Design Parameters

Internal Angle of Friction	Surcharge	Surcharge Load (psf)	Open Drainage
32°	0 psf	120 psf	14 %

Site Wall Drainage: The above criteria are based on fully drained conditions. For these conditions, we recommend that a blanket of filter material be placed behind all proposed walls. The blanket of filter material should be a minimum of 12 inches thick and should extend from the bottom of the wall to within 12 inches of the ground surface. The filter material should conform to Class One, Type B permeable material as specified in Section 68 of the California Department of Transportation Standard Specifications, current edition. A clean ¾ inch crushed rock is also acceptable, provided filter fabric is used to separate the open graded gravel/rock from the surrounding soils. The top 12 inches of wall backfill should consist of a compacted soil cap. A filter fabric should be placed on top of the gravel filter material to separate it from the soil cap. A 4 inch diameter drain pipe should be installed near the bottom of the filter blanket with perforations facing down. The drainpipe should be underlain by at least 4 inches of filter-type material. An adequate gradient should be provided along the top of the foundation to discharge water that collects behind the retaining wall to a controlled discharge system.

Slab-on-Grade Construction

It is our opinion that soil-supported slab-on-grade could be used for the various proposed improvements contingent on proper subgrade preparation. Often the geotechnical issues regarding the use of slab-on-grade floors include proper soil support and subgrade preparation, proper transfer of loads through the slab underlayment materials to the subgrade soils, and the anticipated presence or absence of moisture at or above the subgrade level. We offer the following comments and recommendations concerning support of slab-on-grade floors. The slab design (concrete mix, reinforcement, joint spacing, moisture protection, and underlayment materials) is the purview of the project Structural Engineer.

Slab Subgrade Preparation: All subgrades proposed to support slab-on-grades should be prepared and compacted to the requirements of engineered fill as discussed in the Site Grading and Improvements section of this report.

Slab Underlayment: As a minimum for slab support conditions, the slab should be underlain by a minimum 4 inch crushed rock layer and covered by a minimum 10-mil thick moisture retarding plastic membrane. An optional 1 inch blotter sand layer above the plastic membrane is sometimes used to aid in curing of the concrete. If the blotter is omitted, special curing procedures may be necessary. The blotter layer can become a reservoir for excessive moisture if inclement weather occurs prior to pouring the slab, excessive water collects in it from the concrete pour, or an external source of water enters above or bypasses the membrane. The membrane may only be functional when it is above the vapor sources. The bottom of the crushed rock layer should be above the exterior grade to act as a capillary break and not a reservoir, unless it is provided with an underdrain system. The slab design and underlayment should be in accordance with ASTM E1643 and E1745.

If the blotter sand layer is omitted (as may be required if slab design and construction is to be performed according to the 2010 Green Building Code), special wet curing procedures will be necessary. In this case, development of appropriate slab mix design and curing procedures remains the purview of the project structural engineer.

Slab Moisture Protection: Due to the potential for landscape to be present directly adjacent to the slab edge/foundation or for drainage to be altered following our involvement with the project, varying levels of moisture below, at, or above the pad subgrade level should be anticipated. The slab designer should include the potential for moisture vapor transmission when designing the slab. Our experience has shown that vapor transmission through concrete is controlled through slab thickness as well as proper concrete mix design.

It should be noted that placement of the recommended plastic membrane, proper mix design, and proper slab underlayment and detailing per ASTM E1643 and E1745 will not provide a waterproof condition. If a waterproof condition is desired, we recommend that a waterproofing expert be consulted for slab design.

Slab Thickness and Reinforcement: Geotechnical reports have historically provided minimums for slab thickness and reinforcement for general crack control. The concrete mix design and construction practices can additionally have a large impact on concrete crack control. All concrete should be anticipated to crack. As such, these minimums should not be considered to be stand alone items to address crack control, but are suggested to be considered in the slab design methodology.

In order to help control the growth of cracks in interior concrete from becoming significant, we suggest the following minimums. Interior concrete slabs-on-grade not subject to heavy loads should be a minimum of 4 inches thick. A 4 inch thick slab should be reinforced. A minimum of No. 3 deformed reinforcing bars placed at 24 inches on center both ways, at the center of the structural section is suggested. Joint spacing should be provided by the structural engineer. Troweled joints recovered with paste during finishing or "wet sawn" joints should be considered every 10 feet on center. Expansion joint felt should be provided to separate floating slabs from foundations and at least at every third joint. Cracks will tend to occur at recurrent corners, curved or triangular areas and at points of fixity. Trim bars can be utilized at right angle to the predicted crack extending 40 bar diameters past the predicted crack on each side.

Vertical Deflections: Soil-supported slab-on-grade floors can deflect downward when vertical loads are applied, due to elastic compression of the subgrade. For design of concrete floors, a modulus of subgrade reaction of $k = 150$ psi per inch would be applicable for native soils and engineered fills.

Exterior Flatwork: Exterior concrete flatwork need not be underlain by a rock cushion where non-expansive soils are encountered. However, some vertical movement of concrete should be anticipated when arranging outside concrete flatwork joints where rock is omitted. Where expansive soils are encountered, a 4 inch rock cushion under concrete flatwork and pre-saturation is recommended.

If exterior flatwork concrete is against the floor slab edge without a moisture separator it may transfer moisture to the floor slab. Expansion joint felt should be provided to separate exterior flatwork from foundations and at least at every third joint. Contraction / groove joints should be provided to a depth of at least 1/4 of the slab thickness and at a spacing of less than 30 times the slab thickness for unreinforced flatwork, dividing the slab into nearly square sections. Cracks will tend to occur at recurrent corners, curved or triangular areas and at points of fixity. Trim bars can be utilized at right angle to the predicted crack extending 40 bar diameters past the predicted crack on each side.

Drainage Adjacent to Slabs: All grades should provide rapid removal of surface water runoff; ponding water should not be allowed on building pads or adjacent to foundations or other structural improvements (during and following construction). All soils placed against foundations during finish grading should be compacted to minimize water infiltration. Finish and landscape grading should include positive drainage away from all foundations. Section 1808.7.4 of the 2010 California Building Code (CBC) states that for graded soil sites, the top of any exterior foundation shall extend above the elevation of the street gutter at the point of discharge or the inlet of an approved drainage device a minimum of 12 inches plus 2 percent. If overland flow is not achieved adjacent to buildings, the drainage device should be designed to accept flows from a 100 year event. Grades directly adjacent to foundations should be no closer than 8 inches from the top of the slab (CBC 2304.11.2.2), and weep screeds are to be placed a minimum of 4 inches clear of soil grades and 2 inches clear of concrete or other hard surfacing (CBC 2512.1.2). From this point, surface grades should slope a minimum of 2 percent away from all foundations for at least 5 feet but preferably 10 feet, and then 2 percent along a drainage swale to the outlet (CBC 1804.3). Downspouts should be tight piped via an area drain network and discharged to an appropriate non-erosive outlet away from all foundations.

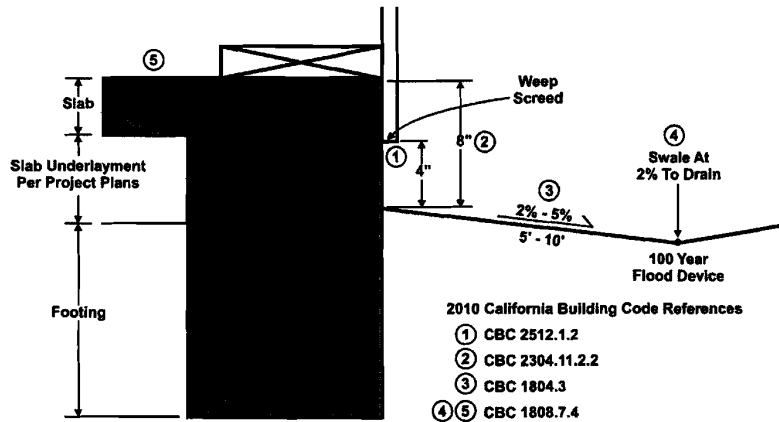

**Typical 2010 California Building Code
Drainage Requirements**

The above referenced elements pertaining to drainage of the proposed structures is provided as general acknowledgement of the California Building Code requirements, restated and graphically illustrated for ease of understanding. Surface drainage design is the purview of the

Project Architect/Civil Engineer. Review of drainage design and implementation adjacent to the building envelopes is recommended as performance of these improvements is crucial to the performance of the foundation and construction of rigid improvements.

Drainage Considerations

In order to maintain the engineering strength characteristics of the soil presented for use in this Geotechnical Engineering Study, maintenance of the site will need to be performed. This maintenance generally includes, but is not limited to, proper drainage and control of surface and subsurface water which could affect structural support and fill integrity. A difficulty exists in determining which areas are prone to the negative impacts resulting from high moisture conditions due to the diverse nature of potential sources of water; some of which are outlined in the paragraph below. We suggest that measures be installed to minimize exposure to the adverse effects of moisture, but this will not guarantee that excessive moisture conditions will not affect the structure.

Some of the diverse sources of moisture could include water from landscape irrigation, annual rainfall, offsite construction activities, runoff from impermeable surfaces, collected and channeled water, and water perched in the subsurface soils on the bedrock horizon or present in fractures in the weathered bedrock. Some measures that can be employed to minimize the buildup of moisture include, but are not limited to proper backfill materials and compaction of utility trenches; grout plugs at foundation penetrations; collection and channeling of drained water from impermeable surfaces (i.e. roofs, concrete or asphalt paved areas); installation of subdrain/cut-off drain provisions; utilization of low flow irrigation systems; education of proper design and maintenance of landscaping and drainage facilities that the landscaper installs.

Post Construction: All drainage related issues may not become known until after construction and landscaping are complete. Therefore, some mitigation measures may be necessary following site development. Landscape watering is typically the largest source of water infiltration into the subgrade. Given the soil conditions on site, excessive or even normal landscape watering may contribute to groundwater levels rising, which could contribute to moisture related problems and/or cause distress to foundations and slabs, pavements, and underground utilities, as well as creating a nuisance where seepage occurs. In order to mitigate these conditions, additional subdrainage measures may be necessary. On foothill developments constructed with cut/fill pads on shallow bedrock conditions, seepage may not be apparent until post construction. In order to mitigate these conditions additional subdrainage measures may be necessary.

6.0 DESIGN REVIEW AND CONSTRUCTION MONITORING

The design plans and specifications should be reviewed and accepted by Youngdahl Consulting Group, Inc. prior to contract bidding. A review should be performed to determine whether the recommendations contained within this report are still applicable and/or are properly reflected and incorporated into the project plans and specifications.

Construction Monitoring

Construction monitoring is a continuation of the findings and recommendations provided in this report. It is essential that our representative be involved with all grading activities in order for us to provide supplemental recommendations as field conditions dictate. Youngdahl Consulting Group, Inc. should be notified at least two working days before site clearing or grading operations commence, and should observe the stripping of deleterious material, overexcavation of existing fills or loose/soft soils and provide consultation to the Grading Contractor in the field.

Low Impact Development Standards

Low Impact Development or LID standards have become a consideration for many projects in the region. LID standards are intended to address and mitigate urban storm water quality concerns. These methods include the use of Source Controls, Run-off Reduction and Treatment Controls. For the purpose of this report use of Run-off Reduction measures and some Treatment Controls may impact geotechnical recommendations for the project.

Youngdahl Consulting Group, Inc. did not perform any percolation or infiltration testing for the site as part of the Geotechnical Investigation. A review of soil survey and the data collected from test pits indicate that soils within the project are Hydrologic Soil Group D (low permeability). Based on this condition, use of infiltration type LID methods (infiltration trenches, dry wells, infiltration basins, permeable pavements, etc.) should not be considered without addressing applicable geotechnical considerations/implications. As such, use of any LID measure that would require infiltration of discharge water to surfaces adjacent to structures/pavement or include infiltration type measures should be reviewed by Youngdahl Consulting Group, Inc. during the design process.

Post Construction Monitoring

As described in Post Construction section of this report, all drainage related issues may not become known until after construction and landscaping are complete. Youngdahl Consulting Group, Inc. can provide consultation services upon request that relate to proper design and installation of drainage features during and following site development. In addition, if the development includes use of LID measures maintenance of those features in conformance with the standard of practice and documentation from the designer will be necessary. The impact from infiltration or run-off reduction measures to engineered structures and foundations may not become apparent until after construction. We recommend that all LID measures be inspected and maintained as documented by the designer and if adverse impacts are noted related to the structure or site that Youngdahl Consulting Group, Inc. be retained to review the LID measure and provide additional consulting and options.

7.0 LIMITATIONS AND UNIFORMITY OF CONDITIONS

1. This report has been prepared for the exclusive use of EDHCSD and their consultants for specific application to the Dog Park project. Youngdahl Consulting Group, Inc. has endeavored to comply with generally accepted geotechnical engineering practice common to the local area. Youngdahl Consulting Group, Inc. makes no other warranty, expressed or implied.
2. As of the present date, the findings of this report are valid for the property studied. With the passage of time, changes in the conditions of a property can occur whether they be due to natural processes or to the works of man on this or adjacent properties. Legislation or the broadening of knowledge may result in changes in applicable standards. Changes outside of our control may cause this report to be invalid, wholly or partially. Therefore, this report should not be relied upon after a period of three years without our review nor should it be used or is it applicable for any properties other than those studied.
3. Section 107.3.4.1 of the International Building Code and Appendix Chapter 1 of the 2010 California Building Code states that, in regard to the design professional in responsible charge, the building official shall be notified in writing by the owner if the registered design professional in responsible charge is changed or is unable to continue to perform the duties. **WARNING:** Do not apply any of this report's conclusions or recommendations if the nature, design, or location of the facilities is changed. If changes are contemplated, Youngdahl



Consulting Group, Inc. must review them to assess their impact on this report's applicability. Also note that Youngdahl Consulting Group, Inc. is not responsible for any claims, damages, or liability associated with any other party's interpretation of this report's subsurface data or reuse of this report's subsurface data or engineering analyses without the express written authorization of Youngdahl Consulting Group, Inc.

4. The analyses and recommendations contained in this report are based on limited windows into the subsurface conditions and data obtained from subsurface exploration. The methods used indicate subsurface conditions only at the specific locations where samples were obtained, only at the time they were obtained, and only to the depths penetrated. Samples cannot be relied on to accurately reflect the strata variations that usually exist between sampling locations. Should any variations or undesirable conditions be encountered during the development of the site, Youngdahl Consulting Group, Inc., will provide supplemental recommendations as dictated by the field conditions.
5. The recommendations included in this report have been based in part on assumptions about strata variations that may be tested only during earthwork. Accordingly, these recommendations should not be applied in the field unless Youngdahl Consulting Group, Inc. is retained to perform construction observation and thereby provide a complete professional geotechnical engineering service through the observational method. Youngdahl Consulting Group, Inc. cannot assume responsibility or liability for the adequacy of its recommendations when they are used in the field without Youngdahl Consulting Group, Inc. being retained to observe construction. Unforeseen subsurface conditions containing soft native soils, loose or previously placed non-engineered fills should be a consideration while preparing for the grading of the property. It should be noted that it is the responsibility of the owner or his/her representative to notify Youngdahl Consulting Group, Inc., in writing, a minimum of 48 hours before any excavations commence at the site.
6. Our experience has shown that vapor transmission through concrete is controlled through proper concrete mix design. As such, proper control of moisture vapor transmission should be considered in the design of the slab as provided by the project architect, structural or civil engineer. It should be noted that placement of the recommended plastic membrane, proper mix design, and proper slab underlayment and detailing per ASTM E1643 and E1745 will not provide a waterproof condition. If a waterproof condition is desired, we recommend that a waterproofing expert be consulted for slab design.
7. Following site development, additional water sources (ie. landscape watering, downspouts) are generally present. The presence of low permeability materials can prohibit rapid dispersion of surface and subsurface water drainage. Utility trenches typically provide a conduit for water distribution. Provisions may be necessary to mitigate adverse effects of perched water conditions. Mitigation measures may include the construction of cut-off systems and/or plug and drain systems. Close coordination between the design professionals regarding drainage and subdrainage conditions may be warranted.

Seepage may be observed emanating from the cut slopes following their excavation during the following rainy season or following development of the areas above the cut. Generally this seepage is not enough flow to be a stability issue to the cut slope, but may be an issue for the owner of the lot at the base of the cut from a surface drainage and standing water (damp spot) standpoint.



CHECKLIST OF RECOMMENDED SERVICES

	Item Description	Recommended	Not Anticipated
1	Provide foundation design parameters	Included	
2	Review grading plans and specifications	√	
3	Review foundation plans and specifications	√	
4	Observe and provide recommendations regarding demolition	√	
5	Observe and provide recommendations regarding site stripping	√	
6	Observe and provide recommendations on moisture conditioning removal, and/or precompaction of unsuitable existing soils	√	
7	Observe and provide recommendations on the installation of subdrain facilities	√	
8	Observe and provide testing services on fill areas and/or imported fill materials	√	
9	Review as-graded plans and provide additional foundation recommendations, if necessary	√	
10	Observe and provide compaction tests on storm drains, water lines and utility trenches	√	
11	Observe foundation excavations and provide supplemental recommendations, if necessary, prior to placing concrete	√	
12	Observe and provide moisture conditioning recommendations for foundation areas and slab-on-grade areas prior to placing concrete	√	
13	Provide design parameters for retaining walls	√	
14	Provide finish grading and drainage recommendations	Included	
15	Provide geologic observations and recommendations for keyway excavations and cut slopes during grading	√	
16	Excavate and recompact all test pits within structural areas	√	

APPENDIX A

Field Study

Vicinity Map

Site Plan

Logs of Exploratory Test Pits

Soil Classification Chart and Log Exploration

Introduction

The contents of this appendix shall be integrated with the geotechnical engineering study of which it is a part. They shall not be used in whole or in part as a sole source for information or recommendations regarding the subject site.

Field study

Our field study included a site reconnaissance by a Youngdahl Consulting Group, Inc., representative followed by a subsurface exploration program conducted on 22 October 2013, which included the excavation of 3 test pits under his direction at the approximate locations shown on Figure A-2, this Appendix. Excavation of the test pits was accomplished with a motorized auger, supplied by the EDHCSD. As the excavation proceeded some nuclear gauge tests (ASTM D2922 and D3017) were performed to obtain the in place dry density and moisture content. Bulk and bag samples were also collected from the pits.

The Exploratory Test Boring/Pit Logs describe the vertical sequence of soils and materials encountered in each test pit, based primarily on our field classifications and supported by our subsequent laboratory examination and testing. Where a soil contact was observed to be gradual, our logs indicate the average contact depth. Our logs also graphically indicate the sample type, sample number and approximate depth of each soil sample obtained from the test pits.

The soils encountered were logged during excavation and provide the basis for the "Logs of Test Pits", Figures A-3 through A-4, this Appendix. These logs show a graphic representation of the soil profile, the location and depths at which samples were collected.

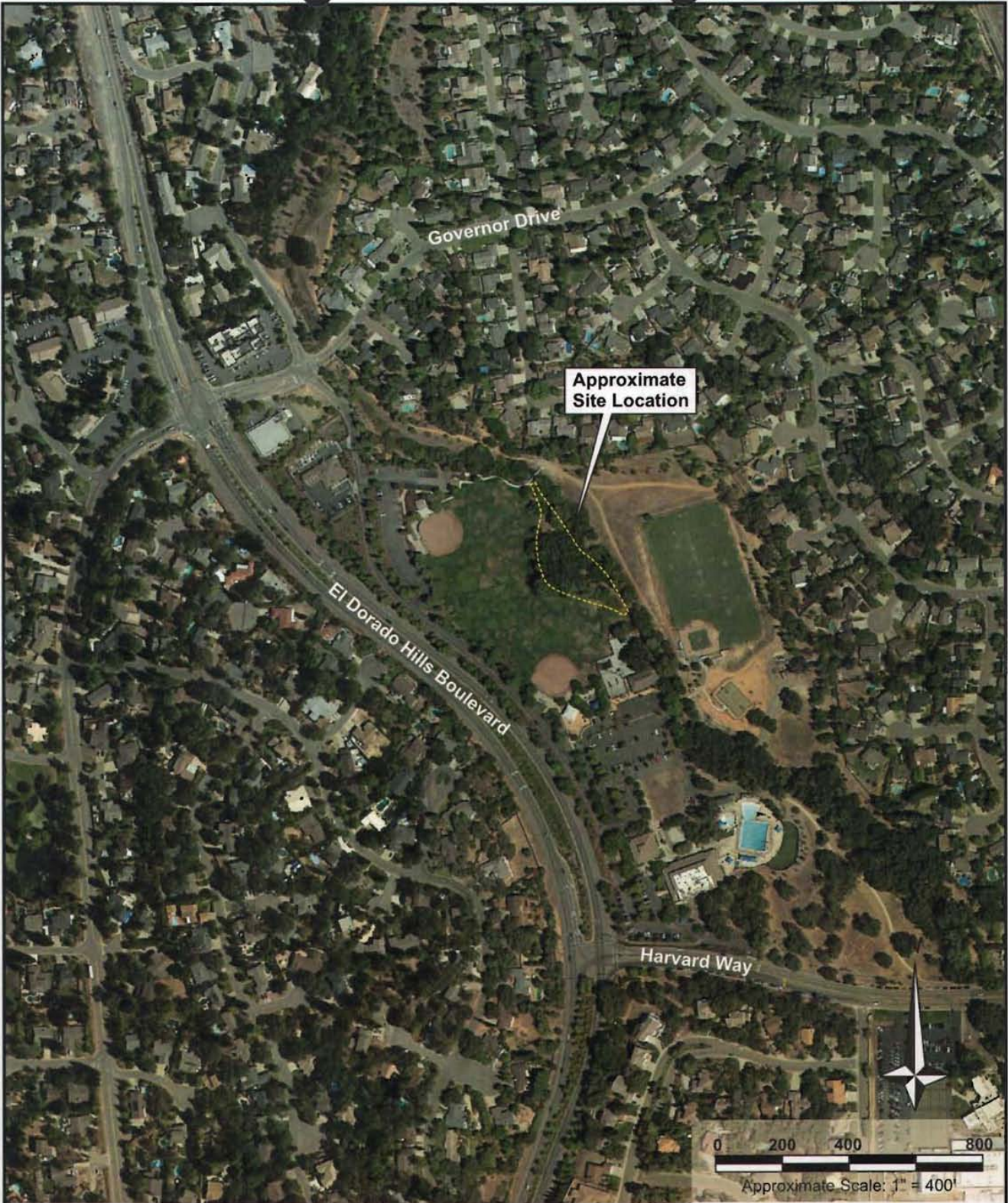

BASE MAP REFERENCE: Google Earth, Aerial Data Dated 8-13-2013

 <p>GEOTECHNICAL • ENVIRONMENTAL • MATERIALS TESTING</p>	<p>Project No.: E02261.021</p> <p>October 2013</p>	<p>VICINITY MAP El Dorado Hills Community Services District - New Dog Park El Dorado Hills, California</p>	<p>FIGURE A-1</p>
---	--	---	-------------------------------------



BASE MAP REFERENCE: Illustrative Site Plan for Proposed Dog Park, El Dorado Community Services District

TP-1  = Approximate Hand Auger Locations

YOUNGDAHL
 CONSULTING GROUP, INC.
 GEOTECHNICAL • ENVIRONMENTAL • MATERIALS TESTING

Project No.: E02261.021
 October 2013

SITE PLAN
 El Dorado Hills Community Services District - New Dog Park
 El Dorado Hills, California

FIGURE A-2

Logged By: DHR	Date: 22 October 2013	Lat / Lon: 38.68533 / -121.07622	Pit No. TP-1
Equipment: Honda 5.5 Horsepower Motorized Auger With 8" Bit		Elevation: ~ 723'	

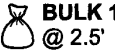
Depth (Feet)	Geotechnical Description & Unified Soil Classification	Sample	Tests & Comments
@ 0 - 2.5'	Red brown sandy SILT (ML) with trace gravel, medium stiff, dry (NATIVE)	 BULK 1 @ 2.5'	<i>Light grasses, scrub and mature oaks</i> Field moisture density test at 0' DD = 117.4 pcf MC = 8.8%
	Test pit terminated at 2.5' (Limits of machine) No free groundwater encountered No caving noted		

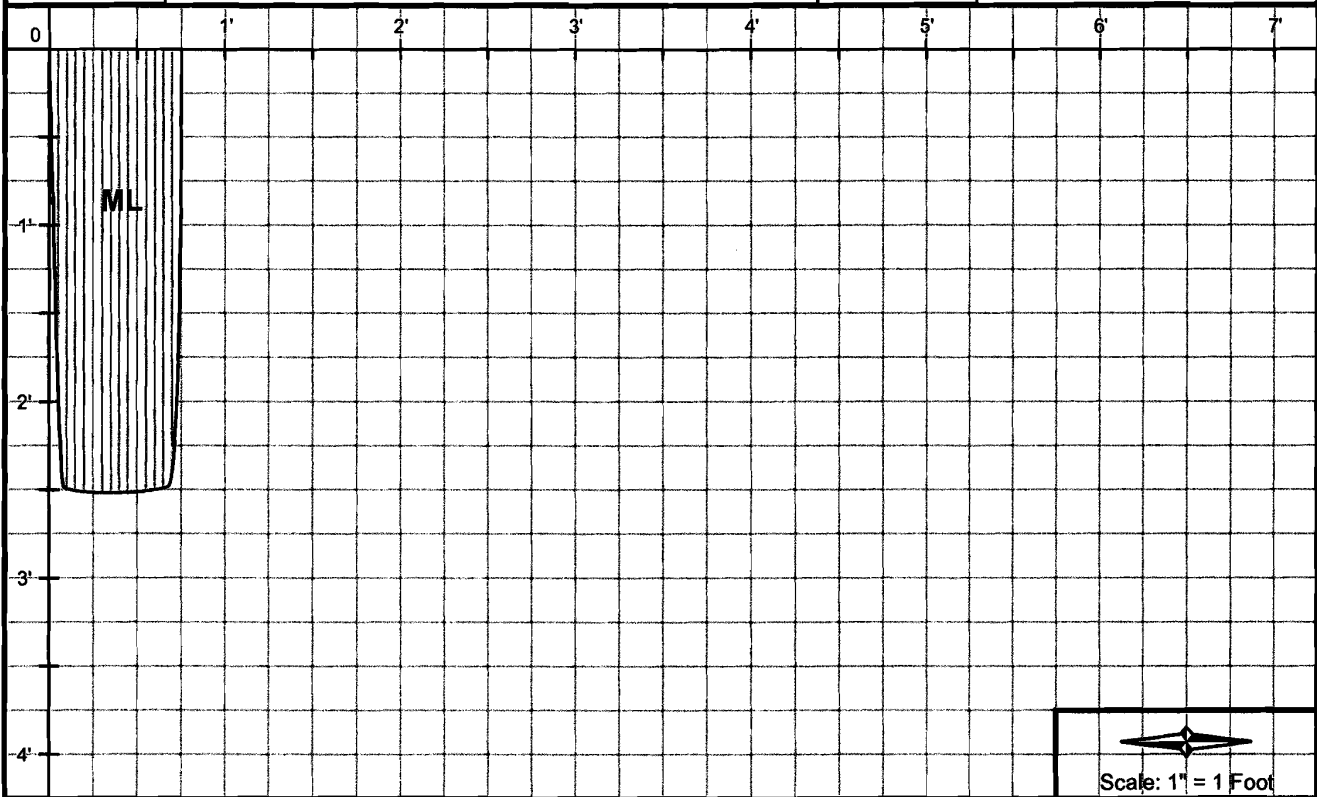

Note: The test pit log indicates subsurface conditions only at the specific location and time noted. Subsurface conditions, including groundwater levels, at other locations of the subject site may differ significantly from conditions which, in the opinion of Youngdahl Consulting Group, Inc., exist at the sampling locations. Note, too, that the passage of time may affect conditions at the sampling locations.

 GEOTECHNICAL • ENVIRONMENTAL • MATERIALS TESTING	Project No.: E02261.021	HAND AUGER LOG El Dorado Hills Community Services District - New Dog Park El Dorado Hills, California	FIGURE A-3
	October 2013		

Logged By: DHR	Date: 22 October 2013	Lat / Lon: 38.68547 / -121.07632	Pit No. TP-2
Equipment: Honda 5.5 Horsepower Motorized Auger With 8" Bit		Elevation: ~ 726'	

Depth (Feet)	Geotechnical Description & Unified Soil Classification	Sample	Tests & Comments
@ 0 - 1.3'	Yellow brown sandy SILT (ML) with few gravel, medium stiff, dry (NATIVE)		<i>Light grasses</i> Field moisture density test at 0' <i>DD = 120.3 pcf MC = 6.9%</i>
@ 1.3' - 1.5'	Gray brown metavolcanic BEDROCK , slightly weathered, indurated, closely fractured		
	Test pit terminated at 1.5' (practical refusal - 2" / 2 Minutes) No free groundwater encountered No caving noted		

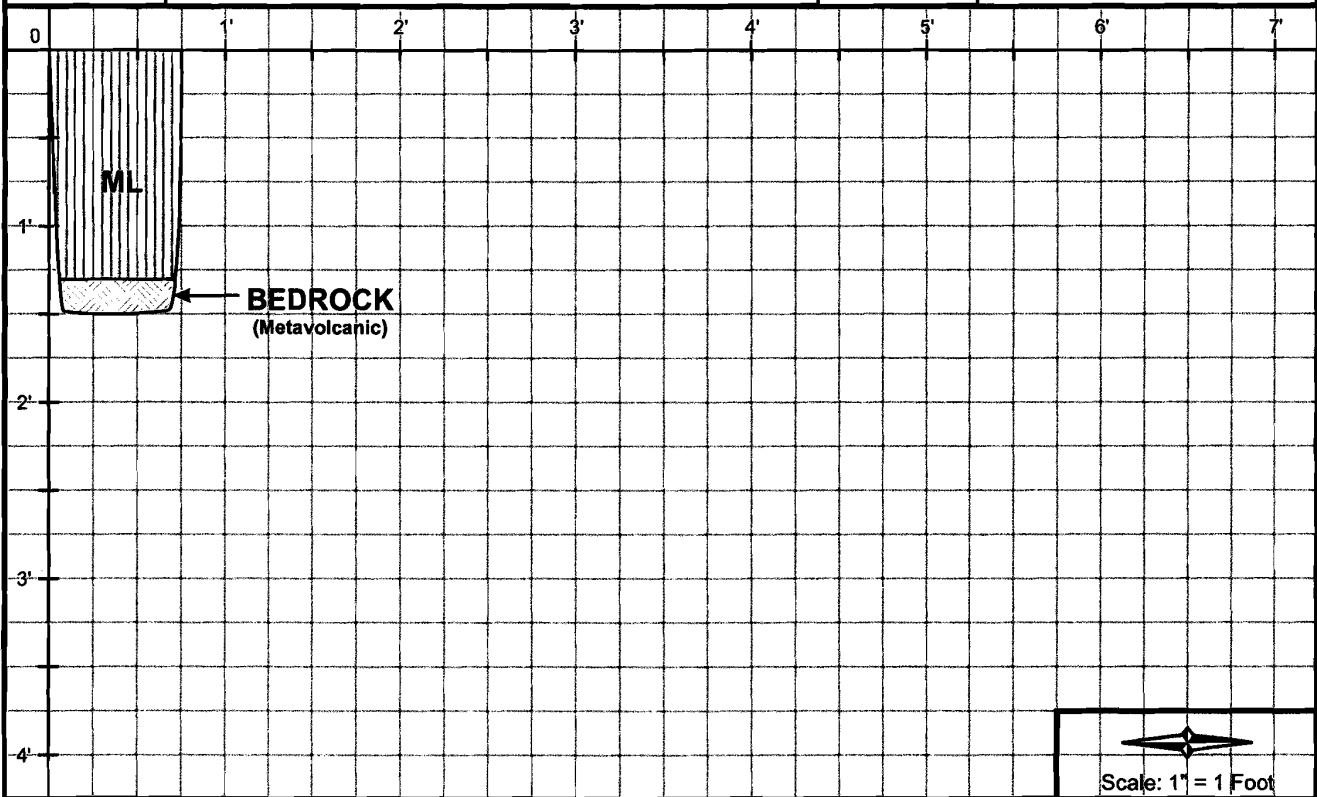

Note: The test pit log indicates subsurface conditions only at the specific location and time noted. Subsurface conditions, including groundwater levels, at other locations of the subject site may differ significantly from conditions which, in the opinion of Youngdahl Consulting Group, Inc., exist at the sampling locations. Note, too, that the passage of time may affect conditions at the sampling locations.

 YOUNGDAHL CONSULTING GROUP, INC. <small>GEOTECHNICAL • ENVIRONMENTAL • MATERIALS TESTING</small>	Project No.: E02261.021	HAND AUGER LOG El Dorado Hills Community Services District - New Dog Park El Dorado Hills, California	FIGURE A-4
	October 2013		

Logged By: DHR	Date: 22 October 2013	Lat / Lon: 38.68487 / -121.07549	Pit No. TP-3
Equipment: Honda 5.5 Horsepower Motorized Auger With 8" Bit		Elevation: ~ 720'	

Depth (Feet)	Geotechnical Description & Unified Soil Classification	Sample	Tests & Comments
@ 0 - 10"	Light brown sandy SILT (ML) with trace gravel, medium stiff, dry (NATIVE)	 BULK 2 @ 10"	Light grasses Field moisture density test at 0' DD = 118.9 pcf MC = 7.2%
@ 10" - 1'	Gray brown metavolcanic BEDROCK , slightly weathered, indurated, closely fractured		
	Test pit terminated at 1' (practical refusal - 2" / 2 Minutes) No free groundwater encountered No caving noted		

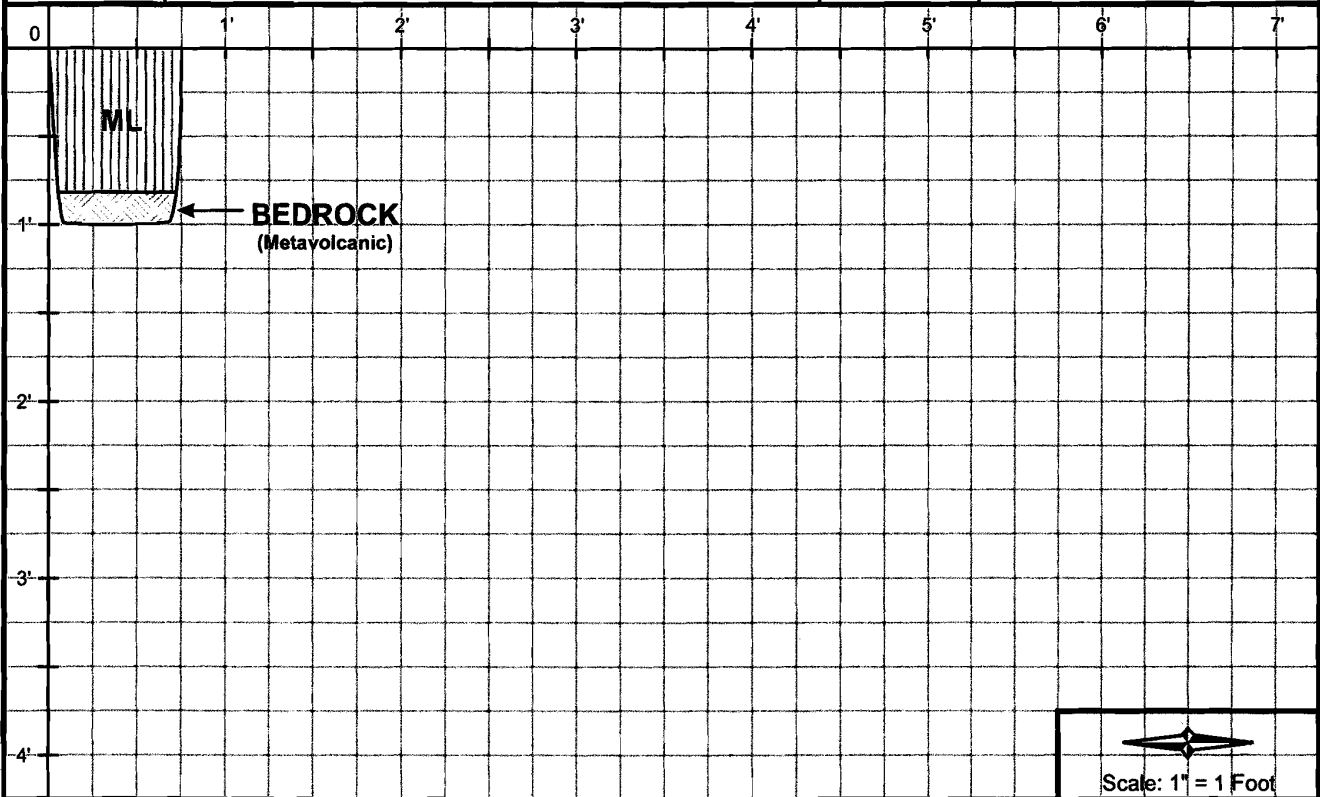

Note: The test pit log indicates subsurface conditions only at the specific location and time noted. Subsurface conditions, including groundwater levels, at other locations of the subject site may differ significantly from conditions which, in the opinion of Youngdahl Consulting Group, Inc., exist at the sampling locations. Note, too, that the passage of time may affect conditions at the sampling locations.

 GEOTECHNICAL • ENVIRONMENTAL • MATERIALS TESTING	Project No.: E02261.021	HAND AUGER LOG El Dorado Hills Community Services District - New Dog Park El Dorado Hills, California	FIGURE A-5
	October 2013		

UNIFIED SOIL CLASSIFICATION SYSTEMS

MAJOR DIVISION		SYMBOLS	TYPICAL NAMES		
COARSE GRAINED SOILS Over 50% > #200 sieve	GRAVELS Over 50% > #4 sieve	Clean GRAVELS With Little Or No Fines	GW Well graded GRAVELS, GRAVEL-SAND mixtures		
			GP Poorly graded GRAVELS, GRAVEL-SAND mixtures		
		GRAVELS With Over 12% Fines	GM Silty GRAVELS, poorly graded GRAVEL-SAND-SILT mixtures		
			GC Clayey GRAVELS, poorly graded GRAVEL-SAND-CLAY mixtures		
	SANDS Over 50% < #4 sieve	Clean SANDS With Little Or No Fines	SW Well graded SANDS, gravelly SANDS		
			SP Poorly graded SANDS, gravelly SANDS		
		SANDS With Over 12% Fines	SM Silty SANDS, poorly graded SAND-SILT mixtures		
			SC Clayey SANDS, poorly graded SAND-CLAY mixtures		
			FINE GRAINED SOILS Over 50% < #200 sieve	SILTS & CLAYS Liquid Limit < 50	ML Inorganic SILTS, silty or clayey fine SANDS, or clayey SILTS with plasticity
					CL Inorganic CLAYS of low to medium plasticity, gravelly, sandy, or silty CLAYS, lean CLAYS
OL Organic CLAYS and organic silty CLAYS of low plasticity					
SILTS & CLAYS Liquid Limit > 50	MH Inorganic SILTS, micaceous or diamaceous fine sandy or silty soils, elastic SILTS				
	CH Inorganic CLAYS of high plasticity, fat CLAYS				
	OH Organic CLAYS of medium to high plasticity, organic SILTS				
HIGHLY ORGANIC CLAYS	PT PEAT & other highly organic soils				

PLASTICITY CHART

USED FOR CLASSIFICATION OF FINE GRAINED SOILS

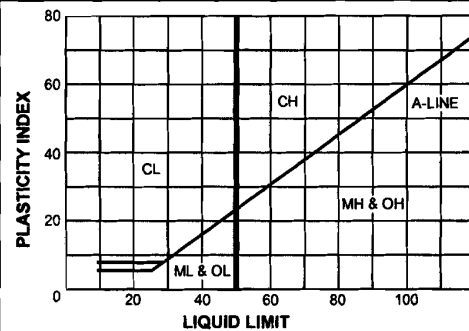

SAMPLE DRIVING RECORD

BLOWS PER FOOT	DESCRIPTION
25	25 Blows drove sampler 12 inches, after initial 6 inches of seating
50/7"	50 Blows drove sampler 7 inches, after initial 6 inches of seating
50/3"	50 Blows drove sampler 3 inches during or after initial 6 inches of seating

Note: To avoid damage to sampling tools, driving is limited to 50 blows per 6 inches during or after seating interval.

SOIL GRAIN SIZE

U.S. STANDARD SIEVE	6"	3"	¾"	4	10	40	200				
	BOULDER		COBBLE		GRAVEL		SAND			SILT	CLAY
			COARSE	FINE	COARSE	MEDIUM	FINE				
SOIL GRAIN SIZE IN MILLIMETERS	150	75	19	4.75	2.0	.425	0.075	0.002			

KEY TO PIT & BORING SYMBOLS

	Standard Penetration test
	2.5" O.D. Modified California Sampler
	3" O.D. Modified California Sampler
	Shelby Tube Sampler
	2.5" Hand Driven Liner
	Bulk Sample
	Water Level At Time Of Drilling
	Water Level After Time Of Drilling
	Perched Water

KEY TO PIT & BORING SYMBOLS

	Joint
	Foliation
	Water Seepage
NFWE	No Free Water Encountered
FWE	Free Water Encountered
REF	Sampling Refusal
DD	Dry Density (pcf)
MC	Moisture Content (%)
LL	Liquid Limit
PI	Plasticity Index
PP	Pocket Penetrometer
UCC	Unconfined Compression (ASTM D2166)
TVS	Pocket Torvane Shear
EI	Expansion Index (ASTM D4829)
Su	Undrained Shear Strength