

TENTATIVE MAP WILSON ESTATES

COUNTY OF EL DORADO

AUGUST, 2014

STATE OF CALIFORNIA

OWNERS OF RECORD

LISA VOGELSSANG
CATHERINE RYAN
JULIE RYAN

1615 GREENWICH STREET
SAN FRANCISCO, CA 94123

APPLICANT

CTA ENGINEERING & SURVEYING
3233 MONIER CIRCLE
RANCHO CORDOVA, CA 95742

ENGINEER

cta Engineering & Surveying

Civil Engineering • Land Surveying • Land Planning
3233 Monier Circle, Rancho Cordova, CA 95742
T (916) 836-0910 • F (916) 836-2470 • www.cta.net

MAP SCALE

1" = 60'

CONTOUR INTERVAL

CONTOUR INTERVAL = 2 FEET

SOURCE OF TOPOGRAPHY

AERIAL PHOTOGRAPHY

SECTION, TOWNSHIP and RANGE

PORTION OF SECTIONS 13, 14 & 23, T.10N., R.8E., M.D.M.

ASSESSOR'S PARCEL NUMBERS

A.P.N. 126-070-22, 126-070-23, 126-070-30

GENERAL PLAN

HDR IN A COMMUNITY REGION

PRESENT ZONING

R1A

PROPOSED ZONING

R1A - PD / OS-PD (ZONE BOUNDARY ESTABLISHED BY FINAL MAP)

TOTAL AREA

28.18 ACRES

TOTAL NUMBER OF PARCELS

RESIDENTIAL LOTS (1-28)	16.51 AC
PRIVATE ROAD LOT (LOT R)	1.45 AC
LETTERED LOT (B), LOT (C)	
OPEN SPACE, DRAINAGE & WATERLINES	8.41 AC 30% OPEN SPACE
NEW CONNECTION (LOT A)	0.55 AC
MALCOLM DIXON ROADWAY DEDICATION	0.62 AC
GREEN VALLEY ROAD ROADWAY DEDICATION	0.54 AC
TOTAL AREA	28.18 AC

MINIMUM LOT AREA

20,004 SQUARE FEET

WATER SUPPLY and SEWAGE DISPOSAL

EL DORADO IRRIGATION DISTRICT

PROPOSED STRUCTURAL FIRE PROTECTION

EL DORADO HILLS COUNTY WATER DISTRICT (FIRE DEPARTMENT)

DATE OF PREPARATION

AUGUST, 2014

PHASING PLAN NOTICE

THE SUBDIVIDER MAY FILE MULTIPLE FINAL MAPS FOR THIS PROJECT. THE SUBDIVIDER SHALL NOT BE REQUIRED TO DEFINE THE NUMBER OR CONFIGURATION OF THE PROPOSED MULTIPLE FINAL MAPS. (PER THE SUBDIVISION MAP ACT, SECTION 66456.1)

ENGINEER'S CERTIFICATE

I HEREBY CERTIFY THAT TO THE BEST OF MY KNOWLEDGE THE LAND DEVELOPMENT KNOWN AS WILSON ESTATES HAS BEEN DESIGNED IN ACCORDANCE WITH THE SPECIFICATIONS AND GUIDELINES ESTABLISHED BY THE COUNTY OF EL DORADO.

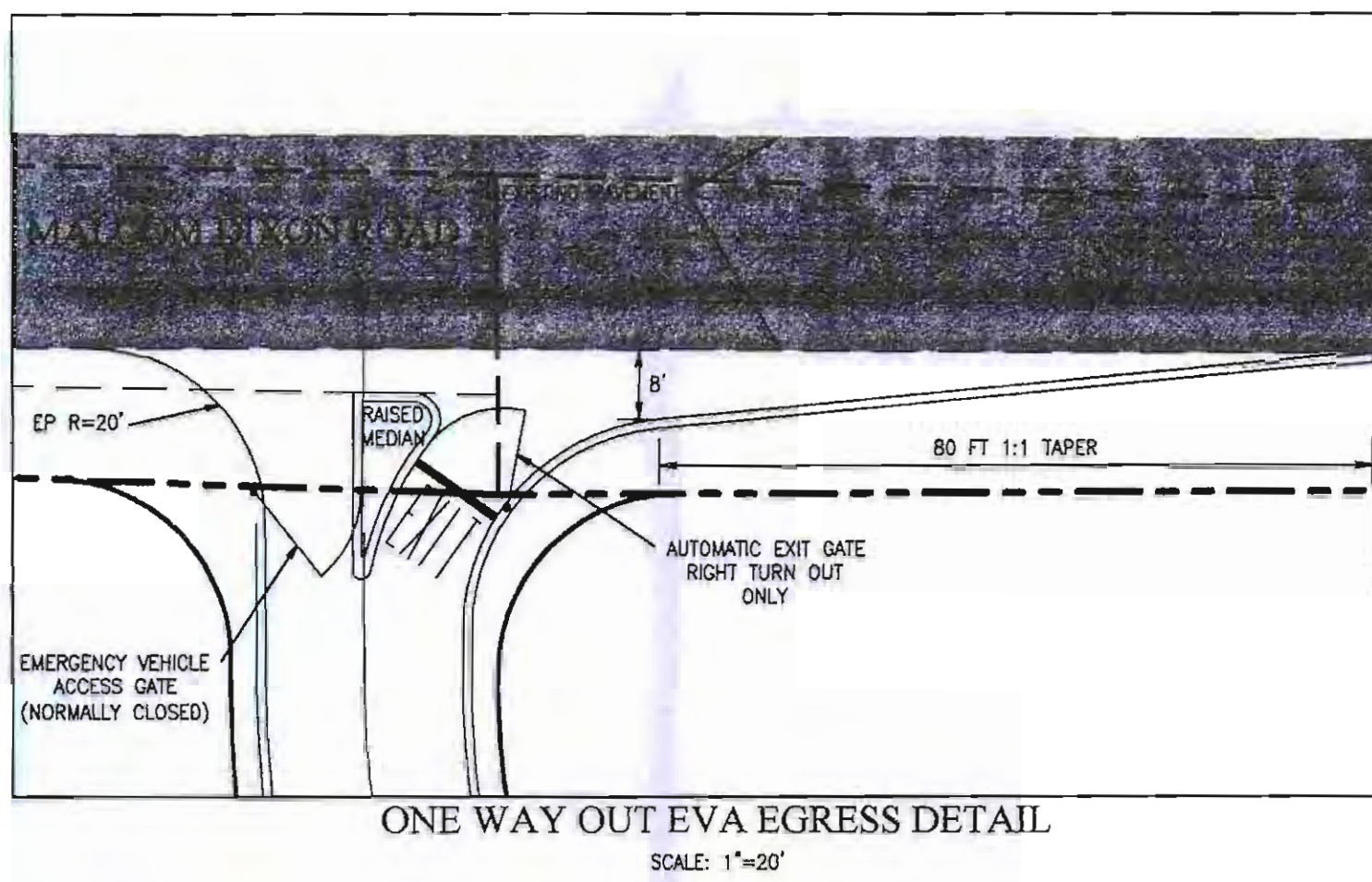

ONE WAY OUT EVA EGRESS DETAIL
SCALE: 1"=30"

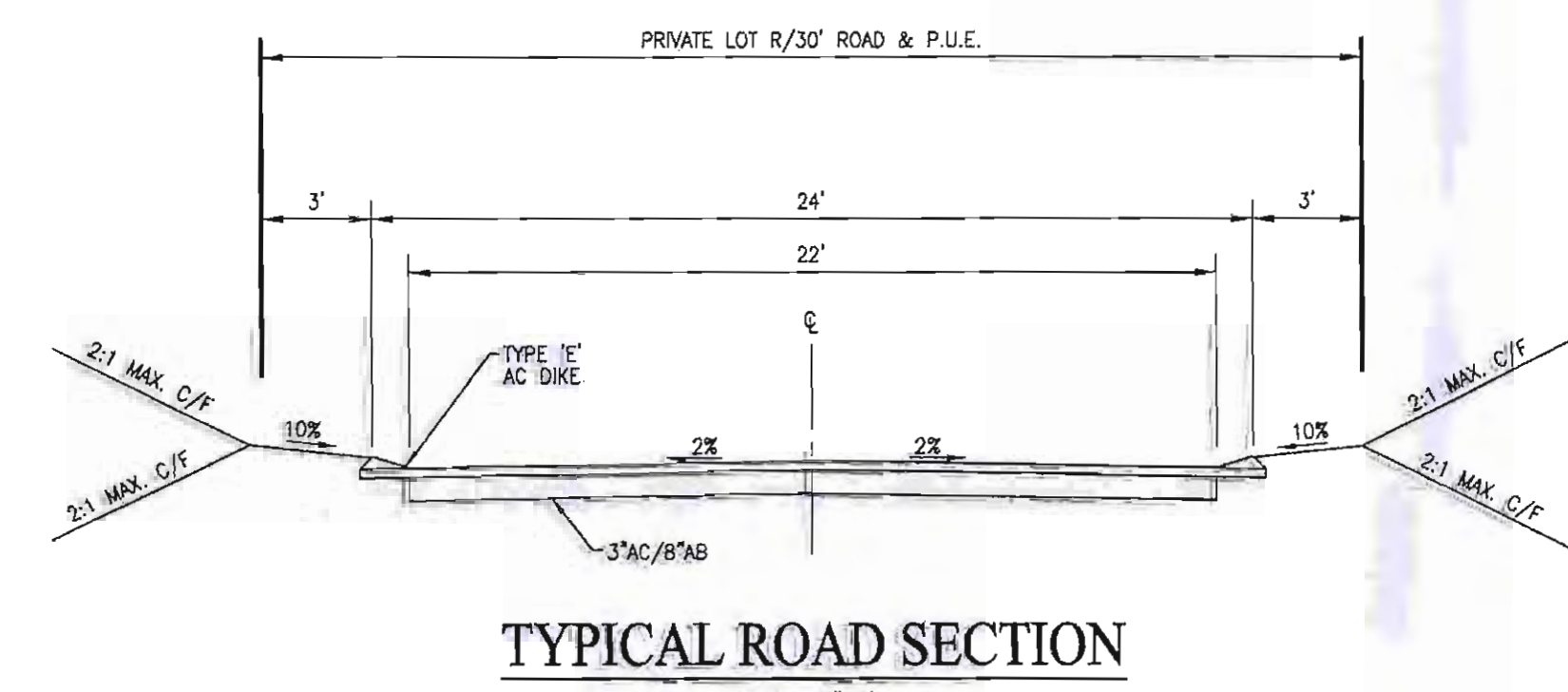
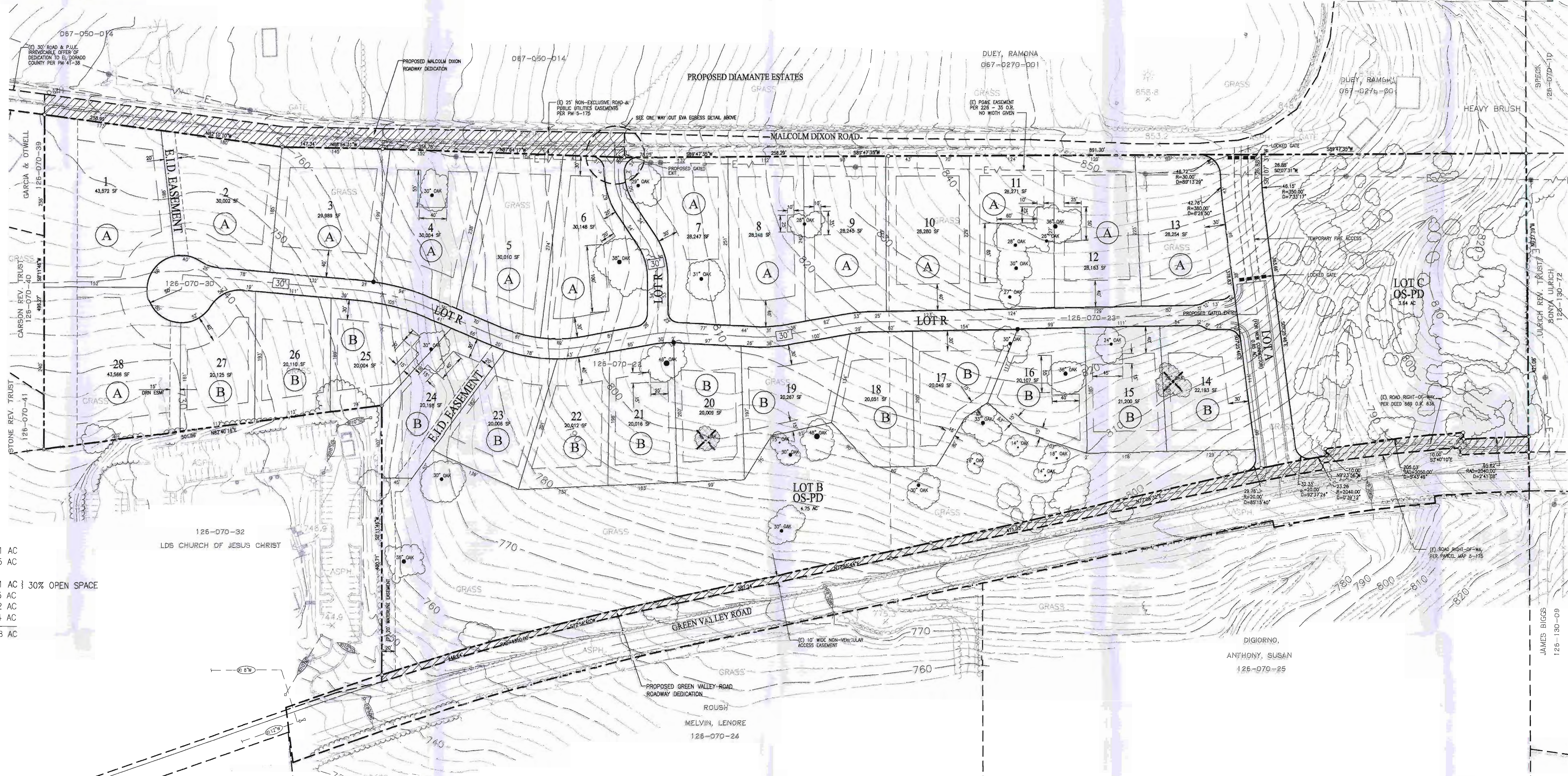

TYPICAL ROAD SECTION
SCALE: 1"=5"

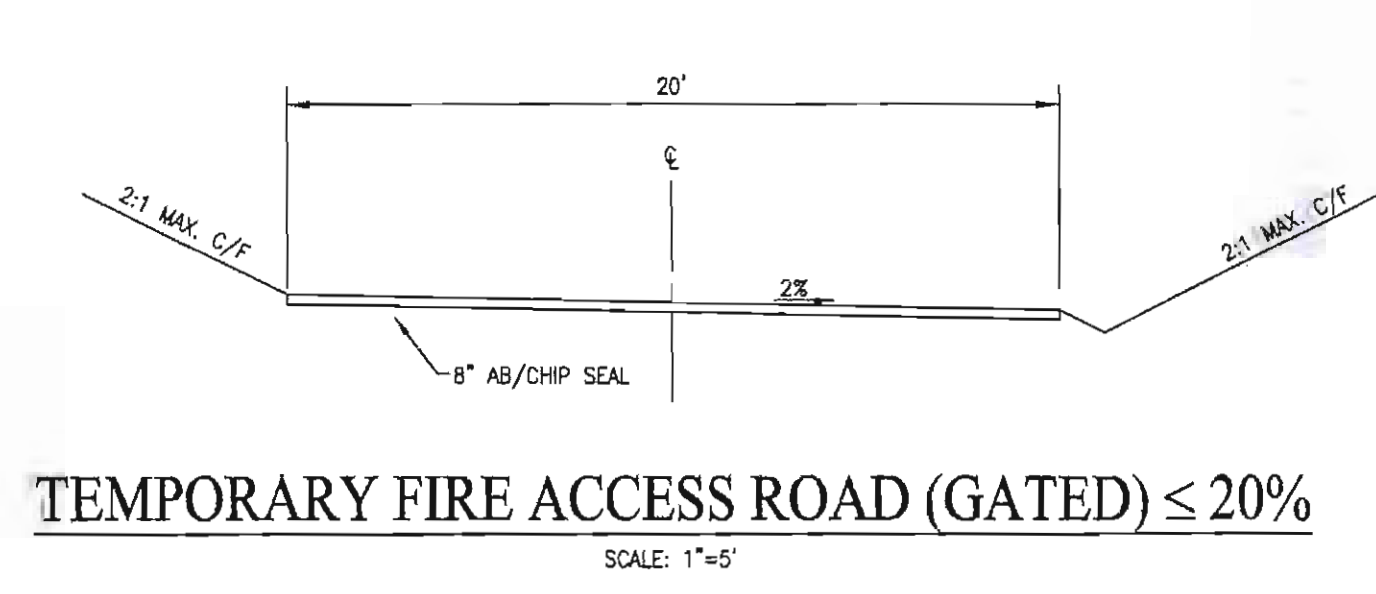

TEMPORARY FIRE ACCESS ROAD (GATED) ≤ 20%
SCALE: 1"=5"

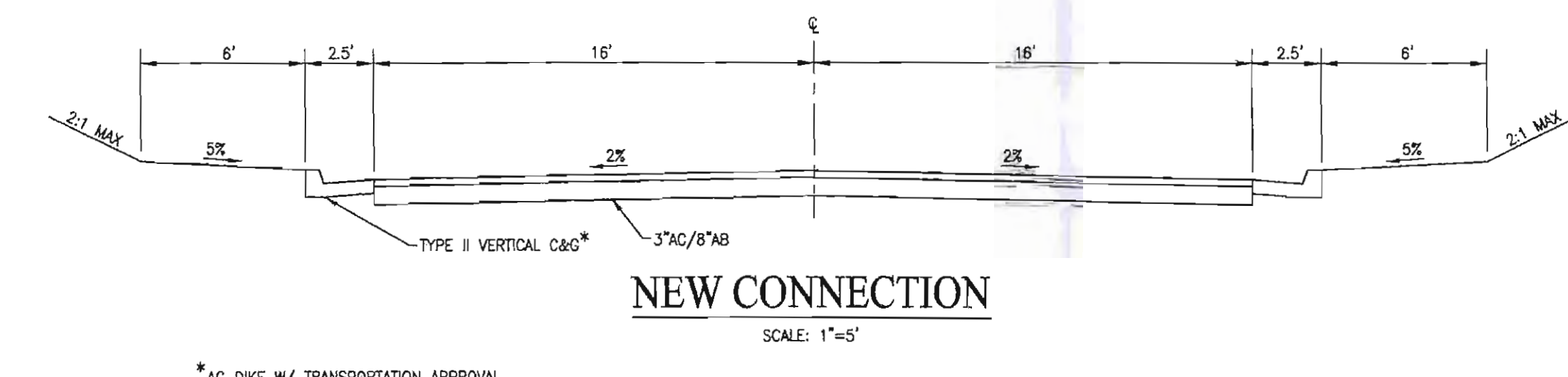

NEW CONNECTION
SCALE: 1"=5"

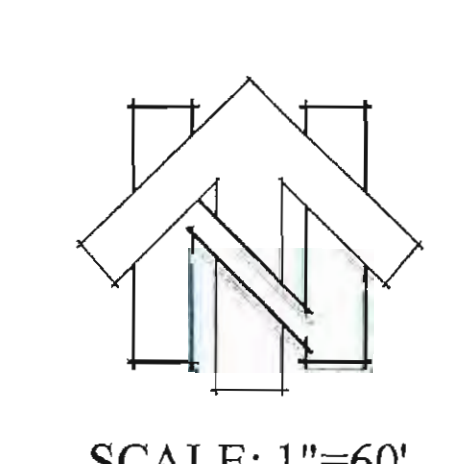

SCALE: 1"=60'

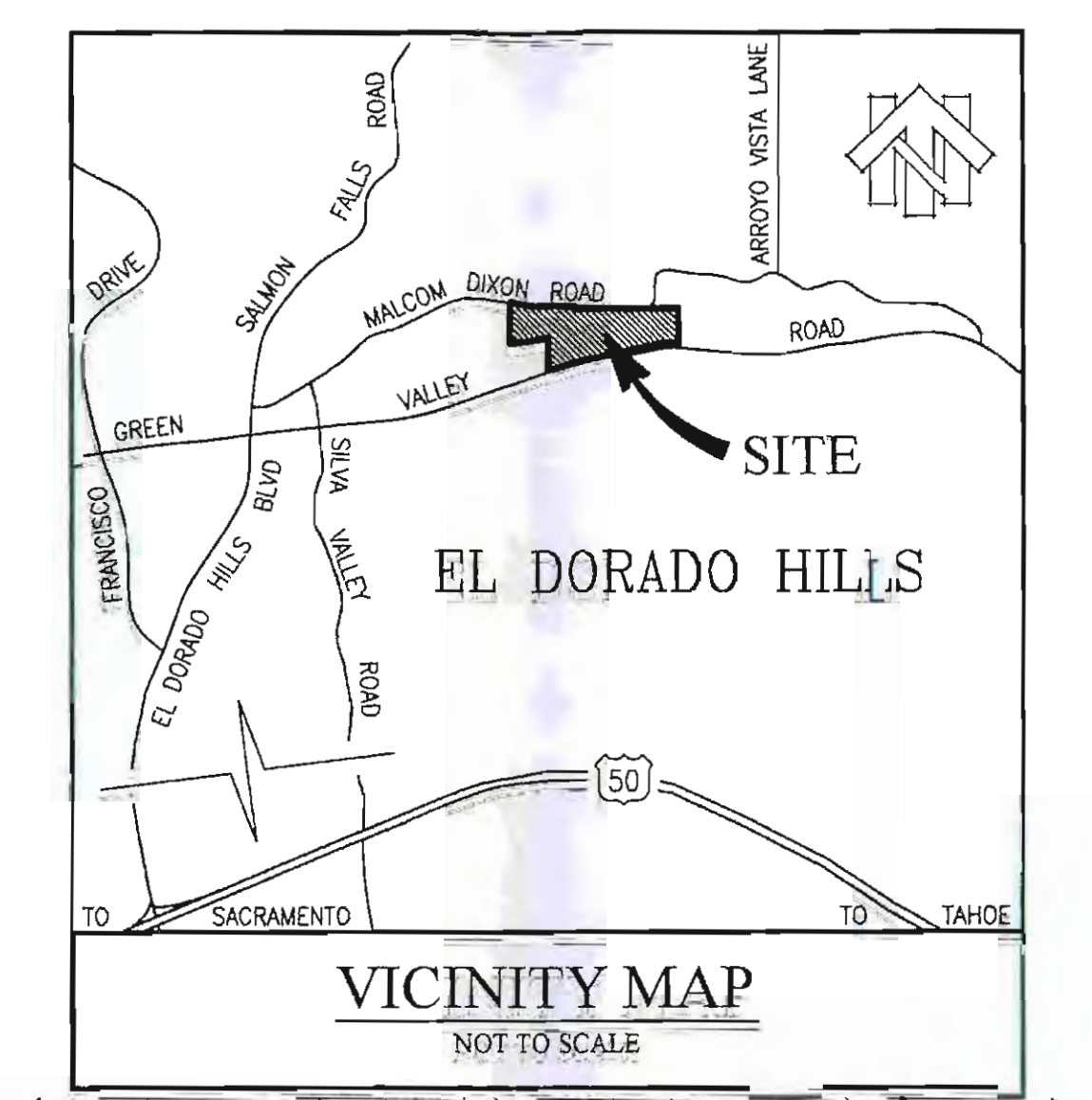

VICINITY MAP
NOT TO SCALE

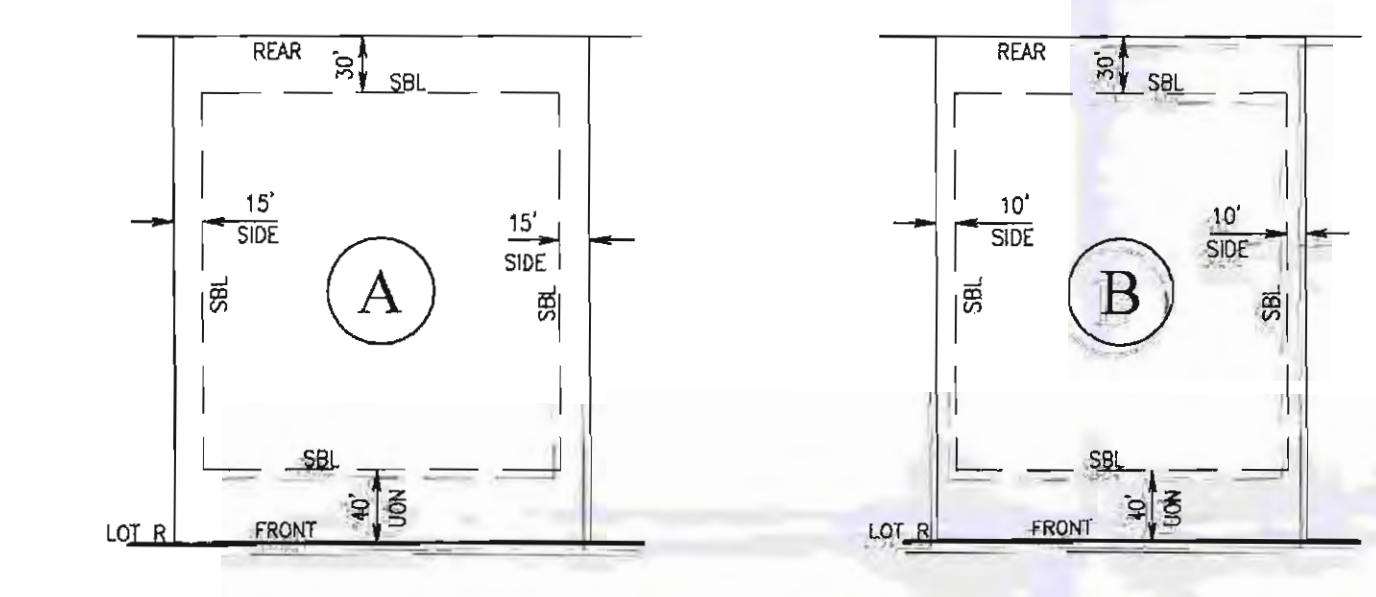

TYPICAL BUILDING SETBACKS
ONE-FAMILY RESIDENTIAL
UNLESS OTHERWISE NOTED (UON) ON TENTATIVE MAP

LEGEND:

- (P) FIRE HYDRANT
- (P) SUBDIVISION BOUNDARY
- (P) RIGHT OF WAY LINE
- (P) LOT LINE
- (P) LOT R WIDTH

PLANNING COMMISSION: _____
APPROVAL/DENIAL DATE: _____

BOARD OF SUPERVISORS: _____
APPROVAL/DENIAL DATE: _____

DATE: August 13, 2014
BY: [Signature]
EXECUTIVE SECRETARY

DAVIS R. CROSARIOL R.C.E. 34520
DATE: 8.18.14



EL DORADO COUNTY SURVEYOR