

CHEFS TOYS

A TriMark Company

Quote

09/27/2023

To:
El Dorado County

Project:
El Dorado County South Lake Tahoe
Sr Center
3050 Lake Tahoe Blvd
South Lake Tahoe, CA 96150

From:
Chefs' Toys
Allison Pannabecker
Remote
Desk: 916.558.3032
Cell: 916.597.5965
allison.pannabecker@chefstoys.com

Job Reference Number: 73691

This Pricing is in accordance with or better than Sourcewell Contract #063022-SES.

Item	Qty	Description	Sell	Sell Total
1	1 ea	CONVECTION OVEN, GAS Blodgett Model No. DFG-100 DBL Convection Oven, gas, double-deck, standard depth, capacity (5) 18" x 26" pans per compartment, (SSD) solid state digital controls, 2-speed fans, interior light, simultaneous operated doors with glass, stainless steel front, sides & top, 6" stainless steel legs, flue connector, (2) 1/2 HP, 55,000 BTU each, cETL, NSF, CE	\$25,285.00	\$25,285.00
	1 ea	3 year parts, 2 year labor and 2 additional year door warranty (parts only), standard		
	1 ea	Natural gas		
	2 ea	115v/60/1-ph, 6.0 amps, 1/2 hp, 2-wire with ground, NEMA 5-15P (per deck), standard		
	1 ea	SSI-M Top Oven: Solid State infinite control with 60 min. manual timer		
	1 ea	SSI-M Bottom Oven: Solid State infinite control with 60 min. manual timer		
	1 ea	Draft diverter or Draft hood must be selected below		
	1 st	4" low profile plate casters (set)	\$381.00	\$381.00
	1 ea	NOTE: DO NOT deduct cost of standard legs		
	1 ea	Extra racks (each)	\$122.00	\$122.00
	1 ea	Gas manifold	\$177.00	\$177.00
		Estimated Lead Time for Oven: 1-2 weeks to come to our warehouse		
2	1 kt	SAFETY SYSTEM MOVEABLE GAS CONNECTOR	\$195.00	\$195.00

Item	Qty	Description	Sell	Sell Total
		Dormont Manufacturing Model No. 1675KIT48 Packed 1 kt Dormont Blue Hose™ Moveable Gas Connector Kit, 3/4" inside dia., 48" long, covered with stainless steel braid, coated with blue antimicrobial PVC, (1) SnapFast® QD, (1) full port valve, (2) 90° elbows, coiled restraining cable with hardware, 180,000 BTU/hr minimum flow capacity, limited lifetime warranty		
3	1 ea	BLAST CHILLER FREEZER, REACH-IN Advanced Gourmet Model No. TECHFROST E15 Techfrost E15 Blast Chiller/Freezer, reach-in, accommodates (15) full size sheet/baking pans, (4) cycles in standard mode, (2) cycles for chilling to +37°F, (2) cycles for freezing to -40°F, indirect air distribution, moisture preservation system, controller touch pad, stainless steel construction, 208-230v/60/1-ph, 13.6 amps, cETLus, ETL-Sanitation 1 kt TECHFROST-CASTER-KIT Casters, for Techfrost Blast Freezers - Free if Needed Includes Freight to our Store or Direct to you	\$15,339.00	\$15,339.00
4	1 ea	ICE MAKER WITH BIN, CUBE-STYLE Ice-O-Matic Model No. ICEU220HA ICE Series™ Cube Ice Maker, cube-style, undercounter, air-cooled, self-contained condenser, approximately 238 lb/108 kg production/24 hours, 70 lb. built-in bin, half-size cube, cULus, NSF, CE 1 ea 3 yr. parts & labor warranty, standard 1 ea 5 yr. parts on the compressor warranty, standard 1 ea 5 yr. evaporator warranty, standard 1 ea 115v/60/1-ph, 11.6 amps, standard 1 ea IFQ1 Water Filter Manifold, single filter designed for ice makers producing up to 800 lbs. (363.6 Kg.) of ice per day, 1.5 gpm maximum flow rate, IsoNet® scale inhibitor, .5 micron particle reduction, quick connect fittings (water filters must be changed every 180 days (6 months), at a minimum)	\$2,897.00	\$2,897.00
5	1 ea	INSIDE DELIVERY Chefs Toys Model No. 49934 Drop Off Inside - General Large Equipment	\$400.00	\$400.00

Merchandise	\$45,076.00
Tax 8.75%	\$3,944.15
Total	\$49,020.15

Prices Good Until: 10/31/2023

Need to return merchandise? Before returning your items, please read our policy and instructions below.
For items that we regularly stock, unless specified below, Chefs' Toys customers may return items within 30 days of receipt if the items are unused with all original packaging; accessories and parts included. For stocked smallwares,

there is no charge. For stocked equipment, the original charge for freight, and/or delivery fees is non-refundable. Returns requiring Chefs' Toys Fleet Pick-Up may incur additional charges. For special ordered items*, please contact Chefs' Toys as manufacturer terms for returns may vary. Upon approval, Chefs' Toys will credit you for the purchase of the returned item less a 30% restocking fee for smallwares (inclusive of packaging, handling & freight), or a 20% restocking fee for equipment plus freight charges as identified by the Original Freight Charge**. Exceptions may apply if Chefs' Toys made an error in processing your order. Returns made within 30 days will be refunded via original method of payment. Purchases by check will be refunded via check after verification of payment by our bank. Final Sale & Nonreturnable Items: Consignment, Demo, Closeout, Outlet, Clearance, Scratch & Dents, 'Special, Only 1 at this Price', Used Items, Special Order*, 1900, Custom Items, Perishable and Consumable Items (including food and disposables), Products sold in aerosol cans, Products that contain flammable liquid, or Furniture. (*Special Order Items are notated as "Special Order" on product detail or description-Please inquire about special ordered items, as manufacturers' terms for returns may vary.) **In some cases, Chefs' Toys may deduct the shipping costs from your refund amount. Commercial & Home Use Policy: Manufacturer warranties may only cover commercial use for products. Use of items in non-commercial environments may void warranties. The right is reserved to deny a sale or shipment for residential usage; if this occurs, you will be notified as soon as possible. Fees: All balances on special order items, and opening orders, must be paid in full prior to delivery or within 30 days, whichever occurs first. Storage fees will accrue at a 2% rate of the total order cost as indicated on the face of this invoice, per month, if the product has been received by Chefs' Toys and 45 days have lapsed since the originally agreed to delivery date. Delivery & Installation: Installation and delivery are not included unless specified on your order. Basic charges do not include lifting over counters and railings, or removal of appliances being replaced. *If you choose not to have us deliver your equipment, we will not be responsible for any physical damage after it has left our premises.* We gladly give free assistance loading any equipment into your vehicle, but we will *not be responsible for any damage to you, your possessions, or your vehicle during the process.* Inspect all items carefully before leaving our facility. *In the event litigation becomes necessary, the prevailing party shall recover reasonable attorney's fees. Exceptions may apply if Chefs' Toys made an error processing your order. Certain restrictions may apply.*

This Quote shall be subject to TriMark's Terms of Sale
<http://www.trimarkusa.com/SiteMedia/SiteResources/Terms/TriMark-Terms-and-Conditions-of-Sale.pdf> which are incorporated herein by reference and shall govern. The parties specifically agree that no signature shall be required in order for this Quote or its applicable terms and conditions to be deemed legally binding and enforceable on Customer where the intent to be so bound can be inferred (including by acceptance or retention of products or services), notwithstanding contrary requirements under any law.

Acceptance: _____ Date: _____
 Printed Name: _____
 Project Grand Total: \$49,020.15



DFG-100

**Full-Size, Standard Depth
Dual Flow Gas Convection Oven**



OPTIONS AND ACCESSORIES

(AT ADDITIONAL CHARGE)

- **Legs, casters & stands**
 - 6" (152mm) seismic legs
 - 6" (152mm) casters
 - 4" (102mm) low profile casters (double only)
 - 25" (635mm) stainless steel stand w/rack guides
 - 29" (737mm) stainless steel, fully welded open stand with pan supports
- **Gas hose w/quick disconnect restraining device**
 - 48" (1219mm) hose
 - 36" (914mm) hose
- SSI-M - Solid state infinite control w/manual timer
- Stainless steel oven liner
- Extra oven racks
- Stainless steel solid back panel
- Gas manifold (for double sections)
- Prison package (includes security control panel and stainless steel back)
- Flue connector

OPTIONS AND ACCESSORIES

(AT NO ADDITIONAL CHARGE)

- Solid stainless steel doors

Project _____

Item No. _____

Quantity _____

Standard depth baking compartment - accepts five 18" x 26" standard full-size baking pans in left-to-right positions. All data is shown per oven section, unless otherwise indicated.

Refer to operator manual specification chart for listed model names.

EXTERIOR CONSTRUCTION

- Stainless steel front, top, and sides
- Dual pane thermal glass windows encased in stainless steel door frames
- Powder coated door handle with simultaneous door operation
- Triple-mounted pressure lock door design with turnbuckle assembly
- Modular slide out front control panel for easy cleaning
- Solid mineral fiber insulation at top, back, sides and bottom

INTERIOR CONSTRUCTION

- Full angle-iron frame
- Double-sided porcelainized baking compartment liner (14 gauge)
- Aluminized steel combustion chamber
- Dual inlet blower wheel
- Five chrome-plated racks, eleven rack positions with a minimum of 1-5/8" (41mm) spacing

OPERATION

- Dual Flow Gas system combines direct and indirect heat
- Electronic spark ignition control system
- Removable dual tube burners
- Pressure regulator
- Manual gas service cut-off switch located on the front of the control panel
- Air mixers with adjustable air shutters
- Solid state thermostat with temperature control range of 200°F (93°C) to 500°F (260°C)
- Two speed fan motor
- 1/2 horsepower blower motor with automatic thermal overload protection
- Control area cooling fan
- Interior oven lights

STANDARD FEATURES

- SSD - Solid state digital control with LED display, Cook & Hold and Pulse Plus®
- 25" (635mm) adjustable stainless steel legs (for single units)
- 6" (152mm) adjustable stainless steel legs (for double sections)
- Draft diverter or draft hood for venting (select one)
- Three year parts and two year labor warranty
- Five year limited oven door warranty*
- * For all international markets, contact your

** For all international markets, contact your local distributor.*

NOTE: The company reserves the right to make substitutions of components without prior notice



www.blodgett.com

42 Allen Martin Drive, Essex Junction, VT 05452
Phone: (802) 658-6600 | Fax: (802) 864-0183

DFG-100

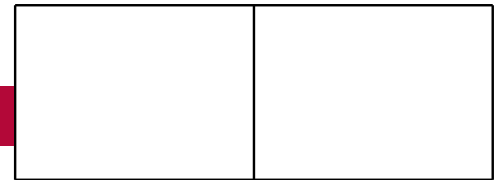
BLODGETT**DFG-100**

APPROVAL/STAMP

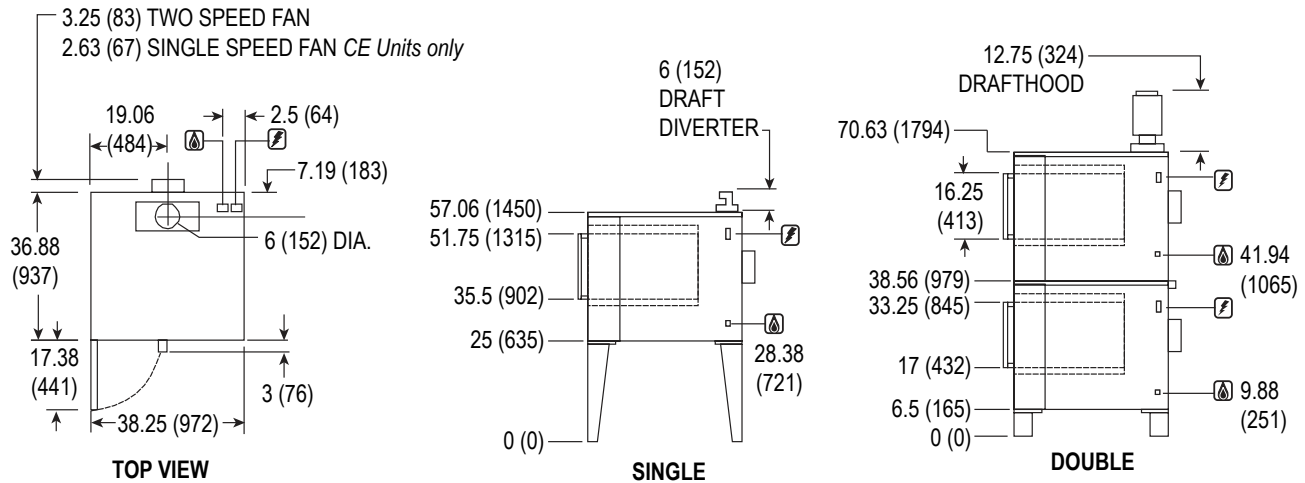

DIMENSIONS ARE IN INCHES (MM)

SHORT FORM SPECIFICATIONS Provide Blodgett full-size convection oven model DFG-100, (single/double) compartment. Each compartment shall have (porcelainized/stainless) steel liner and shall accept five 18" x 26" standard full-size bake pans. Stainless steel front, top and sides. Doors shall be (solid stainless steel/ have dual pane thermal glass windows) with single powder coated handle and simultaneous operation. Unit shall be gas heated with electronic spark ignition and shall cook by means of a dual-flow system combining direct and indirect heat with a gas shutoff switch on the front of the control panel. Air in baking chamber distributed by dual inlet blower wheel powered by a two-speed, 1/2 HP motor with thermal overload protection. Each chamber shall be fitted with two commercial oven lamps, and five chrome-plated removable racks. Control panel shall be recessed with solid state digital control with LED display, Cook & Hold and Pulse Plus. Provide three years parts, two year labor and five year door warranty. Provide options and accessories as indicated.

DIMENSIONS

Floor space	38-1/4" (972mm) W x 36-7/8" (937mm) D
Interior	29" (737mm) W x 20" (508mm) H x 24-1/4" (616mm) D
If oven is on casters	
Single	Add 4-1/2" (114mm) to height
Double	Height dimensions remain the same
Double Low Profile	Subtract 2.5" (64mm) from all height dimensions

PRODUCT CLEARANCE**From combustible and non-combustible construction**

Oven sides	2" (51mm)
Oven back	0" (0mm)

MINIMUM ENTRY CLEARANCE

Uncrated	32-1/16" (814mm)
Crated	37-1/2" (953mm)

SHIPPING INFORMATION**Approx. Weight**

Single	600 lbs. (273 kg)
Double	1295 lbs. (589 kg)

Crate Size

37-1/2" (952mm) x 43-1/2" (1105mm) x 51-3/4" (1315mm)
(2 crates required for double)

GAS SUPPLY (per section)

3/4" NPT

Inlet Pressure

Natural Gas 7.0" W.C. min. - 10.5" W.C. max.
Propane 11.0" W.C. min. - 13.0" W.C. max.

Manifold Pressure

Natural Gas 3.5" W.C.
Propane 10" W.C.

MAXIMUM INPUT

55,000 BTU/hr (16.2 Kw) per oven section

POWER SUPPLY

115 VAC, 1 phase, 6 Amp, 60 Hz., 2-wire with ground, 1/2 H.P., 2 speed motor, 1120 and 1710 RPM
6' (1.8m) electric cord set furnished on 115 VAC ovens only.

Engineering Specification

Job Name _____ Contractor _____
 Job Location _____ Approval _____
 Engineer _____ Contractor's P.O. No. _____
 Approval _____ Representative _____
 SKU _____

SnapFast® Quick-Disconnect Assemblies

Sizes: 1/2" to 1 1/4"

SnapFast Quick-Disconnect Assemblies feature flexible movement and the one-handed quick-disconnect fitting with a unique thermal shut-off design that automatically shuts off the gas when the internal temperature exceeds 350°F (177°C).

Features

SnapFast® One-Handed Quick-Disconnect

- Quick-Disconnect Brass body, aluminum collar
- Thermal Shut-off Shuts off gas when internal temperatures exceed 350°F (177°C)

Additional Components

- Restraining Device PVC coated, steel multi-strand cable and mounting hardware
- Valve Full port, brass body
- Elbow Malleable iron
- *Deluxe Kits Include The Dormont Blue Hose, valve, restraining device, elbows, SnapFast, display box

Specifications

The Dormont Blue Hose®

- Tubing Annealed, 304 stainless steel
- Braiding Multi-strand, stainless steel wire
- Coating Blue antimicrobial PVC, melts at 350°F (177°C); coating will not hold a flame
- End Fittings Carbon steel; zinc trivalent chromate
- Stress Guard® 360° rotational end fitting at both ends

Safety System

The Dormont Safety System™ is the first and only complete gas equipment connection system specifically engineered for the commercial kitchen. The Safety System consists of the famous Dormont Blue Hose and a variety of accessories designed for improved safety and performance in commercial kitchens. Because they are manufactured in the USA under an ISO qualified production process and to multiple design certifications, you can Connect with Confidence with the Dormont Safety System.

NOTICE

The information contained herein is not intended to replace the full product installation and safety information available or the experience of a trained product installer. You are required to thoroughly read all installation instructions and product safety information before beginning the installation of this product.

Dormont product specifications in U.S. customary units and metric are approximate and are provided for reference only. For precise measurements, please contact Dormont Technical Service. Dormont reserves the right to change or modify product design, construction, specifications, or materials without prior notice and without incurring any obligation to make such changes and modifications on Dormont products previously or subsequently sold. Refer to the owner's manual for warranty information.



Approvals & Certifications



NSF/ANSI 169 – Special-purpose food equipment and devices
 ANSI Z21.69 / CSA 6.16 – Connectors for moveable gas appliances
 ANSI Z21.41 / CSA 6.9 – Quick-disconnect devices for use with gas fuel appliances
 ANSI Z21.15 / CSA 9.1 – Manually operated gas valves for appliances, appliance connectors
 Meets requirements of ANSI Z223.1 / NFPA 54 National Fuel Gas Code
 Not for use in temperatures less than 32°F (0°C). For indoor use only.
 Max operating pressure 1/2 psi.
 Refer to the catalog for additional approvals and certifications or go to www.dormont.com.

A restraining device is required for all moveable gas equipment.

SnapFast® Quick-Disconnect Deluxe Kit Assembly

Ordering Information

CONFIGURATION	SIZE I.D.	24" (607MM)	36" (914MM)	48" (1,219MM)	60" (1,524MM)	72" (1,829MM)
Deluxe Kit*	½"	1650KIT24	1650KIT36	1650KIT48	1650KIT60	1650KIT72
Basic Kit**		1650BPQR24	1650BPQR36	1650BPQR48	1650BPQR60	1650BPQR72
Hose Assembly***		1650BPQ24	1650BPQ36	1650BPQ48	1650BPQ60	1650BPQ72
Deluxe Kit*	¾"	1675KIT24	1675KIT36	1675KIT48	1675KIT60	1675KIT72
Basic Kit**		1675BPQR24	1675BPQR36	1675BPQR48	1675BPQR60	1675BPQR72
Hose Assembly***		1675BPQ24	1675BPQ36	1675BPQ48	1675BPQ60	1675BPQ72
Deluxe Kit*	1"	16100KIT24	16100KIT36	16100KIT48	16100KIT60	16100KIT72
Basic Kit**		16100BPQR24	16100BPQR36	16100BPQR48	16100BPQR60	16100BPQR72
Hose Assembly***		16100BPQ24	16100BPQ36	16100BPQ48	16100BPQ60	16100BPQ72
Deluxe Kit*	1¼"	16125KIT24	16125KIT36	16125KIT48	16125KIT60	16125KIT72
Basic Kit**		16125BPQR24	16125BPQR36	16125BPQR48	16125BPQR60	16125BPQR72
Hose Assembly***		16125BPQ24	16125BPQ36	16125BPQ48	16125BPQ60	16125BPQ72

BTU/hr Flow Capacity Natural Gas

(Flow rating BTU/hr 0.64 SP. GR. @ 0.5 inch WC pressure drop)

MODEL	SIZE I.D.	LENGTH				
		24" (607MM)	36" (914MM)	48" (1,219MM)	60" (1,524MM)	72" (1,829MM)
1650BPQ	½"	87,000	77,000	68,000	60,000	55,000
1675BPQ	¾"	232,000	218,000	180,000	158,000	139,000
16100BPQ	1"	414,000	379,000	334,000	294,000	279,000
16125BPQ	1¼"	699,000	615,000	541,000	476,000	419,000

* **Deluxe Kits include:** The Dormont Blue Hose and restraining device, full port valve and (2) street elbows

****Basic Kits include:** The Dormont Blue Hose and restraining device, street elbow and SnapFast

*****Hose Assemblies include:** The Dormont Blue Hose, SnapFast and street elbow

Typical Installation



Options

The Dormont Blue Hose®

The Dormont Blue Hose is a commercial, moveable-grade gas connector designed for use with moveable equipment.

Moveable equipment is defined in ANSI Standard Z21.69/CSA 6.16 as gas utilization equipment that may be mounted on casters or otherwise be subject to movement.



- One-handed quick-disconnect fitting
- Thermal shut-off when internal temperature exceeds 350°F (177°C)



Restraining Device

- ANSI Z21.69 Standard section 1.7.4 states: Connectors when used on caster-mounted equipment shall be installed with a restraining device, which prevents transmission of the strain to the connector

Safety-Set®

Benefits

- Can be used with all caster-mounted equipment including cooking appliances, warming carts, salad bars, and refrigerators
- Crush Resistant
- Resistant to oils and greases
- Open-floor design allows appliance to rest level on the floor to ensure even cooking



Features

- Compatible with 4", 5", and 6" casters
- Certified to NSF/ANSI Standard 169 – Special Purpose Food Equipment & Devices
- Flexible, tough injection molded Thermoplastic Polyurethane (TPU)
- Able to withstand 1,000 PSI of crush pressure

Ordering Instructions:

The Safety-Set wheel positioning product can be ordered individually or with the Blue Hose Kit.

The Safety-Set model name is "PS" and the ordering number is 0241002.

When ordering the Safety-Set with the Blue Hose kit, simply add the letters "PS" to the end of the model number.



We guarantee our commercial gas connectors for the life of the original appliance to which it is connected.

Dormont®

A WATTS Brand

USA: T: (800) 367-6668 • F: (724) 733-4808 • Dormont.com

TECHFROST

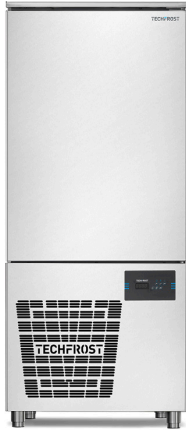

E15



E10



E5



JOF1



JOF23



AG
 ADVANCED GOURMET
 EQUIPMENT & DESIGN
 Exclusive USA Importer and Marketer

555 Birch Creek Rd. McLeansville, NC 27301
 PO Box 116 McLeansville, NC 27301
 PH:336.856.2919

Sales@advancedgourmet.com
 www.advancedgourmet.com

Model: E5

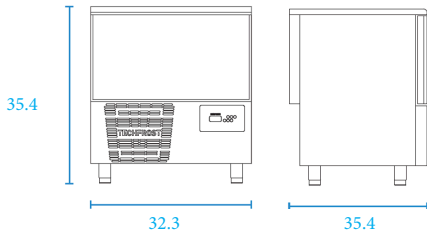

Capacity	5 Cubic Ft. - 5 Full Size Sheet Pans
Performance	Freezing Capacity to -40
Internal Dimensions	27.56"W x 14.76"H x 19.5"D
External Dimensions	32.3"W x 37.4"H x 31.5"D
Electrical Supply	208 - 230V/1Ph/60Hz/7Amps
Refrigerant	R452A
Net Weight	110Kg/242Lbs
Shipping Dims/WGT	40"W x 48"D x 46"H - 317Lbs

VERSATILE	SPACIOUS	DURABLE	APPLICATIONS	APPROVALS
Blast Chiller and Shock Freezer	Holds 5 Full Size Sheet Pans	Easy to clean Stainless Steel	Gastronomy, Pastry, Gelato, Bread	ETL (UL/NSF) Certified

Model: E10

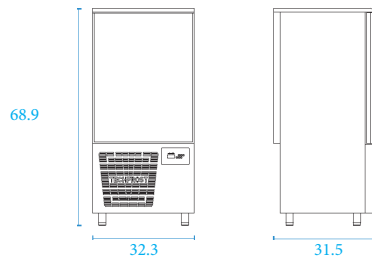

Capacity	12 Cubic Ft. - 10 Full Size Sheet Pans
Performance	Freezing Capacity to -40
Internal Dimensions	27.56"W x 39.37"H x 19.5"D
External Dimensions	32.3"W x 68.9"H x 31.5"D
Electrical Supply	208 - 230V/1Ph/60Hz/8.5Amps
Refrigerant	R452A
Net Weight	190Kg/418Lbs
Shipping Dims/WGT	40"W x 48"D x 78"H - 495 Lbs

VERSATILE	SPACIOUS	DURABLE	APPLICATIONS	APPROVALS
Blast Chiller and Shock Freezer	Holds 10 Full Size Sheet Pans	Easy to clean Stainless Steel	Gastronomy, Pastry, Gelato, Bread	ETL (UL/NSF) Certified

Model: E15

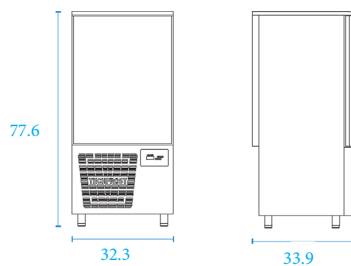

Capacity	13.5 Cubic Ft. - 15 Full Size Sheet Pans
Performance	Freezing Capacity to -40
Internal Dimensions	27.56"W x 43"H x 19.5"D
External Dimensions	32.3"W x 77.6"H x 33.9"D
Electrical Supply	208 - 230V/1Ph/60Hz/13.6Amps
Refrigerant	R452A
Net Weight	225Kg/496Lbs
Shipping Dims/WGT	40"W x 48"D x 86"H - 545 Lbs

VERSATILE	SPACIOUS	DURABLE	APPLICATIONS	APPROVALS
Blast Chiller and Shock Freezer	Holds 15 Full Size Sheet Pans	Easy to clean Stainless Steel	Gastronomy, Pastry, Gelato, Bread	ETL (UL/NSF) Certified



Model: JOF 1

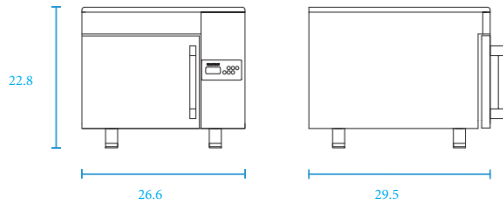

Capacity	3.6 Cubic Ft. - 4 - 1/2 Size Sheet Trays
Performance	Freezing Capacity to -40
Internal Dimensions	16.5"W x 12.8"H x 24"D
External Dimensions	26.4"W x 19.7"H x 29.5"D
Electrical Supply	208 - 230V/1Ph/60Hz/5Amps
Refrigerant	R404A
Net Weight	68Kg/105Lbs
Shipping Dims/WGT	40"W x 48"D x 31"H - 288 Lbs

VERSATILE	SPACIOUS	DURABLE	APPLICATIONS	APPROVALS
Blast Chiller and Shock Freezer	Holds 4 - 1/2 Size Sheet Pans	Easy to clean Stainless Steel	Gastronomy, Pastry, Gelato, Bread	ETL (UL/NSF) Certified

Model: JOF 23

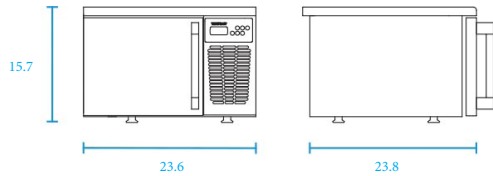

Capacity	1.5 Cubic Ft. - 3 - 1/4 Size Sheet Trays
Performance	Freezing Capacity to -40
Internal Dimensions	13.39"W x 10.63"H x 14.17"D
External Dimensions	23.62"W x 15.35"H x 23.62"D
Electrical Supply	115-120V/1Ph/60Hz/4 Amps
Refrigerant	R404A
Net Weight	48Kg/106Lbs
Shipping Dims/WGT	40"W x 48"D x 31"H - 180Lbs

VERSATILE	SPACIOUS	DURABLE	APPLICATIONS	APPROVALS
Blast Chiller and Shock Freezer	Holds 4 - 1/4 Size Sheet Pans	Easy to clean Stainless Steel	Gastronomy, Pastry, Gelato, Bread	ETL (UL/NSF) Certified

Electrical and Refrigerant

JOF23	JOF1	E5	E10	E15
115-120V/60Hz/4A/ 880 Watts, 257.8 Btu	208-230V/60Hz/5A 1100 Watts/322.3 Btu	208-230V/1Ph/60Hz/1kW 1570 Watts/451.2 Btu Running Amps: 7A Suggested Breaker: 20A	208-230V/1Ph/60Hz/2.4kW 1870 Watts/547.9 Btu Running Amps: 8.5A Suggested Breaker: 20A	208-230V/1Ph/60Hz/2.55kW 2992 Watts/876.6 Btu Running Amps: 13.6A Suggested Breaker: 20A
Low side pressure 200 PSI High side pressure 377 PSI	Low side pressure 200 PSI High side pressure 377 PSI	Low side pressure 200 PSI High side pressure 377 PSI	Low side pressure 200 PSI High side pressure 377 PSI	Low side pressure 200 PSI High side pressure 377 PSI

Unique Features:

- Stainless steel construction - Faster chilling times - Small footprint -Energy efficient
- Four cycles in standard mode - Moisture prevention system
- Smudge resistant touch pad





TECHFROST

Marketing and Distributions by **AG** ADVANCED GOURMET
EQUIPMENT & DESIGN



555 Birch Creek Rd. McLeansville, NC 27301
PO Box 116 McLeansville, NC 27301
PH:336.856.2919

Sales@advancedgourmet.com
www.advancedgourmet.com



ICEU220/226/225 - SELF CONTAINED CUBE ICE MAKER

Ice-O-Matic
Ice. Pure and Simple



ICEU220

Features

- Space-saving 24" (623 mm) wide undercounter design.
- Produces up to 251 lbs (114 kg) of ice per day.
- *Harvest Assist* provides consistent ice production for the life of the ice maker while reducing energy consumption and increasing capacity.
- *Pure Ice*® exclusively by Ice-O-Matic. Built-in antimicrobial protection for the life of the ice maker inhibits bacteria growth on ice maker surfaces. Ice-O-Matic's optional water filtration system provides protection against unpleasant tastes, odors and scale formation.
- Durable, electroless nickel plating on all evaporator plates ensures reliability.
- *Longest warranty in the industry.* Purchase an Ice-O-Matic water filter with your cube ice maker, replace the filter every six months, and the evaporator warranty is extended to 7 years parts and labor (available in the U.S. and Canada only).
- Constructed from corrosion-resistant stainless steel and fingerprint-proof plastic.

Options & Accessories

Ice Machine Model	WATER FILTERS		
	Manifold		Inline
	System	Replacement	System
ICEU220	IFQ1	IOMQ (I)	IFI4C / IFI8C
ICEU226			
ICEU225			

Ice Maker Warranty

Every Ice-O-Matic ice maker is backed by a warranty that provides both parts and labor coverage.

- Three years **Parts** and **Labor**.
- Five years **Parts** coverage on the evaporator and compressor.
- Seven years **Parts** and **Labor** on the evaporator when you purchase an Ice-O-Matic water filter with your cube ice maker and replace the filter every six months (available in the U.S. and Canada only).

Ice Form



CUBE

FULL CUBE DIMENSIONS	
W x D x H (in.)	7 $\frac{1}{8}$ x 7 $\frac{1}{8}$ x 7 $\frac{1}{8}$
W x D x H (mm)	22 x 22 x 22
HALF CUBE DIMENSIONS	
W x D x H (in.)	3 $\frac{1}{8}$ x 7 $\frac{1}{8}$ x 7 $\frac{1}{8}$
W x D x H (mm)	10 x 22 x 22

Space-Saving Solutions

- Front air discharge design for compact spaces.
- Low profile top saves counter space.
- Stores up to 74 lbs (33.5 kg) of ice.
- Easy front access to ice.
- Available with an air-cooled or water-cooled condenser.

ICEU220/226/225 SELF CONTAINED CUBE ICE MAKER





ICEU220/226/225 - SELF CONTAINED CUBE ICE MAKER



ICEU220/226/225 SELF CONTAINED CUBE ICE MAKER

Air and Water Cooled

- A. Ice maker water in, 3/8" FPT.
- B. Bin and ice maker drain, 3/4" FPT.
- C. Hole for electrical connections, 7/8" (Cord on 115V).
- D. Condenser water in, 3/8" FPT (water cooled units only).
- E. Condenser water out, 1/2" FPT (water cooled units only).

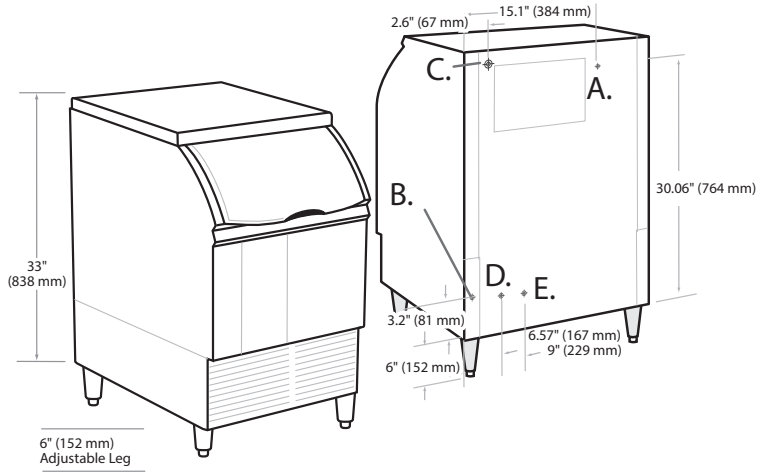
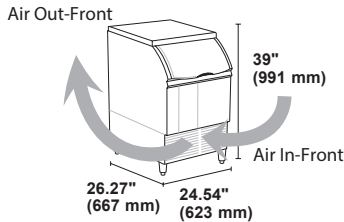

Front & Rear View

Operating Requirements

	MINIMUM	MAXIMUM	
		60 Hz	50 Hz
Ambient Temp. Range Air	50°F (10°C)	100°F (38°C)	110°F (43°C)
Water Temp.	40°F (4.4°C)		
Water Pressure	20 PSIG (1.4 BAR)	60 PSIG (4.1 BAR)	

Dimensions

ALL MODELS	
W x D x H (in.)	24.54 x 26.27 x 39
W x D x H (mm)	623 x 667 x 991

Specifications

Model Number	Cond. Unit	Ice Production per 24hrs		Water Usage gallons per 100 lbs of Ice 90°F air/70°F water		kWH Used per 100 lbs of ice @ 90°F air/70°F water	Voltage Characteristics	Min. Circuit Ampacity	Max Breaker Size	Approx. BTUs per hour**	
		70°F air/50°F water lbs (kg)	90°F air/70°F water lbs (kg)	Potable	Condenser						
ICEU220A*	Air	238 (108)	165 (74)	25.0	N/A	7.4	115/60/1	11.9	15	5,000	
ICEU220W*	Water	251 (114)	193 (88)		193	5.6		8.9			
ICEU226A	Air	241 (109)	166 (75)		N/A	8.0	208-230/60/1	6.0	15		
ICEU226W	Water	232 (105)	159 (72)		179	6.1		4.1			
ICEU225A	Air	211 (96)	143 (65)		N/A	8.8	208-230/60/1	4.9	16		4,000
ICEU225W	Water	210 (95)	174 (79)		156	6.3		4.4			

**BTUH is calculated 0°F Evaporator, 100°F Condensing, and 33 PSIG.

NOTES:
 Number of Wires: 3 (including ground)
 Approx. Shipping Weight lbs (kg): ICEU220A 160 (73) • ICEU220W 160 (73) • ICEU226A 160 (73) • ICEU226W 160 (73) • ICEU225A 160 (73) • ICEU225W 160 (73)
 Refrigerant Type: ICEU225A = R404A
 *Cordset included with 115V units.



Ice-O-Matic
Ice. Pure and Simple

WATER FILTERS

IFQ1-S SYSTEM



10.4" H x 6" W x 4" D
(264 mm x 152 mm x 102 mm)

Single Cartridge with a
Quick Disconnect

IFQ1 SYSTEM



15" H x 6" W x 4" D
(381 mm x 152 mm x 102 mm)

Single Cartridge with a
Quick Disconnect

IFQ2 SYSTEM



16" H x 10" W x 7.125" D
(406 mm x 254 mm x 181 mm)

Dual Cartridge with a
Quick Disconnect

IFQ1-XL SYSTEM



21" H x 6" W x 4" D
(533 mm x 152 mm x 102 mm)

Single Cartridge with a
Quick Disconnect

IFQ2-XL SYSTEM



23.21" H x 13" W x 4.65" D
(590 mm x 330 mm x 118 mm)

Dual Cartridge with a
Quick Disconnect

IF14C & IF18C SYSTEMS



11.75" H x 2.75" W
(299 mm x 57 mm)

Filter supplied with 1/4" or 3/8"
(6 or 8 mm) compression

ICE MAKING CAPACITY: Up to 600 lbs. (272 kg)
Ideal for limited-space and undercounter applications

REPLACEMENT FILTER CARTRIDGES



Snapshot

IFQ Series water treatment systems reduce sediment down to 1/2 micron and reduce chlorine, taste and odor at a flow rate of up to 3.0. The systems include IsoNet®, which delivers consistent protection against the precipitation and accumulation of scale and provides a protective barrier to help guard against corrosion.

Features and Benefits

- Reduces maintenance frequency and cost, and extends equipment life.
- Improves equipment operating efficiency
- Incorporates IsoNet - patented scale-inhibiting technology.
- Gradient-density depth filtration reduces dirt, rust and other debris as small as 1/2 micron to ensure clean, clear ice and protect solenoids, valves and other fittings against wear and plugging.
- High-capacity activated carbon filtration reduces taste and odor and protects equipment against corrosive chlorine.
- 1/4 turn QT "Quick-Twist" cartridge makes changing the filter quick, easy and sanitary.
- Wall-mount bracket and full-flow inlet shut-off valve make installation simple.
- Certifies to NSF Standard 42

All filter systems include:

Filter cartridge with FDA approved scale inhibitor, inlet shut-off valve, gauge and quick-connect fittings.

IOMQ replacement cartridges for use with IFQ1 & IFQ2 manifold filter systems. IOMQ-XL replacement cartridge for use with IFQ1-XL manifold filter system.



WATER FILTERS

IFQ SERIES FILTER SYSTEM							
Model Number	Description	Service Flow Rate Max. gpm (lpm)	Capacity Gal (L)	Operating Pressure Range Psi (bar)	Inlet Water Temp Range °F (°C)	Micron Rating	Approx. Shipping Weight lbs (kg)
IFQ1-S	Single Filter	.75 (2.84)	6,000 (22,712)	10 - 125 (0.7 - 8.6)	35 - 100 (1.7 - 38)	.5	2 (.91)
IFQ1	Single Filter	1.5 (5.68)	15,000 (56,775)				3 (1.3)
IFQ1-XL	Single Filter	2.25 (8.5)	22,500 (85,162)				5 (2.3)
IFQ2	Dual Filter	3.0 (11.4)	30,000 (113,550)				7 (3.2)
IFQ2-XL	Dual Filter	4.5 (17)	45,000 (170,344)				9 (4.1)

SINGLE INLINE FILTER CARTRIDGES						
Model Number	Description	Service Flow Rate Max. gpm (lpm)	Operating Pressure Range Psi (bar)	Inlet Water Temp Range °F (°C)	Micron Rating	Approx. Shipping Weight lbs (kg)
IF14C	Single Inline Cartridge 1/4" (6.35mm) compression	1.0 (3.79)	10 - 100 (.07 - 6.9)	35 - 100 (2 - 38)	10	2 (1)
IF18C	Single Inline Cartridge 3/8" (9.53mm) compression					

		WATER FILTERS					
		IFQ1-S	IFQ1	IFQ1-XL	IFQ2	IFQ2-XL	IF14C IF18C
CUBE ICE	ICEU070	X					X
	ICEU150 - ICEU220 - ICEU300	X					X
	CIMO320 - CIMO430		X				
	CIMO520 - CIMO630			X			
	CIMO826 - CIM1136				X		
	CIM1446 - CIM1545				X		
	CIM1845 - CIM2046					X	
	ICE1506 - MODULAR				X		
FLAKE ICE	UCG060 - UCG130*	X					X
	MF10500	X					X
	MF10800 - MF11256			X			
	MF11506				X		
PEARL ICE	MF12306					X	
	GEMU090	X					X
	GEMO450 - GEMO650		X				
	GEMO956			X			
	GEM1306				X		
	GEM2006					X	

* Gourmet Ice

Installation Tips

Feed-water connection to system should be COLD only.

Do not exceed system specifications for temperature and pressure.

Allow 3" clearance below system for cartridge removal and replacement.

Connect filtered water line to ice connections only. Do not use for condenser water.

No activation procedure or flushing is required for system to perform as specified.

Extended Warranty Program

- Buy a new Ice-O-Matic Water Filter System with a new CIM Series™ Cube ice maker, replace the filter cartridge every 6 months, and Ice-O-Matic will extend the limited cuber evaporator warranty to 7 years parts and labor (U.S. and Canada only).
- New ice maker and filter must be installed at the same time.
- Ice maker and water filter must be registered with Ice-O-Matic within 10 days of installation. Register ice maker and filter at iceomatic.com/warranty.
- Water filters must be changed every 180 days (6 months), at a minimum. All changes must be registered with Ice-O-Matic and include the water filter's model and serial numbers. Register water filter changes at www.iceomatic.com.
- Program is available with all Ice-O-Matic IFQ1-S, IFQ1, IFQ1-XL, IFQ2, IFQ2-XL, IF14C or IF18C water filter systems.
- Replacement filter must be Ice-O-Matic models.