

S17-0016/AT&T CAF4
Site 3 Pleasant Valley
Location Map
Exhibit A

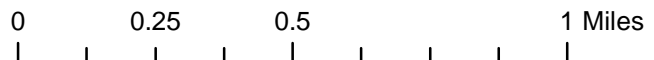

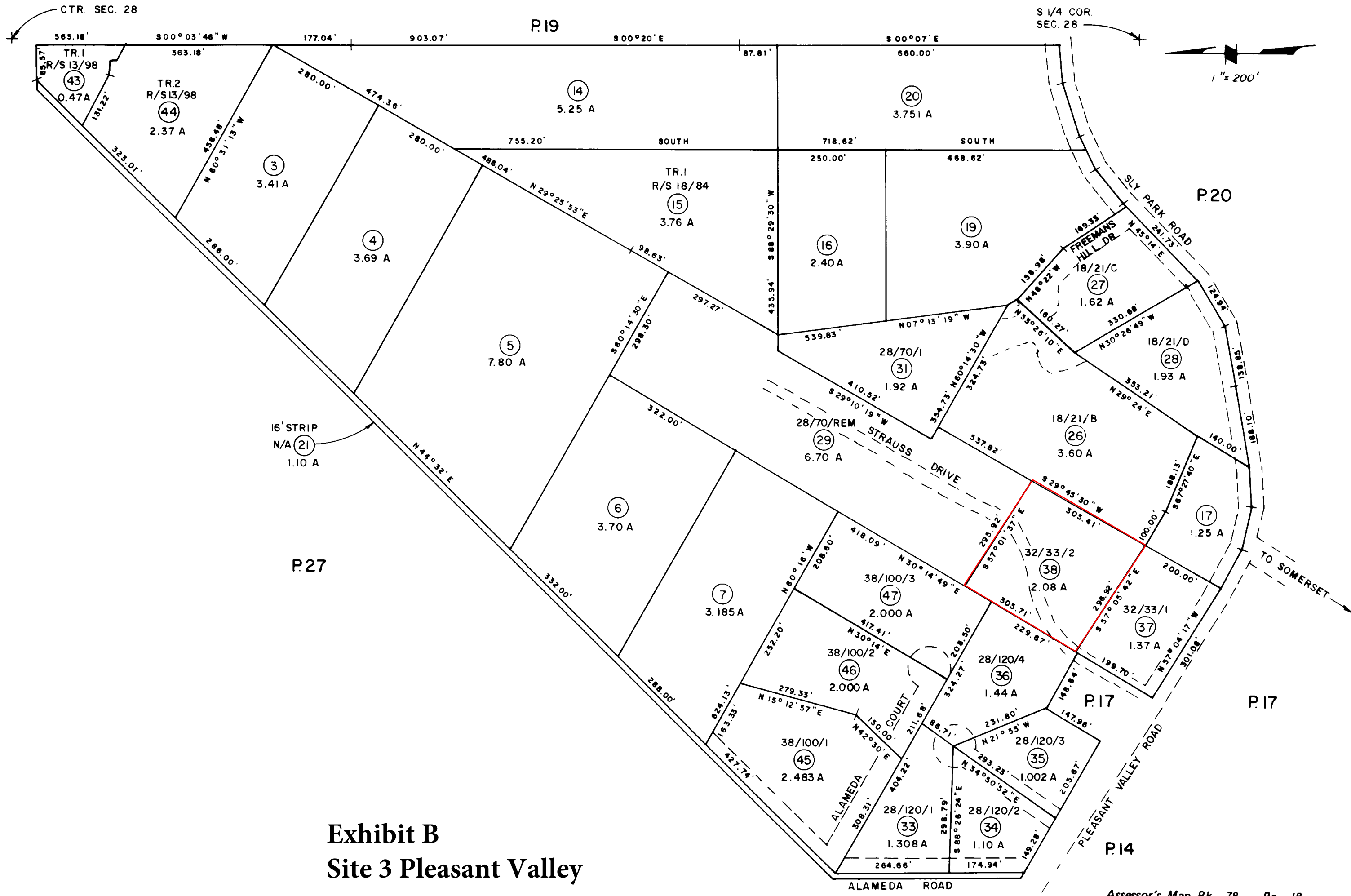
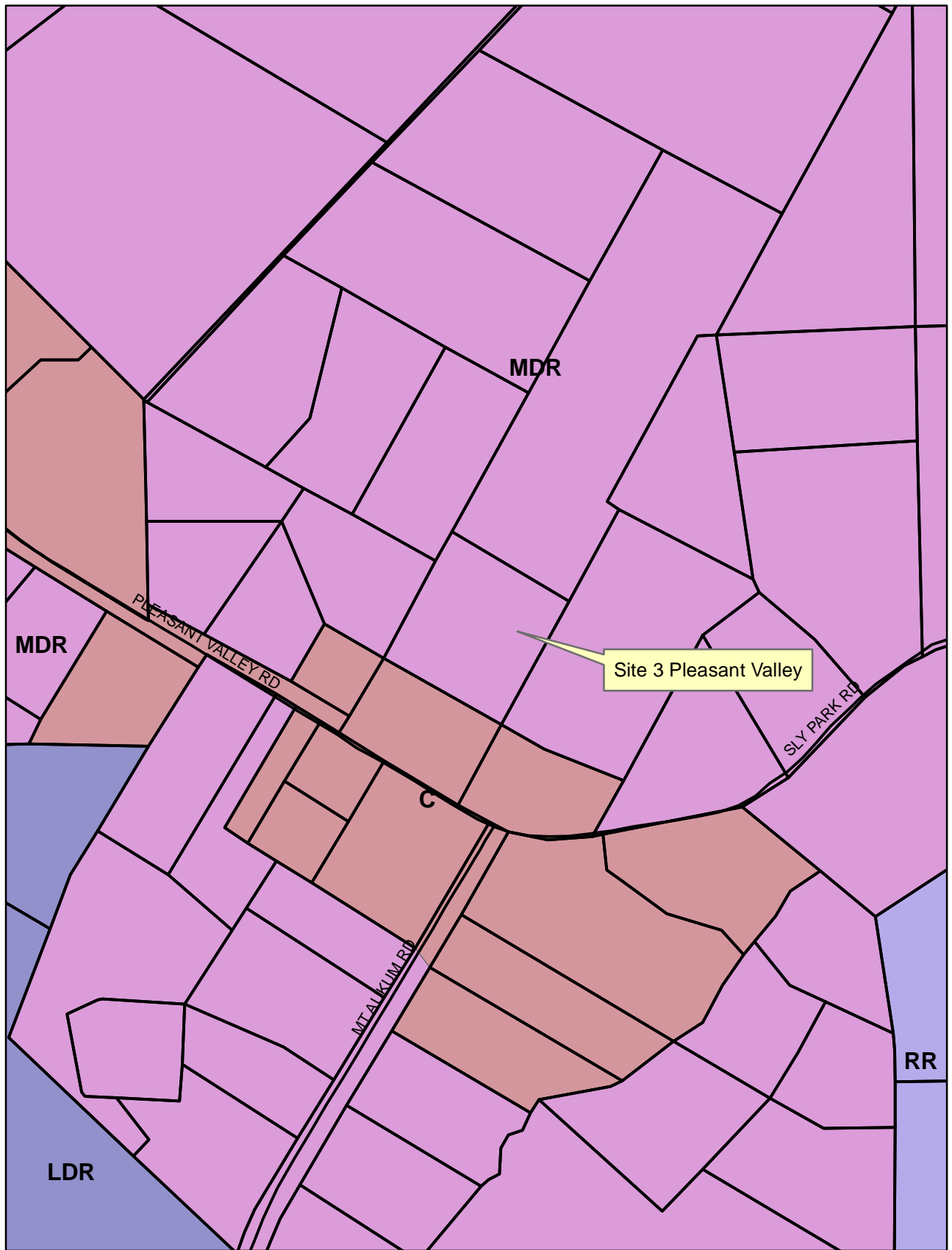

Exhibit B Site 3 Pleasant Valley

THIS MAP IS NOT A SURVEY, It is prepared by the El Dorado Co. Assessor's office for assessment purposes only.

NOTE - Assessor's Block Numbers Shown in Ellipses
Assessor's Parcel Numbers Shown in Circles



S17-0016/AT&T CAF4
 Site 3 Pleasant Valley
 General Plan Map
 Exhibit C

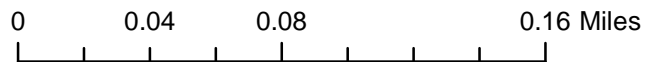

- C
- LDR
- MDR
- RR

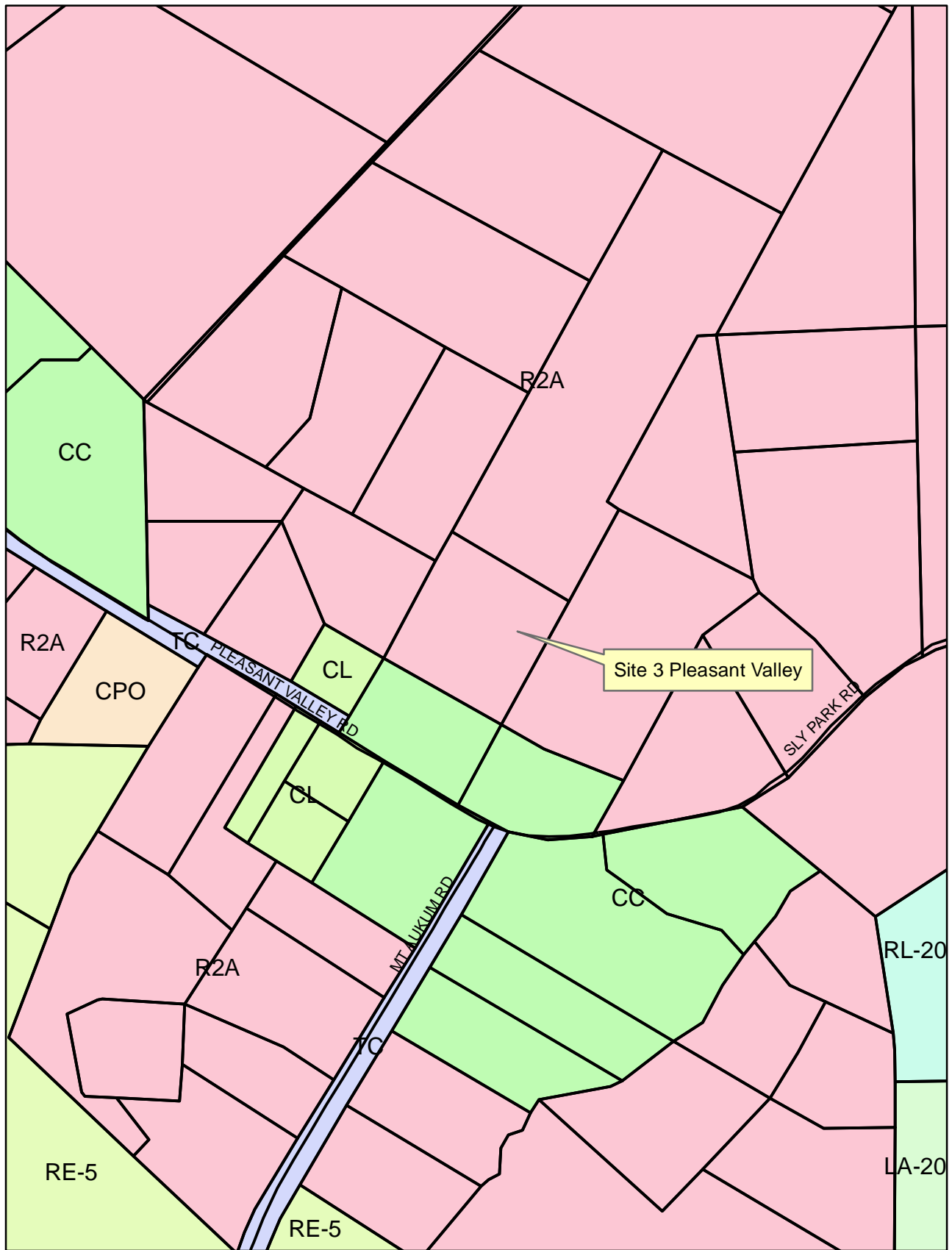

- CC
- CL
- CPO
- LA-20
- R2A
- RE-5
- RL-20
- TC

S17-0016/AT&T CAF4
Site 3 Pleasant Valley
Zoning Map
Exhibit D

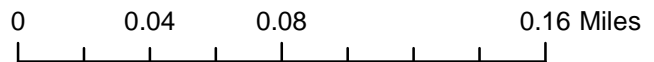



S17-0016/AT&T CAF4
Site 3 Pleasant Valley
Aerial Map
Exhibit E

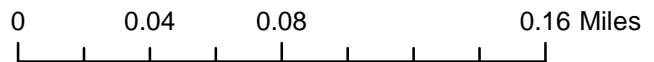

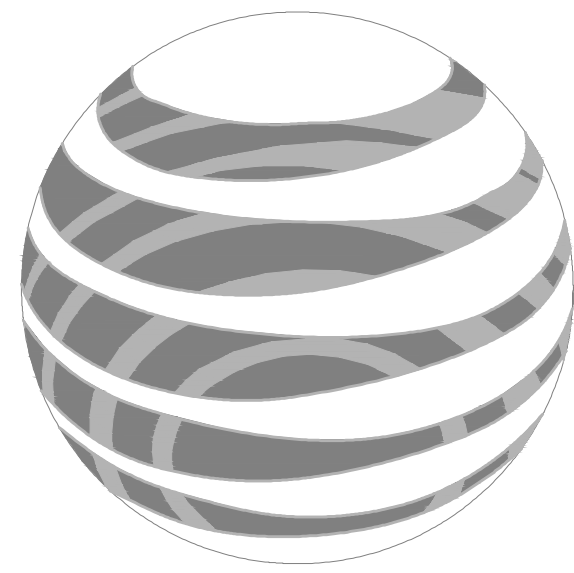

at&t

SITE NUMBER: CVL03180

SITE NAME: PLEASANT VALLEY

4559 STRAUSS DRIVE
PLACERVILLE, CA 95667
JURISDICTION: ELDORADO COUNTY

SITE TYPE: MONOPINE/SHELTER

Issued For:
PLEASANT VALLEY
4559 STRAUSS DRIVE
PLACERVILLE, CA 95667

PREPARED FOR
 at&t
2600 Camino Ramon, 4W850 N
San Ramon, California 94583

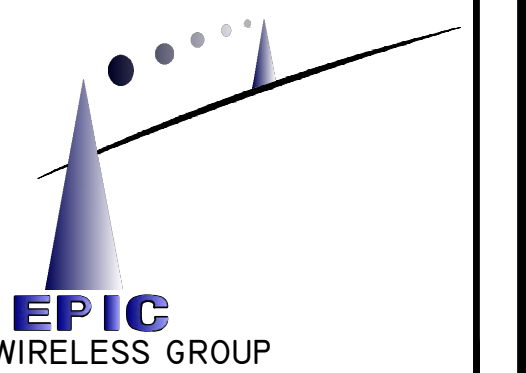

AT&T SITE NO: CVL03180
PROJECT NO: 13787610
DRAWN BY: CES
CHECKED BY: CES

REV	DATE	DESCRIPTION
0	07/05/17	ZD 90%
1	08/03/17	ZD 100% SHELTER CHANGE

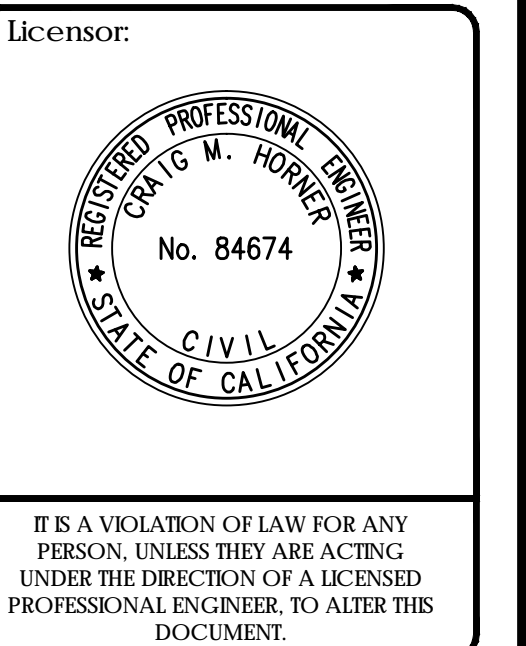

Engineer:
ADAPTIVE RE-USE ENGINEERING
Craig Horner, PE 84674
214-407-3184
3112 LEATHA WAY
SACRAMENTO, CA 95821
craigmhorner@yahoo.com

SHEET TITLE:
TITLE SHEET
SHEET NUMBER:
T-1

PROJECT DESCRIPTION	PROJECT INFORMATION	PROJECT TEAM	SHEET INDEX	REV																												
<p>NEW SITE BUILD UNMANNED TELECOMMUNICATIONS FACILITY.</p> <ol style="list-style-type: none"> BRING POWER / TELCO / FIBER TO SITE LOCATION GRAVEL ROAD IMPROVEMENT FROM ROW 40'X45' FENCED LEASE AREA INSTALL AT&T APPROVED PRE-MANUFACTURED EQUIPMENT SHELTER AND ASSOCIATED INTERIOR EQUIPMENT ADD (1) NEW GPS UNITS ADD 160'-0" MONOPINE ADD (12) ANTENNAS (4) PER ALPHA, BETA, GAMMA SECTOR ADD (21) RRS ADD (4) SURGE SUPPRESSORS ADD (2) FUTURE 4' MICROWAVE DISHES ADD 6'-0" HIGH CHAIN LINK FENCE W/ VYNAL SLATS ADD 35KW LP PROPANE GENERATOR ADD 500 GAL LP PROPANE STORAGE TANK 	<p>PROPERTY INFORMATION: SITE NAME: PLEASANT VALLEY SITE NUMBER: CVL03180</p> <p>SEARCH RING: PLEASANT VALLEY FA# 13787610 SITE ADDRESS: 4559 STRAUSS DRIVE PLACERVILLE, CA 95667</p> <p>A.P.N. NUMBER: 078-180-38-100</p> <p>CURRENT USE: SINGLE FAMILY RESIDENTIAL, RURAL RESEDENTIAL</p> <p>PROPOSED USE: (U) UNMANNED TELECOMMUNICATION FACILITY</p> <p>JURISDICTION: ELDORADO COUNTY</p> <p>LATITUDE: N 38° 41' 02.92"</p> <p>LONGITUDE: W 120° 39' 43.12"</p> <p>GROUND ELEVATION: ±2497.0 FT. AMSL</p>	<p>PROPERTY OWNER: VINCENT & JO ANNE GLOWCZWSKIE 4559 STRAUSS DRIVE PLEASANT VALLEY, CA 95667</p> <p>POWER AGENCY: PG&E PG&E CORPORATION 1 MARKET STREET, SPEAR TOWER SAN FRANCISCO, CA 94105 PH: 1-800-743-5000</p> <p>TELEPHONE AGENCY: AT&T 525 MARKET STREET, SPEAR TOWER SAN FRANCISCO, CA 94105 PH: 1-800-310-2355</p> <p>RFDS DATED 05-16-2017, ISSUE 1.0 REVISION 1.00.01</p>	<p>APPLICANT / LESSEE: AT&T 5001 EXECUTIVE PARKWAY SAN RAMON, CA 945834</p> <p>RF ENGINEER: AT&T CONTACT: MUHAMMAD AHMED EMAIL: MA912P@ATT.COM</p> <p>PROJECT MGR.: EPIC WIRELESS CONTACT: NICK TAGAS EMAIL: NICK.TAGAS@EPICWIRELESS.NET PH: (916) 990-1446</p> <p>SITE ACQUISITION: COMPANY: EPIC WIRELESS CONTACT: JARED KEARSLEY (ZONING MGR.) EMAIL: JARED.KEARSLEY@EPICWIRELESS.NET CELL: (916) 755-1326</p> <p>CONSTRUCTION MGR.: COMPANY: EPIC WIRELESS CONTACT: PETE MANAS EMAIL: PETE.MANAS@EPICWIRELESS.NET PH: (530) 383-5957</p>	<p>A&E DESIGN GROUP: COMPANY: EPIC WIRELESS CONTACT: CARL SYLVESTER CARL.SYLVESTER@EPICWIRELESS.NET PH: (530) 933-2763</p> <p>ARCHITECT / ENGINEER: ADAPTIVE RE-USE ENGINEERING CONTACT: CRAIG HORNER, PE 84674 EMAIL: CRAIGMHORNER@YAHOO.COM PH: (214) 407-3184</p> <p>CIVIL VENDOR: VINCOLLUMS CM CONTACT: KEN ABEL EMAIL: KABEL@VINCOLLUMS.COM PH: (916) 844-4602</p>	<p>T-1 TITLE SHEET GN-1 GENERAL NOTES C-1 SITE SURVEY (BY OTHERS) FOR REFERENCE ONLY C-2 SITE SURVEY (BY OTHERS) FOR REFERENCE ONLY C-2.1 EROSION CONTROL NOTES C-2.2 GRADING PLAN & DETAILS A-1 OVERALL SITE PLAN - EXTERIOR EQUIPMENT SHELTER A-1.1 SITE PLAN - EXTERIOR EQUIPMENT SHELTER A-2 EQUIPMENT AREA PLAN - EXTERIOR EQUIPMENT SHELTER A-3 ANTENNA PLAN & DETAILS - MONOPINE A-4.1 PROPOSED MONOPINE NORTH - SOUTH ELEVATION A-4.2 PROPOSED MONOPINE WEST - EAST ELEVATION</p>																											
<p>CODE COMPLIANCE</p> <p>ALL WORK AND MATERIALS SHALL BE PERFORMED AND INSTALLED IN ACCORDANCE WITH THE CURRENT EDITIONS OF THE FOLLOWING CODES AS ADOPTED BY THE LOCAL GOVERNING AUTHORITIES. NOTHING IN THESE PLANS IS TO BE CONSTRUCTED TO PERMIT WORK NOT CONFORMING TO THESE CODES:</p> <ol style="list-style-type: none"> 2016 CALIFORNIA ADMINISTRATIVE CODE, PART 1, TITLE 24, C.C.R. (CALIFORNIA CODE OF REGULATIONS) 2016 CALIFORNIA BUILDING CODE (CBC), PART 2, TITLE 24, C.C.R. (VOLUMES 1 & 2), (2015 INTERNATIONAL BUILDING CODE) 2016 CALIFORNIA ELECTRICAL CODE (CEC), PART 3, TITLE 24, C.C.R., (2014 NATIONAL ELECTRICAL CODE) 2016 CALIFORNIA MECHANICAL CODE (CMC), PART 4, TITLE 24, C.C.R., (2015 UNIFORM MECHANICAL CODE) 2016 CALIFORNIA PLUMBING CODE (CPC), PART 5, TITLE 24, C.C.R., (2015 UNIFORM PLUMBING CODE) 2016 CALIFORNIA ENERGY CODE (CEC), PART 6, TITLE 24, C.C.R. 2016 CALIFORNIA HISTORICAL BUILDING CODE, PART 8, TITLE 24, C.C.R., (2015 INTERNATIONAL BUILDING CODE) 2016 CALIFORNIA FIRE CODE, PART 9, TITLE 24 C.C.R., (2015 INTERNATIONAL FIRE CODE) 2016 CALIFORNIA EXISTING BUILDING CODE, PART 10, TITLE 24, C.C.R., (2015 INTERNATIONAL BUILDING CODE) 2016 CALIFORNIA GREEN BUILDING STANDARDS CODE, PART 11, TITLE 24 C.C.R., (CALGreen) 2016 CALIFORNIA REFERENCED STANDARDS, PART 12, TITLE 24 C.C.R. ANSI/EIA-TIA-222-G ALONG WITH ANY OTHER APPLICABLE LOCAL & STATE LAWS AND REGULATIONS. <p>DISABLED ACCESS REQUIREMENTS THIS FACILITY IS UNMANNED & NOT FOR HUMAN HABITATION. DISABLED ACCESS & REQUIREMENTS ARE NOT REQUIRED IN ACCORDANCE WITH CALIFORNIA STATE BUILDING CODE TITLE 24 PART 2, SECTION 11B-203.4</p>	<p>VICINITY MAP</p>	<p>DIRECTIONS FROM AT&T</p> <p>DIRECTIONS FROM AT&T'S OFFICE AT 2600 CAMINO RAMON, SAN RAMON, CA 2600 CAMINO RAMON SAN RAMON, CA 94583</p> <ol style="list-style-type: none"> GET ON I-680 S 3 MIN (1.1 MI) HEAD SOUTHEAST ON CAMINO RAMON TOWARD BISHOP DR 0.3 MI TURN RIGHT ONTO BOLLINGER CANYON RD 0.5 MI USE THE RIGHT LANE TO MERGE ONTO I-680 S VIA THE RAMP TO SAN JOSE 0.3 MI TAKE I-580 E, I-205 E, I-5 N AND CA-88 E TO CA-124 N IN AMADOR COUNTY 1 H 27 MIN (87.5 MI) MERGE ONTO I-680 S 3.9 MI USE THE RIGHT 2 LANES TO TAKE EXIT 30B TO MERGE ONTO I-580 E TOWARD STOCKTON 20.5 MI KEEP LEFT TO CONTINUE ON I-205 E, FOLLOW SIGNS FOR INTERSTATE 205/TRACY/STOCKTON 14.5 MI MERGE ONTO I-5 N 12.3 MI USE THE RIGHT LANE TO TAKE THE CA-4 E EXIT TOWARD DOWNTOWN STOCKTON 0.7 MI KEEP LEFT AND MERGE ONTO CA-4 2.7 MI USE THE LEFT 2 LANES TO TAKE EXIT 68B TO MERGE ONTO CA-99 N TOWARD SACRAMENTO 1.8 MI TAKE EXIT 255 FOR CA-88 E/WATERLOO ROAD TOWARD JACKSON 0.2 MI TURN RIGHT ONTO CA-88 E (SIGNS FOR JACKSON/WATERLOO ROAD) 19.1 MI TURN LEFT TO STAY ON CA-88 E 11.7 MI CONTINUE ON CA-124 N TO CA-16 E 12 MIN (10.5 MI) TURN LEFT ONTO CA-124 N 2.3 MI TURN LEFT ONTO E MAIN ST 341 FT TURN RIGHT ONTO PRESTON AVE 0.1 MI TURN RIGHT ONTO CA-124 N 8.0 MI TURN RIGHT ONTO CA-16 E 34 S (0.3 MI) TAKE SHENANDOAH RD AND MT AUKUM RD TO STRAUSS DR IN EL DORADO COUNTY 34 MIN (24.1 MI) CONTINUE ONTO CA-49 N 2.4 MI TURN RIGHT ONTO SHENANDOAH RD 0.5 MI TURN LEFT TO STAY ON SHENANDOAH RD 8.6 MI CONTINUE ONTO MT AUKUM RD 12.4 MI TURN LEFT ONTO PLEASANT VALLEY RD 397 FT TURN RIGHT ONTO STRAUSS DR DESTINATION WILL BE ON THE RIGHT 0.1 MI 4559 STRAUSS DR PLACERVILLE, CA 95667 	<p>SPECIAL INSPECTIONS</p>	<p>APPROVALS</p> <table border="1"> <thead> <tr> <th>APPROVED BY:</th> <th>INITIALS:</th> <th>DATE:</th> </tr> </thead> <tbody> <tr> <td>AT&T:</td> <td></td> <td></td> </tr> <tr> <td>VENDOR:</td> <td></td> <td></td> </tr> <tr> <td>R.F.:</td> <td></td> <td></td> </tr> <tr> <td>LEASING / LANDLORD:</td> <td></td> <td></td> </tr> <tr> <td>ZONING:</td> <td></td> <td></td> </tr> <tr> <td>CONSTRUCTION:</td> <td></td> <td></td> </tr> <tr> <td>POWER / TELCO:</td> <td></td> <td></td> </tr> <tr> <td>PG&E:</td> <td></td> <td></td> </tr> </tbody> </table>	APPROVED BY:	INITIALS:	DATE:	AT&T:			VENDOR:			R.F.:			LEASING / LANDLORD:			ZONING:			CONSTRUCTION:			POWER / TELCO:			PG&E:			<p>Exhibit F Site 3 Pleasant Valley</p>
APPROVED BY:	INITIALS:	DATE:																														
AT&T:																																
VENDOR:																																
R.F.:																																
LEASING / LANDLORD:																																
ZONING:																																
CONSTRUCTION:																																
POWER / TELCO:																																
PG&E:																																
<p>OCCUPANCY AND CONSTRUCTION TYPE</p> <p>OCCUPANCY : U (UNMANNED) CONSTRUCTION TYPE: V-B</p>			<p>GENERAL CONTRACTOR NOTES</p> <p>DO NOT SCALE DRAWINGS</p> <p>THESE DRAWINGS ARE FORMATTED TO BE FULL SIZE AT 24" x 36". CONTRACTOR SHALL VERIFY ALL PLANS AND EXISTING DIMENSIONS AND CONDITIONS ON THE JOBSITE AND SHALL IMMEDIATELY NOTIFY THE ARCHITECT/ENGINEER IN WRITING OF ANY DISCREPANCIES BEFORE PROCEEDING WITH THE WORK OR MATERIAL ORDERS OR BE RESPONSIBLE FOR THE SAME.</p>																													



GENERAL CONSTRUCTION NOTES:

- PLANS ARE INTENDED TO BE DIAGRAMMATIC OUTLINE ONLY, UNLESS NOTED OTHERWISE. THE WORK SHALL INCLUDE FURNISHING MATERIALS, EQUIPMENT, APPURTENANCES AND LABOR NECESSARY TO COMPLETE ALL INSTALLATIONS AS INDICATED ON THE DRAWINGS.
- THE CONTRACTOR SHALL OBTAIN, IN WRITING, AUTHORIZATION TO PROCEED BEFORE STARTING WORK ON ANY ITEM NOT CLEARLY DEFINED OR IDENTIFIED BY THE CONTRACT DOCUMENTS.
- CONTRACTOR SHALL CONTACT USA (UNDERGROUND SERVICE ALERT) AT (800) 227-2600, FOR UTILITY LOCATIONS, 48 HOURS BEFORE PROCEEDING WITH ANY EXCAVATION, SITE WORK OR CONSTRUCTION.
- THE CONTRACTOR SHALL INSTALL ALL EQUIPMENT AND MATERIALS IN ACCORDANCE WITH MANUFACTURER'S RECOMMENDATIONS UNLESS SPECIFICALLY INDICATED OTHERWISE, OR WHERE LOCAL CODES OR REGULATIONS TAKE PRECEDENCE.
- ALL CONSTRUCTION SHALL BE IN ACCORDANCE WITH THE CBC/UBC'S REQUIREMENTS REGARDING EARTHQUAKE RESISTANCE, FOR, BUT NOT LIMITED TO, PIPING, LIGHT FIXTURES, CEILING GRID, INTERIOR PARTITIONS, AND MECHANICAL EQUIPMENT. ALL WORK MUST COMPLY WITH LOCAL EARTHQUAKE CODES AND REGULATIONS.
- REPRESENTATIONS OF TRUE NORTH, OTHER THAN THOSE FOUND ON THE PLOT OF SURVEY DRAWINGS, SHALL NOT BE USED TO IDENTIFY OR ESTABLISH BEARING OF TRUE NORTH AT THE SITE. THE CONTRACTOR SHALL RELY SOLELY ON THE PLOT OF SURVEY DRAWING AND ANY SURVEYOR'S MARKINGS AT THE SITE FOR THE ESTABLISHMENT OF TRUE NORTH, AND SHALL NOTIFY THE ARCHITECT / ENGINEER PRIOR TO PROCEEDING WITH THE WORK IF ANY DISCREPANCY IS FOUND BETWEEN THE VARIOUS ELEMENTS OF THE WORKING DRAWINGS AND THE TRUE NORTH ORIENTATION AS DEPICTED ON THE CIVIL SURVEY. THE CONTRACTOR SHALL ASSUME SOLE LIABILITY FOR ANY FAILURE TO NOTIFY THE ARCHITECT / ENGINEER.
- THE BUILDING DEPARTMENT ISSUING THE PERMITS SHALL BE NOTIFIED AT LEAST TWO WORKING DAYS PRIOR TO THE COMMENCEMENT OF WORK, OR AS OTHERWISE STIPULATED BY THE CODE ENFORCEMENT OFFICIAL HAVING JURISDICTION.
- DO NOT EXCAVATE OR DISTURB BEYOND THE PROPERTY LINES OR LEASE LINES, UNLESS OTHERWISE NOTED.
- ALL EXISTING UTILITIES, FACILITIES, CONDITIONS, AND THEIR DIMENSIONS SHOWN ON THE PLAN HAVE BEEN PLOTTED FROM AVAILABLE RECORDS. THE ARCHITECT / ENGINEER AND THE OWNER ASSUME NO RESPONSIBILITY WHATSOEVER AS TO THE SUFFICIENCY OR THE ACCURACY OF THE INFORMATION SHOWN ON THE PLANS, OR THE MANNER OF THEIR REMOVAL OR ADJUSTMENT. CONTRACTORS SHALL BE RESPONSIBLE FOR DETERMINING EXACT LOCATION OF ALL EXISTING UTILITIES AND FACILITIES PRIOR TO START OF CONSTRUCTION. CONTRACTORS SHALL ALSO OBTAIN FROM EACH UTILITY COMPANY DETAILED INFORMATION RELATIVE TO WORKING SCHEDULES AND METHODS OF REMOVING OR ADJUSTING EXISTING UTILITIES.
- CONTRACTOR SHALL VERIFY ALL EXISTING UTILITIES, BOTH HORIZONTAL AND VERTICALLY, PRIOR TO THE START OF CONSTRUCTION. ANY DISCREPANCIES OR DOUBTS AS TO THE INTERPRETATION OF PLANS SHOULD BE IMMEDIATELY REPORTED TO THE ARCHITECT / ENGINEER FOR RESOLUTION AND INSTRUCTION, AND NO FURTHER WORK SHALL BE PERFORMED UNTIL THE DISCREPANCY IS CHECKED AND CORRECTED BY THE ARCHITECT / ENGINEER. FAILURE TO SECURE SUCH INSTRUCTION MEANS CONTRACTOR WILL HAVE WORKED AT HIS/HER OWN RISK AND EXPENSE.
- ALL NEW AND EXISTING UTILITY STRUCTURES ON SITE AND IN AREAS TO BE DISTURBED BY CONSTRUCTION SHALL BE ADJUSTED TO FINISH ELEVATIONS PRIOR TO FINAL INSPECTION OF WORK.
- ANY DRAIN AND/OR FIELD TILE ENCOUNTERED / DISTURBED DURING CONSTRUCTION SHALL BE RETURNED TO ITS ORIGINAL CONDITION PRIOR TO COMPLETION OF WORK. SIZE, LOCATION AND TYPE OF ANY UNDERGROUND UTILITIES OR IMPROVEMENTS SHALL BE ACCURATELY NOTED AND PLACED ON "AS-BUILT" DRAWINGS BY GENERAL CONTRACTOR, AND ISSUED TO THE ARCHITECT / ENGINEER AT COMPLETION OF PROJECT.
- ALL TEMPORARY EXCAVATIONS FOR THE INSTALLATION OF FOUNDATIONS, UTILITIES, ETC., SHALL BE PROPERLY LAID BACK OR BRACED IN ACCORDANCE WITH CORRECT OCCUPATIONAL SAFETY AND HEALTH ADMINISTRATION (OSHA) REQUIREMENTS.
- INCLUDE MISC. ITEMS PER AT&T SPECIFICATIONS

APPLICABLE CODES, REGULATIONS AND STANDARDS:

SUBCONTRACTOR'S WORK SHALL COMPLY WITH ALL APPLICABLE NATIONAL, STATE, AND LOCAL CODES AS ADOPTED BY THE LOCAL AUTHORITY HAVING JURISDICTION (AHJ) FOR THE LOCATION.

THE EDITION OF THE AHJ ADOPTED CODES AND STANDARDS IN EFFECT ON THE DATE OF CONTRACT AWARD SHALL GOVERN THE DESIGN.

SUBCONTRACTOR'S WORK SHALL COMPLY WITH THE LATEST EDITION OF THE FOLLOWING STANDARDS:

- AMERICAN CONCRETE INSTITUTE (ACI) 318, BUILDING CODE REQUIREMENTS FOR STRUCTURAL CONCRETE
- AMERICAN INSTITUTE OF STEEL CONSTRUCTION (AISC), MANUAL OF STEEL CONSTRUCTION, ASD, NINTH EDITION
- TELECOMMUNICATIONS INDUSTRY ASSOCIATION (TIA) 222-G, STRUCTURAL STANDARD FOR STRUCTURAL ANTENNA TOWER AND ANTENNA SUPPORTING STRUCTURES
- INSTITUTE FOR ELECTRICAL AND ELECTRONICS ENGINEERS (IEEE) 81, GUIDE FOR MEASURING EARTH RESISTIVITY, GROUND IMPEDANCE, AND EARTH SURFACE POTENTIALS OF A GROUND SYSTEM IEEE 1100 (1999) RECOMMENDED PRACTICE FOR POWERING AND GROUNDING OF ELECTRICAL EQUIPMENT.
- IEEE C62.41, RECOMMENDED PRACTICES ON SURGE VOLTAGES IN LOW VOLTAGE AC POWER CIRCUITS (FOR LOCATION CATEGORY "C3" AND "HIGH SYSTEM EXPOSURE")

TIA 607 COMMERCIAL BUILDING GROUNDING AND BONDING REQUIREMENTS FOR TELECOMMUNICATIONS TELCORDIA GR-63 NETWORK
 EQUIPMENT-BUILDING SYSTEM (NEBS): PHYSICAL PROTECTION
 TELCORDIA GR-347 CENTRAL OFFICE POWER WIRING
 TELCORDIA GR-1275 GENERAL INSTALLATION REQUIREMENTS
 TELCORDIA GR-1503 COAXIAL CABLE CONNECTIONS

ANY AND ALL OTHER LOCAL & STATE LAWS AND REGULATIONS

FOR ANY CONFLICTS BETWEEN SECTIONS OF LISTED CODES AND STANDARDS REGARDING MATERIAL, METHODS OF CONSTRUCTION, OR OTHER REQUIREMENTS, THE MOST RESTRICTIVE SHALL GOVERN. WHERE THERE IS CONFLICT BETWEEN A GENERAL REQUIREMENT AND A SPECIFIC REQUIREMENT, THE SPECIFIC REQUIREMENT SHALL GOVERN.

ABBREVIATIONS

A.B.	ANCHOR BOLT	HT.	HEIGHT
ABV.	ABOVE	IGGB.	ISOLATED COPPER GROUND BUS
ACCA	ANTENNA CABLE COVER ASSEMBLY	IN. (")	INCH(ES)
ADD'L	ADDITIONAL	INT.	INTERIOR
A.F.F.	ABOVE FINISHED FLOOR	LB.(#)	POUND(S)
A.F.G.	ABOVE FINISHED GRADE	L.B.	LAG BOLTS
ALUM.	ALUMINUM	L.F.	LINEAR FEET (FOOT)
ALT.	ALTERNATE	L.	LONG(ITUINAL)
ANT.	ANTENNA	MAS.	MASONRY
APPRX.	APPROXIMATE(LY)	MAX.	MAXIMUM
ARCH.	ARCHITECT(URAL)	M.B.	MACHINE BOLT
AWG.	AMERICAN WIRE GAUGE	MECH.	MECHANICAL
BLDG.	BUILDING	MFR.	MANUFACTURER
BLK.	BLOCK	MIN.	MINIMUM
BLKG.	BLOCKING	MISC.	MISCELLANEOUS
BM.	BEAM	MTL.	METAL
B.N.	BOUNDARY NAILING	(N)	NEW
BTCW.	BARE TINNED COPPER WIRE	NO.(#)	NUMBER
B.O.F.	BOTTOM OF FOOTING	N.T.S.	NOT TO SCALE
B/U	BACK-UP CABINET	O.C.	ON CENTER
CAB.	CABINET	OPNG.	OPENING
CANT.	CANTILEVER(ED)	(P)	PROPOSED
C.I.P.	CAST IN PLACE	P/C	PRECAST CONCRETE
CLG.	CEILING	PCS	PERSONAL COMMUNICATION SERVICES
CLR.	CLEAR	PLY.	PLYWOOD
COL.	COLUMN	PPC	POWER PROTECTION CABINET
CONC.	CONCRETE	PRC	PRIMARY RADIO CABINET
CONN.	CONNECTION(OR)	P.S.F.	POUNDS PER SQUARE FOOT
CONST.	CONSTRUCTION	P.S.I.	POUNDS PER SQUARE INCH
CONT.	CONTINUOUS	P.T.	PRESSURE TREATED
d	DIMENSION	PWR.	POWER (CABINET)
DBL	DOUBLE	QTY.	QUANTITY
DEPT.	DEPARTMENT	RAD.(R)	RADIUS
D.F.	DOUGLAS FIR	REF.	REFERENCE
DIA.	DIAMETER	REINF.	REINFORCEMENT(ING)
DIAG.	DIAGONAL	REQ'D/	REQUIRED
DIM.	DIMENSION	RGS.	RIGID GALVANIZED STEEL
DWG.	DRAWING(S)	SCH.	SCHEDULE
DWL	DOWEL(S)	SHT.	SHEET
EA.	EACH	SM.	SIMILAR
EL.	ELEVATION	SPEC.	SPECIFICATIONS
ELEC.	ELECTRICAL	SQ.	SQUARE
ELEV.	ELEVATOR	S.S.	STAINLESS STEEL
EMT.	ELECTRICAL METALLIC TUBING	STD.	STANDARD
E.N.	EDGE NAIL	STRUC.	STRUCTURAL
ENG.	ENGINEER	TEMP.	TEMPORARY
EQ.	EQUAL	THK.	THICK(NESS)
EXP.	EXPANSION	T.N.	TOE NAIL
EXST.(E)	EXISTING	T.O.A.	TOP OF ANTENNA
EXT.	EXTERIOR	T.O.C.	TOP OF CURB
(F)	FUTURE	T.O.F.	TOP OF FOUNDATION
FAB.	FABRICATION(OR)	T.O.P.	TOP OF PLATE (PARAPET)
F.F.	FINISH FLOOR	T.O.S.	TOP OF STEEL
F.G.	FINISH GRADE	T.O.W.	TOP OF WALL
FIN.	FINISH(ED)	TYP.	TYPICAL
FLR.	FLOOR	U.G.	UNDER GROUND
FDN.	FOUNDATION	U.L.	UNDERWRITERS LABORATORY
F.O.C.	FACE OF CONCRETE	UN.L.O.	UNLESS NOTED OTHERWISE
F.O.M.	FACE OF MASONRY	V.I.F.	VERIFY IN FIELD
F.O.S.	FACE OF STUD	W	WIDE (WIDTH)
F.O.W.	FACE OF WALL	W/	WITH
F.S.	FINISH SURFACE	WD.	WOOD
FT.(')	FOOT (FEET)	W.P.	WEATHERPROOF
FTG.	FOOTING	WT.	WEIGHT
G.	GROWTH (CABINET)	C	CENTERLINE
GA.	GAUGE	P	PLATE, PROPERTY LINE
G.I.	GALVANIZE(D)		
G.F.I.	GROUND FAULT CIRCUIT INTERRUPTER		
GLB. (GLU-LAM)	GLUE LAMINATED BEAM		
GPS	GLOBAL POSITIONING SYSTEM		
GRND.	GROUND		
HDR.	HEADER		
HGR.	HANGER		

SYMBOLS LEGEND

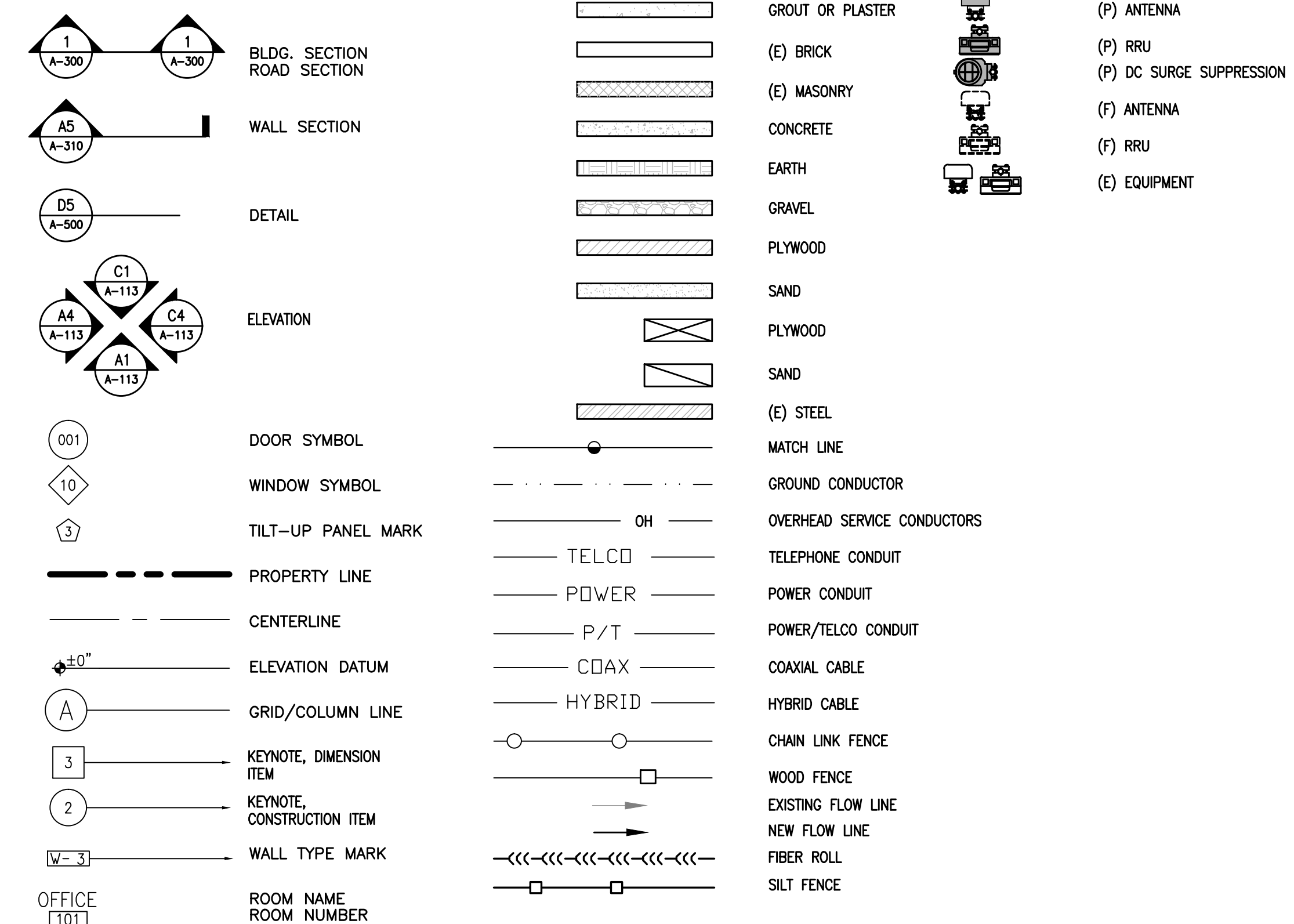

Issued For:
PLEASANT VALLEY
 4559 STRAUSS DRIVE
 PLACERVILLE, CA 95667

PREPARED FOR

 2600 Camino Ramon, 4W850 N
 San Ramon, California 94583

 EPIC WIRELESS GROUP

AT&T SITE NO: CVL03180
 PROJECT NO: 13787610
 DRAWN BY: CES
 CHECKED BY: CES

REV	DATE	DESCRIPTION
0	07/05/17	ZD 90%
1	08/03/17	ZD 100% SHELTER CHANGE

Licensor:

 REGISTERED PROFESSIONAL ENGINEER
 CRAIG M. HORNER
 No. 84674
 CIVIL ENGINEER
 STATE OF CALIFORNIA

IT IS A VIOLATION OF LAW FOR ANY PERSON, UNLESS THEY ARE ACTING UNDER THE DIRECTION OF A LICENSED PROFESSIONAL ENGINEER, TO ALTER THIS DOCUMENT.

Engineer:
ADAPTIVE RE-USE ENGINEERING
 Craig Horner, PE 84674
 214-407-3184
 3112 LEATHA WAY
 SACRAMENTO, CA 95821
 craighorner@yahoo.com

SHEET TITLE:
GENERAL NOTES

SHEET NUMBER:
GN-1

THESE DRAWINGS AND/OR THE ACCOMPANYING SPECIFICATION AS INSTRUMENTS OF SERVICE, ARE THE EXCLUSIVE PROPERTY OF GEIL ENGINEERING AND THEIR USE AND PUBLICATION SHALL BE RESTRICTED TO THE ORIGINAL SITE AND CARRIER FOR WHICH THEY ARE PREPARED. REUSE, REPRODUCTION OR PUBLICATION BY ANY METHOD, IN WHOLE OR IN PART, IS PROHIBITED EXCEPT BY WRITTEN PERMISSION FROM GEIL ENGINEERING TITLE TO THESE PLANS AND/OR SPECIFICATIONS SHALL REMAIN WITH GEIL ENGINEERING WITHOUT PREJUDICE AND VISUAL CONTACT WITH THEM SHALL CONSTITUTE PRIMA FACIE EVIDENCE OF ACCEPTANCE OF THESE RESTRICTIONS.

BOUNDARY SHOWN IS BASED ON MONUMENTATION FOUND AND RECORD INFORMATION. THIS IS NOT A BOUNDARY SURVEY. THIS IS A SPECIALIZED TOPOGRAPHIC MAP WITH PROPERTY LINES AND EASEMENTS BEING A GRAPHIC DEPICTION BASED ON INFORMATION GATHERED FROM VARIOUS SOURCES OF RECORD AND AVAILABLE MONUMENTATION FOUND DURING THE FIELD SURVEY. NO EASEMENTS WERE RESEARCHED OR PLOTTED. PROPERTY LINES AND LINES OF TITLE WERE NOT INVESTIGATED NOR SURVEYED. NO PROPERTY MONUMENTS WERE SET.

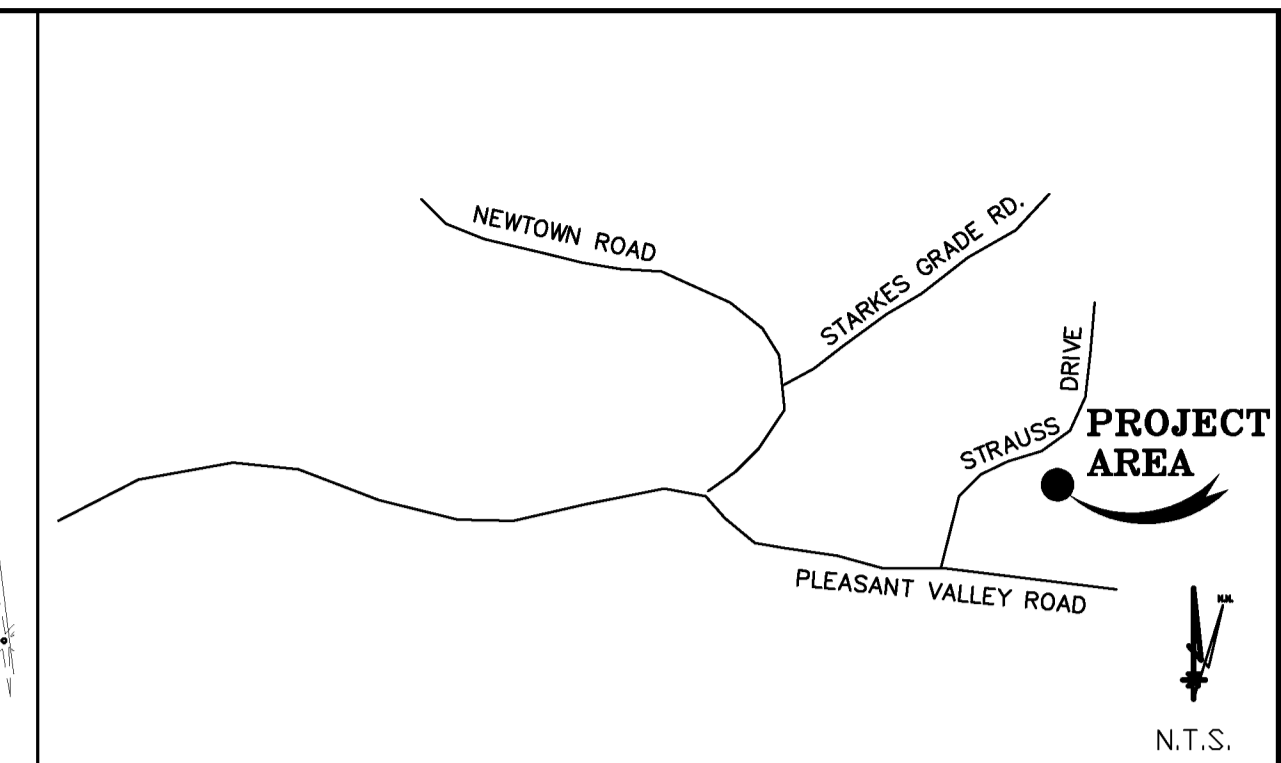
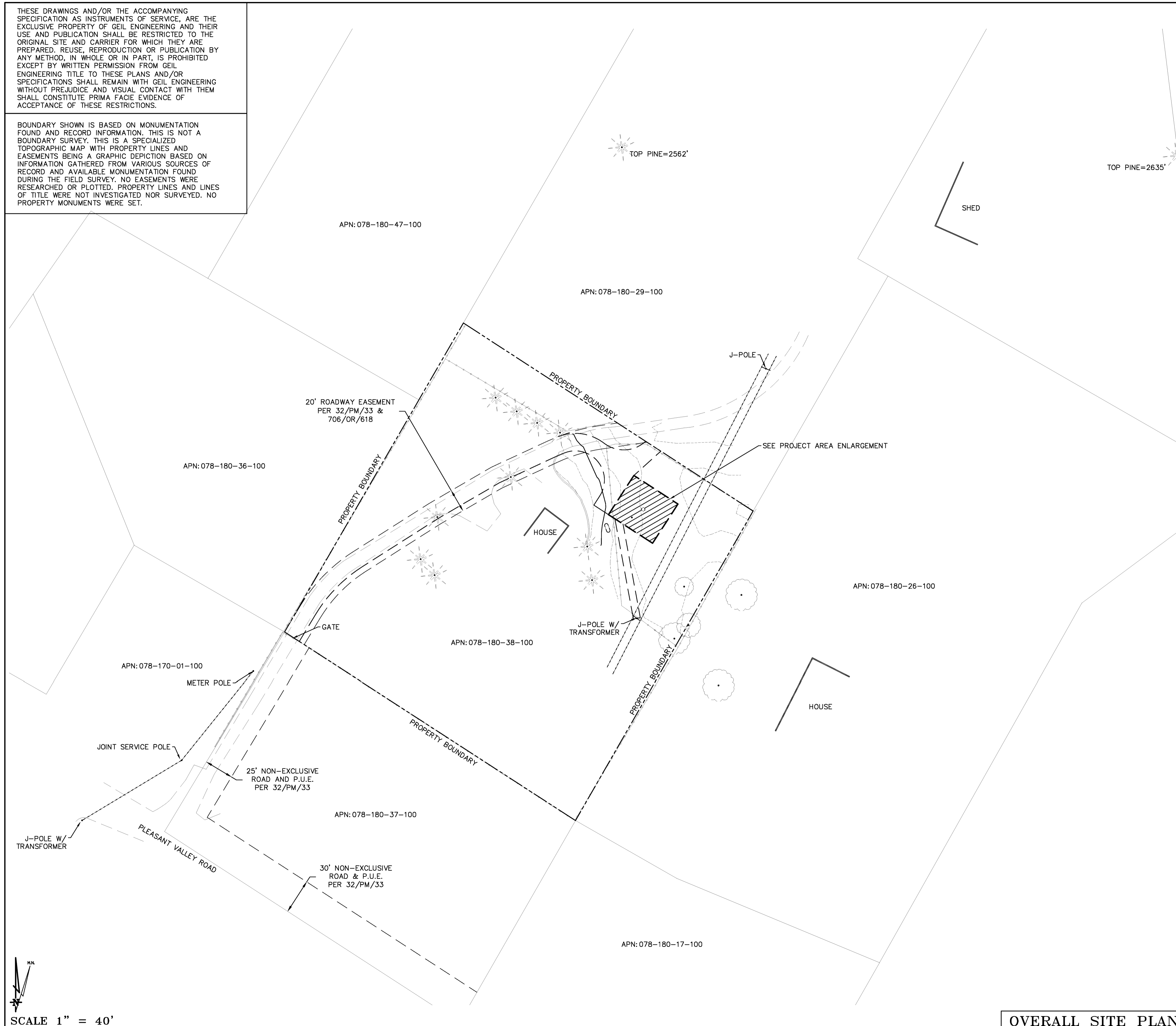

PLACERVILLE, CA VICINITY MAP

Geil Engineering
Engineering * Surveying * Planning
1226 High Street
Auburn, California 95603-5015
Phone: (530) 885-0426 * Fax: (530) 823-1309

A.T.& T. Mobility
Project No./Name: CVL03180 / PLEASANT VALLEY
Project Site Location: 4559 Strauss Drive
Placerville, CA 95667
El Dorado County
Date of Observation: 05-15-17

Equipment/Procedure Used to Obtain Coordinates: Trimble Pathfinder Pro XL post processed with Pathfinder Office software.
Type of Antenna Mount: Proposed Monopine Tower

Coordinates (Tower)
Latitude: N 38° 41' 02.92" (NAD83) N 38° 41' 03.26" (NAD27)
Longitude: W 120° 39' 43.12" (NAD83) W 120° 39' 39.37" (NAD27)
ELEVATION of Ground at Structure (NAVD88) 2497' AMSL

CERTIFICATION: I, the undersigned, do hereby certify elevation listed above is based on a field survey done under my supervision and that the accuracy of those elevations meet or exceed 1-A Standards as defined in the FAA ASAC Information Sheet 91:003, and that they are true and accurate to the best of my knowledge and belief.

Kenneth D. Geil California RCE 14803

Lease Area Description

All that certain lease area being a portion of the Parcel 2 as is shown on that certain Parcel Map filed for record at Book 32 of Parcel Maps, Page 33, El Dorado County Records, located in the County of El Dorado, State of California, and being a portion of Section 28, Township 10 N., Range 12 E., M.D.B.& M., and being more particularly described as follows:

Beginning at a point from which a 3/4" Capped Iron Pipe set at the Southwest corner of the above referenced parcel bears South 70°06'34" West 295.18 feet; thence from said True Point of Beginning North 32°58'23" East 40.00 feet; thence South 57°01'37" East 45.00 feet; thence South 32°58'23" West 40.00 feet; thence North 57°01'37" West 45.00 feet to the point of beginning.

Together with a non-exclusive easement for access and utility purposes fifteen feet in width from the above described lease area and running thence Northwesterly as is shown hereon to the existing access road and easements; thence over, and across said access road and easements as are shown hereon to the public right of way more commonly known as Pleasant Valley Road.

Also together with a non-exclusive easement for utility purposes six feet in width the centerline of which is described as follows: beginning at a point which bears North 57°01'37" West 34.30 feet from most Southerly corner of the above described lease area and running thence South 10°27'46" East 84.4 feet more or less to the existing utility pole.

DATE OF SURVEY: 05-15-17
SURVEYED BY OR UNDER DIRECTION OF: KENNETH D. GEIL, R.C.E. 14803
LOCATED IN THE COUNTY OF EL DORADO, STATE OF CALIFORNIA

BEARINGS SHOWN ARE BASED UPON MONUMENTS FOUND AND RECORD INFORMATION. THIS IS NOT A BOUNDARY SURVEY.
ELEVATIONS SHOWN ON THIS PLAN ARE BASED UPON U.S.G.S. N.A.V.D. 88 DATUM. ABOVE MEAN SEA LEVEL.

N.G.V.D. 1929 CORRECTION: SUBTRACT 2.79' FROM ELEVATIONS SHOWN.

CONTOUR INTERVAL: 1'

CONTRACTOR IS RESPONSIBLE TO VERIFY LEASE AREA PRIOR TO CONSTRUCTION.

ASSESSOR'S PARCEL NUMBER: 078-180-38-100

OWNER(S): VINCENT & JO ANNE GLOWCZWSKIE
4559 STRAUSS DRIVE
PLACERVILLE, CA 95667

OVERALL SITE PLAN

DEPT	APPROVED	DATE
A&C		
RE		
RF		
INT		
EE\IN		
OPS		
EE\OUT		

Surveyor
GEIL ENGINEERING
ENGINEERING * SURVEYING * PLANNING
1226 HIGH STREET
AUBURN, CALIFORNIA 95603
Phone: (530) 885-0426
Fax: (530) 823-1309

Architect
A.T.& T. MOBILITY

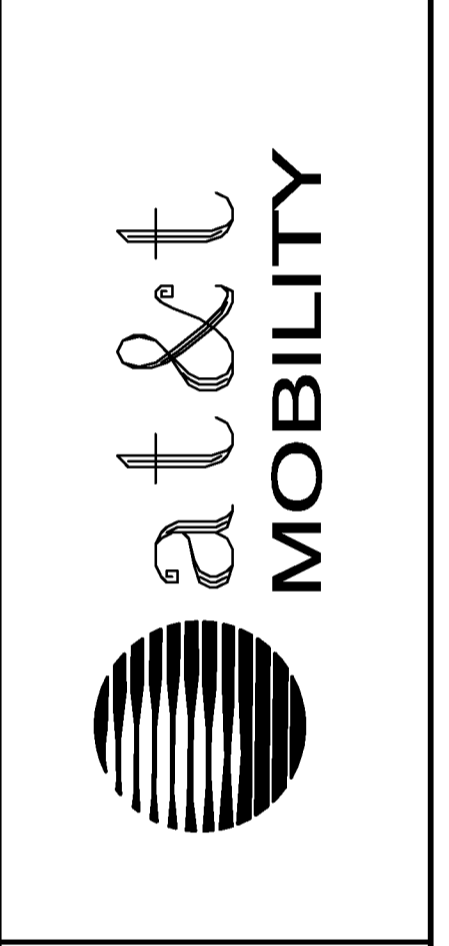

CVL03180
PLEASANT VALLEY
4559 STRAUSS DRIVE
PLACERVILLE, CA 95667
PLOT PLAN AND
SITE TOPOGRAPHY

REV	DATE	DESCRIPTION
05-16-17	N. RONDE	PRELIMINARY DRAWING
06-29-17	N. RONDE	EASEMENT MOD.
07-13-17	N. RONDE	REDLINES

Sheet
C-1

SCALE 1" = 40'

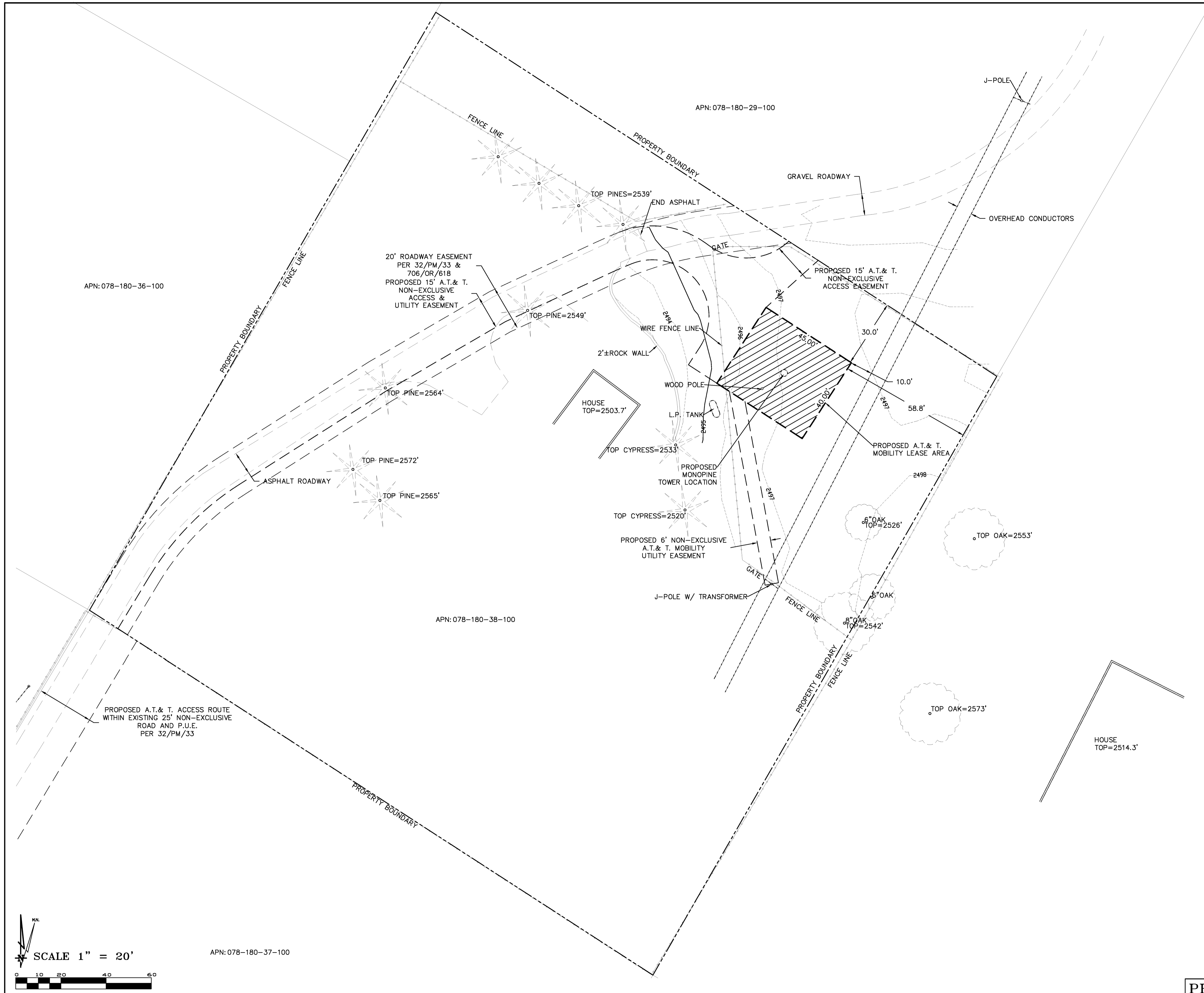

BOUNDARY SHOWN IS BASED ON MONUMENTATION FOUND AND RECORD INFORMATION. THIS IS NOT A BOUNDARY SURVEY. THIS IS A SPECIALIZED TOPOGRAPHIC MAP WITH PROPERTY LINES AND EASEMENTS BEING A GRAPHIC DEPICTION BASED ON INFORMATION GATHERED FROM VARIOUS SOURCES OF RECORD AND AVAILABLE MONUMENTATION FOUND DURING THE FIELD SURVEY. NO EASEMENTS WERE RESEARCHED OR PLOTTED. PROPERTY LINES AND LINES OF TITLE WERE NOT INVESTIGATED NOR SURVEYED. NO PROPERTY MONUMENTS WERE SET.

THESE DRAWINGS AND/OR THE ACCOMPANYING SPECIFICATION AS INSTRUMENTS OF SERVICE, ARE THE EXCLUSIVE PROPERTY OF GEIL ENGINEERING AND THEIR USE AND PUBLICATION SHALL BE RESTRICTED TO THE ORIGINAL SITE AND CARRIER FOR WHICH THEY ARE PREPARED. REUSE, REPRODUCTION OR PUBLICATION BY ANY METHOD, IN WHOLE OR IN PART, IS PROHIBITED EXCEPT BY WRITTEN PERMISSION FROM GEIL ENGINEERING TITLE TO THESE PLANS AND/OR SPECIFICATIONS SHALL REMAIN WITH GEIL ENGINEERING WITHOUT PREJUDICE AND VISUAL CONTACT WITH THEM SHALL CONSTITUTE PRIMA FACIE EVIDENCE OF ACCEPTANCE OF THESE RESTRICTIONS.

DEPT	APPROVED	DATE
A&C		
RE		
RF		
INT		
EE\IN		
OPS		
EE\OUT		

Surveyor
GEIL ENGINEERING
 ENGINEERING • SURVEYING • PLANNING
 1528 HIGH STREET
 AUBURN, CALIFORNIA 95603
 Phone: (530) 885-1888
 Fax: (530) 885-1899

Architect

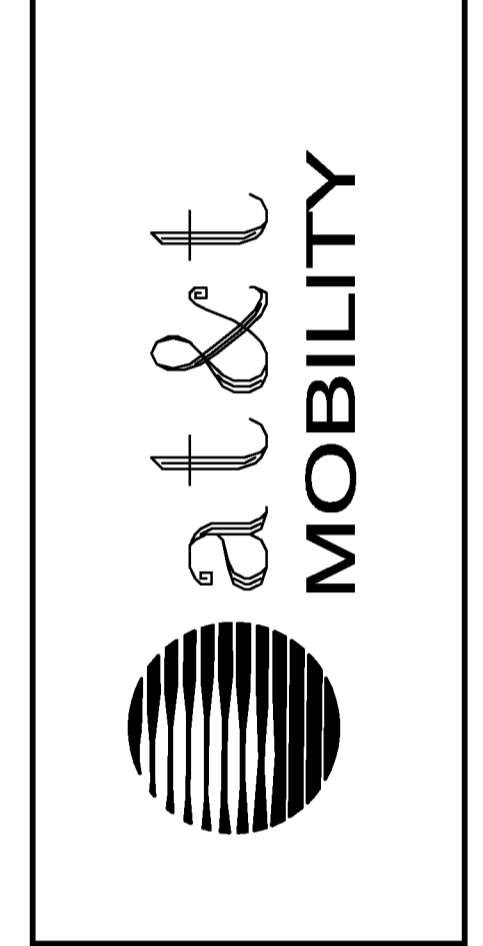

APN: 078-180-26-100

CVL03180
PLEASANT VALLEY
 4559 STRAUSS DRIVE
 PLACERVILLE, CA 95667
 PLOT PLAN AND
 SITE TOPOGRAPHY

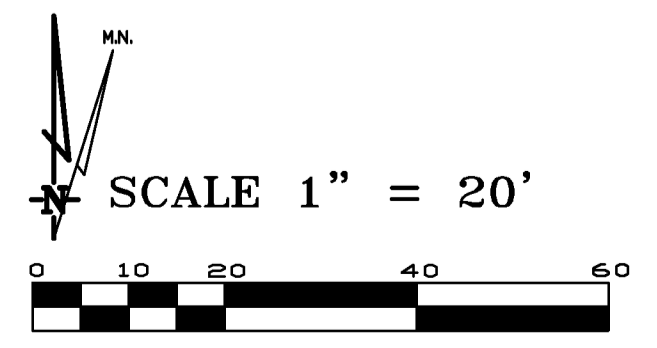

APN: 078-180-37-100

PROJECT AREA ENLARGEMENT

Sheet

C-2

BEST MANAGEMENT PRACTICES "BMP" TABLE			
BEST MANAGEMENT PRACTICES	LOCATION	SCHEDULE IMPLEMENTATION	MAINTENANCE SCHEDULE
PRESERVING EXISTING VEGETATION	AROUND PERIMETER OF PROJECT SITE	CONTINUOUS UNTIL CONSTRUCTION IS COMPLETED	EDUCATE EMPLOYEES AND SUBCONTRACTORS REGARDING IMPORTANCE OF MAINTAINING EXISTING VEGETATION TO PREVENT EROSION AND FILTER OUT SEDIMENT IN RUNOFF FROM DISTURBED AREAS ON THE CONSTRUCTION SITE. INSPECT SITE PERIMETER MONTHLY TO VERIFY THE OUTSIDE VEGETATION IS NOT DISTURBED.
PROTECT GRADED AREAS AND SLOPES FROM WASHOUT AND EROSION	THROUGHOUT PROJECT SITE	CONTINUOUS	INSPECT GRADED AREAS AND SLOPES ON AT LEAST A MONTHLY BASIS TO CHECK FOR EROSION. THE GRADE TRIBUTARY AREAS OR INSTALL SAND DIKES AS NECESSARY TO PREVENT EROSION.
GRAVEL FILTER	ALONG FLOW LINES OF UNPAVED ROADWAYS WITHIN SITE	IN PLACE CONTINUOUSLY UNTIL ROADWAYS ARE PAVED	INSPECT AFTER EACH STORM. REMOVE ONSITE SEDIMENT DEPOSITED BEHIND BERM OR BARRIER TO MAINTAIN EFFECTIVENESS.
BAG INLET FILTER	INLETS TO THE STORM DRAINAGE SYSTEM	CONTINUOUS UNTIL LANDSCAPING IS IN PLACE	INSPECT WEEKLY AND AFTER EACH STORM. REMOVE SEDIMENT AND DEBRIS BEFORE ACCUMULATION HAS REACHED ONE THIRD THE DEPTH OF THE BAG. REPAIR OR REPLACE INLET FILTER BAG AS SOON AS DAMAGE OCCURS.
FIBER ROLLS	SEE NOTE 3 OF EROSION & CONTROL NOTES	CONTINUOUS	INSPECT AFTER EACH STORM. REMOVE SEDIMENT DEPOSITED BEHIND FIBER ROLLS WHENEVER NECESSARY TO MAINTAIN EFFECTIVENESS.
HYDROSEEDING	3:1 SLOPES	IN PLACE DURING BY SEPT. 15	INSPECT SLOPES ON AT LEAST A MONTHLY BASIS TO CHECK FOR EROSION. IF EROSION IS NOTED, SPREAD STRAW MULCH OVER AFFECTED AREAS.
STABILIZED CONSTRUCTION ENTRANCE	ENTRANCES TO SITE FROM PUBLIC ROADWAYS	CONTINUOUS, UNTIL ENTRANCES AND ONSITE ROADWAYS ARE PAVED	INSPECT ON A MONTHLY BASIS AND AFTER EACH RAINFALL. ADD AGGREGATE BASE MATERIAL WHENEVER NECESSARY TO PREVENT SEDIMENT FROM BEING TRACKED INTO PUBLIC STREET.
WIND EROSION CONTROL PRACTICES	WHEREVER NECESSARY THROUGHOUT PROJECT SITE	CONTINUOUS UNTIL GRADING IS COMPLETED AND SOILS HAVE STABILIZED	INSPECT SITE DURING WINDY CONDITIONS TO IDENTIFY AREAS WHERE WIND AND EROSION IS OCCURRING AND ABATE EROSION AS NECESSARY.
GOOD HOUSEKEEPING MEASURES	THROUGHOUT PROJECT SITE	CONTINUOUS UNTIL CONSTRUCTION IS COMPLETED	INSPECT SITE ON AT LEAST A MONTHLY BASIS TO VERIFY GOOD HOUSEKEEPING PRACTICES ARE BEING IMPLEMENTED.
PROPER CONSTRUCTION MATERIAL STORAGE	DESIGNATED AREA	CONTINUOUS UNTIL CONSTRUCTION IS COMPLETED	INSPECT SITE ON AT LEAST A WEEKLY BASIS TO VERIFY THAT CONSTRUCTION MATERIALS ARE STORED IN A MANNER WHICH COULD NOT CAUSE STORM WATER POLLUTION.
PROPER CONSTRUCTION WASTE STORAGE AND DISPOSAL INCLUDING	DESIGNATED COLLECTION AREA AND CONTAINERS	CONTINUOUS UNTIL CONSTRUCTION IS COMPLETED	INSPECT SITE ON AT LEAST A WEEKLY BASIS TO ASSURE WASTE IS STORED PROPERLY AND DISPOSED OF AT LEGAL DISPOSAL SITE, DAILY.
CONCRETE SPILL CLEANUP PAINT & PAINTING SUPPLIES	MATERIAL HANDLING AREAS	IMMEDIATELY AT TIME OF SPILL	INSPECT MATERIAL HANDLING AREAS ON AT LEAST A MONTHLY BASIS TO VERIFY PROPER SPILL CLEANUP.
VEHICLE FUELING, MAINTENANCE & CLEANING	DESIGNATED AREA WITH SECONDARY CONTAINMENT	CONTINUOUS	KEEP AMPLE SUPPLIES OF SPILL CLEANUP MATERIALS ON SITE & INSPECT ON REGULAR SCHEDULE.
STREET AND STORM DRAINAGE FACILITY MAINTENANCE DEFINITIONS	STREETS AND STORM DRAINAGE FACILITIES	CONTINUOUS UNTIL CONSTRUCTION IS COMPLETED	MAINTAIN STORM DRAINAGE FACILITIES AND PAVED STREETS CLEAR OF SEDIMENT AND DEBRIS.

CONSTRUCTION EROSION/SEDIMENTATION CONTROL PLAN NOTES:

- THE CONTRACTOR SHALL FOLLOW TYPICAL GUIDELINES FOR GRADING, EROSION AND SEDIMENT CONTROL FOR THE MEASURES SHOWN OR STATED ON THESE PLANS.
- CONTRACTOR MUST ENSURE THAT THE CONSTRUCTION SITE IS PREPARED PRIOR TO THE ONSET OF ANY STORM. CONTRACTOR SHALL HAVE ALL EROSION AND SEDIMENT CONTROL MEASURES IN PLACE FOR THE WINTER MONTHS PRIOR TO OCTOBER 1.
- ALL EROSION AND SEDIMENT CONTROL MEASURES SHALL BE MAINTAINED UNTIL DISTURBED AREAS ARE STABILIZED. CHANGES TO THIS EROSION AND SEDIMENT CONTROL PLAN SHALL BE MADE TO MEET FIELD CONDITIONS ONLY WITH THE APPROVAL OF OR AT THE DIRECTION OF A REPRESENTATIVE OF THE DEPARTMENT OF UTILITIES.
- THIS PLAN MAY NOT COVER ALL THE SITUATIONS THAT ARISE DURING CONSTRUCTION DUE TO UNANTICIPATED FIELD CONDITIONS. VARIATIONS MAY BE MADE TO THE PLAN IN THE FIELD SUBJECT TO THE APPROVAL OF OR AT THE DIRECTION OF A REPRESENTATIVE OF THE DEPARTMENT OF UTILITIES.
- ALL EROSION AND SEDIMENT CONTROL MEASURES SHALL BE CHECKED BEFORE DURING AND AFTER ALL STORMS TO ENSURE MEASURES ARE FUNCTIONING PROPERLY. REFER TO CURRENT VERSION OF STORMWATER "BMP" MANUAL FOR SPECIFIC SCHEDULE PER SITE CONDITIONS.
- CONTRACTOR SHALL MAINTAIN A LOG AT THE SITE OF ALL INSPECTIONS OR MAINTENANCE OF BMPs, AS WELL AS, ANY CORRECTIVE CHANGES TO THE BMPs OR EROSION AND SEDIMENT CONTROL PLAN.
- IN AREAS WHERE SOIL IS EXPOSED, PROMPT REPLANTING WITH NATIVE COMPATIBLE, DROUGHT-RESISTANT VEGETATION SHALL BE PERFORMED. NO AREAS WILL BE LEFT EXPOSED OVER THE WINTER SEASON.
- THE CONTRACTOR SHALL INSTALL A STABILIZED CONSTRUCTION ENTRANCE PRIOR TO COMMENCEMENT OF CONSTRUCTION WHEN APPLICABLE FOR SITES NOT ACCESSIBLE BY COMMERCIALY PREPARED ACCESSSES. LOCATION OF THE ENTRANCE MAY BE ADJUSTED BY THE CONTRACTOR TO FACILITATE CONSTRUCTION OPERATIONS. ALL CONSTRUCTION TRAFFIC ENTERING THE PAVED ROAD MUST CROSS THE STABILIZED CONSTRUCTION ENTRANCE. THE STABILIZED CONSTRUCTION ENTRANCE (WHEN APPLICABLE) SHALL REMAIN IN PLACE UNTIL THE CONSTRUCTION IS COMPLETE.
- ALL SEDIMENT DEPOSITED ON PAVED ROADWAYS SHALL BE SWEEP AT THE END OF EACH WORKING DAY OR AS NECESSARY.
- CONTRACTOR SHALL PLACE GRAVEL BAGS AROUND ALL NEW DRAINAGE STRUCTURE OPENINGS IMMEDIATELY AFTER THE STRUCTURE OPENING IS CONSTRUCTED. THESE GRAVEL BAGS SHALL BE MAINTAINED AND REMAIN IN PLACE UNTIL CONSTRUCTION IS COMPLETED.
- THE ENTRANCE SHALL BE MAINTAINED IN A CONDITION THAT WILL PREVENT TRACKING OR FLOWING OF SEDIMENT ONTO PUBLIC RIGHT-OF-WAYS. THIS MAY REQUIRE TOP DRESSING, REPAIR AND/OR CLEANOUT OF ANY MEASURES USED TO TRAP SEDIMENT.
- WHEN NECESSARY, WHEELS SHALL BE CLEANED PRIOR TO ENTRANCE ONTO PUBLIC RIGHT-OF-WAY.
- WHEN WASHING IS REQUIRED, IT SHALL BE DONE ON AN AREA STABILIZED WITH CRUSHED STONE THAT DRAINS INTO AN APPROVED SEDIMENT TRAP OR SEDIMENT BASIN.
- CONTRACTOR SHALL IMPLEMENT HOUSEKEEPING PRACTICES AS FOLLOWS:

- SOLID WASTE MANAGEMENT:** PROVIDE DESIGNATED WASTE COLLECTION AREAS AND CONTAINERS. ARRANGE FOR REGULAR REMOVAL AND DISPOSAL. CLEAR SITE OF TRASH INCLUDING ORGANIC DEBRIS, PACKAGING MATERIALS, SCRAP OR SURPLUS BUILDING MATERIALS AND DOMESTIC WASTE DAILY.
 - MATERIAL DELIVERY AND STORAGE:** PROVIDE A DESIGNATED MATERIAL STORAGE AREA WITH SECONDARY CONTAINMENT SUCH AS BERMING. STORE MATERIAL ON PALLETS AND PROVIDE COVERING FOR SOLUBLE MATERIALS. RELOCATE STORAGE AREA INTO BUILDING SHELL WHEN POSSIBLE. INSPECT AREA DAILY.
 - CONCRETE WASTE:** PROVIDE A DESIGNATED AREA FOR A TEMPORARY PIT TO BE USED FOR CONCRETE TRUCK WASH-OUT. DISPOSE OF HARDENED CONCRETE OFFSITE. AT NO TIME SHALL A CONCRETE TRUCK DUMP ITS WASTE AND CLEAN ITS TRUCK INTO THE CITY STORM DRAINS VIA CURB AND GUTTER. INSPECT DAILY TO CONTROL RUNOFF, AND WEEKLY FOR REMOVAL OF HARDENED CONCRETE.
 - PAINT AND PAINTING SUPPLIES:** PROVIDE INSTRUCTION TO EMPLOYEES AND SUBCONTRACTORS REGARDING REDUCTION OF POLLUTANTS INCLUDING MATERIAL STORAGE, USE, AND CLEAN UP. INSPECT SITE DAILY FOR EVIDENCE OF IMPROPER DISPOSAL.
 - VEHICLE FUELING, MAINTENANCE AND CLEANING:** PROVIDE A DESIGNATED FUELING AREA WITH SECONDARY CONTAINMENT SUCH AS BERMING. DO NOT ALLOW MOBILE FUELING OF EQUIPMENT. PROVIDE EQUIPMENT WITH DRIP PANS. RESTRICT ONSITE MAINTENANCE AND CLEANING OF EQUIPMENT TO A MINIMUM. INSPECT AREA DAILY.
 - HAZARDOUS WASTE MANAGEMENT:** PREVENT THE DISCHARGE OF POLLUTANTS FROM HAZARDOUS WASTES TO THE DRAINAGE SYSTEM THROUGH PROPER MATERIAL USE, WASTE DISPOSAL AND TRAINING OF EMPLOYEES. HAZARDOUS WASTE PRODUCTS COMMONLY FOUND ON-SITE INCLUDE BUT ARE NOT LIMITED TO PAINTS & SOLVENTS, PETROLEUM PRODUCTS, FERTILIZERS, HERBICIDES & PESTICIDES, SOIL STABILIZATION PRODUCTS, ASPHALT PRODUCTS AND CONCRETE CURING PRODUCTS.
- USE "BMPs" AT ALL PHASES OF CONSTRUCTION.
 - GRAVEL BAGS WITH FIBER ROLLS/ SILT BARRIER AND OR BAG INLET FILTERS TO BE USED FOR INLET PROTECTION FROM CONSTRUCTION CONTAMINATES. CONTRACTOR TO FIELD IDENTIFY ALL CONDITIONS WHERE THIS MAY APPLY AND MAINTAIN DURING THE COURSE OF CONSTRUCTION. THIS SHALL APPLY TO THE LOCAL SITE ACTIVITY AS WELL AS ANY AREA TRAVELED EXTENDING TO THE POINT OF SITE ACCESS AND ONTO THE PUBLIC RIGHT OF WAYS. NO CONSTRUCTION DEBRIS MAY ENTER ANY STORM WATER DRAIN AT ANY TIME. THE CONTRACTOR SHALL IMPLEMENT MEASURES TO MONITOR THIS AT ALL TIMES DURING THE CONSTRUCTION PHASE.
 - ANY AN ALL STORED MATERIALS, INCLUDING BUT NOT LIMITED TO, EXCAVATED SOIL, IMPORTED ROCK, SAND OR GRAVEL, PAINT, CONCRETE, WOOD, METAL, OR CONTAMINATED WATER SHALL BE STORED PROPERLY TO INSURE NO DISCHARGE OF CONTAMINATES.
 - REMOVE DIRT, DEBRIS AND WEEDS FROM PUBLIC SIDE WALK AREAS AND STORM DRAIN SYSTEMS AND ANY CONSTRUCTION MATERIALS OR DEBRIS TO AN APPROVED LOCATION AS ON A DAILY BASIS (OR AS DIRECTED BY THE CITY ENGINEER). A CONCRETE WASHOUT SHALL BE ONSITE AT ALL TIMES. CONTRACTOR TO FIELD VERIFY LOCATION, AND BEST METHOD TO PREVENT SPILLS AND DISCHARGE OF CONCRETE/ WATER CONTAMINANTS.
 - CONTRACTOR TO FIELD IDENTIFY "BMP"s (BEST MANAGEMENT PRACTICES) PER SITE CONDITIONS. AND REFER TO CURRENT VERSION OF STORMWATER "BMP" MANUAL FOR SPECIFIC SCHEDULES OR DETAILS NOT SPECIFIED IN THIS PLAN.

STORM WATER QUALITY NOTES:

- CONTRACTOR SHALL PROVIDE DRAIN INLET PROTECTION FOR ALL CATCH BASINS LOCATED IN THE VICINITY OF WORK. THIS INCLUDES ANY CATCH BASINS IN THE PUBLIC RIGHT-OF-WAY, AS WELL AS ANY ON-SITE CATCH BASINS ON PRIVATE PROPERTY.
- CONTRACTOR SHALL INSTALL A STABILIZED CONSTRUCTION ENTRANCE/EGRESS FROM PROJECT SITE TO PREVENT TRACK-OUT OF SEDIMENT ONTO THE PUBLIC RIGHT-OF WAY FROM CONSTRUCTION VEHICLES.
- CONTRACTOR SHALL ENSURE THAT CONSTRUCTION ACTIVITIES DO NOT DEPOSIT SEDIMENT ONTO THE PUBLIC ROADWAY, SIDEWALKS AND GUTTERS. ALL SEDIMENT AND CONSTRUCTION DEBRIS MUST BE REMOVED BY THE END OF EACH WORKING DAY. CONTRACTOR SHALL USE STREET SWEEPING OR OTHER DRY SWEEPING METHOD, AS NECESSARY, TO REMOVE CONSTRUCTION OR DEMOLITION-RELATED SEDIMENT FROM PUBLIC SIDEWALKS, GUTTERS AND ROADWAY.
- CONTRACTOR SHALL SCHEDULE WORK FOR DRY-WEATHER DAYS WHEN NO RAIN IS IN THE IMMEDIATE FORECAST.
- CONTRACTOR SHALL INSTALL AN APPROVED WASH-OUT STRUCTURE AT THE CONSTRUCTION SITE. ALL CONCRETE, PAINT, STUCCO AND OTHER LIQUIDS WILL BE WASHED OUT IN THIS AREA. CONTRACTOR SHALL PROVIDE DUST CONTROL TO PREVENT THE NUISANCE OF BLOWING DUST WITHOUT CAUSING SEDIMENT, DEBRIS, OR LITTER TO ENTER THE ANY STORM DRAIN SYSTEM.
- CONTRACTOR SHALL INSTALL ANY OTHER BMPs AS NECESSARY TO CONTROL THE DISCHARGE OF POLLUTANTS FROM THE PROJECT SITE.
- THE CONTRACTOR SHALL BE RESPONSIBLE FOR IMPLEMENTATION AND ADHERENCE TO THE LOCAL REQUIREMENTS.

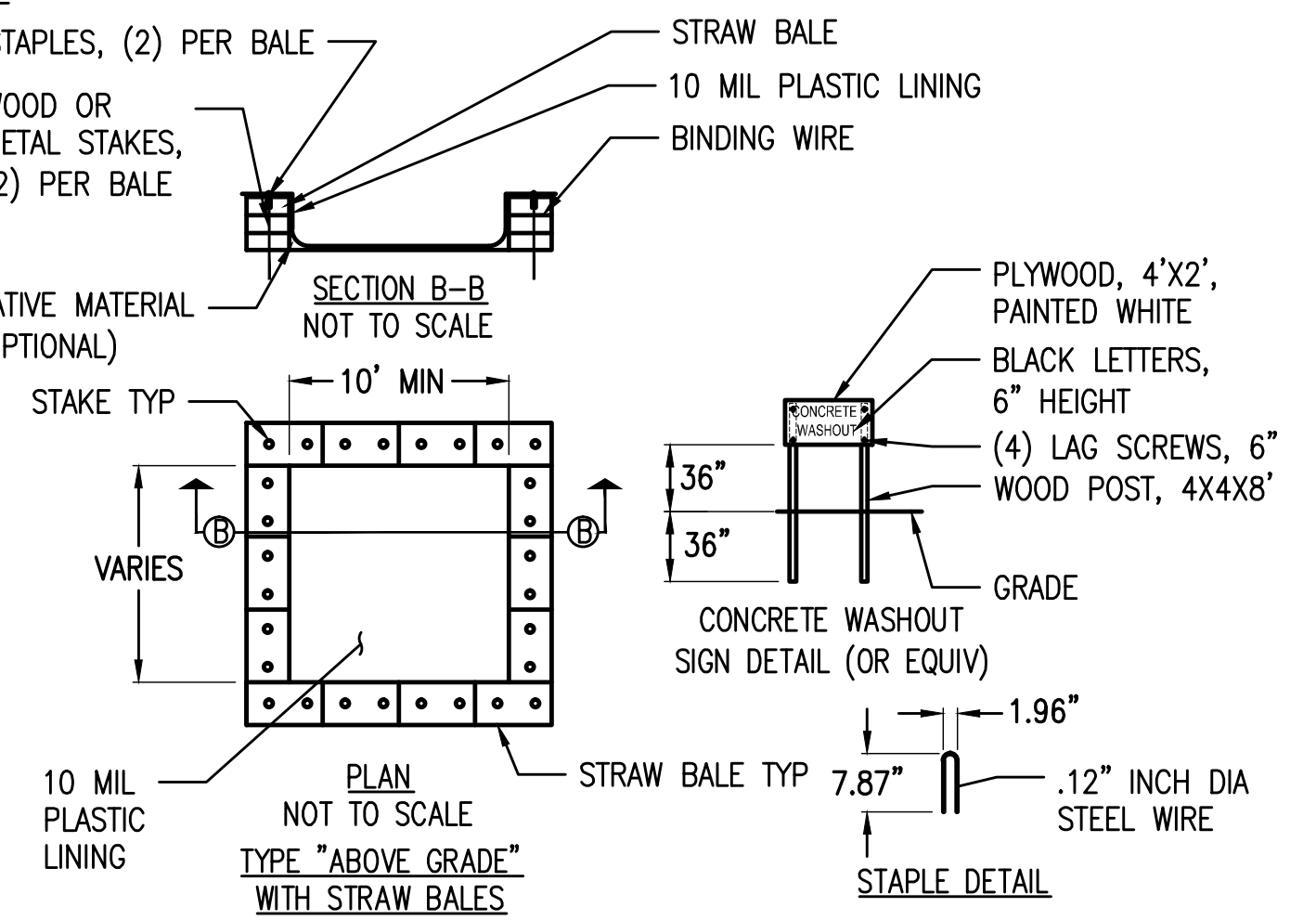

- NOTES:
- ACTUAL LAYOUT DETERMINED IN THE FIELD.
 - THE CONCRETE WASHOUT SIGN SHALL BE INSTALLED WITHIN 32' OF THE TEMPORARY CONCRETE WASHOUT FACILITY.

1 CONCRETE WASHOUT DETAIL NOT TO SCALE

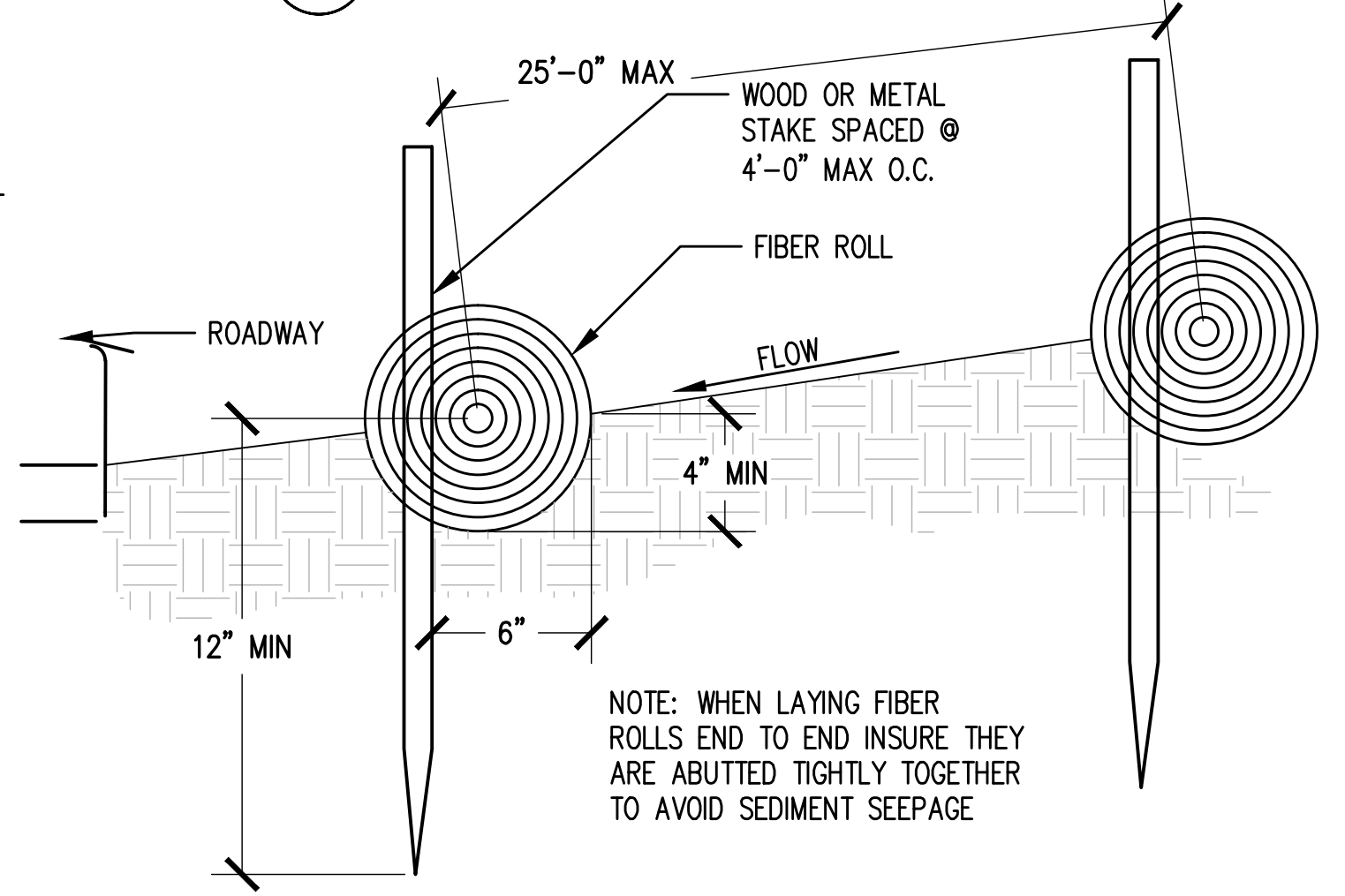

3 FIBER ROLL DETAIL NOT TO SCALE

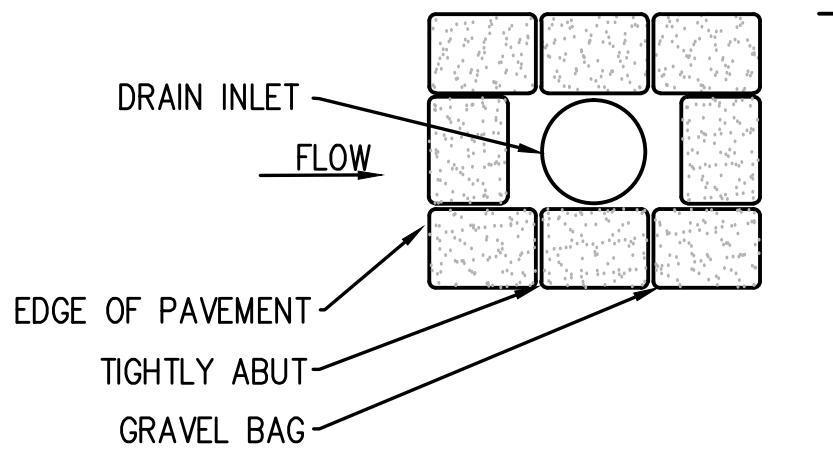

2 DRAIN INLET DETAIL NOT TO SCALE

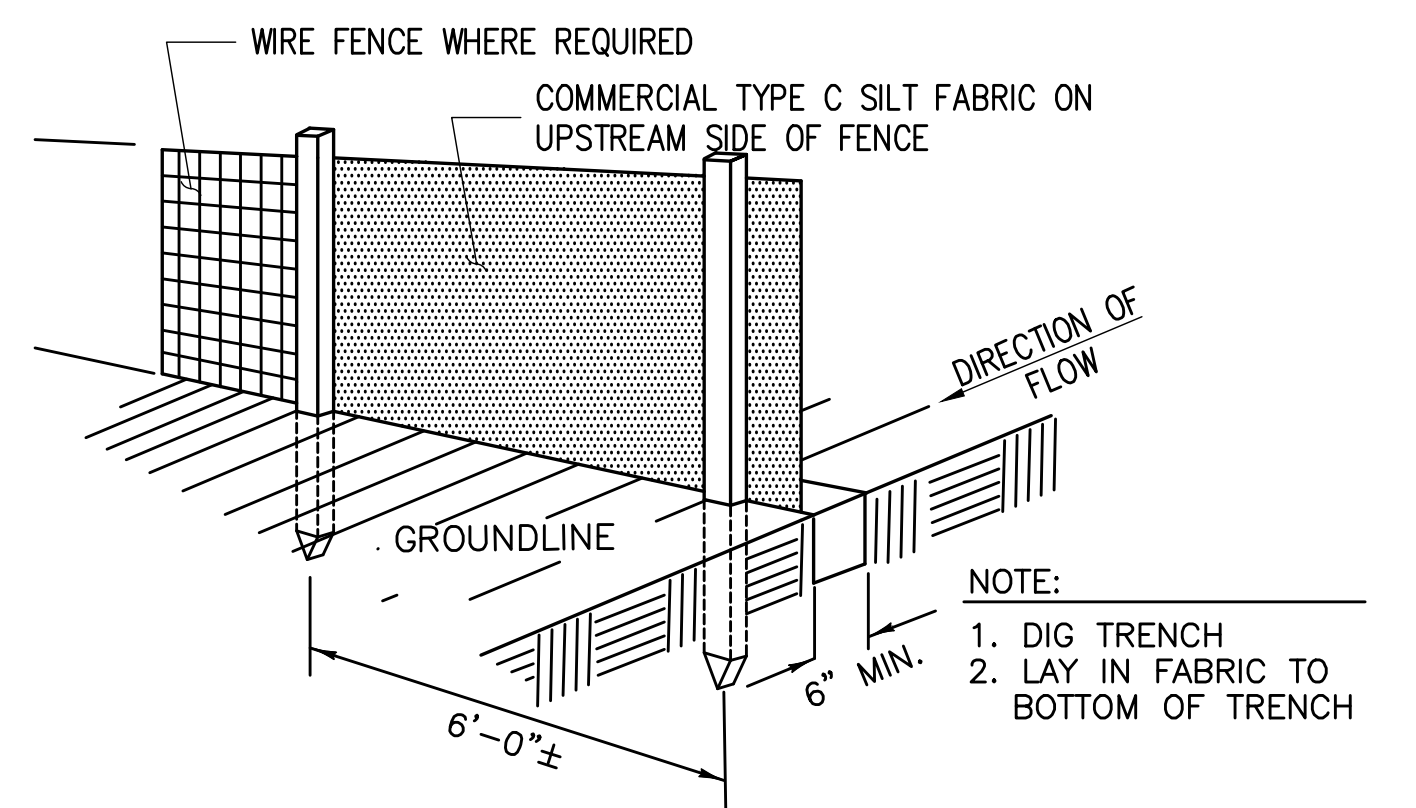

CONSTRUCTION NOTES FOR FABRICATED SILT FENCE

- WOVEN WIRE FENCE TO BE FASTENED SECURELY TO FENCE POSTS WITH WIRE TIES OR STAPLES. POSTS: STEEL EITHER T OR U TYPE OR 4" HARDWOOD. MINIMUM LENGTH - 5 FEET.
- FILTER CLOTH TO BE FASTENED SECURELY TO WOVEN WIRE FENCE WITH TIES SPACED EVERY 24" AT TOP AND MID SECTION. FENCE: WOVEN WIRE, 14 GA. 6" MAX. MESH OPENING. AS DIRECTED BY MARYLAND DCR.
- WHEN TWO SECTIONS OF FILTER CLOTH ADJOIN EACH OTHER THEY SHALL BE OVERLAPPED BY SIX INCHES AND FOLDED. FILTER CLOTH: FILTER X, MIRAFI 100X' STABILINKA T140N OR APPROVED EQUAL.
- MAINTENANCE SHALL BE PERFORMED AS NEEDED AND MATERIAL REMOVED WHEN "BULDGES" DEVELOP IN THE SILT FENCE. PREFABRICATED UNIT: GEOFAB, ENVIROFENCE OR APPROVED EQUAL.

4 TYPE C SILT FENCE DETAIL NOT TO SCALE

FIBER ROLL NOTES:

- REPAIR OR REPLACE SPLIT, TORN UNRAVELING OR SLUMPING FIBER ROLLS. FIBER ROLLS TO BE STAKED 4' O.C. PARALLEL TO (E) CONTOURS.
- INSPECT FIBER ROLLS WHEN RAIN IS FORECAST, DURING AND FOLLOWING RAIN EVENTS, AT LEAST DAILY DURING PROLONGED RAINFALL, FOR SPECIFIC MONITORING INTERVALS REFER TO THE CURRENT VERSION OF STORM WATER "BMP" MANUAL FOR DURING THE NON-RAINY SEASON.
- SEDIMENT SHOULD BE REMOVED WHEN SEDIMENT ACCUMULATION REACHES ONE-HALF THE DESIGNATED SEDIMENT STORAGE DEPTH, USUALLY ONE-HALF THE DISTANCE BETWEEN THE TOP OF THE FIBER ROLL AND THE ADJACENT GROUND SURFACE. SEDIMENT REMOVED DURING MAINTENANCE MAY BE INCORPORATED INTO THE EARTHWORK ON THE SITE OR DISPOSED AT AN APPROPRIATE LOCATION.
- FILTER BARRIER SHALL BE CONSTRUCTED LONG ENOUGH TO EXTEND ACROSS THE EXPECTED FLOW PATH AND AS APPROVED BY THE LANDSCAPE INSPECTOR.

Issued For:
PLEASANT VALLEY
 4559 STRAUSS DRIVE
 PLACERVILLE, CA 95667

PREPARED FOR

 2600 Camino Ramon, 4W850 N
 San Ramon, California 94583

EPIC
 WIRELESS GROUP

AT&T SITE NO: CVL03180
 PROJECT NO: 13787610
 DRAWN BY: CES
 CHECKED BY: CES

REV	DATE	DESCRIPTION
0	07/05/17	ZD 90%
1	08/03/17	ZD 100% SHELTER CHANGE

Licenser:

 IT IS A VIOLATION OF LAW FOR ANY PERSON, UNLESS THEY ARE ACTING UNDER THE DIRECTION OF A LICENSED PROFESSIONAL ENGINEER, TO ALTER THIS DOCUMENT.

Engineer:
ADAPTIVE RE-USE ENGINEERING
 Craig Horner, PE 84674
 214-407-3184
 3112 LEATHA WAY
 SACRAMENTO, CA 95821
 craigmhorner@yahoo.com

SHEET TITLE:
EROSION CONTROL NOTES

SHEET NUMBER:
C-2.1

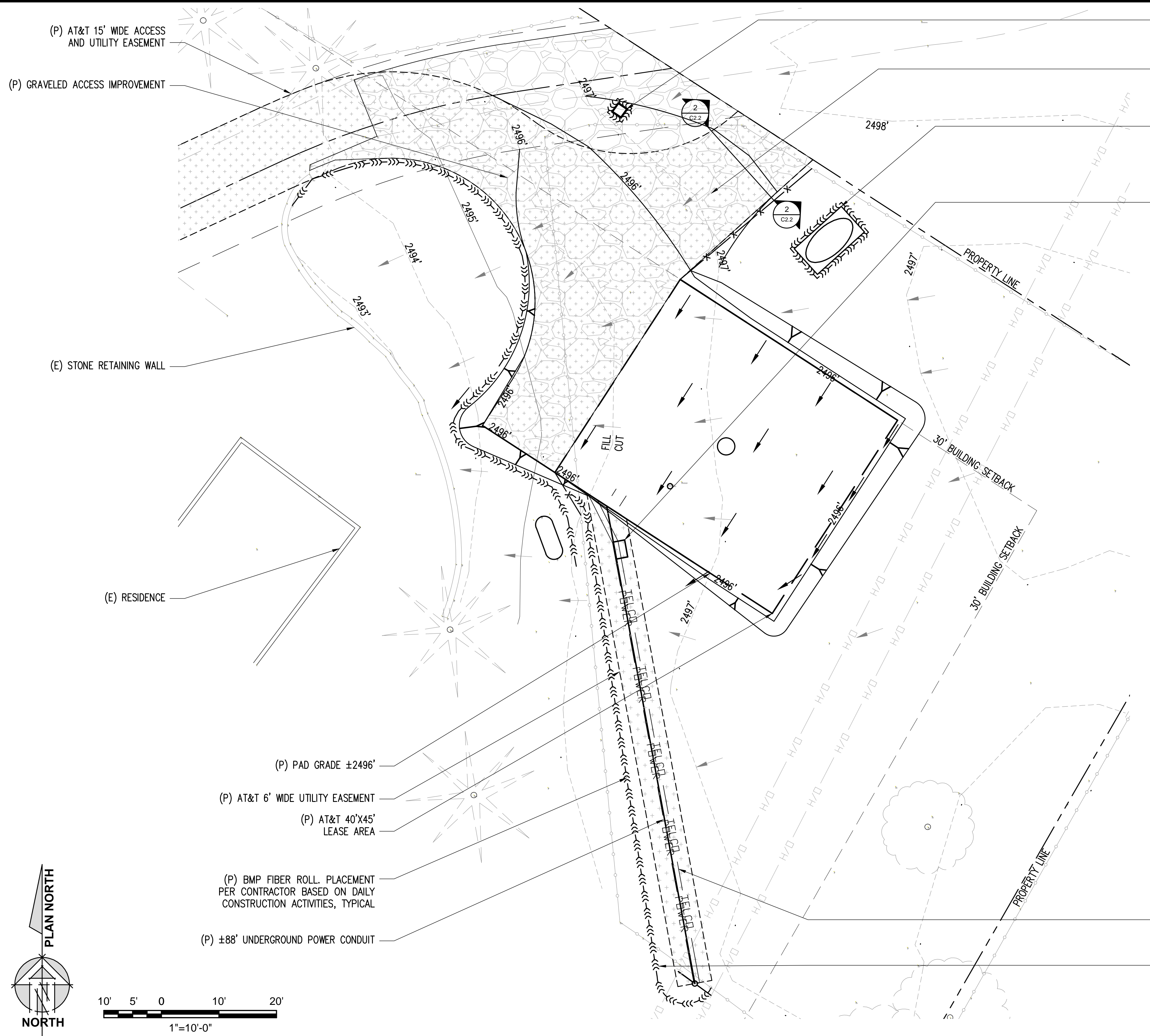

- (P) CONCRETE WASHOUT AREA. ACTUAL PLACEMENT PER CONTRACTOR AS REQUIRED WITH ALL BMP PROTECTION IN PLACE AS OUTLINED PER PLAN
- (P) GRAVELED ACCESS IMPROVEMENT
- (P) TEMPORARY COVERED CONSTRUCTION MATERIAL STORAGE. ACTUAL PLACEMENT PER CONTRACTOR AS REQUIRED WITH ALL BMP PROTECTION IN PLACE AS OUTLINED PER PLAN
- (P) 24"X36" SPLICE BOX BY AT&T MOBILITY

LEGEND

(E) EXISTING	—
(N) PROPOSED	- - - - -
(E) FLOW LINE	→
(N) FLOW LINE	→
(N) FIBER ROLL	←←←←←
(N) SILT FENCE	□

TRENCHING NOTES:
 1. TOTAL TRENCHING LENGTH FOR UNDER GROUND UTILITIES IS 88'±.
 TOTAL CUBIC YARD OF MATERIAL REMOVED AND REPLACED FOR TRENCHING IS 29.33 CUBIC YARDS.

CONSTRUCTION EROSION/ SEDIMENTATION CONTROL PLAN NOTES:

1. USE "BMP'S" AT ALL PHASES OF CONSTRUCTION.
2. GRAVEL BAGS WITH FIBER ROLLS AND SILT BARRIER AS NEEDED AND/OR BAG INLET FILTERS TO BE USED FOR INLET PROTECTION FROM CONSTRUCTION CONTAMINATES. CONTRACTOR TO FIELD IDENTIFY ALL CONDITIONS WHERE THIS MAY APPLY AND MAINTAIN DURING THE COURSE OF CONSTRUCTION. THIS SHALL APPLY TO THE LOCAL SITE ACTIVITY AS WELL AS ANY AREA TRAVELED EXTENDING TO THE POINT OF SITE ACCESS AND ONTO THE PUBLIC RIGHT OF WAYS. NO CONSTRUCTION DEBRIS MAY ENTER ANY STORM WATER DRAIN AT ANY TIME. THE CONTRACTOR SHALL IMPLEMENT MEASURES TO MONITOR THIS AT ALL TIMES DURING THE CONSTRUCTION PHASE.
3. ANY AND ALL STORED MATERIALS, INCLUDING BUT NOT LIMITED TO, EXCAVATED SOIL, IMPORTED ROCK, SAND OR GRAVEL, PAINT, CONCRETE, WOOD, METAL OR CONTAMINATED WATER SHALL BE STORED PROPERLY TO INSURE NO DISCHARGE OF CONTAMINATES.
4. REMOVE DIRT, DEBRIS AND WEEDS FROM PUBLIC SIDE WALK AREAS AND STORM DRAIN SYSTEMS AND ANY CONSTRUCTION MATERIALS OR DEBRIS TO AN APPROVED LOCATION AS ON A DAILY BASIS (OR AS DIRECTED BY THE CITY ENGINEER). A CONCRETE, STUCCO WASHOUT SHALL BE ON SITE AT ALL TIMES CONTRACTOR TO FIELD VERIFY LOCATION AND BEST METHOD TO PREVENT SPILLS AND DISCHARGE OF CONCRETE/WATER CONTAMINANTS.
5. CONTRACTOR TO FIELD IDENTIFY "BMP'S" (BEST MANAGEMENT PRACTICES) PER SITE CONDITIONS AND REFER TO CURRENT VERSION OF STORM WATER "BMP" MANUAL FOR SPECIFIC SCHEDULES OR DETAILS NOT SPECIFIED IN THIS PLAN.
6. INSTALL SEDIMENT LOGS AROUND CONSTRUCTION AREA TO KEEP DEBRIS ON PROPERTY.
7. PLACE GRAVEL BAGS AROUND NEARBY, DOWN STREAM STORM INLET(S) DURING CONSTRUCTION.
8. REPAIR OR REPLACE SPLIT, TORN UNRAVELING OR SLUMPING FIBER ROLLS. FIBER ROLLS TO BE STAKED 4' O.C. PARALLEL TO (E) CONTOURS.
9. INSPECT FIBER ROLLS WHEN RAIN IS FORECAST, DURING AND FOLLOWING RAIN EVENTS, AT LEAST DAILY DURING PROLONGED RAINFALL. FOR SPECIFIC MONITORING INTERVALS REFER TO THE CURRENT VERSION OF STORM WATER "BMP" MANUAL.
10. SEDIMENT SHOULD BE REMOVED WHEN SEDIMENT ACCUMULATION REACHES ONE-HALF THE DESIGNATED SEDIMENT STORAGE DEPTH, USUALLY ONE-HALF THE DISTANCE BETWEEN THE TOP OF THE FIBER ROLL AND THE ADJACENT GROUND SURFACE. SEDIMENT REMOVED DURING MAINTENANCE MAY BE INCORPORATED INTO THE EARTHWORK ON THE SITE OR DISPOSED AT AN APPROPRIATE LOCATION.
11. FILTER BARRIER SHALL BE CONSTRUCTED LONG ENOUGH TO EXTEND ACROSS THE EXPECTED FLOW PATH AND AS APPROVED BY THE LANDSCAPE INSPECTOR.
12. ON-SITE WATER TRUCK MAY BE REQUIRED FOR DUST MITIGATION.

- (P) (1) 4" CONDUIT ±88 BY AT&T MOBILITY
- (P) U/G UTILITY TRENCH

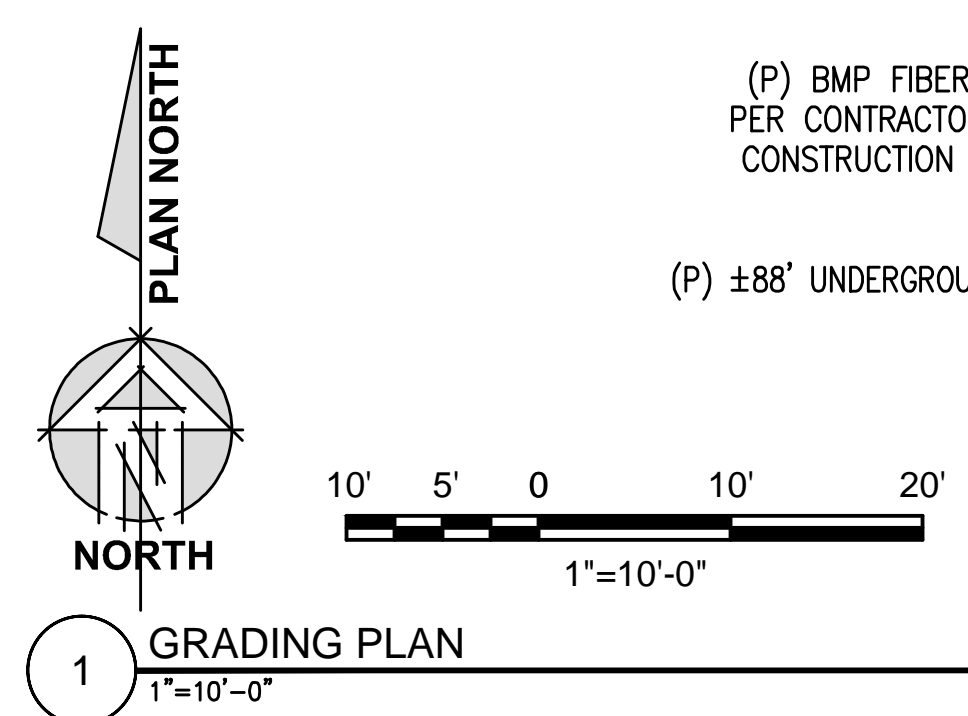

1 GRADING PLAN
1"=10'-0"

SITE TYPE: MONOPINE/SHELTER

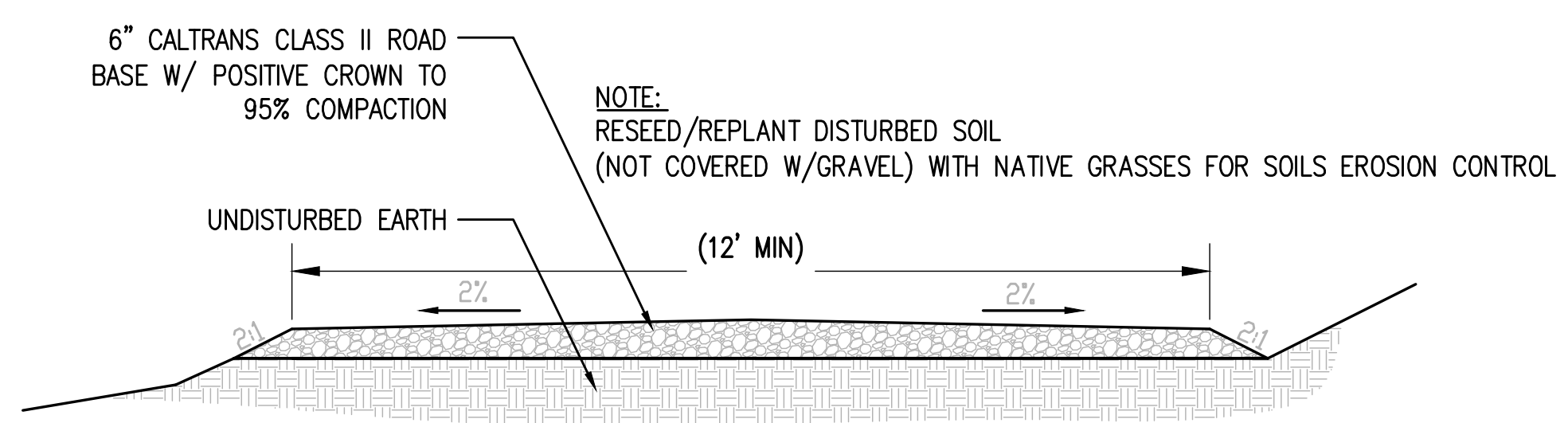

2 ACCESS ROAD DETAIL
NOT TO SCALE

Issued For:
PLEASANT VALLEY
 4559 STRAUSS DRIVE
 PLACERVILLE, CA 95667

PREPARED FOR

 2600 Camino Ramon, 4W850 N
 San Ramon, California 94583

EPIC
 WIRELESS GROUP

AT&T SITE NO: CVL03180
 PROJECT NO: 13787610
 DRAWN BY: CES
 CHECKED BY: CES

REV	DATE	DESCRIPTION
0	07/05/17	ZD 90%
1	08/03/17	ZD 100% SHELTER CHANGE

Licenser:

 REGISTERED PROFESSIONAL ENGINEER
 CRAIG M. HORNER
 No. 84674
 CIVIL
 STATE OF CALIFORNIA

IT IS A VIOLATION OF LAW FOR ANY PERSON, UNLESS THEY ARE ACTING UNDER THE DIRECTION OF A LICENSED PROFESSIONAL ENGINEER, TO ALTER THIS DOCUMENT.

Engineer:
ADAPTIVE RE-USE ENGINEERING
 Craig Horner, PE 84674
 214-407-3184
 3112 LEATHA WAY
 SACRAMENTO, CA 95821
 craigmhorner@yahoo.com

SHEET TITLE:
GRADING PLAN AND DETAILS

SHEET NUMBER:
C-2.2

THIS IS NOT A SITE SURVEY

ALL PROPERTY BOUNDARIES, ORIENTATION OF TRUE NORTH AND STREET HALF-WIDTHS HAVE BEEN OBTAINED FROM A TAX PARCEL MAP AND EXISTING DRAWINGS AND ARE APPROXIMATE.

NOTES:

1. NO GRADING OR PERMANENT CONSTRUCTION SHALL OCCUR WITHIN DRIP LINES OF TREES THAT ARE TO REMAIN WITHOUT ARBORIST APPROVAL.
2. PRIOR TO CONSTRUCTION, GENERAL CONTRACTOR TO CONTACT DIGALERT TO MARK OUT EXISTING UNDERGROUND UTILITIES. IN THE EVENT OF CONFLICTS, CONTRACTOR TO CONTACT PDC.

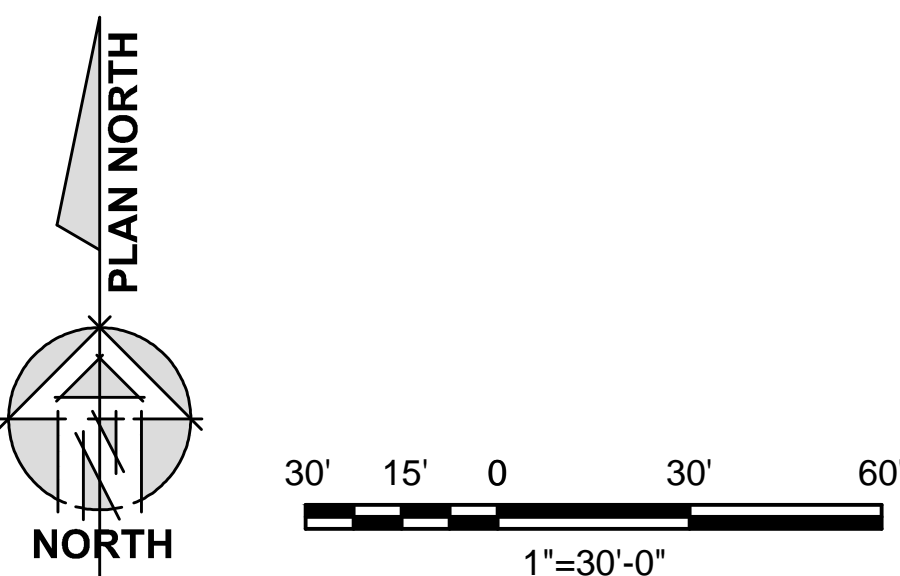
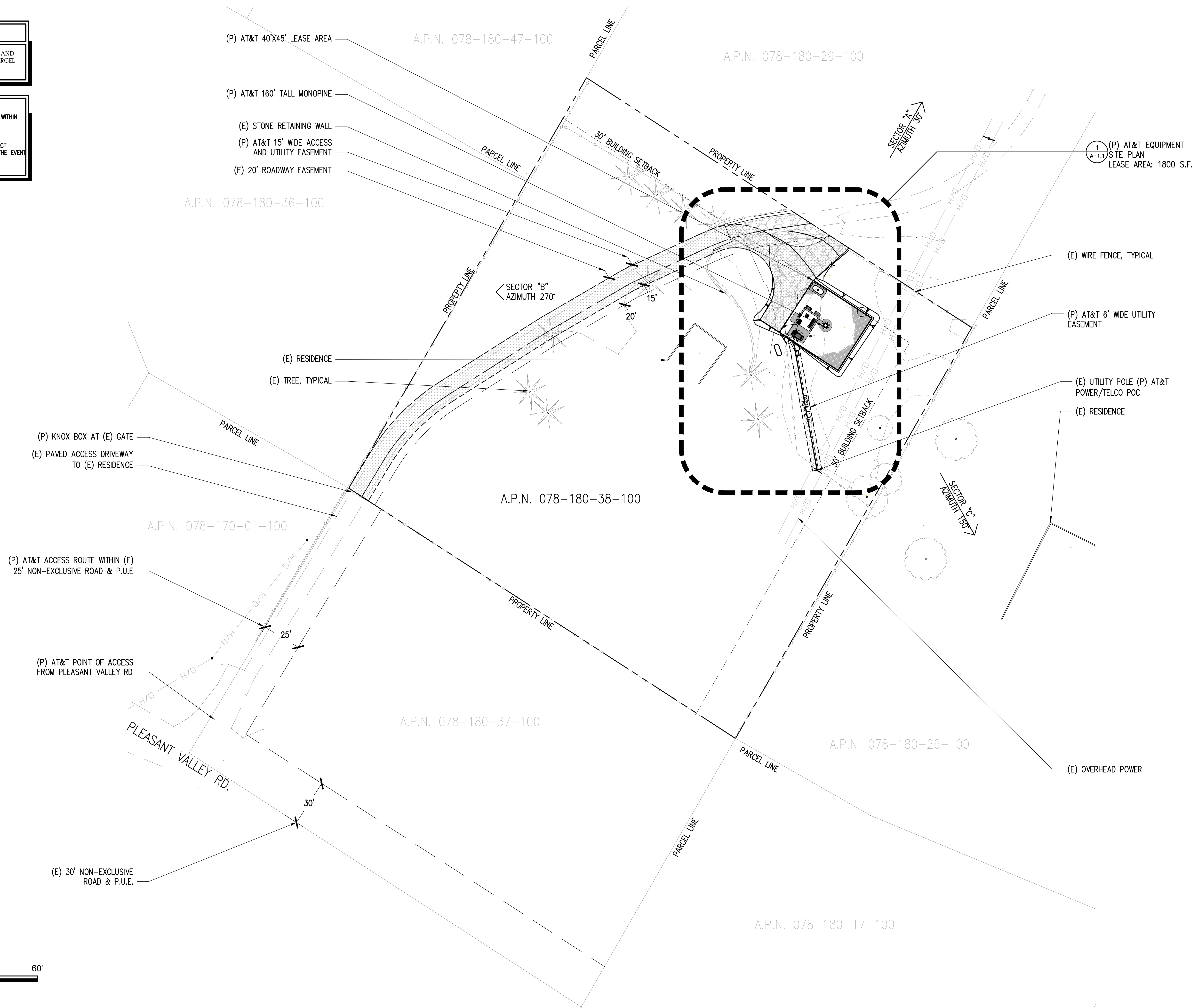

Issued For:
PLEASANT VALLEY
 4559 STRAUSS DRIVE
 PLACERVILLE, CA 95667

PREPARED FOR

 2600 Camino Ramon, 4W850 N
 San Ramon, California 94583

WIRELESS GROUP

AT&T SITE NO: CVL03180
 PROJECT NO: 13787610
 DRAWN BY: CES
 CHECKED BY: CES

REV	DATE	DESCRIPTION
0	07/05/17	ZD 90%
1	08/03/17	ZD 100% SHELTER CHANGE

Licensors:

IT IS A VIOLATION OF LAW FOR ANY PERSON, UNLESS THEY ARE ACTING UNDER THE DIRECTION OF A LICENSED PROFESSIONAL ENGINEER, TO ALTER THIS DOCUMENT.

Engineer:
ADAPTIVE RE-USE ENGINEERING
 Craig Horner, PE 84674
 214-407-3184
 3112 LEATHA WAY
 SACRAMENTO, CA 95821
 craighorner@yahoo.com

SHEET TITLE:
OVERALL SITE PLAN

SHEET NUMBER:
A-1

1 OVERALL SITE PLAN
 1"=30'-0"

SITE TYPE: MONOPINE/SHELTER

THIS IS NOT A SITE SURVEY
 ALL PROPERTY BOUNDARIES, ORIENTATION OF TRUE NORTH AND STREET HALF-WIDTHS HAVE BEEN OBTAINED FROM A TAX PARCEL MAP AND EXISTING DRAWINGS AND ARE APPROXIMATE.

NOTES:
 1. NO GRADING OR PERMANENT CONSTRUCTION SHALL OCCUR WITHIN DRIP LINES OF TREES THAT ARE TO REMAIN WITHOUT ARBORIST APPROVAL.
 2. PRIOR TO CONSTRUCTION, GENERAL CONTRACTOR TO CONTACT DIGALERT TO MARK OUT EXISTING UNDERGROUND UTILITIES. IN THE EVENT OF CONFLICTS, CONTRACTOR TO CONTACT PDC.

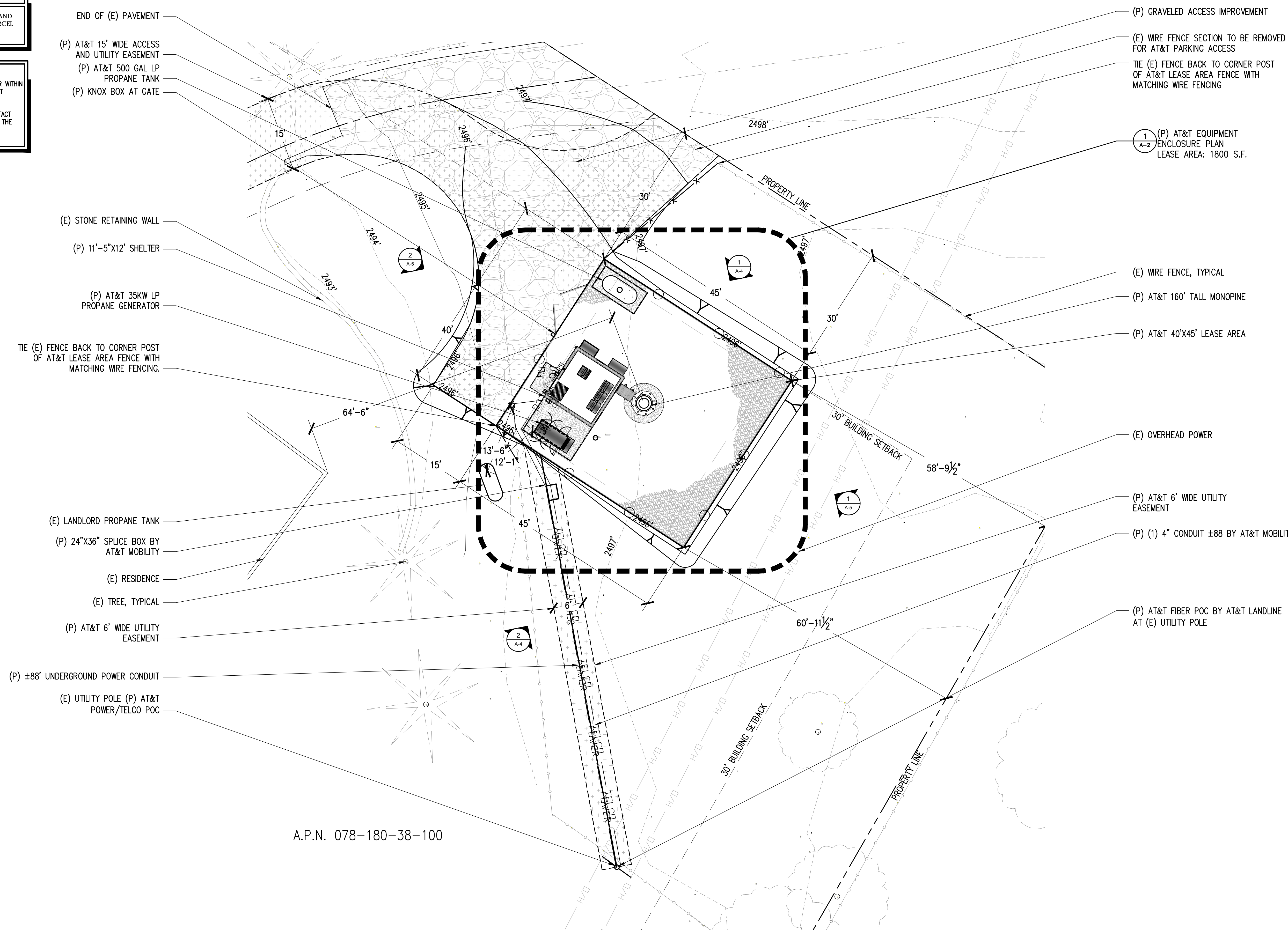

- (P) GRAVELED ACCESS IMPROVEMENT
- (E) WIRE FENCE SECTION TO BE REMOVED FOR AT&T PARKING ACCESS
- TIE (E) FENCE BACK TO CORNER POST OF AT&T LEASE AREA FENCE WITH MATCHING WIRE FENCING
- 1 (P) AT&T EQUIPMENT ENCLOSURE PLAN LEASE AREA: 1800 S.F.

- END OF (E) PAVEMENT
- (P) AT&T 15' WIDE ACCESS AND UTILITY EASEMENT
- (P) AT&T 500 GAL LP PROPAINE TANK
- (P) KNOX BOX AT GATE
- (E) STONE RETAINING WALL
- (P) 11'-5"x12' SHELTER
- (P) AT&T 35KW LP PROPAINE GENERATOR
- TIE (E) FENCE BACK TO CORNER POST OF AT&T LEASE AREA FENCE WITH MATCHING WIRE FENCING.
- (E) LANDLORD PROPAINE TANK
- (P) 24"x36" SPLICE BOX BY AT&T MOBILITY
- (E) RESIDENCE
- (E) TREE, TYPICAL
- (P) AT&T 6' WIDE UTILITY EASEMENT
- (P) ±88' UNDERGROUND POWER CONDUIT
- (E) UTILITY POLE (P) AT&T POWER/TELCO POC

- (E) WIRE FENCE, TYPICAL
- (P) AT&T 160' TALL MONOPINE
- (P) AT&T 40'X45' LEASE AREA
- (E) OVERHEAD POWER
- (P) AT&T 6' WIDE UTILITY EASEMENT
- (P) (1) 4" CONDUIT ±88 BY AT&T MOBILITY
- (P) AT&T FIBER POC BY AT&T LANDLINE AT (E) UTILITY POLE

A.P.N. 078-180-38-100

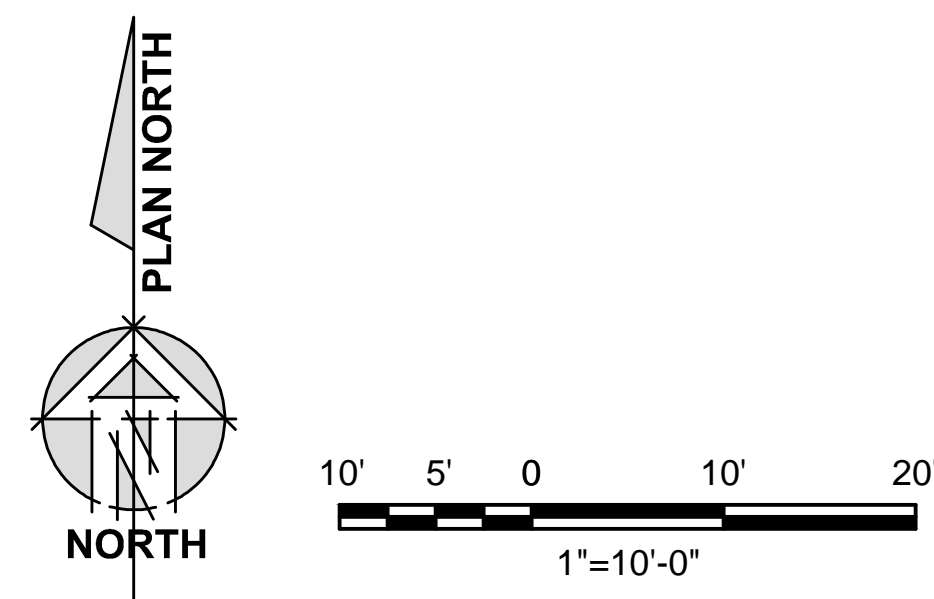

1 SITE PLAN
 1"=10'-0"

SITE TYPE: MONOPINE/SHELTER

Issued For:
PLEASANT VALLEY
 4559 STRAUSS DRIVE
 PLACERVILLE, CA 95667

PREPARED FOR

2600 Camino Ramon, 4W850 N
 San Ramon, California 94583

EPIC WIRELESS GROUP

AT&T SITE NO:	CVL03180
PROJECT NO:	13787610
DRAWN BY:	CES
CHECKED BY:	CES

REV	DATE	DESCRIPTION
0	07/05/17	ZD 90%
1	08/03/17	ZD 100% SHELTER CHANGE

Licenser:

IT IS A VIOLATION OF LAW FOR ANY PERSON, UNLESS THEY ARE ACTING UNDER THE DIRECTION OF A LICENSED PROFESSIONAL ENGINEER, TO ALTER THIS DOCUMENT.

Engineer:
ADAPTIVE RE-USE ENGINEERING
 Craig Horner, PE 84674
 214-407-3184
 3112 LEATHA WAY
 SACRAMENTO, CA 95821
 craighorner@yahoo.com

SHEET TITLE:
SITE PLAN

SHEET NUMBER:
A-1.1

Issued For:
PLEASANT VALLEY
 4559 STRAUSS DRIVE
 PLACERVILLE, CA 95667

PREPARED FOR

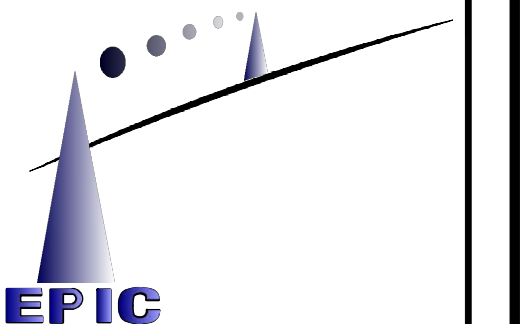
 2600 Camino Ramon, 4W850 N
 San Ramon, California 94583

EPIC
 WIRELESS GROUP

AT&T SITE NO: CVL03180
 PROJECT NO: 13787610
 DRAWN BY: CES
 CHECKED BY: CES

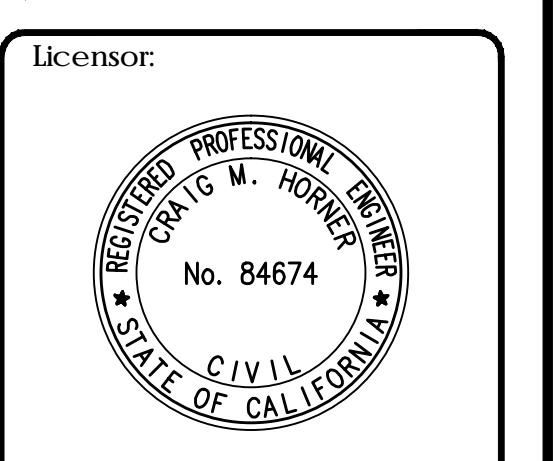
REV	DATE	DESCRIPTION
0	07/05/17	ZD 90%
1	08/03/17	ZD 100% SHELTER CHANGE



IT IS A VIOLATION OF LAW FOR ANY PERSON, UNLESS THEY ARE ACTING UNDER THE DIRECTION OF A LICENSED PROFESSIONAL ENGINEER, TO ALTER THIS DOCUMENT.

Engineer:
ADAPTIVE RE-USE ENGINEERING
 Craig Horner, PE 84674
 214-407-3184
 3112 LEATHA WAY
 SACRAMENTO, CA 95821
 craigmhorner@yahoo.com

SHEET TITLE:
EQUIPMENT AREA PLAN

SHEET NUMBER:
A-2

KEYNOTES

- 1 (P) RF RACK #1
- 2 (P) RF RACK #2
- 3 (P) POWER PLANT RACK W/ (2) STRINGS OF BATTERIES
- 4 (P) TELCO RACK
- 5 (P) 2A208C RATED FIRE EXTINGUISHER IN WEATHER RESISTANT CABINET
- 6 (P) GPS UNIT
- 7 (P) CAMLOCK GENERATOR INTERFACE
- 8 (P) 35KW LP PROPANE STANDBY GENERATOR
- 9 (P) 500 GAL LP PROPANE STORAGE TANK TO BE LEASED FROM SUBURBAN PROPANE
- 10 (P) 12'-0" WIDE ACCESS GATE
- 11 (P) 6'-0" CHAIN LINK FENCE W/ 3 STRAND ANTI CLIMB BARRIER AND GREEN VINYL SLATS
- 12 (P) 18"x18"x12" TELCO PULL CAN BY AT&T MOBILITY
- 13 (P) 153'-00" MONOPOLE W/ 7' BRANCH CROWN TO 160' OVER ALL HEIGHT
- 14 (P) ICE BRIDGE
- 15 (P) AT&T 11'-5" x 12'-0" PRE-MANUFACTURED EQUIPMENT SHELTER
- 16 (P) 200A 42 CIRCUIT LOAD CENTER / AUTOMATIC & MANUAL TRANSFER SWITCH
- 17 (P) TELCO BOARD BY AT&T MOBILITY
- 18 (P) 4 TON HVAC UNIT
- 19 (P) 6'-0" x 3'-6" CONCRETE STOOP
- 20 (P) 200A MAIN DISCONNECT
- 21 (P) GRAVEL BED
- 22 (P) AT&T 40'x45' LEASE AREA
- 23 (P) 5'x10 SLAB
- 24 (P) GEN PATIO
- 25 (P) TOWER CAISSON (DESIGN BY OTHERS)
- 26 (P) 1/2" TOWER MATT SLAB (DESIGN BY OTHERS)
- 27 (P) FIRE DEPARTMENT KNOX BOX
- 28 (P) CARRIER CONTACT SIGNAGE AT GATE
- 29 (P) 24" MAX BRANCH DIAMETER AT BASE OF (P) MONOPOLE
- 30 (P) 300A ELECTRICAL METER WITH MAIN DISCONNECT ON (P) H-FRAME
- 31 (P) CENNA CABINET BY AT&T
- 32 (P) SHIELDED DOWN TILT LIGHT WITH MOTION SENSOR AND AUTO SHUTOFF TIMER PROVIDED WITH EQUIPMENT CABINET
- 33 (P) UTILITY H-FRAME
- 34 (P) UNDERGROUND UTILITY CONDUITS
- 35 (P) BBC-13X 1.2LB PSF MIN. OR EQUIV., SOUND BLANKET AT INTERIOR SIDE OF FENCE

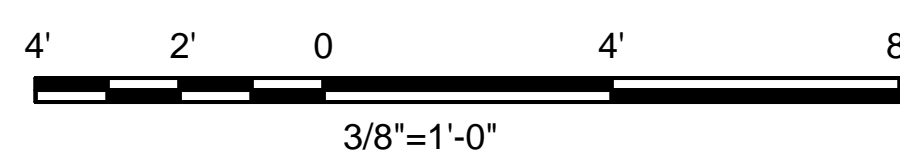
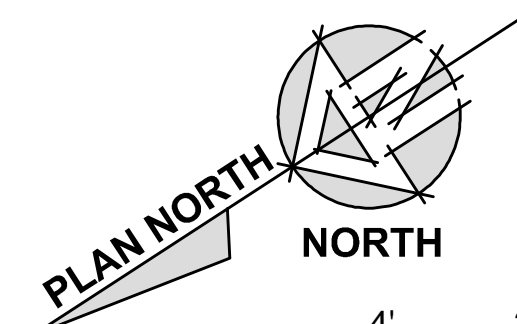
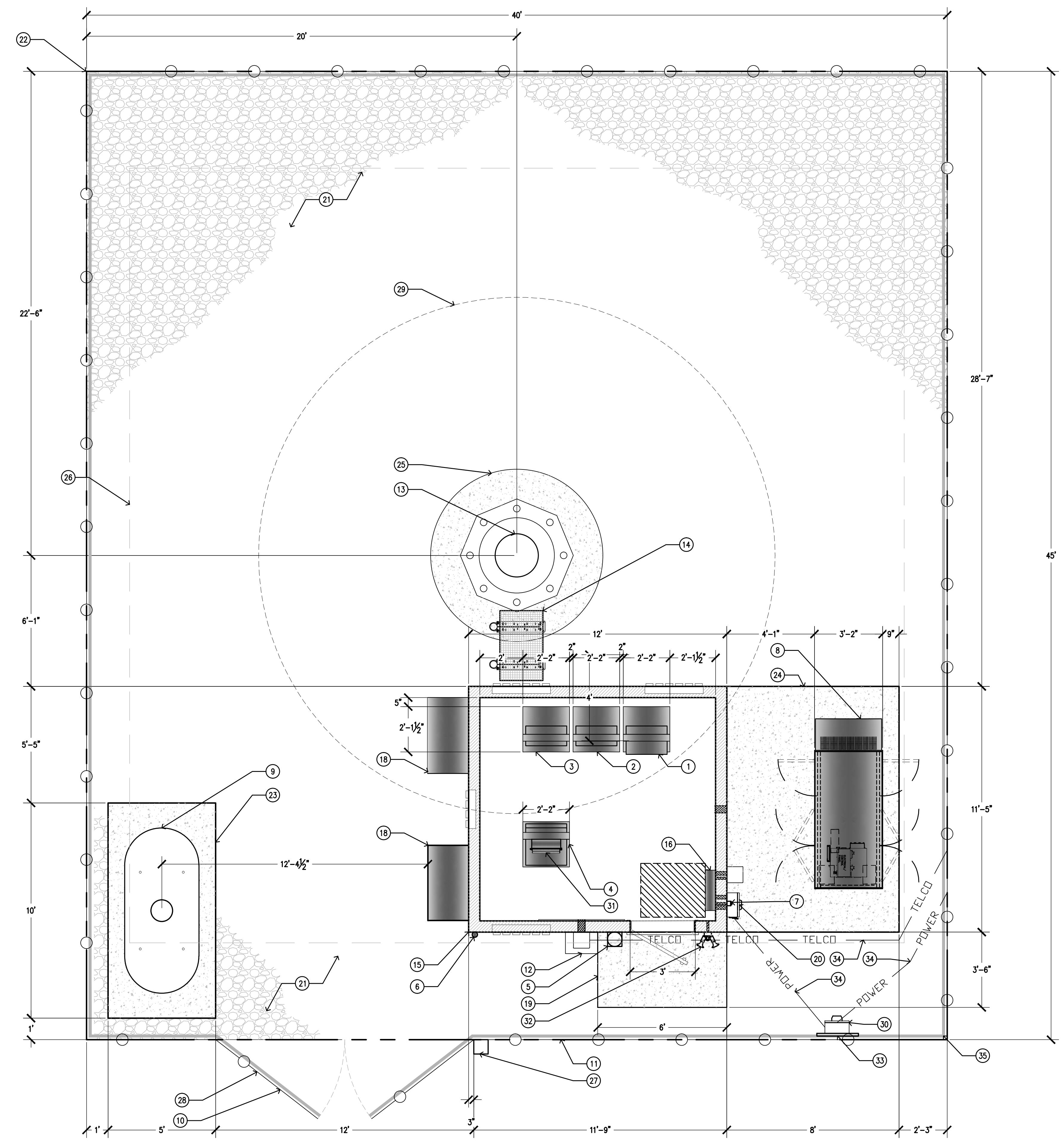

1 EQUIPMENT ENCLOSURE PLAN - EXTERIOR SHELTER
 3/8"=1'-0"

SITE TYPE: MONOPINE/SHELTER

RAYCAP DC6-48-60-18-8C &
DC6-48-60-0-8C SURGE SUPPRESSION
SOLUTION
COLOR: BLACK/SILVER
DIMENSIONS: 11" DIA X 27" TALL W/ 9" BASE
WEIGHT: +/- 50 LBS. (INCLUDING MOUNTING HARDWARE)

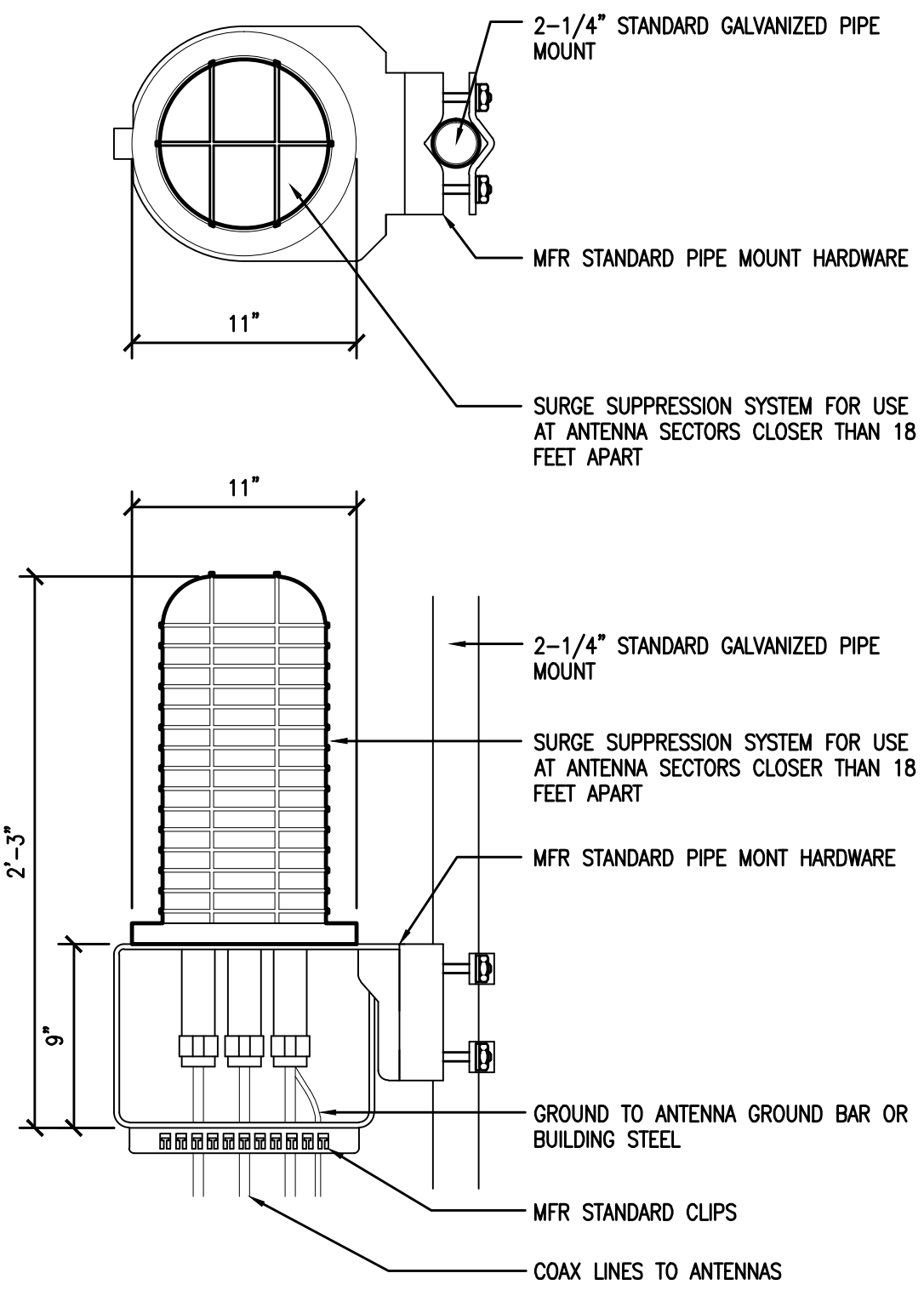

1 DC SURGE SUPPRESSION (SQUID)
1 1/2"=1'-0"

ERICSSON WCS RRU-32
MODEL: KRC161 423/1
COLOR: WHITE
DIMENSIONS: 29.9" TALL X 13.3" WIDE X 9.5" DEEP (INCLUDING SUNSHIELD)
WEIGHT: +/- 77LBS. (INCLUDING MOUNTING HARDWARE)

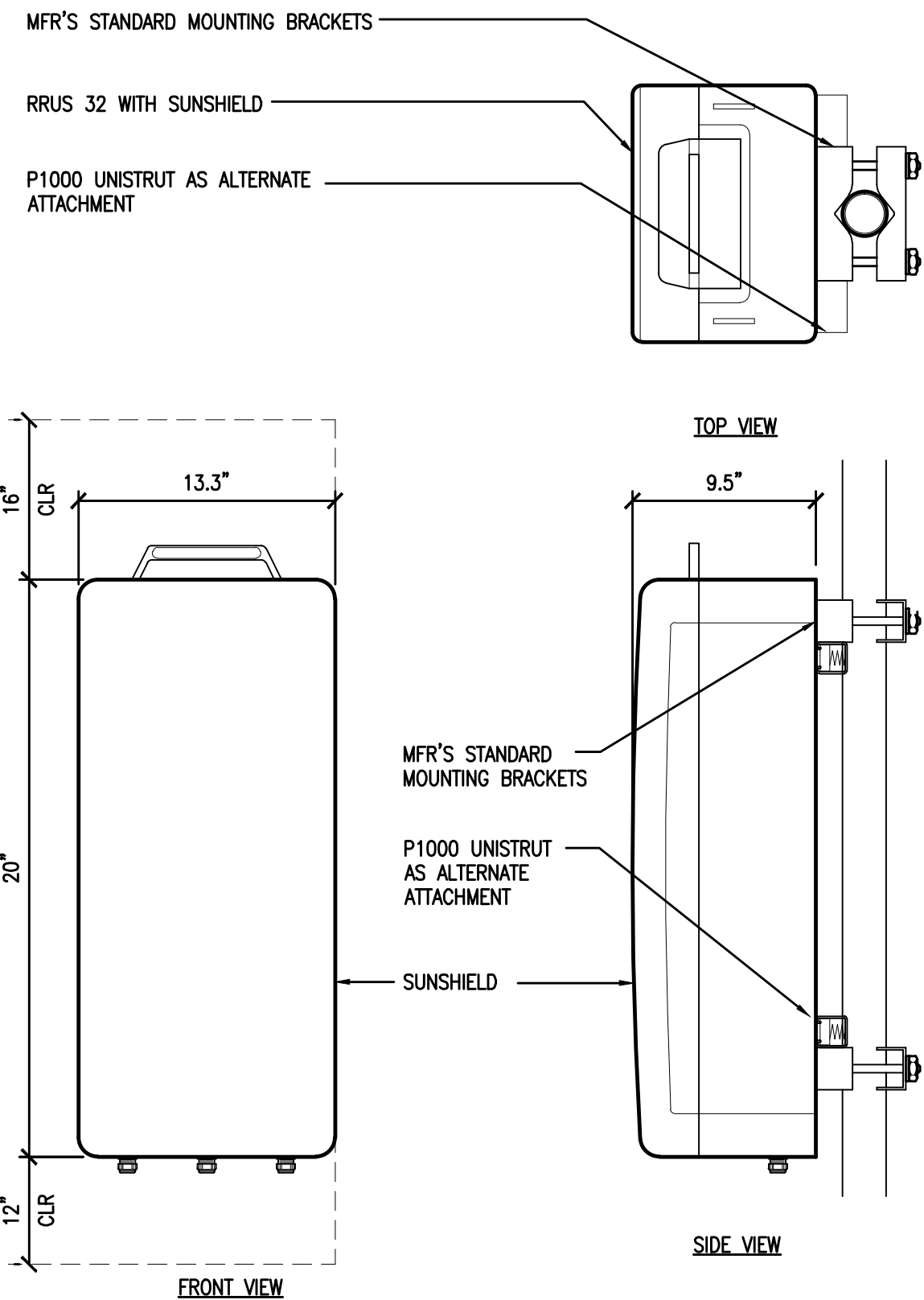

2 ERICSSON WCS RRUS-32 REMOTE RADIO UNIT
1 1/2"=1'-0"

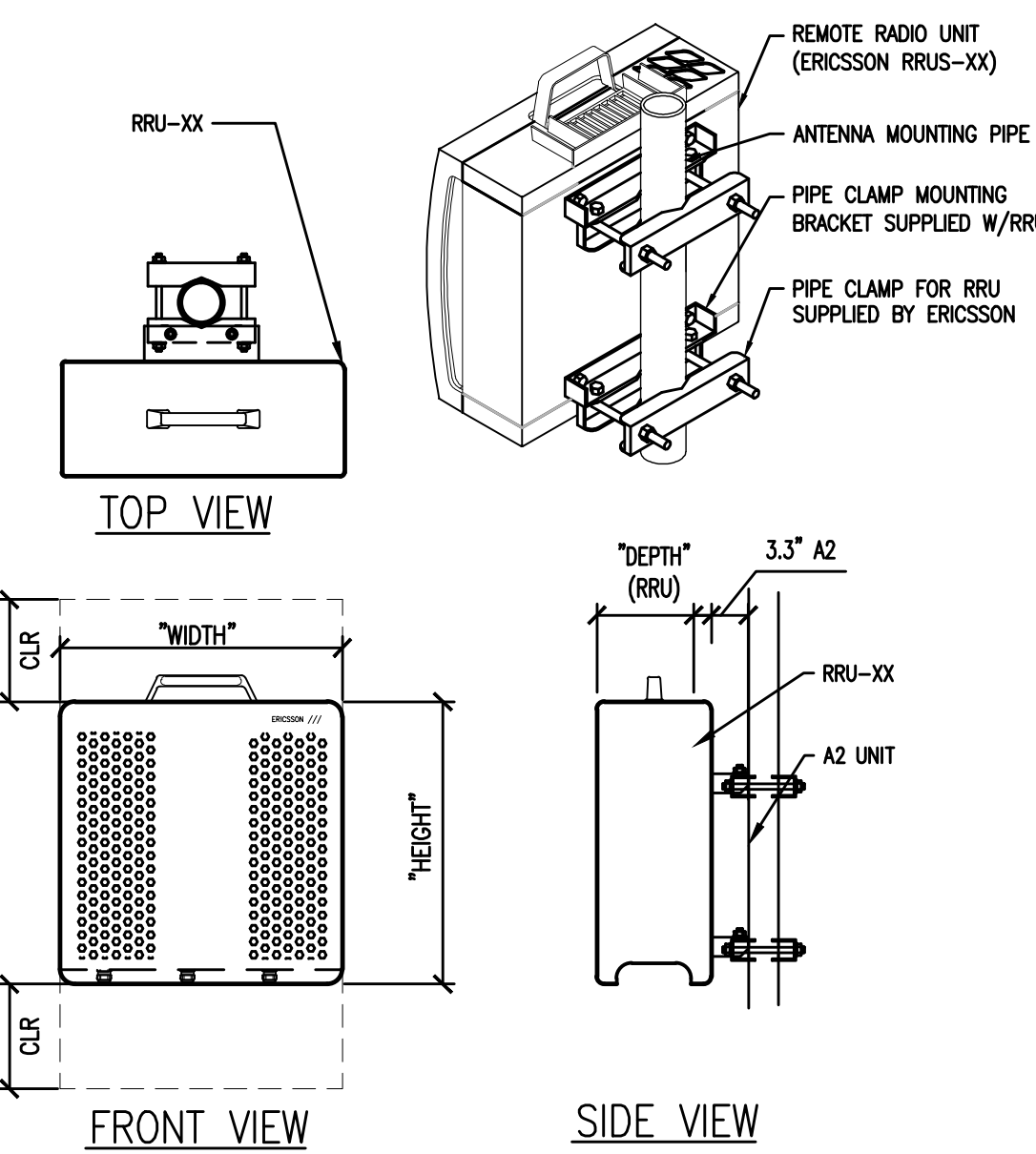

TYPE	HEIGHT	WIDTH	DEPTH	WEIGHT
RRUS-11	17.8"	17.3"	7.19"	50 LBS
RRUS-12	20.4"	18.5"	7.5"	57.5 LBS

3 ERICSSON RRU-XX REMOTE RADIO UNIT
1 1/2"=1'-0"

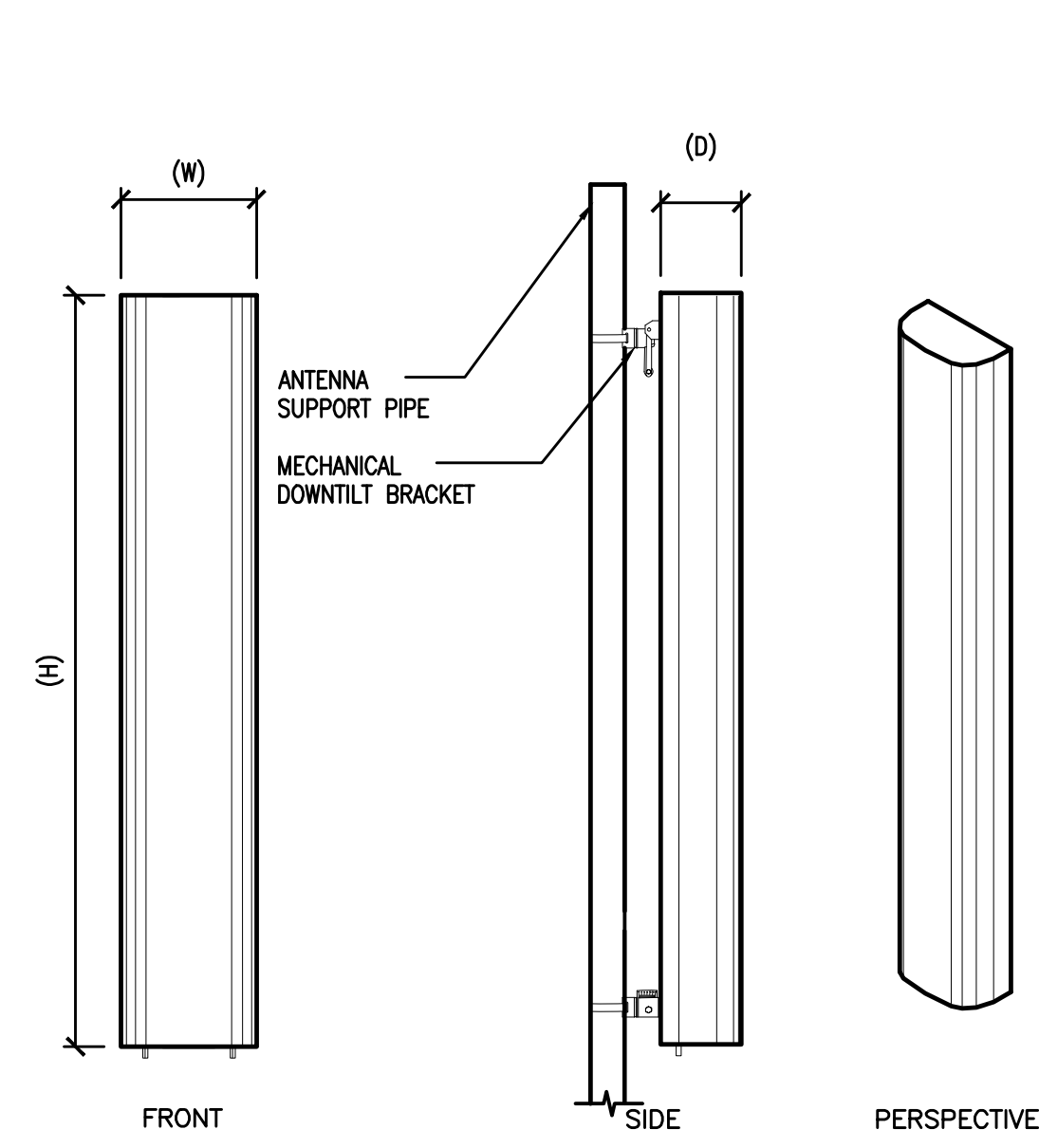

- ANTENNA = QUINTEL QS6656-3
WIND AREA = 6 SQ.FT.
WEIGHT = 65 LBS
DIMENSIONS = 72" (H) x 12" (W) x 9.6" (D)
- ANTENNA = QUINTEL QS6658-3
WIND AREA = 6 SQ.FT.
WEIGHT = 77 LBS
DIMENSIONS = 72" (H) x 12" (W) x 9.6" (D)
- ANTENNA = CCI HBSA-M65R-KU-H6
WIND AREA = 6.5 SQ.FT.
WEIGHT = 44.5 LBS
DIMENSIONS = 68.1" (H) x 13.7" (W) x 8.5" (D)
- ANTENNA = CCI HBSA-M65R-KU-H6
WIND AREA = 6.5 SQ.FT.
WEIGHT = 45.6 LBS
DIMENSIONS = 68.1" (H) x 13.7" (W) x 8.5" (D)

4 HEX ANTENNA SPEC
3/4"=1'-0"

RF SCHEDULE									
SECTOR	ANTENNA MODEL NO.	AZIMUTH	RAD CENTER	RRU	TMA	FIBER LENGTH	COAX LENGTH	FIBER NO.	
A L F A	A1	QS6656-3	30° ± 140'-0"	(1) RRUI1 (1) RRU32	N/A	± 170'	± N/A	TRUNK 1	
	A2	QS6658-3	30° ± 140'-0"	(2) RRUI1 (1) RRU32	N/A	± 170'	± N/A	TRUNK 1	
	A3	HBSA-M65R-KU-H6	30° ± 150'-0"	(1) RRU32	N/A	± 180'	± N/A	TRUNK 4	
	A4	HBSA-M65R-KU-H6	30° ± 150'-0"	(1) RRU32	N/A	± 180'	± N/A	TRUNK 4	
B E T A	B1	QS6656-3	270° ± 140'-0"	(1) RRUI1 (1) RRU32	N/A	± 170'	± N/A	TRUNK 2	
	B2	QS6658-3	270° ± 140'-0"	(2) RRUI1 (1) RRU32	N/A	± 170'	± N/A	TRUNK 2	
	B3	HBSA-M65R-KU-H6	270° ± 150'-0"	(1) RRU32	N/A	± 180'	± N/A	TRUNK 4	
	B4	HBSA-M65R-KU-H6	270° ± 150'-0"	(1) RRU32	N/A	± 180'	± N/A	TRUNK 4	
G A M M A	C1	QS6656-3	150° ± 140'-0"	(1) RRUI1 (1) RRU32	N/A	± 170'	± N/A	TRUNK 3	
	C2	QS6658-3	150° ± 140'-0"	(2) RRUI1 (1) RRU32	N/A	± 170'	± N/A	TRUNK 3	
	C3	HBSA-M65R-KU-H6	150° ± 150'-0"	(1) RRU32	N/A	± 180'	± N/A	TRUNK 4	
	C4	HBSA-M65R-KU-H6	150° ± 150'-0"	(1) RRU32	N/A	± 180'	± N/A	TRUNK 4	

5 RF SCHEDULE
NOT TO SCALE

RF DATA SHEET v1.00.01 DATED 05/16/17

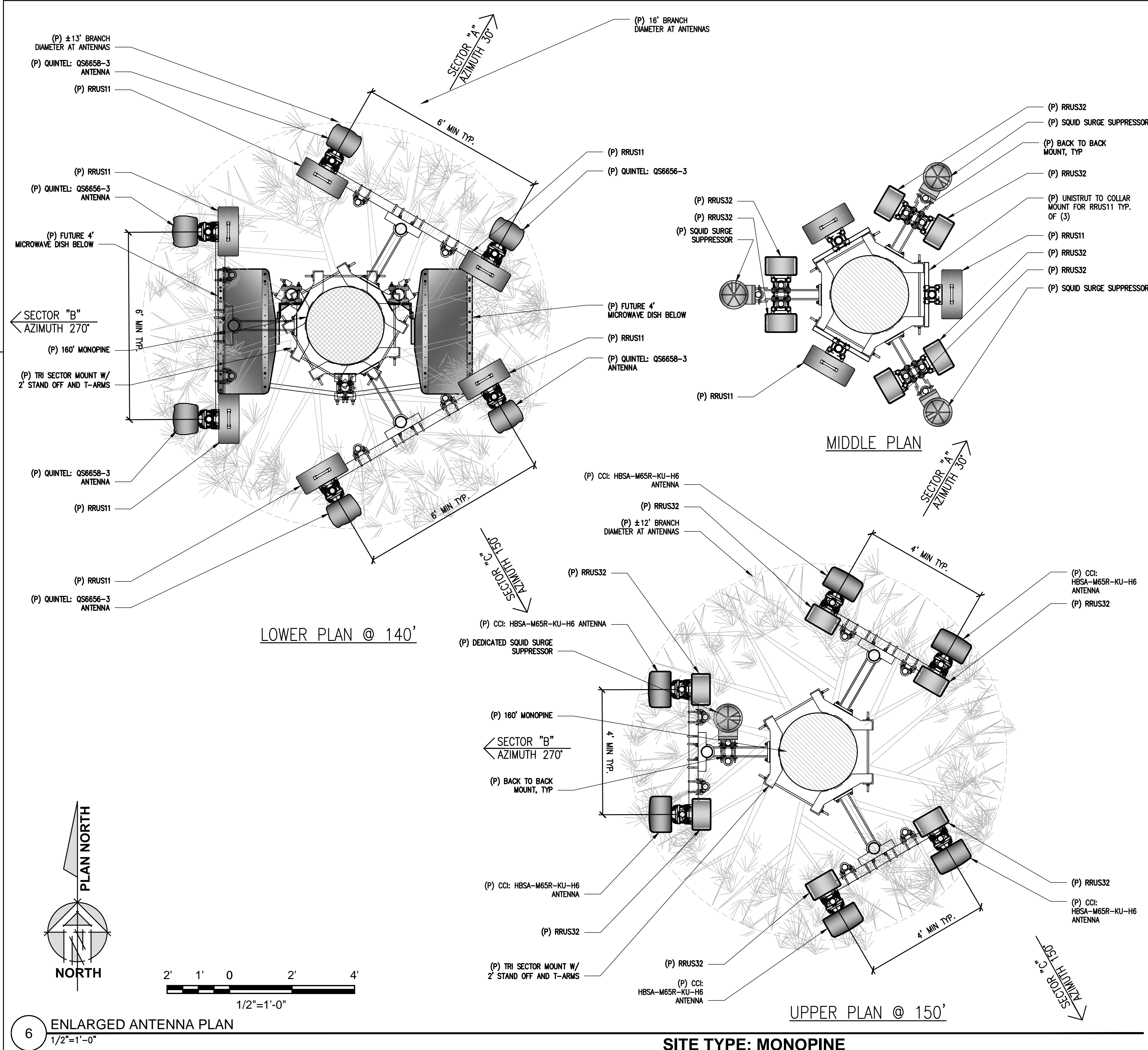

6 ENLARGED ANTENNA PLAN
1/2"=1'-0"

SITE TYPE: MONOPINE

Issued For:
PLEASANT VALLEY
4559 STRAUSS DRIVE
PLACERVILLE, CA 95667

PREPARED FOR
at&t
2600 Camino Ramon, 4W850 N
San Ramon, California 94583

EPIC
WIRELESS GROUP

AT&T SITE NO: CVL03180
PROJECT NO: 13787610
DRAWN BY: CES
CHECKED BY: CES

REV	DATE	DESCRIPTION
0	07/05/17	ZD 90%
1	08/03/17	ZD 100% SHELTER CHANGE

Licensor:
CRAIG M. HORNER
No. 84674
REGISTERED PROFESSIONAL ENGINEER
STATE OF CALIFORNIA
CIVIL

IT IS A VIOLATION OF LAW FOR ANY PERSON, UNLESS THEY ARE ACTING UNDER THE DIRECTION OF A LICENSED PROFESSIONAL ENGINEER, TO ALTER THIS DOCUMENT.

Engineer:
ADAPTIVE RE-USE ENGINEERING
Craig Horner, PE 84674
214-407-3184
3112 LEATHA WAY
SACRAMENTO, CA 95821
craigmhorner@yahoo.com

SHEET TITLE:
ANTENNA PLAN & DETAILS

SHEET NUMBER:
A-3

- (P) TOP OF MONOPINE BRANCHES
± EL. 160' AGL
- (P) TOP OF MONOPINE STEEL
± EL. 153' AGL
- (P) AT&T ANTENNA RAD CENTER
± EL. 150' AGL
- (P) AT&T ANTENNA RAD CENTER
± EL. 140' AGL
- (P) FUTURE AT&T MICROWAVE CENTER LINE
± EL. 132.5' AGL
- (P) FUTURE CARRIER RAD CENTER
± EL. 125' AGL
- (P) FUTURE CARRIER RAD CENTER
± EL. 110' AGL

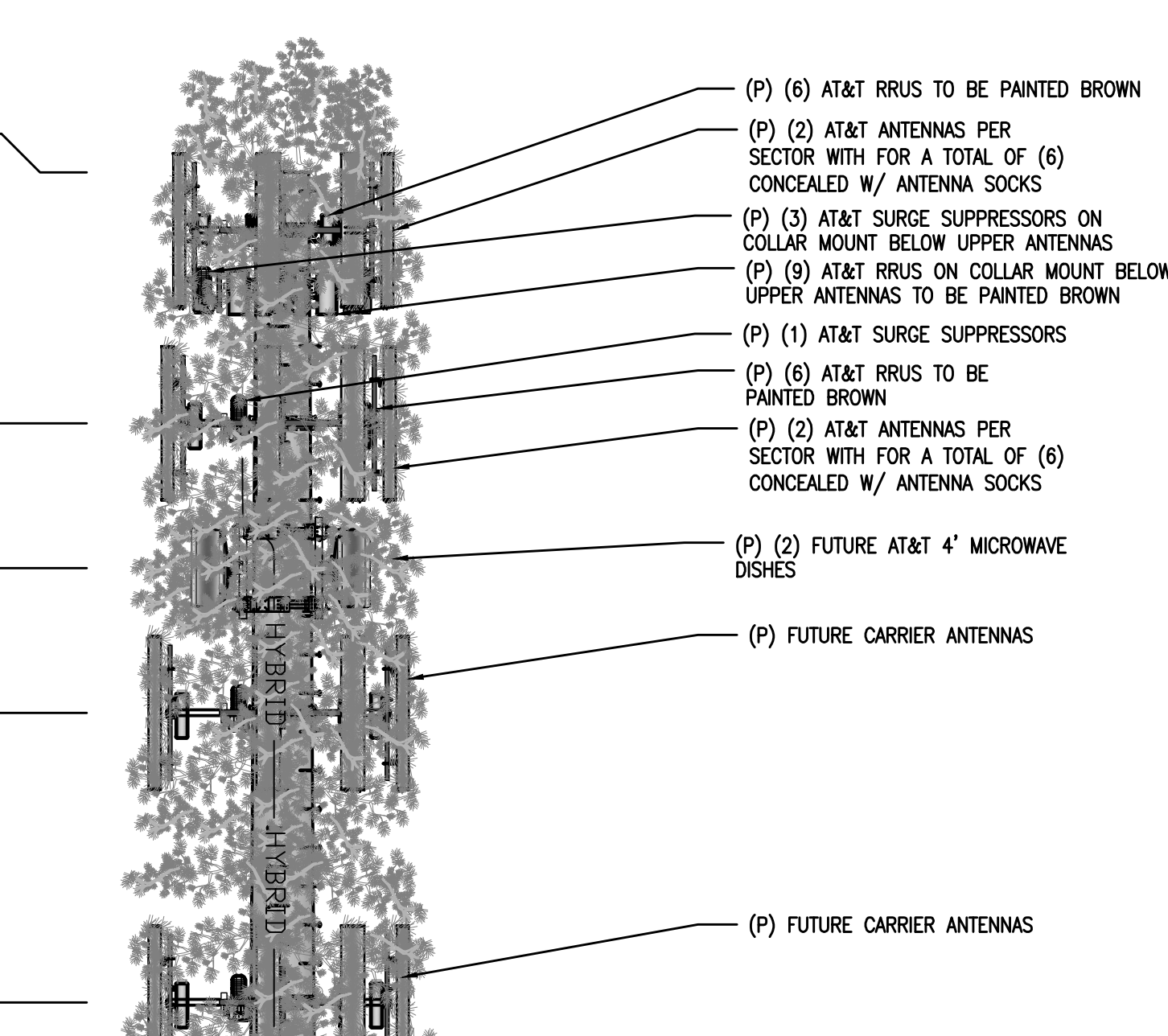

- (P) (6) AT&T RRUS TO BE PAINTED BROWN
- (P) (2) AT&T ANTENNAS PER SECTOR WITH FOR A TOTAL OF (6) CONCEALED W/ ANTENNA SOCKS
- (P) (3) AT&T SURGE SUPPRESSORS ON COLLAR MOUNT BELOW UPPER ANTENNAS
- (P) (9) AT&T RRUS ON COLLAR MOUNT BELOW UPPER ANTENNAS TO BE PAINTED BROWN
- (P) (1) AT&T SURGE SUPPRESSORS
- (P) (6) AT&T RRUS TO BE PAINTED BROWN
- (P) (2) AT&T ANTENNAS PER SECTOR WITH FOR A TOTAL OF (6) CONCEALED W/ ANTENNA SOCKS
- (P) (2) FUTURE AT&T 4' MICROWAVE DISHES
- (P) FUTURE CARRIER ANTENNAS
- (P) FUTURE CARRIER ANTENNAS

NOTE:
BRANCHES SHOWN ARE FOR
ILLUSTRATIVE PURPOSES ONLY.
NOT TO SCALE

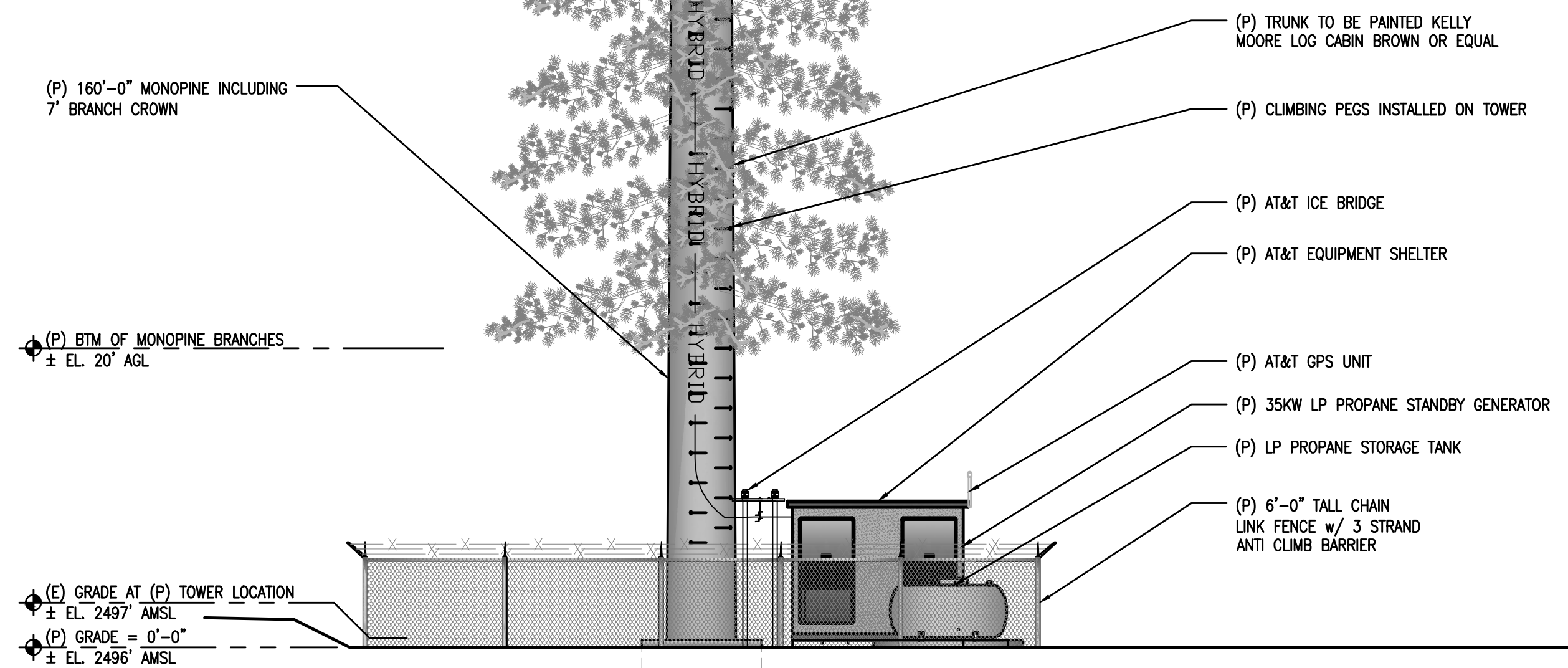

- (P) TRUNK TO BE PAINTED KELLY MOORE LOG CABIN BROWN OR EQUAL
- (P) CLIMBING PEGS INSTALLED ON TOWER
- (P) AT&T ICE BRIDGE
- (P) AT&T EQUIPMENT SHELTER
- (P) AT&T GPS UNIT
- (P) 35KW LP PROPANE STANDBY GENERATOR
- (P) LP PROPANE STORAGE TANK
- (P) 6'-0" TALL CHAIN LINK FENCE w/ 3 STRAND ANTI CLIMB BARRIER

- (E) GRADE AT (P) TOWER LOCATION
± EL. 2497' AMSL
- (P) GRADE = 0'-0"
± EL. 2496' AMSL

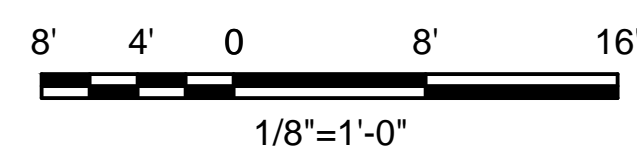

1 PROPOSED NORTH ELEVATION
1/8"=1'-0"

- (P) TOP OF MONOPINE BRANCHES
± EL. 160' AGL
- (P) TOP OF MONOPINE STEEL
± EL. 153' AGL
- (P) AT&T ANTENNA RAD CENTER = 150'-0"
± EL. 150' AGL
- (P) AT&T ANTENNA RAD CENTER
± EL. 140' AGL
- (P) FUTURE AT&T MICROWAVE CENTER LINE
± EL. 132.5' AGL
- (P) FUTURE CARRIER RAD CENTER
± EL. 125' AGL
- (P) FUTURE CARRIER RAD CENTER
± EL. 110' AGL

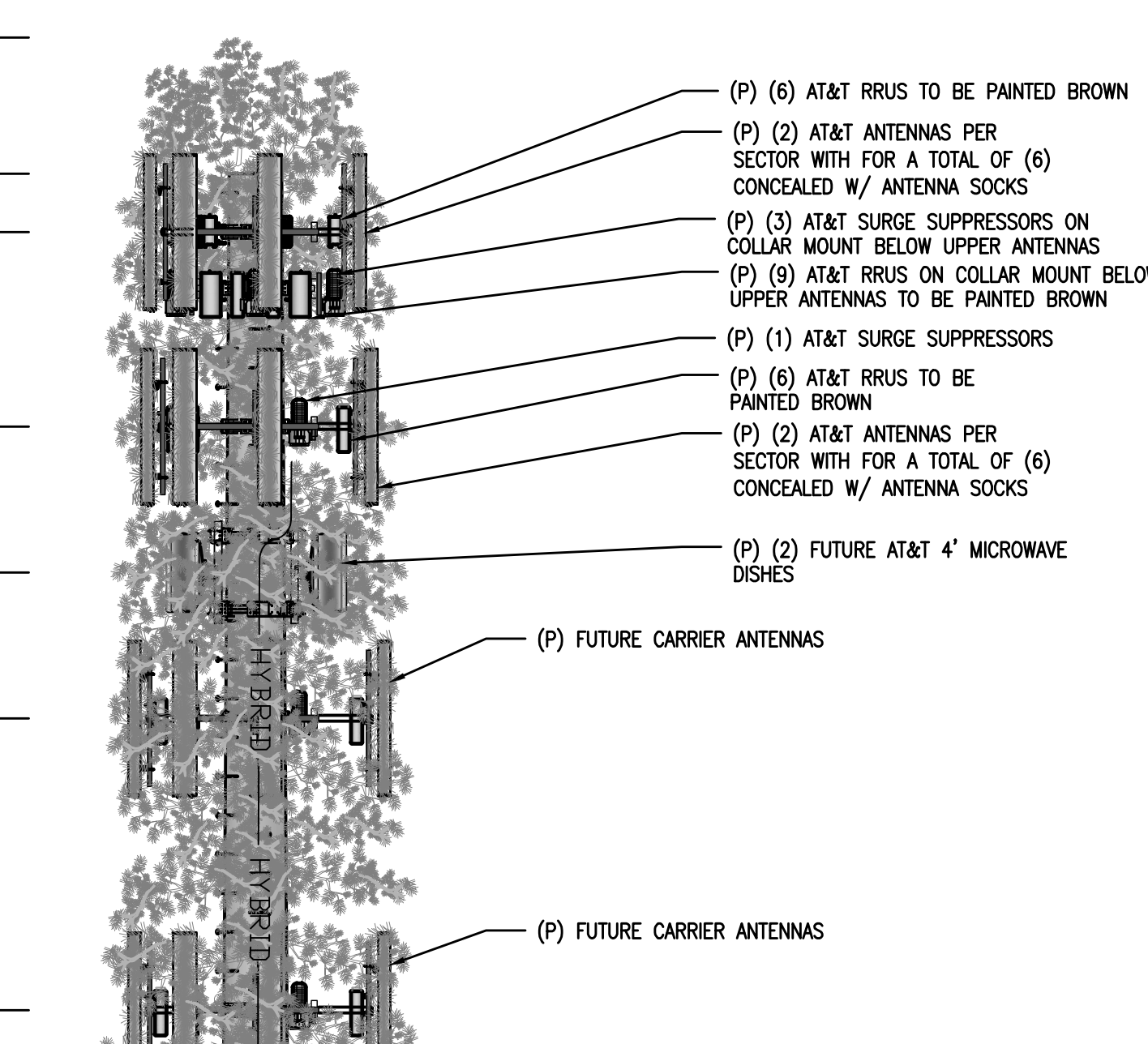

- (P) (6) AT&T RRUS TO BE PAINTED BROWN
- (P) (2) AT&T ANTENNAS PER SECTOR WITH FOR A TOTAL OF (6) CONCEALED W/ ANTENNA SOCKS
- (P) (3) AT&T SURGE SUPPRESSORS ON COLLAR MOUNT BELOW UPPER ANTENNAS
- (P) (9) AT&T RRUS ON COLLAR MOUNT BELOW UPPER ANTENNAS TO BE PAINTED BROWN
- (P) (1) AT&T SURGE SUPPRESSORS
- (P) (6) AT&T RRUS TO BE PAINTED BROWN
- (P) (2) AT&T ANTENNAS PER SECTOR WITH FOR A TOTAL OF (6) CONCEALED W/ ANTENNA SOCKS
- (P) (2) FUTURE AT&T 4' MICROWAVE DISHES
- (P) FUTURE CARRIER ANTENNAS
- (P) FUTURE CARRIER ANTENNAS

NOTE:
BRANCHES SHOWN ARE FOR
ILLUSTRATIVE PURPOSES ONLY.
NOT TO SCALE

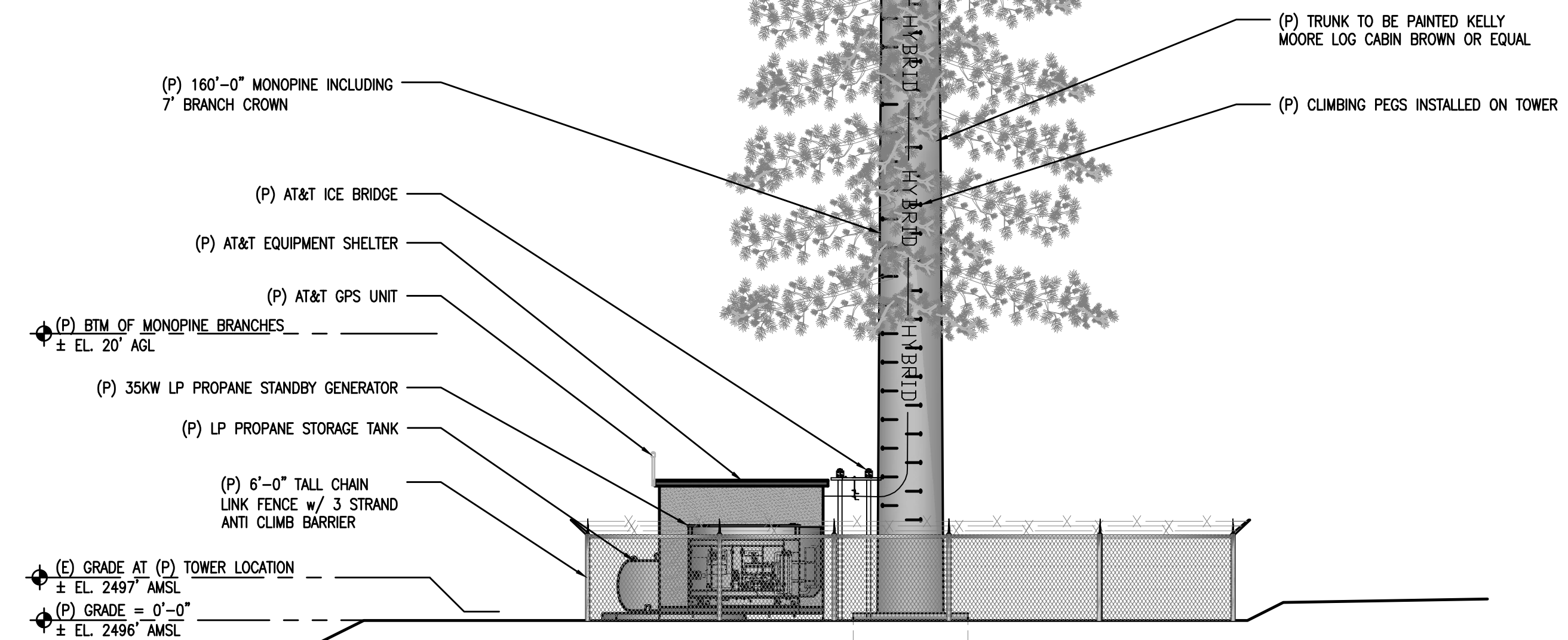

- (P) TRUNK TO BE PAINTED KELLY MOORE LOG CABIN BROWN OR EQUAL
- (P) CLIMBING PEGS INSTALLED ON TOWER
- (P) AT&T ICE BRIDGE
- (P) AT&T EQUIPMENT SHELTER
- (P) AT&T GPS UNIT
- (P) 35KW LP PROPANE STANDBY GENERATOR
- (P) LP PROPANE STORAGE TANK
- (P) 6'-0" TALL CHAIN LINK FENCE w/ 3 STRAND ANTI CLIMB BARRIER

- (E) GRADE AT (P) TOWER LOCATION
± EL. 2497' AMSL
- (P) GRADE = 0'-0"
± EL. 2496' AMSL

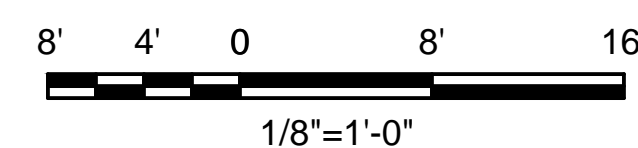

2 PROPOSED SOUTH ELEVATION
1/8"=1'-0"

SITE TYPE: MONOPINE/SHELTER

Issued For:
PLEASANT VALLEY
4559 STRAUSS DRIVE
PLACERVILLE, CA 95667

PREPARED FOR

2600 Camino Ramon, 4W850 N
San Ramon, California 94583

WIRELESS GROUP

AT&T SITE NO: CVL03180
PROJECT NO: 13787610
DRAWN BY: CES
CHECKED BY: CES

REV	DATE	DESCRIPTION
0	07/05/17	ZD 90%
1	08/03/17	ZD 100% SHELTER CHANGE

Licensors:

REGISTERED PROFESSIONAL ENGINEER
No. 84674
CIVIL
STATE OF CALIFORNIA

IT IS A VIOLATION OF LAW FOR ANY PERSON, UNLESS THEY ARE ACTING UNDER THE DIRECTION OF A LICENSED PROFESSIONAL ENGINEER, TO ALTER THIS DOCUMENT.

Engineer:
ADAPTIVE RE-USE ENGINEERING
Craig Horner, PE 84674
214-407-3184
3112 LEATHA WAY
SACRAMENTO, CA 95821
craigmhorner@yahoo.com

SHEET TITLE:
PROPOSED MONOPINE
NORTH - SOUTH ELEVATION

SHEET NUMBER:
A-4.1

- (P) TOP OF MONOPINE BRANCHES
± EL. 160' AGL
- (P) TOP OF MONOPINE STEEL
± EL. 153' AGL
- (P) AT&T ANTENNA RAD. CENTER
± EL. 150' AGL
- (P) AT&T ANTENNA RAD. CENTER
± EL. 140' AGL
- (P) FUTURE AT&T MICROWAVE CENTER LINE
± EL. 132.5' AGL
- (P) FUTURE CARRIER RAD CENTER
± EL. 125' AGL
- (P) FUTURE CARRIER RAD CENTER
± EL. 110' AGL

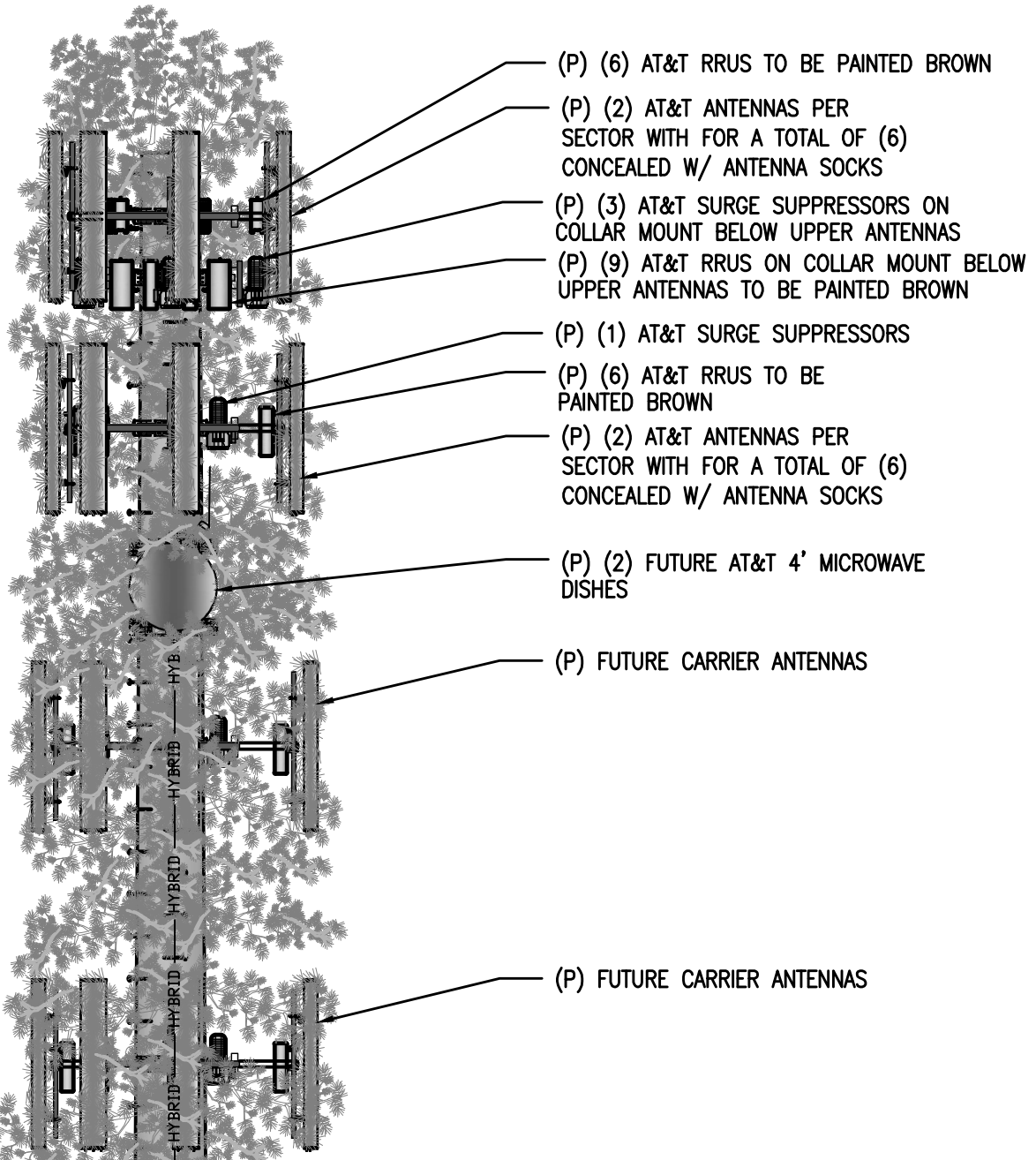

- (P) (6) AT&T RRUS TO BE PAINTED BROWN
- (P) (2) AT&T ANTENNAS PER SECTOR WITH FOR A TOTAL OF (6) CONCEALED W/ ANTENNA SOCKS
- (P) (3) AT&T SURGE SUPPRESSORS ON COLLAR MOUNT BELOW UPPER ANTENNAS
- (P) (9) AT&T RRUS ON COLLAR MOUNT BELOW UPPER ANTENNAS TO BE PAINTED BROWN
- (P) (1) AT&T SURGE SUPPRESSORS
- (P) (6) AT&T RRUS TO BE PAINTED BROWN
- (P) (2) AT&T ANTENNAS PER SECTOR WITH FOR A TOTAL OF (6) CONCEALED W/ ANTENNA SOCKS
- (P) (2) FUTURE AT&T 4' MICROWAVE DISHES
- (P) FUTURE CARRIER ANTENNAS
- (P) FUTURE CARRIER ANTENNAS

NOTE:
BRANCHES SHOWN ARE FOR
ILLUSTRATIVE PURPOSES ONLY.
NOT TO SCALE

- (P) 160'-0" MONOPINE INCLUDING 7' BRANCH CROWN
- (P) AT&T ICE BRIDGE
- (P) AT&T EQUIPMENT SHELTER
- (P) TRUNK TO BE PAINTED KELLY MOORE LOG CABIN BROWN OR EQUAL
- (P) CLIMBING PEGS INSTALLED ON TOWER
- (P) AT&T GPS UNIT
- (P) LP PROPANE STORAGE TANK
- (P) 6'-0" TALL CHAIN LINK FENCE w/ 3 STRAND ANTI CLIMB BARRIER
- (P) BTM OF MONOPINE BRANCHES
± EL. 20' AGL
- (P) 35KW LP PROPANE STANDBY GENERATOR
- (P) AT&T GPS UNIT
- (P) LP PROPANE STORAGE TANK
- (P) 6'-0" TALL CHAIN LINK FENCE w/ 3 STRAND ANTI CLIMB BARRIER
- (E) GRADE AT (P) TOWER LOCATION
± EL. 2497' AMSL
- (P) GRADE = 0'-0"
± EL. 2496' AMSL
- (P) TOWER MATT SLAB (DESIGN BY OTHERS)

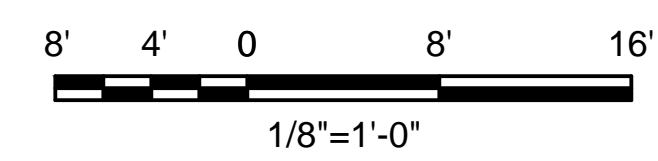

1 PROPOSED EAST ELEVATION
1/8"=1'-0"

- (P) TOP OF MONOPINE BRANCHES
± EL. 160' AGL
- (P) TOP OF MONOPINE STEEL
± EL. 153' AGL
- (P) AT&T ANTENNA RAD. CENTER
± EL. 150' AGL
- (P) AT&T ANTENNA RAD. CENTER
± EL. 140' AGL
- (P) FUTURE AT&T MICROWAVE CENTER LINE
± EL. 132.5' AGL
- (P) FUTURE CARRIER RAD CENTER
± EL. 125' AGL
- (P) FUTURE CARRIER RAD CENTER
± EL. 110' AGL

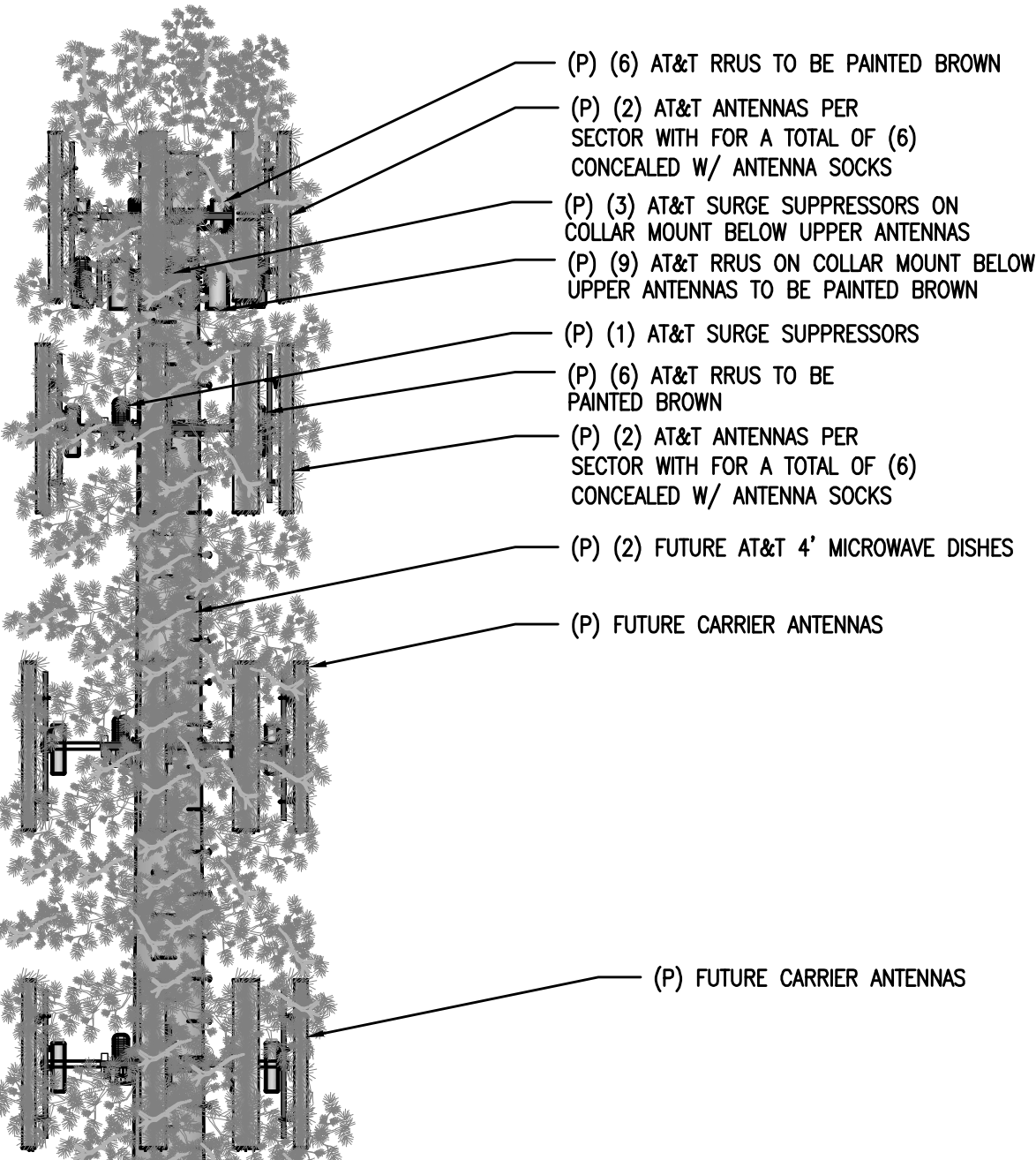

- (P) (6) AT&T RRUS TO BE PAINTED BROWN
- (P) (2) AT&T ANTENNAS PER SECTOR WITH FOR A TOTAL OF (6) CONCEALED W/ ANTENNA SOCKS
- (P) (3) AT&T SURGE SUPPRESSORS ON COLLAR MOUNT BELOW UPPER ANTENNAS
- (P) (9) AT&T RRUS ON COLLAR MOUNT BELOW UPPER ANTENNAS TO BE PAINTED BROWN
- (P) (1) AT&T SURGE SUPPRESSORS
- (P) (6) AT&T RRUS TO BE PAINTED BROWN
- (P) (2) AT&T ANTENNAS PER SECTOR WITH FOR A TOTAL OF (6) CONCEALED W/ ANTENNA SOCKS
- (P) (2) FUTURE AT&T 4' MICROWAVE DISHES
- (P) FUTURE CARRIER ANTENNAS
- (P) FUTURE CARRIER ANTENNAS

NOTE:
BRANCHES SHOWN ARE FOR
ILLUSTRATIVE PURPOSES ONLY.
NOT TO SCALE

- (P) 160'-0" MONOPINE INCLUDING 7' BRANCH CROWN
- (P) AT&T ICE BRIDGE
- (P) AT&T EQUIPMENT SHELTER
- (P) TRUNK TO BE PAINTED KELLY MOORE LOG CABIN BROWN OR EQUAL
- (P) CLIMBING PEGS INSTALLED ON TOWER
- (P) AT&T GPS UNIT
- (P) LP PROPANE STORAGE TANK
- (P) 6'-0" TALL CHAIN LINK FENCE w/ 3 STRAND ANTI CLIMB BARRIER
- (P) BTM OF MONOPINE BRANCHES
± EL. 20' AGL
- (P) 35KW LP PROPANE STANDBY GENERATOR
- (P) AT&T GPS UNIT
- (P) LP PROPANE STORAGE TANK
- (P) 6'-0" TALL CHAIN LINK FENCE w/ 3 STRAND ANTI CLIMB BARRIER
- (E) GRADE AT (P) TOWER LOCATION
± EL. 2497' AMSL
- (P) GRADE = 0'-0"
± EL. 2496' AMSL
- (P) TOWER MATT SLAB (DESIGN BY OTHERS)

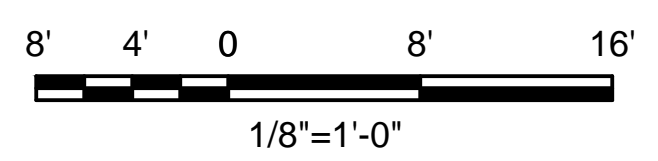

2 PROPOSED WEST ELEVATION
1/8"=1'-0"

SITE TYPE: MONOPINE/SHELTER

Issued For:
PLEASANT VALLEY
4559 STRAUSS DRIVE
PLACERVILLE, CA 95667

PREPARED FOR

2600 Camino Ramon, 4W850 N
San Ramon, California 94583

WIRELESS GROUP

AT&T SITE NO: CVL03180
PROJECT NO: 13787610
DRAWN BY: CES
CHECKED BY: CES

REV	DATE	DESCRIPTION
0	07/05/17	ZD 90%
1	08/03/17	ZD 100% SHELTER CHANGE

Licensors:

IT IS A VIOLATION OF LAW FOR ANY PERSON, UNLESS THEY ARE ACTING UNDER THE DIRECTION OF A LICENSED PROFESSIONAL ENGINEER, TO ALTER THIS DOCUMENT.

Engineer:
ADAPTIVE RE-USE ENGINEERING
Craig Horner, PE 84674
214-407-3184
3112 LEATHA WAY
SACRAMENTO, CA 95821
craighorner@yahoo.com

SHEET TITLE:
PROPOSED MONOPINE WEST - EAST ELEVATION

SHEET NUMBER:
A-4.2

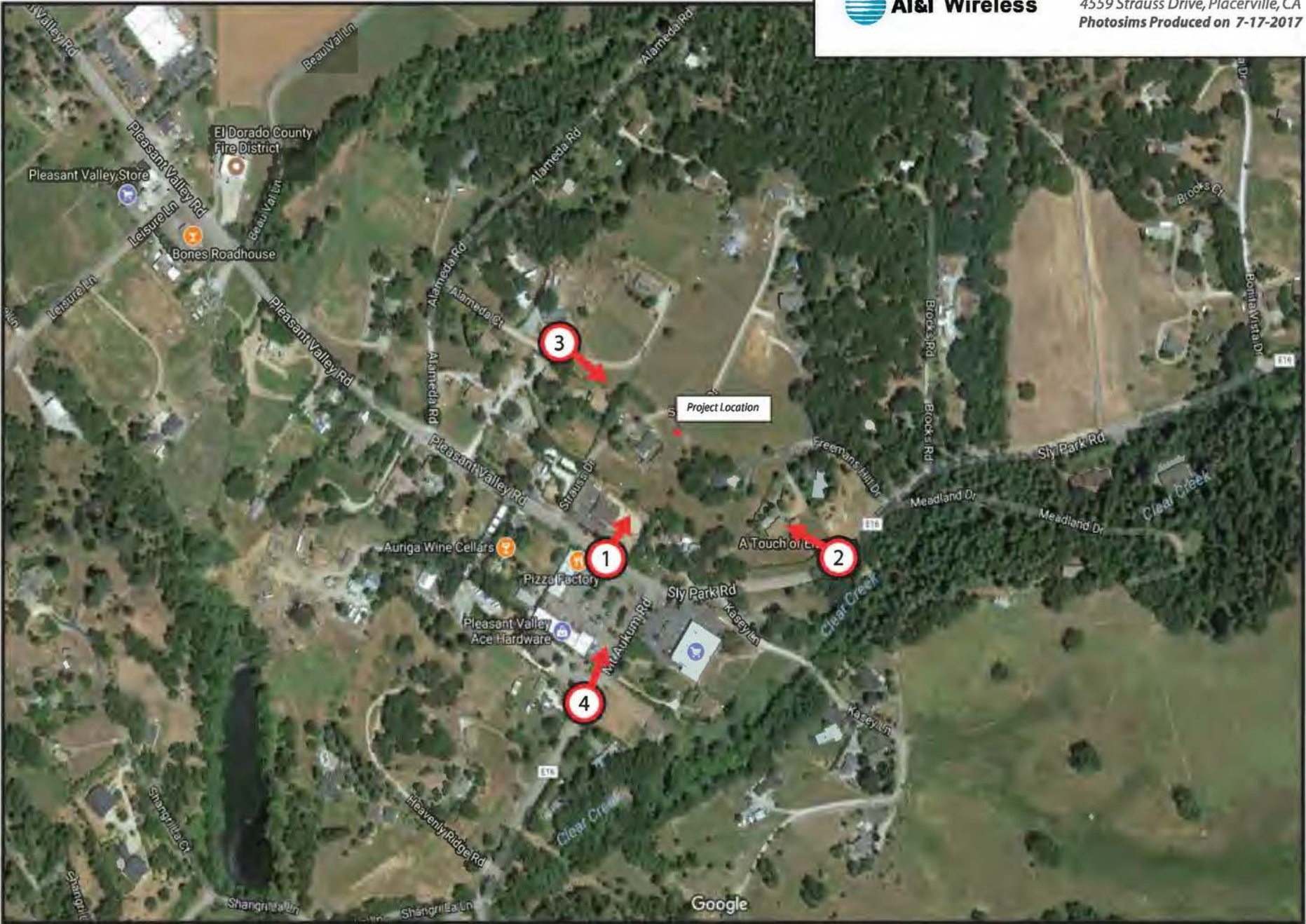

Exhibit G
Site 3 Pleasant Valley

Existing



Proposed



view from Pleasant Valley Road looking northeast at site



CVL03180 Pleasant Valley
4559 Strauss Drive, Placerville, CA
Photosims Produced on 7-17-2017

Existing



Proposed



view from Sly Park Road looking northwest at site



CVL03180 Pleasant Valley
4559 Strauss Drive, Placerville, CA
Photosims Produced on 7-17-2017

Existing



Proposed



view from Alameda Court looking southeast at site



CVL03180 Pleasant Valley
4559 Strauss Drive, Placerville, CA
Photosims Produced on 7-17-2017

Existing



Proposed

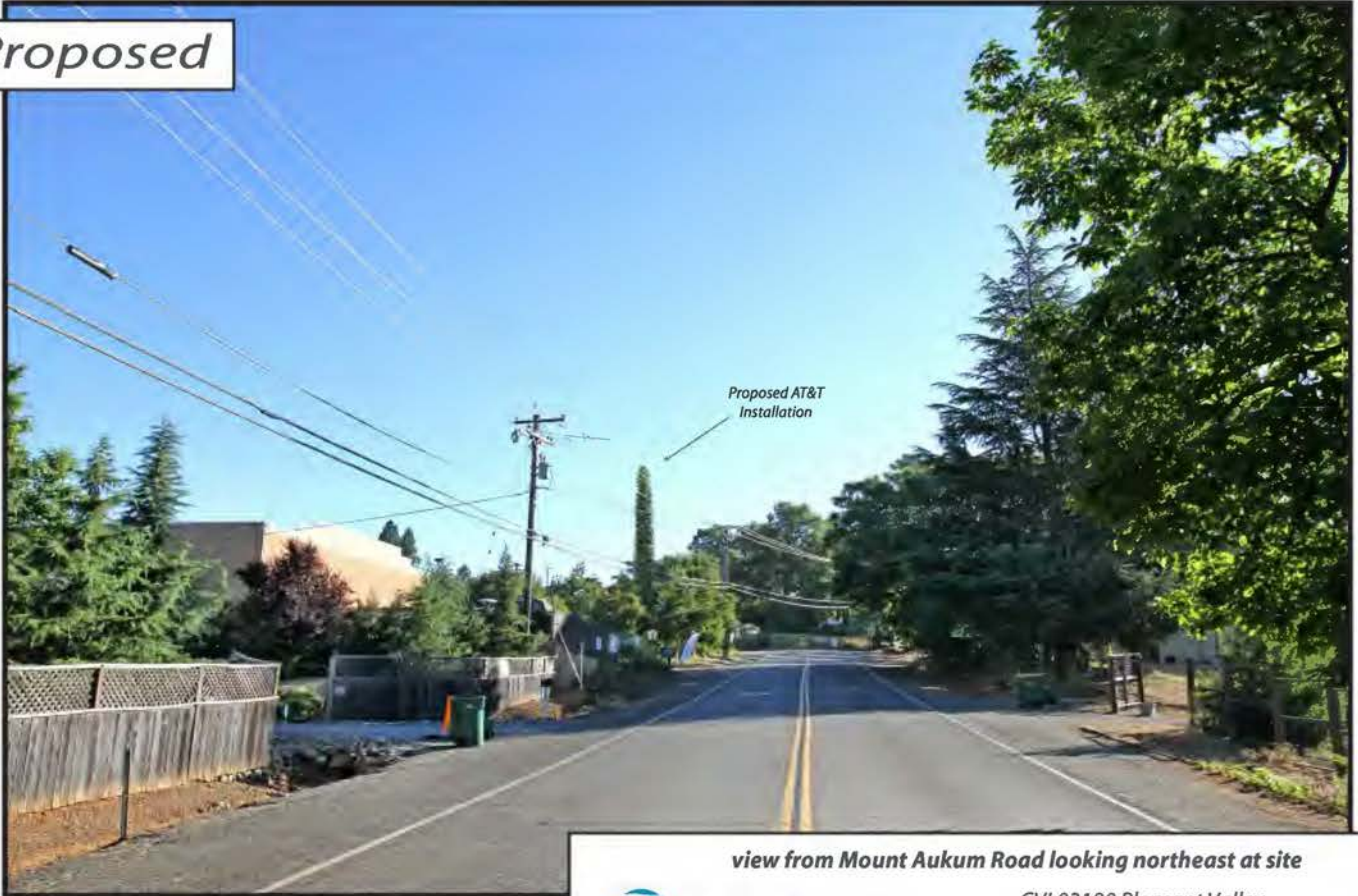

view from Mount Aukum Road looking northeast at site



CVL03180 Pleasant Valley
4559 Strauss Drive, Placerville, CA
Photosims Produced on 7-17-2017

CVL03180 Zoning Propagation Map

July 24th , 2017

Exhibit H
Site 3 Pleasant Valley



Street View With Existing and Proposed Site

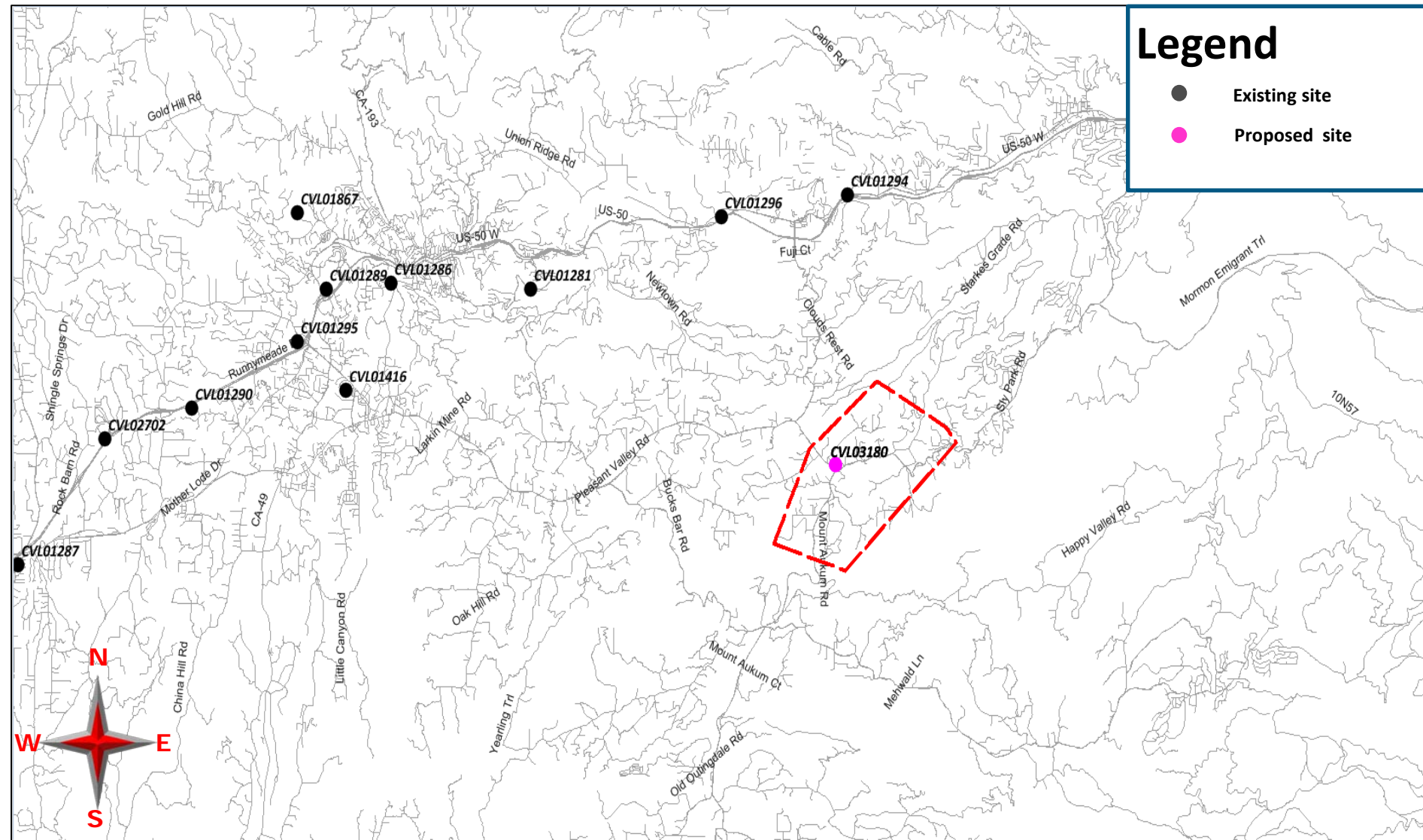



Existing LTE 700 Coverage

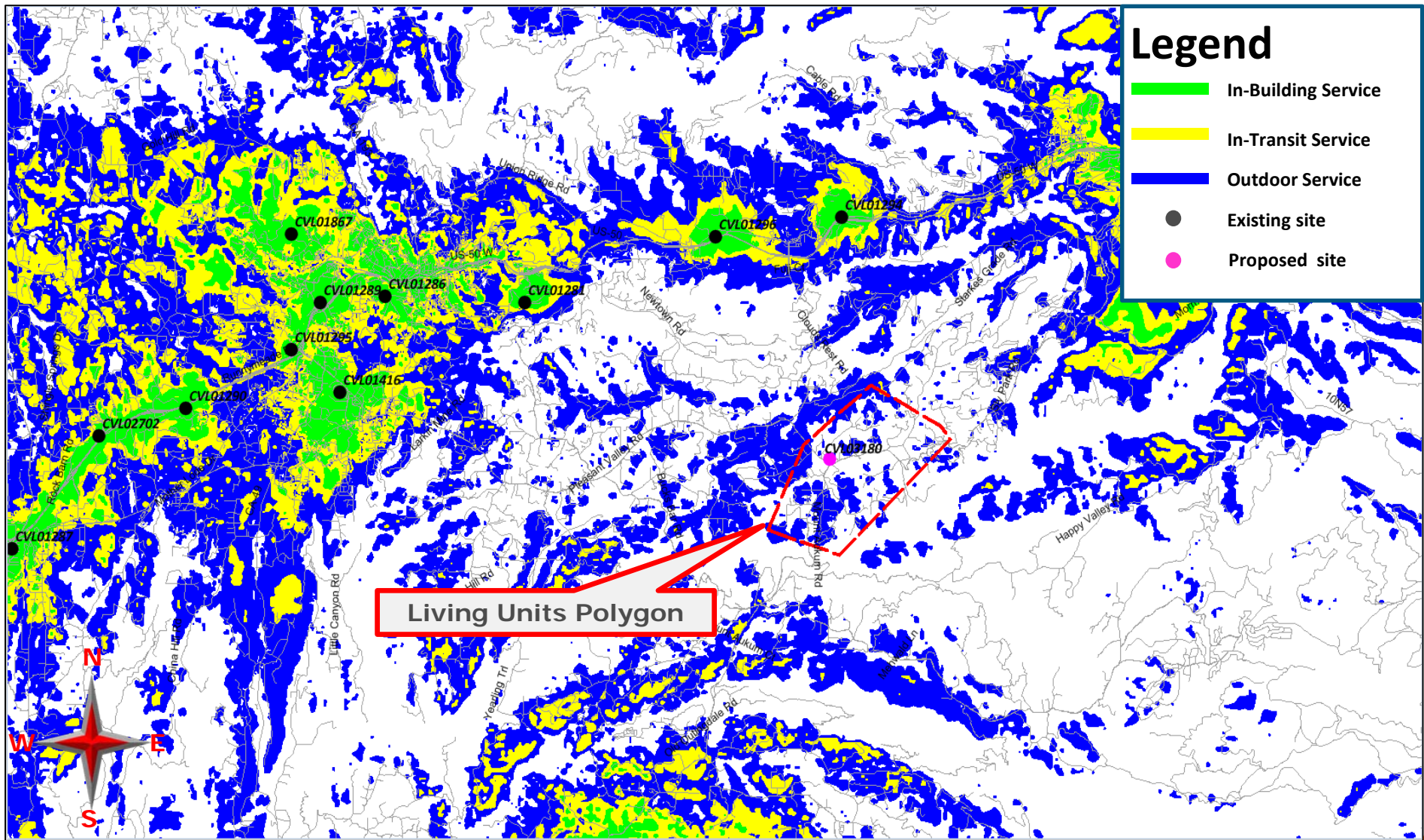



Existing LTE 700 Coverage With CVL03180 @ RC – 150ft Supports 255 LU's

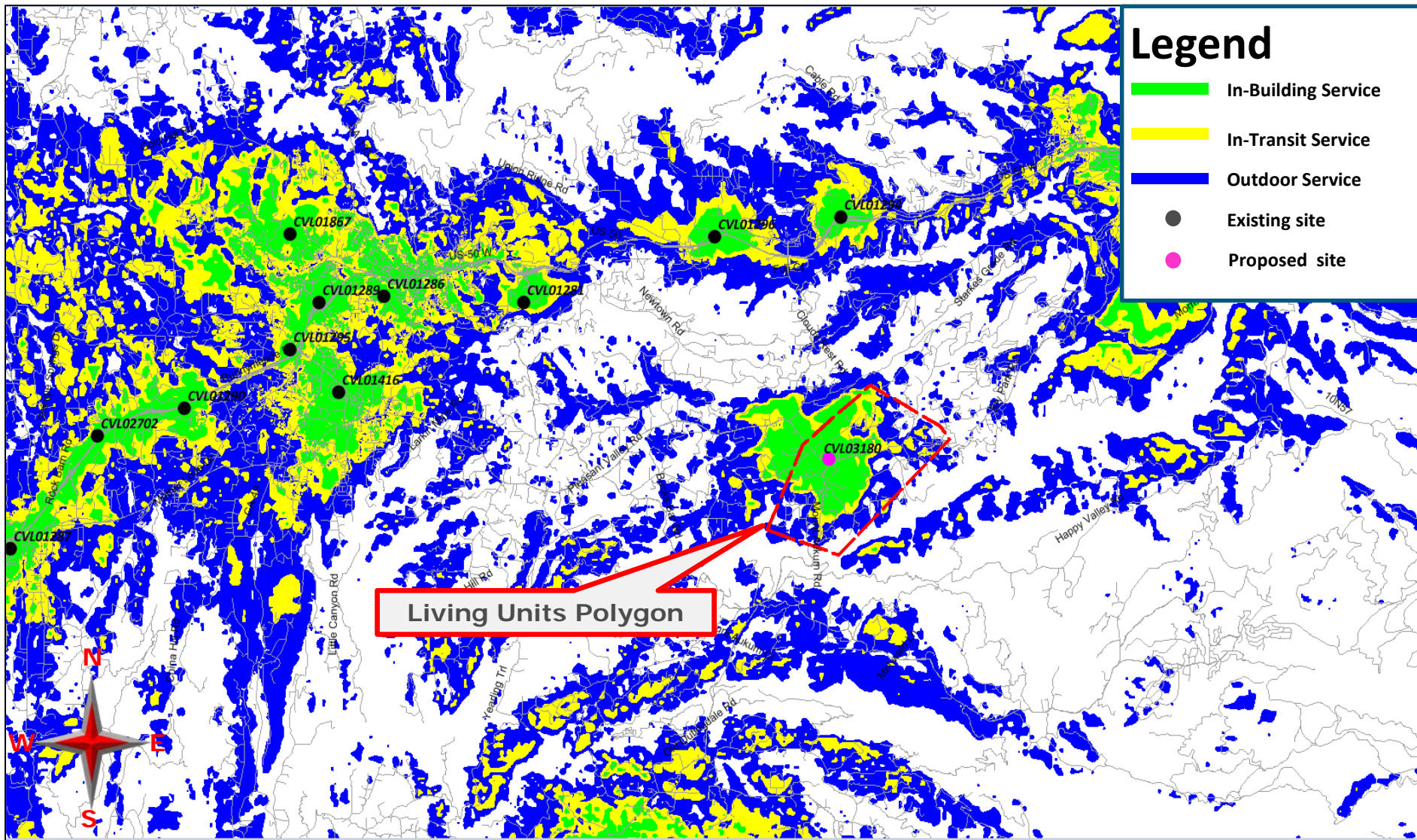



Radio Frequency Emissions Compliance Report For AT&T Mobility

Site Name:	Pleasant Valley-C	Site Structure Type:	Monopine
Address:	4559 Strauss Drive	Latitude:	38.68417
	Placerville, CA	Longitude:	-120.661996
Report Date:	July 21, 2017	Project:	New Build

General Summary

AT&T Mobility has contracted Waterford Consultants, LLC to conduct a Radio Frequency Electromagnetic Compliance assessment of the proposed Pleasant Valley-C site located at 4559 Strauss Drive, Placerville, CA. This report contains information about the radio telecommunications equipment to be installed at this site and the surrounding environment with regard to RF Hazard compliance. This assessment is based on installation designs and operational parameters provided by AT&T Mobility.

The compliance framework is derived from the Federal Communications Commission (FCC) Rules and Regulations for preventing human exposure in excess of the applicable Maximum Permissible Exposure ("MPE") limits. At any location at this site, the power density resulting from each transmitter may be expressed as a percentage of the frequency-specific limits and added to determine if 100% of the exposure limit has been exceeded. The FCC Rules define two tiers of permissible exposure differentiated by the situation in which the exposure takes place and/or the status of the individuals who are subject to exposure. General Population / Uncontrolled exposure limits apply to those situations in which persons may not be aware of the presence of electromagnetic energy, where exposure is not employment-related, or where persons cannot exercise control over their exposure. Occupational / Controlled exposure limits apply to situations in which persons are exposed as a consequence of their employment, have been made fully aware of the potential for exposure, and can exercise control over their exposure.

Frequency (MHz)	Limits for General Population/ Uncontrolled Exposure		Limits for Occupational/ Controlled Exposure	
	Power Density (mW/cm ²)	Averaging Time (minutes)	Power Density (mW/cm ²)	Averaging Time (minutes)
30-300	0.2	30	1	6
300-1500	f/1500	30	f/300	6
1500-100,000	1.0	30	5.0	6

f=Frequency (MHz)

In situations where the predicted MPE exceeds the General Population threshold in an accessible area as a result of emissions from multiple transmitters, FCC licensees that contribute greater than 5% of the aggregate MPE share responsibility for mitigation.

Based on the computational guidelines set forth in FCC OET Bulletin 65, Waterford Consultants, LLC has developed software to predict the overall Maximum Permissible Exposure possible at any particular location given the spatial orientation and operating parameters of multiple RF sources. These theoretical results represent worst-case predictions as emitters are assumed to be operating at 100% duty cycle.

Exhibit I

Site 3 Pleasant Valley

For any area in excess of 100% General Population MPE, access controls with appropriate RF alerting signage must be put in place and maintained to restrict access to authorized personnel. Signage must be posted to be visible upon approach from any direction to provide notification of potential conditions within these areas. Subject to other site security requirements, occupational personnel should be trained in RF safety and equipped with personal protective equipment (e.g. RF personal monitor) designed for safe work in the vicinity of RF emitters. Controls such as physical barriers to entry imposed by locked doors, hatches and ladders or other access control mechanisms may be supplemented by alarms that alert the individual and notify site management of a breach in access control. Waterford Consultants, LLC recommends that any work activity in these designated areas or in front of any transmitting antennas be coordinated with all wireless tenants.

Analysis

AT&T Mobility proposes the following installation at this location:

- Install twelve (12) new panel antennas, four (4) per alpha, beta, gamma sector
- Install twenty-one (21) new RRUS remote radio heads

The antennas will be mounted on a 160-foot Monopine with centerlines at 150 and 140 feet above ground level. The antennas will be oriented toward 30, 150 and 270 degrees. The Effective Radiated Power (ERP) in any direction from all AT&T Mobility operations will not exceed 25,997 Watts. Other appurtenances such as RRUs and hybrid cable are not sources of RF emissions. From this site, AT&T Mobility will enhance voice and data services to surrounding areas in licensed 700, 850, 1900, 2100 and 2300 MHz bands. No other antennas are known to be operating in the vicinity of this site.

Power density decreases significantly with distance from any antenna. The panel-type antennas to be employed at this site are highly directional by design and the orientation in azimuth and mounting elevation, as documented, serve to reduce the potential to exceed MPE limits at any location other than directly in front of the antennas. For accessible areas at ground level, the maximum predicted power density level resulting from all AT&T Mobility operations is 0.4700% of the FCC General Population limits (0.0940% of the FCC Occupational limits). Incident at adjacent buildings depicted in Figure 1, the maximum predicted power density level resulting from all AT&T Mobility operations is 0.6665% of the FCC General Population limits (0.1333% of the FCC Occupational limits). The proposed operation will not expose members of the General Public to hazardous levels of RF energy and will not contribute to existing cumulative MPE levels on walkable surfaces at ground or at adjacent buildings by 5% of the General Population limits.

Waterford Consultants, LLC recommends posting contact information signage at the gate that informs personnel entering the site of basic precautions to be followed when working around antennas. RF alerting signage (Caution) should be posted at the base of the proposed Monopine to inform authorized climbers of potential conditions near the antennas. These recommendations are depicted in Figure 2.

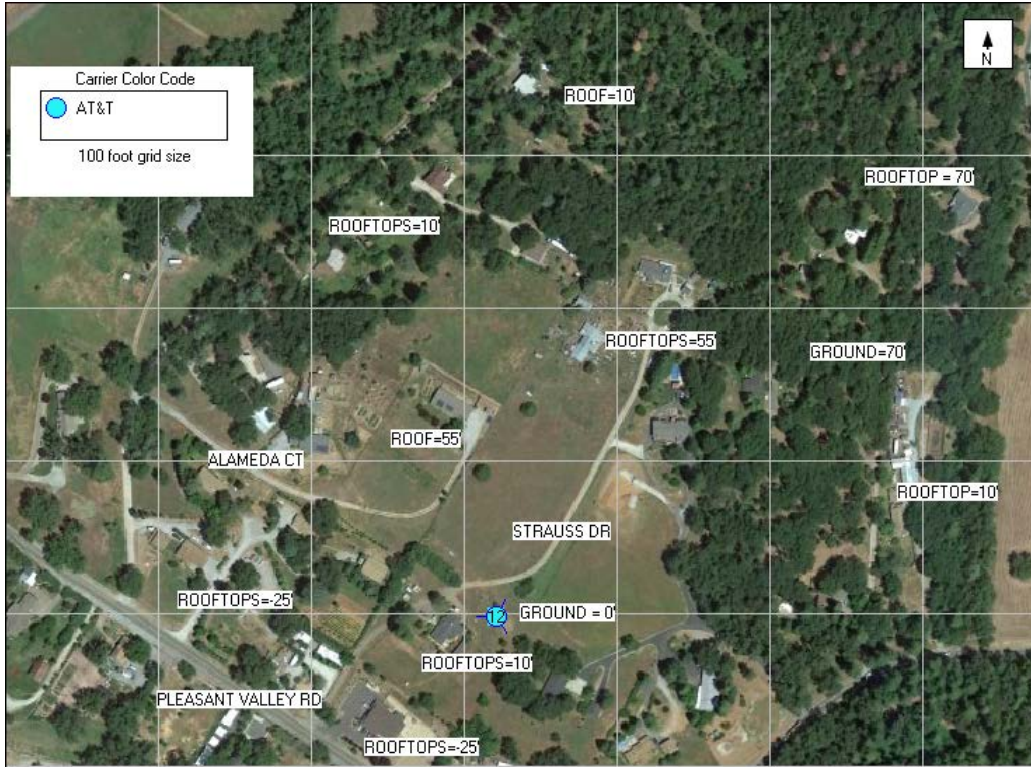

Figure 1: Antenna Locations

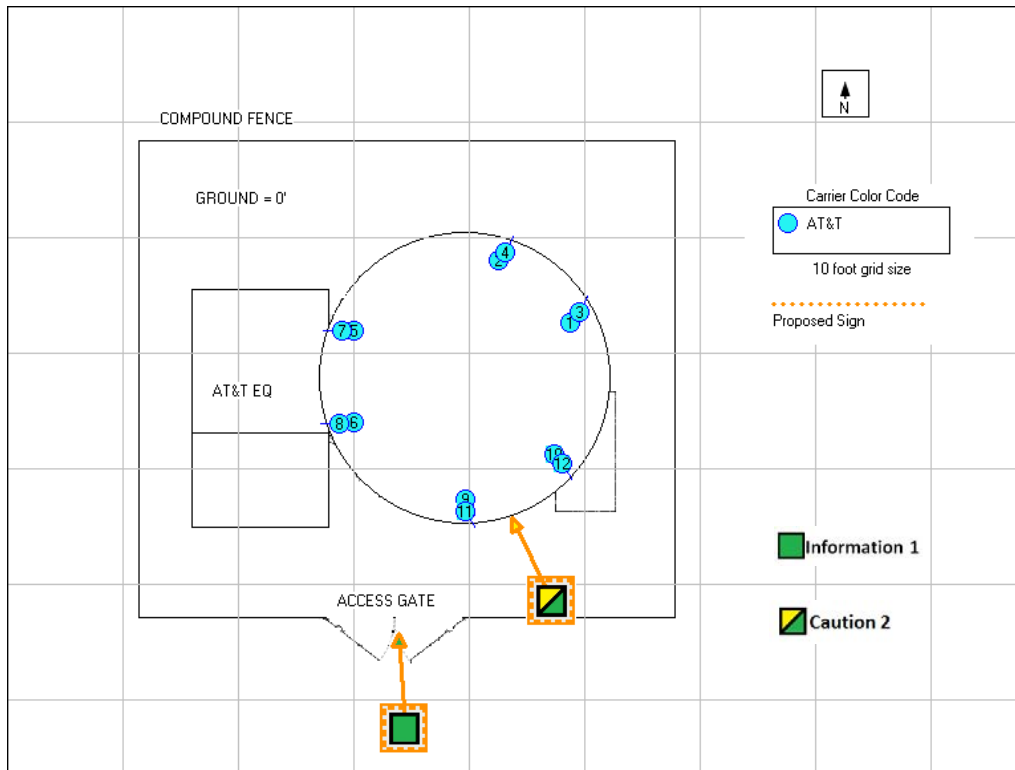

Figure 2: Mitigation Recommendations

Compliance Statement

Based on information provided by AT&T Mobility and predictive modeling, the installation proposed by AT&T Mobility at 4559 Strauss Drive, Placerville, CA will be compliant with Radiofrequency Radiation Exposure Limits of 47 C.F.R. § 1.1307(b)(3) and 1.1310. RF alerting signage and restricting access to the Monopine to authorized climbers that have completed RF safety training is required for Occupational environment compliance.

Certification

I, David H. Kiser, am the reviewer and approver of this report and am fully aware of and familiar with the Rules and Regulations of both the Federal Communications Commissions (FCC) and the Occupational Safety and Health Administration (OSHA) with regard to Human Exposure to Radio Frequency Radiation, specifically in accordance with FCC's OET Bulletin 65. I have reviewed this Radio Frequency Exposure Assessment report and believe it to be both true and accurate to the best of my knowledge.





on Behalf of



Project Background and objectives:

AT&T is participating in a Federal Government funded project called Connect America Fund (CAF) – which is to provide underserved areas throughout the United States in general and throughout El Dorado County in particular with hi-speed broadband internet. The build-up of hi-speed broadband internet throughout rural/underserved areas will not only drive economic growth in rural America, but will expand the online marketplace nationwide, creating jobs, educational and businesses opportunities across the country. The CAF project is required to provide broadband internet services capable of 10 Mbps download and 1 Mbps upload speeds.

AT&T has the necessary technology that allows them to build out their territory in El Dorado County with the much demanded hi-speed broadband internet to help improve the county's rural infrastructure. AT&T's basis for transmitting and receiving hi-speed broadband internet to residences is executed by providing one site with either a microwave fiber hop or a direct fiber line to the site and transferring the high speeds of fiber to each Living Unit (LU) via wireless signals. Each LU being provided with the service will have a small square antenna located in a vantage point on the property where it has a direct line of site to the tower. The square antenna will send and receive wireless broadband internet providing the LU with a minimum of 10/1 Mbps download and upload speeds, respectively.

AT&T's secondary objective is to provide and enhance AT&T's Wireless Telecommunications services (cellular services) to underserved areas. Cellular services go hand in hand with building the internet infrastructure throughout these underserved areas. People today rely on their mobile devices not only for educational and business purposes, but also for emergency services. Increasing AT&T's cellular coverage and capacity throughout El Dorado County's rural areas while providing wireless broadband internet will greatly assist with enhancing the county's economic growth and the area's infrastructure.

Given the need for direct line of site to residences, a taller than typical tower will be necessary in order to provide wireless broadband internet services to as many homes in the targeted areas as possible. During the tower design phase, the Radio Frequency (RF) engineer study many variables including surrounding tree heights, tree densities, population densities, and surrounding hill tops, in order to properly design a sufficient tower height with the goal of achieving the FCC's track census block mandates of reaching specific LU coverage objectives per area. Living Unit (LU) coverage objectives are provided by the RF engineer using density maps and are based on the area's approximate population. AT&T's goal is not only to reach the coverage objective, but to outperform the coverage objective to ensure that the maximum amount of homes are being provided this service while taking into consideration a small margin of error during the simulation process.

Exhibit J
Site 3 Pleasant Valley

Search Ring's Description and Objectives:



AT&T Mobility is proposing to build and maintain an unmanned wireless telecommunication facility consisting of a 40' x 45', 1,800 square foot enclosed compound (lease area). The compound will include a 160 foot Stealth Monopine tower, one equipment shelter, one 35kw standby propane generator, and one 500 gallon propane tank. This facility will be located at 4559 Strauss Drive, Placerville, within El Dorado County's jurisdiction in a 2 acre R2A zone. The site is approximately 750 feet north-west of Clear Creek and the area consists of large oak trees, "evergreen" trees, and rolling hills with rocky terrain.

AT&T's objective for the Pleasant Valley site is to provide wireless hi-speed broadband internet and cellular services to the nearby residences. This site is to provide hi-speed internet and enhanced cellular coverage & capacity to the surrounding communities. The site location's elevation is approximately 2,538 feet while the surrounding community's elevation averages around 2,450 feet, giving the homes within the surrounding communities great potential for line of site to the tower. After running a coverage simulation at the site location, AT&T is anticipating meeting their FCC objective for this search ring.

Potential Co-locations:

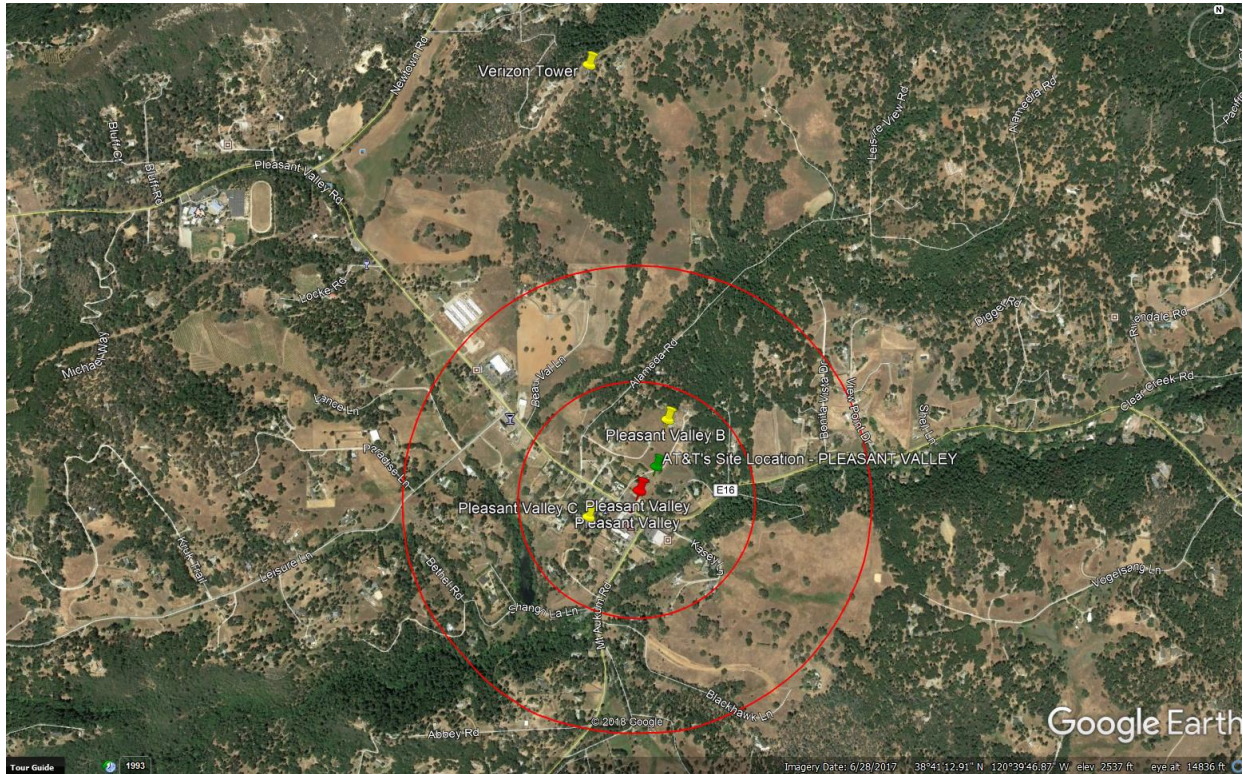

There are no potential Co-location opportunities in the near vicinity of the provided Search Ring.

There is one existing Tower owned by Verizon Wireless that is 0.85 miles north of the proposed AT&T Pleasant Valley tower. The Verizon tower provides wireless mobility services to the surrounding communities, however, the tower is insufficient for AT&T's CAF II internet project given the lengthy distance from the existing tower to AT&T's targeted area. The existing Verizon tower is designed to cover the surrounding area with wireless mobility services and was not designed for line of site for wireless internet services to each community. Even though the Verizon tower is too far for the Pleasant Valley's targeted area, AT&T still ran a coverage simulation which resulted in a 35% loss in coverage to the Pleasant Valley's targeted area. Additionally, the Verizon tower does not fill AT&T's significant gap in LTE coverage in the Pleasant Valley area.

on Behalf of

Alternative Site Analysis pursuant to 17.14.210 (B) (1):

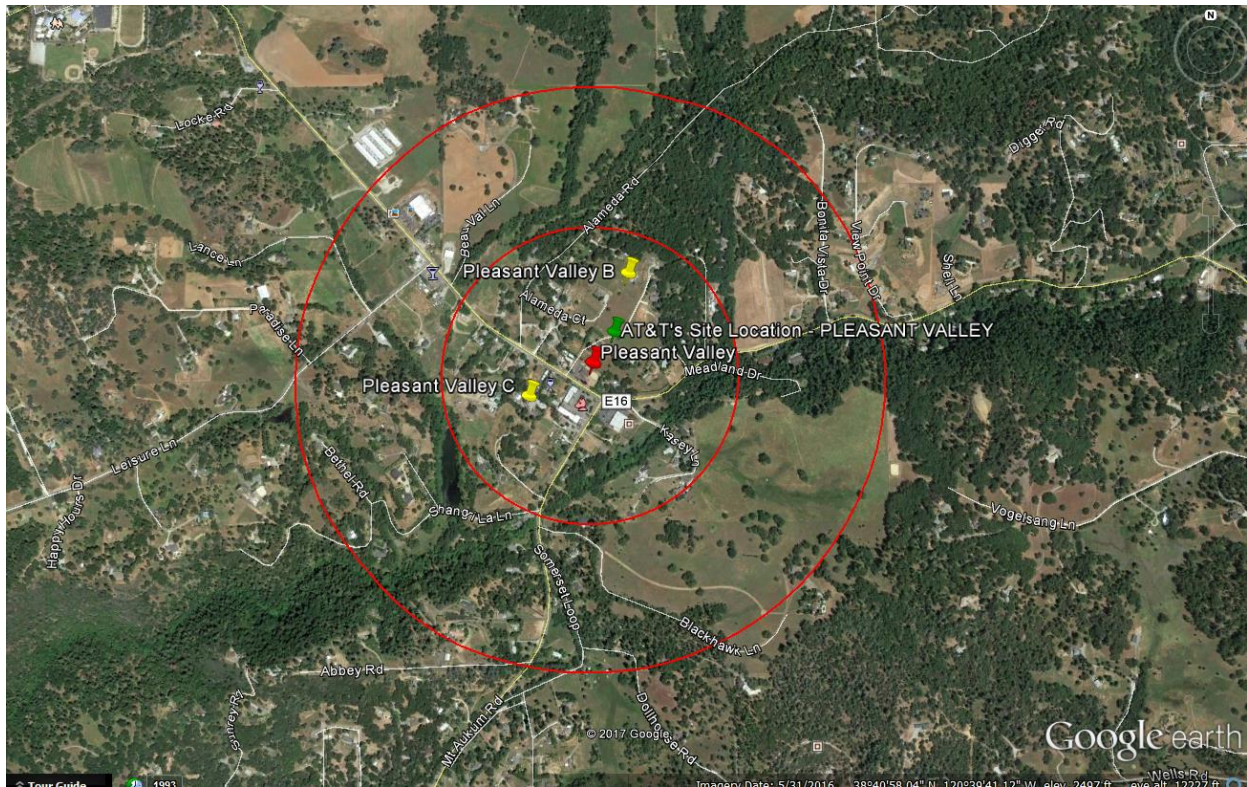

Above is a map showing the Search Ring (center is the red pin), Proposed Site (green pin) and the two alternative sites (yellow pins) that were considered for placement of the telecommunications facility. Each Alternative Site is discussed below:



on Behalf of



Pleasant Valley Alternative Candidate B:

4500 Strauss Drive, Placerville, CA 95667

Latitude/Longitude: 38.685616, -120.661565

Proposal – New Tower



Considerations:

Candidate B is located approximately 875 feet north-east of the center of AT&T's search ring. The proposed tower would be located on a 6.7 acre, R2A zoned property owned by Miklos Nemeth. The property is located on the north side of Pleasant Valley Road and the site was proposed in the center of the property. Candidate B was chosen as AT&T's primary candidate as the RF Engineer's simulation yielded 3% more LU's than the subject site located at 4559 Strauss Drive. Since the simulation yielded only 3% more LUs than the subject site location and was much more intrusive than the subject parcel, AT&T agreed to move the primary candidate to 4559 Strauss Drive. The nearest homes to the site location on 4500 Strauss Drive are approximately 180 feet and 240 feet, both in clear site to the tower. No oak woodlands were expected to be lost for this site location. The surrounding Land Use is MDR and Commercial.

Pleasant Valley Alternative Candidate C:

4546 Pleasant Valley Road, Placerville, CA 95667

Latitude/Longitude: 38.682625, -120.664595

Proposal – New Tower



Considerations:

Candidate C is located approximately 640 feet south-west of the center of AT&T's search ring. The proposed tower would be located on a 1.07 acre, R2A zoned property owned by Dennis and Laurel Nystrom. The property is located on the south side of Pleasant Valley Road and the site was proposed on the south-west side of the property. Candidate C was chosen as AT&T's third preferred candidate as the RF Engineer's simulation yielded 10% fewer LU's than the subject site located at 4559 Strauss Drive. In addition to covering fewer LU's than the Primary, Candidate C would be more intrusive being only 100 feet from the nearest residence and less than 250 feet from multiple other residences. No oak woodlands were presumed to be removed. The surrounding Land Use is MDR and Commercial.



on Behalf of

Additional alternative sites considered and letters of interest sent out but received no response by landlords included the following parcels:

4530 Pleasant Valley Road, Placerville, CA 95667 – APN: 078-150-30; Owner: Robert Findelton

4300 Leisure Ln, Placerville, CA 95667 – APN: 078-150-17; Owner: Sickinger

Additional alternative site considered but no letter of interest sent out:

4429 Pleasant Valley Road, Placerville, CA 95667 – APN: 078-270-25; Owner: El Dorado Co. Fire District

- Site Location yielded 25% fewer LUs
- Site is intrusive to nearby residences

Property information pursuant to 17.14.210 (J) (1 and 2):

Ref ID: Pleasant Valley

Property Detail Report

For Property Located At :
4546 PLEASANT VALLEY RD, PLACERVILLE, CA 95667-9208



Owner Information			
Owner Name:	NYSTROM DENNIS A & LAUREL A		
Mailing Address:	5570 OAK LEAF CIR, PLACERVILLE CA 95667-9510 H006		
Vesting Codes:	/ A / TR		
Location Information			
Legal Description:	PM 28/19/A	APN:	078-170-23-100
County:	EL DORADO, CA	Alternate APN:	078-170-23-100
Census Tract / Block:	314.04 / 2	Subdivision:	
Township-Range-Sect:		Map Reference:	35-C3 /
Legal Book/Page:		Tract #:	
Legal Lot:		School District:	EL DORADO UN
Legal Block:		School District Name:	
Market Area:	35 C3	Munic/Township:	
Neighbor Code:			
Owner Transfer Information			
Recording/Sale Date:	08/22/2000 /	Deed Type:	DEED (REG)
Sale Price:		1st Mtg Document #:	
Document #:	41740		
Last Market Sale Information			
Recording/Sale Date:	10/15/1991 / 10/1991	1st Mtg Amount/Type:	/
Sale Price:	\$47,000	1st Mtg Int. Rate/Type:	/
Sale Type:	FULL	1st Mtg Document #:	
Document #:	3646-67	2nd Mtg Amount/Type:	/
Deed Type:	GRANT DEED	2nd Mtg Int. Rate/Type:	/
Transfer Document #:		Price Per SqFt:	\$39.97
New Construction:		Multi/Split Sale:	
Title Company:	FOUNDERS TITLE CO.		
Lender:			
Seller Name:	HALL GENE F		
Prior Sale Information			
Prior Rec/Sale Date:	12/01/1980 /	Prior Lender:	
Prior Sale Price:	\$55,000	Prior 1st Mtg Amt/Type:	/
Prior Doc Number:	1933-127	Prior 1st Mtg Rate/Type:	/
Prior Deed Type:	DEED (REG)		
Property Characteristics			
Gross Area:		Parking Type:	Construction:
Living Area:	1,176	Garage Area:	Heat Type:
Tot Adj Area:		Garage Capacity:	Exterior wall:
Above Grade:		Parking Spaces:	Porch Type:
Total Rooms:	4	Basement Area:	Patio Type:
Bedrooms:	3	Finish Bsmnt Area:	Pool:
Bath(F/H):	2 /	Basement Type:	Air Cond:
Year Built / Eff:	2004 / 2005	Roof Type:	Style:
Fireplace:	/	Foundation:	Quality:
# of Stories:	1.00	Roof Material:	Condition:
Other Improvements:			AVERAGE
			AVERAGE
Site Information			
RESIDENTIAL IMPRVD TO			
Zoning:	R2A	Acres:	1.07
County Use:		County Use:	2.5 AC (11)
Lot Area:	46,609	Lot Width/Depth:	x
State Use:		State Use:	
Land Use:	SFR	Res/Comm Units:	30 /
Water Type:		Water Type:	
Site Influence:		Sewer Type:	
Tax Information			
Total Value:	\$324,000	Assessed Year:	2015
Property Tax:		Property Tax:	\$3,656.10
Land Value:	\$65,000	Improved %:	80%
Tax Area:		Tax Area:	085016
Improvement Value:	\$259,000	Tax Year:	2015
Tax Exemption:		Tax Exemption:	
Total Taxable Value:	\$324,000		

Actual View of the Proposed Location:

The proposed lease area is located on the north end of the property. The site will not interfere with the existing Land Use of the property, MDR. Access will be directly off of Pleasant Valley Road and Strauss Drive. The site is elevated above the surrounding area and has great potential for line of site to the nearby community. The nearest homes to the site location is approximately 220-230 feet and located approximately 300 feet to the north of the Pet Clinic. No oak trees will be scientifically impacted or removed. A grove of trees to the east and west stealth the facility from the nearby homes in those directions. The facility will be visible from the residences to the north, however, those residences are over 400 feet from the facility.



Planning Services

Home > Government > Planning

PARCEL DATA INFORMATION

7/28/2017

[Enter Another Parcel](#)

Assessor's Parcel Number: 078-180-38

PROPERTY INFORMATION:

STATUS	JURISDICTION	TAX RATE	MAP	ACREAGE
ON ASSESSMENT ROLL AND TAXED	COUNTY OF EL DORADO	85 - 16	PM 32/33/2	2.08

2015 GENERAL PLAN LAND USE INFORMATION:

LAND USE DES.	AG DIST.	ECOLOGICAL PRESERVES	IMPORTANT BIOLOGICAL CORRIDOR	MINERAL RESOURCES	PLATTED LANDS	COMMUNITY REGIONS	RURAL CENTERS	SPECIFIC PLANS	ADOPTED PLAN NAME
MDR							PV		

2015 ZONING INFORMATION:

ZONING DESIGNATION	DESIGN CONTROL	PLANNED DEVELOPMENT	OTHER OVERLAYS
R2A			

2004 GENERAL PLAN LAND USE INFORMATION:

LAND USE DES.	AG DIST.	ECOLOGICAL PRESERVES	IMPORTANT BIOLOGICAL CORRIDOR	MINERAL RESOURCES	PLATTED LANDS	COMMUNITY REGIONS	RURAL CENTERS	SPECIFIC PLANS	ADOPTED PLAN NAME
MDR							PV		

2004 ZONING INFORMATION:

ZONING DESIGNATION	DESIGN CONTROL	PLANNED DEVELOPMENT	OTHER OVERLAYS
R2A			

DISTRICTS:

FIRE	CSD	SCHOOL	WATER
EL DORADO COUNTY FPD		GOLD OAK UNION	EL DORADO IRRIGATION DIST

FLOOD ZONE INFORMATION (See Note below):

FIRM PANEL NUMBER & REVISION	PANEL REVISION DATE	FLOOD ZONE	FLOOD ZONE BUFFER	FLOODWAY
06017C0800E	09/26/2008	X		

MISCELLANEOUS DATA:

SUPERVISORIAL DISTRICT	AG PRESERVE	RARE PLANT MITIGATION AREA	MISSOURI FLAT MC&FP
2	SHIVA FRENTZEN	Mitigation Area 2	No

REMARKS:

No Eligibility Review Required

NOTE: The flood zone information presented here is based solely on data derived from the FEMA Flood Information Rate Maps, and does not include data from any other flood studies.

Assessor's Parcel Map

POR. SECS. 28 & 33, T.10N., R.12E., M.D.M.

Tax Area Code 78:18

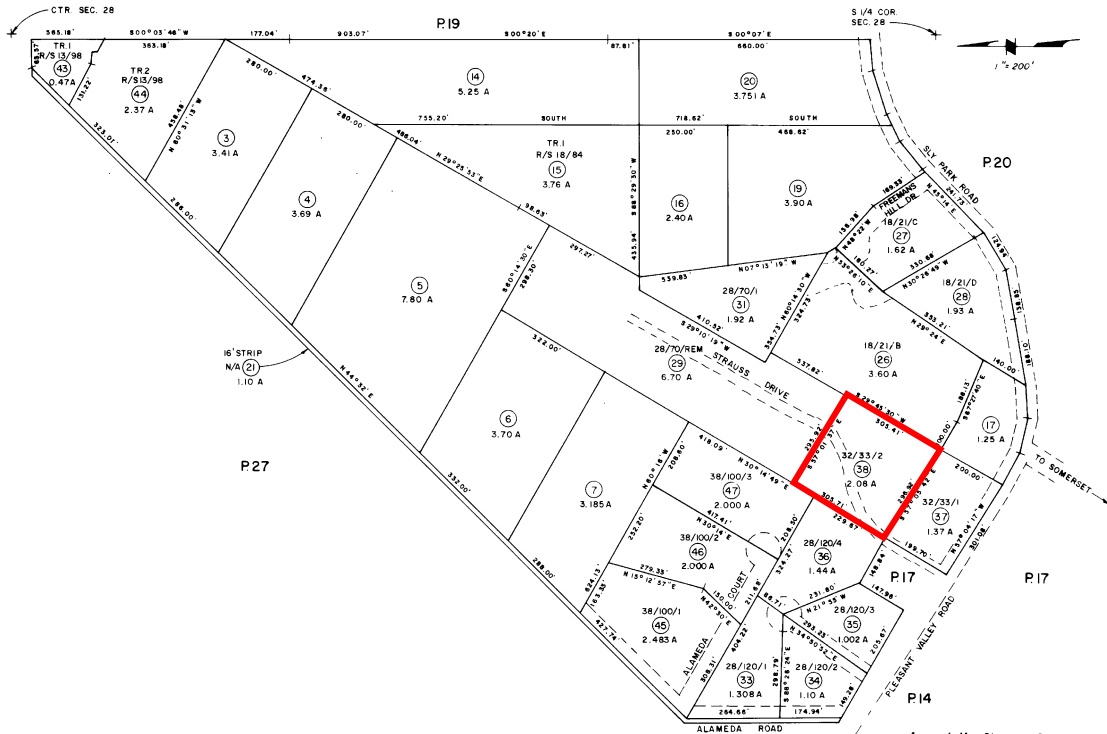

THIS MAP IS NOT A SURVEY. It is prepared by the El Dorado Co. Assessor's office for assessment purposes only.

NOTE - Assessor's Block Numbers Shown in Ellipses
Assessor's Parcel Numbers Shown in Circles

Assessor's Map Bk. 78 - Pg. 18
County of El Dorado, California

Zoning Map

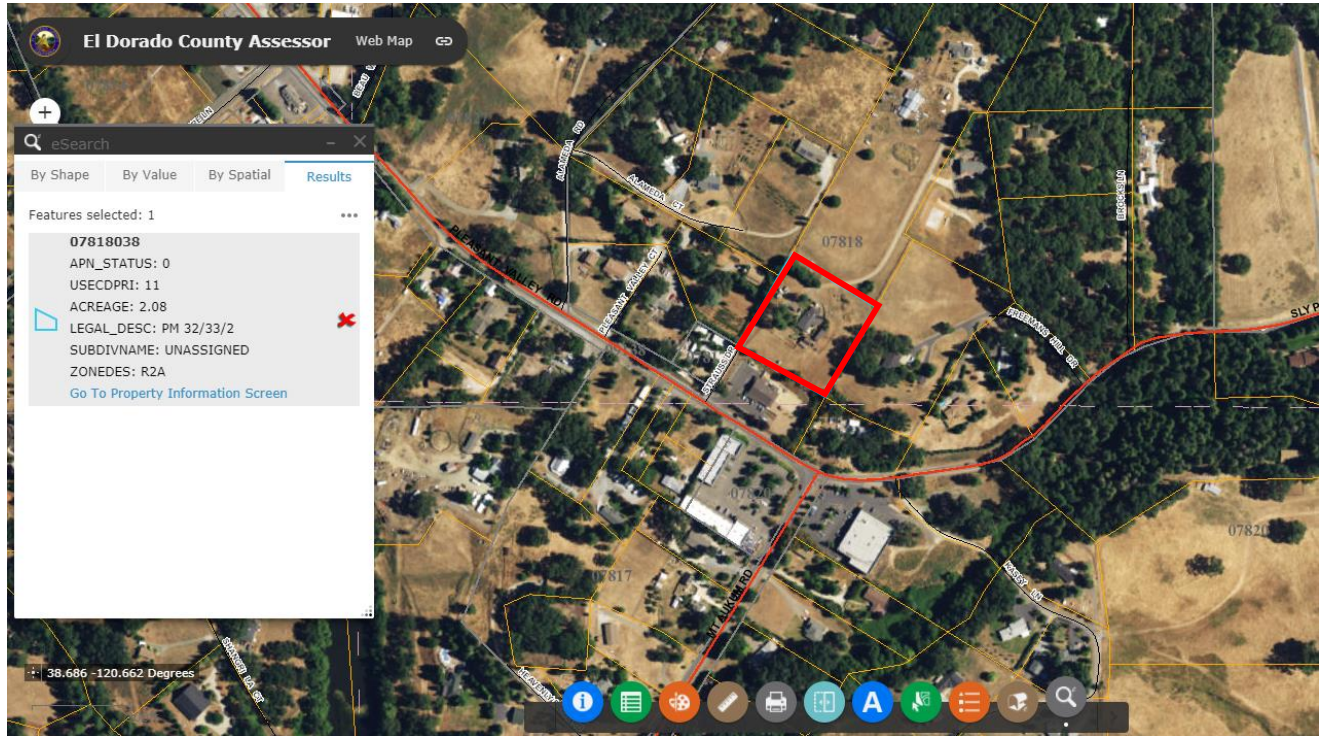

The screenshot displays the El Dorado County Assessor's Web Map interface. A satellite map shows a residential area with property boundaries outlined in yellow. A specific property is highlighted with a red border. A popup window on the left provides details for the selected property:

- 07818038
- APN_STATUS: 0
- USECDPRI: 11
- ACREAGE: 2.08
- LEGAL_DESC: PM 32/33/2
- SUBDIVNAME: UNASSIGNED
- ZONEDES: R2A

Below the popup, there is a link: [Go To Property Information Screen](#). The map interface includes a search bar at the top left, a toolbar at the bottom with various icons, and a coordinate display at the bottom left showing 38.686 -120.662 Degrees.

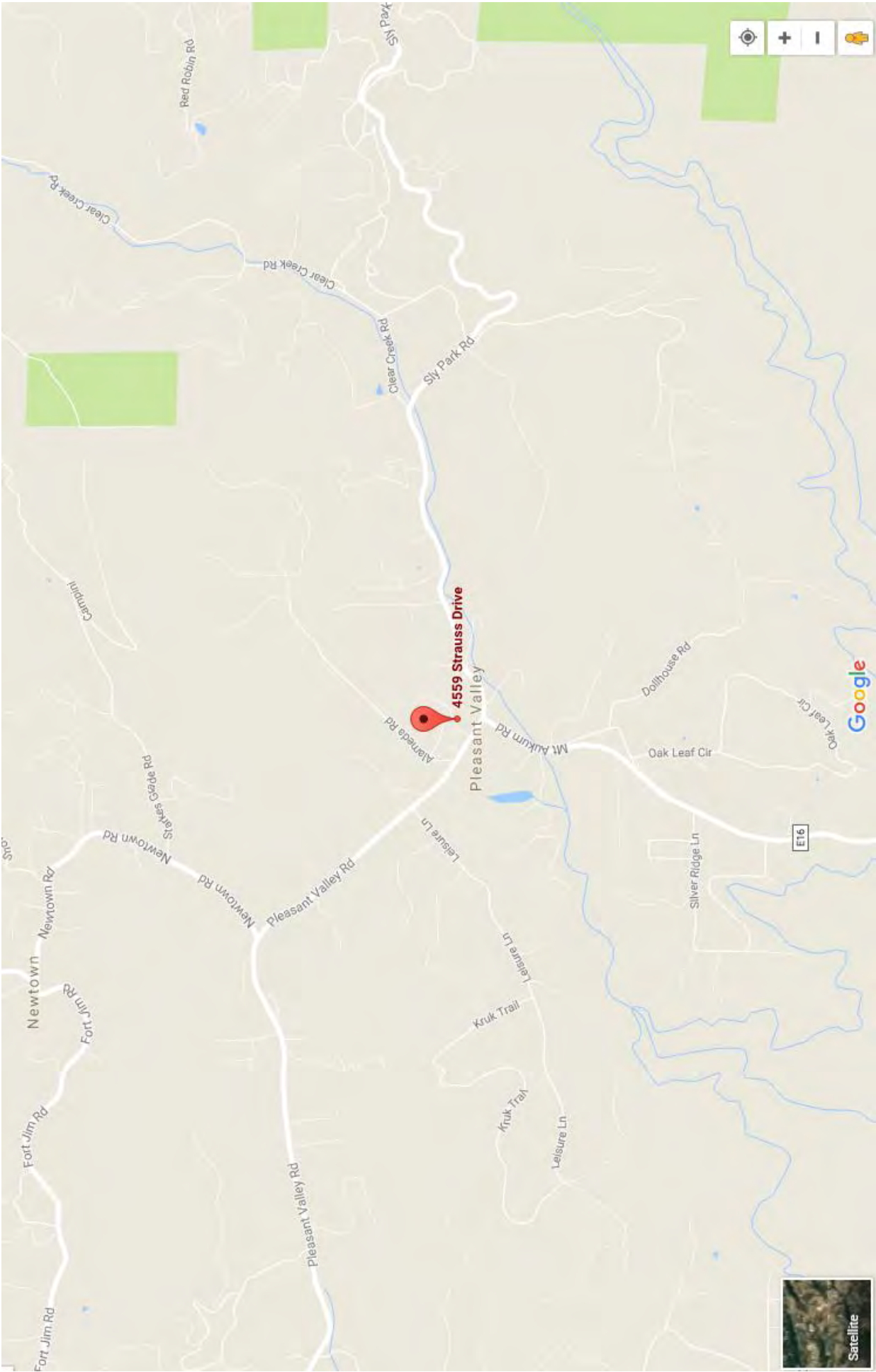

4559 Strauss Drive

Pleasant Valley

Google

Satellite

ET16

Red Robin Rd

Sly Park

Clear Creek Rd

Clear Creek Rd

Sly Park Rd

Campbell

Stakes Green Rd

Newtown Rd

Newtown Rd

Fort Jim Rd

Fort Jim Rd

Fort Jim Rd

Pleasant Valley Rd

Pleasant Valley Rd

Alameda Rd

Leisure Ln

Kruk Trail

Kruk Trail

Leisure Ln

Pleasant Valley Rd

Mt Aukum Rd

Dollhouse Rd

Oak Leaf Cir

Silver Ridge Ln

Oak Leaf Cir

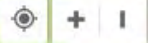

on Behalf of

Overhead View of Lease Area and Distances to nearby residences:



Emergency 35kw Propane Generator and 4 Ton HVAC Noise Analysis:

- **Equation and Calculation Method:**

The sound analysis methods and results are hypothetical only, using Sound Level and Distance calculations. These calculations do not take outside sounds, compound walls, trees, hills, buildings, and other sound dampening variables into consideration, but, only raw sound levels after specific traveled distances which results in the worst case scenario for the sounds of the onsite backup generator and HVAC systems.

Formulas to calculate the sound level L in dB (sound pressure level or sound intensity level) in dependence of the distance r .

Sound level L and Distance r

$$L_2 = L_1 - \left| 20 \cdot \log \left(\frac{r_1}{r_2} \right) \right| \quad L_2 = L_1 - \left| 10 \cdot \log \left(\frac{r_1}{r_2} \right)^2 \right|$$

$$r_2 = r_1 \cdot 10^{\left(\frac{|L_1 - L_2|}{20} \right)} \quad r_1 = \frac{r_2}{10^{\left(\frac{|L_1 - L_2|}{20} \right)}}$$

Sound pressure level (dB) = Sound intensity level (dB)

$L_2 = L_1 - \left 20 \cdot \log \left(\frac{r_1}{r_2} \right) \right $	$L_2 = L_1 - 10 \cdot \lg \left(\frac{r_1}{r_2} \right)^2$
---	---

Sound Specifications:

- Emergency Generator Model: SG035 Generac
 - Average decibel (dBA) level at 23 feet = 64.9 dBA
- HVAC Model: ASDCA48
 - Average decibel (dBA) level at 50 feet = 57 dBA

Sound Specifications while taking the Proposed Sound Blanket into consideration:

- Emergency Generator Model: SG035 Generac
 - Average decibel (dBA) level at 23 feet = 58.11 dBA
- HVAC Model: ASDCA48
 - Average decibel (dBA) level at 50 feet = 46.36 dB

Findings:

1. Distance to the Property Line of APN 078-180-29 = 30'
 - a. Generator Decibel level at 30' = 55.8 dBA
 - b. HVAC Decibel level at 30' = 50 dBA
2. Distance to the Property Line of APN 078-180-26 = 59'+/-
 - a. Generator Decibel level at 59' = 49.93 dBA
 - b. HVAC Decibel level at 59' = 44.95 dBA
3. Distance to Residence of APN 078-180-26 = 220'
 - a. Generator Decibel level at 220' = 38.5 dBA
 - b. HVAC Decibel level at 220' = 33.49 dBA

Conclusion:

After calculating all decibel levels at each nearby property line and residence, the onsite Emergency Backup Generator and HVAC systems are within El Dorado County's noise level standards according to El Dorado County Title 130 Zoning and Noise Ordinance, Chapter 130.37 – Noise Standards.

Table 1 – Eldorado County Table 130.37.060.1
Noise Level Performance Standards for Noise Sensitive Land Uses
Affected by Non-Transportation Sources

Noise Level Descriptor	Daytime 7 a.m. – 7 p.m.		Evening 7 p.m. – 10 p.m.		Night 10 p.m. – 7 a.m.	
	Community / Rural Centers	Rural Regions	Community / Rural Centers	Rural Regions	Community / Rural Centers	Rural Regions
Hourly Leq, dBA	55	50	50	45	45	40
Maximum Level, dBA	70	60	60	55	55	50

BBC-13X Sound Curtains

Sound Seal's **BBC-13X** offers the benefits of both a noise barrier and a sound absorber for outdoor applications. The BBC-13X consists of a one-inch thick vinyl-coated-fiberglass-cloth faced quilted fiberglass that is bonded to a one-pound per sq. ft. reinforced loaded vinyl noise barrier. **"X"** style Sound Curtain panels are constructed with grommets across the top and **bottom, and exterior grade** Velcro seals along the vertical edges. The product is also available in roll form with edges bound or unbound.

- Class A (or 1) flammability rated per ASTM E 84
- For use on Indoor or Outdoor Applications
- Available facing colors: gray, tan, black, or off-white
- Available barrier colors: gray, tan, blue or olive drab



Applications:

Even in the harshest environments, with a minimum life span of 5 years* and wind load ratings of 120 mph, this product is typically used as a **temporary noise barrier on outdoor applications such as construction site noise mitigation projects**. Also available with a two-pound psf noise barrier or a two-inch thick quilted fiberglass sound absorber for better acoustical performance.

Product Data:

Description	Vinyl coated fiberglass cloth facing on 1" quilted fiberglass 1lb-psf reinforced loaded vinyl barrier
Flammability	Flame Spread: 23.0 Smoke density: 30.0
Nominal thickness	1.0 inch
Temperature range	-20° to +180° F
Standard roll size	54" wide x 25' long
Weight	1.2 lb psf

Acoustical Performance:

Sound Transmission Loss

Product	OCTAVE BAND FREQUENCIES (Hz)						STC
	125	250	500	1000	2000	4000	
BBC-13 X	11	16	24	30	35	35	27

ASTM E-90 & E 413

Sound Absorption Data

Product	OCTAVE BAND FREQUENCIES (Hz)						NRC
	125	250	500	1000	2000	4000	
BBC-13 X	.12	.47	.85	.84	.64	.62	.70

ASTM C 423

* when properly installed.



on Behalf of



Operation Statement:

This project is an AT&T Mobility unmanned Telecommunication Wireless Facility. It will consist of the following:

NEW SITE BUILD UNMANNED TELECOMMUNICATIONS FACILITY.

1. BRING POWER / TELCO / FIBER TO SITE LOCATION
2. GRAVEL ROAD IMPROVEMENT FROM ROW
3. 40'X45' FENCED LEASE AREA
4. INSTALL AT&T APPROVED PRE-MANUFACTURED EQUIPMENT CABINET AND ASSOCIATED INTERIOR EQUIPMENT
5. ADD (1) NEW GPS UNITS
6. ADD 160'-0" MONOPINE
7. ADD (12) ANTENNAS (4) PER ALPHA, BETA, GAMMA SECTOR
8. ADD (21) RRUS
9. ADD (4) SURGE SUPPRESSORS
10. ADD (2) FUTURE 4' MICROWAVE DISHES
11. ADD 6'-0" HIGH CHAIN LINK FENCE W/ VYNAL SLATS
12. ADD 35KW LP PROPANE GENERATOR
13. ADD 500 GAL LP PROPANE STORAGE TANK

The facility will operate 24 hours a day 7 days a week. Maintenance workers will visit the site approximately once a month. A 15-foot-wide access route will be created directly from Strauss Drive. There will be minimal noise from the standby generator, turning on once a week for 15 minutes for maintenance purposes during regular business hours and during emergency power outages. The Facility is approximately 220 feet northwest of a residence, and approximately 230 feet east of another nearby residence. The surrounding area is covered with oak tree and pine tree backdrops, therefore, a Monopine Tower is proposed to blend in with the surrounding area. The tower will be built to provide co-location opportunities.

Fire Suppression System:

A 15 foot wide access route will be created directly from Strauss Drive with a fire hammerhead turnaround at the facility. A Fire Department Knox Box will be located at the Facility's access gate. Additionally, a 2A:20BC Rated Fire Extinguisher in a weather resistant cabinet will be mounted on the exterior wall of the proposed shelter.



on Behalf of



Conclusion:

Candidate A, 4995 Strauss Drive, meets the FCC's mandated objectives for the targeted area of Pleasant Valley and is the best choice for the surrounding area. The chosen location will meet the FCC's mandated coverage objectives with providing hi-speed broadband internet to the homes in the Pleasant Valley Targeted area of El Dorado County. The Stealth Monopine Tower design has been chosen to blend into the existing surrounding environment as the least intrusive means while filling AT&T's significant gap in coverage. No Oak Woodlands will be removed during the project. No special species or protected animals will be impacted per the biological resource assessment prepared by Sycamore Environmental Consultants, Inc. The site exceeds the FCC's coverage requirements (LUs) for the targeted area. Additionally, this site covers 10%-25% more LUs than the backup candidates and 35% more than the existing Verizon Tower that is 0.85 miles to the north. The Proposed Wireless Facility is an allowed use on the property subject to the approval of a Conditional Use Permit.

**LETTER OF AUTHORIZATION
TO FILE PERMIT APPLICATIONS**

Re: El Dorado County APN # 078-180-38-100

To Whom It May Concern:

The undersigned, Landlord, are the owners of the property located at 4559 Strauss Dr, Placerville, CA 95667, County Assessor's Parcel No. #078-180-38-100, that is the subject of a CUP application for a new AT&T Mobility Telecommunications Facility. The undersigned, Landlord, authorizes AT&T Mobility, C/O Epic Wirelss Group, and hereby authorizes Epic Wireless Group, its agent, to act as applicant to obtain any and all permits required for the approval and construction of this antenna/communication facility.

Landlord/Lessor: Vincent & Jo Anne Glowczwskie

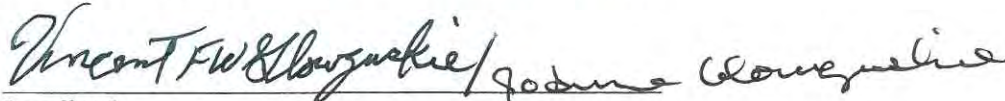
Landlord

7-7-2017
Date



Radio Frequency Emissions Compliance Report For AT&T Mobility

Site Name: Pleasant Valley-C	Site Structure Type: Monopine
Address: 4559 Strauss Drive Placerville, CA	Latitude: 38.68417
Report Date: July 21, 2017	Longitude: -120.661996
	Project: New Build

General Summary

AT&T Mobility has contracted Waterford Consultants, LLC to conduct a Radio Frequency Electromagnetic Compliance assessment of the proposed Pleasant Valley-C site located at 4559 Strauss Drive, Placerville, CA. This report contains information about the radio telecommunications equipment to be installed at this site and the surrounding environment with regard to RF Hazard compliance. This assessment is based on installation designs and operational parameters provided by AT&T Mobility.

The compliance framework is derived from the Federal Communications Commission (FCC) Rules and Regulations for preventing human exposure in excess of the applicable Maximum Permissible Exposure ("MPE") limits. At any location at this site, the power density resulting from each transmitter may be expressed as a percentage of the frequency-specific limits and added to determine if 100% of the exposure limit has been exceeded. The FCC Rules define two tiers of permissible exposure differentiated by the situation in which the exposure takes place and/or the status of the individuals who are subject to exposure. General Population / Uncontrolled exposure limits apply to those situations in which persons may not be aware of the presence of electromagnetic energy, where exposure is not employment-related, or where persons cannot exercise control over their exposure. Occupational / Controlled exposure limits apply to situations in which persons are exposed as a consequence of their employment, have been made fully aware of the potential for exposure, and can exercise control over their exposure.

Frequency (MHz)	Limits for General Population/ Uncontrolled Exposure		Limits for Occupational/ Controlled Exposure	
	Power Density (mW/cm ²)	Averaging Time (minutes)	Power Density (mW/cm ²)	Averaging Time (minutes)
30-300	0.2	30	1	6
300-1500	f/1500	30	f/300	6
1500-100,000	1.0	30	5.0	6

f=Frequency (MHz)

In situations where the predicted MPE exceeds the General Population threshold in an accessible area as a result of emissions from multiple transmitters, FCC licensees that contribute greater than 5% of the aggregate MPE share responsibility for mitigation.

Based on the computational guidelines set forth in FCC OET Bulletin 65, Waterford Consultants, LLC has developed software to predict the overall Maximum Permissible Exposure possible at any particular location given the spatial orientation and operating parameters of multiple RF sources. These theoretical results represent worst-case predictions as emitters are assumed to be operating at 100% duty cycle.

For any area in excess of 100% General Population MPE, access controls with appropriate RF alerting signage must be put in place and maintained to restrict access to authorized personnel. Signage must be posted to be visible upon approach from any direction to provide notification of potential conditions within these areas. Subject to other site security requirements, occupational personnel should be trained in RF safety and equipped with personal protective equipment (e.g. RF personal monitor) designed for safe work in the vicinity of RF emitters. Controls such as physical barriers to entry imposed by locked doors, hatches and ladders or other access control mechanisms may be supplemented by alarms that alert the individual and notify site management of a breach in access control. Waterford Consultants, LLC recommends that any work activity in these designated areas or in front of any transmitting antennas be coordinated with all wireless tenants.

Analysis

AT&T Mobility proposes the following installation at this location:

- Install twelve (12) new panel antennas, four (4) per alpha, beta, gamma sector
- Install twenty-one (21) new RRUS remote radio heads

The antennas will be mounted on a 160-foot Monopine with centerlines at 150 and 140 feet above ground level. The antennas will be oriented toward 30, 150 and 270 degrees. The Effective Radiated Power (ERP) in any direction from all AT&T Mobility operations will not exceed 25,997 Watts. Other appurtenances such as RRUs and hybrid cable are not sources of RF emissions. From this site, AT&T Mobility will enhance voice and data services to surrounding areas in licensed 700, 850, 1900, 2100 and 2300 MHz bands. No other antennas are known to be operating in the vicinity of this site.

Power density decreases significantly with distance from any antenna. The panel-type antennas to be employed at this site are highly directional by design and the orientation in azimuth and mounting elevation, as documented, serve to reduce the potential to exceed MPE limits at any location other than directly in front of the antennas. For accessible areas at ground level, the maximum predicted power density level resulting from all AT&T Mobility operations is 0.4700% of the FCC General Population limits (0.0940% of the FCC Occupational limits). Incident at adjacent buildings depicted in Figure 1, the maximum predicted power density level resulting from all AT&T Mobility operations is 0.6665% of the FCC General Population limits (0.1333% of the FCC Occupational limits). The proposed operation will not expose members of the General Public to hazardous levels of RF energy and will not contribute to existing cumulative MPE levels on walkable surfaces at ground or at adjacent buildings by 5% of the General Population limits.

Waterford Consultants, LLC recommends posting contact information signage at the gate that informs personnel entering the site of basic precautions to be followed when working around antennas. RF alerting signage (Caution) should be posted at the base of the proposed Monopine to inform authorized climbers of potential conditions near the antennas. These recommendations are depicted in Figure 2.

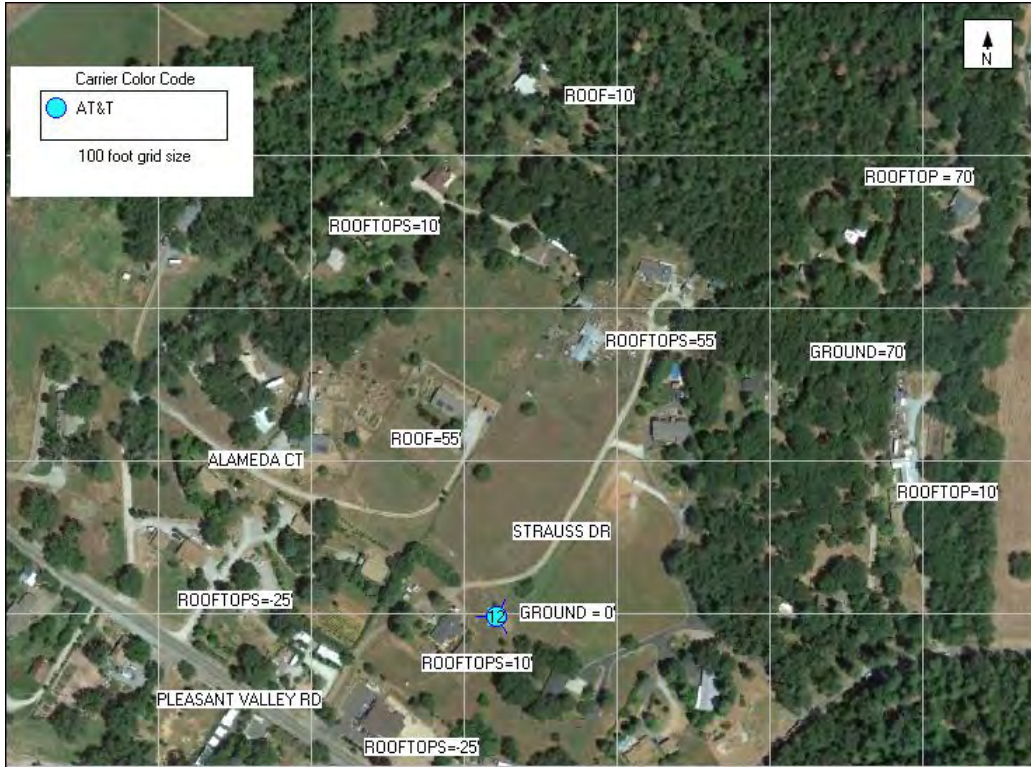

Figure 1: Antenna Locations

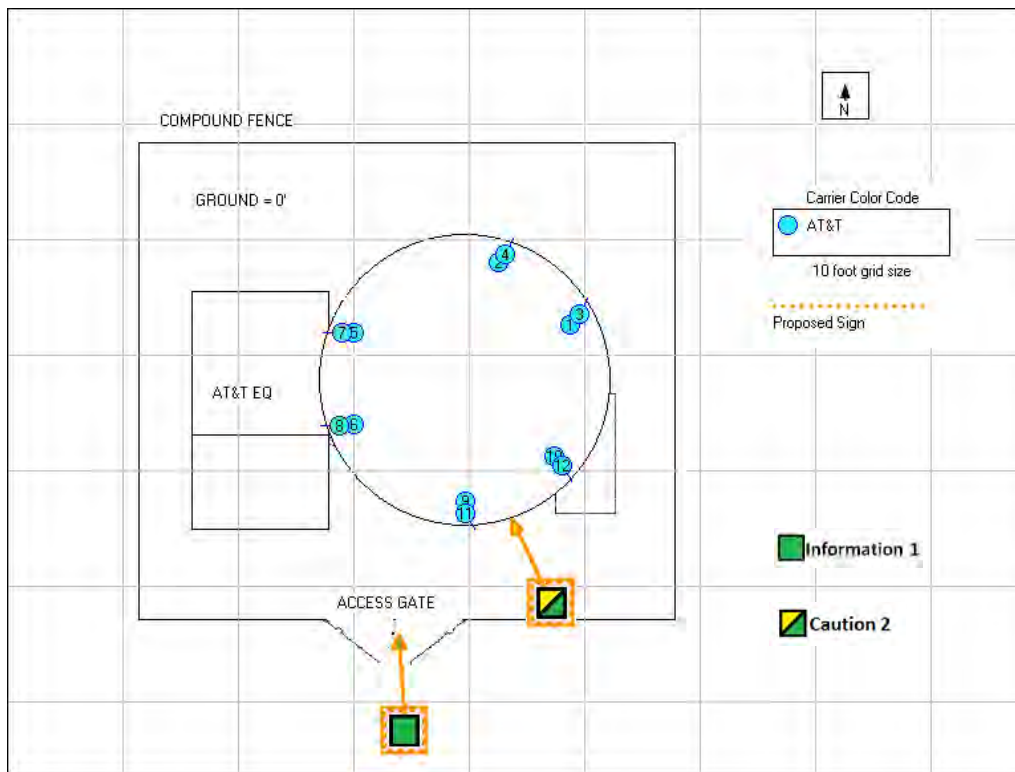

Figure 2: Mitigation Recommendations

Compliance Statement

Based on information provided by AT&T Mobility and predictive modeling, the installation proposed by AT&T Mobility at 4559 Strauss Drive, Placerville, CA will be compliant with Radiofrequency Radiation Exposure Limits of 47 C.F.R. § 1.1307(b)(3) and 1.1310. RF alerting signage and restricting access to the Monopine to authorized climbers that have completed RF safety training is required for Occupational environment compliance.

Certification

I, David H. Kiser, am the reviewer and approver of this report and am fully aware of and familiar with the Rules and Regulations of both the Federal Communications Commissions (FCC) and the Occupational Safety and Health Administration (OSHA) with regard to Human Exposure to Radio Frequency Radiation, specifically in accordance with FCC's OET Bulletin 65. I have reviewed this Radio Frequency Exposure Assessment report and believe it to be both true and accurate to the best of my knowledge.



CVL03180 Zoning Propagation Map

July 24th , 2017



Street View With Existing and Proposed Site

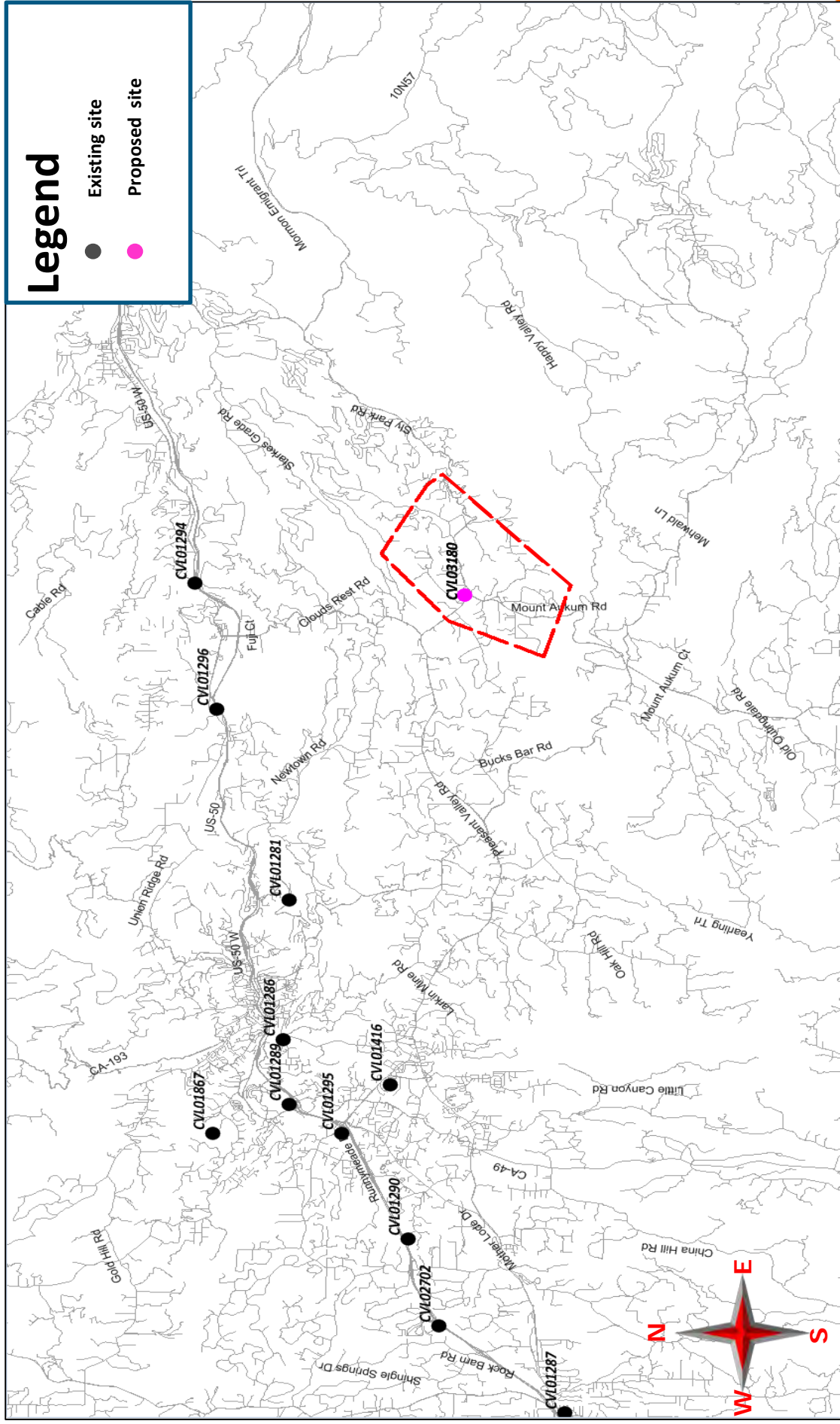

Existing LTE 700 Coverage

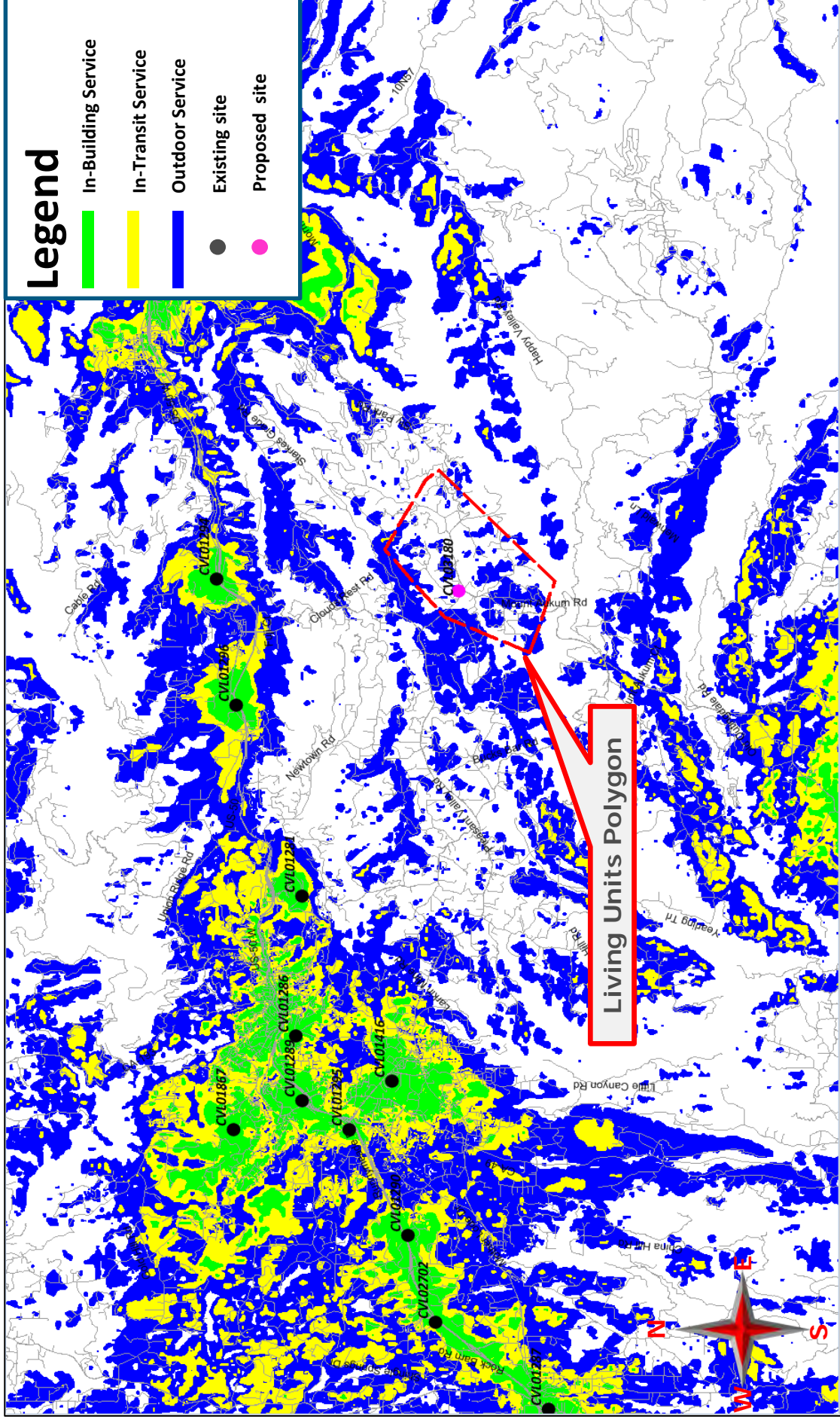

Existing LTE 700 Coverage With CVL03180 @ RC – 150ft Supports 255 LU's

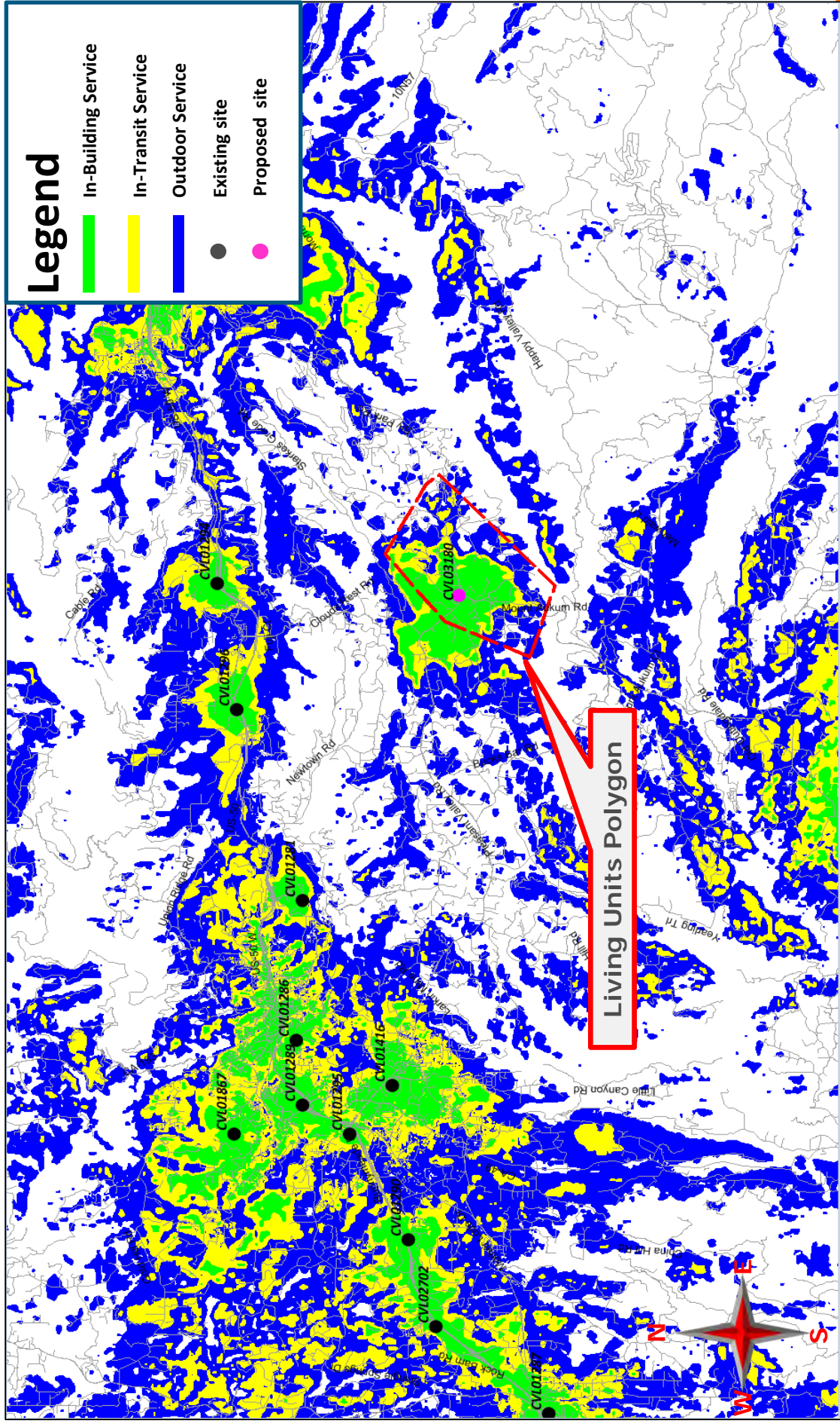



**Marvair DC Free Air HVAC Unit
with 48 VDC Evaporator Fan Motor, 100%
Free Cooling and CoolLinks™ Controller**

Models ASDCA36-42-48-60-72

PRELIMINARY

General Description

The Marvair® ComPac® II air conditioners are designed to cool telecommunications shelters where the high internal heat load requires year round cooling-even when ambient temperatures are below 60°F (15°C). To provide cooling during a wide range of ambient conditions, the ASDCA air conditioners have the necessary controls and components for year round cooling. The unit uses the non-ozone depleting R-410A refrigerant.

DC power provides emergency cooling/ventilation

Should there be loss of power to the site, the Marvair DC Free Air unit will continue to cool/ventilate the site by utilizing DC power to introduce outside air into the shelter for free cooling. The DC Free Air unit will continue to ventilate the site and extend the run time of the equipment until battery power is exhausted or, at the minimum, owner specified pull down of battery drain.



ASDCA36

The ASDCA models operate on both AC and DC power. The compressor, condenser fan motor and electric heat operate on AC power, but the evaporator motors, the 100% free cooling economizer damper and the internal control board operate on DC power – an inverter is **not** required. Since these key components are all powered by 48 VDC – the same 48 VDC power used by the shelter's radios- they are always operational.

The 48 VDC power supply connects to an internal DC breaker. From this breaker, power is supplied to the DC indoor blower and control board. A 48 VDC to 24 VDC converter powers the 100% DC free cooling damper.

Free Cooling with the Marvair 100% Full flow Economizer

When the outside air is cool and dry, the economizer damper opens and draws in filtered, outside air to cool the shelter. The Marvair 100% full flow economizer means the same CFM of outside air is brought into the shelter as the rated air flow of the unit. The innovative design of the full flow economizer assembly also allows outside air to exit the building – pressure relief- when the full flow economizer is operating. This design eliminates the need for additional, costly penetrations in the shelter.

Free cooling provides temperature control, energy savings, and increased reliability by decreasing the operating hours of the compressor and the condenser fan. To insure proper operation and optimum performance, all economizers are non-removable, factory installed and tested.

CoolLinks™ PLC controller

The Siemens PLC-based CoolLinks controller sequences the operation of the two Marvair ComPac II units to ensure the most energy-efficient conditioning of the shelter space and the most balanced use of the conditioning equipment. The CoolLinks system determines the need to cool or heat the shelter based on an indoor temperature sensor and outside temperature/humidity sensor connected directly to the controller. When cooling or heating is required, the controller selects the unit that was not running in the previous cooling/heating cycle. This lead/lag operation ensures that each unit receives equal runtime and therefore extends the operating life of the units. In the event that one of the units is unavailable, for example, scheduled maintenance, the system will automatically select the active unit. Similarly, if the internal shelter temperature continues to rise/fall, the system will run both units.

For cooling requests, the CoolLinks controller first examines the external shelter conditions to establish whether DC Free Cooling is possible. If acceptable, the 100% full flow economizer damper on the lead unit is opened to 100%. The damper then modulates its position, regulated by the controller, to cool the shelter to the target set point. During extreme cold outdoor temperatures this prevents “shocking” the equipment in the shelter.

If DC Free Cooling is active on one unit and the internal temperature continues to rise, DC Free Cooling will then be activated on the second unit. Should the temperature continue to rise, the DC Free Cooling will be disabled on both units, both economizer dampers will be closed, and mechanical cooling activated on the lead unit. The control scheme allows the CoolLinks controller to make as efficient use of the external air as possible to minimize HVAC power consumption.

The CoolLinks controller communicates with the Marvair air conditioners over Ethernet. Should communications between the controller and one of the units fail, the unit will continue to run in stand-alone mode and cool to a mixed-air set point of 55°F (12.8°C). Whenever communications are restored, the CoolLinks controller will assume control of the air conditioner. An Ethernet connection is also provided for a SNMP interface through which the Network Operations Center can receive traps (alarms), monitor/change cooling and heating set points, and monitor HVAC unit and system operational parameters.

Air Conditioner Alarms and Lockouts

Each air conditioner is monitored over Ethernet and if a problem is detected, an alarm is generated. The alarm is displayed on the CoolLinks PLC in the shelter **and** sent via SNMP trap to the network operations center.

- High Pressure Alarm – the refrigerant pressure has exceeded the set point pressure *once* in a cooling cycle. The air conditioner will continue to operate, but notification is sent that there is a high pressure fault.
- High Pressure Lockout Alarm - the refrigerant pressure has exceeded the set point pressure *twice* in a cooling cycle. The air conditioner will shut down and notification will be sent that there is a high pressure lockout.
- Low Pressure Alarm – the refrigerant pressure has dropped below the set point pressure *once* in a cooling cycle. The air conditioner will continue to operate, but notification is sent that there is a low pressure fault.
- Low Pressure Lockout Alarm - the refrigerant pressure has dropped below the set point pressure *twice* in a cooling cycle. The air conditioner will shut down and notification will be sent that there is a low pressure lockout.
- Damper Alarm – if the 100% full flow damper does not open when required, an alarm notification is sent that the damper is not open.
- Dirty Filter Alarm – a switch monitors the pressure on either side of the filter. If the differential pressure exceeds the set point pressure, an alarm notification is sent that there is not sufficient air flow through the filter.
- Communications Alarm – a signal is sent if there is a loss of communication between the air conditioner and the CoolLinks controller.

Shelter & System Alarms

- In addition to the HVAC alarms, the CoolLinks controller also provides Shelter and System alarms. The alarm is displayed on the CoolLinks PLC in the shelter **and** also sent via SNMP trap to the network operations center.
- First Stage High Temperature Alarm – Inside temperature above 85°F (29.4°C).
- Second Stage High Temperature Alarm – Inside temperature above 90°F (32.2°C).
- Low Temperature Alarm - Inside temperature is below 45°F (7.2°C).
- Landline Power Alarm – A loss of landline power.
- Smoke Alarm - If the smoke sensor input to the CoolLinks system is active, the Compressor, Heater, and Indoor Blower Motor on both HVAC units will be shut down and the damper will closed completely. This will stop air flow within the shelter.
- Hydrogen Detector Alarm- If the hydrogen sensor input to the CoolLinks system is active, the damper(s) on units that are not currently in mechanically cooling will be fully opened and the Indoor Blower Motor(s) will be turned on. This will expel noxious gases and introduce outside air into the shelter. If one unit is in mechanical cooling, it will continue to run. The other air conditioner will turn on and operate in the emergency ventilation mode.
- Generator Operation Alarm - If the generator running input to the CoolLinks system is active, only one HVAC unit will be permitted to run in mechanical cooling. As the generator is typically sized to run only one HVAC unit, this ensures that the generator load is not exceeded.

Remote Access Data Points

Through the Ethernet connection, the network operations center can monitor and change various data points in the HVAC system and the shelter.

Data Points which can be monitored **and** changed:

- First Stage Cooling Set Point Temperature
- Second Stage Cooling Set Point Differential Temperature
- First Stage Heating Set Point Temperature
- Second Stage Heating Set Point Differential Temperature

Data points which can only be monitored:

- Inside Temperature - Current
- Outside Temperature - Current
- Outside Humidity - Current
- Dew point - Current

- Inside Temperature - Average Last Hour
- Outside Temperature - Average Last Hour
- Outside Humidity - Average Last Hour
- Dew point - Average Last Hour

- Unit 1 & Unit 2 Mechanical Cooling Time - Last Hour
- Unit 1 & Unit 2 Mechanical Cooling Requests - Last Hour
- Unit 1 & Unit 2 DC Free Air Cooling Time - Last Hour
- Unit 1 & Unit 2 DC Free Air Cooling Requests - Last Hour
- Unit 1 & Unit 2 Heating Time - Last Hour
- Unit 1 & Unit 2 Heating Requests - Last Hour

Standard Features

Designed for Operation in Low Ambient Conditions

- Low ambient control cycles condenser fan to maintain proper refrigerant pressures. Allows operation in mechanical cooling (compressor) down to 0°F (-18°C). Note: low temperature operation is affected by ambient conditions, e.g. wind and humidity.
- Three minute by-pass of the low pressure switch for start-up of compressor when outdoor temperatures are below 55°F (13°C).
- Factory built-in economizer.

High Efficiency

- High efficiency compressor.
- Lanced fins standard on all evaporator and condenser coils.

Built-in Reliability

- High pressure switch and low pressure switch with lockout protects refrigerant circuit.
- Adjustable .03 to ten minute delay on make for short cycle protection.

Ease of Installation

- Sloped top with flashing eliminates need of rain hood.
- Built-in mounting flanges facilitate installation and minimize chance of water leaks.
- Supply and return openings exactly match previous models.
- Factory installed disconnect on all units.
- Single Point Power Entry complies with latest edition of U.L. Standard 1995.

Rugged Construction

- Copper tube, aluminum fin evaporator & condenser coils.
- Field or factory installed heaters on discharge side of evaporator coil (optional)
- Baked on neutral beige finish over galvanneal steel for maximum cabinet life. (Other finishes are available.)

Ease of Service

- Service access valves are standard.
- Standard 2" (50 mm) pleated filter with a MERV rating of 8 changeable from outside.
- All major components are readily accessible.
- Front Control Panel allows easy access and complies with NEC clearance codes on redundant side-by-side systems.
- LEDs indicate operational status and fault conditions.
- Foiled backed insulation on the indoor air path.
- A minimum position potentiometer that can be adjusted to prevent the economizer damper from closing completely. This control ensures that whenever the evaporator fan is operating, fresh air is being introduced into the building.

Kim: are these statements valid?

Grilles

For ASDCA36

Supply Grille:

28" x 8" (711mm x 203mm)..... P/N 80675

Return Grille:

20" x 12" (508mm x 356mm)..... P/N 80678

For ASDCA42-48-60-72

Supply Grille:

30" x 10" (762mm x 254mm)..... P/N 80676

Return Grille:

30" x 16" (762mm x 406mm)..... P/N 80679

Factory Installed Accessories

Phase Monitor - Monitors 3Ø power supply and will turn the air conditioner off if power supply is not phased properly. Not required on 1Ø units.

Compressor Sound Jacket - To reduce sound of compressor.

Right & Left Side Compressor Configuration –

The air conditioners can be built with the compressor on the opposite side to facilitate service access when two units are installed side by side. In the 36, the standard location for the compressor is on the right hand side. In the 42-48-60, the standard location for

the compressor is on the left hand side. In the 72, the compressor is accessed from the front of the unit and an opposing configuration is not required.

Hard Start Kit - Used on single phase equipment to give the compressor higher starting torque under low voltage conditions. (Field installed only) (Note: Not recommended for use on scroll compressors.)

Options

Coastal Environment Package – Recommended for units to be installed near an ocean or on seacoast. Includes corrosion resistant fasteners, sealed or partially sealed condenser fan motor, protective coating applied to all exposed internal copper and metal in the in the condenser section and an impregnated polyurethane on the condenser coil and fan blades. See Coastal Environmental Technical Bulletin for more details.

Protective Coil Coatings - Either the condenser or evaporator coil can be coated, however, coating of the evaporator coil is not common. For harsh conditions, e.g., power plants, paper mills or sites where the unit will be exposed to salt water, the coil should be coated. Note: Cooling capacity may be reduced by up to 5% on units with coated coils.

MODEL # - ASDCA48ACA050C-A2-100-VAR

Model Identification

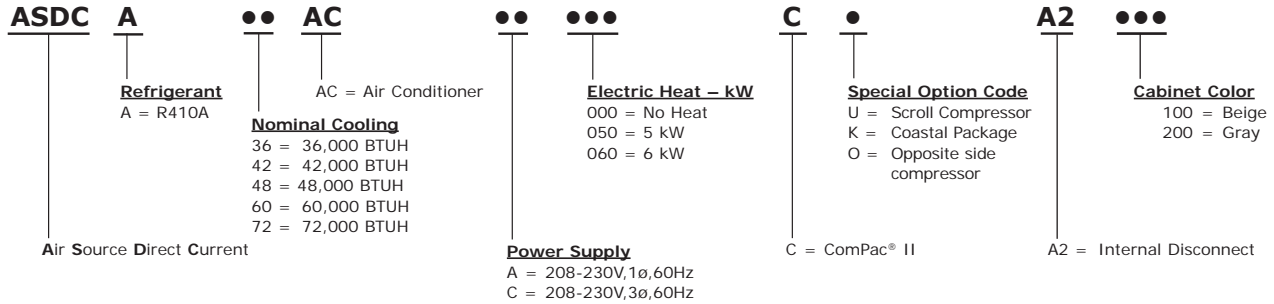

Electrical Characteristics - Compressor, Fan & Blower Motors

BASIC MODEL	COMPRESSOR			OUTDOOR FAN MOTOR				INDOOR BLOWER MOTORS				
	VOLTS / HZ / PH	RLA ¹	LRA ²	VOLTS / HZ / PH	RPM ³	FLA ⁴	HP ⁵	QTY	VDC ⁶	RPM ³	FLA ⁴	HP ⁵
ASDCA36ACA	208/230-60-1	14.7	84.0	208/230-60-1	1075	1.8	1/4	2	48	2070	4.4	1/6
ASDCA42ACA	208/230-60-1	15.7	84.0	208/230-60-1	825	2.8	1/3	2	48	1930	6.0	1/4
ASDCA48ACA	208/230-60-1	18.6	102.0	208/230-60-1	825	2.8	1/3	2	48	1930	6.0	1/4
ASDCA60ACA	208/230-60-1	23.0	130.0	208/230-60-1	825	2.8	1/3	2	48	1930	6.0	1/4
ASDCA72ACA	208/230-60-1	30.1	158.0	208/230-60-1	825	2.9	1/2	2	48	1930	6.0	1/4
ASDCA36ACC	208/230-60-3	13.2	88.0	208/230-60-1	1075	1.8	1/4	2	48	2070	4.4	1/6
ASDCA42ACC	208/230-60-3	13.6	83.1	208/230-60-1	825	2.8	1/3	2	48	1930	6.0	1/4
ASDCA48ACC	208/230-60-3	13.7	83.1	208/230-60-1	825	2.8	1/3	2	48	1930	6.0	1/4
ASDCA60ACC	208/230-60-3	15.6	111.0	208/230-60-1	825	2.8	1/3	2	48	1930	6.0	1/4
ASDCA72ACC	208/230-60-3	22.4	149.0	208/230-60-1	825	2.9	1/2	2	48	1930	6.0	1/4

¹RLA = Rated Load Amps ²LRA = Locked Rotor Amps ³RPM = Revolutions per Minute ⁴FLA = Full Load Amps ⁵HP = Horsepower ⁶VDC = Volts, DC

Summary Electrical Ratings (Wire and Circuit Breaker Sizing)

BASIC MODEL	VOLTAGE PHASE / HZ	000 = None		050 = 5 kw		060 = 6 kw	
		SPPE ³		SPPE ³		SPPE ³	
		MCA ¹	MFS ²	MCA ¹	MFS ²	MCA ¹	MFS ²
ASDCA36ACA	208/230-1-60	24.2	40	26.0	40		
ASDCA42ACA	208/230-1-60	27.6	45	27.6	45		
ASDCA48ACA	208/230-1-60	30.1	50	30.1	50		
ASDCA60ACA	208/230-1-60	35.6	60	35.6	60		
ASDCA72ACA	208/230-1-60	40.5	60	40.5	60		
ASDCA36ACC	208/230-3-60	18.3	30			18.3	30
ASDCA42ACC	208/230-3-60	19.8	30			19.8	30
ASDCA48ACC	208/230-3-60	19.9	30			19.9	30
ASDCA60ACC	208/230-3-60	22.3	35			22.3	35
ASDCA72ACC	208/230-3-60	30.9	50			30.9	50

¹MCA = Minimum Circuit Ampacity (Wiring Size Amps) ²MFS = Maximum Fuse Size ³SPPE = Single Point Power Entry
MCA & MFS are calculated at 230 volts on the ACA & ACC models. This chart should only be used as a guideline for estimating conductor size and overcurrent protection. For the requirements of specific units, always refer to the data label on the unit.

Unit Load Amps

BASIC MODEL NUMBER	VOLTAGE PHASE / HZ	CURRENT LOAD (MOTORS)		LOAD OF RESISTIVE HEATING - ELEMENTS ONLY (AMPS)	
		Compressor & Outdoor Fan VAC Amps	Indoor Blower DC Amps	TOTAL MAXIMUM HEATING AMPS (VAC) ALL HEATING ELEMENTS ARE ON A SEPARATE CIRCUIT	
				05 kW	06 kW
ASDCA36ACA	208/230-1-60	19.7	8.8	20.8	
ASDCA42ACA	208/230-1-60	22.6	12.0	20.8	
ASDCA48ACA	208/230-1-60	24.6	12.0	20.8	
ASDCA60ACA	208/230-1-60	29.0	12.0	20.8	
ASDCA72ACA	208/230-1-60	33.0	12.0	20.8	
ASDCA36ACC	208/230-3-60	15.0	8.8		14.4
ASDCA42ACC	208/230-3-60	16.4	12.0		14.4
ASDCA48ACC	208/230-3-60	16.5	12.0		14.4
ASDCA60ACC	208/230-3-60	18.4	12.0		14.4
ASDCA72ACC	208/230-3-60	25.3	12.0		14.4

Heating kW is rated at 240 volts Total heating and cooling amps includes all VAC motors.
Loads are not equally balanced on each phase and values shown are maximum phase loads. Three phase models contain single phase motor loads.
Derate heater output by 25% for operation at 208 volts.

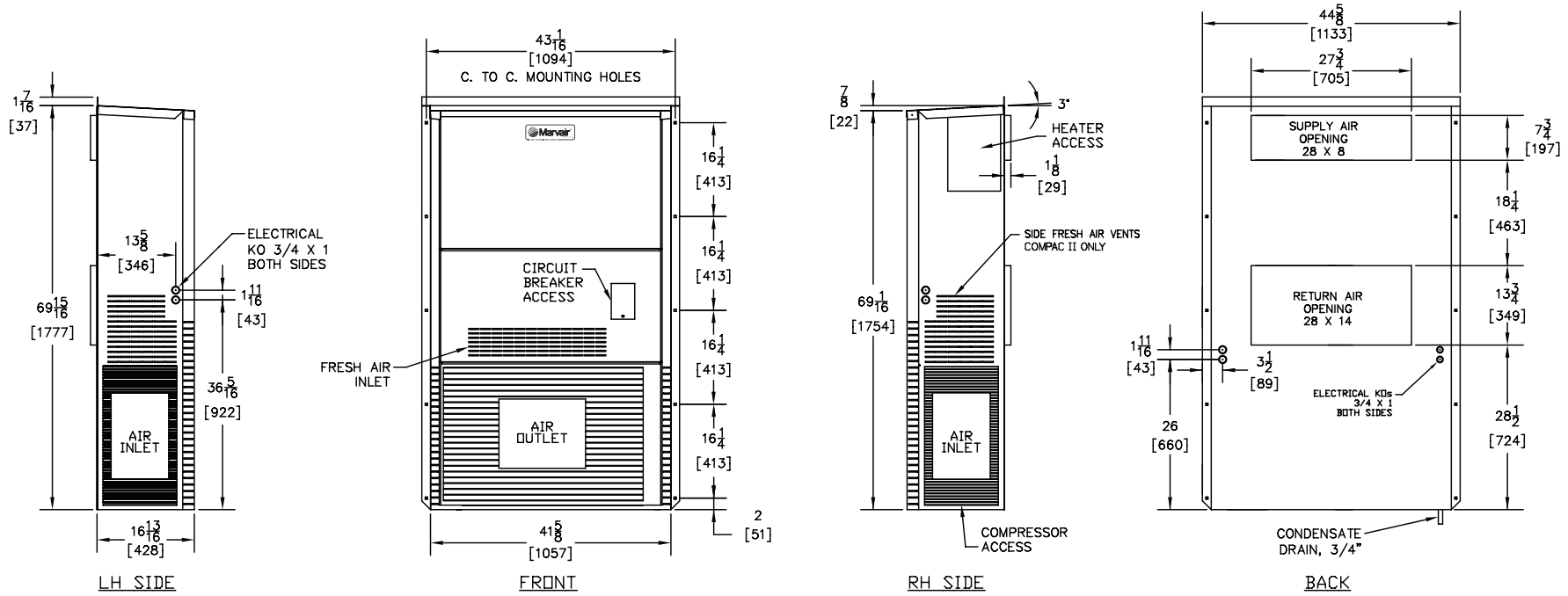

BOTTOM MOUNTING BRACKET

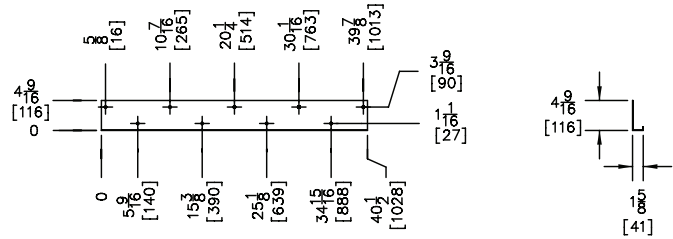

Shipping Weight (pounds/kilograms)

ASDCA36	LBS/KGS
COMPAC II	410/186.4

Filter Size

ASDCA36	INCHES	MILLIMETERS	PART NUMBER	FILTERS PER UNIT	MERV RATING
RETURN AIR FILTER	30 x 16 x 2	762 x 406 x 51	92486	1	8

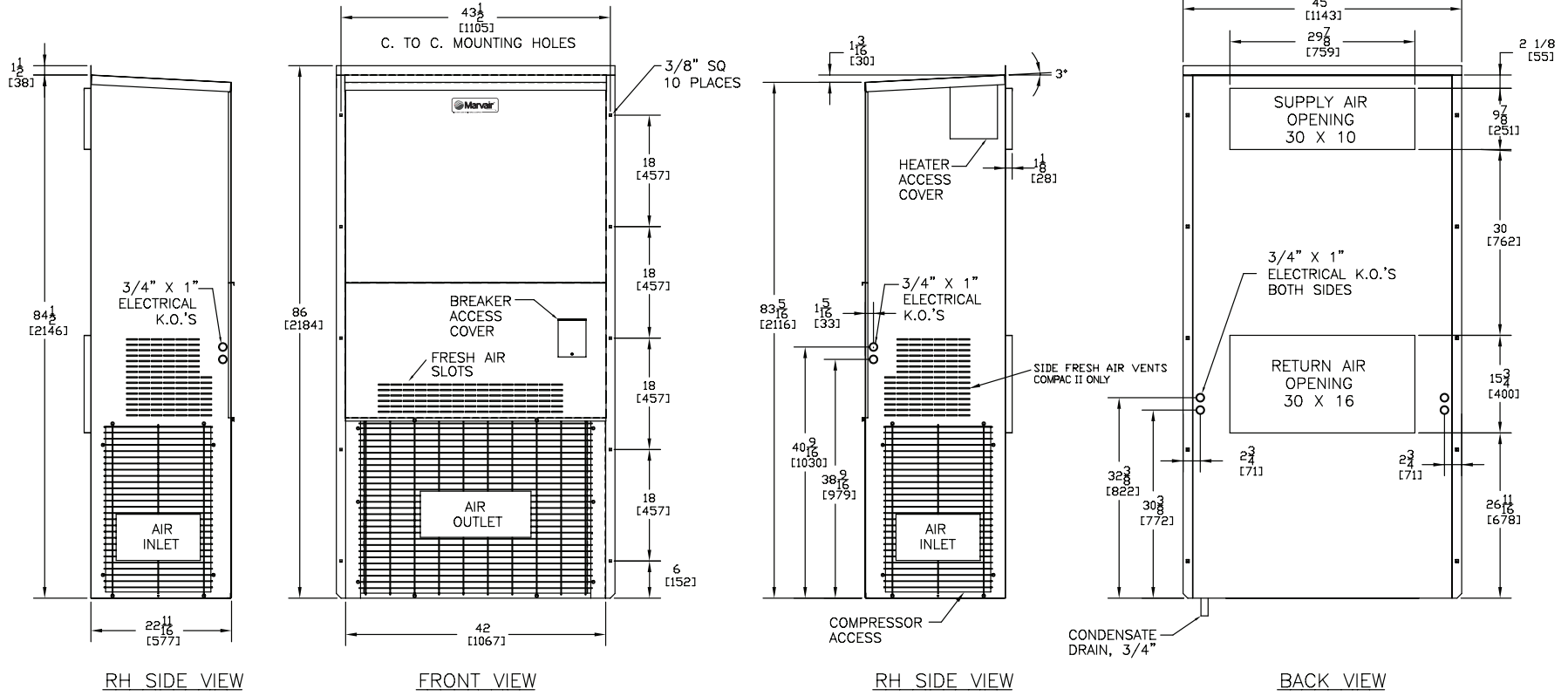

BOTTOM MOUNTING BRACKET

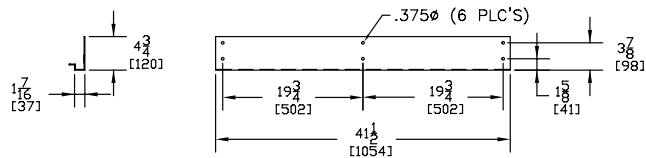

Shipping Weight (pounds/kilograms)

ASDCA42-48-60	LBS/KGS
COMPAC II	590/268

Filter Size

ASDCA42-48-60	INCHES	MILLIMETERS	PART NUMBER	FILTERS PER UNIT	MERV RATING
RETURN AIR FILTER	36½ x 22 x 2	927 x 559 x 51	80162	1	8

Dimensional Data - ASDCA72

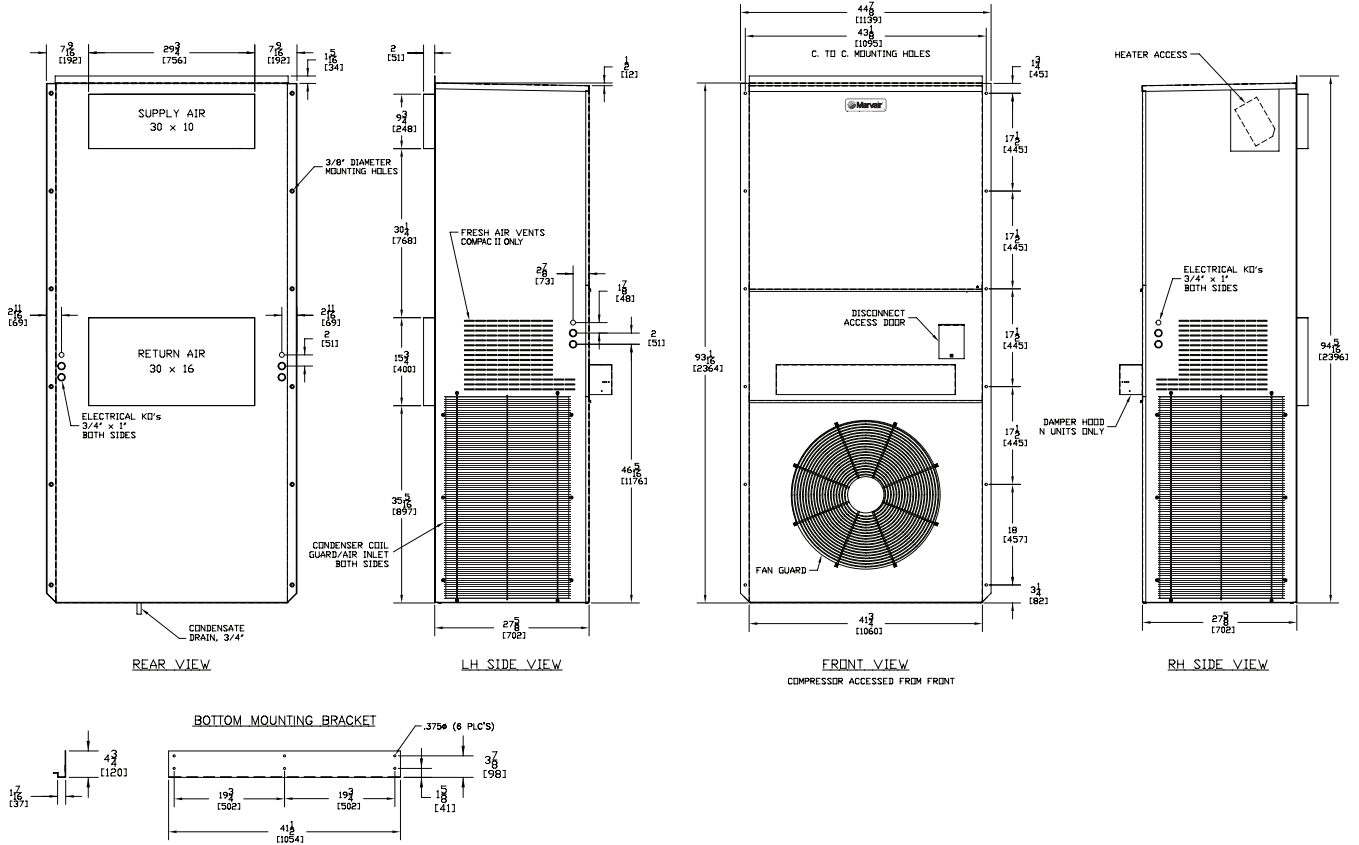

Shipping Weight (pounds/kilograms)

ASDCA72	LBS/KGS
COMPAC II	640/291

Filter Size

ASDCA72	INCHES	MILLIMETERS	PART NUMBER	FILTERS PER UNIT	MERV RATING
RETURN AIR FILTER	18 x 24 x 2	457 x 610 x 51	TBD	2	8



Please consult the Marvair® website at www.marvair.com for the latest product literature. Detailed dimensional data is available upon request. A complete warranty statement can be found in each product's Installation/Operation Manual, on our website or by contacting Marvair at 229-273-3636. As part of the Marvair continuous improvement program, specifications are subject to change without notice.



P.O. Box 400 • Cordele, GA 31010
 156 Seedling Drive • Cordele, GA 31015
 Ph: 229-273-3636 • Fax: 229-273-5154
 Email: marvair@airxcel.com • Internet: www.marvair.com



Supplement to the ComPac Product Manual for the ASDC air conditioners

This supplement to the ComPac Product Manual describes the 48 VDC wiring, the connection of the Ethernet cable (page 2) and the CoolLinks™ Operator Interface Instructions (page 3) for the ASDCA air conditioners. These air conditioners require a 48 Volt DC power to operate the evaporator air movers and the free cooling damper motor.

48 VDC wiring

1. If the air conditioners are powered, remove AC **and** DC power to the air conditioners by switching the breakers **in the shelter** to the OFF position.
2. Size a 2 conductor wire cable per NEC standard taking into account the ampacity of the DC circuit listed on the rating plate and the location of the power supply. Connect the properly sized cable between a DC breaker in the shelter and the DC breaker in the air conditioner. The DC breaker in the air conditioner is located on the right side of the bank of breakers.
3. Turn on the DC breaker in the shelter.
4. Verify the polarity and the voltage to make sure the polarity is correct and that there is 48 VDC at the breaker in the air conditioner. If the polarity is not correct, switch the wires.
5. Turn on the DC breaker in the air conditioner.
(See photos on following page.)

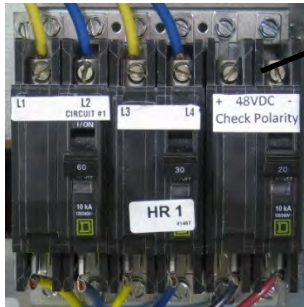
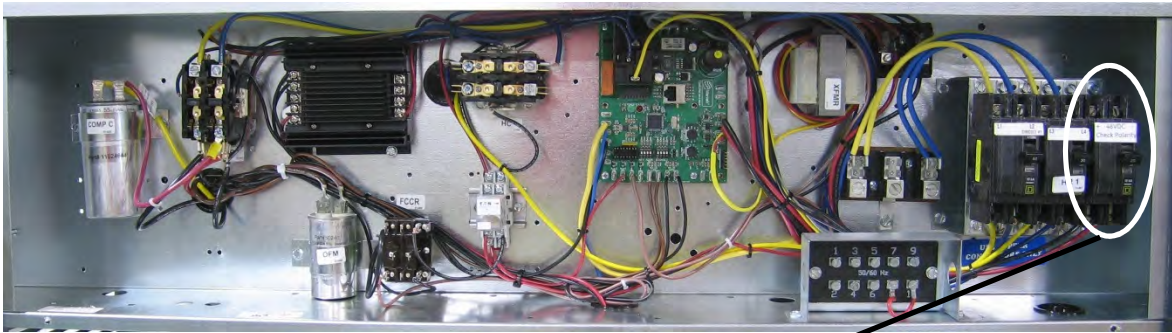

Connection of PLC controller board in shelter to CoolLinks™ board in the air conditioner

Route a standard Cat 5e Ethernet cable from the PC board in the air conditioner to the PLC controller in the shelter. If the cable is routed through the air stream, it must be plenum rated. When the PLC is configured, the air conditioners will be designated as AC #1 and AC#2.

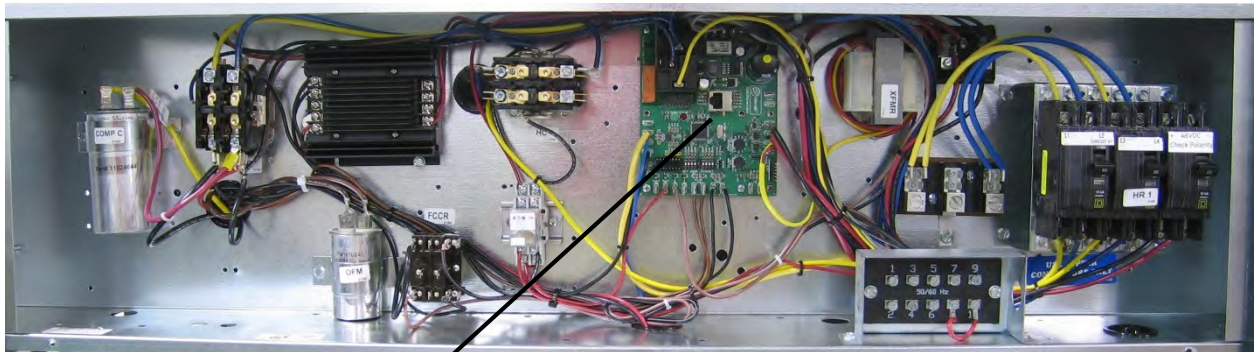

CoolLinks Ethernet jack



Operator Interface Instructions

System Status

The main screen displays the status of the Marvair CoolLinks system and the two Marvair HVAC units. Standing inside the shelter facing the HVAC return air vents, unit 1 is the left-hand unit and unit 2 is the right-hand unit. The fields on the status screen are as follows:

Indoor Temperature:	Indoor temperature from the temperature sensor mounted on the wall between the HVAC return air grilles. This sensor controls the enabling/disabling of the cooling/heating.
IBM Pushbutton:	Indicates the status of the Indoor Blower Motor (IBM) as Running or Stopped. If the blower motor is not under automatic control, pressing the pushbutton will turn the motor on and off. Press once to turn on and press again to turn off. The motor is under automatic control whenever the HVAC unit is the lead unit, during cooling post-purge, free-air operation, and emergency ventilation.
Unit Status Panel:	Indicates the status of the HVAC unit as follows: <ul style="list-style-type: none">• Lead Yes: unit is lead unit, No: unit is lag unit• Cool Yes: unit is cooling, No: unit is not cooling• Heat Yes: unit is heating, No: unit is not heating• Filter Ok: filter is good, Maint: filter is blocked• Comm Yes: PLC comms active, No: PLC comms fault
Lead Swap Pushbutton:	Swap the lead and lag unit. Note that if the lag unit is in lockout or has a comms fault, the system will not swap. If the lead unit experiences a lockout or



comms failure, the system will automatically swap to the lag unit.

Comfort Mode Pushbutton: Drop the first-stage cooling set point to 75°F to allow a service technician to work comfortably inside the shelter. After one hour the set point will return to its previous value. Comfort mode is also cancelled if the technician enters a new first-stage cooling set point.

Reset Lockout Pushbutton: Resets the lockout condition on whichever unit is in lockout. Note that a call for cooling must be active before the lockout can be reset.

Outdoor Air: Outside air temperature (°F).

Humidity: Outside air relative humidity (%).

Dew Point: Dew point temperature (°F). When the calculated dew point (based on outside air temperature and relative humidity) is below the maximum dew point temperature and the free-air enable temperature, and the outside air temperature is below the indoor air temperature, then enable free-air cooling.

Alarm Message: Active unit alarms are displayed in the alarm message window between the IBM (Indoor blower Motor) pushbutton and the unit status panel. If multiple alarms are present the system scrolls through the active alarms with each alarm displayed for five seconds. If no alarms are present, the message window is blank. Thirteen possible alarm messages may be displayed:

- High Pressure Switch Alarm
- Low Pressure Switch Alarm
- High Pressure Switch Lockout Alarm
- Low Pressure Switch Lockout Alarm
- 1st High Indoor Temperature Alarm (> 85°F)



- 2nd High Indoor Temperature Alarm (> 90°F)
- Low Indoor Temperature Alarm (< 45°F)
- Landline Power Alarm
- Damper Alarm
- Smoke Alarm
- Generator Running
- Hydrogen Alarm
- Communications Alarm

The main screen with each of the operator/display fields is presented below. Note that the six function keys at the bottom of the screen are not currently assigned and have no effect on the operation of the Marvair CoolLinks system.

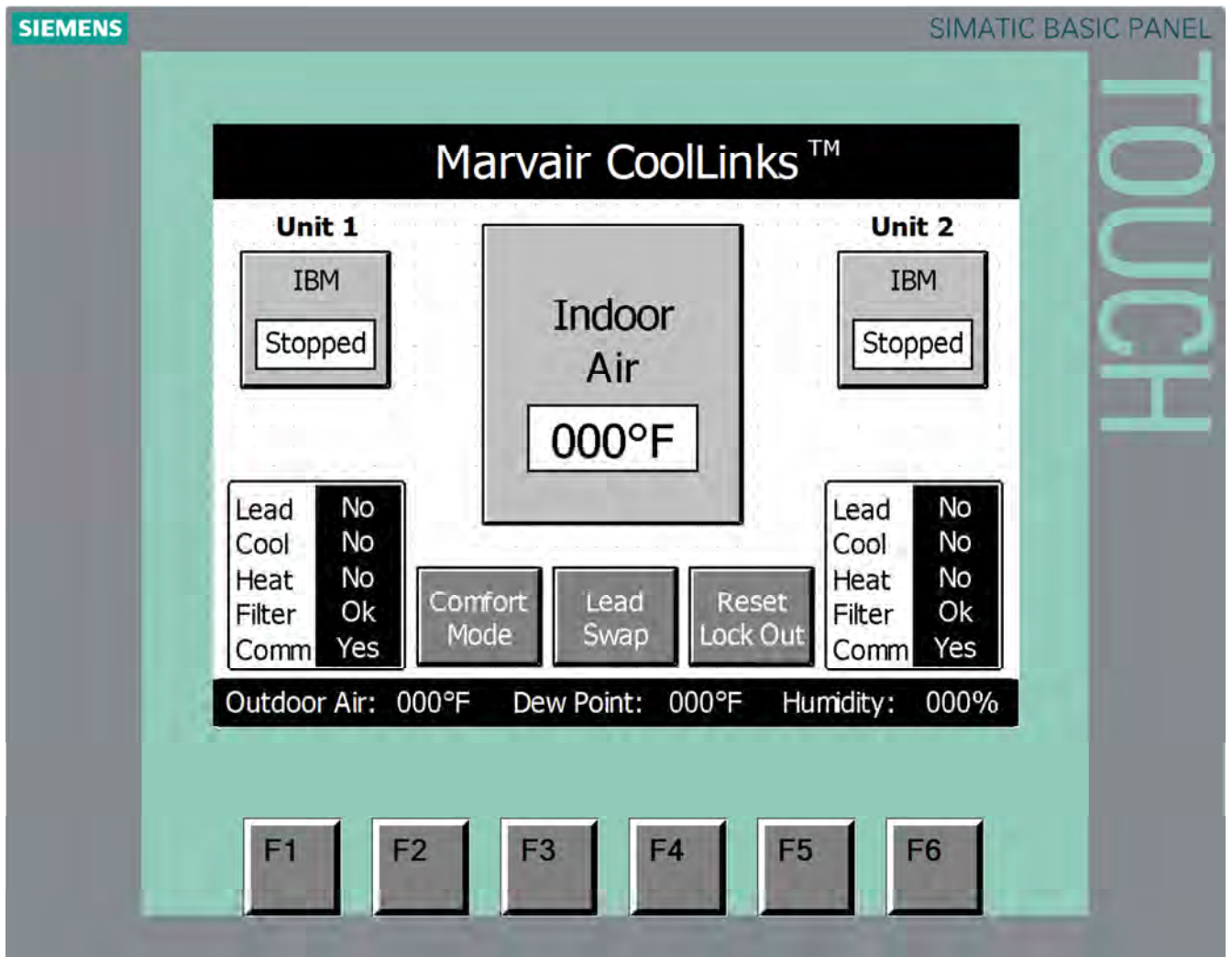



Changing Set Points

Set points control the cooling and heating operation of the Marvair CoolLinks system. Basically, there are two groups of set points, cooling first and second stage set points, and heating first and second stage set points. The minimum set point for cooling is 50°F and the maximum set point for heating is 90°F. To access these set points, simply touch the top or bottom of the Indoor Temperature display. This will then enable the set point control panel. If a new set point value is not entered within ten seconds, the display will revert back to the Indoor Temperature display. From the set point control panel, alter the set points as follows:

Cooling First Stage:

Press the Cooling push-button then press the 1st Stage push-button. Both push buttons will turn dark gray with white text and the current cooling first-stage set point value will be displayed. Next, press the set point value to display the numeric entry screen and enter the desired set point. The system will now enable cooling whenever the indoor temperature is 1° F above the set point and disable cooling when the indoor temperature drops to 2° F below the set point.

Cooling Second Stage:

Press the Cooling push-button then press the 2nd Stage push-button. Both push buttons will turn dark gray with white text and the current cooling second-stage set point value will be displayed. Next, press the set point value to display the numeric entry screen and enter the differential set point. The system will now enable second-stage cooling whenever the indoor temperature is 1° F higher than the first-stage cooling set point plus the second stage cooling differential and disable second-stage cooling when the indoor temperature drops to 2° F below the first-stage set point. It is strongly recommend that the second-stage cooling differential be set to a minimum of 5° F to allow the first-stage cooling time to operate fully and to prevent short-cycling of the second unit.



Cooling Example:

First-Stage Set Point: 78°F

Second-Stage Differential: 5°F

First-stage cooling will start when the indoor temperature reaches 79°F (set point + 1°F) and will stop when the indoor temperature reaches 76°F (set point – 2°F).

Second-stage cooling will start when the indoor temperature reaches 84°F (set point + 1°F + 5°F) and will stop when the indoor temperature reaches 76°F (set point – 2°F).

Note that once first-stage cooling is enabled, the unit will run for at least **five minutes** even if the indoor temperature reaches the disable temperature. This is to prevent short-cycling of the unit and to allow the compressor sufficient time to remove moisture from the air as well cool the shelter.

Heating First Stage:

Press the Heating push-button then press the 1st Stage push-button. Both push buttons will turn dark gray with white text and the current heating first-stage set point value will be displayed. Next, press the set point value to display the numeric entry screen and enter the desired set point. The system will now enable heating whenever the indoor temperature is 1°F below the set point and disable heating when the indoor temperature rises to 1° F above the set point.

Heating Second Stage:

Press the Heating push-button then press the 2nd Stage push-button. Both push buttons will turn dark gray with white text and the current heating second-stage set point value will be displayed. Next, press the set point value to display the numeric entry screen and enter the differential set point. The system will now enable second-stage heating whenever the indoor temperature is 1° F lower than the first-stage heating set point minus the second stage heating differential and disable second-stage heating when the indoor temperature rises to 1° F above the first-stage set point. It is strongly recommend that the second-stage heating differential be set to a minimum of



two degrees F to allow the first-stage heating time to operate fully and to prevent short-cycling of the second unit.

Heating Example:

First-Stage Set Point: 60°F

Second-Stage Differential: 2°F

First-stage heating will start when the indoor temperature reaches 59°F (set point – 1°F) and will stop when the indoor temperature reaches 61°F (set point + 1°F).

Second-stage heating will start when the indoor temperature reaches 57°F (set point – 1° - 2°F) and will stop when the indoor temperature reaches 61°F (set point + 1°F).

The main screen with the set point control panel is presented below. Note that if the cooling and heating temperature set points overlap, the system will only allow cooling to be active. As with the status screen, the six function keys at the bottom of the screen are not currently assigned and have no effect on the operation of the Marvair CoolLinks system.

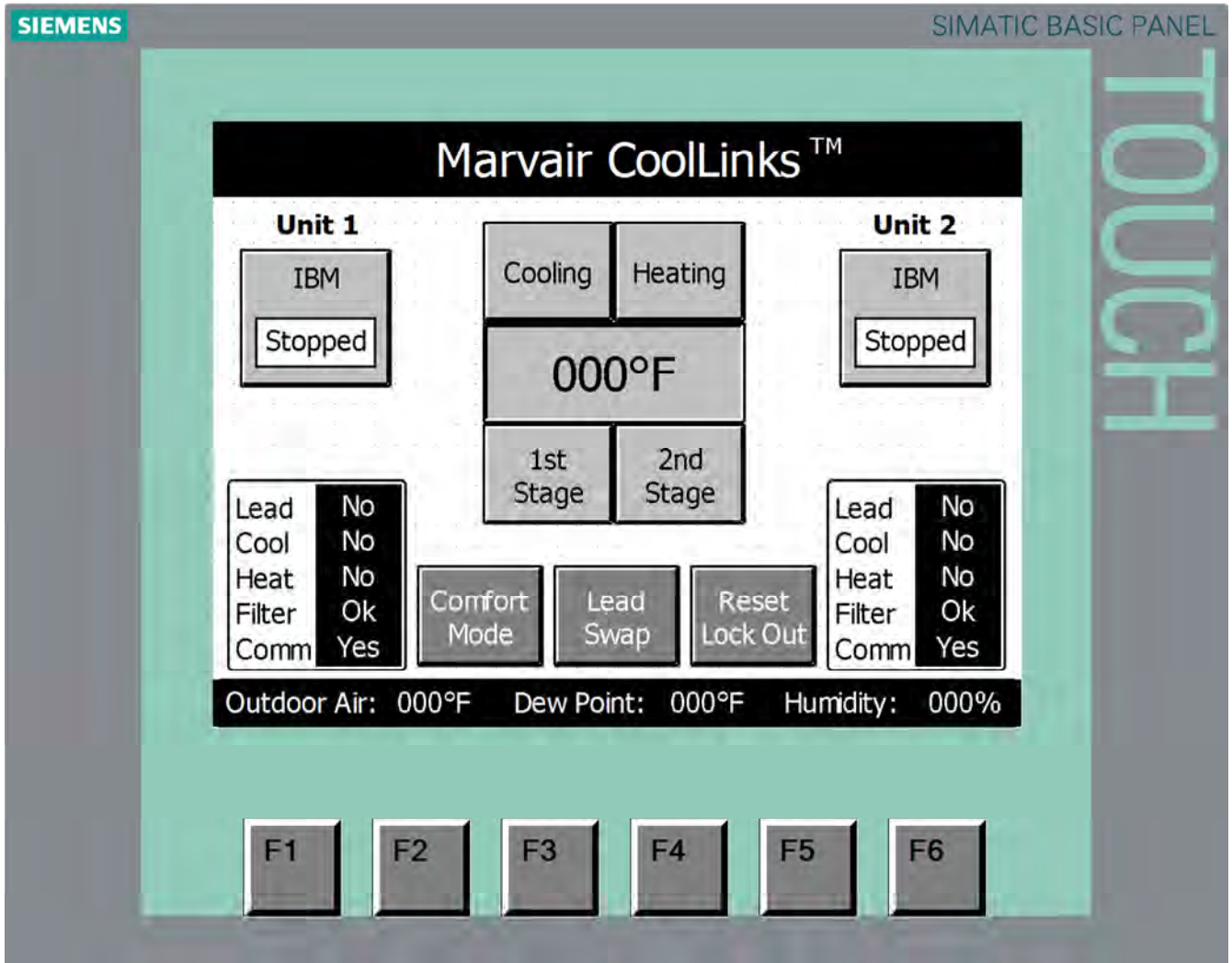

DC Free-Air Cooling

When the outside temperature and humidity are below acceptable limits, mechanical cooling is disabled and outside air is introduced to cool the shelter. The position of the damper is first opened to 100% then regulated to maintain a mixed air temperature of 55°F. This set point is user-selectable on the CoolLinks HVAC board for 55°, 57°, 59°, or 61°F. Both the damper and the Indoor Blower Motor are powered by 48 VDC. Every twenty-four hours, the damper is opened to 25% to verify the operation of damper motor, damper fault switch, and damper actuator linkage.



Emergency Ventilation

The Marvair CoolLinks system will enable emergency ventilation if landline power is lost or if both HVAC units are in lockout. In this situation, the system will fully open the damper and run the Indoor Blower Motor on each HVAC unit. The system will also try to modulate the damper position to maintain a mixed air temperature of 55°F).

Smoke Detection

If the smoke sensor input to the CoolLinks system is active, the Compressor, Heater, and Indoor Blower Motor on both HVAC units will be shut down and the damper will be fully closed. This is to halt the flow of air within the shelter.

Hydrogen Detection

If the hydrogen sensor input to the CoolLinks system is active, the damper(s) on units that are not currently mechanically cooling will be fully opened and the Indoor Blower Motor(s) will be turned on. The intention here is to expel noxious gases and to introduce outside air into the shelter.

Generator Running

If the generator running input to the CoolLinks system is active, only one HVAC unit will be permitted to run mechanical cooling. As the generator is sized to run only one HVAC unit, this ensures that the generator load is not exceeded.

Note: When in generator run mode, the HVAC unit is **not** allowed to operate in the DC Free-Air Cooling mode. This prevents "wet stacking" of the generator because the engine would be running at a small percentage of its capacity.

STANDBY POWER RATING

35 kW, 44 kVA, 60 Hz

PRIME POWER RATING*

32 kW, 39 kVA, 60 Hz

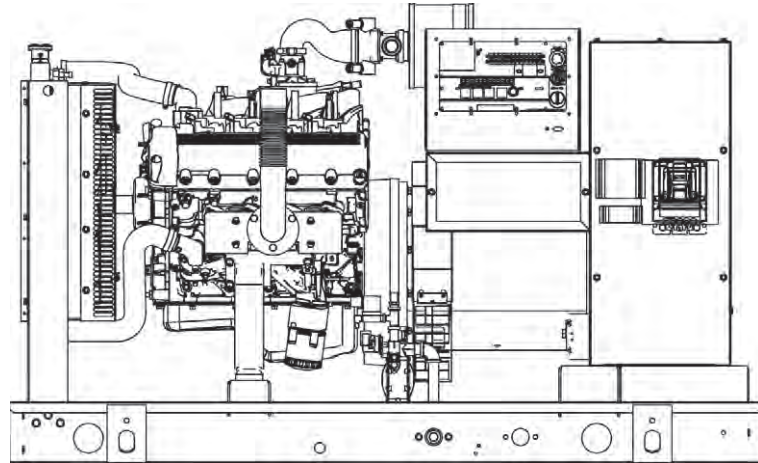

*Built in the USA using domestic and foreign parts

*EPA Certified Prime ratings are not available in the U.S. or its Territories.

Image used for illustration purposes only

CODES AND STANDARDS

Generac products are designed to the following standards:

 UL2200, UL508, UL142, UL498

 NFPA70, 99, 110, 37

 NEC700, 701, 702, 708

 ISO9001, 8528, 3046, 7637, Pluses #2b, 4

 NEMA ICS10, MG1, 250, ICS6, AB1

 **ANSI**
 American National Standards Institute
 ANSI C62.41

 **ICC** **osHPD**
 IBC 2009, CBC 2010, IBC 2012, ASCE 7-05,
 ASCE 7-10, ICC-ES AC-156 (2012)

POWERING AHEAD

For over 50 years, Generac has led the industry with innovative design and superior manufacturing.

Generac ensures superior quality by designing and manufacturing most of its generator components, including alternators, enclosures and base tanks, control systems and communications software.

Generac's gensets utilize a wide variety of options, configurations and arrangements, allowing us to meet the standby power needs of practically every application.

Generac searched globally to ensure the most reliable engines power our generators. We choose only engines that have already been proven in heavy-duty industrial application under adverse conditions.

Generac is committed to ensuring our customers' service support continues after their generator purchase.

STANDARD FEATURES

ENGINE SYSTEM

General

- Oil Drain Extension
- Air Cleaner
- Fan Guard
- Stainless Steel flexible exhaust connection
- Factory Filled Oil & Coolant
- Radiator Duct Adapter (open set only)
- Critical Exhaust Silencer (enclosed only)

Fuel System

- Flexible fuel line NPT Connection
- Primary and secondary fuel shutoff

Cooling System

- Closed Coolant Recovery System
- UV/Ozone resistant hoses
- Factory-Installed Radiator
- 50/50 Ethylene glycol antifreeze
- Radiator drain extension

Engine Electrical System

- Battery charging alternator
- Battery cables
- Battery tray
- Rubber-booted engine electrical connections
- Solenoid activated starter motor

ALTERNATOR SYSTEM

- UL2200 Genprotect™
- Class H insulation material
- 2/3 Pitch
- Skewed Stator
- Brushless Excitation
- Sealed Bearings
- Amortisseur winding
- Full load capacity alternator

GENERATOR SET

- Internal Genset Vibration Isolation
- Separation of circuits - high/low voltage
- Separation of circuits - multiple breakers
- Wrapped Exhaust Piping
- Standard Factory Testing
- 2 Year Limited Warranty (Standby rated Units)
- 1 Year Warranty (Prime rated units)
- Silencer mounted in the discharge hood (enclosed only)

ENCLOSURE (IF SELECTED)

- Rust-proof fasteners with nylon washers to protect finish
- High performance sound-absorbing material (L1 & L2)
- Gasketed doors
- Stamped air-intake louvers
- Air discharge hoods for radiator-upward pointing
- Stainless steel lift off door hinges
- Stainless steel lockable handles
- Rhino Coat™ - Textured polyester powder coat

CONTROL SYSTEM



Control Panel

- Digital H Control Panel - Dual 4x20 Display
- Programmable Crank Limiter
- 7-Day Programmable Exerciser
- Special Applications Programmable PLC
- RS-232/485
- All-Phase Sensing DVR
- Full System Status
- Utility Monitoring
- Low Fuel Pressure Indication
- 2-Wire Start Compatible
- Power Output (kW)
- Power Factor
- kW Hours, Total & Last Run

- Real/Reactive/Apparent Power
- All Phase AC Voltage
- All Phase Currents
- Oil Pressure
- Coolant Temperature
- Coolant Level
- Engine Speed
- Battery Voltage
- Frequency
- Date/Time Fault History (Event Log)
- Isochronous Governor Control
- Waterproof/sealed Connectors
- Audible Alarms and Shutdowns
- Not in Auto (Flashing Light)
- Auto/Off/Manual Switch
- E-Stop (Red Mushroom-Type)
- NFPA110 Level I and II (Programmable)
- Customizable Alarms, Warnings, and Events
- Modbus protocol
- Predictive Maintenance algorithm
- Sealed Boards
- Password parameter adjustment protection

- Single point ground
- 15 channel data logging
- 0.2 msec high speed data logging
- Alarm information automatically comes up on the display

Alarms

- Oil Pressure (Pre-programmable Low Pressure Shutdown)
- Coolant Temperature (Pre-programmed High Temp Shutdown)
- Coolant Level (Pre-programmed Low Level Shutdown)
- Low Fuel Pressure Alarm
- Engine Speed (Pre-programmed Over speed Shutdown)
- Battery Voltage Warning
- Alarms & warnings time and date stamped
- Alarms & warnings for transient and steady state conditions
- Snap shots of key operation parameters during alarms & warnings
- Alarms and warnings spelled out (no alarm codes)

CONFIGURABLE OPTIONS

ENGINE SYSTEM

General

- Engine Block Heater
- Oil Heater
- Air Filter Restriction Indicator
- Stone Guard (Open Set Only)
- Critical Exhaust Silencer (Open Set Only / Standard on Ultra Low Emissions Option)

Fuel Electrical System

- 10A & 2.5A UL battery charger
- Battery Warmer

ALTERNATOR SYSTEM

- Alternator Upsizing
- Anti-Condensation Heater
- Tropical Coating
- Permanent Magnet Excitation

CIRCUIT BREAKER OPTIONS

- Main Line Circuit Breaker
- 2nd Main Line Circuit Breaker
- Shunt Trip and Auxiliary Contact
- Electronic Trip Breaker

ENGINEERED OPTIONS

ENGINE SYSTEM

- Fluid containment Pans
- Coolant heater ball valves

ALTERNATOR SYSTEM

- 3rd Breaker Systems

CONTROL SYSTEM

- Spare inputs (x4) / outputs (x4) - H Panel Only
- Battery Disconnect Switch

GENERATOR SET

- Gen-Link Communications Software (English Only)
- Extended Factory Testing (3 Phase Only)
- IBC Seismic Certification
- 8 Position Load Center
- 2 Year Extended Warranty
- 5 Year Warranty
- 5 Year Extended Warranty

ENCLOSURE

- Standard Enclosure
- Level 1 Sound Attenuation
- Level 2 Sound Attenuation
- Steel Enclosure
- Aluminum Enclosure
- 150 MPH Wind Kit
- 12 VDC Enclosure Lighting Kit
- 120 VAC Enclosure Lighting Kit
- AC/DC Enclosure Lighting Kit
- Door Alarm Switch

GENERATOR SET

- Special Testing
- Battery Box

ENCLOSURE

- Motorized Dampers
- Enclosure Ambient Heaters

CONTROL SYSTEM

- 21-Light Remote Annunciator
- Remote Relay Board (8 or 16)
- Oil Temperature Sender with Indication Alarm
- Remote E-Stop (Break Glass-Type, Surface Mount)
- Remote E-Stop (Red Mushroom-Type, Surface Mount)
- Remote E-Stop (Red Mushroom-Type, Flush Mount)
- Remote Communication - Bridge
- Remote Communication - Ethernet
- 10A Run Relay
- Ground Fault Indication and Protection Functions

RATING DEFINITIONS

Standby - Applicable for a varying emergency load for the duration of a utility power outage with no overload capability.

Prime - Applicable for supplying power to a varying load in lieu of utility for an unlimited amount of running time. A 10% overload capacity is available for 1 out of every 12 hours. The Prime Power option is only available on International applications. Power ratings in accordance with ISO 8528-1, Second Edition

APPLICATION AND ENGINEERING DATA

ENGINE SPECIFICATIONS

General

Make	Generac
Cylinder #	8
Type	V
Displacement - L (cu In)	5.4L (329.53)
Bore - mm (in)	90.17 (3.55)
Stroke - mm (in)	105.92 (4.17)
Compression Ratio	9:1
Intake Air Method	Naturally Aspirated
Number of Main Bearings	4
Connecting Rods	Forged
Cylinder Head	Aluminum
Cylinder Liners	No
Ignition	Single Fire
Piston Type	Aluminum Alloy
Crankshaft Type	Nodular Iron
Lifter Type	Hydraulic
Intake Valve Material	Steel Alloy
Exhaust Valve Material	Hardened Steel
Hardened Valve Seats	Yes

Engine Governing

Governor	Electronic
Frequency Regulation (Steady State)	±0.25%

Lubrication System

Oil Pump Type	Gear
Oil Filter Type	Full-flow sping-on cartridge
Crankcase Capacity - L (qts)	5.7 (6)

Cooling System

Cooling System Type	Pressurized Closed Recovery
Water Pump Flow -gal/min (l/min)	38 (144)
Fan Type	Pusher
Fan Speed (rpm)	2143
Fan Diameter mm (in)	508 (20)
Coolant Heater Wattage	1500
Coolant Heater Standard Voltage	120 V

Fuel System

Fuel Type	Natural Gas, Propane Vapor
Carburetor	Down Draft
Secondary Fuel Regulator	Standard
Fuel Shut Off Solenoid	Standard
Operating Fuel Pressure	7" - 11" H ₂ O

Engine Electrical System

System Voltage	12 VDC
Battery Charging Alternator	Standard
Battery Size	See Battery Index 0161970SBY
Battery Voltage	12 VDC
Ground Polarity	Negative

ALTERNATOR SPECIFICATIONS

Standard Model	390mm
Poles	4
Field Type	Revolving
Insulation Class - Rotor	H
Insulation Class - Stator	H
Total Harmonic Distortion	<5%
Telephone Interference Factor (TIF)	<50

Standard Excitation	Brushless
Bearings	Sealed Ball
Coupling	Flexible Disc
Prototype Short Circuit Test	Yes
Voltage Regulator Type	Full Digital
Number of Sensed Phases	All
Regulation Accuracy (Steady State)	±0.25%

OPERATING DATA

POWER RATINGS

		Natural Gas	Propane Vapor
Single-Phase 120/240 VAC @1.0pf	35 kW	Amps: 146	Amps: 146
Three-Phase 120/208 VAC @0.8pf	35 kW	Amps: 121	Amps: 121
Three-Phase 120/240 VAC @0.8pf	35 kW	Amps: 105	Amps: 105
Three-Phase 277/480 VAC @0.8pf	35 kW	Amps: 53	Amps: 53
Three-Phase 347/600 VAC @0.8pf	35 kW	Amps: 42	Amps: 42

STARTING CAPABILITIES (sKVA)

sKVA vs. Voltage Dip

	kW	480 VAC						208/240 VAC					
		10%	15%	20%	25%	30%	35%	10%	15%	20%	25%	30%	35%
Standard	35	24	36	48	60	72	84	18	27	36	45	54	63
Upsize 1	40	27	41	54	68	81	95	20	31	41	51	61	71
Upsize 2	50	34	52	69	86	103	120	26	39	52	65	77	90
Upsize 3	60	42	63	83	104	125	146	32	47	62	78	94	110

FUEL CONSUMPTION RATES*

Natural Gas - ft ³ /hr (m ³ /hr)			Propane Vapor - ft ³ /hr (m ³ /hr)		
Percent Load	Standby		Percent Load	Standby	
25%	239 (6.8)		25%	79.7 (2.3)	
50%	409 (11.6)		50%	136.6 (3.9)	
75%	553 (15.7)		75%	184.4 (5.2)	
100%	682 (19.3)		100%	227.7 (6.4)	

* Fuel supply installation must accommodate fuel consumption rates at 100% load.

COOLING

		Standby
Air Flow (inlet air combustion and radiator)	ft ³ /min(m ³ /min)	2460 (69.7)
Coolant Flow per Minute	gal/min (l/min)	38 (144)
Coolant System Capacity	gal (l)	3 (11.36)
Heat Rejection to Coolant	BTU/hr	144,000
Max. Operating Air Temp on Radiator	°F (°C)	122 (50)
Max. Operating Ambient Temperature (before derate)	°F (°C)	110 (43.3)
Maximum Radiator Backpressure	in H ₂ O	0.5

COMBUSTION AIR REQUIREMENT

	Standby
Flow at Rated Power cfm (m ³ /min)	87 (2.5)

ENGINE

		Standby
Rated Engine Speed	rpm	1800
Horsepower at Rated kW**	hp	54
Piston Speed	ft/min	1251
BMEP	psi	72

EXHAUST

		Standby
Exhaust Flow (Rated Output)	cfm (m ³ /min)	260 (7.4)
Max. Backpressure (Post Turbo)	inHg (Kpa)	1.5 (5.1)
Exhaust Temp (Rated Output - post silencer)	°F (°C)	900 (482)
Exhaust Outlet Size (Open Set)	mm (in)	63.5 (2.5)

** Refer to "Emissions Data Sheet" for maximum bHP for EPA and SCAQMD permitting purposes.

Deration – Operational characteristics consider maximum ambient conditions. Derate factors may apply under atypical site conditions. Please consult a Generac Power Systems Industrial Dealer for additional details. All performance ratings in accordance with ISO3046, BS5514, ISO8528 and DIN6271 standards.

DIMENSIONS AND WEIGHTS

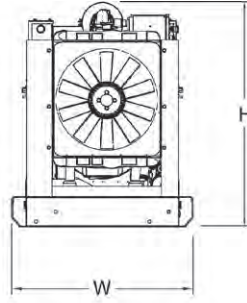
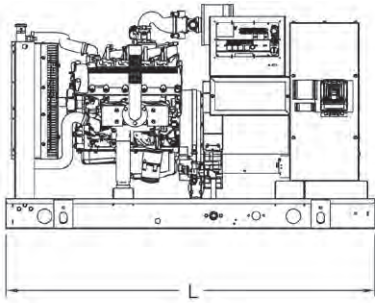

OPEN SET (Includes Exhaust Flex)

L x W x H in (mm)	76 (1930) x 37.4 (949.9) x 46 (1176)
Weight lbs (kg)	2199 (997)

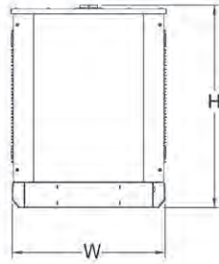
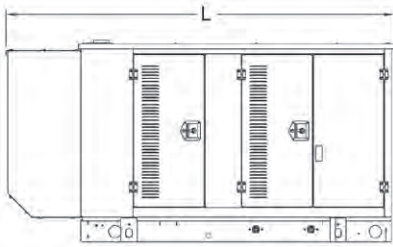

STANDARD ENCLOSURE

L x W x H in (mm)	94.8 (2408.9) x 38 (965.1) x 49.5 (1258.1)
Weight lbs (kg)	Steel: 2639 (1197) Aluminum: 2417 (1096)

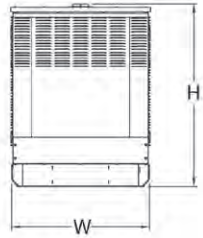
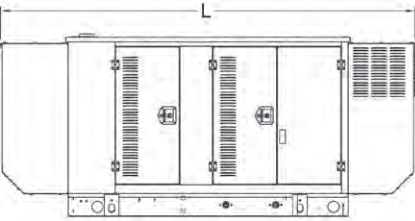

LEVEL 1 ACOUSTIC ENCLOSURE

L x W x H in (mm)	112.5 (2857.1) x 38 (965.1) x 49.5 (1258.1)
Weight lbs (kg)	Steel: 2719 (1233) Aluminum: 2451 (1112)

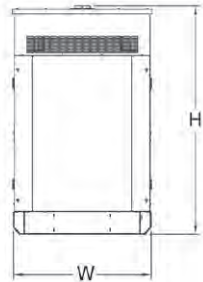
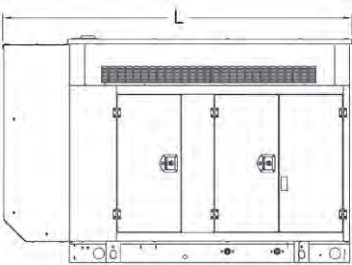

LEVEL 2 ACOUSTIC ENCLOSURE

L x W x H in (mm)	94.8 (2408.9) x 38 (965.1) x 62 (1573.9)
Weight lbs (kg)	Steel: 2871 (1302) Aluminum: 2517 (1142)

YOUR FACTORY RECOGNIZED GENERAC INDUSTRIAL DEALER

Specification characteristics may change without notice. Please consult a Generac Power Systems Industrial Dealer for detailed installation drawings.

LEVEL 2 ACOUSTIC ENCLOSURE SG35 5.4L

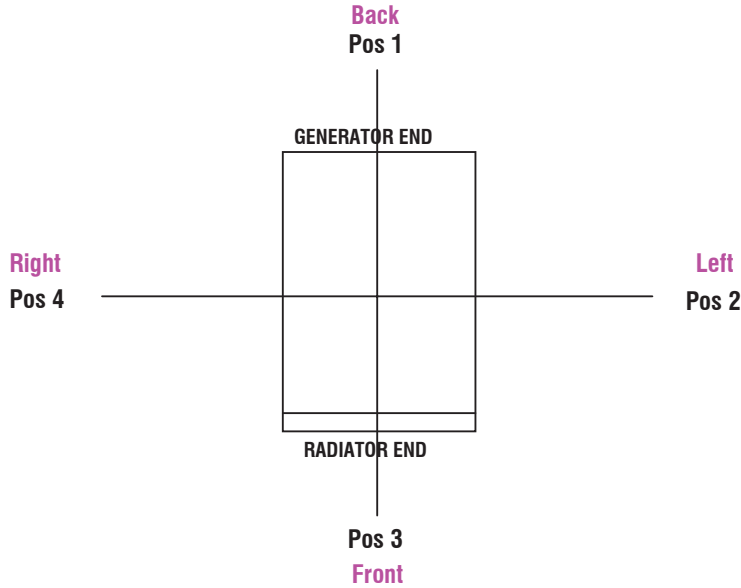

Measured Sound Levels - 60 Hz

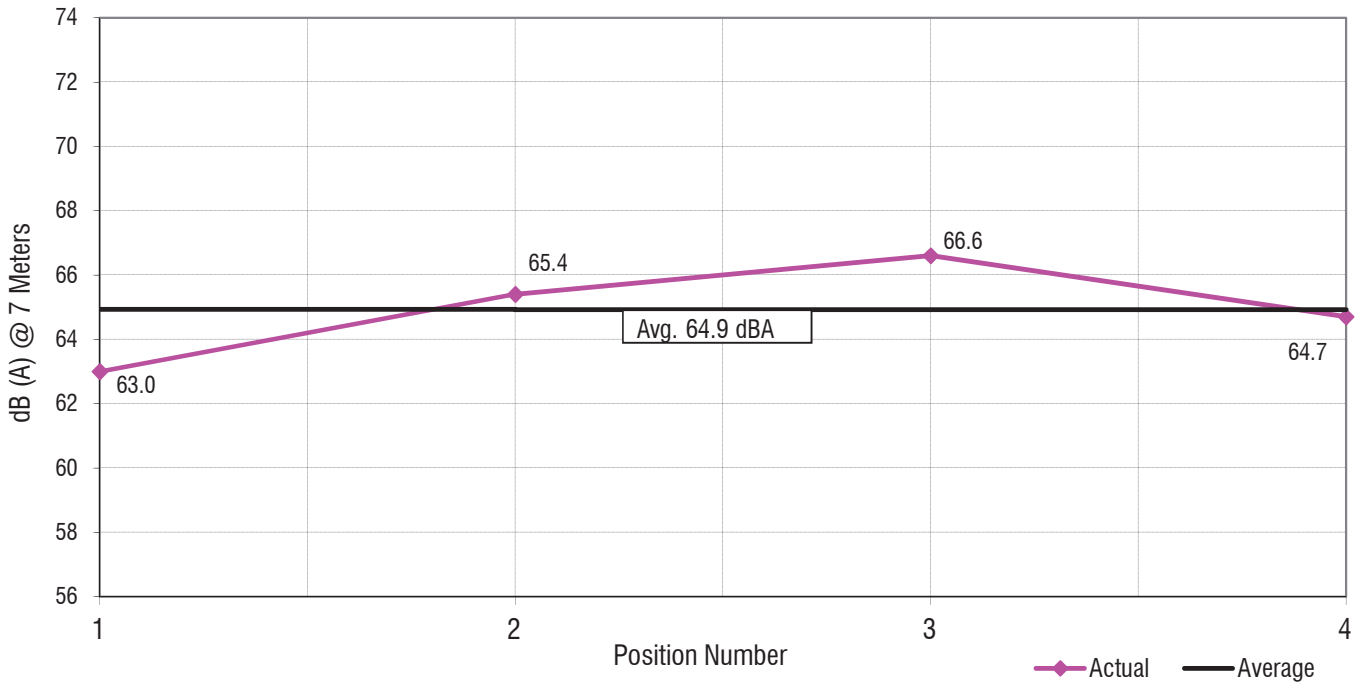

Notes:

1. All positions 23 ft (7M) from side faces of generator set.
2. Generator operating at full load.
3. Test conducted on a 100 foot diameter asphalt surface.
4. Non-enclosed sets do not include exhaust sound during testing.

**EXHAUST EMISSIONS
DATA**

**STATEMENT OF EXHAUST EMISSIONS
2016 SPARK-IGNITED GENERATORS
INDUSTRIAL SERIES**

NON-SCAQMD												
Model	Engine	EPA Engine Family	Fuel	CATALYST Req'd	Comb Cat or Separate Cat	EPA Cert #	Grams/bhp-hr.			Rated RPM	BHP	Fuel Flow (lb/hr)
							THC	NOx	CO			
SG035	5.4	GGNXB05.42NN	NG	No	NR	GGNXB05.42NN-049	1.60	2.52	95.32	1800	82.10	36.91
SG035	5.4	GGNXB05.42NL	LPG	No	NR	GGNXB05.42NL-048	1.24	3.45	112.01	1800	82.30	34.60
SG050	5.4	GGNXB05.42NN	NG	No	NR	GGNXB05.42NN-049	1.60	2.52	95.32	1800	82.10	36.91
SG050	5.4	GGNXB05.42NL	LPG	No	NR	GGNXB05.42NL-048	1.24	3.45	112.01	1800	82.30	34.60
SG050	6.8	GGNXB06.82NL	LPG	No	NR	GGNXB06.82NL-010	1.86	2.67	172.30	1800	84.66	46.55

NR: Not Required

Refer to page 2 for definitions and advisory notes.

CALIFORNIA SCAQMD CERTIFIED												
Model	Engine	EPA Engine Family	Fuel	CATALYST Req'd	SCAQMD CEP #	EPA Cert #	Grams/bhp-hr.			Rated RPM	BHP	Fuel Flow (lb/hr)
							THC	NOx	CO			
SG035	5.4	GGNXB05.42L1	NG	Yes	530212	GGNXB05.42L1-017	0.38	0.22	0.64	1800	81.95	24.91
SG035	5.4	GGNXB05.42L2	LPG	Yes	530215	GGNXB05.42L2-018	0.04	0.10	0.70	1800	81.70	29.13
SG050	5.4	GGNXB05.42L1	NG	Yes	530212	GGNXB05.42L1-017	0.38	0.22	0.64	1800	81.95	24.91
SG050	5.4	GGNXB05.42L2	LPG	Yes	530215	GGNXB05.42L2-018	0.04	0.10	0.70	1800	81.70	29.13
SG050	6.8	GGNXB06.82L6	LPG	Yes	470347	GGNXB06.82L6-024	0.01	0.05	0.50	1800	85.92	34.14

Refer to page 2 for definitions and advisory notes.

EXHAUST EMISSIONS DATA

STATEMENT OF EXHAUST EMISSIONS 2016 SPARK-IGNITED GENERATORS

2016 EPA SPARK-IGNITED EXHAUST EMISSIONS DATA

Effective since 2009, the EPA has implemented exhaust emissions regulations on stationary spark-ignited (gaseous) engine generators for emergency applications. All Generac spark-ignited gensets, including SG, MG, QTA and QT series gensets, that are built with engines manufactured in 2009 and later meet the requirements of 40CFR part 60 subpart JJJJ and are EPA certified. These generator sets are labeled as EPA Certified with decals affixed to the engines' valve covers.

The attached documents summarize the general information relevant to EPA certification on these generator sets. This information can be used for submittal data and for permitting purposes, if required. These documents include the following information:

EPA Engine Family

The EPA Engine Family is assigned by the Manufacturer under EPA guidelines for certification purposes and appears on the EPA certificate.

Catalyst Required

Indicates whether an exhaust catalyst and Air/Fuel Ratio control system are required on the generator set to meet EPA certification requirements. Generally, units rated 80kW and smaller do not require a catalyst to meet EPA certification requirements. Please note that some units that do not require a catalyst to meet EPA requirements do need a catalyst if the California SCAQMD option is selected. Please see "California SCAQMD" below for additional information on this option.

Combination Catalyst or Separate Catalyst

SG and MG series generator sets typically utilize a single combination catalyst/silencer as part of meeting EPA certification requirements. Many QT and QTA series generator sets use the same engines as SG and MG series units, but have different exhaust configurations that require the use of conventional silencers with additional separate catalysts installed.

EPA Certificate Number

Upon certification by the EPA, a Certificate Number is assigned by the EPA.

Emissions Actuals - Grams/bhp-hr

Actual exhaust emission data for Total Hydrocarbons (THC), Nitrogen Oxides (NOx) and Carbon Monoxide (CO) that were submitted to EPA and are official data of record for certification. This data can be used for permitting if necessary. Values are expressed in grams per brake horsepower-hour; to convert to grams/kW-hr, multiply by 1.341. Please see advisory notes below for further information.

California Units, SCAQMD CEP Number

A separate low-emissions option is available on many Generac gaseous-fueled generator sets to comply with the more stringent South Coast Air Quality Management District requirements that are recognized in certain areas in California. Gensets that include this option are also EPA Certified.

General Advisory Note to Dealers

The information provided here is proprietary to Generac and its' authorized dealers. This information may only be disseminated upon request, to regulatory governmental bodies for emissions permitting purposes or to specifying organizations as submittal data when expressly required by project specifications, and shall remain confidential and not open to public viewing. This information is not intended for compilation or sales purposes and may not be used as such, nor may it be reproduced without the expressed written permission of Generac Power Systems, Inc.

Advisory Notes on Emissions Actuals

- The stated values are actual exhaust emission test measurements obtained from units representative of the generator types and engines described.
- Values are official data of record as submitted to the EPA and SCAQMD for certification purposes. Testing was conducted in accordance with prevailing EPA protocols, which are typically accepted by SCAQMD and other regional authorities.
- No emission values provided are to be construed as guarantees of emissions levels for any given Generac generator unit.
- Generac Power Systems reserves the right to revise this information without prior notice.
- Consult state and local regulatory agencies for specific permitting requirements.
- The emissions performance data supplied by the equipment manufacturer is only one element required toward completion of the permitting and installation process. State and local regulations may vary on a case-by-case basis and must be consulted by the permit applicant/equipment owner prior to equipment purchase or installation. The data supplied herein by Generac Power Systems cannot be construed as a guarantee of installability of the generator set.
- The emission values provided are the result of multi-mode, weighted scale testing in accordance with EPA testing regulations, and may not be representative of any specific load point.
- The emission values provided are not to be construed as emission limits.



**UNITED STATES ENVIRONMENTAL PROTECTION AGENCY
2016 MODEL YEAR
CERTIFICATE OF CONFORMITY
WITH THE CLEAN AIR ACT**

**OFFICE OF TRANSPORTATION
AND AIR QUALITY
ANN ARBOR, MICHIGAN 48105**

Certificate Issued To: Generac Power Systems, Inc.
(U.S. Manufacturer or Importer)

Certificate Number: GGNXB05.42NL-048

Effective Date:
10/20/2015

Expiration Date:
12/31/2016

Mary J. Manners

Byron J. Bunker, Division Director
Compliance Division

Issue Date:
10/20/2015

Revision Date:
N/A

Manufacturer: Generac Power Systems, Inc.
Engine Family: GGNXB05.42NL
Mobile/Stationary Certification Type: Stationary
Fuel : LPG/Propane
Emission Standards :
Part 90 Phase I
CO (g/kW-hr) : 519
HC + NOx (g/kW-hr) : 13.4
Emergency Use Only : Y

Pursuant to Section 213 of the Clean Air Act (42 U.S.C. section 7547) and 40 CFR Part 60, 1065, 1068, and 60 (stationary only and combined stationary and mobile) and subject to the terms and conditions prescribed in those provisions, this certificate of conformity is hereby issued with respect to the test engines which have been found to conform to applicable requirements and which represent the following nonroad engines, by engine family, more fully described in the documentation required by 40 CFR Part 60 and produced in the stated model year.

This certificate of conformity covers only those new nonroad spark-ignition engines which conform in all material respects to the design specifications that applied to those engines described in the documentation required by 40 CFR Part 60 and which are produced during the model year stated on this certificate of the said manufacturer, as defined in 40 CFR Part 60. This certificate of conformity does not cover nonroad engines imported prior to the effective date of the certificate.

It is a term of this certificate that the manufacturer shall consent to all inspections described in 40 CFR 1068.20 and authorized in a warrant or court order. Failure to comply with the requirements of such a warrant or court order may lead to revocation or suspension of this certificate for reasons specified in 40 CFR Part 60. It is also a term of this certificate that this certificate may be revoked or suspended or rendered void *ab initio* for other reasons specified in 40 CFR Part 60.

This certificate does not cover large nonroad engines sold, offered for sale, or introduced, or delivered for introduction, into commerce in the U.S. prior to the effective date of the certificate.



5/23/2017

NCIC File No.: ELD-17-37

Jared Kearsley
Epic Wireless Group
8700 Auburn Folsom Road, Suite 400
Granite Bay, CA 95746

Records Search Results for
AT&T/Epic Wireless/El Dorado County Resource Record Search Request – APN: 078-180-38

Jared Kearsley:

Per your request received by our office on 5/5/2017, a complete records search was conducted by searching California Historic Resources Information System (CHRIS) maps for cultural resource site records and survey reports in El Dorado County within a 1/4-mile radius of the proposed project area.

Review of this information indicates that the proposed project area contains zero (0) prehistoric-period resource(s) and zero (0) historic-period cultural resource(s). Additionally, zero (0) cultural resources study reports on file at this office cover a portion of the proposed project area.

Outside the proposed project area, but within the 1/4-mile radius, the broader search area contains zero (0) prehistoric-period resource(s) and one (1) historic-period cultural resource(s): P-9-235. Additionally, four (4) cultural resources study reports on file at this office cover a portion of the broader search area: 1007, 917, 3501, and 6965.

In this part of El Dorado County, archaeologists locate prehistoric-period habitation sites “along streams or on ridges or knolls, especially those with southern exposure.” (Moratto 1984:290) This region is known as the ethnographic-period territory of the Nisenan, also called the Southern Maidu. The Nisenan maintained permanent settlements along major rivers in the Sacramento Valley and foothills; they also periodically traveled to higher elevations (Wilson and Towne 1978:387-389). The proposed project search area is situated in the Sierra Nevada about a quarter mile northwest of Clear Creek. Given the extent of known cultural resources and the environmental setting, there is moderate potential for locating prehistoric-period cultural resources in the immediate vicinity of the proposed project area.

Within the search area, the 1870 GLO plat of T10N, R12E shows evidence of nineteenth-century houses called “McLure’s House” and “Buffington’s House.” The 1952 Camino 7.5’ USGS topographical map shows evidence of twentieth-century paved and unpaved roads and buildings associated with the village of Pleasant Valley. Given the extent of known cultural resources and patterns of local history, there is moderate potential for locating historic-period cultural resources in the immediate vicinity of the proposed project area.

SENSITIVITY STATEMENT:

- 1) With respect to cultural resources, it appears that the proposed project area **is sensitive**.
- 2) Should the lead agency/authority require a cultural resources survey, a list of qualified local consultants can be found at <http://chrisinfo.org>.
- 3) If cultural resources are encountered during the project, avoid altering the materials and their context until a qualified cultural resources professional has evaluated the project area. **Project personnel should not collect cultural resources**. Prehistoric-period resources include: chert or obsidian flakes, projectile points, and other flaked-stone artifacts; mortars, grinding slicks, pestles, and other groundstone tools; and dark friable soil containing shell and bone dietary debris, heat-affected rock, or human burials. Historic-period resources include: stone or adobe foundations or walls; structures and remains with square nails; mine shafts, tailings, or ditches/flumes; and refuse deposits or bottle dumps, often located in old wells or privies.
- 4) Identified cultural resources should be recorded on DPR 523 (A-J) historic resource recordation forms, available at http://ohp.parks.ca.gov/?page_id=1069.
- 5) Review for possible historic-period cultural resources has included only those sources listed in the referenced literature and should not be considered comprehensive. The Office of Historic Preservation has determined that buildings, structures, and objects 45 years or older may be of historical value. If the area of potential effect contains such properties not noted in our research, they should be assessed by an architectural historian before commencement of project activities.

Due to processing delays and other factors, not all of the historical resource reports and resource records that have been submitted to the Office of Historic Preservation are available via this records search. Additional information may be available through the federal, state, and local agencies that produced or paid for historical resource management work in the search area. Additionally, Native American tribes have historical resource information not in the California Historical Resources Information System (CHRIS) Inventory, and you should contact the California Native American Heritage Commission for information on local/regional tribal contacts.

The California Office of Historic Preservation (OHP) contracts with the California Historical Resources Information System's (CHRIS) regional Information Centers (ICs) to maintain information in the CHRIS inventory and make it available to local, state, and federal agencies, cultural resource professionals, Native American tribes, researchers, and the public. Recommendations made by IC coordinators or their staff regarding the interpretation and application of this information are advisory only. Such recommendations do not necessarily represent the evaluation or opinion of the State Historic Preservation Officer in carrying out the OHP's regulatory authority under federal and state law.

Thank you for using our services. Please contact North Central Information Center at (916) 278-6217 if you have any questions about this record search. An invoice is enclosed.

Sincerely,

Dr. Nathan Hallam, Coordinator
North Central Information Center



SYCAMORE ENVIRONMENTAL CONSULTANTS, INC.

6355 Riverside Blvd., Suite C, Sacramento, CA 95831
916/ 427-0703 Fax 916/ 427-2175
www.sycamoreenv.com

21 July 2017

Mr. Jared Kearsley
Leasing / Zoning Manager
Epic Wireless Group
8700 Auburn Folsom Road, Suite 400
Granite Bay, CA 95746
Phone: 916-755-1326

Subject: *AT&T Pleasant Valley Site CVL03180 Project in El Dorado County, CA*

Dear Mr. Kearsley:

Sycamore Environmental prepared a Biological Resources Evaluation (BRE) for the AT&T Pleasant Valley Site CVL03180 Project in El Dorado County, CA. The BRE is a baseline document. This letter identifies potential biological resource issues and recommended avoidance and minimization measures.

Migratory Birds and Birds of Prey

Under the MBTA, nests that contain eggs or unfledged young are not to be disturbed during the breeding season. Nesting or attempted nesting by migratory birds and birds-of-prey is anticipated from 15 January through 31 August.

Recommendation:

- Tree and vegetation removal shall occur outside of the nesting season (15 January through 31 August annually). All tree removal shall occur between 1 September and 14 January, which is outside of nesting season for MBTA and Fish and Game Code protected birds. If work occurs outside the nesting season, there will be no need to conduct a preconstruction survey for active nests.
- If project work occurs during the nesting season, a qualified biologist shall conduct a pre-construction survey for nesting birds of prey and other birds protected by the MBTA and Fish and Game Code within 15 days prior to the start of construction. The survey area shall cover the Project, a 500 ft radius for nesting birds of prey, and a 100 ft radius for all other MBTA and Fish and Game Code protected birds. If no active nest of a bird of prey, MBTA bird, or other Fish and Game Code-protected bird is found, then no further mitigation measures are necessary.
- Should an active nest of a protected bird be identified, an exclusion zone of 500 feet shall be established around the nest if it is a bird of prey, and 100 feet if it is a protected bird other than a bird of prey. Buffer sizes may be adjusted at the discretion of the biologist depending on the species of bird, the location of the nest relative to the project, the existing level of disturbance, and other site-specific conditions. No work will be allowed in the exclusion zone until the biologist determines that the nest is no longer active, or monitoring determines that a smaller ESA will protect the active nest.
- From 15 January through 31 August, if additional trees or shrubs need to be trimmed and/or removed after construction has started, a survey will be conducted for active nests in the area to be affected. If an active nest is found, the above measures will be implemented.

- If an active nest is identified in or adjacent to the construction zone after construction has started, the above measures will be implemented to ensure construction is not causing disturbance to the nest.

Please contact me with any questions.

Sincerely,

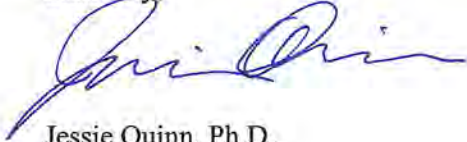

Jessie Quinn, Ph.D.
Ecologist

Enclosure: Biological Resources Evaluation

Biological Resources Evaluation
for the
AT&T Pleasant Valley Site CVL03180 Project
El Dorado County, CA

Prepared by:

Sycamore Environmental Consultants, Inc.

6355 Riverside Blvd., Suite C

Sacramento, CA 95831

Phone: 916/ 427-0703

Contact: Jessie Quinn

Prepared for:

Epic Wireless Group, LLC

8700 Auburn Folsom Road, Suite 400

Granite Bay, CA 95746

Phone: 916/ 755-1326

Contact: Jared Kearsley

July 2017

[This page intentionally left blank]



Biological Resources Evaluation
for the
AT&T Pleasant Valley Site CVL03180
El Dorado County, CA

TABLE OF CONTENTS

I. SUMMARY OF FINDINGS AND CONCLUSIONS 1

II. INTRODUCTION..... 1

A. Purpose of Report 1

B. Project Location 1

C. Project Applicant 1

D. Project Description..... 2

III. STUDY METHODS..... 7

A. Studies Conducted 7

B. Survey Dates, Personnel, and Coverage 7

C. Problems Encountered and Limitations That May Influence Results..... 7

D. Literature Search 7

E. Field Survey Methods 8

F. Mapping 8

IV. ENVIRONMENTAL SETTING 9

A. Soils..... 9

B. Weather and Climate Conditions 9

C. Biological Communities 13

 1. Gravel Road..... 17

 2. Ruderal 17

D. The Existing Level of Disturbance 17

V. BIOLOGICAL RESOURCES IN THE BIOLOGICAL STUDY AREA 18

A. Determination of Special-Status Species and Communities in the Biological Study Area 18

B. Evaluation of Special-Status Natural Communities..... 18

C. Evaluation of Special-Status Fish and Wildlife Species 18

 1. Birds 18

D. Evaluation of Special-Status Plant Species..... 18

E. Potentially Jurisdictional Waters 19

VI. LITERATURE CITED & PERSONAL COMMUNICATIONS..... 20

A. Literature Cited 20

VII. PREPARERS..... 21

FIGURES

Figure 1. Project Location.....	3
Figure 2. Aerial Photograph.....	5
Figure 3. Soils Map.....	11
Figure 4. Biological Resources Map.....	15

TABLES

Table 1. USGS Quads Evaluated for the AT&T Pleasant Valley Site Plan Project . Error! Bookmark not defined.	
Table 2. Biological Communities and Other Features in the BSA	13

APPENDICES

Appendix A. Plant and Wildlife Species Observed	
Appendix B. USFWS Species List	
Appendix C. CNDDDB Summary Report and CNPS Inventory Query	
Appendix D. Photographs	

I. SUMMARY OF FINDINGS AND CONCLUSIONS

This Biological Resources Evaluation report was prepared for the AT&T Pleasant Valley Site CVL03180 Project (Project) to document baseline biological conditions observed in 2017. The approximately 0.15 acre (ac) Biological Study Area (BSA) is located north of Pleasant Valley road in the community of Pleasant Valley in unincorporated El Dorado County, CA.

Trees and vegetation in and adjacent to the BSA provide habitat for nesting birds protected by the Migratory Bird Treaty Act (MBTA) and Fish and Game Code. The nesting bird season is generally defined as 15 February through 31 August, though some species of birds may begin nesting as early as 15 January.

No special-status wildlife or plant species have the potential to occur in the BSA. The BSA is not within an Important Biological Corridor or Important Habitat for Migratory Deer Herds. The 0.15-acre parcel on which the BSA is located does not contain oak woodlands or oak trees. There are no wetlands or waters in the BSA.

II. INTRODUCTION

A. Purpose of Report

The purpose of this Biological Resources Evaluation (BRE) report is to document baseline biological resources in the AT&T Pleasant Valley Site CVL03180 Project (Project) Biological Study Area (BSA).

B. Project Location

The approximately 0.15 ac BSA is located in the western foothills of the Sierra Nevada Mountains in unincorporated El Dorado County, California. The BSA is located in a rural residential area and bound by large lot residences on all sides. The BSA is on the Camino USGS topographic quad (T10N R12E, Section 28, Mt. Diablo Base & Meridian; Figure 1) and is in the South Fork American Hydrologic Unit (Hydrologic Unit Code 18020129). The geographic coordinates of the BSA are 38.684232° north, 120.662032° west (WGS84), and the UTM coordinates (Zone 10N) are 703,356 meters east, 4,284,323 meters north. Elevation in the BSA ranges from approximately 2,537 to 2,540 ft above sea level. The BSA is located in a flat valley below some gentle hills. Figure 2 is a July 2016 aerial photo of the BSA and surrounding area.

C. Project Applicant

Applicant:
AT&T Mobility
2600 Camino Ramon
San Ramon, CA 94583

Consulting Planner
Epic Wireless Group, LLC
8700 Auburn Folsom Road, Suite 400
Granite Bay, CA 95746
Phone: 916/ 755-1326
Contact: Mr. Jared Kearsley

D. Project Description

AT&T intends to construct a wireless telecommunications facility at 4559 Strauss Drive, Placerville, in south central El Dorado County. The proposed AT&T Pleasant Valley Site CVL03180 Project (Project) facility tower will be a new 153-ft monopole tower with a new GPS antenna, six wireless antennas, six remote radio units (RRUs), and one surge suppressor mounted at 150 ft; six wireless antennas and 12 RRUs mounted at 140 ft; and nine RRUs and three surge protectors on a collar mount directly below the upper antennas. In the future, the tower can also accommodate two 4-ft diameter microwave dishes mounted at 132.5 ft. Future antennas can be mounted by other carriers at approximately 125 and 110 ft. The tower has been designed with pine foliage to match the existing surrounding trees. The foliage would extend horizontally approximately 7 ft above the top of the structure to an overall structure height of approximately 160 ft. Antennas will be concealed with socks. The monopole “trunk” and RRUs will be painted brown.

The facility will include graveled road and access improvements, a new 35 Kw propane generator with a 500-gallon propane tank, and a pre-fabricated equipment shelter and associated interior equipment. The facility will be located on a 40-ft by 45-ft lease area enclosed with a new 6-ft chain link fence and 12-ft wide double access gate. Connecting the facility with existing power and fiber lines will require excavation of an approximately 88-ft long linear utility trench through which to run cables. The new power and fiber lines will be connected to an existing utility pole approximately 90 ft south of the proposed facility. A new splice box, located along the new utility lines, will be installed less than 10 ft from the proposed facility. Gravel bags with fiber rolls or silt barriers will be placed around drain inlets in the vicinity of the project, including the point of site access.

The Project does not include tree removal or pruning.

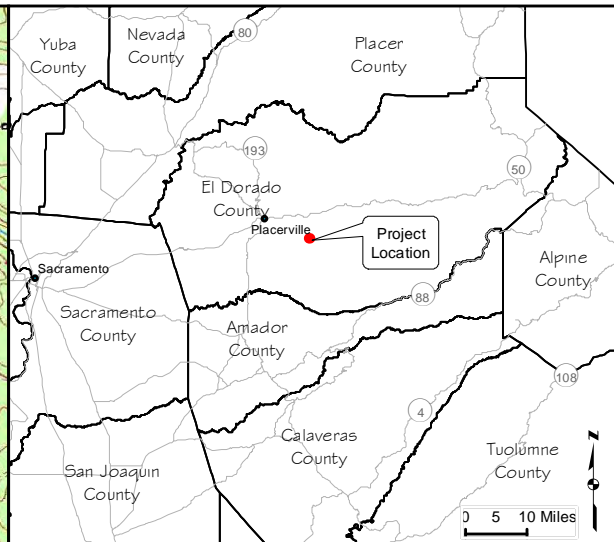

AT&T Pleasant Valley Site
 CVLO3180 Project
 El Dorado County, CA
 18 July 2017

Figure 1. Project Location Map

 Project Location

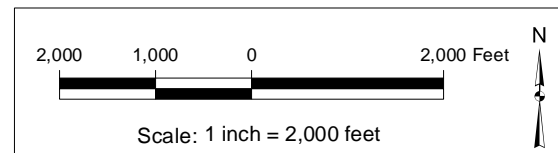

SYCAMORE
 Environmental
 Consultants, Inc.

Camino, CA (Revised 1973)
 CASIL California USGS Digital Raster Graphics (DRG),
 7.5 Minute (C) Series, Albers Nad83 Mosaics (MrSID)
 o_nw0102.sid

[This page intentionally left blank]



AT&T Pleasant Valley Site
 CVL03 I80 Project
 El Dorado County, CA
 18 July 2017

 Biological Study Area (BSA)

 **SYCAMORE**
 Environmental
 Consultants, Inc.

Aerial Photograph: 11 July 2016
 NAIP2016 USDA FSA Imagery
 ESRI ArcGIS Basemap Layer

Figure 2. Aerial Photograph

[This page intentionally left blank]

III. STUDY METHODS

A. Studies Conducted

An evaluation of biological resources was conducted to determine whether any special-status plant or wildlife species, their habitat, or sensitive habitats occur in the BSA. Data on known special-status species and habitats in the area was obtained from state and federal agencies. Maps and aerial photographs of the BSA and surrounding area were reviewed. The field survey, map review, and a review of the biology of evaluated species and habitats were used to determine the special-status species and sensitive habitats that could occur in the BSA.

Special-status species in this report are those listed under the federal or state endangered species acts, under the California Native Plant Protection Act, as a California species of special concern or fully protected by the California Department of Fish and Wildlife (CDFW), or that are California Rare Plant Rank 1 or 2 (CNPS 2017). This is consistent with special-status species definitions in the El Dorado County General Plan EIR (2004). Special-status natural communities are waters, wetlands, riparian communities, and any natural community ranked S1, S2, or S3 by CDFW (2010). Special-status species and communities may also include those considered locally important or sensitive. El Dorado County identifies Important Biological Corridors and Important Habitat for Migratory Deer Herds in its General Plan (2016), and Rare Plan Mitigation areas per the Board of Supervisors Resolution No. 205-98. General Plan Policy 7.4.4.4 requires all new development projects adhere to tree canopy retention and replacement standards.

Data received from USFWS, CNDDDB, and CNPS records (Appendices B and C) were used to evaluate species and habitats of concern with potential to occur within the BSA. The CNDDDB tracks other species that have not been designated by CDFW as a California species of special concern; these species were not evaluated as special-status species in this BRE.

B. Survey Dates, Personnel, and Coverage

Fieldwork for this BRE, covering the 0.15-ac BSA, was conducted by Juan Mejia, Biologist, and Adrienne Levoy, Biologist, on 13 July 2017.

C. Problems Encountered and Limitations That May Influence Results

No problems or limitations were encountered.

D. Literature Search

An IPaC Trust Resource Report was obtained from the U.S. Fish and Wildlife Service (USFWS), Sacramento Field Office on 6 July 2017. (Appendix B). The list identifies federal-listed, candidate, and proposed species that potentially occur in, or could be affected by, the Project.

The California Natural Diversity Database (CNDDDB) was queried prior to field surveys for known occurrences of special-status species in or near the BSA (Coloma Quad and the eight surrounding quads). The list was updated most recently on 6 July 2017 (CDFW 2017, Appendix C). Table 1 lists the USGS quads evaluated.

Table 1. USGS Quads Evaluated for the AT&T Pleasant Valley CVL03180 Plan Project

Garden Valley	Slate Mountain	Pollock Pines
Placerville	Camino	Sly Park
Fiddletown	Aukum	Omo Ranch

The California Native Plant Society (CNPS) inventory of rare and endangered plants was queried prior to field surveys for known occurrences of special-status plants in or near the BSA (Camino Quad and the eight surrounding quads). The list was updated most recently on 10 July 2017 (Appendix C).

E. Field Survey Methods

Biological surveys conducted for this report consisted of biologists walking through the BSA while looking for special-status wildlife species, their sign, and their habitat. Areas adjacent to the BSA were also inspected for important habitat features such as elderberry shrubs, vernal pools, burrows, and other wetlands/waters. Biological community boundaries were recorded with a sub-meter accurate GPS. All wildlife species observed in or near the BSA were recorded (Appendix A).

F. Mapping

Biological communities observed by Sycamore Environmental were mapped using a Trimble GeoXT sub-meter accurate GPS. The July 2016 aerial photo in Figures 2 and 4 was downloaded from ESRI World Imagery. Biological communities were mapped based on GPS data, field observations, and interpretation of the aerial photographs available on Google Earth.

IV. ENVIRONMENTAL SETTING

The BSA is located in an area of residential properties, approximately 350 ft north of the intersection of Mt Aukum Road and Pleasant Valley Road in Pleasant Valley, CA. Land use adjacent to the BSA consists of dispersed residences with some patches of oaks. Clear Creek is located 760 feet south of the BSA. The parcel on which the BSA is located is approximately 2.08 acres in size.

A. Soils

Mapped soil units in the BSA were determined using the Soil Survey of El Dorado Area (NRCS 1974). Mapped soil units in the BSA is Josephine silt loam, 5 to 15% slopes (Figure 3; NRCS 2016). Figure 3 is a soils map.

Josephine silt loam, 5 to 15% Percent Slopes:

These soils occur on broad ridgetops, toeslopes, footslopes, and side slopes of mountains with douglas fir, ponderosa pine, and Pacific madrone. A typical profile of Boomer loam is dark brown (7.5YR 3/2) gravelly loam from 0 to 3 inches; brown (7.5YR 4/4) gravelly loam from 3 to 9 inches; reddish brown (5YR 5/4) clay loam from 9 to 16 inches; yellowish red (5YR 5/6) clay loam from 16 to 32 inches; yellowish red (5YR 4/6) clay loam from 32 to 42 inches; yellowish red (5 YR 4/6) gravelly clay loam from 42 to 51 inches; yellowish red (5YR 5/6) gravelly clay loam 51 to 59 inches; and saprolitic siltstone below 59 inches. This soil is neutral to medium acidic. Josephine series are fine-loamy, mixed, superactive mesic Typic Haploxerults. These soils formed in moderately fine textured colluvium and residuum weathered from sedimentary, metamorphosed sedimentary, and volcanic rocks. Permeability is moderately slow.

B. Weather and Climate Conditions



Fieldwork was conducted on 13 July 2017. Precipitation in California is typically reported for the period from 1 July through 30 June of the next calendar year. The historic average precipitation from 1 July through 12 July for the National Weather Service Placerville gauge is 38.24 inches (CDEC 2017). From 1 July 2016 through 25 April 2017, the Placerville Gauge received 72.45 inches of rain, or 190% of the average precipitation. The BSA had wetter than average hydrologic conditions during the 13 July fieldwork. Weather during the survey was sunny, calm, and dry.

[This page intentionally left blank]



AT&T Pleasant Valley Site
 CVLO3180 Project
 El Dorado County, CA
 18 July 2017

Figure 3. Soils Map

-  Biological Study Area (BSA)
-  Soil Boundary

Soil Mapping Unit
Symbol Name

JtC Josephine silt loam,
 5 to 15 percent slopes

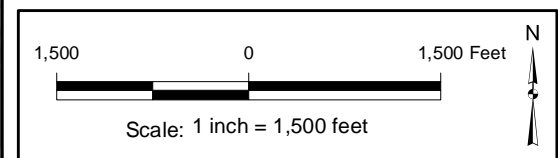

SYCAMORE
 Environmental
 Consultants, Inc.

Soil Survey Geographic (SSURGO) database for
 El Dorado Area, California, USDA, NRCS
 URL: <http://SoilDataMart.nrcs.usda.gov/>

Aerial Photograph: 11 July 2016
 NAIP2016 USDA FSA Imagery
 ESRI ArcGIS Basemap Layer

[This page intentionally left blank]

C. Biological Communities

Biological communities are defined by species composition and relative abundance. Biological communities correlate where applicable with the list of California terrestrial natural communities recognized by CDFW (2010). Descriptions of biological communities present in the BSA are included below. Biological community descriptions include plant species identified during the field surveys. Biological communities are mapped in Figure 4 and their acreages are in Table 2. Photographs of the BSA are in Appendix D.

Table 2. Biological Communities in the BSA

Biological Community	Vegetation Alliances and CDFW Alliance Codes ¹	Rarity Rank ²	Acreage ³
Ruderal	--	--	0.13
Gravel Road	--	--	0.02
Total:			0.15

¹ Vegetation alliances based on descriptions and classification methods in Sawyer et al. (2009). Alliance codes from CDFW (2010). Some communities may lack recognized vegetation alliances or contain multiple alliances.



² Rarity ranking follows NatureServe's Heritage Methodology and is based on degree of imperilment as measured by rarity, trends, and threats. State (S) ranks of 1-3 are considered highly imperiled by CDFW (2010). Nonnative vegetation has no rarity rank.

³ Acreages were calculated using ArcMap functions.

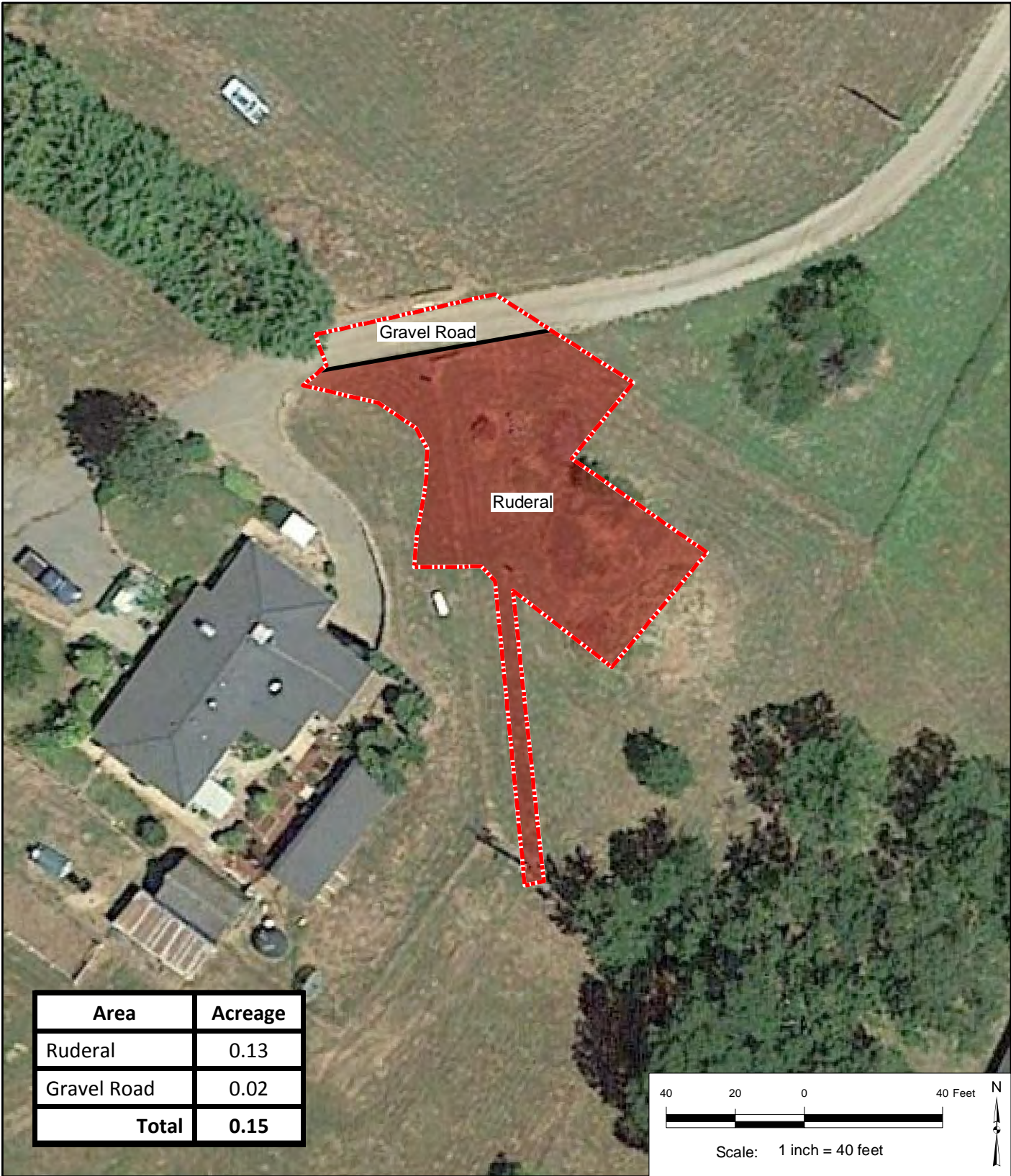
[This page intentionally left blank]



AT&T Pleasant Valley Site
 CVL03 180 Project
 El Dorado County, CA
 18 July 2017

-  Biological Study Area (BSA)
-  Gravel road
-  Ruderal



Aerial Photograph:
 31 May 2016
 Google Earth Imagery

Figure 4.
 Biological Resources Map

[This page intentionally left blank]

1. Gravel Road

A total of 0.02 acre of developed land use occurs in the BSA, consisting of a gravel road.

2. Ruderal

A total of 0.13 acre of ruderal land occurs in the south end of the BSA. This community is dominated by kickxia (*Kickxia elatine*), slender woolly-marbles (*Psilocarphus tenellus*), and yellow star-thistle (*Centaurea solstitialis*). The vegetation is interspersed with bare ground. Multiple gopher mounds were observed in this area. Ruderal land has no special status.

D. The Existing Level of Disturbance

The vast majority of the BSA has a high level of existing disturbance from the gravel roads, mowing of the grass, and human access.

V. BIOLOGICAL RESOURCES IN THE BIOLOGICAL STUDY AREA

A. Determination of Special-Status Species and Communities in the Biological Study Area

Field surveys were conducted by Sycamore Environmental biologists to determine if individuals or habitat for special-status species identified in the file data were present in the BSA. Special-status species for which suitable habitat is present are discussed below.

Special-status wildlife species, plant species, and communities for which suitable habitat is not present, or whose distributional limits preclude the possibility of their occurrence in the BSA, are not discussed in Section V of this report.

B. Evaluation of Special-Status Natural Communities

The BSA is not located within an Important Biological Corridor (IBC). There are no special-status natural communities within the BSA.

The BSA is not located within Important Habitat for Migratory Deer Herds.

There are no oak woodlands or oak trees on the 0.15-acre parcel on which the BSA is located.

C. Evaluation of Special-Status Fish and Wildlife Species

1. Birds

Migratory Birds and Birds of Prey

STATUS: Fish and Game Code 3503.5 protects all birds in the orders Falconiformes and Strigiformes (collectively known as birds of prey). Birds of prey include raptors, falcons, and owls. Migratory birds are protected under the federal Migratory Bird Treaty Act (MBTA) of 1918 (16 U.S.C. 703-711). The MBTA makes it unlawful to take, possess, buy, sell, purchase, or barter any migratory bird listed in 50 CFR Part 10 including feathers or other parts, nests, eggs, or products, except as allowed by implementing regulations (50 CFR 21). All migratory bird species are protected by the MBTA. Any disturbance that causes direct injury, death, nest abandonment, or forced fledging of migratory birds, is restricted under the MBTA. Any removal of active nests during the breeding season or any disturbance that results in the abandonment of nestlings is considered a 'take' of the species under federal law.

HABITAT PRESENT IN THE BSA: No bird of prey nests or nests of other birds protected by the MBTA or Fish and Game Code were observed in the BSA during biological surveys. Bird species observed are listed in Appendix A. Trees and vegetation in the BSA provide nesting habitat for birds of prey and other birds protected by the MBTA and Fish and Game Code.

DISCUSSION: The nesting bird season is generally defined as February 15th through August 31st, though some species can begin nesting as nearly as January 15th.

D. Evaluation of Special-Status Plant Species

The project located in Rare Plant Mitigation Area 2. There are no special status plant species with potential to occur in the BSA.

E. Potentially Jurisdictional Waters

Field surveys conducted by Sycamore Environmental biologists included evaluation of potential wetlands or waters within the BSA.

There are no potentially jurisdictional waters in the BSA.

VI. LITERATURE CITED & PERSONAL COMMUNICATIONS

A. Literature Cited

- Baldwin, B. et al. (ed.). 2012. The Jepson Manual, Vascular Plants of California, 2nd ed. University of California Press, Berkeley, CA.
- California Data Exchange Center (CDEC). Accessed July 2017. Real-Time data, Placerville Gauge. California Department of Water Resources, Sacramento, CA. http://cdec.water.ca.gov/cgi-progs/staMeta?station_id=PCV
- California Department of Fish and Wildlife (CDFW). 10 September 2010. List of California Vegetation Alliances. Biogeographic Data Branch, CNDDDB, Sacramento, CA.
- California Department of Fish and Wildlife (CDFW). April 2017 (2017). Special Plant and Animal Lists, including the following: Special Vascular Plants, Bryophytes, and Lichens List, Endangered, Threatened and Rare Plants List, Special Animals List and Endangered and Threatened Animals List. Nongame Wildlife, Sacramento, CA. <http://www.dfg.ca.gov/wildlife/nongame/list.html>
- California Native Plant Society (CNPS). Accessed May and June 2017. Inventory of rare and endangered plants (online edition, v8-01a). California Native Plant Society, Sacramento, CA. <http://www.rareplants.cnps.org/>
- El Dorado County. January 2004, Certified 19 July 2004 (2004). El Dorado County general plan, final environmental impact report (EIR). Resolution No. 234-2004, State Clearinghouse No. 2001082030. Prepared by EDAW.
- El Dorado County. Adopted 19 July 2004, last amended 6 December 2016 (2016). 2004 El Dorado County General Plan A Plan for Managed Growth and Open Roads; A Plan for Quality Neighborhoods and Traffic Relief. Resolution No. 235-2004, State Clearinghouse No. 2001082030. Prepared by El Dorado County Planning Department, Placerville, CA.
- National Resources Conservation Service (NRCS). 21 September 2016. Soil Survey Geographic (SSURGO) database for El Dorado County, CA. USDA, NRCS. <https://websoilsurvey.nrcs.usda.gov/>
- Natural Resources Conservation Service (NRCS; formerly known as Soil Conservation Service). April 1974. Soil survey of El Dorado Area, California. USDA – Soil Conservation Service.
- Natural Resources Conservation Service (NRCS). Accessed May 2017. Official soil series descriptions (OSD). Soil Survey Staff, United States Department of Agriculture. <https://soilseries.sc.egov.usda.gov/>
- Sawyer, J. O., T. Keeler-Wolf, and J. M. Evens. 2009. A manual of California vegetation, 2nd ed. California Native Plant Society, Sacramento, CA.

VII. PREPARERS

Adrienne Levoy, B.S., Conservation and Resource Studies, University of California, Berkeley, CA. Over 9 years experience as a professional biologist. Conducts wildlife surveys, yellow-billed cuckoo, burrowing owl, and Swainson's hawk protocol surveys, biological resource evaluations, worker awareness training, and construction monitoring; prepares impact/mitigation analyses, and assists with permit application preparation. She prepares reports used in the CEQA/NEPA process that document resources, identify impacts, recommends mitigation measures, and assists with permit application preparation. She holds a USFWS recovery permit for listed yellow-billed cuckoo (TE-78073B-0) and a CDFW Scientific Collecting Permit (SC-13362).

Responsibilities: Report preparation.

Jessica Quinn, Ph.D., Ecology, University of California, Davis, CA. Over 8 years of experience as a professional ecologist. Conducts special-status plant and wildlife surveys; provides technical support for wetland delineations; and coordinates and prepares PES submissions. Project management, prepares CEQA documents and reports used in the CEQA/NEPA process that document resources, identify impacts, and recommend mitigation measures. She has managed and conducted wetland functional analyses, environmental risk assessments, environmental screening evaluations, and restoration design evaluations, and has received training in biology and survey techniques for CA red-legged frog, NEPA and Habitat Conservation Planning. Her background includes 13 additional years of experience managing and conducting ecological research on mammals, birds, and grassland ecology. Dr. Quinn holds a CDFW Rare, Threatened and Endangered Plant Voucher Collecting Permit (#2081(a)-16-053-V), and is an authorized individual on the CDFW Scientific Collecting Permit (SC-7617). Responsibilities: Project manager, report preparation.

Jeffery Little, Vice President, Sycamore Environmental. Over 24 years experience with preparation of NES, BA, and NEPA/CEQA compliance documents, impact analysis, agency formal and informal consultations and permitting. Project management, conducts special-status species surveys, jurisdictional delineations, and prepares mitigation and monitoring plans. CAD/ GIS Manager responsible for data collection, map creation, impact analyses, and report preparation. He holds a California Department of Fish and Wildlife Rare, Threatened and Endangered Plant Voucher Collecting Permit (2081(a)-14-078-V), and is an authorized individual on the CDFW Scientific Collecting Permit (SC-7617).

Responsibilities: Principal-in-Charge, QA/QC

Aramis Respass, GIS Analyst/ CAD Operator. Over 20 years experience in drafting and spatial analysis using AutoCAD map and ArcGIS for public and private projects. Prepares figures for biological and permitting documents such as project location maps, biological resource maps, wetlands/waters delineation maps, impact analysis maps, and other supporting graphics. Primary experience evolved from surveying and civil engineering practices to advanced GPS/GIS technology.

Responsibilities: Figure preparation and spatial analysis.

APPENDIX A

Plant and Wildlife Species Observed

Plant Species Observed. Taxonomy follows Baldwin et al. 2012.

Family	Scientific Name	Common Name	N/I ¹	CAL-IPC ²
GYMNOSPERMS				
EUDICOTS				
Asteraceae	<i>Centromadia fitchii</i>	Spikeweed	N	
	<i>Centaurea solstitialis</i>	Yellow star-thistle	I	High
	<i>Calycadenia multiglandulosa</i>	Calycadenia	N	
	<i>Lactuca serriola</i>	Prickly lettuce	I	
	<i>Leontodon saxatilis</i>	Hairy hawkbit	I	
	<i>Psilocarphus tenellus</i>	Slender woolly-marbles	N	
Brassicaceae	<i>Capsella bursa-pastoris</i>	Shepherd's purse	I	
Euphorbiaceae	<i>Croton setigerus</i>	Turkey-mullein	N	
Fabaceae	<i>Trifolium glomeratum</i>	Clustered clover	I	
Fagaceae	<i>Quercus kelloggii</i>	California black oak	N	
Geraniaceae	<i>Erodium botrys</i>	Storksbill, filaree	I	
Lamiaceae	<i>Trichostema lanceolatum</i>	Vinegar weed	N	
Plantaginaceae	<i>Kickxia elatine</i>	Kickxia	I	
	<i>Plantago erecta</i>	Plantain	N	
Polemoniaceae	<i>Navarretia intertexta</i>	Navarretia	N	
Polygonaceae	<i>Polygonum aviculare</i>	Knotweed, knotgrass	I	
Simaroubaceae	<i>Ailanthus altissima</i>	Tree of heaven	I	Moderate
Solanaceae	<i>Nicotiana acuminata</i> var. <i>multiflora</i>	Tobacco	I	
MONOCOTS				
Poaceae	<i>Brachypodium distachyon</i>	False brome	I	Moderate
	<i>Bromus diandrus</i>	Ripgut grass	I	Moderate
	<i>Bromus hordeaceus</i>	Soft chess	I	Limited
	<i>Hordeum murinum</i> ssp. <i>leporinum</i>	Hare barley	I	Moderate

¹ N = Native to CA; I = Introduced.

² Negative ecological impact according to the California Invasive Plant Council (Cal-IPC 2006).

Wildlife Species Observed

COMMON NAME	SCIENTIFIC NAME
BIRDS	
Acorn woodpecker	<i>Melanerpes formicivorus</i>
American crow	<i>Corvus brachyrhynchos</i>
American robin	<i>Turdus migratorius</i>
Anna's hummingbird	<i>Calypte anna</i>
Ash-throated flycatcher	<i>Myiarchus cinerascens</i>
Blue-gray gnatcatcher	<i>Polioptila caerulea</i>
California scrub-jay	<i>Aphelocoma californica</i>
Eurasian collared dove	<i>Streptopelia decaocto</i>
House finch	<i>Carpodacus mexicanus</i>
Mourning dove	<i>Zenaida macroura</i>
Turkey vulture	<i>Cathartes aura</i>
Western bluebird	<i>Sialia mexicana</i>

[This page intentionally left blank]

APPENDIX B

USFWS Species List

[This page intentionally left blank]



United States Department of the Interior



FISH AND WILDLIFE SERVICE
Sacramento Fish And Wildlife Office
Federal Building
2800 Cottage Way, Room W-2605
Sacramento, CA 95825-1846
Phone: (916) 414-6600 Fax: (916) 414-6713

In Reply Refer To:

July 06, 2017

Consultation Code: 08ESMF00-2017-SLI-2534

Event Code: 08ESMF00-2017-E-06925

Project Name: AT&T Pleasant Valley Project

Subject: List of threatened and endangered species that may occur in your proposed project location, and/or may be affected by your proposed project

To Whom It May Concern:

The enclosed species list identifies threatened, endangered, proposed and candidate species, as well as proposed and final designated critical habitat, under the jurisdiction of the U.S. Fish and Wildlife Service (Service) that may occur within the boundary of your proposed project and/or may be affected by your proposed project. The species list fulfills the requirements of the Service under section 7(c) of the Endangered Species Act (Act) of 1973, as amended (16 U.S.C. 1531 et seq.).

Please follow the link below to see if your proposed project has the potential to affect other species or their habitats under the jurisdiction of the National Marine Fisheries Service:

http://www.nwr.noaa.gov/protected_species/species_list/species_lists.html

New information based on updated surveys, changes in the abundance and distribution of species, changed habitat conditions, or other factors could change this list. Please feel free to contact us if you need more current information or assistance regarding the potential impacts to federally proposed, listed, and candidate species and federally designated and proposed critical habitat. Please note that under 50 CFR 402.12(e) of the regulations implementing section 7 of the Act, the accuracy of this species list should be verified after 90 days. This verification can be completed formally or informally as desired. The Service recommends that verification be completed by visiting the ECOS-IPaC website at regular intervals during project planning and implementation for updates to species lists and information. An updated list may be requested through the ECOS-IPaC system by completing the same process used to receive the enclosed list.

The purpose of the Act is to provide a means whereby threatened and endangered species and the ecosystems upon which they depend may be conserved. Under sections 7(a)(1) and 7(a)(2) of the Act and its implementing regulations (50 CFR 402 et seq.), Federal agencies are required to

utilize their authorities to carry out programs for the conservation of threatened and endangered species and to determine whether projects may affect threatened and endangered species and/or designated critical habitat.

A Biological Assessment is required for construction projects (or other undertakings having similar physical impacts) that are major Federal actions significantly affecting the quality of the human environment as defined in the National Environmental Policy Act (42 U.S.C. 4332(2) (c)). For projects other than major construction activities, the Service suggests that a biological evaluation similar to a Biological Assessment be prepared to determine whether the project may affect listed or proposed species and/or designated or proposed critical habitat. Recommended contents of a Biological Assessment are described at 50 CFR 402.12.

If a Federal agency determines, based on the Biological Assessment or biological evaluation, that listed species and/or designated critical habitat may be affected by the proposed project, the agency is required to consult with the Service pursuant to 50 CFR 402. In addition, the Service recommends that candidate species, proposed species and proposed critical habitat be addressed within the consultation. More information on the regulations and procedures for section 7 consultation, including the role of permit or license applicants, can be found in the "Endangered Species Consultation Handbook" at:

<http://www.fws.gov/endangered/esa-library/pdf/TOC-GLOS.PDF>

Please be aware that bald and golden eagles are protected under the Bald and Golden Eagle Protection Act (16 U.S.C. 668 et seq.), and projects affecting these species may require development of an eagle conservation plan (http://www.fws.gov/windenergy/eagle_guidance.html). Additionally, wind energy projects should follow the wind energy guidelines (<http://www.fws.gov/windenergy/>) for minimizing impacts to migratory birds and bats.

Guidance for minimizing impacts to migratory birds for projects including communications towers (e.g., cellular, digital television, radio, and emergency broadcast) can be found at: <http://www.fws.gov/migratorybirds/CurrentBirdIssues/Hazards/towers/towers.htm>; <http://www.towerkill.com>; and <http://www.fws.gov/migratorybirds/CurrentBirdIssues/Hazards/towers/comtow.html>.

We appreciate your concern for threatened and endangered species. The Service encourages Federal agencies to include conservation of threatened and endangered species into their project planning to further the purposes of the Act. Please include the Consultation Tracking Number in the header of this letter with any request for consultation or correspondence about your project that you submit to our office.

Attachment(s):

- Official Species List
-

Official Species List

This list is provided pursuant to Section 7 of the Endangered Species Act, and fulfills the requirement for Federal agencies to "request of the Secretary of the Interior information whether any species which is listed or proposed to be listed may be present in the area of a proposed action".

This species list is provided by:

Sacramento Fish And Wildlife Office

Federal Building

2800 Cottage Way, Room W-2605

Sacramento, CA 95825-1846

(916) 414-6600

Project Summary

Consultation Code: 08ESMF00-2017-SLI-2534

Event Code: 08ESMF00-2017-E-06925

Project Name: AT&T Pleasant Valley Project

Project Type: COMMUNICATIONS TOWER

Project Description: AT&T intends to construct a wireless telecommunications facility at 4559 Strauss Drive, Placerville, in central El Dorado County this summer. The proposed AT&T Pleasant Valley Site CVL03180 Project (Project) facility tower will be a new 153-ft monopole tower with a new GPS antenna, six wireless antennas, six remote radio units (RRUs), and one surge suppressor mounted at 150 ft; six wireless antennas and 12 RRUs mounted at 140 ft; and nine RRUs and three surge protectors on a collar mount directly below the upper antennas. In the future, the tower can also accommodate two 4-ft diameter microwave dishes mounted at 132.5 ft. Future antennas can be mounted by other carriers at approximately 125 and 110 ft. The tower has been designed with pine foliage to match the existing surrounding trees. The foliage would extend horizontally approximately 7 ft above the top of the structure to an overall structure height of approximately 160 ft. Antennas will be concealed with socks. The monopole “trunk” and RRUs will be painted brown.

Project Location:

Approximate location of the project can be viewed in Google Maps:

<https://www.google.com/maps/place/38.68417815330555N120.66195398571526W>

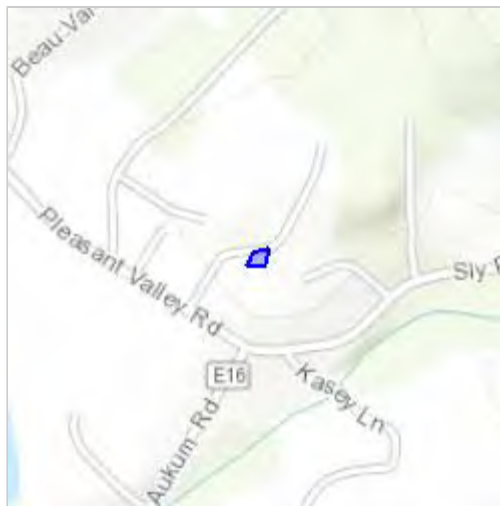

Counties: El Dorado, CA

Endangered Species Act Species

There is a total of 3 threatened, endangered, or candidate species on your species list. Species on this list should be considered in an effects analysis for your project and could include species that exist in another geographic area. For example, certain fish may appear on the species list because a project could affect downstream species. See the "Critical habitats" section below for those critical habitats that lie wholly or partially within your project area. Please contact the designated FWS office if you have questions.

Amphibians

NAME	STATUS
California Red-legged Frog (<i>Rana draytonii</i>) There is a final critical habitat designated for this species. Your location is outside the designated critical habitat. Species profile: https://ecos.fws.gov/ecp/species/2891	Threatened

Fishes

NAME	STATUS
Delta Smelt (<i>Hypomesus transpacificus</i>) There is a final critical habitat designated for this species. Your location is outside the designated critical habitat. Species profile: https://ecos.fws.gov/ecp/species/321	Threatened
Steelhead (<i>Oncorhynchus (=Salmo) mykiss</i>) Population: Northern California DPS There is a final critical habitat designated for this species. Your location is outside the designated critical habitat. Species profile: https://ecos.fws.gov/ecp/species/1007	Threatened

Critical habitats

There are no critical habitats within your project area.

[This page intentionally left blank]

APPENDIX C

CNDDDB Summary Report CNPS Inventory Query

[This page intentionally left blank]



Selected Elements by Scientific Name

California Department of Fish and Wildlife

California Natural Diversity Database



Query Criteria: Quad (Camino) OR Garden Valley OR Pollock Pines OR Slate Mtn. OR Sly Park OR Omo Ranch OR Aukum OR Fiddletown OR Placerville

Table with 7 columns: Species, Element Code, Federal Status, State Status, Global Rank, State Rank, Rare Plant Rank/CDFW SSC or FP. Rows include species like Accipiter gentilis, Agelaius tricolor, Aplodontia rufa californica, etc.



Selected Elements by Scientific Name
California Department of Fish and Wildlife
California Natural Diversity Database



Species	Element Code	Federal Status	State Status	Global Rank	State Rank	Rare Plant Rank/CDFW SSC or FP
<i>Myotis thysanodes</i> fringed myotis	AMACC01090	None	None	G4	S3	
<i>Myotis volans</i> long-legged myotis	AMACC01110	None	None	G5	S3	
<i>Myotis yumanensis</i> Yuma myotis	AMACC01020	None	None	G5	S4	
<i>Packera layneae</i> Layne's ragwort	PDAST8H1V0	Threatened	Rare	G2	S2	1B.2
<i>Pekania pennanti</i> fisher - West Coast DPS	AMAJF01021	Proposed Threatened	Candidate Threatened	G5T2T3Q	S2S3	SSC
<i>Phacelia stebbinsii</i> Stebbins' phacelia	PDHYD0C4D0	None	None	G3	S3	1B.2
<i>Rana boylei</i> foothill yellow-legged frog	AAABH01050	None	Candidate Threatened	G3	S3	SSC
<i>Rana draytonii</i> California red-legged frog	AAABH01022	Threatened	None	G2G3	S2S3	SSC
<i>Rana sierrae</i> Sierra Nevada yellow-legged frog	AAABH01340	Endangered	Threatened	G1	S1	WL
<i>Rhynchospora capitellata</i> brownish beaked-rush	PMCYP0N080	None	None	G5	S1	2B.2
<i>Riparia riparia</i> bank swallow	ABPAU08010	None	Threatened	G5	S2	
<i>Sacramento-San Joaquin Foothill/Valley Ephemeral Stream</i> Sacramento-San Joaquin Foothill/Valley Ephemeral Stream	CARA2130CA	None	None	GNR	SNR	
<i>Sphagnum Bog</i> Sphagnum Bog	CTT51110CA	None	None	G3	S1.2	
<i>Strix nebulosa</i> great gray owl	ABNSB12040	None	Endangered	G5	S1	
<i>Viburnum ellipticum</i> oval-leaved viburnum	PDCPR07080	None	None	G4G5	S3?	2B.3

Record Count: 33

Plant List

Inventory of Rare and Endangered Plants

11 matches found. Click on scientific name for details

Search Criteria

California Rare Plant Rank is one of [1A, 1B, 2A, 2B], Found in Quads 3812077, 3812076, 3812075, 3812067, 3812066, 3812065, 3812057 3812056 and 3812055;

[Modify Search Criteria](#)
[Export to Excel](#)
[Modify Columns](#)
[Modify Sort](#)
[Display Photos](#)

Scientific Name	Common Name	Family	Lifeform	Blooming Period	CA Rare Plant Rank	State Rank	Global Rank
Arctostaphylos nissenana	Nissenan manzanita	Ericaceae	perennial evergreen shrub	Feb-Mar	1B.2	S1	G1
Calochortus clavatus var. avius	Pleasant Valley mariposa lily	Liliaceae	perennial bulbiferous herb	May-Jul	1B.2	S2	G4T2
Calystegia vanzuukiae	Van Zuuk's morning-glory	Convolvulaceae	perennial rhizomatous herb	May-Aug	1B.3	S2	G2Q
Carex cyrtostachya	Sierra arching sedge	Cyperaceae	perennial herb	May-Aug	1B.2	S2	G2
Chlorogalum grandiflorum	Red Hills soaproot	Agavaceae	perennial bulbiferous herb	May-Jun	1B.2	S2	G2
Horkelia parryi	Parry's horkelia	Rosaceae	perennial herb	Apr-Sep	1B.2	S2	G2
Lewisia serrata	saw-toothed lewisia	Montiaceae	perennial herb	May-Jun	1B.1	S2	G2
Packera layneae	Layne's ragwort	Asteraceae	perennial herb	Apr-Aug	1B.2	S2	G2
Phacelia stebbinsii	Stebbins' phacelia	Hydrophyllaceae	annual herb	May-Jul	1B.2	S3	G3
Rhynchospora capitellata	brownish beaked-rush	Cyperaceae	perennial herb	Jul-Aug	2B.2	S1	G5
Viburnum ellipticum	oval-leaved viburnum	Adoxaceae	perennial deciduous shrub	May-Jun	2B.3	S3?	G4G5

Suggested Citation

California Native Plant Society, Rare Plant Program. 2017. Inventory of Rare and Endangered Plants of California (online edition, v8-03 0.39). Website <http://www.rareplants.cnps.org> [accessed 21 July 2017].

Search the Inventory

[Simple Search](#)

[Advanced Search](#)

[Glossary](#)

Information

[About the Inventory](#)

[About the Rare Plant Program](#)

[CNPS Home Page](#)

[About CNPS](#)

[Join CNPS](#)

Contributors

[The Calflora Database](#)

[The California Lichen Society](#)

[This page intentionally left blank]

APPENDIX D

Photographs



Photo 1. View from northeast corner of the BSA to the southwest and the residence south of the BSA, toward location of proposed gravel access road. 13 July 2017.



Photo 2. View facing southeast of the oak woodland to the south of the BSA, toward area of proposed underground power conduit installation. 13 July 2017.

[This page intentionally left blank]



Photo 3. View from the north facing southeast of the fence bordering the east side of the BSA. 13 July 2017



Photo 4. View facing west towards the gravel road along the north end of the BSA, toward area of proposed gravel access pad. 13 July 2017.

[This page intentionally left blank]