

PFF:km  
17-14-240.ord  
10/21/10



ORDINANCE NO. 4954

**THE BOARD OF SUPERVISORS OF THE COUNTY OF EL DORADO DOES ORDAIN AS FOLLOWS:**

Section 1. Section 17.14.240 of Chapter 17.14 of Title 17 of the El Dorado County Ordinance Code is hereby added as follows:

**17.14.240 Wind Energy Conversion Systems**

- A. Purpose and Intent.** The purpose of this Section is to comply with California Government Code Section 65893 which encourages local agencies to adopt zoning standards that enable construction of small wind energy conversion systems for on-site home, farm, and small commercial use. The intent is to provide standards and regulations for the safe and effective construction and use of these systems, as well as for larger, utility-scale systems that can potentially be developed within the County, based on the State Energy Commission's *Wind Resource Potential Maps*.
- B. Applicability.** This Section shall apply to wind energy conversion system (WECS) used for electrical energy generation. Microturbines and Small WECS shall be regulated as accessory structures in all zones while large and utility-scale systems shall be regulated as a primary use in non-residential zones, subject to permitting requirements under Subsection F.
- C. Definitions.** The following definitions shall apply to this Section:
- "WECS", or "system", means a machine which can convert the kinetic energy in wind into a usable form of electrical or mechanical energy, such as a wind turbine or windmill. As used within this Section, a WECS includes all parts of the turbine and the tower upon which it is installed, but does not include power transmission equipment. Turbines are classified as being either on a horizontal or a vertical axis configuration, as shown below:

**EXAMPLE: WIND TURBINE CONFIGURATIONS**

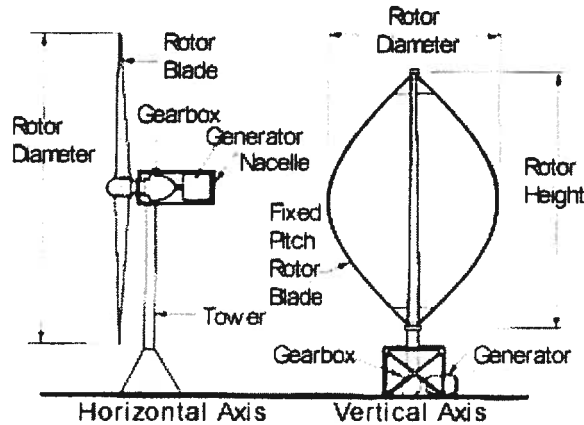

“Microturbine” means a WECS that generate one kilowatt or less.

“Small WECS” means one system with a rated capacity of 50 kilowatts (kw) or less, to be used to provide electrical energy on site. Excess electricity can be sold back to the utility supplier through net metering, net billing, or similar programs.

“Utility Scale WECS” means one system with a rated capacity of more than 100 kw.

“Wind Farm” means two or more utility-scale WECS on the same parcel or group of adjacent parcels under common ownership. A wind farm may cover an extended area, but the land between the systems may be used for agricultural or other purposes.

“Height of tower” means the height from base grade to the top of the system, including the uppermost extension of any horizontal axis blades.

**D. Permit Requirements.** WECS are permitted under Table 17.14.240.1 for all use types subject to the following rated capacity thresholds designated below:

- “P” Permitted use
- “A” Use permitted subject to issuance of an Administrative Permit  
(17.22.V)
- “MUP” Use permitted subject to issuance of a Minor Use Permit  
(17.22.VI)
- “SUP” Use permitted subject to issuance of a Special Use Permit  
(17.22.VII)

Total rated capacity designated by a dash (–) is not permitted for the use type.

**Table 17.14.240.1 WECS Use Matrix**

	<b>RATED CAPACITY</b>				
	<b>Per Individual System and Cumulative System Capacity</b>				
	Microturbine	Small WECS		Large and Utility Scale WECS	
<b>ZONES</b>	1Kw or less <sup>1</sup>	>1Kw to less than 10Kw; 20 Kw total	10Kw to less than 50Kw; 100 Kw total	50Kw to less than 100Kw; 200Kw total	100Kw or greater; 200 Kw or greater total
Residential (all), RE-10, U, Tahoe Residential	P	A	SUP	—	—
Commercial (all), Industrial, R&D, TC, MR	P	A	A	SUP	SUP
Agricultural, Residential Agricultural, TPZ	P	A	A	A	SUP
Notes: <sup>1</sup> Maximum cumulative total as provided in Paragraph E					

**E. Number of WECS Units.**

1. **Microturbines.** The maximum number of microturbines that may be installed on a lot is as follows:
  - a. Residential lots less than five acres in size may install a maximum of 5 microturbines.
  - b. Residential and agricultural lots five acres or greater in size may install a maximum of 10 microturbines.
  - c. Agricultural, Residential Agricultural, TPZ, Commercial, Industrial, and R&D zoned lots may install up to 25 microturbines.

2. **Small WECS.** The maximum number of small WECS units that may be installed on one lot shall be based on the following acreage requirements:
    - a. For lots one acre to less than 10 acres, one WECS shall be allowed.
    - b. For lots 10 acres to less than 20 acres, two WECS shall be allowed.
    - c. For lots 20 acres or greater, a maximum of three WECS shall be allowed.
    - d. If the WECS generate greater than one to five kilowatts each, and are limited to 50 feet in height, a maximum of two WECS may be installed per five acres. Additionally, the separation between them may be reduced to twice the height of the tallest tower.
- F. Development Standards.** The following development standards shall apply to all WECS except that microturbines shall comply with Paragraphs 1, 2, 5, 8, 10, 11, and 13:
1. **General Development Standards.** General development standards shall be applied as set forth in Table 17.14.240.2.

**Table 17.14.240.2**

<b>DEVELOPMENT STANDARDS</b>			
<b>Rated Capacity (per WECS Unit)</b>	<b>Minimum Lot Size</b>	<b>Setbacks – Freestanding Systems</b>	<b>Maximum Height</b>
Microturbines Up to 1 kw	Subject to Zone Standards		
Greater than 1 – 10kw	1 acre	Greater of tower height or zone standard	80 feet
Greater than 10 to 50kw	5 acres	Tower height	100 feet
Greater than 50 – 100kw	10 acres	Tower height x 2	100 feet
Greater than 100kw	20 acres per each Megawatt	Greater of tower height x 3 or 500 feet	Manufacturer’s Recommendations

2. **Safety.** All WECS shall be completely enclosed by a locked, protective fence at least six feet high unless located upon a roof or other location with limited access.
3. **Guy Wires.** Anchor points of any guy wires for a system tower shall be located within the property that the system is located on. Guy wires shall not cross any above-ground electric transmission or distribution lines. The points of attachment for the guy wires shall be either enclosed by a fence six feet high or sheathed in bright orange or yellow coverings from three to eight feet above the ground.
4. **Tower Access.** Towers must either:
  - a. Have tower-climbing apparatus located no closer than 12 feet from the ground;
  - b. Have a locked anti-climb device installed on the tower;
  - c. Have a tower-access limitation program approved by the review authority.
5. **Rotor Safety.** Each WECS must be equipped with both manual and automatic controls to limit the rotational speed of the blade within the design limits of the rotor.
6. **Electromagnetic Interference.** The WECS shall be designed, installed and operated so that no disrupting electromagnetic interference is caused. Disruptive

interference from the facility shall be promptly rectified to include the discontinued operation of one or more WECS.

7. **Utility Notification and Undergrounding.** For inter-connected systems, no wind turbine shall be installed until evidence has been given that the electric utility service provider has been notified and has indicated that the proposed interconnection is acceptable. On-site electrical wires associated with the system shall be installed underground, except for “tie-ins” to the electric utility service provider and its transmission poles, towers, and lines. This standard may be modified by variance if the project terrain is found to be unsuitable due to the need for excessive grading, biological impacts, or similar factors.
8. **Noise.** All WECS shall be subject to the noise standards under General Plan Policies 6.5.1.10 and 6.5.1.11. Measurement of sound levels shall not be adjusted for, or averaged with, non-operating periods.
9. **Wind Farm Site Access.** Construction of on site roadways shall be minimized. Temporary access roads utilized for initial installation shall be regraded and revegetated to its natural condition after completion of installation.
10. **Site Aesthetics.** WECS shall be designed and located in the following manner to minimize adverse visual impacts from public viewing areas and private property:
  - a. Structural components including, but not limited to, towers, blades, and fencing shall be of a nonreflective, unobtrusive color.
  - b. To the greatest extent feasible, the WECS shall not project above the top of ridgelines.
  - c. When adjacent to a designated scenic corridor, WECS shall not cause a significantly adverse visual impact either from the corridor, or on a designated scenic viewshed, subject to the requirement under Paragraph F.4.
11. **Exterior Lighting.** Exterior lighting on any structure associated with the WECS shall be prohibited, with the exception of that specifically required by the Federal Aviation Administration.
12. **Signs.** Signage shall be considered as part of a Special Use Permit, and shall be limited to the following:
  - a. Signs warning of high voltage electricity shall be posted at a height of five feet above the ground on stationary portions of the WECS or its tower, and at gated entry points to the project site.

- b. No advertising sign or logo shall be placed or painted on any WECS or tower.
- c. For wind farms, no more than two identification signs relating to the development shall be located on the project site.
- d. Signs shall not exceed 16 square feet in surface area or eight feet in height.

13. Compliance with FAA Regulations. Small wind energy systems must comply with applicable FAA regulations, including any necessary approvals for installations close to airports.

**G. Application Submittal Requirements.** All applications for Administrative or Conditional Use Permit for a WECS shall include the following:

- 1. Delineation of the direction of the prevailing winds across the project site;
- 2. Distance to residentially zoned lots, public and private airports and airstrips, public and private schools within one-quarter mile of the proposed project as measured from its nearest property line;
- 3. Photo simulations of the proposed WECS as seen from residentially zoned lots and public viewsheds within one mile of the project site;
- 4. Maximum generating capacity of the WECS unit(s) proposed to be installed;
- 5. Manufacturer's specifications documenting maximum noise levels generated by the WECS on the surrounding area;
- 6. A statement by the manufacturer certifying that the rotor and overspeed controls have been designed and fabricated for the proposed use in accordance with good engineering practice, and have been approved by the California Energy Commission or certified by a national program, such as National Electrical Code (NEC), American National Standards Institute (ANSI), or Underwriters Laboratories (UL);
- 7. Certification by a state licensed structural, mechanical or civil engineer that the tower structures are designed and constructed in compliance with the pertinent provisions of the Uniform Building Code and National Electric Code;
- 8. Written evidence that the electric utility service provider for the proposed site has been informed of the applicant's intent to install an interconnected customer-owned electricity generator. If the applicant does not plan to connect the system to the electricity grid, the applicant shall include a statement to that effect;

9. A description of the proposed measures to minimize adverse noise, transmission interference, visual, and safety impacts to adjacent properties, and methods to prevent public access to the structure.

Section 2. This ordinance shall become effective thirty (30) days following adoption hereof.

PASSED AND ADOPTED by the Board of Supervisors of the County of El Dorado at a regular meeting of said Board, held on the 15 day of November, 2010, by the following vote of said Board:

Ayes: James R. Sweeney, John Knight  
Raymond J. Nutting, Ron Briggs, Norma Santiago

**ATTEST**  
**SUZANNE ALLEN DE SANCHEZ**  
Clerk of the Board of Supervisors

By \_\_\_\_\_

Deputy Clerk

Noes: none  
Absent: none

  
Chairman, Board of Supervisors

Norma Santiago, Chair

**APPROVED AS TO FORM**  
**LOUIS B. GREEN**  
**COUNTY COUNSEL**

By \_\_\_\_\_

Name Paula Frantz  
Title Counsel

**I CERTIFY THAT:**

THE FOREGOING INSTRUMENT IS A CORRECT COPY OF THE ORIGINAL ON FILE IN THIS OFFICE

Date \_\_\_\_\_

**ATTEST: SUZANNE ALLEN DE SANCHEZ**, Clerk of the Board of Supervisors  
of the County of El Dorado, State of California.

By \_\_\_\_\_

Deputy Clerk