

OWNER/APPLICANT  
 SERRANO ASSOCIATES, LLC  
 4525 SERRANO PARKWAY  
 EL DORADO HILLS, CA 95762

ENGINEER  
 R.E.Y. ENGINEERS, INC.  
 905 SUTTER STREET, SUITE 200  
 FOLSOM, CA 95630

MAP SCALE  
 1"=60'

CONTOUR INTERVAL  
 MINOR CONTOUR INTERVAL = 1'  
 MAJOR CONTOUR INTERVAL = 5'

SOURCE OF TOPOGRAPHY  
 AERIAL PHOTOGRAPHY

SECTION TOWNSHIP & RANGE  
 POR OF SEC. 31 & 32, T.10N., R.9E., M.D.M

ASSESSOR'S PARCEL NUMBERS  
 123-570-03 & 123-570-04

EXISTING/PROPOSED ZONING  
 CP-PD, R1-PD/R1-PD

PROPOSED USE  
 148 - SINGLE FAMILY RESIDENTIAL  
 9 - LANDSCAPE (LOTS A - I)  
 1 - PASSIVE PARK

LOT SIZES  
 MINIMUM LOT SIZE - 5,003 SF  
 AVERAGE LOT SIZE - 6,369 SF  
 MAXIMUM LOT SIZE - 12,565 SF

WATER, RECYCLED WATER  
 SUPPLY & SEWAGE DISPOSAL  
 EL DORADO IRRIGATION DISTRICT

FIRE PROTECTION  
 EL DORADO HILLS COUNTY  
 WATER/FIRE DISTRICT

PARK AND RECREATION  
 EL DORADO HILLS COMMUNITY  
 SERVICES DISTRICT

SCHOOL DISTRICT  
 RESCUE UNION SCHOOL DISTRICT

DATE OF PREPARATION  
 APRIL 5, 2016

ENGINEERS CERTIFICATE  
 I HEREBY CERTIFY THAT TO THE BEST OF MY KNOWLEDGE  
 THE LAND DEVELOPMENT KNOWN AS VILLAGE J5 & J6 OF THE  
 EL DORADO HILLS SPECIFIC PLAN HAS BEEN SUBMITTED IN  
 ACCORDANCE WITH THE SPECIFICATIONS AND GUIDELINES  
 ESTABLISHED BY THE COUNTY OF EL DORADO.

DONALD E. MOOREMCK R.C.E. 42556 DATE

PHASING PLAN NOTICE  
 THE FILING OF MULTIPLE FINAL MAPS WILL BE COMPLETED  
 FOR THIS PROJECT. THIS PHASING PLAN IS APPROXIMATE  
 ONLY AND BY PROVIDING THIS NOTICE, THE SUBDIVIDER  
 SHALL NOT BE REQUIRED TO EXERCISE THE NUMBER OR  
 CONFIGURATION OF THE PROPOSED MULTIPLE FINAL MAPS  
 FROM THE SUBDIVISION MAP ACT, 2002 EDITION SECTION  
 65456.11.

PLANNING COMMISSION: \_\_\_\_\_  
 APPROVAL/DATE: \_\_\_\_\_  
 BOARD OF SUPERVISORS: \_\_\_\_\_  
 APPROVAL/DATE: \_\_\_\_\_

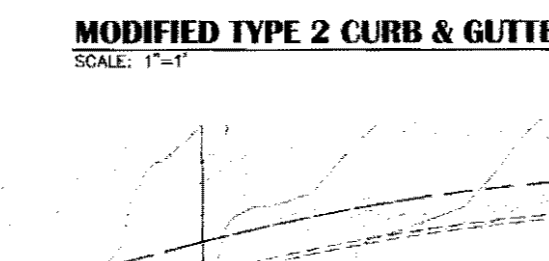
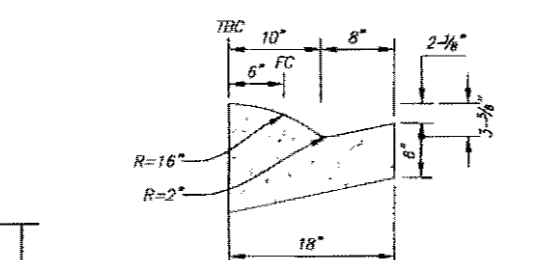
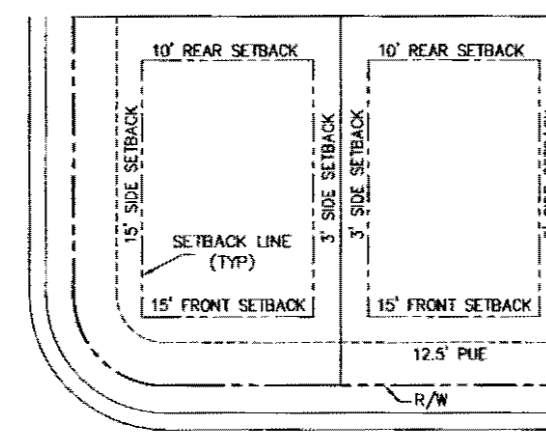

# SERRANO VILLAGE J5 & J6

## TENTATIVE SUBDIVISION MAP

EL DORADO COUNTY SEPTEMBER 2016 CALIFORNIA

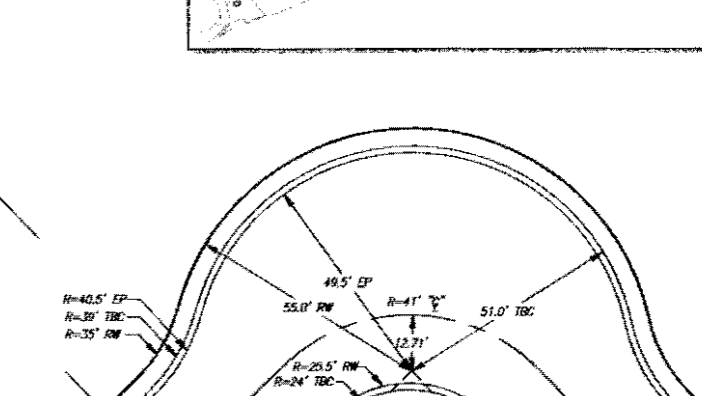
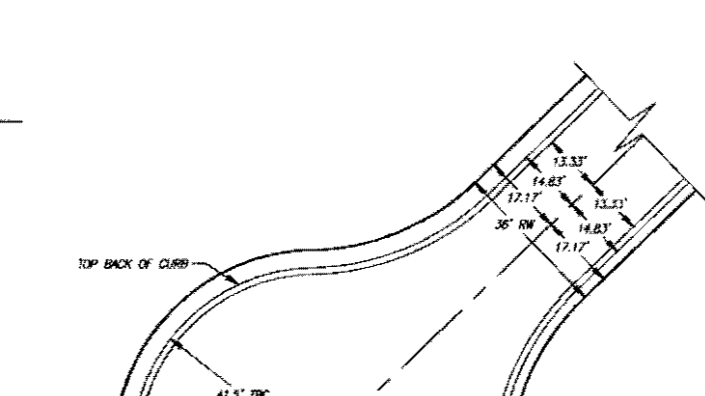
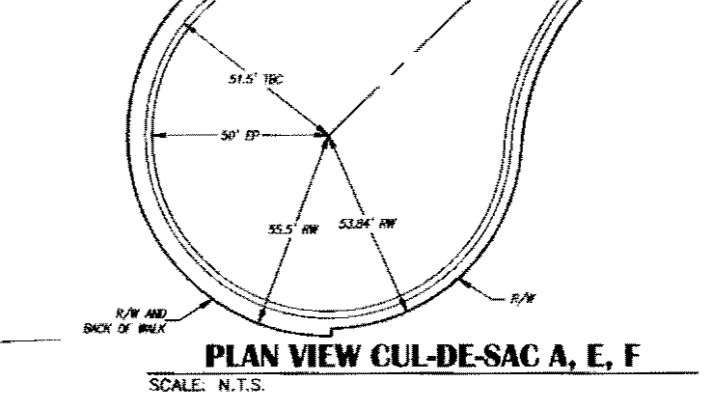
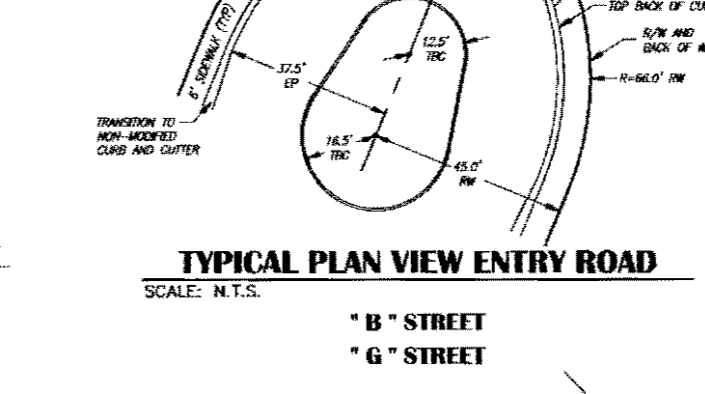
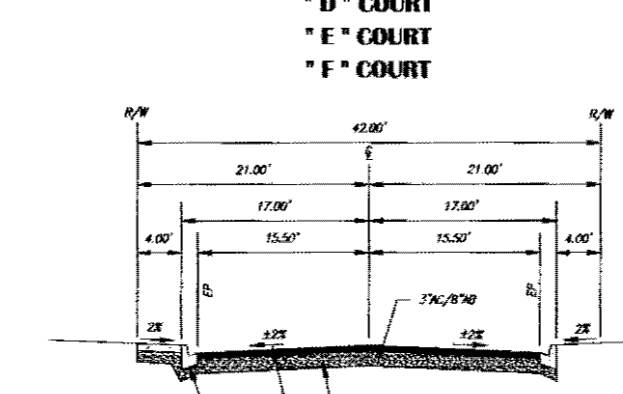
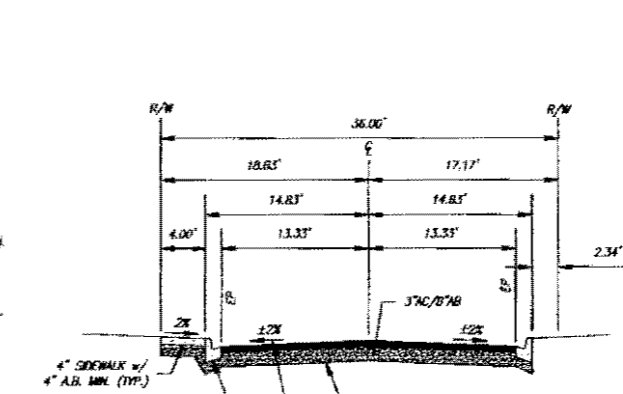
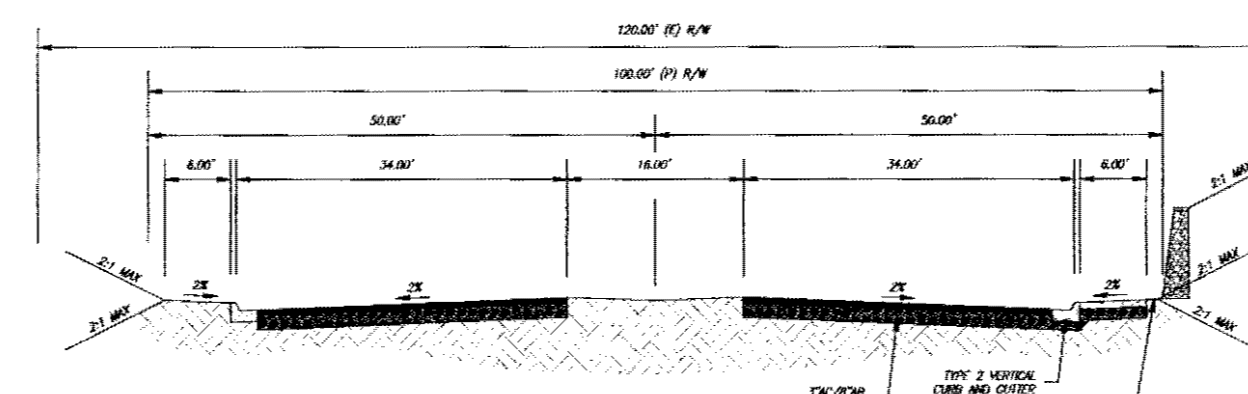
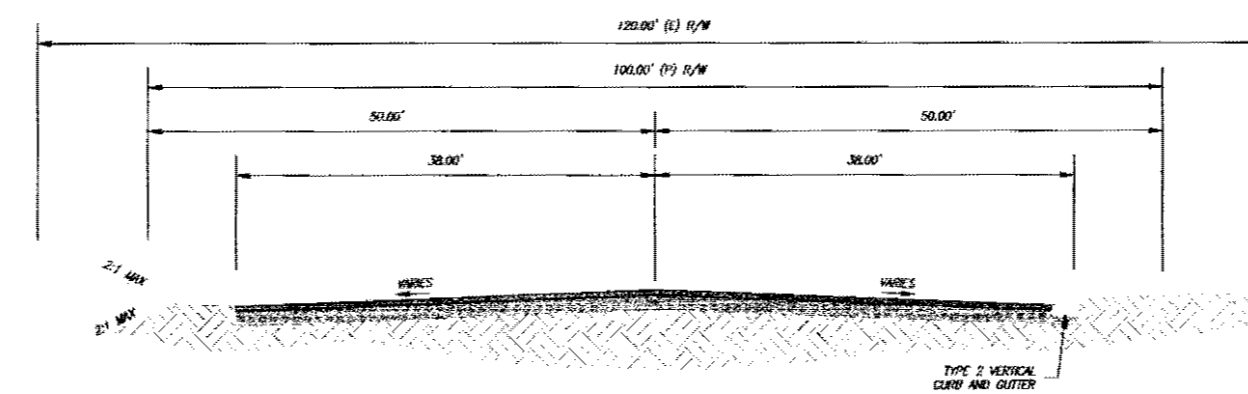

TOTAL AREA	21.63 Acres
RESIDENTIAL LOTS	7.04 Acres
LANDSCAPE LOT A	0.16 Acres
LANDSCAPE LOT B	0.44 Acres
LANDSCAPE LOT C	0.20 Acres
LANDSCAPE LOT D	0.08 Acres
LANDSCAPE LOT E	0.07 Acres
LANDSCAPE LOT F	1.96 Acres
LANDSCAPE LOT G	1.08 Acres
LANDSCAPE LOT H	0.15 Acres
LANDSCAPE LOT I	0.39 Acres
PASSIVE PARK	2.83 Acres +/-
TOTAL	36.03 Acres +/-
TOTAL UNITS	148 units
GROSS AREA	36.03 Acres
GROSS DENSITY	4.11 du/ac

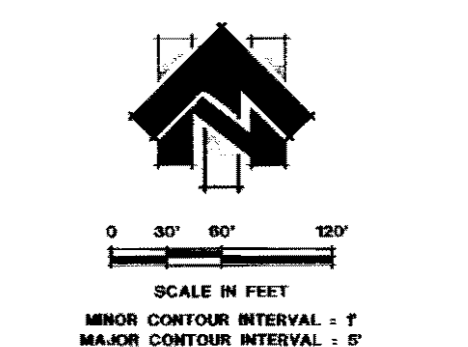
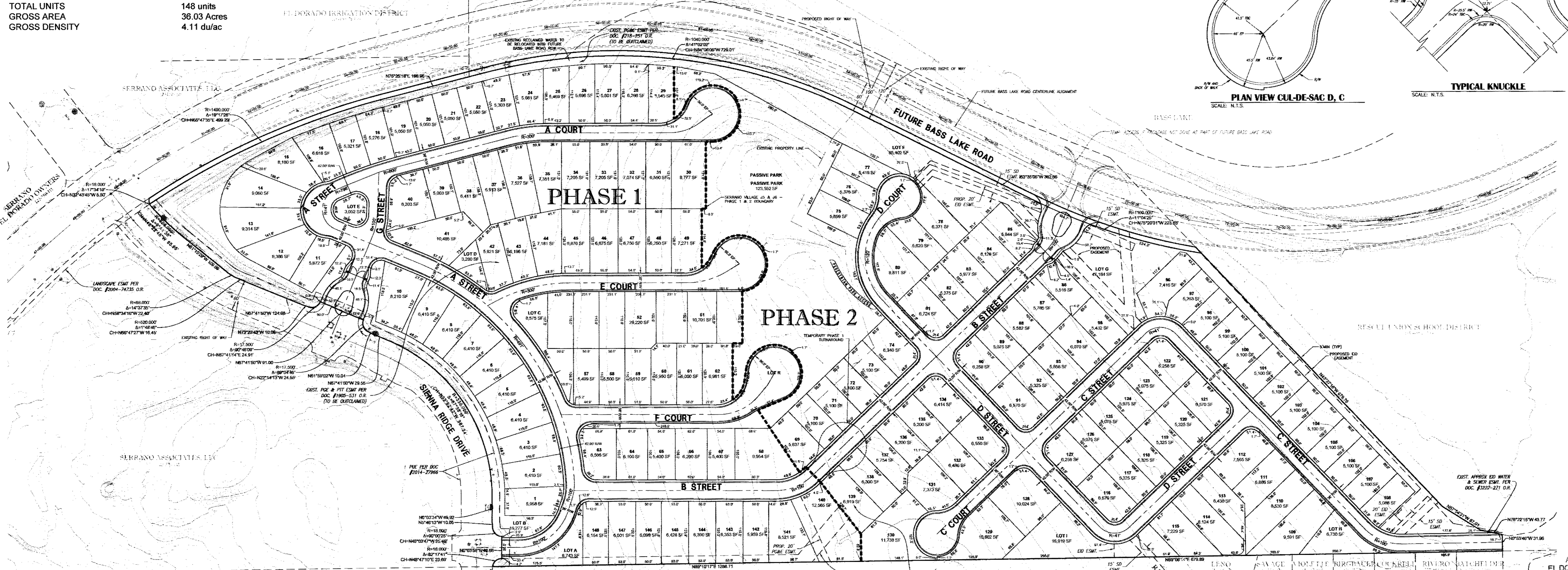

**SERRANO**  
 905 SUTTER STREET, SUITE 200  
 FOLSOM, CA 95630  
 R.E.Y. ENGINEERS, INC.  
 Civil Engineers / Land Surveyors



APPROVED  
 EL DORADO COUNTY  
 PLANNING COMMISSION  
 DATE: June 27, 2017  
 BY: *Roger J. ...*  
 EXECUTIVE SECRETARY