

# CONTRACT ROUTING SHEET

Date Prepared: 04/30/2010

Need Date: 05/15/2010

**PROCESSING DEPARTMENT:**

Department: Air Quality Management District

Dept. Contact: Marcella McTaggart

Phone #: 5306

Department \_\_\_\_\_

Head Signature: *georgia Siwa*

**CONTRACTOR:**

Name: El Dorado County Department of Transportation

Address: 2850 Fairlane Ct. Placerville, CA 95667

Attn: James Ware Director of Transportation

Phone: (530) 621-5900

**CONTRACTING DEPARTMENT:** EMD/AQMD-PLEASE CHARGE TO 422100

Service Requested: Review of Contract for Use of AB 2766 Funds

Contract Term: 6/30/2011 Contract/Amendment Value: \$190,520.00

Compliance with Human Resources requirements? Yes:  No:

Compliance verified by: \_\_\_\_\_

**COUNTY COUNSEL:** (Must approve all contracts and MOU's)

Approved:  Disapproved:  Date: 5/18/10 By: *[Signature]*

Approved:  Disapproved:  Date: \_\_\_\_\_ By: \_\_\_\_\_

EL DORADO COUNTY COUNSEL  
2010 MAY -5 PM 3:37

**RISK MANAGEMENT:** (All contracts and MOU's except boilerplate grant funding agreements)

Approved:  Disapproved:  Date: 5/19/10 By: *[Signature]*

Approved:  Disapproved:  Date: \_\_\_\_\_ By: \_\_\_\_\_

EL DORADO COUNTY COUNSEL  
2010 MAY 19 AM 9:06

**OTHER APPROVAL:** (Specify department(s) participating or directly affected by this contract).

Departments: \_\_\_\_\_

Approved:  Disapproved:  Date: \_\_\_\_\_ By: \_\_\_\_\_

Approved:  Disapproved:  Date: \_\_\_\_\_ By: \_\_\_\_\_

**FUNDING AGREEMENT NO. 001-DMV-10/11-BOS**  
**WITH EL DORADO COUNTY DEPARTMENT OF TRANSPORTATION**

---

**This Agreement No. 001-DMV-10/11-BOS** made and entered by and between the **EL DORADO COUNTY AIR QUALITY MANAGEMENT DISTRICT**, a county air pollution control district formed pursuant to California Health and Safety Code section 40100, et seq. (hereinafter referred to as "AQMD"); and El Dorado County Department of Transportation, (hereinafter referred to as "CONTRACTOR");

**WITNESSETH:**

**WHEREAS**, the California Clean Air Act requires local air pollution control districts to reduce emissions from motor vehicles; and

**WHEREAS**, AB 2766, codified in California Health and Safety Code section 44220, et seq., authorizes districts to impose a fee of up to four dollars upon certain registered motor vehicles within the AQMD, and the Governing Board of the AQMD has imposed said fee; and

**WHEREAS**, said legislation requires the AQMD to use said funds for activities related to reducing air pollution from motor vehicles and for related planning, monitoring, enforcement, and technical studies necessary for the implementation of the California Clean Air Act of 1988; and

**WHEREAS**, CONTRACTOR has proposed a Project that meets the eligibility criteria of the AQMD and that has been approved by AQMD for funding; and

**WHEREAS**, CONTRACTOR represents that it is willing and able to perform the activities set forth herein.

**NOW, THEREFORE**, AQMD and CONTRACTOR mutually agree as follows:

## **1. PROJECT**

CONTRACTOR shall perform all activities and work necessary to complete the Replacement of a Street Sweeper with a Cleaner Waterless/dustless Broom Street Sweeper Project (hereinafter referred to as "Project"); set forth in the fully described "Proposal" attached hereto as Exhibit "A" and incorporated herein by this reference. CONTRACTOR agrees to furnish all labor, materials, equipment, licenses, permits, fees, and other incidentals necessary to perform and complete, per schedule, in a professional manner, the services described herein. CONTRACTOR represents that CONTRACTOR has the expertise necessary to adequately perform the Project specified in said Proposal.

In the event of any conflict between or among the terms and conditions of this Agreement, the Proposal incorporated herein, and the documents referred to and incorporated herein, such conflict shall be resolved by giving precedence in the following order of priority:

1. To the text of this Agreement;
2. Proposal to this Agreement; and
3. To the "Motor Vehicle Emission Reduction Projects Request for Proposals" (RFP) released to Interested Parties by the AQMD and dated 2010-2011.

## **2. PERIOD OF PERFORMANCE/TIMETABLE**

CONTRACTOR shall commence performance of work and produce all work products in accordance with the Work Statement and deadlines for performance identified in the Proposal of this Agreement, unless this Agreement is terminated sooner as provided for elsewhere in this Agreement.

If requested by the AQMD, CONTRACTOR shall submit regular progress reports, at intervals determined by the AQMD, detailing the work performed during the current reporting period; work planned for the next reporting period; problems identified, solved, and/or unresolved; and the percentage of each task completed. CONTRACTOR shall provide AQMD with a comprehensive final written report prior to the end of Agreement term. Said final report shall be complete and shall document the work performed under this Agreement.

### **3. TERM**

The term of this Agreement shall be for the period of July 1, 2010 through June 30, 2011 unless terminated earlier in accordance with Article 7, Termination.

### **4. COMPENSATION**

AQMD will pay the CONTRACTOR the sum of ONE HUNDRED NINETY THOUSAND FIVE HUNDRED AND TWENTY DOLLARS AND NO CENTS (\$190,520.00) as follows:

CONTRACTOR shall obtain through other sources sufficient additional monies to fund the total cost of the Project as outlined in the Proposal. Satisfactory written evidence of such funding commitments shall be provided to AQMD prior to the release by AQMD of any funds under this Agreement. In the event funding from other sources for the total cost of the Project is not received by CONTRACTOR, AQMD reserves the right to terminate or renegotiate this Agreement. In accordance with Section 44233 of the California Health and Safety Code, CONTRACTOR agrees to limit expenditure of funds for the purpose of administration to not more than five percent of the monies distributed to CONTRACTOR. The AQMD is not obligated to pay CONTRACTOR for administrative costs exceeding five percent of the actual total cost of the Project.

The total obligation of the AQMD under this Agreement shall not exceed ONE HUNDRED NINETY THOUSAND FIVE HUNDRED AND TWENTY DOLLARS AND NO CENTS (\$190,520.00).

A. **PAYMENTS:** Advance payments shall not be permitted. Payments will be permitted only at which time an equivalent service has been completed. The AQMD shall reimburse CONTRACTOR quarterly, in arrears, after receipt and verification submitted to El Dorado County Air Quality Management District, Attention: Marcella McTaggart. Payment shall be made to CONTRACTOR by the AQMD upon submission and evaluation of the CONTRACTOR'S invoice of claim. Said invoice of claim shall set forth the work completed pursuant to this Agreement.

Upon receipt of proper documentation, and verification that CONTRACTOR has satisfactorily completed the work for which compensation is sought and that the work is in accordance with the Exhibit Summary Sheet attached hereto, AQMD will issue payment to CONTRACTOR within forty five (45) calendar days of verification.

The amount to be paid to CONTRACTOR under this Agreement includes all sales and use taxes incurred pursuant to this Agreement, if any, including any such taxes due on equipment purchased by the CONTRACTOR. The CONTRACTOR shall not receive additional compensation for reimbursement of such taxes and shall not decrease work to compensate therefore.

Concurrently with the submission of any claim for payment, CONTRACTOR shall certify (through copies of invoices issued, checks, receipts, and the like) that complete payment has been made to any and all subcontractors as provided.

It is understood that all expenses incidental to CONTRACTOR'S performance of services under this Agreement shall be borne exclusively by CONTRACTOR.

In no event shall compensation paid by the AQMD to the CONTRACTOR for the performance of all services and activities under this Agreement exceed the amount set forth in paragraph 4 above.

**B. Surplus Funds:** Any compensation under this agreement, which is not expended by CONTRACTOR pursuant to the terms and conditions of this Agreement by the Project completion date, shall automatically revert to the AQMD. Only expenditures incurred by the CONTRACTOR in the direct performance of this Agreement will be reimbursed by the AQMD. Allowable expenditures under this Agreement are specifically established and included in the Proposal.

**C. Closeout Period:** All final claims shall be submitted by CONTRACTOR within sixty (60) days following the final month of activities for which payment is claimed. No action will be taken by AQMD on claims submitted beyond the 60-day closeout period.

## **5. NON-ALLOCATION OF FUNDS**

The terms of this Agreement and the services to be provided thereunder are contingent on the approval of funds by the appropriating government agency. Should sufficient funds not be allocated, the services provided may be modified or this Agreement terminated at any time by giving the CONTRACTOR thirty (30) days prior written notice.

## **6. INDEPENDENT CONTRACTOR LIABILITY**

CONTRACTOR is, and shall be at all times, deemed independent and shall be wholly responsible for the acts of CONTRACTOR'S employees, associates, and subcontractors, in connection with the installation, operation, use and maintenance of the Project.

## 7. TERMINATION

A. **Breach of Agreement:** AQMD may immediately suspend or terminate this Agreement, in whole or in part, where in the determination of the AQMD there is:

1. An illegal or improper use of funds;
2. A failure to comply with any term of this Agreement;
3. A substantially incorrect or incomplete report submitted to the AQMD; or
4. Improperly performed services.

In no event shall any payment by the AQMD constitute a waiver by the AQMD of any breach of this Agreement or any default, which may then exist on the part of the CONTRACTOR. Neither shall such payment impair or prejudice any remedy available to the AQMD with respect to the breach or default. The AQMD shall have the right to demand of the CONTRACTOR the repayment to the AQMD of any funds disbursed to the CONTRACTOR under this Agreement which in the judgment of the AQMD were not expended in accordance with the terms of this Agreement. The CONTRACTOR shall promptly refund any such funds upon demand.

In addition to immediate suspension or termination, AQMD may impose any other remedies available at law, in equity, or otherwise specified in this Agreement.

B. **Without Cause:** Either party may terminate this Agreement at any time upon giving the other party at least thirty (30) days advance, written notice of intention to terminate. In such case,

the AQMD shall, subject to paragraph 4, pay its pro rata share of the reasonable value of all services satisfactorily rendered and actual, reasonable costs incurred up to the time of the termination. Upon such termination, all the work product produced by CONTRACTOR shall be promptly delivered to the AQMD.

## **8. CHANGES TO AGREEMENT**

This Agreement may be amended by mutual consent of the parties hereto. Said amendments shall become effective only when in writing and fully executed by duly authorized officers of the parties hereto.

## **9. INDEMNIFICATION**

CONTRACTOR shall defend, indemnify, and hold the AQMD harmless against and from any and all claims, suits, losses, damages and liability for damages of every name, kind and description, including attorneys fees and costs incurred, brought for, or on account of, injuries to or death of any person, including but not limited to workers, AQMD employees, and the public, or damage to property, or any economic or consequential losses, which are claimed to or in any way arise out of or are connected with the CONTRACTOR'S activities and work necessary to complete the Project unless such claim, loss, damage, injury or death is the result of the sole or active negligence of the AQMD. This duty of CONTRACTOR to indemnify and save AQMD harmless includes the duties to defend set forth in California Civil Code, Section 2778.

AQMD shall indemnify CONTRACTOR against and hold it harmless from any loss, damage, and liability for damages, including attorney fees and other costs of defense incurred by CONTRACTOR, whether for damage to or loss of property, or injury to or death of CONTRACTOR'S officer's, agents, or employees which shall in any way arise out of or be



connected with AQMD's performance of its obligations hereunder, unless such damage, loss, injury, or death shall be caused by the sole or active by negligence of the CONTRACTOR.

#### **10. AUDITS AND INSPECTIONS**

CONTRACTOR shall at any time during regular business hours, and as often as AQMD may deem necessary, make available to AQMD for examination all of CONTRACTOR'S records and data with respect to the matters covered by this Agreement. CONTRACTOR shall, and upon request by AQMD, permit AQMD to audit and inspect all of such records and data necessary to ensure CONTRACTOR'S compliance with the terms of this Agreement. CONTRACTOR shall be subject to an audit by AQMD or its authorized representative to determine if the revenues received by CONTRACTOR were spent for the reduction of pollution as provided in AB 2766 and to determine whether said funds were utilized as provided by law and this Agreement. If, after audit, AQMD makes a determination that funds provided CONTRACTOR pursuant to this Agreement were not spent in conformance with this Agreement, or AB 2766 or any other applicable provisions of law, CONTRACTOR agrees to immediately reimburse AQMD all funds determined to have been expended not in conformance with said provisions.

CONTRACTOR shall retain all records and data for activities performed under this Agreement for at least three (3) years from the date of final payment under this Agreement or until all state and federal audits are completed for that fiscal year, whichever is later.

Because this Agreement exceeds Ten Thousand Dollars (\$10,000), CONTRACTOR shall be subject to the examination and audit of the State Auditor for a period of three (3) years after final payment under Agreement (Government Code Section 10532).

**11. NOTICES TO PARTIES**

All notices to be given by the parties hereto shall be in writing and served by depositing same in the United States Post Office, postage prepaid and return receipt requested. Notices shall be in duplicate and addressed as follows:

**CONTRACTOR**

El Dorado County Department of Transportation  
2850 Fairlane Court  
Placerville, CA 95667  
Attn : James Ware  
Director of Transportation

**AQMD**

El Dorado County  
Air Quality Management District  
2850 Fairlane Court  
Placerville, CA 95667  
Attn: Marcella McTaggart,  
Air Pollution Control Officer

**12. TIME IS OF THE ESSENCE**

It is understood that for CONTRACTOR'S performance under this Agreement, time is of the essence. The parties reasonably anticipate that CONTRACTOR will, to the reasonable satisfaction of the AQMD, complete all activities provided herein within the time schedule outlined in the Proposals to this Agreement.

**13. COMPLIANCE WITH APPLICABLE LAWS**

CONTRACTOR will comply with all federal, State, and local laws and ordinances which are or may be applicable to the PROJECT to be undertaken by the CONTRACTOR including but not limited to California Health and Safety Code sections 44220 et seq, all Air Resources Board and AQMD criteria there under, prevailing wage and work day definitions where applicable, contracting license requirements and permits.

**14. NO THIRD-PARTY BENEFICIARIES**

Nothing in this Agreement shall be construed to create any rights of any kind or nature in any other party not a named party to this Agreement.

**15. VENUE**

Any dispute resolution action arising out of this Agreement, including but not limited to litigation, mediation, or arbitration, shall be brought in El Dorado County, California, and shall be resolved in accordance with the laws of the State of California.

**16. ENTIRE AGREEMENT**

This document and the documents referred to herein or exhibits hereto are the entire Agreement between the parties and they incorporate or supersede all prior written or oral Agreements or understandings.

**17. AGREEMENT ADMINISTRATOR**

The AQMD Officer or employee with responsibility for administration of this Agreement is Marcella McTaggart, Air Pollution Control Officer or her successor. The CONTRACTOR Officer or employee with responsibility for administration of this Agreement is James Ware, Director of Transportation, or his successor.

**18. AUTHORIZED SIGNATURES**

The parties to this Agreement represent that the undersigned individuals executing this Agreement on their respective behalf are fully authorized to do so by law or other appropriate instrument and to bind upon said parties to the obligations set forth herein.

**19. PARTIAL INVALIDITY**

If any provision of this Agreement is held by a court of competent jurisdiction to be invalid, void, or unenforceable, the remaining provisions will continue in full force and effect without being impaired or invalidated in any way.

**AGREEMENT ADMINISTRATOR CONCURRENCE:**

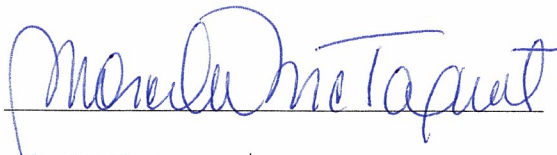
By:  Dated: 05-24-2010

**Marcella McTaggart  
Air Pollution Control Officer  
El Dorado County Air Quality Management District**

**REQUESTING DEPARTMENT CONCURRENCE:**

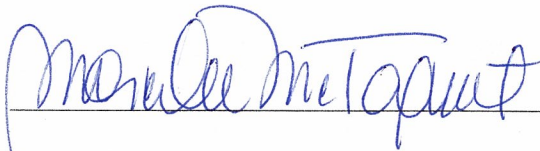
By:  Dated: 05-24-2010

**Marcella McTaggart  
Air Pollution Control Officer  
El Dorado County Air Quality Management District**

IN WITNESS WHEREOF, the parties hereto have caused this Agreement to be executed as of the day and year first herein below written.

**CONTRACTOR**

**AQMD  
EL DORADO COUNTY  
AIR QUALITY MANAGEMENT DISTRICT**

Date: 5/24/10

Date: \_\_\_\_\_

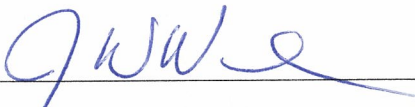
By: 

By: \_\_\_\_\_

**James Ware  
Director of Transportation**

**Chair  
Norma Santiago**

**Attest:  
Suzanne Allen de Sanchez,  
Clerk of the Board**

Date: \_\_\_\_\_

By: \_\_\_\_\_

## Cleaner Street Sweeper Purchases

**Air District Name:** El Dorado County APCD

**Local Government Name:** Not Applicable

**Project Name:** DOT Sweeper Alt.

Description:  
(Issues/Comments)

Implementing Agency: EDCDOT

Private Agency: No

<b>MVFees Funding:</b>	\$238,150	<b>Main Engine Fuel:</b>	1,320 gal/yr
<b>MSRC Funding:</b>	\$0	<b>Auxiliary Engine Fuel:</b>	2,640 gal/yr
<b>Moyer Funding:</b>	\$0	<b>Miles Swept:</b>	4,200 miles/yr
<b>CMAQ Funding:</b>	\$0		
<b>Other CoFunding</b>	\$59,368		
<b>Capital Recovery Factor:</b>	0.22		
<b>Project Analysis Period:</b>	5 years		

→ corrected to 5 yrs (surplus emissions)

**EMISSION FACTORS:**

	Baseline Vehicle Emission Factors		Cleaner Vehicle Emission Factors	
	Main Engine	Auxiliary Engine	Main Engine	Auxiliary Engine
<b>ROG :</b>	0.00	0.99 g/bhp-hr	0.00	0.10 g/bhp-hr
<b>NOx :</b>	4.25	6.90	0.22	2.89
<b>PM10 :</b>	0.06	0.69	0.01	0.20

**EMISSION REDUCTIONS:**

	Pounds per Year	Kilograms per Day	
<b>ROG:</b>	96	0.12	PM10 Reductions from Sweeping ONLY:
<b>NOx:</b>	648	0.81	
<b>PM10:</b>	265	0.33	
<b>Total:</b>	<b>1,009</b>	<b>1.26</b>	210 lbs/yr

**COST-EFFECTIVENESS OF:**

<b>Motor Vehicle Fees plus Moyer Funds:</b>	\$51.52	per pound	\$103,044	per ton
<b>CMAQ Funds:</b>	\$0.00	per pound	\$0	per ton
<b>All Funding Sources:</b>	\$64.37	per pound	\$128,732	per ton

# Cleaner Street Sweeper Purchases

**Air District Name:** El Dorado County APCD

**Local Government Name:** Not Applicable

**Project Name:** DOT Street Sweeper

Description:  
(Issues/Comments)

Implementing Agency: EDC DOT

Private Agency: No

<b>MVFees Funding:</b>	\$267,919	<b>Main Engine Fuel:</b>	1,320 gal/yr
<b>MSRC Funding:</b>	\$0	<b>Auxiliary Engine Fuel:</b>	2,640 gal/yr
<b>Moyer Funding:</b>	\$0	<b>Miles Swept:</b>	4,200 miles/yr
<b>CMAQ Funding:</b>	\$0		
<b>Other CoFunding</b>	\$29,769		

**Capital Recovery Factor:** 0.22

**Project Analysis Period:** 5 years

**EMISSION FACTORS:**

	<b>Baseline Vehicle Emission Factors</b>		<b>Cleaner Vehicle Emission Factors</b>	
	<i>Main Engine</i>	<i>Auxiliary Engine</i>	<i>Main Engine</i>	<i>Auxiliary Engine</i>
<b>ROG :</b>	0.00	0.99 g/bhp-hr	0.00	0.10 g/bhp-hr
<b>NOx :</b>	4.25	6.90	0.22	2.89
<b>PM10 :</b>	0.06	0.69	0.01	0.20

**EMISSION REDUCTIONS:**

	<b>Pounds per Year</b>	<b>Kilograms per Day</b>	
<b>ROG:</b>	96	0.12	PM10 Reductions from Sweeping ONLY:
<b>NOx:</b>	648	0.81	
<b>PM10:</b>	265	0.33	
<b>Total:</b>	<u>1,009</u>	<u>1.26</u>	

**COST-EFFECTIVENESS OF:**

<b>Motor Vehicle Fees plus Moyer Funds:</b>	\$57.96	per pound	\$115,925	per ton
<b>CMAQ Funds:</b>	\$0.00	per pound	\$0	per ton
<b>All Funding Sources:</b>	\$64.40	per pound	\$128,805	per ton

## Emission Credits

Dennis P Milligin o Marcella McTaggart

04/29/2010 03:05 PM

Marcella

Upon reviewing the ARB Public Fleet Rule we have determined that DOT has 5 years of emission credits for the 2001 Schwarze street sweeper because of installed retrofits and early compliance.

Dennis Milligin  
Fleet Services Manager  
El Dorado County  
Department of Transportation  
530 642-4900





**MAINTENANCE DIVISION**  
2441 Headington Road  
Placerville CA 95667  
Phone: (530) 642-4909  
Fax: (530) 642-9238

**JAMES W. WARE, P.E.**  
Director of Transportation  
  
Internet Web Site:  
<http://co.el-dorado.ca.us/dot>

**MAIN OFFICE**  
2850 Fairlane Court  
Placerville CA 95667  
Phone: (530) 621-5900  
Fax: (530) 626-0387

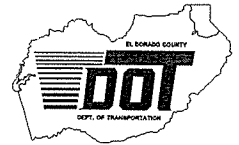

March 26, 2010

El Dorado County AQMD  
2850 Fairlane Court  
Placerville, CA 95667  
**Attn: Kerri Williams, Time Critical**

RE: FY 10/11 Motor Vehicle Emission Reductions (AB2766 DMV) Funding Proposal

Dear Ms. Williams,

Attached is a project proposal from the El Dorado County Department of Transportation (DOT) for FY 2010/11 Motor Vehicle Emission Reductions (AB2766 DMV Surcharge Fees) funding to purchase a new **waterless/dustless broom street sweeper** to replace an existing 2001 Schwarze regenerative air street sweeper.

We are requesting grant funding of **\$267,919**, which is ninety percent of the estimated total project cost, based on a vendor quote for a new 2010 Elgin Eagle UD3300 dual steer waterless sweeper. This is the same make/model as the sweeper that DOT purchased in 2008 with FY 2008/09 AB2766 DMV funding.

DOT is currently in the FY 2010/11 budget process and is committing local funding (Road Fund) **up to 20 percent of the total project cost (\$59,538)** in the Maintenance Division's FY 2010/11 budget for matching funds for the AB2766 grant funding. However, with the County's current budgetary constraints and DOT's Maintenance Division's backlog of prioritized projects, it is strongly desired to have this project funded at the 90 percent level.

Thank you for your consideration of this motor vehicle emissions reductions project. If you have any questions, please contact Dennis Milligin at 642-4900 or e-mail at [dennis.milligin@edcgov.us](mailto:dennis.milligin@edcgov.us).

Sincerely,

  
James W. Ware, P.E.  
Director of Transportation

JWW:an

c: Dennis Milligin, Fleet Services Manager  
Anne Novotny, Senior Planner

RECEIVED  
MAR 26 2010  
AQMD

**EXHIBIT SUMMARY SHEET (COVER)**

Applicant: El Dorado County Department of Transportation  
 Contact Person: Dennis Milligin, Fleet Services Manager  
 Address: 2441 Headington Road, Placerville, CA 95667  
 Telephone #: (530) 642-4900 Fax #: (530) 642-9238 E-mail: [dennis.milligin@edcgov.us](mailto:dennis.milligin@edcgov.us)

Project Title: **On-Road Cleaner Vehicle Replacement Purchase – Waterless Broom Street Sweeper**

Project Budget (As Proposed)	AB 2766 Funds	\$ Matching Funds (10%)	In-Kind Match	Total Project Costs
Materials	\$ 267,919	\$ 29,769	\$	\$ 297,688
Personnel	\$	\$	\$	\$
<b>TOTAL</b>	<b>\$ 267,919</b>	<b>\$ 29,769</b>	<b>\$</b>	<b>\$ 297,688</b>

Alternative Project Budget 1	AB 2766 Funds	\$ Matching Funds (15%)	In-Kind Match	Total Project Costs
Materials	\$ 253,035	\$ 44,653	\$	\$ 297,688
Personnel	\$	\$	\$	\$
<b>TOTAL</b>	<b>\$ 253,035</b>	<b>\$ 44,653</b>	<b>\$</b>	<b>\$ 297,688</b>

Alternative Project Budget 2	AB 2766 Funds	\$ Matching Funds (20%)	In-Kind Match	Total Project Costs
Materials	\$ 238,150	\$ 59,538	\$	\$ 297,688
Personnel	\$	\$	\$	\$
<b>TOTAL</b>	<b>\$ 238,150</b>	<b>\$ 59,538</b>	<b>\$</b>	<b>\$ 297,688</b>

Estimated Emission Reductions/Cost-Effectiveness	As Proposed	Alternate 1 Funding Level	Alternate 2 Funding Level
Useful Life of Project (years)	10	10	10
Total Lifetime Emissions Reduced (lbs. of NOx, PM-10)	8,230	8,230	8,230
Annualized Cost-Effectiveness (total project costs)*	\$ 37.99/lb.	\$ 37.99/lb.	\$ 37.99/lb.
Annualized Cost-Effectiveness (AQMD Funded project costs)*	\$ 34.19/lb.	\$ 32.29/lb.	\$ 30.39/lb.

\*: See Appendix 3 for instructions

**Brief Project Description:** Purchase a new on-road, heavy-duty diesel waterless/dustless broom street sweeper to replace an existing 2001 diesel Schwarze regenerative air street sweeper.

## ***REQUEST FOR PROPOSAL CONTENTS CHECKLIST***

Applicant: **El Dorado County Department of Transportation**

---

**Please complete and attach this checklist with your application.**

- Exhibit Summary Sheet (Cover) – page 1
  - Request for Proposal Contents Checklist (Second Page) – page 2
  - Authorization Letter/Resolution – page 10
  - Project Description – page 3
  - Project Organization/Background – page 4
  - Emission Benefits/Cost Effectiveness – pages 5, 11 - 13
  - Work Statement – page 6
  - Funding Request/Cost Breakdown – page 7
  - Matching Funds – pages 7 & 10
  - Schedule of Deliveries/Self-Monitoring Program – page 8
    - Attachment A – Resolution No. 273-2008 adopted 10/07/08 – page 9
    - Attachment B – Matching Funds Letter – page 10
    - Attachment C – Emissions Benefits/Cost-Effectiveness (3 funding levels) – pages 11 - 13
    - Attachment D – Vendor Quote – pages 14 - 17
    - Attachment E – Elgin Waterless Eagle brochure – pages 18 – 23
    - Attachment F – UD3300 Waterless Eagle chassis spec sheet – pages 24 – 25
    - Attachment G – Waterless Eagle sweeper spec sheet – page 26
  - Local TPA Review (When Applicable) – page N/A
  - 2 Copies of Proposal
-

**PROJECT DESCRIPTION**

*Identify the objective(s) of the proposal and describe the scope of work of the proposed project.*

The County DOT is requesting this funding to purchase a new on-road, heavy-duty diesel waterless/dustless broom street sweeper to replace an existing 2001 diesel Schwarze (Model A8000) regenerative air street sweeper. The existing sweeper is used daily on County maintained paved roads throughout the Tahoe Basin area. Average annual usage hours is 825, annual vehicle miles swept is 4,200 (5.1 miles per hour), and annual fuel consumption is about 4,000 gallons. The current main and auxiliary engine specifications are as follows:

<b>Main Engine (front, on-road)</b>	<b>Auxiliary Engine (rear, portable, non-road)</b>
Equipment Make: Sterling (Chassis) Model: N/A Year: 2001 GVWR: 32,000 lbs. Engine Mfg: Cummins Engine Model: ISB225 Engine Model Yr: 2001 Horsepower: 225 Displacement: 5.9L Total Hours: 9,011 (as of 3/3/2010) Annual Hours: 928 Annual Fuel Consumption: 1,320 gallons Annual Miles: 4,200 Engine Tier Level: 1 Engine Family/Serial #: EF – 1CEXHO359BAP	Equipment Make: Schwarze Model: A8000 Year: 2001 GVWR: N/A Engine Mfg: John Deere Engine Model: 4045T Engine Model Yr: 2001 Horsepower: 115 Displacement: 4.5L Total Hours: 7,700 (as of 3/3/2010) Annual Hours: 825 Annual Fuel Consumption: 2,640 gallons  Engine Tier Level: 1 Engine Family/Serial #: YJDXL06-8014

The proposed replacement waterless sweeper engine specifications are as follows:

<b>Main Engine (front, on-road)</b>	<b>Auxiliary Engine (rear, portable)</b>
Equipment Make: Elgin Eagle Model: UD3300 Dual Steer (Chassis) Year: 2010 GVWR: 32,900 Engine Mfg: Hino Engine Model: MD230 Engine Model Yr: 2010 Horsepower: 230 Displacement: 7.7L Engine Emission Level: 2007 emissions Engine Family/Serial #: N/A	Equipment Make: N/A Model: N/A Year: N/A GVWR: N/A Engine Mfg: John Deere Engine Model: 4045 - 4 cylinder, diesel Engine Model Yr: 2010 Horsepower: 99 Displacement: 4.5L Engine Tier Level: 3 Engine Family/Serial #: N/A

***See Attachments D – G for vendor quote, brochure and detailed specifications for the proposed Elgin Eagle UD3300 waterless street sweeper.***

The scope of the project would include: demonstrations of comparable waterless/dustless broom street sweepers, preparing the bid specifications, releasing the bid document, evaluating the bids and selecting the vendor, preparing/awarding the contract, coordinating the procurement process, inspecting/accepting the new equipment, preparing the new vehicle for service, and surplusing the old vehicle (ID 71-05) which will be sent to auction in Modesto for sale outside El Dorado County.

## **PROJECT ORGANIZATION/BACKGROUND**

*Provide a very brief description (one page or less: no resumes) of your organization, its need for AB2766 DMV Surcharge Funding for the proposal and its qualifications to successfully carry out the proposed project.*

The mission of the El Dorado County Department of Transportation is to provide a safe, congestion free road and highway system that is responsive to the needs of the County's citizens, and is environmentally sensitive. The County DOT Maintenance and Operations Division is responsible for the maintenance of 1,070 miles of roadway in El Dorado County. The maintenance program includes asphalt patching and paving, roadside brushing and tree trimming, crack sealing, ditch cleaning, roadway sweeping, storm drain and culvert cleaning, bridge maintenance and the roadside vegetation control (herbicide) program. The Maintenance Unit also operates the equipment maintenance facilities that maintain the department's heavy equipment and vehicles. In addition, it conducts the snow removal program and the surface treatment (overlay and chip seal) program. This division is also responsible for the Traffic Unit, which provides installation and maintenance of roadway signs, traffic signals and roadway striping.

Maintaining safe roads involves keeping the roads clear of trash and debris. Routine roadway sweeping is critical to accomplishing this goal. The current sweeper that is used daily on the County maintained paved roads throughout the Tahoe Basin area is a 2001 Schwarze regenerative air sweeper. Replacement of this sweeper with a new, waterless/dustless broom sweeper uses cleaner technology that is less polluting and more environmental sensitive.

*Please indicate if your agency has successfully completed a similar project.*

The EDCDOT Maintenance and Operations Division currently maintains 156 pieces in its fleet of rolling stock. On an on-going, as needed basis, the Maintenance Unit has successfully implemented numerous engine repowers and exhaust retrofits with cleaner technology. In a proactive effort to be in early compliance with the California Air Resources Board (CARB) on-road and portable diesel fleet regulations, the County DOT applied in February 2007 for \$792,322 of \$25 Million one-time funding for the purchase of low-polluting construction equipment from CARB. The County DOT was awarded \$823,766 in June 2007 and successfully implemented 23 repower/retrofit off-road vehicles by June 2009.

In March 2008, DOT applied for AB2766 funding for a new waterless street sweeper and in July 2008 was awarded \$203,236 (75% of the total project cost). In February 2009, the Board awarded the bid for the purchase of the new sweeper and in May 2009, the new 2008 Elgin Eagle UD3300 was delivered and implemented. This similar project was successfully completed within the funding contract term (7/1/2008 - 6/30/2009).

*If sub-contractors are to be used on the project, please identify and state their qualifications, or if sub-contractors have not yet been identified, state the specific qualifications that must be met.*

Not applicable.

## **EMISSION BENEFITS/COST EFFECTIVENESS**

The Emissions Benefits/Cost Effectiveness of the proposed project were determined by using the California Air Resources Board (CARB) Methods to Find the Cost-Effectiveness of Funding Air Quality Projects, May 2005, pages 11 – 15, Cleaner Street Sweeper Purchases and the Emissions Factor Tables updated February 2010 by CARB. The calculations were done using the automated Microsoft Access database program (Generic Methods Program) available from the California Air Resources Board website <http://www.arb.ca.gov/planning/tsaq/eval/eval.htm> was used to calculate the cost-effectiveness for this proposal. See Attachment C on pages 11-13 for the calculations of each of the three proposed funding scenarios shown on page 1.

### **Inputs to Calculate Cost Effectiveness:**

<b>Inputs</b>	<b>Default</b>	<b>Units</b>	<b>Comments</b>
Funding Dollars ( <b>Funding @ 90%</b> )	267,919	dollars	
Funding Dollars ( <b>Funding @ 85%</b> )	253,035	dollars	
Funding Dollars ( <b>Funding @ 80%</b> )	238,150	dollars	
Effectiveness Period ( <b>Life</b> )	10	years	Default for heavy-duty trucks
Annual Fuel Consumption (Main Engine)	1,320	gallons	Based on 33% of actual fuel consumption for Sweeper ID 71-05 for 12-month period 01/01/2009 – 12/31/2009
Annual Fuel Consumption (Auxiliary Engine)	2,640	gallons	Based on 67% of actual fuel consumption for Sweeper ID 71-05 for 12-month period 01/01/2009 – 12/31/2009
Annual Vehicle Miles Swept	4,200	annual miles	Based on actual mileage of Sweeper ID 71-05 for 12-month period 01/01/2009 – 12/31/2009

### **Emission Factor (EF) Inputs:**

<b>MAIN ENGINE (ON-ROAD)</b>				
<b>Factor</b>	<b>EF Before</b>	<b>Units (grams)</b>	<b>EF After</b>	<b>Units(grams)</b>
ROG	N/A*	g/mi	N/A*	g/mi
NOx	2.79	g/mi	0.40	g/mi
PM10	0.024	g/mi	0.018	g/mi
<b>AUXILIARY ENGINE (NON-ROAD)</b>				
<b>Factor</b>	<b>EF Before</b>	<b>Units (grams)</b>	<b>EF After</b>	<b>Units (grams)</b>
ROG	0.99	g/mi	0.10	g/mi
NOx	6.90	g/mi	2.89	g/mi
PM10	0.69	g/mi	0.20	g/mi

Source: California Air Resources Board, Methods to Find the Cost-Effectiveness of Funding Air Quality Projects, Emission Factors Tables, February 2010, Table 5 (Main Engine) and Table 6 (Auxiliary Engine)

## WORK STATEMENT

*Describe separately each phase of the work to be performed.*

- 1) Evaluation of various makes/models of new waterless/dustless broom street sweepers
- 2) Preparation of the bid specifications and releasing the bid
- 3) Selection of vendor and award contract
- 4) Procure equipment
- 5) Acceptance of equipment delivery and preparation of the new vehicle for service
- 6) Surplusing the old vehicle (ID 71-05) for sale outside El Dorado County.

*List tasks within each phase of work and describe as necessary.*

- 1) Schedule demos of various makes/models of new waterless broom street sweepers
- 2) Prepare the bid specs and release the bid
- 3) Evaluate bid proposals, select vendor, prepare contract and obtain Board approval to award contract to selected vendor
- 4) Coordinate procurement process with County Purchasing Department
- 5) Inspect and accept delivered equipment and prepare vehicle for service
- 6) Surplus old vehicle (ID 71-05) to Auction in Modesto

*State the sequence of work activities, including a starting date, this date should not be sooner than the contract execution date between the District and Grantee, and a completion date within one year of executed contract.*

	<b>Fiscal Year 2010/11</b>
1. Demo waterless broom street sweepers.....	1 <sup>st</sup> Quarter (Jul-Sep 2010)
2. Prepare bid specifications.....	1 <sup>st</sup> Quarter (Jul-Sep 2010)
3. Release bid document.....	1 <sup>st</sup> Quarter (Sep 2010)
4. Evaluate bids and select vendor .....	2 <sup>nd</sup> Quarter (Oct-Nov 2010)
5. Prepare/award contract.....	2 <sup>nd</sup> Quarter (Nov-Dec 2010)
6. Coordinate procurement process.....	3 <sup>rd</sup> Quarter (Jan-Feb 2011)
7. Inspect/accept new vehicle.....	3 <sup>rd</sup> Quarter (Feb-Mar 2011)
8. Prepare new vehicle for on-road service .....	4 <sup>th</sup> Quarter (Apr-May 2011)
9. Implement new vehicle .....	4 <sup>th</sup> Quarter (June 2011)
10. Surplus old vehicle (ID 71-05).....	4 <sup>th</sup> Quarter (June 2011)

*Include all relevant information regarding the technology involved, and the parties directly connected with the project.*

The technology used is waterless/dustless sweeping. The project involves the El Dorado County DOT and the selected vendor (to be determined)

*All grant recipients must provide some type of public acknowledgment that their project was funded by the District utilizing AB2766 DMV Surcharge Funds. How will this be accomplished for this project (e.g. logo/placard on equipment, include acknowledgment in a public education address or pamphlets, etc.)?*

A placard acknowledging that this project was partially funded with AB2766 DMV Surcharge Funds will be displayed on the vehicle. In addition, acknowledgments will be included in press releases.

## **FUNDING REQUEST/COST BREAKDOWN/MATCHING FUNDS**

Briefly describe the proposal to be funded. Include the amount of money requested from the AB2766 DMV Surcharge fund. All applicants are also strongly encouraged to submit alternative funding levels in their proposals. Include total project costs, including, but not limited to the following: Estimate cost by task and identify source of funding for each task; itemized list of equipment and the proportion of the cost of each piece of equipment to be paid with AB2766 DMV Surcharge funds.

This proposal is requesting **\$ 267,919** which is 90% of the estimated cost (including El Dorado County sales tax) to purchase a new waterless broom street sweeper.

The following table details the total estimated project costs, broken down by task and fiscal year. The second table identifies the revenue sources by fiscal year.

### **Cost Estimates by Task (as of 03/29/2010)**

<b>Task</b>	<b>FY 10/11</b>	<b>FY 11/12</b>	<b>Total</b>
On-Road Heavy-Duty Vehicle Replacement	\$ 275,000	\$	\$ 275,000
Sales Tax (8.25% in El Dorado County)	\$ 22,688		\$ 22,688
<b>Total Estimated Project Costs</b>	<b>\$ 297,688</b>	<b>\$</b>	<b>\$ 297,688</b>

### **Revenue Source (as of 03/29/2010)**

	<b>FY 10/11</b>	<b>FY 11/12</b>	<b>Total</b>
AB2766 DMV Surcharge funds requested	\$ 267,919	\$	\$ 267,919
Matching Funds (Source: Road Fund)	\$ 29,769	\$	\$ 29,769
Other Funds	\$	\$	\$
<b>Total Revenue</b>	<b>\$ 297,688</b>	<b>\$</b>	<b>\$ 297,688</b>

### **Matching Funds**

Clearly indicate if the matching funds are monetary or in-kind (non-dollar) contributions along with their source. Provide proof (letter of commitment, reso, CIP Project Summary) that the matching funds are currently available from each funding source.

The matching funds are monetary. DOT is committing local Road Fund monies up to 20 percent of the total project cost (\$59,538) in the Maintenance Divisions's FY 2010/11 budget (see Attachment B on page 10).



## **SCHEDULE OF DELIVERABLES/SELF-MONITORING PROGRAM**

*Provide a list of all work products or deliverable items and their anticipated dates of delivery. The schedule must not extend beyond one year of the date of the executed contract*

<b>Work Products/Deliverables</b>	<b>Delivery Date</b>
	<b><i>Fiscal Year 2010/11</i></b>
1. Demo waterless broom street sweepers .....	1 <sup>st</sup> Quarter (Jul-Sep 2010)
2. Prepare bid specifications .....	1 <sup>st</sup> Quarter (Jul-Sep 2010)
3. Release bid document .....	1 <sup>st</sup> Quarter (Sep 2010)
4. Evaluate bids and select vendor .....	2 <sup>nd</sup> Quarter (Oct-Nov 2010)
5. Prepare/award contract .....	2 <sup>nd</sup> Quarter (Nov-Dec 2010)
6. Coordinate procurement process .....	3 <sup>rd</sup> Quarter (Jan-Feb 2011)
7. Inspect/accept new vehicle .....	3 <sup>rd</sup> Quarter (Feb-Mar 2011)
8. Prepare new vehicle for on-road service.....	4 <sup>th</sup> Quarter (Apr-May 2011)
9. Implement new vehicle .....	4 <sup>th</sup> Quarter (June 2011)
10. Surplus old vehicle (ID 71-05).....	4 <sup>th</sup> Quarter (June 2011)

This grant request is for the purchase of a new waterless broom street sweeper and includes all tasks listed above.

### **Self-Monitoring Program**

*Describe how the project objectives will be measured and reported to the District on a quarterly basis.*

The EDCDOT project manager for this project will provide the District, if requested and at intervals determined by the District, with project progress reports detailing the work performed during the current reporting period; work planned for the next reporting period; problems identified, solved, and/or unresolved; and the percentage of each task completed. A comprehensive final written report, documenting the work performed, will be provided to the District prior to the end of the Agreement term.



**RESOLUTION NO.** 273-2008

**OF THE BOARD OF SUPERVISORS OF THE COUNTY OF EL DORADO**

**RESOLUTION AUTHORIZING THE DIRECTOR OF TRANSPORTATION TO SUBMIT GRANT APPLICATIONS AND EXECUTE GRANT AGREEMENTS FOR VARIOUS FUNDING PROGRAMS**

WHEREAS, the County of El Dorado Transportation Department intends to pursue various local, State and Federal funding opportunities to augment the Transportation Department's project delivery, maintenance and operations programs; and

WHEREAS, the County of El Dorado Transportation Department intends to periodically submit grant applications for various local, State and Federal transportation funding programs, and other qualified grant funding opportunities that become available; and if awarded, will enter into agreements with various Grantors for implementation of said grants; and

WHEREAS, the County of El Dorado Transportation Department has the non-General Fund discretionary budget available for matching funds that may be required for the various grant programs;

NOW, THEREFORE, BE IT RESOLVED that the Board of Supervisors of the County of El Dorado hereby:

1. Authorizes the County of El Dorado Transportation Department to submit grant applications for various local, State and Federal transportation funding programs, and other grant funding opportunities that become available;
2. Authorizes the Director of Transportation, or the Chief Administrative Officer, to sign in the name of the County of El Dorado all necessary documents required to submit grant applications;
3. Authorizes the Director of Transportation to execute grant agreements subject to County Counsel and Board of Supervisors review and approval;
4. Authorizes this resolution to apply retroactively to the El Dorado County AQMD July 2008 award of AB2766 DMV Surcharge Funds for the vehicle replace purchase of a waterless/dustless broom street sweeper and ratifies the Director of Transportation's signature on those grant documents.

PASSED AND ADOPTED by the Board of Supervisors of the County of El Dorado at a regular meeting of said Board held on the 7 day of October, 2008, by the following vote of said Board:

Ayes: Baumann, Santiago, Dupray, Sweeney, Briggs

ATTEST:

Cindy Keck

Clerk of the Board of Supervisors

Noes: none

Absent: none

By: [Signature]  
Deputy Clerk

By: [Signature]  
Chairman, Board of Supervisors  
Rusty Dupray

I CERTIFY THAT:

THE FOREGOING INSTRUMENT IS A CORRECT COPY OF THE ORIGINAL ON FILE IN THIS OFFICE.

DATE: 10/7/08

ATTEST: CINDY KECK, Clerk of the Board of Supervisors of the County of El Dorado, State of California.

By: [Signature]  
Deputy Clerk

# COUNTY OF EL DORADO

# DEPARTMENT OF TRANSPORTATION



**MAINTENANCE DIVISION**  
2441 Headington Road  
Placerville CA 95667  
Phone: (530) 642-4909  
Fax: (530) 642-9238

**JAMES W. WARE, P.E.**  
Director of Transportation  
  
Internet Web Site:  
<http://co.el-dorado.ca.us/dot>

**MAIN OFFICE**  
2850 Fairlane Court  
Placerville CA 95667  
Phone: (530) 621-5900  
Fax: (530) 626-0387



March 26, 2010

El Dorado County AQMD  
2850 Fairlane Court  
Placerville, CA 95667  
**Attn: Kerri Williams, Time Critical**

Dear Ms. Williams,

**Subject: Matching Funds for Department of Transportations's project proposal for FY 10/11 Motor Vehicle Emission Reductions (AB2766 DMV Surcharge Fees) Funding**

The Department of Transportation (DOT) is submitting a proposal for FY 2010/11 Motor Vehicle Emission Reductions (AB2766 DMV Surcharge Fees) funding to purchase a new **waterless/dustless broom street sweeper** to replace an existing 2001 Schwarze regenerative air street sweeper.

The matching funds included in DOT's proposal are derived from available Road Fund discretionary monies. Matching funds of \$59,538 is included in the FY 2010/11 Road Fund budget and will be available July 1, 2010.

If you have any questions, please contact me at (530) 621-5934.

Sincerely,

Ruth Young  
Chief Fiscal Officer

RY:an

## Cleaner Street Sweeper Purchases

**Air District Name:** El Dorado County APCD

**Local Government Name:** Not Applicable

**Project Name:** Waterless Street Sweeper

**Description:** Purchase one new replace waterless/dustless street sweeper  
**(Issues/Comments)**

**Implementing Agency:** El Dorado County DOT

**Private Agency:** No

<b>MVFees Funding:</b>	\$267,919	<b>Main Engine Fuel:</b>	1,320 gal/yr
<b>MSRC Funding:</b>	\$0	<b>Auxiliary Engine Fuel:</b>	2,640 gal/yr
<b>Moyer Funding:</b>	\$0	<b>Miles Swept:</b>	4,200 miles/yr
<b>CMAQ Funding:</b>	\$0		
<b>Other CoFunding</b>	\$29,769		
<b>Capital Recovery Factor:</b>	0.12		
<b>Project Analysis Period:</b>	10 years		

### EMISSION FACTORS:

	Baseline Vehicle Emission Factors		Cleaner Vehicle Emission Factors	
	Main Engine	Auxiliary Engine	Main Engine	Auxiliary Engine
<b>ROG :</b>	0.00	0.99 g/bhp-hr	0.00	0.10 g/bhp-hr
<b>NOx :</b>	2.79	6.90	0.40	2.89
<b>PM10 :</b>	0.02	0.69	0.02	0.20

### EMISSION REDUCTIONS:

	Pounds per Year	Kilograms per Day	
<b>ROG:</b>	96	0.12	PM10 Reductions from Sweeping ONLY:
<b>NOx:</b>	560	0.70	
<b>PM10:</b>	263	0.33	
<b>Total:</b>	<u>919</u>	<u>1.14</u>	210 lbs/yr

### COST-EFFECTIVENESS OF:

<b>Motor Vehicle Fees plus Moyer Funds:</b>	\$34.19	per pound	\$68,374	per ton
<b>CMAQ Funds:</b>	\$0.00	per pound	\$0	per ton
<b>All Funding Sources:</b>	\$37.99	per pound	\$75,971	per ton

1

**Cleaner Street Sweeper Purchases**

**Air District Name:** El Dorado County APCD

**Local Government Name:** Not Applicable

**Project Name:** Waterless Street Sweeper

**Description:** Purchase one new replace waterless/dustless street sweeper  
(Issues/Comments)

**Implementing Agency:** El Dorado County DOT

**Private Agency:** No

<b>MVFees Funding:</b>	\$253,035	<b>Main Engine Fuel:</b>	1,320 gal/yr
<b>MSRC Funding:</b>	\$0	<b>Auxiliary Engine Fuel:</b>	2,640 gal/yr
<b>Moyer Funding:</b>	\$0	<b>Miles Swept:</b>	4,200 miles/yr
<b>CMAQ Funding:</b>	\$0		
<b>Other CoFunding</b>	\$44,653		
<b>Capital Recovery Factor:</b>	0.12		
<b>Project Analysis Period:</b>	10 years		

**EMISSION FACTORS:**

	<b>Baseline Vehicle Emission Factors</b>		<b>Cleaner Vehicle Emission Factors</b>	
	<i>Main Engine</i>	<i>Auxiliary Engine</i>	<i>Main Engine</i>	<i>Auxiliary Engine</i>
<b>ROG :</b>	0.00	0.99 g/bhp-hr	0.00	0.10 g/bhp-hr
<b>NOx :</b>	2.79	6.90	0.40	2.89
<b>PM10 :</b>	0.02	0.69	0.02	0.20

**EMISSION REDUCTIONS:**

	<b>Pounds per Year</b>	<b>Kilograms per Day</b>	
<b>ROG:</b>	96	0.12	PM10 Reductions from Sweeping ONLY:
<b>NOx:</b>	560	0.70	
<b>PM10:</b>	263	0.33	
<b>Total:</b>	<b>919</b>	<b>1.14</b>	210 lbs/yr

**COST-EFFECTIVENESS OF:**

<b>Motor Vehicle Fees plus Moyer Funds:</b>	\$32.29	per pound	\$64,576	per ton
<b>CMAQ Funds:</b>	\$0.00	per pound	\$0	per ton
<b>All Funding Sources:</b>	\$37.99	per pound	\$75,971	per ton

**Cleaner Street Sweeper Purchases**

**Air District Name:** El Dorado County APCD

**Local Government Name:** Not Applicable

**Project Name:** Waterless Street Sweeper

**Description:** Purchase one new replace waterless/dustless street sweeper  
**(Issues/Comments)**

**Implementing Agency:** El Dorado County DOT

**Private Agency:** No

**MVFees Funding:** \$238,150    **Main Engine Fuel:** 1,320 gal/yr  
**MSRC Funding:** \$0    **Auxiliary Engine Fuel:** 2,640 gal/yr  
**Moyer Funding:** \$0    **Miles Swept:** 4,200 miles/yr  
**CMAQ Funding:** \$0  
**Other CoFunding** \$59,538  
**Capital Recovery Factor:** 0.12  
**Project Analysis Period:** 10 years

**EMISSION FACTORS:**

	<b>Baseline Vehicle Emission Factors</b>		<b>Cleaner Vehicle Emission Factors</b>	
	<i>Main Engine</i>	<i>Auxiliary Engine</i>	<i>Main Engine</i>	<i>Auxiliary Engine</i>
<b>ROG :</b>	0.00	0.99 g/bhp-hr	0.00	0.10 g/bhp-hr
<b>NOx :</b>	2.79	6.90	0.40	2.89
<b>PM10 :</b>	0.02	0.69	0.02	0.20

**EMISSION REDUCTIONS:**

	<b>Pounds per Year</b>	<b>Kilograms per Day</b>	
<b>ROG:</b>	96	0.12	PM10 Reductions from Sweeping ONLY:
<b>NOx:</b>	560	0.70	
<b>PM10:</b>	263	0.33	
<b>Total:</b>	<b>919</b>	<b>1.14</b>	210 lbs/yr

**COST-EFFECTIVENESS OF:**

<b>Motor Vehicle Fees plus Moyer Funds:</b>	\$30.39	per pound	\$60,777	per ton
<b>CMAQ Funds:</b>	\$0.00	per pound	\$0	per ton
<b>All Funding Sources:</b>	\$37.99	per pound	\$75,971	per ton

1



ENVIRONMENTAL SALES • SERVICE • SUPPLIES

February 7, 2010

County of El Dorado  
2441 Headington Road  
Placerville, CA 95667

Attention: Dennis Milligin, Equipment Superintendent

Subject: Waterless Eagle Proposal

Pursuant to your request, attached for your guidance and information is a proposal of a new Waterless Eagle unit that matches the Waterless Eagle already owned and operated by the County of El Dorado.

<b>WATERLESS EAGLE - DUAL</b>	<b>\$275,000.00</b>
Tier II engine, hydraulically driven left and right side brooms and variable height, right side dumping, 4.5 cu. yd. hopper, sweeper is powder coated from powder coatings chart 2003/N with powder coated gray undercarriage and includes the standard features listed below.	

**CHASSIS**

'09 UD3300 DUAL STEER	INCL.
-----------------------	-------

**CHASSIS MOUNTING CHARGE**

UD3300 DUAL STEER - CHASSIS ALTERATIONS	INCL.
---	-------

PAINT CAB STANDARD WHITE	INCL.
--------------------------	-------

Portland 12831 NE Whitaker Way • PO Box 30959 • Portland, OR 97294  
(503) 255-9055 • fax (503) 256-3880  
Kent 848 3rd Ave South • Kent, WA 98032  
(253) 852-5818 • fax (253) 852-8913  
[www.owenequipment.com](http://www.owenequipment.com)

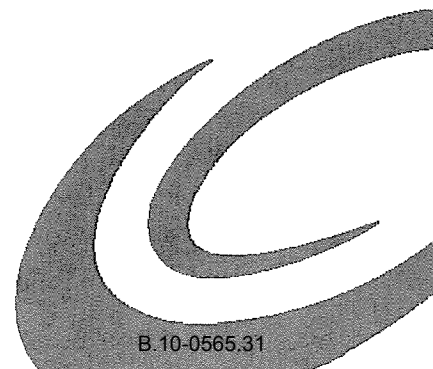



**STANDARD FEATURES**

Air conditioning  
 Air cleaner, dry type with safety element and restriction indicator:  
   truck & sweeper engines  
 Alternator, 120 amp, sweeper  
 Alternator, 130 amp, truck (GMC)  
 Auxiliary engine:  
   John Deere 4024TF270, in-line 4 cylinder  
   Horsepower: 49 HP (36.7 kW) at 2800 RPM  
   Displacement: 149 cu. in. (2.3 L)  
   Torque: 127 lb ft (172 Nm) at 1680 RPM  
 Axle, rear, two-speed  
 Back-up alarm, electric  
 Battery, maintenance free, two  
 Brakes, full air  
 Broom, main air suspension, cab-controlled  
  
 Broom, main, down pressure gauge  
 Broom, main, double wrap  
 Camera, Rear with in-cab monitor  
 Conveyor, flushing system  
 Conveyor, lower roller washout  
 Dust Skirts  
 Engine, block heater, chassis  
 Engine, hour meter, sweeper  
 Fresh air ventilator/heater/defroster

Fuel tank, 50 gallon  
  
 Fugitive dust control filter with in-cab cleaning  
 Fugitive dust control fan  
 Hopper inspection door  
 Hose, hydrant fill, 16'8" (5080 mm) with strainer and coupling  
 Lights, automatic backup  
 Lights, 2 combination, tail/stop lights  
 Lights, flood light, one per broom  
 Lights, headlights, 2 dual rectangular  
 Light, water level  
 Manuals, operator and parts  
 Mirrors, West Coast type with 8" diameter convex, both sides  
 PM-10 compliant water system  
 Signals, self-canceling directional with hazard switch  
 Sun visors  
 Tachometer, engine, truck and sweeper  
 Rocker switch controls for all sweep hydraulic functions  
 Tow loops or tow pins, front only; tie-down hooks, rear  
 Transmission, Allison, standard with oil cooler  
 Water spray, anti-siphon fill  
 Water tank, molded polyethylene, 315 gallon total nominal capacity  
 Wheels, dual rear with tubeless radial tires  
 Windshield washer  
 Windshield wipers, two-speed, intermittent feature

-----ALARMS-----

CONVEYOR STALL ALARM	INCL.
----------------------	-------

-----AUTO LUBE-----

MIDWEST AUTOLUBE - SWEEPER ONLY	INCL.
---------------------------------	-------

-----BROOMS-----

CARBIDE DIRT SHOES	INCL.
--------------------	-------

Portland 12831 NE Whitaker Way • PO Box 30959 • Portland, OR 97294  
 (503) 255-9055 • fax (503) 256-3880  
 Kent 848 3rd Ave South • Kent, WA 98032  
 (253) 852-5818 • fax (253) 852-8913  
[www.owenequipment.com](http://www.owenequipment.com)

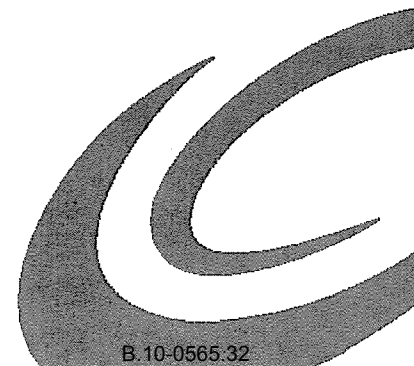





*ENVIRONMENTAL SALES • SERVICE • SUPPLIES*

**-----DECALS-----**

RED LOGO/SWOOSH - EAGLE WATERLESS	INCL.
--------------------------------------	-------

**-----LIGHTS-----**

LED/STOP/TAIL/REAR TURN LIGHT	INCL.
ARROWBOARD	INCL.
STROBE WIRE/MOUNT - FRONT & REAR	INCL.

**-----SWEEP COMPONENTS-----**

HEAVY DUTY LOWER CONVEYOR ROLLER	INCL.
RETURN SWEEP AFTER TRANSPORT	INCL.
EXTENDED HOPPER DOOR	INCL.
FAN SOUND DEFLECTOR	INCL.
CHEVRON CONVEYOR BELT	INCL.

**-----WATER-----**

25' WATER FILL HOSE	INCL.
WATER FILL GAUGE	INCL.

**-----INSTRUCTIONS-----**

EAGLE WATERLESS PARTS BOOK	INCL.
EAGLE WATERLESS OPERATORS MANUAL	INCL.
EAGLE WATERLESS SERVICE MANUAL	INCL.
JOHN DEERE POWERTECH SERVICE MANUAL	INCL.
JOHN DEERE 4045 TR-2 OPERATOR MANUL	INCL.
JOHN DEERE 4045 TR-2 PARTS BOOK	INCL.

**---UD3300 CHASSIS OPTIONS-**

AM/FM RADIO WITH CD	INCL.
5 YEAR BASE WARRANTY-100,000 MILES	INCL.
RH/LH HEATED REMOTE MIRRORS	INCL.
SINGLE AIR HORN	INCL.

Portland 12831 NE Whitaker Way • PO Box 30959 • Portland, OR 97294  
 (503) 255-9055 • fax (503) 256-3880  
 Kent 848 3rd Ave South • Kent, WA 98032  
 (253) 852-5818 • fax (253) 852-8913  
[www.owenequipment.com](http://www.owenequipment.com)

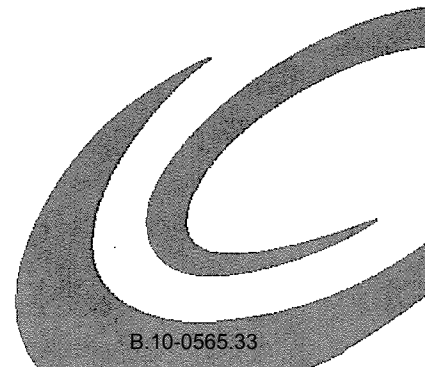



ENVIRONMENTAL SALES - SERVICE - SUPPLIES

IN CAB AIR RESTRICTOR	INCL.
AUTO AIR DRAIN VALVE	INCL.
SERVICE MANUAL - CD	INCL.
SIDE BROOM TILT- RIGHT	INCL.
SIDE BROOM TILT- LEFT	INCL.
FRONT SPRAY BAR	INCL.

-----FREIGHT RATES-----

FREIGHT-CA	INCL.
------------	-------

THE PROPERTY HEREIN IS GUARANTEED BY MANUFACTURER'S WARRANTY ONLY AND SELLER MAKES NO WARRANTY EXPRESSED OR IMPLIED, OF MERCHANTABILITY OR OTHERWISE, OR OF FITNESS FOR ANY PARTICULAR PURPOSE, THAT EXTENDS BEYOND THE ABOVE DESCRIPTION OF THE EQUIPMENT.

**NOTE:** Price is good for 60 Days. Cost increases due to the addition of Government mandated safety or environmental devices incurred after the date of this proposal, will be charged to you at our cost. Proof of such costs, if any, will be documented.

**TAXES:** SALES TAX applicable at time of delivery will be shown on our invoice. FEDERAL EXCISE TAXES, if applicable, will require payment unless a properly executed Exemption Certificate is submitted.

**DELIVERY:** 180-240 Days      **TERMS:** Net 10 Or Approved Lease

Thank you for the opportunity to earn your business. If you have any questions or if I can be of further assistance, please do not hesitate to give me a call at (707) 237-1020.

Best regards,

Ed Hodges  
General Manager

Portland 12831 NE Whitaker Way • PO Box 30959 • Portland, OR 97294  
(503) 255-9055 • fax (503) 256-3880  
Kent 848 3rd Ave South • Kent, WA 98032  
(253) 852-5819 • fax (253) 852-8913  
[www.owenequipment.com](http://www.owenequipment.com)



# ELGIN



# WATERLESS EAGLE<sup>®</sup>

# Waterless Advantage. Elgin Performance.



Have a limited water supply? Need to sweep year-round in all weather conditions? All while having to maximize your operator's productivity and sweeping efficiency? Then look no further than the popular Elgin Eagle, equipped with a new, patented Waterless Dust Control System and with proven PM10 and PM 2.5 pickup, proven low dust emissions and proven dry sweep performance.\*

With the Waterless Eagle, you get the incredible sweep performance that has made the Eagle a favorite, but you control dust without using water. And since there's no water, sweeping in freezing weather conditions is possible, helping you meet the growing demand for quick pick-up of winter-time road sand, salt and cinders. As a result, you significantly reduce time spent on spring clean-up.

To increase productivity, Eagle's Waterless Dust Control System means operators sweep more and spend less time filling tanks. Without water, mud doesn't build up on components, which can reduce clean-up time at the end of a shift. In addition, the process of dry sweeping provides environmental benefits, including a reduction in your water footprint and less road silt that can be left as a film from water-based dust control sweepers.

\*For information on performance test results consult factory.

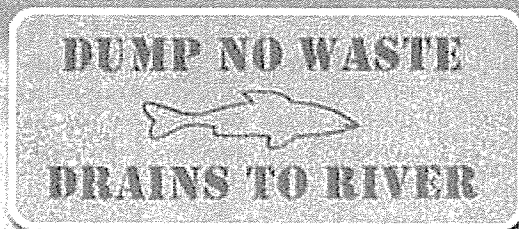

*Regular cleaning of streets and catch basins reduces sediment loads in runoff that would otherwise end up in local waterways*

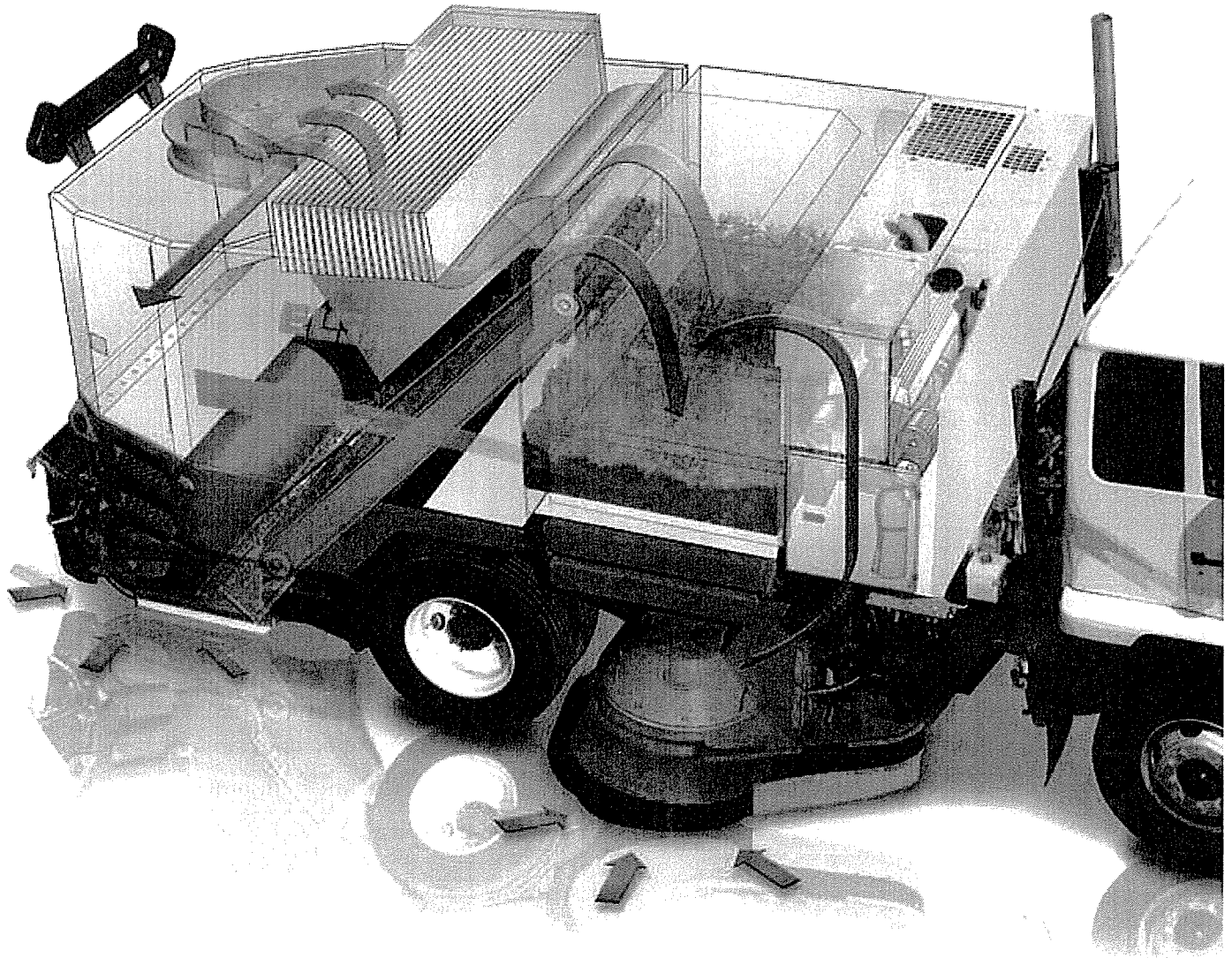

### **Wide Sweep Path**

Hydraulically driven main and side brooms create a wide 10 ft (3,048 mm) sweeping path for maximum productivity. The hydraulically driven main broom has in-cab variable broom speed for flexibility in varying sweeping conditions. Down pressure can be adjusted from the cab while moving. The main broom is mounted on a full-floating, trailing arm design with shocks to follow road contours. The 42 in (1,067 mm) free-floating, trailing arm side brooms provide powerful digging action and a full four-way motion and sideway protection when passing close to obstacles. Variable speed and down pressure for digging and wear control are controlled from in the cab. This means deep digging or light touch for maintenance sweeping.

### **No-Jam Conveyor**

The Eagle conveyor features molded-in, full-width cleats that move large debris without jamming. High-strength belt material provides long wear and maximum uptime. Controlled from the cab, including reverse, the conveyor assures efficient loading of heavy granular debris as well as bulky materials such as tire re-treads, hub caps, mufflers and more. The high speed of the belt throws material to the front of the hopper for more effective loading. Built-in washdown allows quick, easy clean-up.

### **Minimal Noise Levels**

Cab, chassis and sweeping system are designed for low in-cab and drive-by noise levels, providing maximum operator comfort and safety.

### **Variable Height Dump Hopper**

The 4.5 yd<sup>3</sup> (3.4 m<sup>3</sup>) volumetric hopper can be emptied anywhere from 32 inches (813 mm) to 10 ft 2 in (3,100 mm) and an 11 in (280 mm) right side shift enhances container or dump truck unloading. The hopper raises on a trouble-free, twin cylinder, dual stage mechanism, capable of lifting up to an 11,000 lb (5,000 kg) load. The center position keeps the weight between the dual tires during dumping operations and maintains proper weight distribution as the sweeper unloads. The load is clearly visible, and the dump angle is 50° for excellent dump performance and easy slide-out of material.

### Supplemental Water System

Every unit has a standard full water system to give operators the flexibility of using water should circumstances or preferences require it. It includes an in-cab controlled water flow for the main and side brooms. The 320 gal (1,210 L) system features removable, rustproof polyethylene water tanks and a self-priming centrifugal run-dry type pump that provides 6 gpm (22.7 L/min) @ 80 psi (5.8 bar).

### Proven Cab-Over Chassis

The Eagle is mounted on a high-visibility, commercial chassis and is available with right hand only drive or fully right and left dualized with chassis OEM components. The typical chassis features a 230 hp engine and five speed overdrive transmission and meets all FMVSS standards. The short 155 inch (3,937 mm) wheelbase provides a tight turning radius. The unique full air ride suspension provides comfort during transport, and the ability to deflate the airbags and provide a ridged axle for sweeping and dumping stability. (Consult factory for additional chassis options.)

### Easy In-Cab Operation

A center-mounted console provides access to all sweeper controls from either driving position. This includes hopper, conveyor, rear suspension, vacuum fan assist, adjustable spray water, broom controls, plus a full load indicator. Broom speed, conveyor speed and digging pressure are adjustable independently of truck rpm. Reverse gear automatically raises sweeping components to prevent damage. A complete set of auxiliary engine gauges keeps the operator informed at all times, including a tachometer, hour meter, voltmeter, fuel level, coolant temperature, oil pressure, hydraulic oil filter, engine running and air filter conditions.

### Convenient Maintenance Features

The Waterless Eagle is as easy to maintain as a standard Eagle. Four access doors (with locks) open wide for access to all sweep system components, auxiliary engine and the dry dust control components, including the fan and filter. Built-in steps and a steel service platform provide stable work surfaces. All wiring harnesses are color-coded and labeled for easy maintenance and troubleshooting. All connectors are weatherproof to prevent moisture from getting into the connection. Access to the side and main brooms is quick and requires no tools. The shrouds are hinged and easily latch and unlatch making routine maintenance trouble-free.

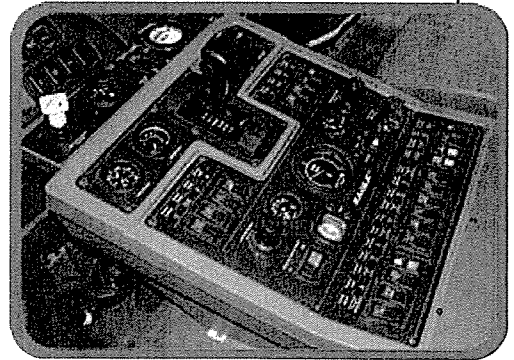
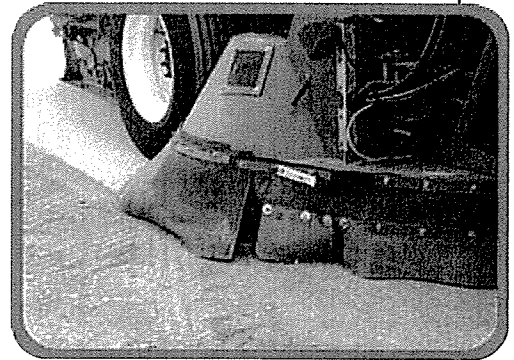

### Powerful Auxiliary Engine

A reliable 99 hp John Deere 4045 diesel auxiliary engine powers all sweep and dust control systems. The dedicated sweep system engine produces superior digging at required ground speed. The truck engine rpm and ground speed do not affect broom or conveyor speed.

### Dust Control System

The Eagle with Waterless Dust Control features a patented dust suppression system with a powerful vacuum fan to create an airstream, main and side broom skirting for dust capture, and a long-life, low maintenance filter between the hopper and the vacuum fan. Together, these components create a highly effective method for controlling fugitive dust that may occur during sweeping.

# Waterless Eagle® Patented Dust Control System

A powerful vacuum fan on the sweeper creates an air stream through the debris hopper, conveyor and skirted areas. The inward rushing air carries the airborne dust into the debris hopper, where it's allowed to settle out with the rest of the swept debris.

A majority of the fugitive dust falls into the hopper with only a small amount of dust getting to the filter. When the filter becomes loaded, it can be mechanically cleaned with an on-board cleaning system so sweeping can continue.

A long life, low maintenance dry filter element is installed between the debris hopper and the vacuum fan to prevent dust from being pulled from the hopper and blown out the vacuum fan exhaust.

The fully flexible main and side broom skirting allow efficient dust capture, while still providing aggressive curb cleaning. These are fabricated from highly resilient polymer material for long wear and are easy to change and maintain.

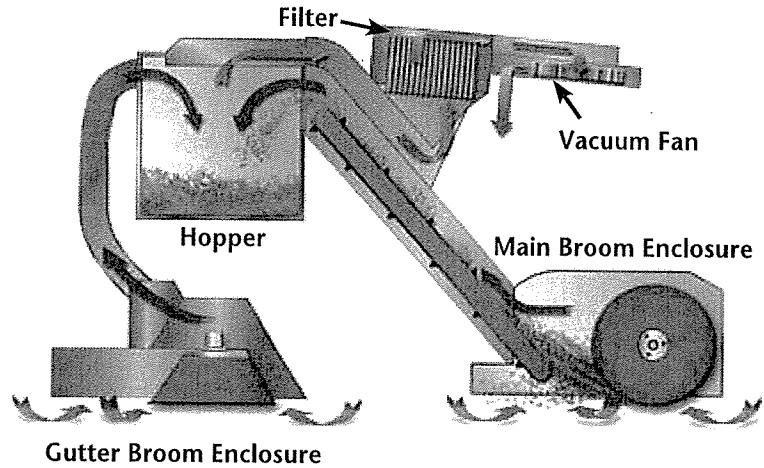

## Side Broom Maintenance - *Quick and Easy to Access!*



*Elgin Sweeper has a network of more than 100 dealer locations worldwide. So no matter where you work, Elgin Sweeper and your Elgin dealer are there to support and protect your investment upon delivery and for years down the road.*

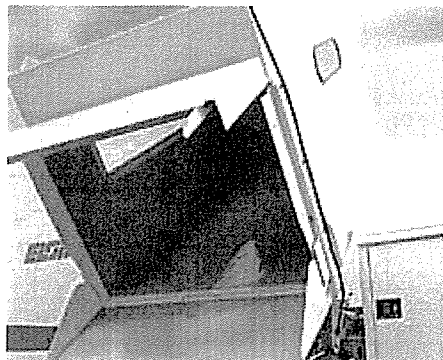

### LifeLiner® Hopper System

The LifeLiner® hopper system is a specially designed hopper liner and finish system that greatly improves the life, durability, and functionality of a sweeper hopper.

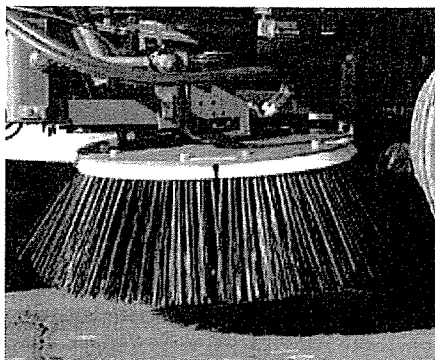

### In-Cab Side Broom Tilt

Allows operator to sweep effectively in variably-pitched gutters. On-the-go pitch adjustment with a simple variable rocker switch ensures proper broom angle.



### Cab-Over UD Chassis

UD 3300 chassis are built exclusively for Elgin and sweeping. This cab-over chassis provides outstanding visibility, comfort, safety and productivity. The short wheel base and unique steering geometry allows for maximum maneuverability. The UD 3300 can be equipped with full power single RH or dual steering. GMC Chassis also available.

### Additional Options

- Rotating beacon or strobe light
- Rotating beacon or strobe light guard
- Carbide dirt shoes
- Arrow Board
- Auto-lube automatic lubrication system
- Automatic engine shutdown (high temp/low pressure)
- Main broom hour meter
- One-touch sweep resume system

Consult factory for additional options.

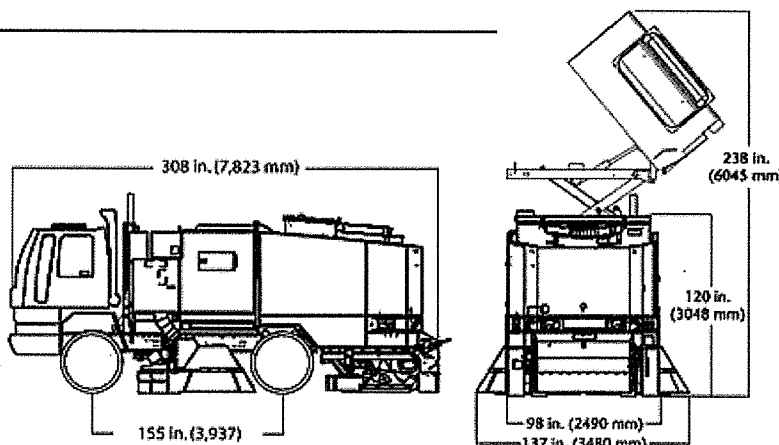

### General Specifications

- Sweep System: No-Jam Conveyor
- Sweeping Path (Max): 10 ft (3,048 mm)
- Hopper Capacity (volumetric): 4.5 yd<sup>3</sup> (3.5 m<sup>3</sup>)
- Dust Suppression: Waterless Dust Control System
- Auxiliary Water System: 320 gal (1,210 L)
- Dumping Height (max): 10 ft 2 in (3,100 mm)
- Dump Location: Right Side

### Warranty

Elgin Sweeper Company backs the Eagle sweeper with a one-year limited warranty. The Eagle is warranted against defects in material or workmanship for a period of 12 months from the date of delivery to the original purchaser. Optional extended warranty packages are available. Consult your Elgin Sweeper dealer for complete warranty details.

Your Local Elgin Dealer is:

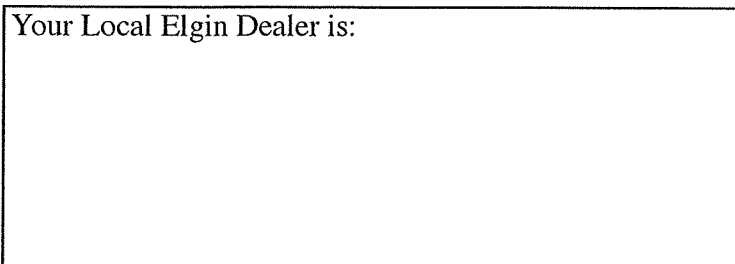

Elgin Sweeper Company  
Subsidiary of Federal Signal Corporation  
1300 W. Bartlett Road  
Elgin, Illinois, U.S.A. 60120-7529  
(847) 741-5370 Phone  
(847) 742-3035 Fax  
www.elginsweeper.com

Specifications subject to change without notice. Some items shown may be optional. Elgin® and Eagle® are registered trademarks of Elgin Sweeper Company. Effective 5/09 P/N 0705358-B Printed in U.S.A. ©Elgin Sweeper Company, 2009

### ISO-9001 and PM-10 Advantages

The Eagle is manufactured in an ISO-9001 facility. John Deere is a registered trade mark of Deere & Company.



## 2009 UD3300 Right Hand single steer chassis specification for EAGLE Waterless

**AXLES:**

Front - 12,000 lbs. (5,454 kg) with 11,900 lbs. (5,409 kg) springs  
 Rear - Two speed 21,000 lbs. (9,545 kg) with 21,000 (9,545 kg) air bag suspension, solid axle during sweep and dump, fully sprung during transport.  
 Ratio - 5.86/8.17:1  
 Gross Vehicle Weight Rated (GVWR) - 32,900 lbs. (14,555 kg)

**BRAKES:**Service:

Type - Full air, anti-lock  
 Front - 16.1 in. x 5.9 in. (410 mm x 150 mm) drum  
 Rear - 16.5 in. x 7 in. (419 mm x 178 mm) drum  
 Compressor Capacity - 20.8 CFM  
 Dryer - desiccant type  
 Auto slack adjusters, front and rear

Air

Parking:

Type - Spring set, air release

**CHASSIS:**

Manufacturer: UD Trucks  
 Model - UD3300

Frame:

Type - Rail, High Strength, 51,200 PSI, 35.7 section modulus, 1,828,000 RBM  
 Size - 9.8 in. x 3.2 in. x 0.331 in. (262 mm x 89 mm x 8.7 mm)

**DIMENSIONS: (with sweeper mounted)**

Wheelbase - 150 in. (3813 mm)  
 Cab to axle - 118 in. (2997 mm) usable  
 Overall Length - 301 in. (7645 mm)  
 Overall Height - 110 in. (2794 mm) Top of cab  
 Overall Width - 96 in. (2438 mm)  
 Dumping Clearance Height - 236 in. (5994 mm)  
 SAE Turning Radius - 21 ft. 8 in. (6629 mm)  
 Travel Speed - 65 MPH

**ELECTRICAL SYSTEM:**

Voltage - 12V  
 Alternator - 130 Amp.  
 Battery - Two (2) 12 Volt 1244 CCA total Maintenance Free

**WARNING LIGHTS and CHIMES:**

ABS warning light  
 Alternator low charge warning light  
 Cab lock warning light and buzzer  
 Engine control system warning light and buzzer  
 Engine glow plug indicator light  
 Exhaust brake indicator light  
 Air cleaner mounted air restriction indicator  
 Hazard warning flasher  
 High beam indicator light  
 Low air pressure warning light and buzzer  
 Low coolant level and overheating warning light and buzzer  
 Low oil pressure warning light  
 Fuel/water separator warning light  
 Parking brake indicator light  
 Turn signal indicator lights  
 Warning lights have burnt-out bulb check function  
 Transmission temperature high light

**SEATS:**

R.H. Air ride, adjustable, cloth covered  
 L.H. adjustable, cloth covered

**STEERING:**

Type - Full power hydraulic  
 Tilt Telescope column

**TRANSMISSION:**

Allison 2500 Series electronic/5 speed overdrive

**WHEELS:**

Front & Rear - 22.5 in. x 7.5 in. (572 mm x 191 mm)  
 stud pilot steel disc

**TIRES:**

Front & Rear - 11R 22.5  
 Load Range G (14 ply rating)  
 Goodyear

**ADDITIONAL FEATURES INCLUDED:**

Air Conditioner  
 Auto Shutdown  
 Block Heater, 1000 Watt  
 Viscous Fan  
 Tinted Glass—All Windows  
 Dual heated West Coast Mirrors  
 Convex Mirrors (L & R) 8.5 in. (216 mm)  
 Cruise control  
 windows Power Remote entry

<p><b>ENGINE:</b>          Manufacturer: Hino          Model – MD230          Cylinders - In-Line 6          Displacement - 469 cu.in. (7.7 L)          Horsepower - 230 @ 2500 RPM          Torque - 506 lb. ft. @ 1500 RPM          Oil Filter - Full-flow, spin on type          Oil Capacity -13.5qt (12.8L) with filter          Air Cleaner - Single stage, dry type w/ safety element          Fuel Tank Capacity - 50 gal. (189 L)          Fuel Filter/Water Separator          Exhaust – EPA 07 Emissions with particulate trap.          Vertical L.H. behind cab. Ultra low NOx with CARB          idle restriction exemption.</p> <p><b>INSTRUMENTS:</b>          Water temp. gauge, tachometer, speedometer with trip          odometer, fuel gauge, air pressure</p>	<p>Intermittent two speed wipers.          Cigar lighter          running lights          light</p> <p style="text-align: right;">Daytime          Interior map          Halogen headlamps</p> <p><b>OPTIONAL EQUIPMENT AVAILABLE:</b>          Front Tow Hooks          Ballistic nylon seat covers          painted color not Elgin white          mirrors          engine extended warranty (5 yr)          Transmission extended warranty (5 yr)          CD radio          drain valves          Hour Meter          In-Cab Air Cleaner Restriction Indicator</p> <p style="text-align: right;">Cab          Motorized          Chassis and          Allison          AM/FM          Automatic air tank          Single air horn</p> <p><b>NOTE:</b> These specifications are subject to change          without notice.</p> <div style="border: 1px solid black; width: 100px; height: 20px; margin: 10px 0;"> <span style="border: 1px solid black; padding: 2px;">x</span> </div> <p>Elgin Sweeper Company          1300 West Bartlett Road          Elgin, IL 60120          Ph: (847) 741-5370          Fax: (847) 742-3035</p>
---	---

Sweep System - Power

**Engine**  
 Make John Deere 4045  
 Type 4 cylinder, diesel  
 Displacement 276 cu in (4.5L)  
 Bore 4.16 in (106.43 mm)  
 Stroke 5.0 in (127 mm)  
 Compression ratio 17.1  
 Horsepower 99 HP (74 kW) @ 2,500 RPM  
 Torque 215 ft-lbs (292 Nm) @ 1,200 RPM  
 Fuel tank capacity 50 gal (190 L)

**Standard Accessories**  
 Full flow oil filter, mechanical governor, heavy-duty dual dry type air cleaner with safety element precleaner, fuel filter, fuel/water separator, coolant recovery.  
**Instrumentation**  
 Gauges for- Tachometer/hour meter, oil pressure, engine water temperature, and charging system  
 Control console warning lights for full load, Engine oil system, aux. engine running, hydraulic oil filter restriction, hopper up, machine level, low spray water, air filter, high aux. engine water temperature.

Electrical System

Sweeper wires color coded and labeled with circuit identification every four inches; connectors plated and polarized. 12V negative ground with minimum 130 amp truck alternator and 120 amp sweeper alternator. All circuits protected by circuit breakers and/or fuses. 1000 CCA auxiliary engine battery.

Sweep System - Components

**General Specifications**  
**Sweeping path:**  
 Main broom only  
 60 in (1524 mm)  
 Main broom and one side broom  
 90 in (2286 mm)  
 Main broom and two side brooms  
 120 in (3048 mm)  
**Main Broom**  
 Diameter 35 in (889 mm) Length 60 in (1524 mm)  
 Type Prefab. disposable, polypropylene filled  
 Core diameter 8.5 in (216 mm)  
**Digging pressure & wear control**  
 Pneumatic, in-cab  
**Lift control** Pneumatic, in-cab  
**Drive** Hydraulic motor/direct drive  
**Mounting** Full floating, trailing arm, with shocks  
**Speed** Variable with auxiliary engine RPM  
**Bearings** Sealed, self-aligning, re-lube  
**Pressure gauge** In-cab  
**Gutter Broom**  
 Type 5 segment nylon disposable with wire fill  
 Diameter 42 in (1067 mm)  
 Disc construction Steel plate  
**Speed** Variable with auxiliary engine RPM  
**Flexibility** Spring biased sideways oscillation  
**Drive** Direct hydraulic, reversible, from cab  
**Mounting** Free floating, trailing arm  
**Adjustment** Inward, outward/forward, backward  
**Digging pressure/wear control**  
 Pneumatic, from cab  
**Lift control** Pneumatic lift with hydraulic extend  
**Broom material** 26 in (660 mm) wire

**Conveyor**  
 Type Belt with molded-in rubber cleats  
 Material (belt) Rubber reinforced fabric  
 Speed Variable with auxiliary engine RPM  
 Flexibility 9 in (229 mm) oscillation for large object passage  
 Drive Reversible, direct drive hydraulic motor  
 Lift control Pneumatic  
 Bearings Sealed, self-aligning, re-lube

**Debris Hopper—Series FW**  
 Capacity volumetric 4.5 cu. yd. (3.5 cu. m)  
 Material volume 3.3 cu. yd. (2.5 cu. m)  
**Hopper lift and dump control** Hydraulic in-cab  
**Inspection Door** With access step  
**Maximum dump height**  
 (bottom of discharge door) 10 ft 2 in (3100 mm)  
**Minimum dump height**  
 (bottom of discharge door) 38 in (965mm)  
**Maximum hopper dump angle** 50°  
**Time to reach maximum dump height** 20 sec  
**Time to tilt hopper** 13 sec  
**Maximum time for full height lift, dump, and lower cycle** 70 sec  
**Design lift capacity** 11,000 lbs (5,000 kg)  
**Lifting method** Twin cylinder, two stage scissors  
**Right side dumping** Standard

**Pneumatic System**  
 Compressor Chassis Engine Mounted  
 Air dryer Heated  
**Hydraulic System**  
**Sweep System Pump** Three section gear drive with dual inlet  
**Capacity** 26 GPM (98 LPM) @ 2500 RPM  
**Dust Control System Pump** Single Section Piston 25 GPM (LPM) @2500 RPM  
**Fittings** 'O' ring seal type  
**Reservoir capacity** 32 gal (121 L)  
**Reservoir level** Externally readable  
**Inlet strainer** 100 mesh  
**Filter, return** 10 micron, full flow with bypass  
**Filter restriction indicator** In-cab  
**Breather** 10 micron, spin-on  
**Wet Dust Control System**  
**Tank construction** Polyethylene, removable  
**Tank capacity** 320 gal (1210 L)  
**Fill hose** Anti-siphon, 16 ft 8 in (5080 mm) with strainer and 2.5 in (64 mm) NST coupling  
**Wash down** Lower conveyor  
**Conveyor flusher** Built-in cascade-type  
**Pump** Centrifugal, 6 GPM @ 80 psi (22.7 LPM @5.8 bar)  
 Broom dust control atomizing nozzles  
 Controls on/off in-cab  
 Non corrosive housing, 100 mesh screen.  
**Dry Dust Control System**  
 Centrifugal dust evacuation fan. Large envelope filter with hydraulic shaker for dust removal.  
 Dust control skirts on side and main brooms.  
 Dust separator screen in hopper.

Available Enhancements

Extended Warranty on sweeper  
 Strobe light  
 Rotating beacon  
 Light protector for beacon or strobe  
 Fire extinguisher  
 Carbide dirt shoes  
 Front spray bar  
 Arrowboard  
 In-cab side broom tilt with visual indicator

Automatic lubrication system  
 Engine shutdown temperature/pressure  
 Lifeliner® hopper liner  
 Silicone hoses on auxiliary engine

Paint

Powder Coat:  
 Undercarriage in standard Elgin gray  
 Body in choice of 186 colors  
 Consult factory for color chart

Chassis

Contact your Elgin dealer for detailed specifications.

Warranty

Sweeper 1 year parts and labor  
 Chassis & Aux. Engine Consult factory

Your Elgin Dealer is:

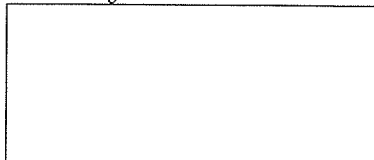

Elgin Sweeper Company  
 1300 W. Bartlett Rd.  
 Elgin, Illinois, U.S.A. 60120-7529  
 847-741-5370 Phone  
 847-742-3035 Fax  
 www.elginsweeper.com

Printed in U.S.A. © 2009 Federal Signal Corporation  
 Federal Signal Corporation is listed on the NYSE by the symbol FSS

Effective 6/09 P/N: 0705326-D  
 Specifications subject to change without notice

Eagle FW 4 Wheel Broom Waterless Dust Control