

Appendix E

Geotechnical Engineering Study

**GEOTECHNICAL ENGINEERING STUDY
FOR
DIAMOND SPRINGS COMMUNITY PARK**
Oak Dell Road
Diamond Springs, California

Project No. E23142.000
July 2023

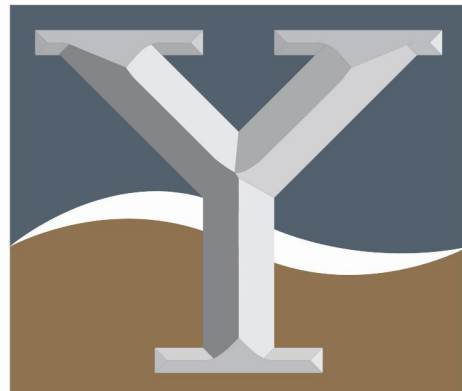

YOUNGDAHL
ESTABLISHED 1984

Dudek
605 Third Street
Encinitas, California 92024

Project No. E23142.000
21 July 2023

Attention: Mr. Scott Peterson

Subject: **DIAMOND SPRINGS COMMUNITY PARK**
Oak Dell Road, Diamond Springs, California
GEOTECHNICAL ENGINEERING STUDY

References: 1. Plans for Diamond Springs Community Park, no author, dated 4 October 2022.
2. Fully Executed Agreement for Diamond Springs Community Park, prepared by Dudek, dated 17 April 2023 (Project No. E23142.000).

Dear Mr. Peterson:

In accordance with your authorization of the Reference 2 proposal and contract, Youngdahl Consulting Group, Inc. has prepared this geotechnical engineering study for the project site located to the east of Oak Dell Road in Diamond Springs, California. The purpose of this study was to prepare a site-specific geotechnical report that can be incorporated into design of the proposed site. To complete this task, our firm completed a subsurface exploration, laboratory testing of collected soil samples, and prepared this report in accordance with the Reference 2 proposal and contract.

Based upon our observations, the geotechnical aspects of the site appear to be suitable for support of the proposed structure provided the recommendations presented in this report are incorporated into the design and construction. Geotechnical conditions associated with site development are anticipated to include the presence of shallow bedrock and the excavation and drainage characteristics associated with these materials.

Due to the non-uniform nature of soils, other geotechnical issues may become more apparent during grading operations which are not listed above. The descriptions, findings, conclusions, and recommendations provided in this report are formulated as a whole; specific conclusions or recommendations should not be derived or used out of context. Please review the limitations and uniformity of conditions section of this report.

This report has been prepared for the exclusive use of the addressee of this report and their consultants, for specific application to this project, in accordance with generally accepted geotechnical engineering practice. Should you have any questions or require additional information, please contact our office at your convenience.

Very truly yours,
Youngdahl Consulting Group, Inc.

Reviewed By:

Allie Denny
Staff Geologist

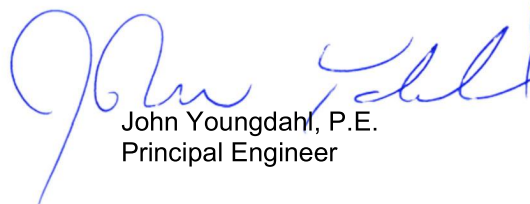
John Youngdahl, P.E.
Principal Engineer



Distribution: PDF to Client

7-21-23

TABLE OF CONTENTS

| | | |
|-------------------------|--|-----------|
| 1.0 | INTRODUCTION | 1 |
| | Project Understanding | 1 |
| | Background | 1 |
| | Purpose and Scope | 1 |
| 2.0 | SITE CONDITIONS | 1 |
| | Surface Observations | 2 |
| | Subsurface Conditions | 2 |
| | Groundwater Conditions | 2 |
| 3.0 | GEOTECHNICAL SOIL CHARACTERISTICS | 2 |
| | Laboratory Testing..... | 2 |
| | Soil Expansion Potential | 3 |
| 4.0 | GEOLOGY AND SEISMICITY | 3 |
| | Geologic Conditions | 3 |
| | Naturally Occurring Asbestos | 3 |
| | Seismicity | 4 |
| | Earthquake Induced Liquefaction, Settlement, and Surface Rupture Potential | 4 |
| | Static and Seismically Induced Slope Instability | 5 |
| 5.0 | DISCUSSION AND CONCLUSIONS | 5 |
| | Geotechnical Considerations for Development..... | 5 |
| 6.0 | SITE GRADING AND EARTHWORK IMPROVEMENTS | 6 |
| | Excavation Characteristics | 6 |
| | Soil Moisture Considerations | 6 |
| | Site Preparation..... | 6 |
| | Engineered Fill Criteria | 7 |
| | Slope Configuration and Grading..... | 9 |
| 7.0 | DESIGN RECOMMENDATIONS | 9 |
| | Shallow Conventional Foundations..... | 9 |
| | Deep Foundations | 11 |
| | Slab-on-Grade Construction | 12 |
| | Exterior Flatwork | 13 |
| | Retaining Walls | 13 |
| | Asphalt Concrete Pavement Design | 15 |
| | Portland Cement Concrete Pavement Design | 16 |
| | Drainage..... | 17 |
| 8.0 | DESIGN REVIEW AND CONSTRUCTION MONITORING | 19 |
| | Plan Review | 19 |
| | Construction Monitoring..... | 19 |
| | Post Construction Drainage Monitoring | 20 |
| 9.0 | LIMITATIONS AND UNIFORMITY OF CONDITIONS | 20 |
| APPENDIX A | 22 | |
| | Introduction | 23 |
| | Vicinity Map (Figure A-1) | 24 |
| | Site Map (Figure A-2) | 25 |
| | Logs of Exploratory Test Pits (Figures A-3 through A-11)..... | 26 |
| | Soil Classification Chart and Log Explanation (Figure A-12)..... | 35 |



| | |
|---|-----------|
| APPENDIX B | 36 |
| Direct Shear Test (Figure B-1)..... | 37 |
| Expansion Index Test (Figure B-2) | 38 |
| Modified Proctor Test (Figure B-3)..... | 39 |
| R-Value Test (Figure B-4)..... | 40 |
| APPENDIX C | 41 |
| Geotechnical Details (Figure YCG-1) | 42 |

GEOTECHNICAL ENGINEERING STUDY FOR DIAMOND SPRINGS COMMUNITY PARK

1.0 INTRODUCTION

This report presents the results of our geotechnical engineering study performed for the proposed park planned to be constructed east of Oak Dell Road in Diamond Springs, California. The vicinity map provided on Figure A-1, Appendix A shows the approximate project location.

Project Understanding

We understand that proposed development will consist of the construction of a recreational park in Diamond Springs, California. The park is proposed to consist of soccer fields, tennis courts, a basketball court, softball fields, an indoor gym, field lights, retaining walls, parking lots, shade structures, restroom buildings, a picnic area, children's play areas, and open turf areas. The building structures are anticipated to be supported by conventional shallow foundations with concrete slab-on-grade floors and isolated pad or pier foundations for the remaining structures.

Background

Based on a limited review of aerial imagery, the site appears to have been vacant land since 1946. Between 1946 and 1984, the lift station located on the site appears to have constructed. Additionally, several residences adjacent to the northern portion of the site and a school to the west were built. Since then, the project site has remained relatively unchanged.

If studies or plans pertaining to the site exist and are not cited as a reference in this report, we should be afforded the opportunity to review and modify our conclusions and recommendations as necessary.

Purpose and Scope

Youngdahl Consulting Group, Inc. has prepared this report to provide geotechnical engineering recommendations and considerations for incorporation into the design and development of the site. The following scope of services were developed and performed for preparation of this report:

- A review of geotechnical and geologic data available to us at the time of our study;
- Performance of a field study consisting of a site reconnaissance and shallow subsurface explorations to observe and characterize the subsurface conditions;
- Laboratory testing on representative samples collected during our field study;
- Evaluation of the data and information obtained from our field study, laboratory testing, and literature review for geotechnical conditions;
- Development of the following geotechnical recommendations and considerations regarding earthwork construction including, site preparation and grading, engineered fill criteria, seasonal moisture conditions, excavation characteristics, slope configuration and grading, and drainage;
- Development of geotechnical design criteria for code-based seismicity, foundations, slabs on grade, and retaining walls;
- Preparation of this report summarizing our findings, conclusions, and recommendations regarding the above-described information.

2.0 SITE CONDITIONS

The following section describes our findings regarding the site conditions that we observed during our site reconnaissance and subsequent subsurface explorations.



Surface Observations

The project site is located to the east of Oak Dell Drive in Diamond Springs, California and is bounded by an elementary school to the west, a mobile home park to the north, and undeveloped land in the remaining surrounding directions. Topography at the site slopes in varying directions and at varying gradients with a maximum gradient of approximately 2H:1V (Horizontal:Vertical). At the time of our visit on 21 April 2023, the vegetation at the site consisted of seasonal grasses with many scattered trees. Rock outcrops were observed on the southern portion of the site and a sewer lift station is located on the eastern side of the property. Due to heavy rain events prior to our site reconnaissance, portions of the site, particularly on the northern half, were observed to have standing water. Vegetation on the southern half of the site was observed to be pushed over, as if water was recently on the site.

Subsurface Conditions

Our field study included a site reconnaissance by a representative of our firm followed by a subsurface exploration program conducted on 27 June 2023. The exploration program included the excavation of nine exploratory test pits conducted by our representative at the approximate locations shown on Figure A-2, Appendix A.

Subsurface soil conditions were mostly consistent at the locations evaluated and included silty sands or silts underlain by bedrock. In Test Pits TP-8, the upper soil layers were observed to be a soft to medium stiff lean clay to depths of 3 feet. The upper soil layers were generally observed to be medium dense or soft to medium stiff to depths of ½ to 3 feet. Underlying the upper materials is bedrock in a completely to highly weathered condition. For more details on subsurface conditions see Figures A-3 to A-11, Appendix A.

Groundwater Conditions

Due to the shallow depth and low permeability of the underlying rock, perched water is common to the area and could be encountered during grading operations. We did not observe perched water during our recent subsurface exploration program. The presence of perched water can vary because of many factors such as, the proximity to rock, topographic elevations, and the presence of utility trenches. Some evidence of past repeated exposure to subsurface water may include black staining, clay deposits, and surface markings indicating previous seepage. Based on our experience in the area, water may be perched on the bedrock horizon found beneath the site and could vary through the year with higher concentrations during or following precipitation.

3.0 GEOTECHNICAL SOIL CHARACTERISTICS

The geotechnical soil characteristics presented in this section of the report are based on laboratory testing and observation of samples collected from subsurface soils.

Laboratory Testing

Laboratory testing of the collected samples was directed towards determining the physical and engineering properties of the soil underlying the site. The associated test results are presented in Appendix B. In summary, the following tests were performed for the preparation of this report:



Table 1: Laboratory Tests

| Laboratory Test | Test Standard | Summary of Results | |
|----------------------|---------------|--------------------|---|
| Direct Shear | ASTM D3080 | TP-8@1' | $\Phi = 30.5^\circ$, $c = 237$ psf (90%RC) |
| Expansion Index | ASTM D4829 | TP-8@2' | EI = 74 |
| Maximum Dry Density | ASTM D1557 | TP-8@1' | DD = 99.0 pcf, MC = 17.5 % |
| Resistance "R-Value" | CTM 301 | TP-6@1' | R = 50 |

Soil Expansion Potential

The materials encountered in our explorations included plastic materials in the form of a lean clay in Test Pit TP-8, near the proposed gym. Expansion index testing was performed on a sample of the material and resulted in a value of 74, which is considered to be a medium expansion potential. Expansive soils could cause damage to foundations and other rigid improvement if left in place. Depending on the proposed grading plans and cuts or fills in the areas where clay is encountered some focused excavations of the clay may be required if sufficient separation from planned improvements is not achieved. In addition, if during the site preparations operations, the clay soils are determined to be soft and/or unstable under the weight of the construction equipment, they will require overexcavation as discussed in the recommendations section below. If necessary, recommendations can be made based on our observations at the time of construction should greater quantities of expansive soils be encountered at the project site which were not encountered during this study.

4.0 GEOLOGY AND SEISMICITY

The geologic portion of this report includes a review of geologic data pertinent to the site based on an interpretation of our observations of the surface exposures and our observations in our exploratory test pits.

Geologic Conditions

The site is located within the Western Foothills area of the Sierra Nevadan geomorphic province of California. This province is dominated by northwest trending tectonostratigraphic belts of late Paleozoic to Mesozoic metamorphosed sedimentary, volcanic, and intrusive rocks. According to the Geologic Map of the Sacramento Quadrangle, California (Wagner, et al.), the subject property and vicinity are underlain by the Logtown Ridge Formation, the Mariposa Formation, and Mesozoic granitic rocks. The Logtown Ridge formation is a sequence of Late Jurassic mafic volcanic sedimentary rocks and interlayered flows and sills that are north-northwest trending and dip steeply to the east (Duffield & Sharp, 1975). The Mariposa Formation is comprised of black clay slate interbedded with graywacke, conglomerate, and fine-grained mafic tuffaceous rocks and are intruded by porphyritic volcanic rocks or hypabyssal sills (Duffield & Sharp, 1975).

Naturally Occurring Asbestos

Asbestos is classified by the EPA as a known human carcinogen. Naturally occurring asbestos (NOA) has been identified as a potential health hazard. The California Geological Survey published a map in 2018 (Bruijn; August 2018: Open File Report 2000-02 2018 Update) that qualitatively indicates the likelihood for NOA in western El Dorado County. The project site is not identified as being in an NOA review zone based on the published map. Therefore, we do not anticipate that special considerations for NOA will be required during or following grading operations.



Seismicity

Our evaluation of seismicity for the project site included reviewing existing fault maps and obtaining seismic design parameters from the USGS online calculators and databases. For the purpose of this study, we used a latitude and longitude of 38.680937, -120.833405 to identify the project site.

Alquist-Priolo Regulatory Faults

Based upon the records currently available from the California Department of Conservation, the project site is not located within an Alquist-Priolo Regulatory Review Zone and there are no known faults located at the subject site. We do not anticipate special design or construction requirements for faulting at this project site.

Code Based Seismic Criteria

Based upon the subsurface conditions encountered during our study and our experience in the area, the site should be classified as Site Class C. The final choice of design parameters, however, remains the purview of the project structural engineer.

Table 2: Seismic Design Parameters*

| | Reference | Seismic Parameter | Recommended Value |
|-------------------|---|--|-------------------|
| ASCE 7-16 | Table 20.3-1 | Site Class | C |
| | Figure 22-7 | Maximum Considered Earthquake Geometric Mean (MCEC) PGA | 0.181g |
| | Table 11.8-1 | Site Coefficient F_{PGA} | 1.219 |
| | Equation 11.8-1 | $PGA_M = F_{PGA} PGA$ | 0.220g |
| 2022 CBC | Figure 1613.2.1(1) | Short-Period MCE at 0.2s, S_s | 0.425g |
| | Figure 1613.2.1(2) | 1.0s Period MCE, S_1 | 0.205g |
| | Table 1613.2.3(1) | Site Coefficient, F_a | 1.300 |
| | Table 1613.2.3(2) | Site Coefficient, F_v | 1.500 |
| | Equation 16-20 | Adjusted MCE Spectral Response Parameters, $S_{MS} = F_a S_s$ | 0.552g |
| | Equation 16-21 | Adjusted MCE Spectral Response Parameters, $S_{M1} = F_v S_1$ | 0.307g |
| | Equation 16-22 | Design Spectral Acceleration Parameters, $S_{DS} = \frac{2}{3} S_{MS}$ | 0.368g |
| | Equation 16-23 | Design Spectral Acceleration Parameters, $S_{D1} = \frac{2}{3} S_{M1}$ | 0.205g |
| | Table 1613.2.5(1) | Seismic Design Category (Short Period), Occupancy I to III | C |
| | Table 1613.2.5(1) | Seismic Design Category (Short Period), Occupancy IV | D |
| Table 1613.2.5(2) | Seismic Design Category (1-Sec Period), Occupancy I to IV | D | |

*Based on the online calculator available at <https://earthquake.usgs.gov/ws/designmaps/>

Earthquake Induced Liquefaction, Settlement, and Surface Rupture Potential

Liquefaction is the sudden loss of soil shear strength and sudden increase in porewater pressure caused by shear strains, as could result from an earthquake. Research has shown that saturated, loose to medium-dense sands with a silt content less than about 25 percent and located within the top 40 feet are most susceptible to liquefaction and surface rupture/lateral spreading.

Due to the absence of a permanently elevated groundwater table, the relatively low seismicity of the area and the relatively shallow depth to bedrock, the potential for seismically induced damage due to liquefaction, surface ruptures, and settlement is considered low. For the above-mentioned reasons mitigation for these potential hazards is not considered necessary for the development of this project.



Static and Seismically Induced Slope Instability

The existing slopes on the project site were observed to have adequate vegetation on the slope face, appropriate drainage away from the slope face, and no apparent tension cracks or slump blocks in the slope face or at the head of the slope. No other indications of slope instability such as seeps or springs were observed. Additionally, due to the absence of a permanently elevated groundwater table, the relatively low seismicity of the area, and the relatively shallow depth to bedrock, the potential for seismically induced slope instability for the existing slopes is considered low.

5.0 DISCUSSION AND CONCLUSIONS

Based upon the results of our field explorations, findings, and analysis described above, it is our opinion that construction of the proposed improvements is feasible from a geotechnical standpoint, provided the recommendations contained in this report are incorporated into the design plans, specifications, and implemented during construction. The native soils, once processed and compacted as recommended below, may be considered “engineered” and suitable for support of the planned improvements.

Geotechnical Considerations for Development

The project site is generally comprised of a thin layer of sandy soils over shallow bedrock, which is considered suitable for support of the proposed improvements. The expansive clays encountered in the vicinity of the gym are recommended to be over-excavated and moved to a landscape area of the site (i.e. no structural elements) if sufficient separation from foundations or other rigid improvements cannot be achieved based on grading plans.

Generally, issues associated with development on similar sites are associated with the excavation of shallow bedrock and the presence of seepage at the soil to rock contact. Additionally, buildings or structural elements spanning across transition lines (e.g., bedrock to soil, or native soils to engineered fills) may be more prone to differential settlements. The geotechnical recommendations for this project are presented in the following sections.

- This report includes a recommendation for compaction of engineered fills to 90 percent and a minimum of 18 inches of embedment for foundations to reduce the potential for differential settlement. Conventional shallow foundations are expected to provide adequate support for the proposed structures if the site grades are adequately prepared as described in the following sections.
- Given the low lying nature of portions of the site, evidence of standing water and past surface water flows, and the presence of a limiting drainage layer of the shallow bedrock, development areas may be more subject to seepage and poor drainage. Special attention should be given to configuring the landscaping to drain away from improvements or the foundation and how underground utilities are configured to prevent water migrating through the trench becoming impounded against the foundation. The installation of subdrains and back of wall drains should be used to provide increased protection against unwanted water conditions.
- Additional drainage including a subdrain connected to a perimeter drain may be necessary under the turf fields to prevent unwanted water conditions underneath the fields.
- Due to the strength of bedrock, it may be difficult to excavate utilities. Consideration may be given to pre-excavating utility alignments during the mass grading when larger equipment could be used and there is more site access. Some sites with similar shallow rock conditions are developed by overexcavating the rock approximately 2 feet from finish grade during grading to improve landscape performance, and later utility installations.



6.0 SITE GRADING AND EARTHWORK IMPROVEMENTS

Excavation Characteristics

The uppermost site soils are anticipated to be excavatable with conventional earthwork equipment, such as a backhoe or mini-excavator. Excavations will become increasingly difficult with depth due to the underlying bedrock condition and can limit production of backhoes and smaller dozers. Sites with similar subsurface conditions generally resort to using mid-size excavators and larger dozers with single shank rippers.

Where hard rock cuts in fractured rock are proposed, the orientation and direction of excavation/ripping will likely play a large role in the rippability of the material. Blasting cannot be ruled out in areas of resistant rock. When hard rock is encountered, we should be contacted to provide additional recommendations prior to performing an alternative such as blasting. Water inflow into any excavation approaching the hard rock surface is likely to be experienced in all but the driest summer and fall months.

Soil Moisture Considerations

The compaction of soil to a desired relative compaction is dependent on conditioning the soil to a target range of moisture content. Moisture contents that are excessively dry or wet could limit the ability of the contractor to compact soils to the requirements for engineered fill. When dry, moisture should be added to the soil and the soils blended to improve consistency. Wet soil will need to be dried to become compactable. Generally, this includes blending and working the soil to avoid trapping moisture below a dryer surficial crust. Other options are available to reduce the time involved but typically have higher costs and require more evaluation prior to implementation.

The largest contributor to excessive soil moisture is generally precipitation and seepage during the rainy season. In recognition of this, we suggest that consideration be given to the seasonal limitations and costs of winter grading operations on the site. Special attention should be given regarding the drainage of the project site. If the project is expected to work through the wet season, the contractor should install appropriate temporary drainage systems at the construction site and should minimize traffic over exposed subgrades due to the moisture-sensitive nature of the on-site soils. During wet weather operations, the soil should be graded to drain and should be sealed by rubber tire rolling to minimize water infiltration.

Site Preparation

Preparation of the project site should involve site drainage controls, dust control, clearing and stripping, overexcavation and recompaction of loose native soils, and exposed grade compaction considerations. The following paragraphs state our geotechnical comments and recommendations concerning site preparation.

Site Drainage Controls

We recommend that initial site preparation involve intercepting and diverting any potential sources of surface or near-surface water within the construction zones. Because the selection of an appropriate drainage system will depend on the water quantity, season, weather conditions, construction sequence, and methods used by the contractor, final decisions regarding drainage systems are best made in the field at the time of construction. All drainage and/or water diversion performed for the site should be in accordance with the Clean Water Act and applicable Storm Water Pollution Prevention Plan.



Dust Control

Dust control provisions should be provided for as required by the local jurisdiction's grading ordinance (i.e., water truck or other adequate water supply during grading). Dust control is the purview of the grading contractor.

Clearing and Stripping of Organic Materials

Clearing and stripping operations should include the removal of all organic laden materials including trees, bushes, root balls, root systems, and any soft or loose soil generated by the removal operations. Short or mowed dry grasses may be pulverized and lost within fill materials provided no concentrated pockets of organics result. It is the responsibility of the grading contractor to remove excess organics from the fill materials. **No more than 2 percent of organic material, by weight, should be allowed within the fill materials at any given location.** Preserved trees may require tree root protection which should be addressed on an individual basis by a qualified arborist.

Our recommendations are based on limited windows into the surface and interpretations thereof; therefore, a representative of our firm should be present during site clearing operations to identify the location and depth of potential fills or loose soils, some of which may not have been found during our evaluation. We should also be present to observe removal of deleterious materials, and to identify any existing site conditions which may require mitigation or further recommendations prior to site development.

Overexcavation and Recomposition of Loose Native Soils

Following general site clearing, all existing loose or saturated native soils within the development footprint should be overexcavated down to firm native materials and backfilled with engineered fill as detailed in the engineered fill section below. Any depressions extending below final grade resulting from the removal of fill materials or other deleterious materials should be properly prepared as discussed below and backfilled with engineered fill.

Overexcavation of Clay Soils In Improvement Areas

A review of the site grading plan will be required to determine the separation of the proposed improvement from anticipated clays. We recommend that a minimum of 3 feet of non-expansive soils be present under building foundations, and 1.5 feet of non-expansive soils present under flatwork or slabs on grade. We recommend that overexcavations extend laterally at least 5 feet beyond the proposed improvements. The native sands or select import soils, compacted as engineered fills, would be appropriate backfill materials to achieve the non-expansive soil recommendations. Bulk gravel fills are not recommended.

Exposed Grade Compaction

Exposed soil grades, following initial site preparation activities and overexcavation operations, should be scarified to a minimum depth of 8 inches and compacted to the requirements for engineered fill. Generally, where bedrock conditions are exposed, no scarification should be necessary; however, these surfaces should be moisture conditioned and compacted to mitigate disturbance resulting from site preparation. Prior to placing fill, the exposed grades should be in a firm and unyielding state. Any localized zones of soft or pumping soils observed within the exposed grade should either be scarified and recompacted or be overexcavated and replaced with engineered fill as detailed in the engineered fill section below.

Engineered Fill Criteria

All materials placed as fills on the site should be placed as "Engineered Fill" which is observed, tested, and compacted as described in the following paragraphs.



Suitability of Onsite Materials

We expect that soil generated from excavations on the site, excluding deleterious material, may be used as engineered fill provided the material does not exceed 8 inches in maximum dimension. The contractor should either dispose of the excess oversized materials to an offsite location or mechanically reduce the rock to less than 8 inches. The soil/rock mixture should be thoroughly mixed so as to preclude nesting or the formation of voids.

Fill Placement and Compaction

Engineered fills should be placed in thin horizontal lifts not to exceed 8 inches in uncompacted thickness. If the contractor can achieve the recommended relative compaction using thicker lifts, the method may be judged acceptable based on field verification by a representative of our firm using standard density testing procedures. Lightweight compaction equipment may require thinner lifts to achieve the recommended relative compaction. Fills should have a maximum particle size of 8 inches unless approved by our firm.

The relative compaction of engineered fills is based on the maximum density and optimum moisture determined through the ASTM D1557 test method. We have considered the potential for differential settlement for this site and recommend that the engineered fills be placed at a relative compaction of 90 percent. Depending on the moisture condition of the soils, the engineered fills may require moisture conditioning to be within a suitable compaction range.

Our firm should be requested for consultation, observation, and testing for the earthwork operations prior to the placement of any fills. Fill soil compaction should be evaluated by means of in-place density tests performed during fill placement so that adequacy of soil compaction efforts may be determined as earthwork progresses. Should conventional testing methods not be achievable due to high rock content within the fill, a method specification should be provided by our firm at the time of construction.

Import Materials

The recommendations presented in this report are based on the assumption that the import materials will be similar to the materials present at the project site. High quality materials are preferred for import; however, these materials can be more dependent on source availability. Import material should be approved by our firm prior to transporting it to the project site.

Material for this project should consist of a material with the geotechnical characteristics presented below. If these requirements are not met, additional testing and evaluation may be necessary to determine the appropriate design parameters for foundations, pavement, and other improvements.

Table 3: Select Import Criteria

| Behavior Property | Reference Document | Recommendation |
|--------------------------|---------------------------|---|
| Direct Shear Strength | ASTM D3080 | ≥ 30° when compacted |
| Plasticity Index | ASTM D4318 | ≤ 12 |
| Expansion Index | ASTM D4829 | ≤ 20 |
| Sieve Analysis | ASTM D1140 | Not more than 30% Passing the No. 200 sieve |
| Maximum Aggregate Size | ASTM D1140 | ≤ 6" |



Slope Configuration and Grading

The project site is proposed to have cuts and fill with a maximum slope orientation of 2H:1V (Horizontal:Vertical). Generally, a cut slope orientation of 2H:1V is considered stable with the material types encountered on the site. A fill slope constructed at the same orientation is considered stable if compacted to the engineered fill recommendations as stated in the recommendations section of this report. All slopes should have appropriate drainage and vegetation measures to minimize erosion of slope soils.

Placement of Fills on Slopes

Placement of fill material on natural slopes should be stabilized by means of keyways and benches. Where the slope of the original ground equals or exceeds 5H:1V, a keyway should be constructed at the base of the fill. The keyway should consist of a trench excavated to a depth of at least 2 feet into firm, competent materials. The keyway trench should be at least 10 feet wide or as designated by our firm based on the conditions at the time of construction. Benches should be cut into the original slope as the filling operation proceeds. Each bench should consist of a level surface excavated at least 6 feet horizontally into firm soils or 4 feet horizontally into rock. The rise between successive benches should not exceed 36 inches. The need for subdrainage should be evaluated at the time of construction. Refer to Figure C-1 in Appendix C for typical keyway and bench construction.

Slope Face Compaction

All slope fills should be laterally overbuilt and cut back such that the required compaction is achieved at the proposed finish slope face. As a less preferable alternative, the slope face could be track walked or compacted with a wheel. If this second alternative is used, additional slope maintenance may be necessary.

Slope Drainage

Surface drainage should not be allowed to flow uncontrolled over any slope face. Adequate surface drainage control should be designed by the project civil engineer in accordance with the latest applicable edition of the CBC. All slopes should have appropriate drainage and vegetation measures to minimize erosion of slope soils.

7.0 DESIGN RECOMMENDATIONS

The contents of this section include recommendations for foundations, slabs-on-grade, retaining walls, pavements, and drainage.

Shallow Conventional Foundations

Shallow conventional foundation systems are considered suitable for construction of the planned improvements, provided that the site is prepared in accordance with the recommendations discussed in Section 6.0 of this report.

The provided values do not constitute a structural design of foundations which should be performed by the structural engineer. In addition to the provided recommendations, foundation design and construction should conform to applicable sections of the 2022 California Building Code.

Foundation Capacities

The foundation bearing and lateral capacities are presented in the table below. The allowable bearing capacity is for support of dead plus live loads based on the foundation configuration presented in this report. The allowable capacity may be increased by 1/3 for short-term wind and seismic loads. Lateral forces on structures may be resisted by passive pressure acting against



the sides of shallow footings and/or friction between the foundation bearing material and the bottom of the footing. Section 1806.3 of the 2022 CBC allows for the combination of the friction factor and passive resistance value to lateral resistance. Consideration should be given to ignoring passive resistance where soils could be disturbed later or within 6 feet horizontally of the slope face.

Table 4: Foundation Capacities

| Soil Type | Design Condition | Design Value | Applied Factor of Safety |
|---|------------------------------|--------------|--------------------------|
| Engineered Fill or Firm Native Soil | Allowable Bearing Capacity | 2,300 psf | 3.0 |
| | Allowable Friction Factor* | 0.4 | 1.5 |
| | Allowable Passive Resistance | 250 psf/ft | 1.5 |
| Bedrock | Allowable Bearing Capacity | 4,000 psf | 3.0 |
| | Allowable Friction Factor* | 0.50 | 1.5 |
| | Allowable Passive Resistance | 400 psf/ft | 1.5 |
| * Friction Factor is calculated as $\tan(\phi)$ | | | |

Foundation Settlement

A total settlement of less than 1 inch is anticipated; a differential settlement of 0.5 inches in 25 feet is anticipated where foundations are bearing on like materials. The settlement criteria are based upon the assumption that foundations will be sized and loaded in accordance with the recommendations in this report.

Foundation Configuration

Conventional shallow foundations should be a minimum of 12 inches wide and founded a minimum of 18 inches below the lowest adjacent soil grade. Isolated pad foundations should be a minimum of 24 inches in plan dimension.

Foundation reinforcement should be provided by the structural engineer. The reinforcement schedule should account for typical construction issues such as load consideration, concrete cracking, and the presence of isolated irregularities. At a minimum, we recommend that continuous footing foundations be reinforced with four No. 4 reinforcing bars, two located near the bottom of the footing and two near the top of the stem wall.

Foundation Influence Line and Slope Setback

All footings should be founded below an imaginary 2H:1V plane projected up from the bottoms of adjacent footings and/or parallel utility trenches, or to a depth that achieves a minimum horizontal clearance of 6 feet from the outside toe of the footings to the slope face, whichever requires a deeper excavation.

Subgrade Conditions

Footings should never be cast atop soft, loose, organic, slough, debris, nor atop subgrades covered by ice or standing water. A representative of our firm should be retained to observe all subgrades during footing excavations and prior to concrete placement so that a determination as to the adequacy of subgrade preparation can be made.

Shallow Footing / Stemwall Backfill

All footing/stemwall backfill soil should be compacted to the criteria for engineered fill as recommended in Section 6.0 of this report.



Deep Foundations

We anticipate that the proposed field lights may be supported using a cast-in-drilled-hole (CIDH) pile. Based on other soccer field projects, we anticipate that the foundations may be roughly 15 feet deep and 30 inch diameter. Actual weights and dimensions of the light standards may be different from the anticipated condition and could result in the need for different pile diameters and depths. The pile designer should evaluate the conditions and prepare a design appropriate to their needs. Discussions regarding geotechnical elements, including the soil profile, design capacities, and settlement are provided below.

Axial Capacities

The piles may be constructed based on end bearing capacities. An end bearing capacity of 2,300 psf for engineered fill soils or 4,000 psf into weathered bedrock fill materials may be utilized for the design of the piles. If the design utilizes skin friction in the calculations, the friction values can be utilized as 1/6 of the end bearing value.

Uplift Capacity

We recommend that the uplift capacity of a single pile be limited to the self-weight of the pile or ½ of the skin friction.

Lateral Capacity of Piles

Piles with lengths of 6 pile diameters (6D) or less may be designed as rigid elements. Lateral forces on structures for this condition may be resisted by passive pressure acting against the sides of piles. A passive resistance of 400 pcf equivalent fluid weight may be used against the side of piles in shallow weathered bedrock conditions and 250 pcf in engineered fill soils. If a deflection of ½ inch is acceptable for the performance of the structure, the value may be doubled to not greater than 500 pcf.

Estimated Settlement

The piles, constructed as recommended above are anticipated to have negligible settlement. Cleaning of the hole with a cleaning bucket is recommended for use to minimize settlements and provide anticipated capacities.

The site has a negligible potential for liquefaction settlement and no significant changes to generate downdrag; therefore, downdrag of the pile is not expected to impact this project.

Construction Considerations

Precautions should be taken during pile excavations to reduce caving and raveling. The following recommendations are presented and should be followed where applicable.

- A cleaning bucket should be used to clean the bottom of the hole when end-bearing designs are used.
- Piles should be installed under the full-time observation of our firm.
- Pile excavations should be filled with concrete as soon as possible following drilling. Pile excavations should not be left open for extended periods of time.
- In the event of soil caving or water seepage into the pile excavation, casing should be used. Casing may be pulled as the pile excavation is filled with concrete. The use of “wet” construction, such as “super-mud” is not recommended.
- Concrete should be placed and vibrated throughout the full length of the pile so that voids do not exist in either the pile base or the shaft. Placement procedures, such as tremie, should be used so that the concrete is not allowed to fall freely more than 5 feet and to prevent concrete from striking the walls of the excavations and possibly causing caving.



- Where the drilling operation might affect the concrete in an adjacent pile (i.e. where pile spacing is less than 3 diameters), drilling should not be carried out before the previously poured pile concrete has set for at least 24 hours, or as permitted by our firm at the time of construction.

Our firm should be afforded the opportunity to review the project grading and foundation plans to confirm the applicability of the recommendations provided in this report. Modifications to these recommendations may be made at the time of our review.

Slab-on-Grade Construction

It is our opinion that soil-supported slab-on-grade floors could be used for the main floor of the structure, contingent on proper subgrade preparation. Often the geotechnical issues regarding the use of slab-on-grade floors include proper soil support and subgrade preparation, proper transfer of loads through the slab underlayment materials to the subgrade soils, and the anticipated presence or absence of moisture at or above the subgrade level. We offer the following comments and recommendations concerning support of slab-on-grade floors. The slab design (concrete mix design, curing procedures, reinforcement, joint spacing, moisture protection, and underlayment materials) is the purview of the project Structural Engineer.

Slab Subgrade Preparation

All subgrades proposed to support slab-on-grade floors should be prepared and compacted to the requirements of engineered fill as discussed in Section 6.0 of this report.

Slab Underlayment

As a minimum for slab support conditions, the slab should be underlain by a minimum 4-inch-thick crushed rock layer that is covered by a minimum 10-mil thick moisture retarding plastic membrane. The membrane may only be functional when it is above the vapor sources. The bottom of the crushed rock layer should be above the exterior grade to act as a capillary break and not a reservoir, unless it is provided with an underdrain system. The slab design and underlayment should be in accordance with ASTM E1643 and E1745.

An optional 1-inch blotter sand layer placed above the plastic membrane, is sometimes used to aid in curing of the concrete. Although historically common, this blotter layer is not currently included in slabs designed according to the 2022 Green Building Code. When omitted, special wet curing procedures will be necessary. If installed, the blotter layer can become a reservoir for excessive moisture if inclement weather occurs prior to pouring the slab, excessive water collects in it from the concrete pour, or an external source of water enters above or bypasses the membrane.

Our experience has shown that vapor transmission through concrete is controlled through proper concrete mix design. As such, proper control of moisture vapor transmission should be considered in the design of the slab as provided by the project architect, structural or civil engineer. It should be noted that placement of the recommended plastic membrane, proper mix design, and proper slab underlayment and detailing per ASTM E1643 and E1745 will not provide a waterproof condition. If a waterproof condition is desired, we recommend that a waterproofing expert be consulted for slab design.

Slab Thickness and Reinforcement

Geotechnical reports have historically provided minimums for slab thickness and reinforcement for general crack control. The concrete mix design and construction practices can additionally have a large impact on concrete crack control. All concrete should be anticipated to crack. As such, these minimums should not be considered to be standalone items to address crack control, but are suggested to be considered in the slab design methodology.



In order to help control the growth of cracks in interior concrete from becoming significant, we suggest the following minimums. Interior concrete slabs-on-grade not subject to heavy loads, should be a minimum of 4-inches thick and reinforced. A minimum of No. 3 deformed reinforcing bars placed at 18 inches on center both ways, at the center of the structural section is suggested. Joint spacing should be provided by the structural engineer. Troweled joints recovered with paste during finishing or “wet sawn” joints should be considered every 10 feet on center. Expansion joint felt should be provided to separate floating slabs from foundations and at least at every third joint. Cracks will tend to occur at recurrent corners, curved or triangular areas and at points of fixity. Trim bars can be utilized at right angle to the predicted crack extending 40 bar diameters past the predicted crack on each side.

Vertical Deflections

Soil-supported slab-on-grade floors can deflect downward when vertical loads are applied, due to elastic compression of the subgrade. For preliminary design of concrete floors, a modulus of subgrade reaction of $k = 190$ psi per inch would be applicable for engineered fills.

Exterior Flatwork

Exterior concrete flatwork is recommended to have a 4-inch-thick rock cushion. This could consist of vibroplate compacted crushed rock or compacted $\frac{3}{4}$ -inch aggregate baserock. If exterior flatwork concrete is against the floor slab edge without a moisture separator it may transfer moisture to the floor slab. Expansion joint felt should be provided to separate exterior flatwork from foundations and at least at every third joint. Contraction / groove joints should be provided to a depth of at least $\frac{1}{4}$ of the slab thickness and at a spacing of less than 30 times the slab thickness for unreinforced flatwork, dividing the slab into nearly square sections. Cracks will tend to occur at recurrent corners, curved or triangular areas and at points of fixity. Trim bars can be utilized at right angle to the predicted crack extending 40 bar diameters past the predicted crack on each side.

Retaining Walls

Our design recommendations and comments regarding retaining walls for the project site are discussed below. *Retaining wall foundations should be designed in accordance with the Shallow Conventional Foundations section above. **The following parameters are based on native sand and gravel backfills, or select import backfill. Native clays are not recommended to be present within the backfill zones or within 3 feet of foundation elements.***

Retaining Wall Lateral Pressures

Based on our observations and testing, the retaining wall should be designed to resist lateral pressure exerted from a soil media having an equivalent fluid weight provided in the table below. The values presented below are not factored and are for conditions when firm native soil or engineered fill is used within the zone behind the wall defined as twice the height of the retaining wall. Additionally, the values do not account for the friction of the backfill on the retaining wall which may or may not be present depending on the wall materials and construction.

The lateral pressures presented in the table below include recommendations for earthquake loading which is required for structures to be designed in Seismic Design Categories D, E, or F per Section 1803.5.12 of the 2022 California Building Code. The lateral pressures presented have been calculated using the Mononobe-Okabe Method derived from Wood (1973) and modified by Whitman et al. (1991). The values are intended to be used as the multiplier for uniformly distributed loads and the parameter “H” is the total height of the wall including the footing but excluding any key, if used.



Table 5: Retaining Wall Pressures

| Wall Type | Wall Slope Configuration | Equivalent Fluid Weight (pcf) | Lateral Pressure Coefficient | Earthquake Loading (plf) | |
|-----------------|--------------------------|-------------------------------|------------------------------|--------------------------|---|
| Free Cantilever | Flat | 34 | 0.28 | 3H ² | Applied 0.6H above the base of the wall |
| | 3H:1V | 42 | 0.35 | 13H ² | |
| | 2H:1V | 50 | 0.42 | | |
| Restrained* | Flat | 53 | 0.44 | | |

* Restrained conditions shall be defined as walls which are structurally connected to prevent flexible yielding, or rigid wall configurations (i.e., walls with numerous turning points) which prevent the yielding necessary to reduce the driving pressures from an at-rest state to an active state.

Design Values for Dry Stacked Walls

Dry stacked walls do not generally use the equivalent fluid weight method presented above; instead, they use design soil properties for a given soil condition such as the internal friction angle, cohesion, and bulk unit weight. The walls could include keyed or interlocking non-mortared walls such as segmental block (Basalite, Keystone, Allan Block, etc.), rockery walls, or specialty designs for proprietary systems. When this occurs, the following soil parameters would be applicable for design with the onsite native materials in a firm condition or for engineered fills. The seismic coefficient is considered to be ½ of the adjusted peak ground acceleration for the site conditions is given in Section 4.0 of this report. Some software allows for the extension of the Mononobe-Okabe Method beyond the conventional limitations and, if the method is applied, could calculate seismic values significantly higher than those provided by the multiplier method provided above.

Table 6: Generalized Design Parameters

| Internal Angle of Friction | Cohesion | Bulk Unit Weight | Seismic Coefficient, Kh |
|----------------------------|----------|------------------|-------------------------|
| 34° | 0 psf | 120 pcf | 0.110g |

Wall Drainage

The criteria presented above is based on fully drained conditions as detailed in the attached Figure C-2, Appendix C. For these conditions, we recommend that a blanket of filter material be placed behind all proposed walls. Permeable materials are specified in Section 68 of the California Department of Transportation Standard Specifications, current edition. The filter material should conform to Class 1, Type B permeable material in combination with a filter fabric to separate the open graded gravel/rock from the surrounding soils. Generally, a clean ¾ inch crushed rock should be acceptable. Consistent with Caltrans Standards, when Class 2 permeable materials are used, the filter fabric may be omitted unless otherwise designed.

The blanket of filter material should be a minimum of 12-inches thick and should extend from the bottom of the wall to within 12 inches of the ground surface. The top 12 inches of wall backfill should consist of a compacted soil cap. A filter fabric having specifications equal to or greater than those for Mirafi 140N should be placed between the gravel filter material and the surrounding soils to reduce the potential for infiltration of soil into the gravel. A 4-inch diameter drain pipe should be installed near the bottom of the filter blanket with perforations facing down. The drainpipe should be underlain by at least 4 inches of filter-type material. An adequate gradient should be provided along the top of the foundation to discharge water that collects behind the retaining wall to a controlled discharge system.

The configuration of a long retaining wall generally does not allow for a positive drainage gradient within the perforated drain pipe behind the wall since the wall footing is generally flat with no gradient for drainage. Where this condition is present, to maintain a positive drainage behind the



walls, we recommend that the wall drains be provided with a discharge to an appropriate non-erosive outlet a maximum of 50 feet on center. **In addition, if the wall drain outlets are temporarily stubbed out in front of the walls for future connection during building construction, it is imperative that the outlets be routed into the tight pipe area drainage system and not buried and rendered ineffective.**

Asphalt Concrete Pavement Design

We understand that asphalt pavements will be used for the associated roadways and parking areas. The following comments and recommendations are given for pavement design and construction purposes. All pavement construction and materials used should conform to applicable sections of the latest edition of the California Department of Transportation Standard Specifications.

Relative Compaction

The asphalt concrete pavement section should be constructed to achieve the minimum relative compactions specified in Section 6.0 of this report. Deviation from the following table should be reviewed by the governing agency when the pavements are to be constructed within their right-of-way. Final acceptance of the constructed pavement section is the purview of the governing agency or owner of the site.

Subgrade Stability

All subgrades and aggregate base should be proof-rolled with a full water truck or equivalent immediately before paving, in order to evaluate their condition. If unstable subgrade conditions are observed, these areas should be overexcavated down to firm materials and the resulting excavation backfilled with suitable materials for compaction (i.e., drier native soils or aggregate base). Areas displaying significant instability may require geotextile stabilization fabric within the overexcavated area, followed by placement of aggregate base. Final determination of any required overexcavation depth and stabilization fabric should be based on the conditions observed during subgrade preparation.

Subgrade Resistance Value

Critical features that govern the durability of a pavement section include the stability of the subgrade; the presence or absence of moisture, free water, and organics; the fines content of the subgrade soils; the traffic volume; and the frequency of use by heavy vehicles. Soil conditions can be defined by a soil resistance value, or "R-Value," and traffic conditions can be defined by a Traffic Index (TI).

Laboratory testing was performed on a bulk sample considered to be representative of the materials expected to be exposed at subgrade. The tested soil had an R-Value of 50. We used an R-Value of 40 for our designs to account for some variability that may occur following grading operations.

Design values provided are based upon properly drained subgrade conditions. Although the R-Value design to some degree accounts for wet soil conditions, proper surface and landscape drainage design is integral in performance of adjacent street sections with respect to stability and degradation of the asphalt. Due to the redistribution of materials that occurs during grading operations, we should review pavement subgrades to determine the appropriateness of the provided sections, and provide additional pavement design recommendations as field conditions dictate.



Section Thickness

The recommended design thicknesses presented in the following table were calculated in accordance with the methods presented in the Sixth Edition of the California Department of Transportation Highway Design Manual. A varying range of traffic indices are provided for use by the project Civil Engineer for roadway design.

Table 7: Asphalt Pavement Section Recommendations

| Design Traffic Indices | Alternative Pavement Sections (Inches) | |
|------------------------|--|-------------------|
| | Asphalt Concrete * | Aggregate Base ** |
| 4.5 | 2.5 | 4.0 |
| | 3.0 | 4.0 |
| 5.0 | 2.5 | 5.0 |
| | 3.0 | 4.0 |
| 5.5 | 3.0 | 5.0 |
| | 3.5 | 4.0 |
| 6.0 | 3.0 | 6.5 |
| | 3.5 | 5.5 |

* Asphalt Concrete: must meet specifications for Caltrans Hot Mix Asphalt Concrete

** Aggregate Base: must meet specifications for Caltrans Class II Aggregate Base (R-Value = minimum 78)

Portland Cement Concrete Pavement Design

We understand that Portland cement concrete pavements may be considered for various aspects of the project. The American Concrete Institute (ACI) Concrete Pavement Design method (ACI 330R-08) was used for design of the exterior concrete (rigid) pavements at the site.

Relative Compaction

The asphalt concrete pavement section should be constructed to achieve the minimum relative compactions specified in Section 6.0 of this report. Deviation from the following table should be reviewed by the governing agency when the pavements are to be constructed within their right-of-way. Final acceptance of the constructed pavement section is the purview of the governing agency.

Subgrade Stability

All subgrades and aggregate base should be proof-rolled with a full water truck or equivalent immediately before paving, in order to evaluate their condition.

Soil Design Parameters

The pavement thicknesses were evaluated based on the soil design parameters provided in the following table.

Table 8: Soil Parameters

| Subgrade Soil Description | k, Modulus of Subgrade Reaction* | Base Course |
|---------------------------|----------------------------------|-------------|
| Silt with Sand | 190 pci | 4 inches |

* Based on an R-Value of 40 as recommended above and correlated to a k-Value recommended by ACI 330R.

Section Thickness

Based on the subgrade soil parameters shown in the above table, the recommended concrete thicknesses for various traffic descriptions are presented in the table below. The recommended thicknesses provided below assume the use of plain (non-reinforced) concrete pavements.



Table 9: Concrete Pavement Section Recommendations

| Category | ADTT* | Pavement Traffic Description | Thickness (inches) | |
|----------|-------|--|--------------------|------------|
| | | | 3000 psi** | 4000 psi** |
| A | 1 | Car parking areas and access lanes Autos, pickups, and panel trucks only | 4.5 | 4.5 |
| A | 10 | | 5.0 | 5.0 |
| B | 25 | Shopping center entrance and service lanes Bus parking areas and interior lanes Single-unit truck parking areas and interior lanes | 6.0 | 5.5 |
| B | 300 | | 6.5 | 6.0 |
| C | 100 | Roadway Entrances and Exterior Lanes | 7.0 | 6.5 |
| C | 300 | | 7.0 | 7.0 |
| C | 700 | | 8.0 | 8.0 |

* Average Daily Truck Traffic

** 28-day concrete compressive strength

Jointing and Reinforcement

From a geotechnical perspective, contraction joints should be placed in accordance with the American Concrete Institute (ACI) recommendations which include providing a joint spacing about 30 times the slab thickness up to a maximum of 10 feet. The joint patterns should also divide the slab into nearly square panels. If increased joint spacing is desired, reinforcing steel should be installed within the pavement in accordance with ACI recommendations. Final determination of steel reinforcement configurations (if used within the pavements) remains the purview of the Project Structural Engineer.

Drainage

In order to maintain the engineering strength characteristics of the soil presented for use in this report, maintenance of the site will need to be performed. This maintenance generally includes, but is not limited to, proper drainage and control of surface and subsurface water which could affect structural support and fill integrity. A difficulty exists in determining which areas are prone to the negative impacts resulting from high moisture conditions due to the diverse nature of potential sources of water; some of which are outlined in the paragraph below. We suggest that measures be installed to minimize exposure to the adverse effects of moisture, but this will not guarantee that excessive moisture conditions will not affect the structure.

Some of the diverse sources of moisture could include water from landscape irrigation, annual rainfall, offsite construction activities, runoff from impermeable surfaces, collected and channeled water, and water perched in the subsurface soils. Some of these sources can be controlled through drainage features installed either by the owner or contractor. Others may not become evident until they, or the effects of the presence of excessive moisture, are visually observed on the property.

Some measures that can be employed to minimize the buildup of moisture include, but are not limited to proper backfill materials and compaction of utility trenches within the footprint of the proposed structures; grout plugs at foundation penetrations; collection and channeling of drained water from impermeable surfaces (i.e. roofs, concrete or asphalt paved areas); installation of subdrain/cut-off drain provisions; utilization of low flow irrigation systems; proper design and maintenance of landscaping and drainage facilities.



Drainage Adjacent to Buildings

All grades should provide rapid removal of surface water runoff; ponding water should not be allowed on building pads or adjacent to foundations or other structural improvements (during and following construction). All soils placed against foundations during finish grading should be compacted to minimize water infiltration. Finish and landscape grading should include positive drainage away from all foundations. Section 1808.7.4 of the 2022 California Building Code (CBC) states that for graded soil sites, the top of any exterior foundation shall extend above the elevation of the street gutter at the point of discharge or the inlet of an approved drainage device a minimum of 12 inches plus 2 percent. If overland flow is not achieved adjacent to buildings, the drainage device should be designed to accept flows from a 100-year event. Grades directly adjacent to foundations should be no closer than 8 inches from the top of the slab (CBC 2304.12.1.2), and weep screeds are to be placed a minimum of 4 inches clear of soil grades and 2 inches clear of concrete or other hard surfacing (CBC 2512.1.2). From this point, surface grades should slope a minimum of 2 percent away from all foundations for at least 5 feet but preferably 10 feet, and then 2 percent along a drainage swale to the outlet (CBC 1804.4). Downspouts should be tight piped via an area drain network and discharged to an appropriate non-erosive outlet away from all foundations.

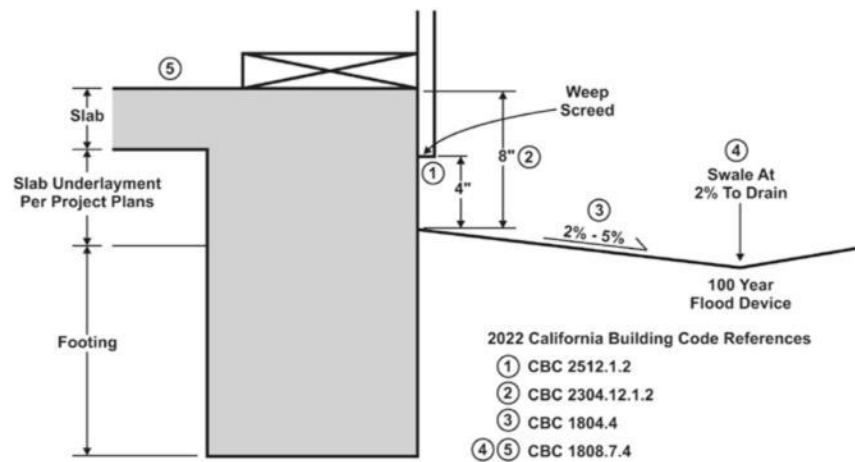

**Typical 2022 California Building Code
 Drainage Requirements**

The above referenced elements pertaining to drainage of the proposed structures is provided as general acknowledgement of the California Building Code requirements, restated and graphically illustrated for ease of understanding. Surface drainage design is the purview of the Project Architect/Civil Engineer. Review of drainage design and implementation adjacent to the building envelopes is recommended as performance of these improvements is crucial to the performance of the foundation and construction of rigid improvements.

Subdrainage

Reduction of potential moisture related issues could be addressed by the construction of subdrains in addition to the drainage provisions provided in the 2022 CBC. Typical subdrain construction would include a 3 feet deep trench (or depth required to intercept the bottom of utility trenches) constructed as detailed on Figure C-3, Appendix C. The water collected in the subdrain pipe would be directed to an appropriate non-erosive outlet. We recommend that a representative from our firm be present during the subdrain installation procedures to document that the drain is installed in accordance with the observed field conditions, as well as to provide additional consultation as the conditions dictate.



Post Construction

All drainage related issues may not become known until after construction and landscaping are complete. Therefore, some mitigation measures may be necessary following site development. Given the soil conditions on site, excessive or even normal landscape watering could contribute to moisture related problems and/or cause distress to foundations and slabs, pavements, and underground utilities, as well as creating a nuisance where seepage occurs.

Low Impact Development Standards

Low Impact Development or LID standards have become a consideration for many projects in the region. LID standards are intended to address and mitigate urban storm water quality concerns. These methods include the use of Source Controls, Run-off Reduction and Treatment Controls. For the purpose of this report use of Run-off Reduction measures and some Treatment Controls may impact geotechnical recommendations for the project.

Youngdahl Consulting Group, Inc. did not perform any percolation or infiltration testing for the site as part of the Geotechnical Investigation. A review of soil survey and the data collected from test pits indicate that soils within the project are Hydrologic Soil Group C (low permeability). Based on this condition, use of infiltration type LID methods (infiltration trenches, dry wells, infiltration basins, permeable pavements, etc.) should not be considered without addressing applicable geotechnical considerations/implications. As such, use of any LID measure that would require infiltration of discharge water to surfaces adjacent to structures/pavement or include infiltration type measures should be reviewed by Youngdahl Consulting Group, Inc. during the design process.

8.0 DESIGN REVIEW AND CONSTRUCTION MONITORING

Geotechnical engineering can be affected by natural variability of soils and, as with many projects, the contents of this report could be used and interpreted by many design professionals for the application and development of their plans. For these reasons, we recommend that our firm provide support through plan reviews and construction monitoring to aid in the production of a successful project.

Plan Review

The design plans and specifications should be reviewed and accepted by Youngdahl Consulting Group, Inc. prior to contract bidding. A review should be performed to determine whether the recommendations contained within this report are still applicable and/or are properly interpreted and incorporated into the project plans and specifications. Modifications to the recommendations provided in this report or to the design may be necessary at the time of our review based on the proposed plans.

Construction Monitoring

Construction monitoring is a continuation of geotechnical engineering to confirm or enhance the findings and recommendations provided in this report. It is essential that our representative be involved with all grading activities in order for us to provide supplemental recommendations as field conditions dictate. Youngdahl Consulting Group, Inc. should be notified at least two working days before site clearing or grading operations commence, and should observe the stripping of deleterious material, overexcavation of soft soil/clays as applicable and existing fills (if present), and provide consultation, observation, and testing services to the grading contractor in the field. At a minimum, Youngdahl Consulting Group, Inc. should be retained to provide services listed in Table 10 below.



The recommendations included in this report have been based in part on assumptions about strata variations that may be tested only during earthwork. Accordingly, these recommendations should not be applied in the field unless Youngdahl Consulting Group, Inc. is retained to perform construction observation and thereby provide a complete professional geotechnical engineering service through the observational method. Youngdahl Consulting Group, Inc. cannot assume responsibility or liability for the adequacy of its recommendations when they are used in the field without Youngdahl Consulting Group, Inc. being retained to observe construction.

Post Construction Drainage Monitoring

Due to the elusive nature of subsurface water, the alteration of water features for development, and the introduction of new water sources, all drainage related issues may not become known until after construction and landscaping are complete. Youngdahl Consulting Group, Inc. can provide consultation services upon request that relate to proper design and installation of drainage features during and following site development.

9.0 LIMITATIONS AND UNIFORMITY OF CONDITIONS

1. This report has been prepared for the exclusive use of the addressee of this report for specific application to this project. The addressee may provide their consultants authorized use of this report. Youngdahl Consulting Group, Inc. has endeavored to comply with generally accepted geotechnical engineering practice common to the local area. Youngdahl Consulting Group, Inc. makes no other warranty, expressed or implied.
2. As of the present date, the findings of this report are valid for the property studied. With the passage of time, changes in the conditions of a property can occur whether they be due to natural processes or to the works of man on this or adjacent properties. Legislation or the broadening of knowledge may result in changes in applicable standards. Changes outside of our control may cause this report to be invalid, wholly or partially. Therefore, this report should not be relied upon after a period of three years without our review nor should it be used or is it applicable for any properties other than those studied.
3. Section [A] 107.3.4 of the 2022 California Building Code states that, in regard to the design professional in responsible charge, the building official shall be notified in writing by the owner if the registered design professional in responsible charge is changed or is unable to continue to perform the duties.

WARNING: Do not apply any of this report's conclusions or recommendations if the nature, design, or location of the facilities is changed. If changes are contemplated, Youngdahl Consulting Group, Inc. must review them to assess their impact on this report's applicability. Also note that Youngdahl Consulting Group, Inc. is not responsible for any claims, damages, or liability associated with any other party's interpretation of this report's subsurface data or reuse of this report's subsurface data or engineering analyses without the express written authorization of Youngdahl Consulting Group, Inc.

4. The analyses and recommendations contained in this report are based on limited windows into the subsurface conditions and data obtained from subsurface exploration. The methods used indicate subsurface conditions only at the specific locations where samples were obtained, only at the time they were obtained, and only to the depths penetrated. Samples cannot be relied on to accurately reflect the strata variations that usually exist between sampling locations. Should any variations or undesirable conditions be encountered during the development of the site, Youngdahl Consulting Group, Inc. will provide supplemental recommendations as dictated by the field conditions.



Table 10: Checklist of Recommended Services

| Item Description | | Recommended | Not Anticipated |
|------------------|--|-------------|-----------------|
| 1 | Provide foundation design parameters | Included | |
| 2 | Review grading plans and specifications | ✓ | |
| 3 | Review foundation plans and specifications | ✓ | |
| 4 | Observe and provide recommendations regarding demolition | | ✓ |
| 5 | Observe and provide recommendations regarding site stripping | ✓ | |
| 6 | Observe and provide recommendations on moisture conditioning removal, and/or recompaction of unsuitable existing soils | ✓ | |
| 7 | Observe and provide recommendations on the installation of subdrain facilities | ✓ | |
| 8 | Observe and provide testing services on fill areas and/or imported fill materials | ✓ | |
| 9 | Review as-graded plans and provide additional foundation recommendations, if necessary | ✓ | |
| 10 | Observe and provide compaction tests on storm drains, water lines and utility trenches | | ✓ |
| 11 | Observe foundation excavations and provide supplemental recommendations, if necessary, prior to placing concrete | ✓ | |
| 12 | Observe and provide moisture conditioning recommendations for foundation areas and slab-on-grade areas prior to placing concrete | | ✓ |
| 13 | Provide design parameters for retaining walls | Included | |
| 14 | Observe the installation of retaining wall drains | ✓ | |
| 15 | Provide finish grading and drainage recommendations | Included | |
| 16 | Provide geologic observations and recommendations for keyway excavations and cut slopes during grading | ✓ | |
| 17 | Excavate and recompact all test pits within structural areas | ✓ | |

APPENDIX A

Field Study

Vicinity Map

Site Plan

Logs of Exploratory Test Pits

Soil Classification Chart and Log Explanation



Introduction

The contents of this appendix shall be integrated with the Geotechnical Engineering Study of which it is a part. They shall not be used in whole or in part as a sole source for information or recommendations regarding the subject site.

Our field study included a site reconnaissance by a Youngdahl Consulting Group, Inc. representative followed by a subsurface exploration program conducted on 27 June 2023, which included the excavation of nine test pits under her direction at the approximate locations shown on Figure A-2, this Appendix. Excavation of the test pits was accomplished with a John Deere 410G rubber tire-mounted backhoe equipped with a 24-inch-wide bucket. The bulk and bag samples collected from the test pits were returned to our laboratory for further examination and testing.

The Exploratory Test Pit Logs describe the vertical sequence of soils and materials encountered in each test pit, based primarily on our field classifications and supported by our subsequent laboratory examination and testing. Where a soil contact was observed to be gradual, our logs indicate the average contact depth. Our logs also graphically indicate the sample type, sample number, and approximate depth of each soil sample obtained from the test pits.

The soils encountered were logged during excavation and provide the basis for the "Logs of Test Pits", Figures A-3 through A-11, this Appendix. These logs show a graphic representation of the soil profile, the location, and depths at which samples were collected.

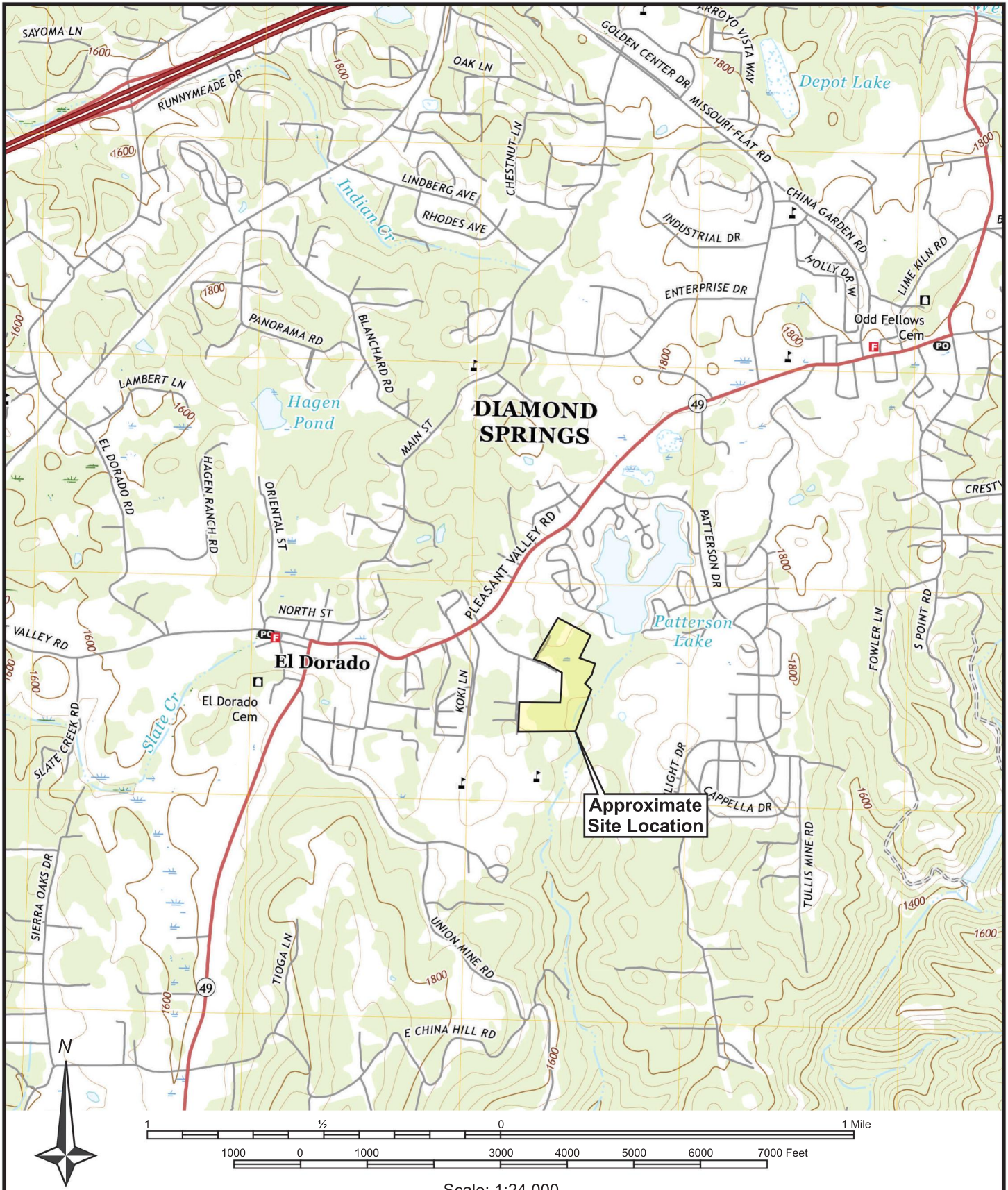

BASE MAP REFERENCE: U.S.G.S. 7.5 Minute Topographic Series, Placerville Quadrangle, Dated 2021



Project No.: E23142.000

July 2023

VICINITY MAP
Diamond Springs Community Park
 Diamond Springs, California

FIGURE
A-1

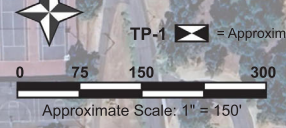

TP-1 [arrow symbol] = Approximate Test Pit Locations

REFERENCE: Google Earth, Aerial Data Dated 5/25/2023

YOUNGDAHL
CONSULTING GROUP, INC.
ESTABLISHED 1984

Project No.:
E23142.000
July 2023

SITE PLAN
Diamond Springs Community Park
Diamond Springs, California

FIGURE
A-2
23-2024 G 33 of 52

| Logged By: ARD | | Date: 27 June 2023 | Lat / Lon: N 38.679568° / W 120.833268° | | Pit No. TP-1 |
|---|---|--|--|--------------|------------------------|
| Equipment: John Deere 410G with 24" Bucket | | | Pit Orientation: 215° | Elevation: ~ | |
| Depth (Feet) | Geotechnical Description & Unified Soil Classification | Sample | Tests & Comments | | |
| @ 0' - 1' | Red yellow silty SAND (SM) , medium dense, dry |  TP-1 @ 1' | | | |
| @ 1' - 4' | Light brown BEDROCK , highly weathered, hard | | | | |
| @ 4' | <i>Grades moderately weathered</i> | | | | |
| | Test pit terminated at 4' (practical refusal) No free groundwater encountered No caving noted | | | | |

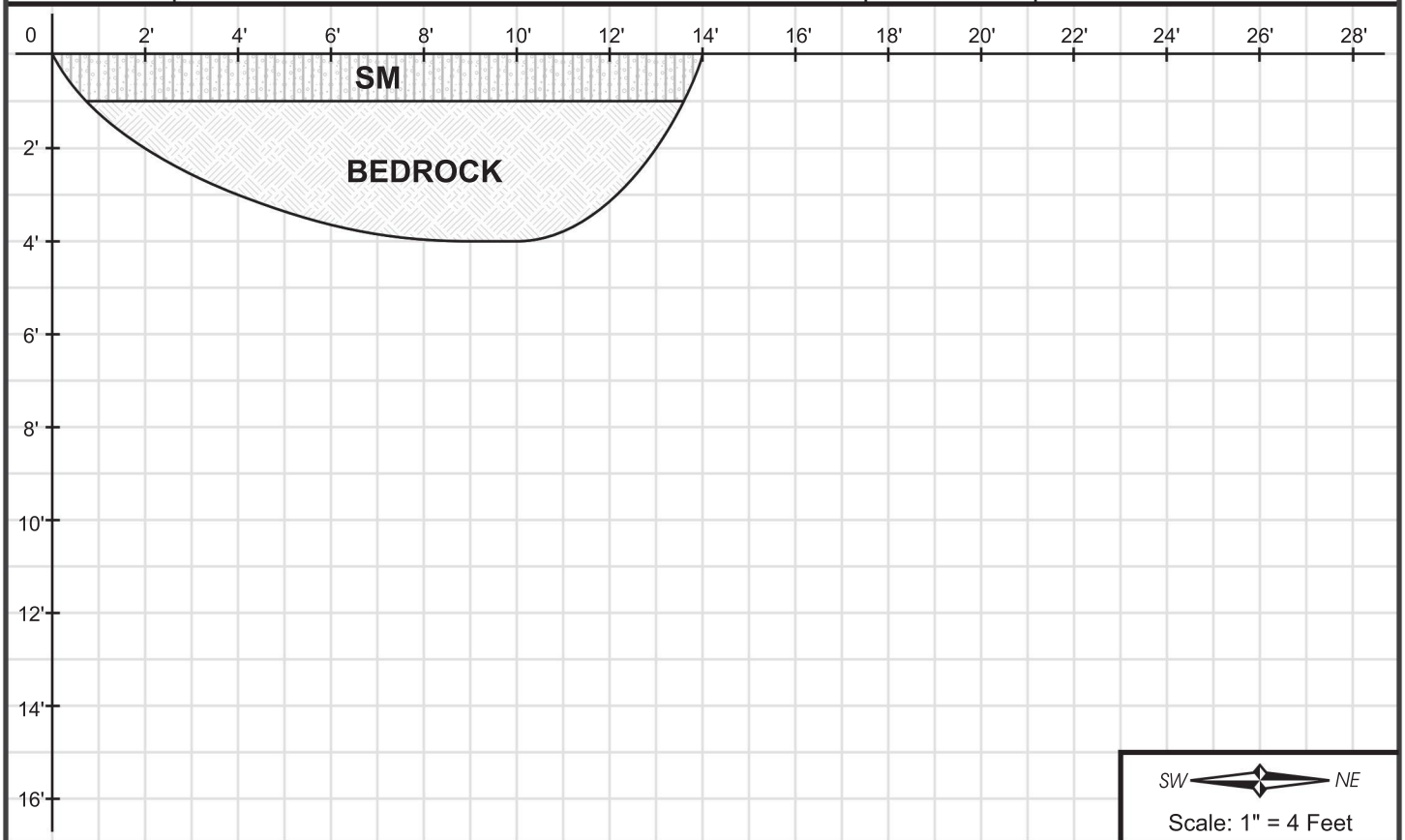

SW  NE
Scale: 1" = 4 Feet

Note: The test pit log indicates subsurface conditions only at the specific location and time noted. Subsurface conditions, including groundwater levels, at other locations of the subject site may differ significantly from conditions which, in the opinion of Youngdahl Consulting Group, Inc., exist at the sampling locations, Note, too, that the passage of time may affect conditions at the sampling locations.

| | | | |
|---|----------------------------|--|-----------------------------|
|  YOUNGDAHL CONSULTING GROUP, INC. <small>ESTABLISHED 1984</small> | Project No.: E23142.000 | EXPLORATORY TEST PIT LOG Diamond Springs Community Park Diamond Springs, California | FIGURE A-3 |
| | July 2023 | | |

| Logged By: ARD | | Date: 27 June 2023 | Lat / Lon: N 38.679330° / W 120.834302° | Pit No. TP-2 |
|---|---|--|--|------------------------|
| Equipment: John Deere 410G with 24" Bucket | | Pit Orientation: 85° | Elevation: ~ | |
| Depth (Feet) | Geotechnical Description & Unified Soil Classification | Sample | Tests & Comments | |
| @ 0' - 2' | Brown silty SAND (SM) , medium dense, dry |  TP-2 @ 3' | | |
| @ 2' - 4.5' | Dark brown BEDROCK , highly weathered, hard | | | |
| @ 4.5' | <i>Grades moderately weathered</i> | | | |
| | Test pit terminated at 4.5' (practical refusal) No free groundwater encountered No caving noted | | | |

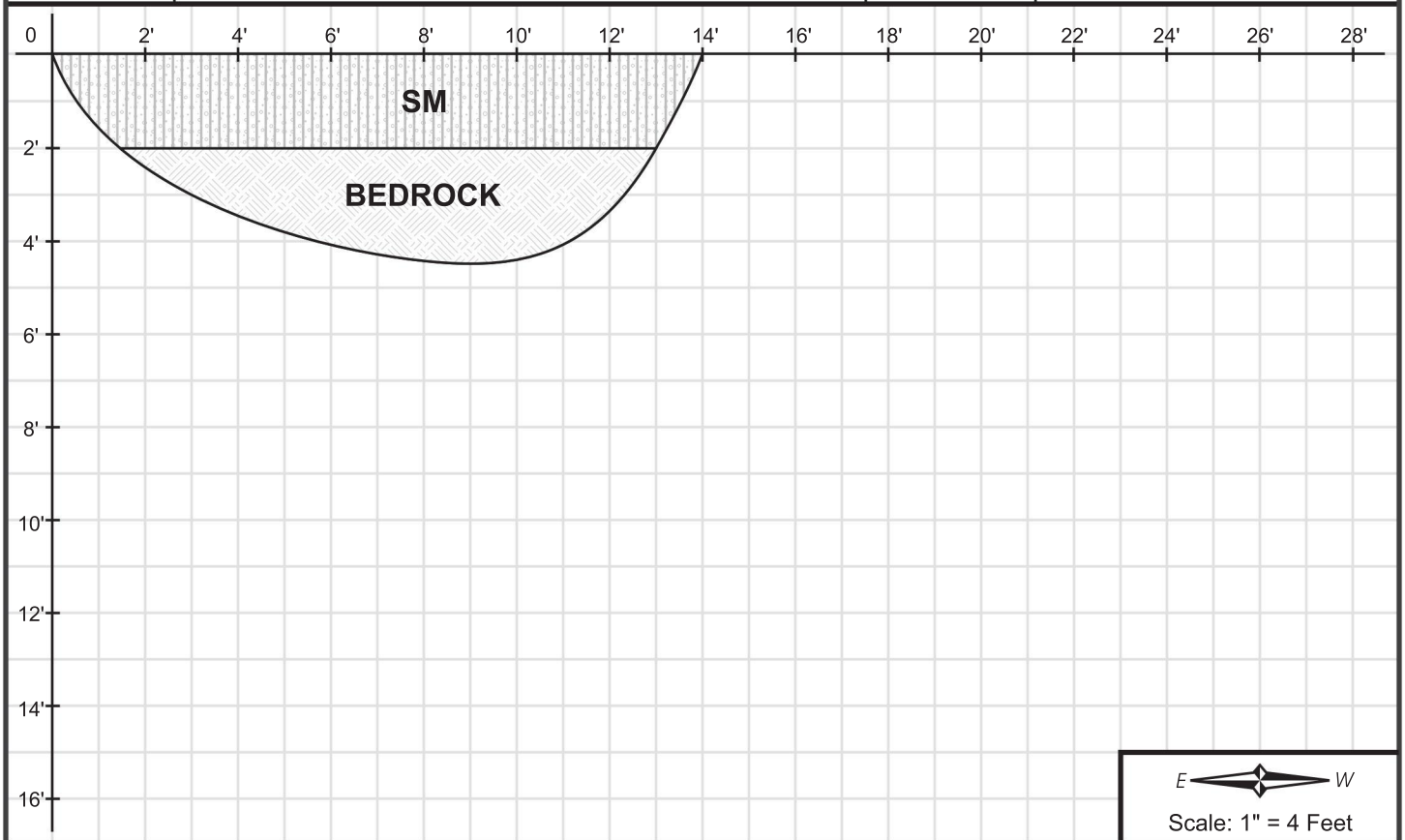

Note: The test pit log indicates subsurface conditions only at the specific location and time noted. Subsurface conditions, including groundwater levels, at other locations of the subject site may differ significantly from conditions which, in the opinion of Youngdahl Consulting Group, Inc., exist at the sampling locations, Note, too, that the passage of time may affect conditions at the sampling locations.

| | | | |
|---|----------------------------|--|-----------------------------|
|  YOUNGDAHL CONSULTING GROUP, INC. <small>ESTABLISHED 1984</small> | Project No.: E23142.000 | EXPLORATORY TEST PIT LOG Diamond Springs Community Park Diamond Springs, California | FIGURE A-4 |
| | July 2023 | | |

| Logged By: ARD | | Date: 27 June 2023 | Lat / Lon: N 38.678725° / W 120.833967° | | Pit No. TP-3 |
|---|---|---------------------------|--|--------------|------------------------|
| Equipment: John Deere 410G with 24" Bucket | | | Pit Orientation: 250° | Elevation: ~ | |
| Depth (Feet) | Geotechnical Description & Unified Soil Classification | Sample | Tests & Comments | | |
| @ 0' - 0.5' | Light brown silty SAND (SM) , medium dense, dry | | | | |
| @ 0.5' - 4' | Red brown to blue grey BEDROCK , highly weathered, moderately hard to hard | | | | |
| @ 4' - 5.5' | <i>Grades dark red brown to blue grey, hard</i> | | | | |
| @ 5.5' | <i>Grades moderately weathered</i> | | | | |
| | Test pit terminated at 5.5' (practical refusal) No free groundwater encountered No caving noted | | | | |

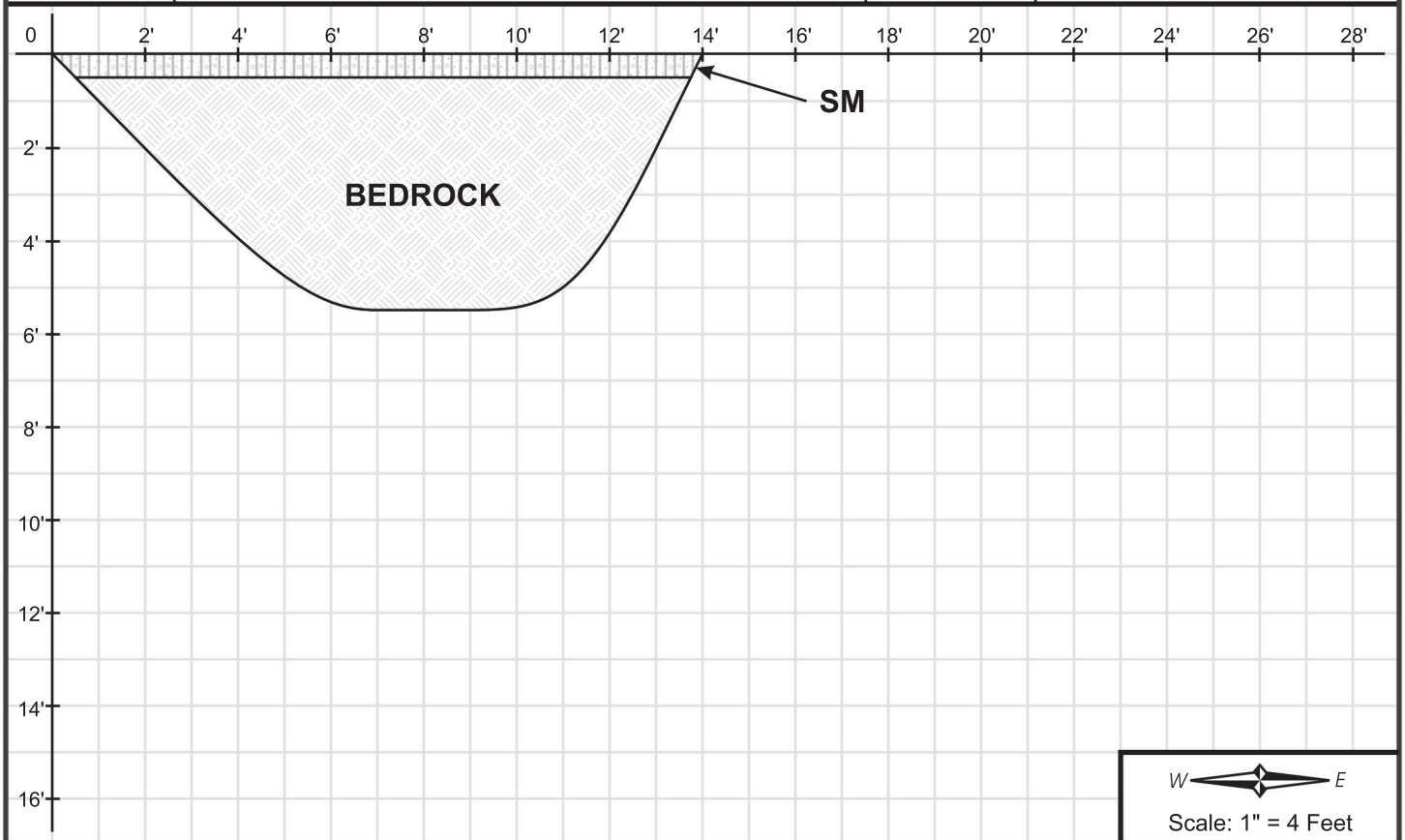

Note: The test pit log indicates subsurface conditions only at the specific location and time noted. Subsurface conditions, including groundwater levels, at other locations of the subject site may differ significantly from conditions which, in the opinion of Youngdahl Consulting Group, Inc., exist at the sampling locations, Note, too, that the passage of time may affect conditions at the sampling locations.

| | | | |
|---|----------------------------|--|-----------------------------|
|  YOUNGDAHL CONSULTING GROUP, INC. <small>ESTABLISHED 1984</small> | Project No.: E23142.000 | EXPLORATORY TEST PIT LOG Diamond Springs Community Park Diamond Springs, California | FIGURE A-5 |
| | July 2023 | | |

| Logged By: ARD | | Date: 27 June 2023 | Lat / Lon: N 38.678621° / W 120.835565° | | Pit No. TP-4 |
|---|---|--|--|--------------|------------------------|
| Equipment: John Deere 410G with 24" Bucket | | | Pit Orientation: 64° | Elevation: ~ | |
| Depth (Feet) | Geotechnical Description & Unified Soil Classification | Sample | Tests & Comments | | |
| @ 0' - 2' | Brown silty SAND (SM) with gravel, medium dense, dry |  TP-4 @ 4' | | | |
| @ 2' - 5' | White BEDROCK , highly weathered, moderately soft to moderately hard | | | | |
| @ 5' | <i>Grades moderately weathered, hard</i> | | | | |
| | Test pit terminated at 5' (practical refusal) No free groundwater encountered No caving noted | | | | |

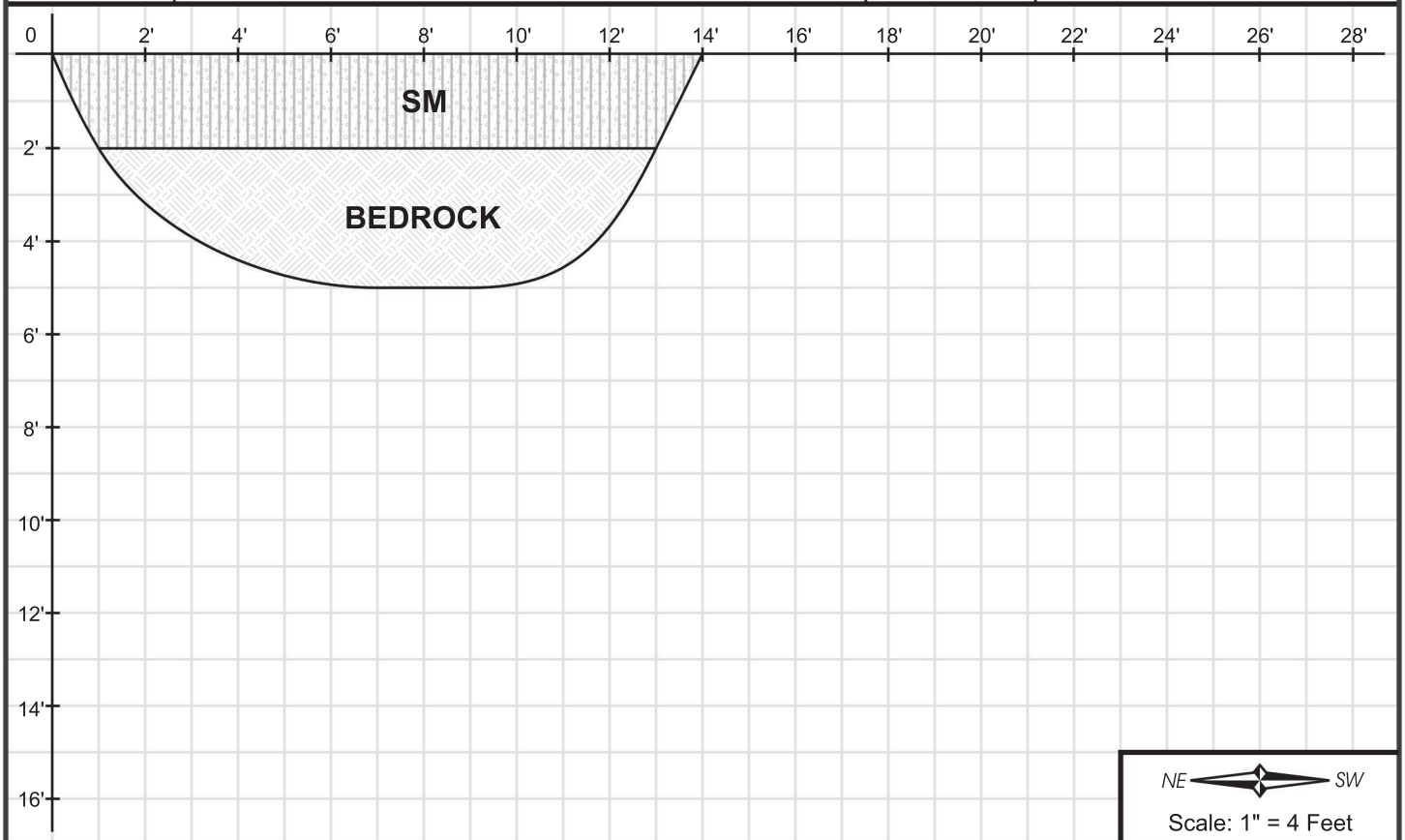

Note: The test pit log indicates subsurface conditions only at the specific location and time noted. Subsurface conditions, including groundwater levels, at other locations of the subject site may differ significantly from conditions which, in the opinion of Youngdahl Consulting Group, Inc., exist at the sampling locations, Note, too, that the passage of time may affect conditions at the sampling locations.

| | | | |
|---|----------------------------|---|-----------------------------|
|  YOUNGDAHL CONSULTING GROUP, INC. <small>ESTABLISHED 1984</small> | Project No.: E23142.000 | EXPLORATORY TEST PIT LOG Diamond Springs Community Park Diamond Springs, California | FIGURE A-6 |
| | July 2023 | | |

| | | | |
|------------------------|---|--|----------------------------|
| Pit No. TP-5 | Logged By: ARD | | Date: 27 June 2023 |
| | Equipment: John Deere 410G with 24" Bucket | | Pit Orientation: 5° |
| Elevation: ~ | | Lat / Lon: N 38.680150° / W 120.833704° | |

| Depth (Feet) | Geotechnical Description & Unified Soil Classification | Sample | Tests & Comments |
|--------------|---|--------|------------------|
| @ 0' - 2' | Light brown silty SAND (SM) , medium dense, dry | | |
| @ 2' - 4' | Yellow brown BEDROCK , completely weathered, very soft to soft | | |
| @ 4' - 7' | Grades white to tan, highly weathered | | |
| @ 7' | Grades moderately weathered, moderately hard | | |
| | Test pit terminated at 7' (practical refusal) No free groundwater encountered No caving noted | | |

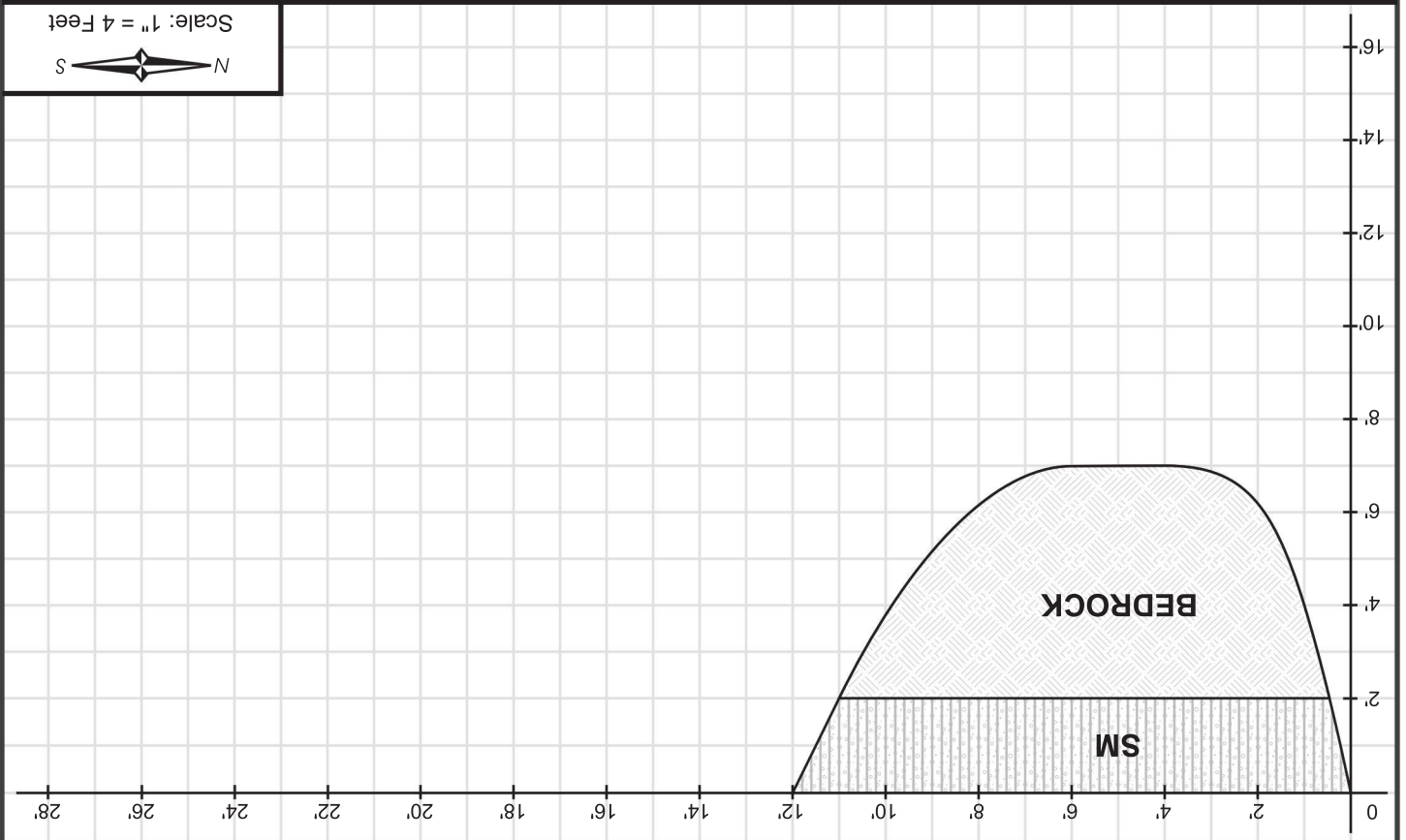

Note: The test pit log indicates subsurface conditions only at the specific location and time noted. Subsurface conditions, including groundwater levels, at other locations of the subject site may differ significantly from conditions which, in the opinion of Youngdahl Consulting Group, Inc., exist at the sampling locations. Note, too, that the passage of time may affect conditions at the sampling locations.



Project No.:
E23142.000

July 2023

EXPLORATORY TEST PIT LOG
Diamond Springs Community Park
Diamond Springs, California

FIGURE
A-7

| Logged By: ARD | | Date: 27 June 2023 | Lat / Lon: N 38.681374° / W 120.834216° | | Pit No. |
|---|--|--|--|--|-------------|
| Equipment: John Deere 410G with 24" Bucket | | Pit Orientation: 19° | Elevation: ~ | | TP-6 |
| Depth (Feet) | Geotechnical Description & Unified Soil Classification | Sample | Tests & Comments | | |
| @ 0' - 3' | Olive brown SILT (ML) with sand and gravel, soft to medium stiff, dry |  TP-6 @ 1' | | | |
| @ 3' - 6' | White to tan BEDROCK , highly weathered, moderately soft | | | | |
| @ 6' | <i>Grades moderately weathered, moderately hard</i> | | | | |
| Test pit terminated at 6' (practical refusal) No free groundwater encountered No caving noted | | | | | |

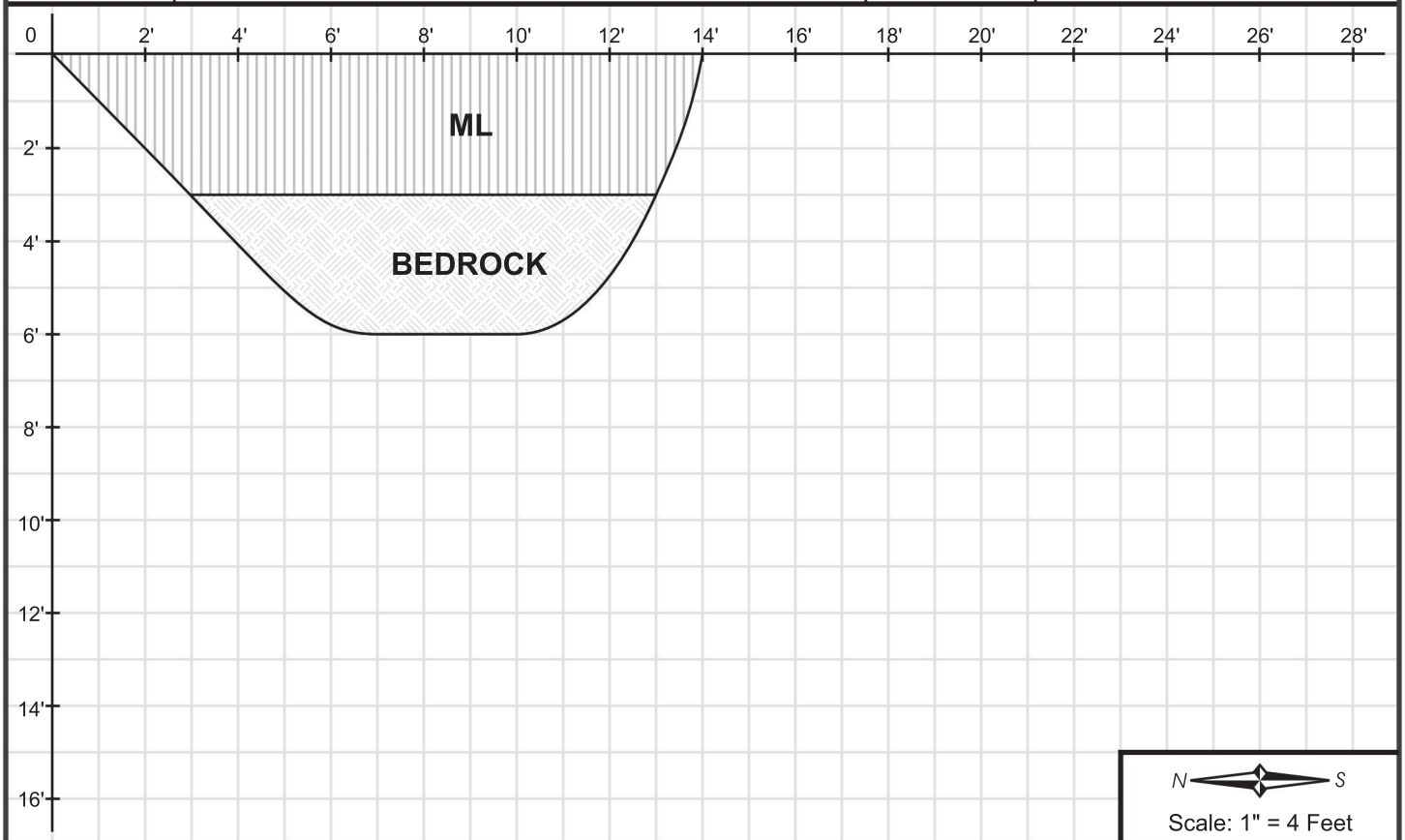

Note: The test pit log indicates subsurface conditions only at the specific location and time noted. Subsurface conditions, including groundwater levels, at other locations of the subject site may differ significantly from conditions which, in the opinion of Youngdahl Consulting Group, Inc., exist at the sampling locations, Note, too, that the passage of time may affect conditions at the sampling locations.

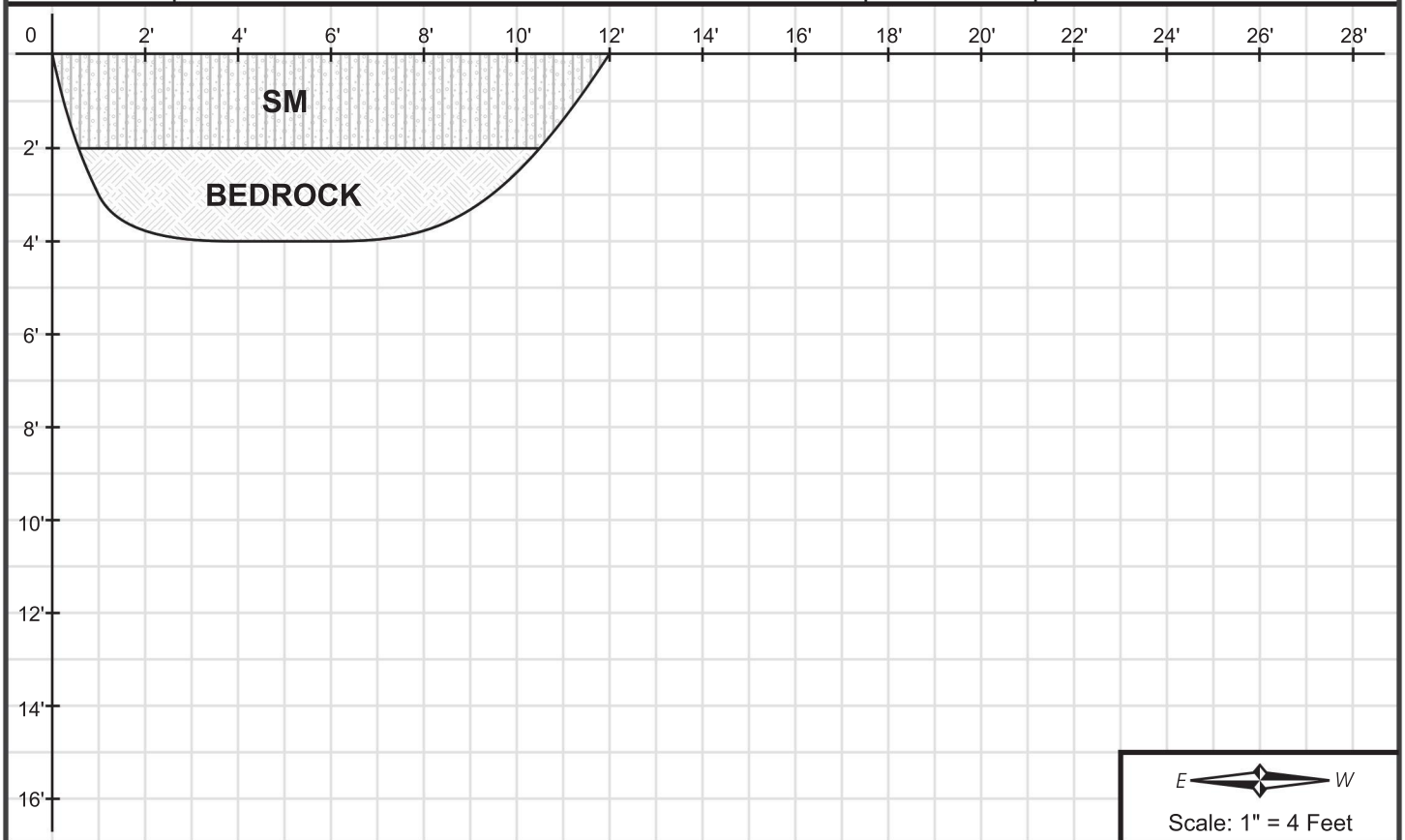

| | | | |
|---|----------------------------|--|-----------------------------|
|  YOUNGDAHL CONSULTING GROUP, INC. <small>ESTABLISHED 1984</small> | Project No.: E23142.000 | EXPLORATORY TEST PIT LOG Diamond Springs Community Park Diamond Springs, California | FIGURE A-8 |
| | July 2023 | | |

| Logged By: ARD | | Date: 27 June 2023 | Lat / Lon: N 38.681908° / W 120.833059° | | Pit No. TP-7 |
|---|---|--|--|--------------|------------------------|
| Equipment: John Deere 410G with 24" Bucket | | | Pit Orientation: 110° | Elevation: ~ | |
| Depth (Feet) | Geotechnical Description & Unified Soil Classification | Sample | Tests & Comments | | |
| @ 0' - 2' | Light brown silty SAND (SM) , medium dense, dry to slightly moist |  TP-7 @ 3' | | | |
| @ 2' - 4' | White to tan BEDROCK , highly weathered, soft to moderately soft | | | | |
| @ 4' | <i>Grades moderately weathered, moderately hard</i> | | | | |
| | Test pit terminated at 6' (practical refusal) No free groundwater encountered No caving noted | | | | |



Note: The test pit log indicates subsurface conditions only at the specific location and time noted. Subsurface conditions, including groundwater levels, at other locations of the subject site may differ significantly from conditions which, in the opinion of Youngdahl Consulting Group, Inc., exist at the sampling locations, Note, too, that the passage of time may affect conditions at the sampling locations.

| | | | |
|---|----------------------------|---|-----------------------------|
|  YOUNGDAHL CONSULTING GROUP, INC. <small>ESTABLISHED 1984</small> | Project No.: E23142.000 | EXPLORATORY TEST PIT LOG Diamond Springs Community Park Diamond Springs, California | FIGURE A-9 |
| | July 2023 | | |

| Logged By: ARD | | Date: 27 June 2023 | Lat / Lon: N 38.681169° / W 120.833299° | Pit No. TP-8 |
|---|---|--|--|------------------------|
| Equipment: John Deere 410G with 24" Bucket | | Pit Orientation: 265° | Elevation: ~ | |
| Depth (Feet) | Geotechnical Description & Unified Soil Classification | Sample | Tests & Comments | |
| @ 0' - 1.5' | Brown CLAY (CL) , low plasticity, soft to medium stiff, slightly moist |  TP-8 @ 1' | | |
| @ 1.5' - 3' | <i>Grades pale olive brown, medium stiff</i> |  TP-8 @ 2' | | |
| @ 3' - 6' | Brown to grey BEDROCK , completely weathered, very soft to soft | | | |
| @ 6' - 8' | <i>Grades red yellow, highly weathered, moderately hard</i> | | | |
| @ 8' | <i>Grades moderately weathered, moderately hard</i> | | | |
| | Test pit terminated at 8' (practical refusal) No free groundwater encountered No caving noted | | | |

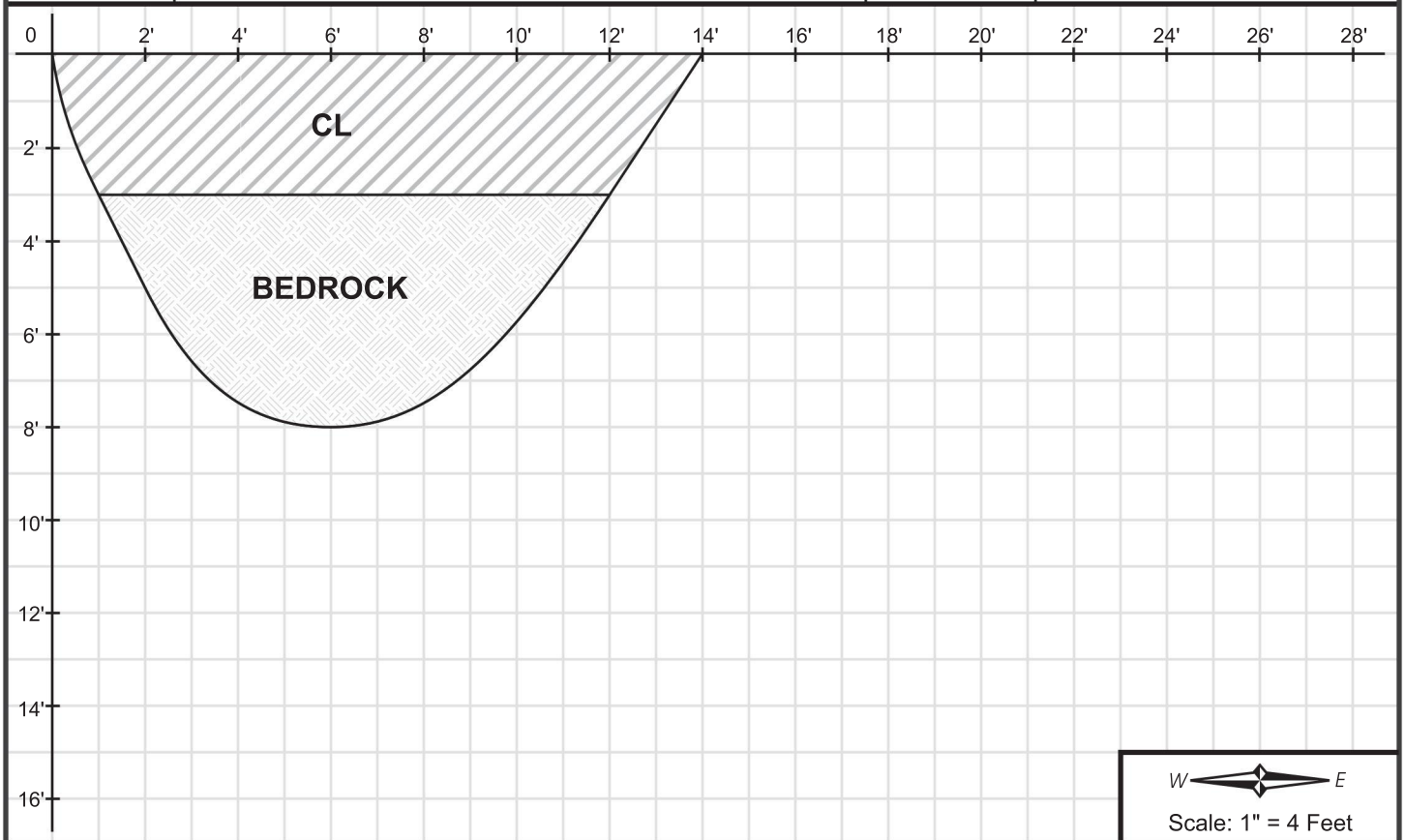

Note: The test pit log indicates subsurface conditions only at the specific location and time noted. Subsurface conditions, including groundwater levels, at other locations of the subject site may differ significantly from conditions which, in the opinion of Youngdahl Consulting Group, Inc., exist at the sampling locations, Note, too, that the passage of time may affect conditions at the sampling locations.

| | | | |
|---|----------------------------|---|------------------------------|
|  YOUNGDAHL CONSULTING GROUP, INC. <small>ESTABLISHED 1984</small> | Project No.: E23142.000 | EXPLORATORY TEST PIT LOG Diamond Springs Community Park Diamond Springs, California | FIGURE A-10 |
| | July 2023 | | |

| | | | | |
|---------------------|--|--|------------------------------|---|
| Pit No. TP-9 | Logged By: ARD | | Date: 27 June 2023 | Equipment: John Deere 410G with 24" Bucket |
| | Lat / Lon: N 38.680916° / W 120.832879° | | Pit Orientation: 272° | Elevation: ~ |

| Depth (Feet) | Geotechnical Description & Unified Soil Classification | Sample | Tests & Comments |
|--------------|---|--------|------------------|
| @ 0' - 1' | Brown silty SAND (SM) with clay, medium dense, dry to slightly moist | | |
| @ 1' - 4' | White to tan BEDROCK , completely weathered, very soft to soft | | |
| @ 4' - 6' | Grades light brown, highly weathered, moderately hard | | |
| @ 6' | Grades moderately weathered, moderately hard | | |
| | Test pit terminated at 6' (practical refusal) No free groundwater encountered No caving noted | | |

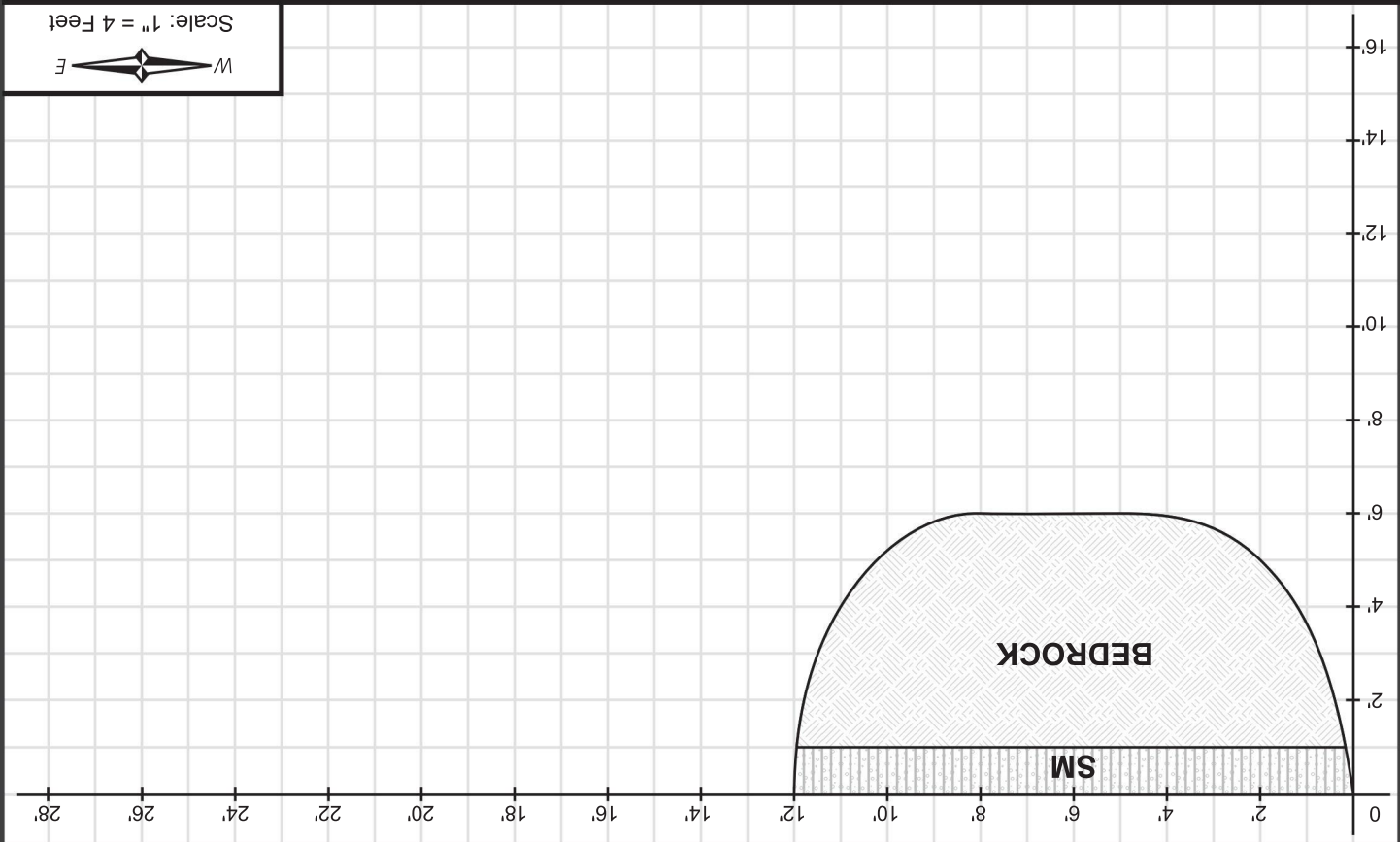

Note: The test pit log indicates subsurface conditions only at the specific location and time noted. Subsurface conditions, including groundwater levels, at other locations of the subject site may differ significantly from conditions which, in the opinion of Youngdahl Consulting Group, Inc., exist at the sampling locations. Note, too, that the passage of time may affect conditions at the sampling locations.



Project No.: E23142.000
July 2023

EXPLORATORY TEST PIT LOG
Diamond Springs Community Park
Diamond Springs, California

FIGURE **A-11**

UNIFIED SOIL CLASSIFICATION SYSTEMS

| MAJOR DIVISION | | SYMBOLS | TYPICAL NAMES |
|---|--------------------------------------|---|--|
| COARSE GRAINED SOILS Over 50% > #200 sieve | GRAVELS Over 50% > #4 sieve | Clean GRAVELS With Little Or No Fines | GW Well graded GRAVELS, GRAVEL-SAND mixtures |
| | | | GP Poorly graded GRAVELS, GRAVEL-SAND mixtures |
| | | GRAVELS With Over 12% Fines | GM Silty GRAVELS, poorly graded GRAVEL-SAND-SILT mixtures |
| | | | GC Clayey GRAVELS, poorly graded GRAVEL-SAND-CLAY mixtures |
| | SANDS Over 50% < #4 sieve | Clean SANDS With Little Or No Fines | SW Well graded SANDS, gravelly SANDS |
| | | | SP Poorly graded SANDS, gravelly SANDS |
| | | SANDS With Over 12% Fines | SM Silty SANDS, poorly graded SAND-SILT mixtures |
| | | | SC Clayey SANDS, poorly graded SAND-CLAY mixtures |
| FINE GRAINED SOILS Over 50% < #200 sieve | SILTS & CLAYS Liquid Limit < 50 | ML Inorganic SILTS, silty or clayey fine SANDS, or clayey SILTS with plasticity | |
| | | CL Inorganic CLAYS of low to medium plasticity, gravelly, sandy, or silty CLAYS, lean CLAYS | |
| | | OL Organic CLAYS and organic silty CLAYS of low plasticity | |
| | SILTS & CLAYS Liquid Limit > 50 | MH Inorganic SILTS, micaceous or diamaceous fine sandy or silty soils, elastic SILTS | |
| | | CH Inorganic CLAYS of high plasticity, fat CLAYS | |
| | | OH Organic CLAYS of medium to high plasticity, organic SILTS | |
| HIGHLY ORGANIC CLAYS | PT PEAT & other highly organic soils | | |

PLASTICITY CHART

USED FOR CLASSIFICATION OF FINE GRAINED SOILS

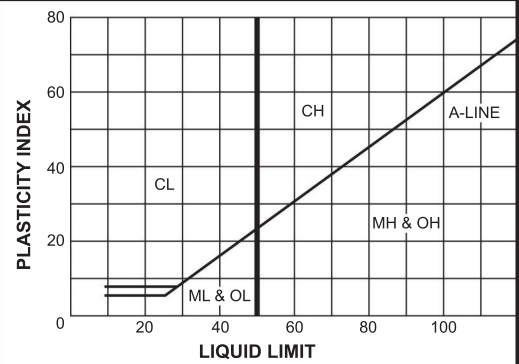

SAMPLE DRIVING RECORD

| BLOWS PER FOOT | DESCRIPTION |
|----------------|---|
| 25 | 25 Blows drove sampler 12 inches, after initial 6 inches of seating |
| 50/7" | 50 Blows drove sampler 7 inches, after initial 6 inches of seating |
| 50/3" | 50 Blows drove sampler 3 inches during or after initial 6 inches of seating |

Note: To avoid damage to sampling tools, driving is limited to 50 blows per 6 inches during or after seating interval.

SOIL GRAIN SIZE

| U.S. STANDARD SIEVE | 6" | 3" | ¾" | 4 | 10 | 40 | 200 | | |
|--------------------------------|---------|--------|--------|------|--------|--------|-------|-------|------|
| | BOULDER | COBBLE | GRAVEL | | SAND | | | SILT | CLAY |
| | | | COARSE | FINE | COARSE | MEDIUM | FINE | | |
| SOIL GRAIN SIZE IN MILLIMETERS | 150 | 75 | 19 | 4.75 | 2.0 | .425 | 0.075 | 0.002 | |

KEY TO PIT & BORING SYMBOLS

- Standard Penetration test
- 2.5" O.D. Modified California Sampler
- 3" O.D. Modified California Sampler
- Shelby Tube Sampler
- 2.5" Hand Driven Liner
- Bulk Sample
- Water Level At Time Of Drilling
- Water Level After Time Of Drilling
- Perched Water

KEY TO PIT & BORING SYMBOLS

- Joint
- Foliation
- Water Seepage
- NFWE No Free Water Encountered
- FWE Free Water Encountered
- REF Sampling Refusal
- DD Dry Density (pcf)
- MC Moisture Content (%)
- LL Liquid Limit
- PI Plasticity Index
- PP Pocket Penetrometer
- UCC Unconfined Compression (ASTM D2166)
- TVS Pocket Torvane Shear
- EI Expansion Index (ASTM D4829)
- Su Undrained Shear Strength

APPENDIX B
Laboratory Testing

Direct Shear Test
Expansion Index Test
Modified Proctor Test
R-Value Test

Direct Shear Test of Soils Under Consolidated Drained Conditions, ASTM D3080

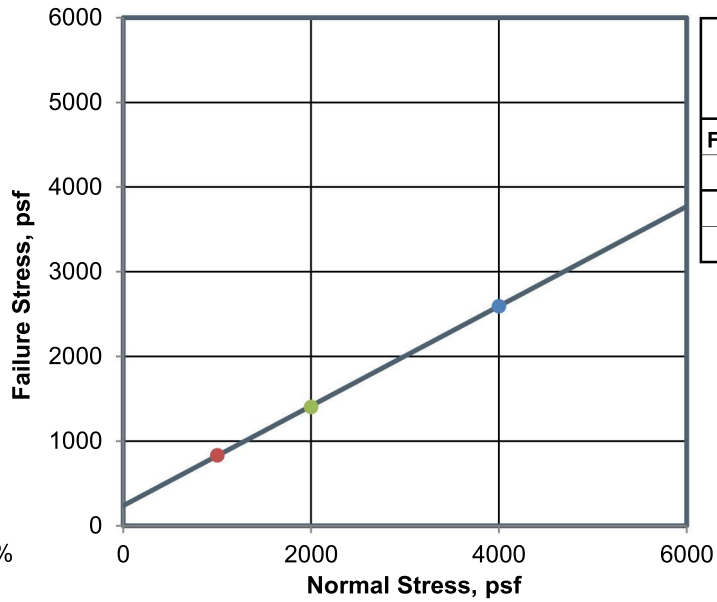
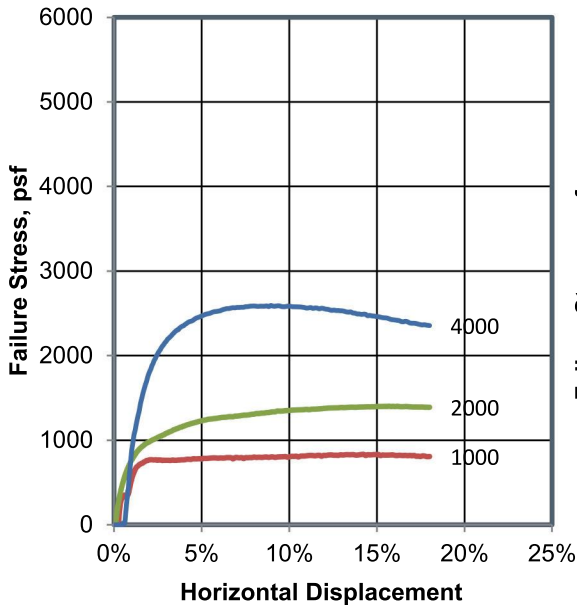

| | |
|--------------------------------|---------|
| Direct Shearbox Results | |
| Friction Angle | 30.5° |
| Cohesion | 237 psf |

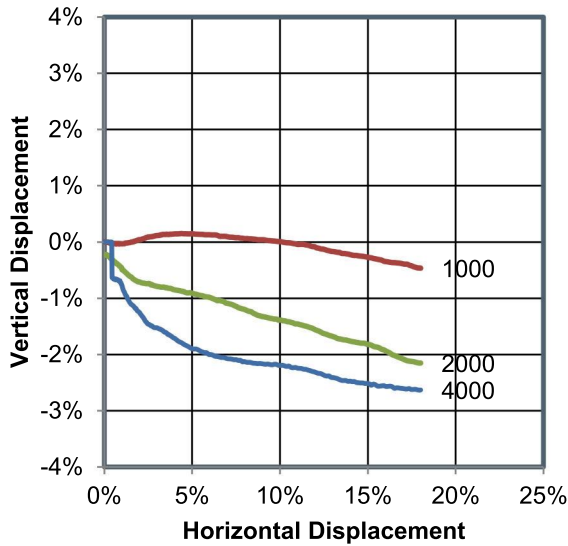

| Test No. | | 1 | 2 | 3 |
|---------------------|----------------------|-------|-------|-------|
| Initial | Wet Density, pcf | 104.6 | 104.6 | 104.6 |
| | Dry Density, pcf | 89.1 | 89.1 | 89.1 |
| | Moisture Content, % | 17.4 | 17.4 | 17.4 |
| | Diameter, in | 2.50 | 2.50 | 2.50 |
| | Height, in | 1.00 | 1.00 | 1.00 |
| Pre Shear | Wet Density, pcf | 124.3 | 126.5 | 128.4 |
| | Dry Density, pcf | 91.2 | 92.3 | 93.5 |
| | Moisture Content, %* | 36.3 | 37.0 | 37.4 |
| | Diameter, in | 2.50 | 2.50 | 2.50 |
| | Height, in | 0.98 | 0.97 | 0.95 |
| Normal Stress, psf | | 1000 | 2000 | 4000 |
| Failure Stress, psf | | 832 | 1401 | 2592 |
| Failure Strain, % | | 14.24 | 15.68 | 8.95 |
| Rate, in/min | | 0.002 | | |

*Based on post shear moisture content

Sample Type: Remolded to 90% RC

Material Description: **Brown Lean CLAY**

Source:

Notes:

| | | | | | |
|-----------------------------|-----------------------------|--------------|------------------|----------------------|---------------------|
| Sample No./Depth: TP-8 @ 1' | USCS Class. | Liquid Limit | Plasticity Index | % Greater than No. 4 | % Less than No. 200 |
| Date Sampled: 6/27/2023 | Date Test Started: 7/5/2023 | | | 0 | |



1234 Glenhaven Court, El Dorado Hills, CA 95762
 ph 916.933.0633 ▪ fx 916.933.6482 ▪ www.youngdahl.net

| | | | |
|--|--|-------------------|----------------------|
| Project: Diamond Springs Community Park GES | | | |
| Project No.: | | E23142.000 | |
| Reviewed By: DN | | Date: 7/7/2023 | Figure B-1 |

Expansion Index of Soils, ASTM D4829

Test Results

| | |
|----------------------------------|------|
| Expansion Index | 74 |
| Dry Density, as molded, pcf | 92.0 |
| Moisture Content, as molded, % | 14.7 |
| Final Moisture Content, % | 34.3 |
| Initial Saturation, as molded, % | 48 |
| Final Degree of Saturation, % | 95 |

Classification of Potentially Expansive Soil

| Expansion Index, EI | Potential Expansion |
|---------------------|---------------------|
| 0 - 20 | Very Low |
| 21 - 50 | Low |
| 51 - 90 | Medium |
| 91 - 130 | High |
| Above 130 | Very High |

Material Description: **Pale Olive Brown Lean Clay**

Source: **Native**

Notes:

| | | | | | |
|---|-------------|--------------|------------------|----------------------|---------------------|
| Sample No./Depth: TP-8 @ 2' | USCS Class. | Liquid Limit | Plasticity Index | % Greater than No. 4 | % Less than No. 200 |
| Date Sampled: 6/27/2023 Date Test Started: 6/29/2023 | | | | 1 | |



YOUNGDAHL

CONSULTING GROUP, INC.

ESTABLISHED 1984

1234 Glenhaven Court, El Dorado Hills, CA 95762
ph 916.933.0633 ▪ fx 916.933.6482 ▪ www.youngdahl.net

Project: **Diamond Springs Community Park
GES**

Project No.: **E23142.000**

Reviewed By: **DN**

Date: **7/7/2023**

Figure

B-2

**Laboratory Compaction Characteristics of Soil
Using Modified Effort (56,000 lbf-ft³), ASTM D1557, Method A**

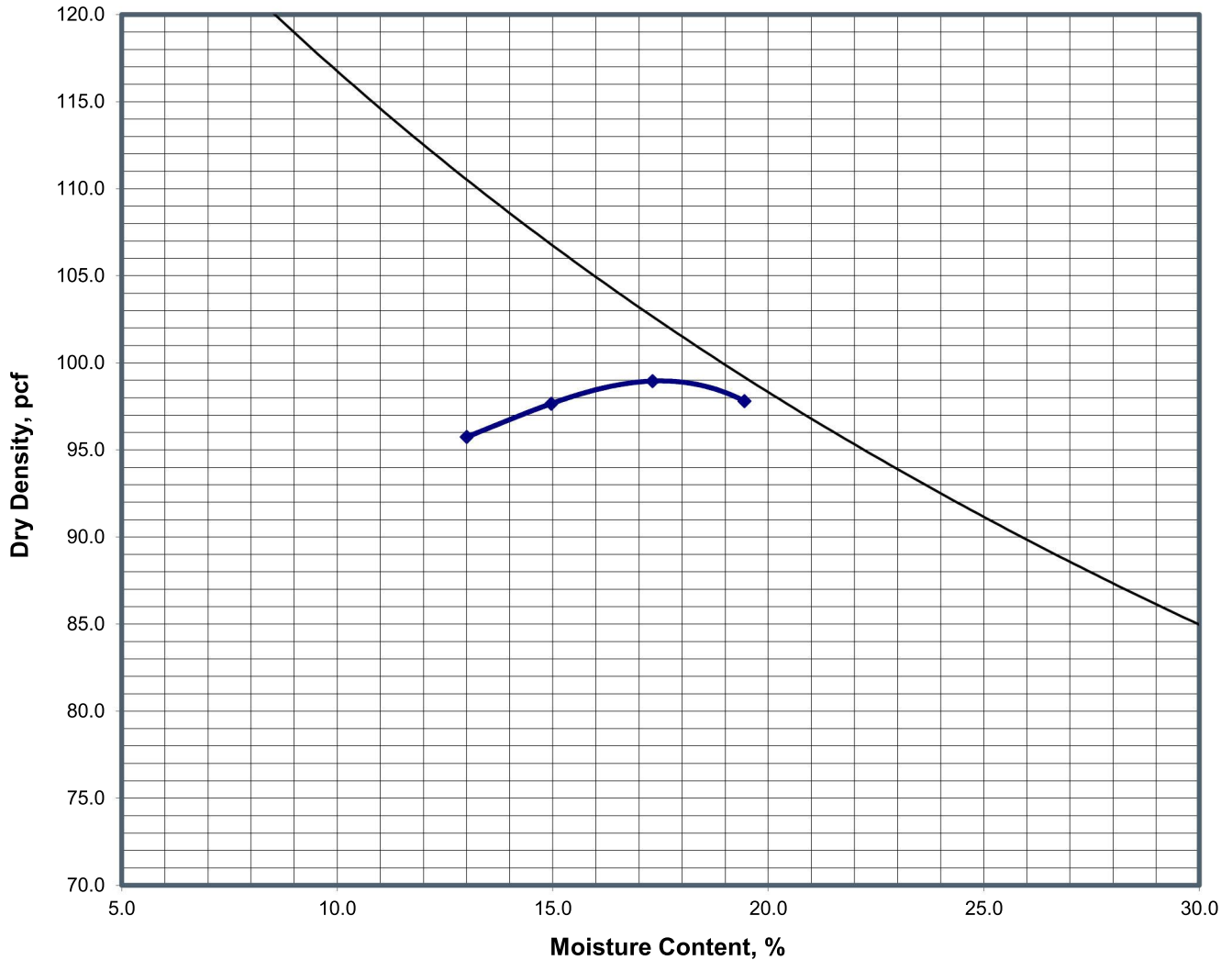

— Zero Air Voids Curve at 100% Saturation;
Specific Gravity Estimated at: 2.30

| | |
|---------------------------------------|--|
| Maximum Dry Density, pcf: 99.0 | Optimum Moisture Content, %: 17.5 |
|---------------------------------------|--|

Material Description: **Brown Lean CLAY**

Source: TP-8 @ 1'

Notes:

| | | | | | |
|----------------------------------|------------------------------|--------------|------------------|------------------------|---------------------|
| Sample No./Depth: Curve 2 | USCS Class. | Liquid Limit | Plasticity Index | % Greater than No. 4 : | % Less than No. 200 |
| Date Sampled: 6/27/2023 | Date Test Started: 6/30/2023 | | | 0 | |



1234 Glenhaven Court, El Dorado Hills, CA 95762
ph 916.933.0633 ▪ fx 916.933.6482 ▪ www.youngdahl.net

Project: **Diamond Springs Community Park
GES**

Project No.: **E23142.000** Figure

Reviewed By: JLC Date: 7/3/2023 **B-3**

Resistance "R" Value of Soil and Soil-Aggregate Mixtures, CTM 301

R- Value Chart

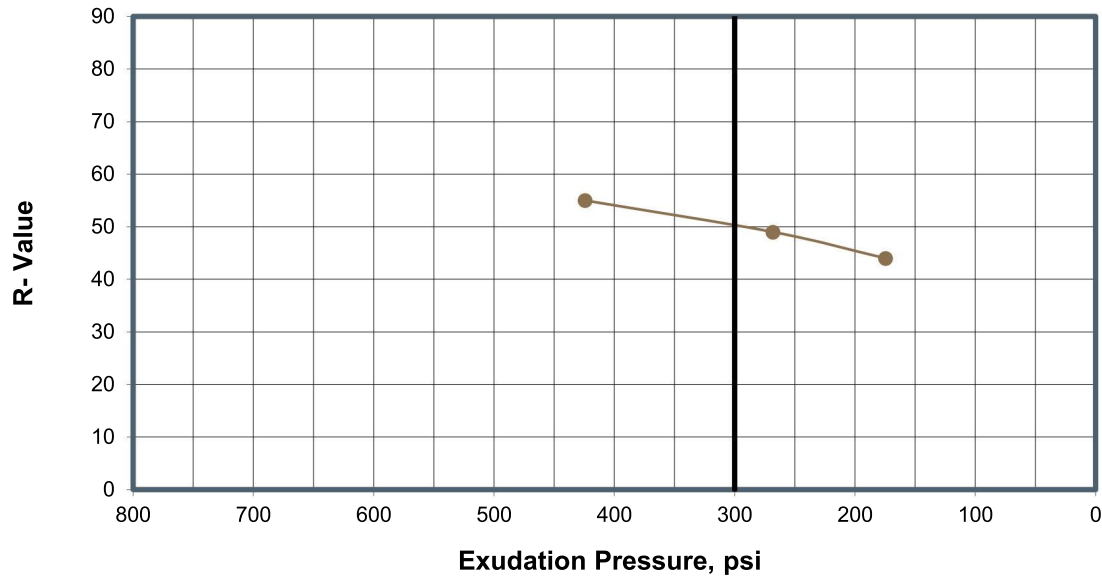

| Test Specimen No.: | 1 | 2 | 3 |
|---|-----------|-------|-------|
| Moisture Content at Test, % | 19.6 | 20.2 | 21.5 |
| Dry Density at Test, pcf | 101.8 | 101.1 | 100.6 |
| Expansion Pressure, psf | 398 | 364 | 333 |
| Exudation Pressure, psi | 424 | 268 | 175 |
| Resistance "R" Value | 55 | 49 | 44 |
| "R" Value at 300 psi Exudation Pressure | 50 | | |

Material Description: **Olive Brown SILT with Sand**

Source:

Notes:

| | | | | | |
|------------------------------------|-------------------------------------|--------------|------------------|----------------------|---------------------|
| Sample No./Depth: TP-6 @ 1' | USCS Class. | Liquid Limit | Plasticity Index | % Greater than No. 4 | % Less than No. 200 |
| Date Sampled: 6/27/2023 | Date Test Started: 6/29/2023 | | | 0 | |

| | | | | |
|--|--|-----------------------|------------|--------|
| | Project: Diamond Springs Community Park GES | | | |
| | Project No.: E23142.000 | | | Figure |
| | Reviewed By: JLC | Date: 7/5/2023 | B-4 | |

APPENDIX C

Details

Geotechnical Details (Large Format)

PLACEMENT OF FILL ON NATURAL SLOPE
(Typical Cross Section)

All keyways should be observed and approved prior to placement of fill.
Any keyway is required by GSC for fill on natural slopes of 2:1 or steeper.

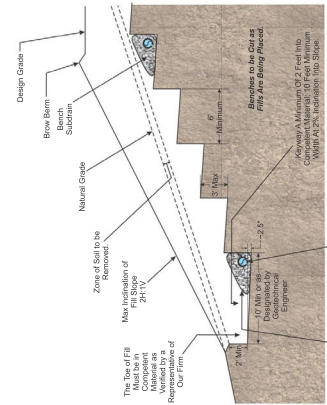

Fill Color: This is Required as Submittal to be Determined at Time of Excavation. Our Firm at Time of Construction.

Retaining Wall With Perforated Pipe Backrain
(Typical Cross Section)

- Notes: 1. Slope trench and "rigid-wall" pipes at least 1% gradient to drain to an appropriate outfall.
- 2. Use "sweeps" for directional flow in pipe flow (do not use 90° elbows).
- 3. Provide periodic "clean-outs".
- 4. Washed clean permeable material.

Not To Scale

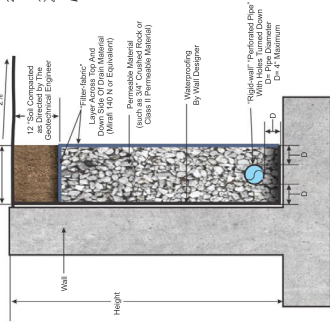

"Two Pipe Slab-on-Grade Subrain" Installation
(Typical Cross Section)

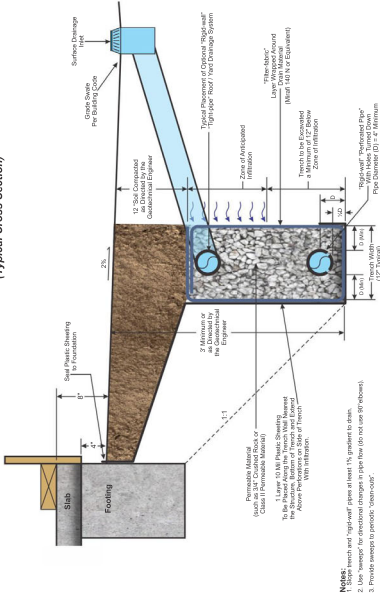

- Notes: 1. Slope trench and "rigid-wall" pipes at least 1% gradient to drain.
- 2. Size "sweeps" for directional changes in pipe flow (do not use 90° elbows).
- 3. Provide periodic "clean-outs".
- 4. Washed clean permeable material.

FOUNDATION PENETRATION PLUG
(Typical Cross Section)

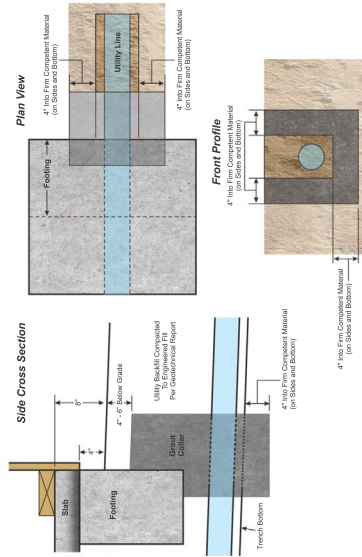

GEOTECHNICAL DETAILS
DIAMOND SPRINGS COMMUNITY PARK
DIAMOND SPRINGS, CA

PROJECT #: E23142.000
SCALE: NOT TO SCALE

DATE: JULY 2023

DESIGNED BY:
DRAWN BY:
CHECKED BY:

APPROVALS

SHEET TITLE
STANDARD
GEOTECHNICAL DETAILS

SHEET TITLE

YCG-1

YOUNGDAHL
CONSULTING GROUP, INC.
1234 Greenway Court, Suite 100
Diamond Springs, CA 95627
P: 916.933.6482
F: 916.933.6482

| REVISIONS | DATE | DESCRIPTION |
|-----------|------|-------------|
| | | |
| | | |
| | | |
| | | |

