

CUP 18-0007 (AT&T Gold Hill/Coloma) EXHIBIT A - VICINITY MAP

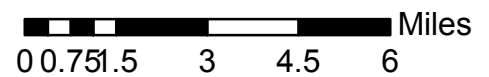

CUP 18-0007 (AT&T Gold Hill/Coloma) EXHIBIT B - LOCATION MAP

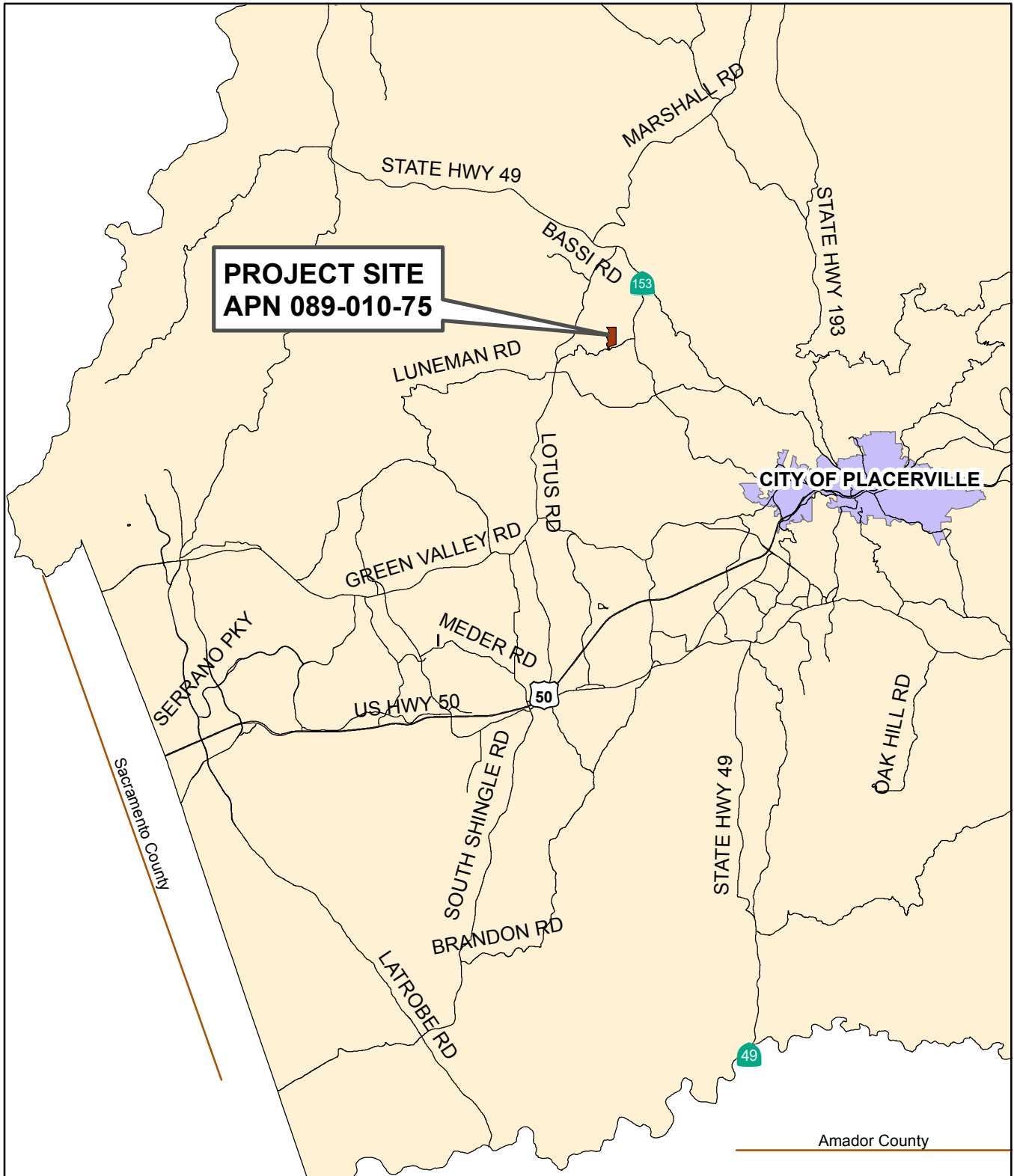
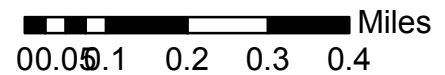
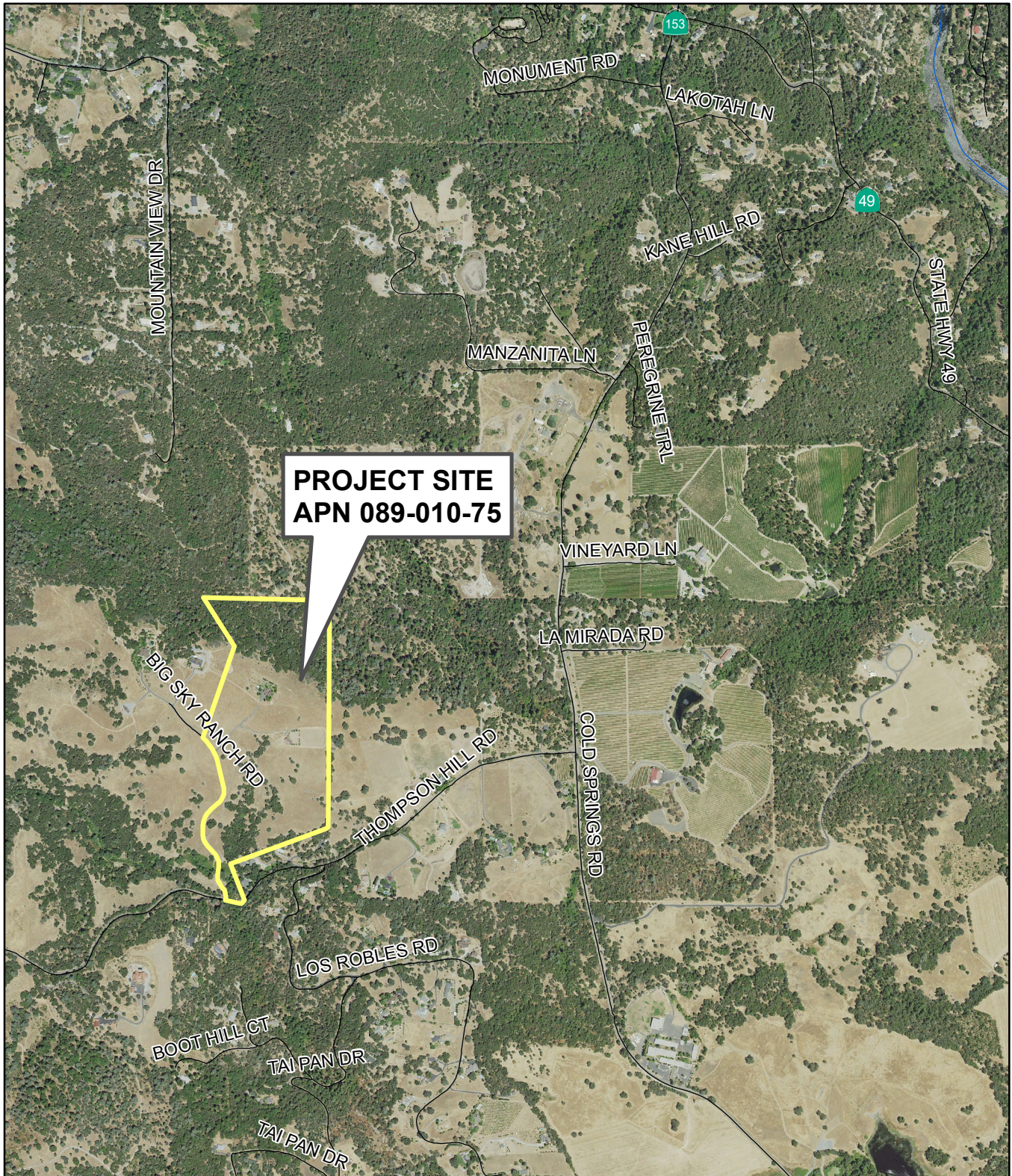

CUP 18-0007 (AT&T Gold Hill/Coloma) EXHIBIT C - Site Aerial Photo

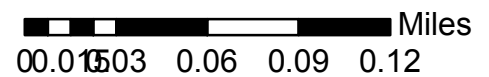
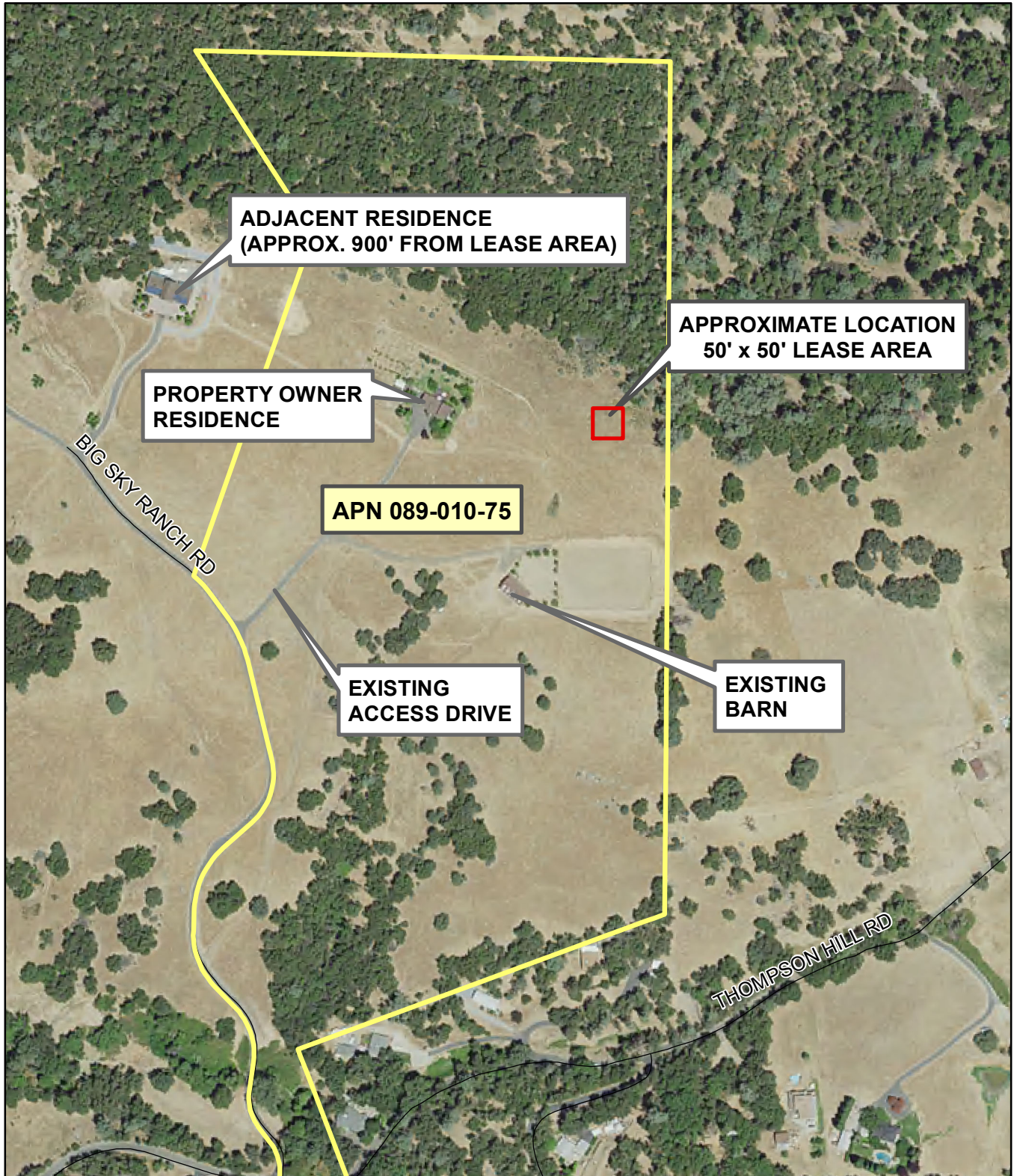

CUP 18-0007 (AT&T Gold Hill/Coloma)
EXHIBIT E - GENERAL PLAN LAND USE MAP

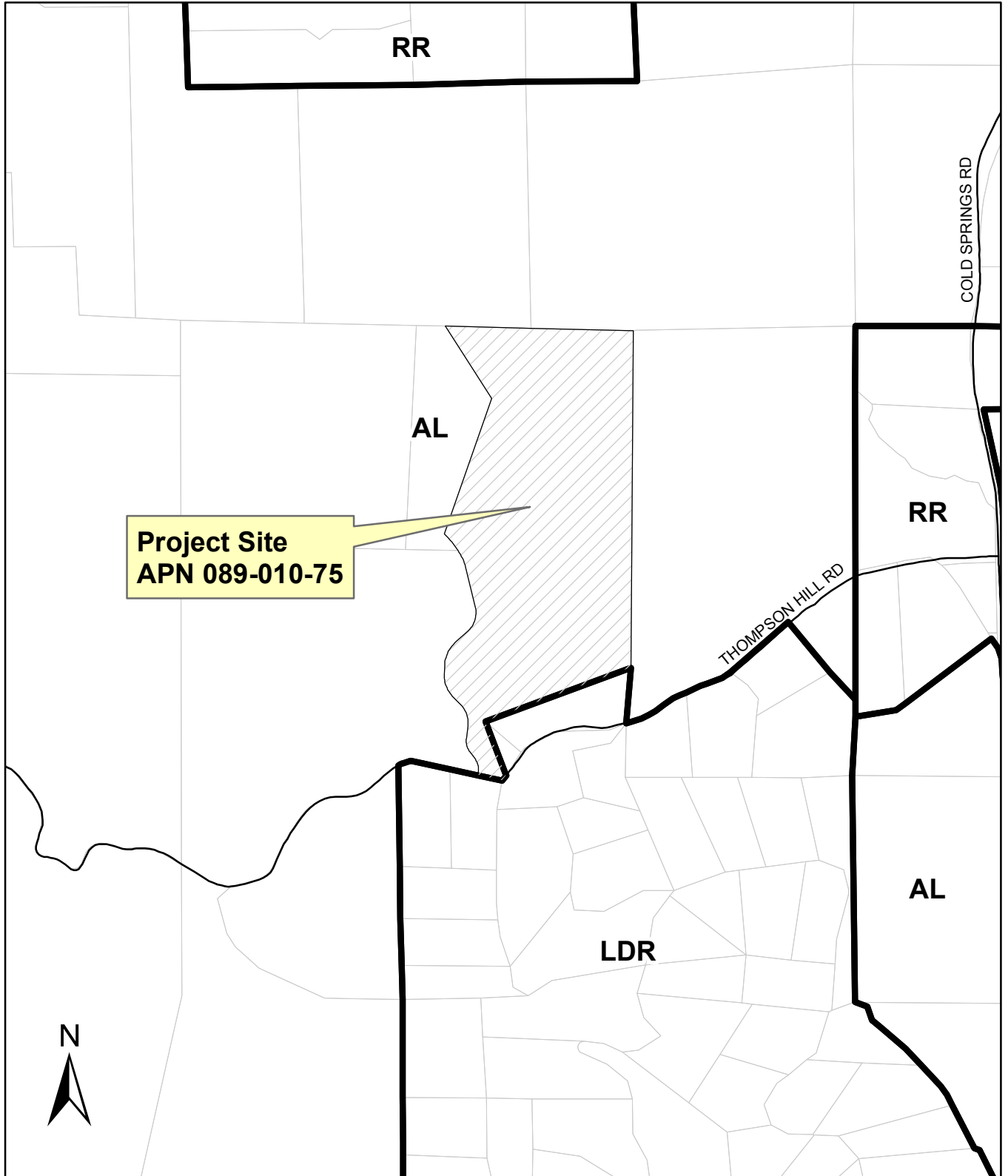

0 0.04 0.09 0.18 0.27 0.36 Miles

CUP 18-0007 (AT&T Gold Hill/Coloma)

EXHIBIT F - ZONING MAP

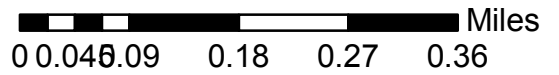
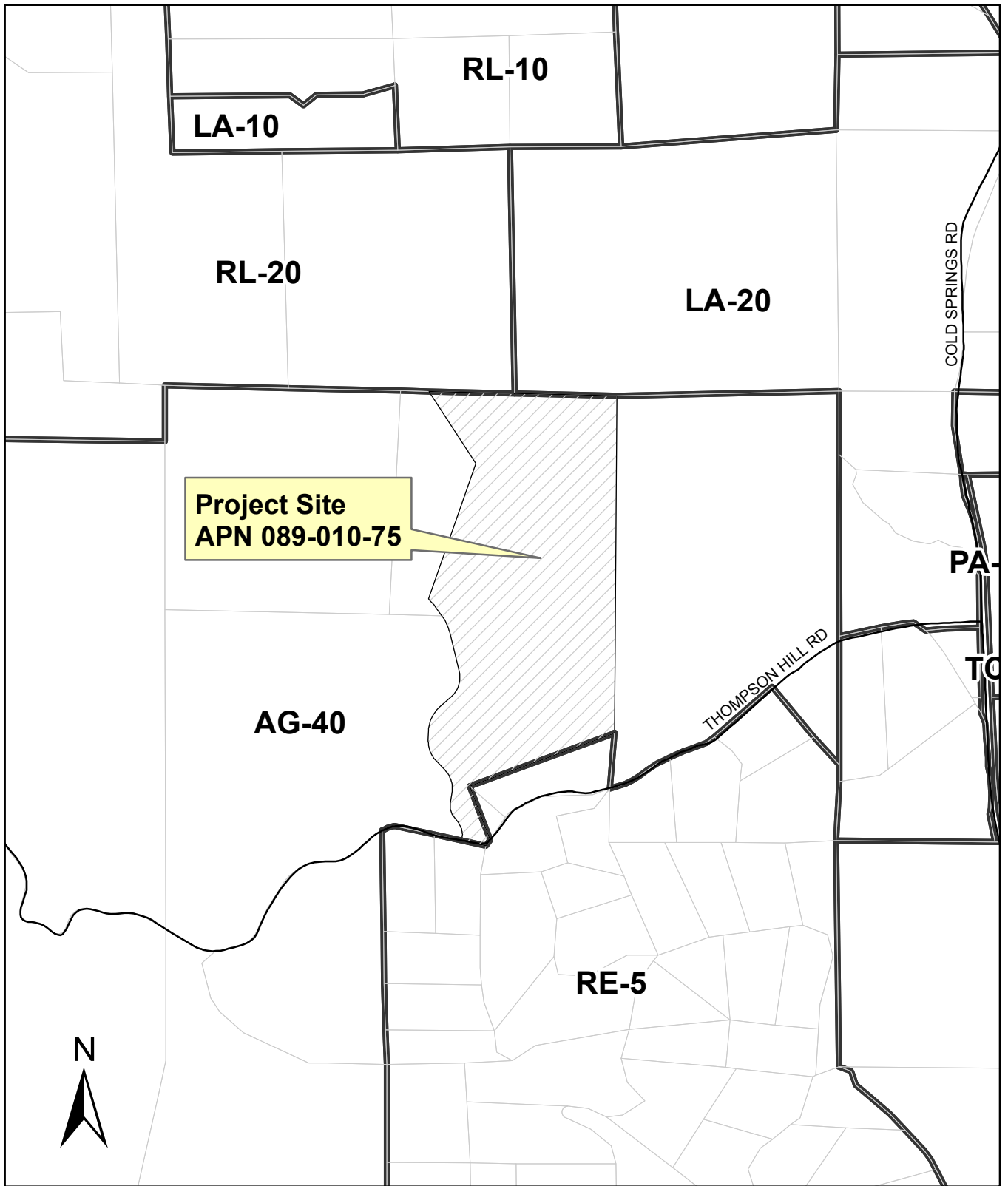

GENERAL CONSTRUCTION NOTES:

- PLANS ARE INTENDED TO BE DIAGRAMMATIC OUTLINE ONLY, UNLESS NOTED OTHERWISE. THE WORK SHALL INCLUDE FURNISHING MATERIALS, EQUIPMENT, APPURTENANCES AND LABOR NECESSARY TO COMPLETE ALL INSTALLATIONS AS INDICATED ON THE DRAWINGS.
- THE CONTRACTOR SHALL OBTAIN, IN WRITING, AUTHORIZATION TO PROCEED BEFORE STARTING WORK ON ANY ITEM NOT CLEARLY DEFINED OR IDENTIFIED BY THE CONTRACT DOCUMENTS.
- CONTRACTOR SHALL CONTACT USA (UNDERGROUND SERVICE ALERT) AT (800) 227-2600, FOR UTILITY LOCATIONS, 48 HOURS BEFORE PROCEEDING WITH ANY EXCAVATION, SITE WORK OR CONSTRUCTION.
- THE CONTRACTOR SHALL INSTALL ALL EQUIPMENT AND MATERIALS IN ACCORDANCE WITH MANUFACTURER'S RECOMMENDATIONS UNLESS SPECIFICALLY INDICATED OTHERWISE, OR WHERE LOCAL CODES OR REGULATIONS TAKE PRECEDENCE.
- ALL CONSTRUCTION SHALL BE IN ACCORDANCE WITH THE CBC / UBC'S REQUIREMENTS REGARDING EARTHQUAKE RESISTANCE, FOR, BUT NOT LIMITED TO, PIPING, LIGHT FIXTURES, CEILING GRID, INTERIOR PARTITIONS, AND MECHANICAL EQUIPMENT. ALL WORK MUST COMPLY WITH LOCAL EARTHQUAKE CODES AND REGULATIONS.
- REPRESENTATIONS OF TRUE NORTH, OTHER THAN THOSE FOUND ON THE PLOT OF SURVEY DRAWINGS, SHALL NOT BE USED TO IDENTIFY OR ESTABLISH BEARING OF TRUE NORTH AT THE SITE. THE CONTRACTOR SHALL RELY SOLELY ON THE PLOT OF SURVEY DRAWING AND ANY SURVEYOR'S MARKINGS AT THE SITE FOR THE ESTABLISHMENT OF TRUE NORTH, AND SHALL NOTIFY THE ARCHITECT / ENGINEER PRIOR TO PROCEEDING WITH THE WORK IF ANY DISCREPANCY IS FOUND BETWEEN THE VARIOUS ELEMENTS OF THE WORKING DRAWINGS AND THE TRUE NORTH ORIENTATION AS DEPICTED ON THE CIVIL SURVEY. THE CONTRACTOR SHALL ASSUME SOLE LIABILITY FOR ANY FAILURE TO NOTIFY THE ARCHITECT / ENGINEER.
- THE BUILDING DEPARTMENT ISSUING THE PERMITS SHALL BE NOTIFIED AT LEAST TWO WORKING DAYS PRIOR TO THE COMMENCEMENT OF WORK, OR AS OTHERWISE STIPULATED BY THE CODE ENFORCEMENT OFFICIAL HAVING JURISDICTION.
- DO NOT EXCAVATE OR DISTURB BEYOND THE PROPERTY LINES OR LEASE LINES, UNLESS OTHERWISE NOTED.
- ALL EXISTING UTILITIES, FACILITIES, CONDITIONS, AND THEIR DIMENSIONS SHOWN ON THE PLAN HAVE BEEN PLOTTED FROM AVAILABLE RECORDS. THE ARCHITECT / ENGINEER AND THE OWNER ASSUME NO RESPONSIBILITY WHATSOEVER AS TO THE SUFFICIENCY OR THE ACCURACY OF THE INFORMATION SHOWN ON THE PLANS, OR THE MANNER OF THEIR REMOVAL OR ADJUSTMENT. CONTRACTORS SHALL BE RESPONSIBLE FOR DETERMINING EXACT LOCATION OF ALL EXISTING UTILITIES AND FACILITIES PRIOR TO START OF CONSTRUCTION. CONTRACTORS SHALL ALSO OBTAIN FROM EACH UTILITY COMPANY DETAILED INFORMATION RELATIVE TO WORKING SCHEDULES AND METHODS OF REMOVING OR ADJUSTING EXISTING UTILITIES.
- CONTRACTOR SHALL VERIFY ALL EXISTING UTILITIES, BOTH HORIZONTAL AND VERTICALLY, PRIOR TO THE START OF CONSTRUCTION. ANY DISCREPANCIES OR DOUBTS AS TO THE INTERPRETATION OF PLANS SHOULD BE IMMEDIATELY REPORTED TO THE ARCHITECT / ENGINEER FOR RESOLUTION AND INSTRUCTION, AND NO FURTHER WORK SHALL BE PERFORMED UNTIL THE DISCREPANCY IS CHECKED AND CORRECTED BY THE ARCHITECT / ENGINEER. FAILURE TO SECURE SUCH INSTRUCTION MEANS CONTRACTOR WILL HAVE WORKED AT HIS/HER OWN RISK AND EXPENSE.
- ALL NEW AND EXISTING UTILITY STRUCTURES ON SITE AND IN AREAS TO BE DISTURBED BY CONSTRUCTION SHALL BE ADJUSTED TO FINISH DIMENSIONS PRIOR TO FINAL INSPECTION OF WORK.
- ALL DRAIN AND/OR FIELD TILE ENCOUNTERED / DISTURBED DURING CONSTRUCTION SHALL BE RETURNED TO ITS ORIGINAL CONDITION PRIOR TO COMPLETION OF WORK. SIZE, LOCATION AND TYPE OF ANY UNDERGROUND UTILITIES OR IMPROVEMENTS SHALL BE ACCURATELY NOTED AND PLACED ON "AS-BUILT" DRAWINGS BY GENERAL CONTRACTOR, AND ISSUED TO THE ARCHITECT / ENGINEER AT COMPLETION OF PROJECT.
- ALL TEMPORARY EXCAVATIONS FOR THE INSTALLATION OF FOUNDATIONS, UTILITIES, ETC., SHALL BE PROPERLY LAID BACK OR BRACED IN ACCORDANCE WITH CORRECT OCCUPATIONAL SAFETY AND HEALTH ADMINISTRATION (OSHA) REQUIREMENTS.
- INCLUDE MISC. ITEMS PER AT&T SPECIFICATIONS

EXHIBIT G

APPLICABLE CODES, REGULATIONS AND STANDARDS:

SUBCONTRACTOR'S WORK SHALL COMPLY WITH ALL APPLICABLE NATIONAL, STATE, AND LOCAL CODES AS ADOPTED BY THE LOCAL AUTHORITY HAVING JURISDICTION (AHJ) FOR THE LOCATION.

THE EDITION OF THE AHJ ADOPTED CODES AND STANDARDS IN EFFECT ON THE DATE OF CONTRACT AWARD SHALL GOVERN THE DESIGN.

SUBCONTRACTOR'S WORK SHALL COMPLY WITH THE LATEST EDITION OF THE FOLLOWING STANDARDS:

- AMERICAN CONCRETE INSTITUTE (ACI) 318, BUILDING CODE REQUIREMENTS FOR STRUCTURAL CONCRETE
- AMERICAN INSTITUTE OF STEEL CONSTRUCTION (AISC), MANUAL OF STEEL CONSTRUCTION, ASD, NINTH EDITION
- TELECOMMUNICATIONS INDUSTRY ASSOCIATION (TIA) 222-G, STRUCTURAL STANDARD FOR STRUCTURAL ANTENNA TOWER AND ANTENNA SUPPORTING STRUCTURES
- INSTITUTE FOR ELECTRICAL AND ELECTRONICS ENGINEERS (IEEE) 81, GUIDE FOR MEASURING EARTH RESISTIVITY, GROUND IMPEDANCE, AND EARTH SURFACE POTENTIALS OF A GROUND SYSTEM IEEE 1100 (1999) RECOMMENDED PRACTICE FOR POWERING AND GROUNDING OF ELECTRICAL EQUIPMENT.
- IEEE C62.41, RECOMMENDED PRACTICES ON SURGE VOLTAGES IN LOW VOLTAGE AC POWER CIRCUITS (FOR LOCATION CATEGORY "C3" AND "HIGH SYSTEM EXPOSURE")

TIA 607 COMMERCIAL BUILDING GROUNDING AND BONDING REQUIREMENTS FOR TELECOMMUNICATIONS TELCORDIA GR-63 NETWORK EQUIPMENT-BUILDING SYSTEM (NEBS): PHYSICAL PROTECTION
 TELCORDIA GR-347 CENTRAL OFFICE POWER WIRING
 TELCORDIA GR-1275 GENERAL INSTALLATION REQUIREMENTS
 TELCORDIA GR-1503 COAXIAL CABLE CONNECTIONS

ANY AND ALL OTHER LOCAL & STATE LAWS AND REGULATIONS

FOR ANY CONFLICTS BETWEEN SECTIONS OF LISTED CODES AND STANDARDS REGARDING MATERIAL, METHODS OF CONSTRUCTION, OR OTHER REQUIREMENTS, THE MOST RESTRICTIVE SHALL GOVERN. WHERE THERE IS CONFLICT BETWEEN A GENERAL REQUIREMENT AND A SPECIFIC REQUIREMENT, THE SPECIFIC REQUIREMENT SHALL GOVERN.

ABBREVIATIONS

A.B.	ANCHOR BOLT	IN. (")	INCH(ES)
ABV.	ABOVE	INT.	INTERIOR
ACCA	ANTENNA CABLE COVER ASSEMBLY	LB.(#)	POUND(S)
ADD'L	ADDITIONAL	LAG BOLT	LAG BOLTS
A.F.F.	ABOVE FINISHED FLOOR	L.F.	LINEAR FEET (FOOT)
A.F.G.	ABOVE FINISHED GRADE	L.	LONG(ITUDINAL)
ALUM.	ALUMINUM	MAS.	MASONRY
ALT.	ALTERNATE	MAX.	MAXIMUM
ANT.	ANTENNA	M.B.	MACHINE BOLT
APPRX.	APPROXIMATE(LY)	MECH.	MECHANICAL
ARCH.	ARCHITECT(URAL)	MFR.	MANUFACTURER
AWG.	AMERICAN WIRE GAUGE	MIN.	MINIMUM
BLDG.	BUILDING	MISC.	MISCELLANEOUS
BLK.	BLOCK	MTL.	METAL
BLKG.	BLOCKING	(N)	NEW
BM.	BEAM	NO.(#)	NUMBER
B.N.	BOUNDARY NAILING	N.T.S.	NOT TO SCALE
BTCW.	BARE TINNED COPPER WIRE	O.C.	ON CENTER
B.O.F.	BOTTOM OF FOOTING	OPNG.	OPENING
B/U	BACK-UP CABINET	P/C	PRECAST CONCRETE
CAB.	CABINET	PCS	PERSONAL COMMUNICATION SERVICES
CANT.	CANTILEVER(ED)	PLY.	PLYWOOD
C.I.P.	CAST IN PLACE	PPC	POWER PROTECTION CABINET
CLG.	CEILING	PRC	PRIMARY RADIO CABINET
CLR.	CLEAR	P.S.F.	POUNDS PER SQUARE FOOT
COL.	COLUMN	P.S.I.	POUNDS PER SQUARE INCH
CONC.	CONCRETE	P.T.	PRESSURE TREATED
CONN.	CONNECTION(OR)	PWR.	POWER (CABINET)
CONSTR.	CONSTRUCTION	QTY.	QUANTITY
CONT.	CONTINUOUS	RAD.(R)	RADIUS
d	PENNY (NAILS)	REF.	REFERENCE
DBL.	DOUBLE	REINF.	REINFORCEMENT(ING)
DEPT.	DEPARTMENT	REQ'D/	REQUIRED
D.F.	DOUGLAS FIR	RGS.	RIGID GALVANIZED STEEL
DIA.	DIAMETER	SCH.	SCHEDULE
DIAG.	DIAGONAL	SHT.	SHEET
DIM.	DIMENSION	SIM.	SIMILAR
DWG.	DRAWING(S)	SPEC.	SPECIFICATIONS
DWL.	DOWEL(S)	SQ.	SQUARE
EA.	EACH	S.S.	STAINLESS STEEL
EL.	ELEVATION	STD.	STANDARD
ELEC.	ELECTRICAL	STL.	STEEL
ELEV.	ELEVATOR	STRUC.	STRUCTURAL
EMT.	ELECTRICAL METALLIC TUBING	TEMP.	TEMPORARY
E.N.	EDGE NAIL	THK.	THICK(NESS)
ENG.	ENGINEER	T.N.	TOE NAIL
EQ.	EQUAL	T.O.A.	TOP OF ANTENNA
EXP.	EXPANSION	T.O.C.	TOP OF CURB
EXST.(E)	EXISTING	T.O.F.	TOP OF FOUNDATION
EXT.	EXTERIOR	T.O.P.	TOP OF PLATE (PARAPET)
FAB.	FABRICATION(OR)	T.O.S.	TOP OF STEEL
F.F.	FINISH FLOOR	T.O.W.	TOP OF WALL
F.G.	FINISH GRADE	TYP.	TYPICAL
FIN.	FINISHED	U.G.	UNDER GROUND
FLR.	FLOOR	U.L.	UNDERWRITERS LABORATORY
FDN.	FOUNDATION	U.N.O.	UNLESS NOTED OTHERWISE
F.O.C.	FACE OF CONCRETE	V.I.F.	VERIFY IN FIELD
F.O.M.	FACE OF MASONRY	W	WIDE (WIDTH)
F.O.S.	FACE OF STUD	w/	WITH
F.O.W.	FACE OF WALL	WD.	WOOD
F.S.	FINISH SURFACE	W.P.	WEATHERPROOF
FT. (')	FOOT (FEET)	WT.	WEIGHT
FIG.	FOOTING	CL	CENTERLINE
G.	GROWTH (CABINET)	EL	PLATE, PROPERTY LINE
GA.	GAUGE		
GI.	GALVANIZE(D)		
G.F.I.	GROUND FAULT CIRCUIT INTERRUPTER		
GLB. (GLU-LAM)	GLUE LAMINATED BEAM		
GPS	GLOBAL POSITIONING SYSTEM		
GRND.	GROUND		
HDR.	HEADER		
HGR.	HANGER		
HT.	HEIGHT		
ICGB.	ISOLATED COPPER GROUND BUS		

SYMBOLS LEGEND

	BLDG. SECTION		GROUT OR PLASTER
	WALL SECTION		(E) BRICK
	DETAIL		(E) MASONRY
	ELEVATION		CONCRETE
	DOOR SYMBOL		EARTH
	WINDOW SYMBOL		GRAVEL
	TILT-UP PANEL MARK		PLYWOOD
	PROPERTY LINE		SAND
	CENTERLINE		PLYWOOD
	ELEVATION DATUM		SAND
	GRID/COLUMN LINE		(E) STEEL
	KEYNOTE, DIMENSION ITEM		MATCH LINE
	KEYNOTE, CONSTRUCTION ITEM		GROUND CONDUCTOR
	WALL TYPE MARK		OVERHEAD SERVICE CONDUCTORS
	ROOM NAME		TELEPHONE CONDUIT
	ROOM NUMBER		POWER CONDUIT
			COAXIAL CABLE
			CHAIN LINK FENCE
			WOOD FENCE
			(P) ANTENNA
			(P) RRU
			(P) DC SURGE SUPPRESSION
			(F) ANTENNA
			(F) RRU
			(E) EQUIPMENT

Issued For:

CVL00330
 LOTUS ROAD

5621 BIG SKY RANCH RD.
 PLACERVILLE, CA 95667

PREPARED FOR



2600 Camino Ramon
 San Ramon, California 94583

Vendor:



AT&T SITE NO: CVL00330

PROJECT NO: 162.2196

DRAWN BY: MWS

CHECKED BY: TST

REV	DATE	DESCRIPTION
1	09/11/18	100% ZD Rev 1
	06/01/18	100% ZD
	05/03/18	90% ZD

Licensee:

IT IS A VIOLATION OF LAW FOR ANY PERSON, UNLESS THEY ARE ACTING UNDER THE DIRECTION OF A LICENSED PROFESSIONAL ENGINEER, TO ALTER THIS DOCUMENT.

Architect:



SHEET TITLE:

GENERAL NOTES

SHEET NUMBER:

GN-1

THIS IS NOT A SITE SURVEY

ALL PROPERTY BOUNDARIES, ORIENTATION OF TRUE NORTH AND STREET HALF-WIDTHS HAVE BEEN OBTAINED FROM A TAX PARCEL MAP AND EXISTING DRAWINGS AND ARE APPROXIMATE.

NOTES:

1. NO GRADING OR PERMANENT CONSTRUCTION SHALL OCCUR WITHIN DRIP LINES OF TREES THAT ARE TO REMAIN WITHOUT ARBORIST APPROVAL.
2. PRIOR TO CONSTRUCTION, GENERAL CONTRACTOR TO CONTACT DIGALERT TO MARK OUT EXISTING UNDERGROUND UTILITIES. IN THE EVENT OF CONFLICTS, CONTRACTOR TO CONTACT PDC.

EXHIBIT G

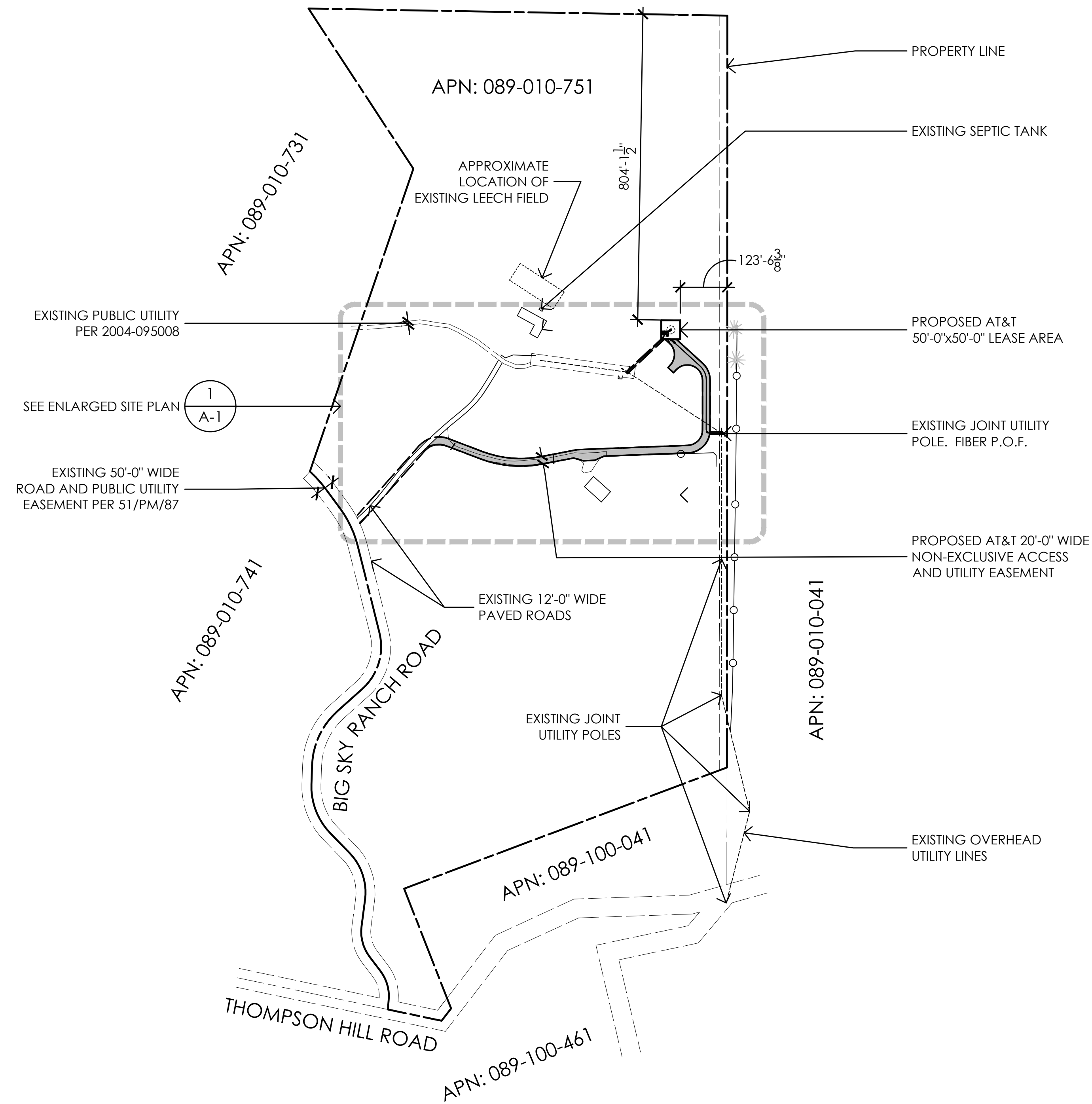

Issued For:

**CVL00330
LOTUS ROAD**

5621 BIG SKY RANCH RD.
PLACERVILLE, CA 95667

PREPARED FOR



2600 Camino Ramon
San Ramon, California 94583

Vendor:



AT&T SITE NO: CVL00330

PROJECT NO: 162.2196

DRAWN BY: MWS

CHECKED BY: TST

REV	DATE	DESCRIPTION
1	09/11/18	100% ZD Rev 1
	06/01/18	100% ZD
	05/03/18	90% ZD

Licensee:

IT IS A VIOLATION OF LAW FOR ANY PERSON, UNLESS THEY ARE ACTING UNDER THE DIRECTION OF A LICENSED PROFESSIONAL ENGINEER, TO ALTER THIS DOCUMENT.

Architect:



SHEET TITLE:

**OVERALL
SITE PLAN**

SHEET NUMBER:

A-0

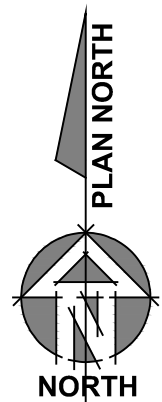

1 OVERALL SITE PLAN

1"=200'

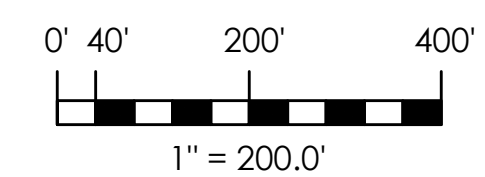

THIS IS NOT A SITE SURVEY

ALL PROPERTY BOUNDARIES, ORIENTATION OF TRUE NORTH AND STREET HALF-WIDTHS HAVE BEEN OBTAINED FROM A TAX PARCEL MAP AND EXISTING DRAWINGS AND ARE APPROXIMATE.

NOTES:

1. NO GRADING OR PERMANENT CONSTRUCTION SHALL OCCUR WITHIN DRIP LINES OF TREES THAT ARE TO REMAIN WITHOUT ARBORIST APPROVAL.
2. PRIOR TO CONSTRUCTION, GENERAL CONTRACTOR TO CONTACT DIGALERT TO MARK OUT EXISTING UNDERGROUND UTILITIES. IN THE EVENT OF CONFLICTS, CONTRACTOR TO CONTACT PDC.

APPROXIMATE LOCATION OF EXISTING LEACH FIELD

EXISTING SEPTIC TANK

EXISTING RESIDENCE

EXISTING P.U.E.

EXISTING P.U.E.
EXISTING OVERHEAD UTILITIES
EXISTING JOINT UTILITY POLE

PROPOSED AT&T 6'-0" WIDE UTILITY EASEMENT
PROPOSED AT&T UNDERGROUND POWER & TELCO (±150')
EXISTING JOINT UTILITY POLE W/ TRANSFORMER, PROPOSED AT&T POWER P.O.C.
EXISTING WELL

NOTE: ACCESS ROAD & LEASE AREA GRADING PLANS TO BE PROVIDED BY A LICENSED CIVIL ENGINEER

EQUIPMENT AREA PLAN 1 A-2

EXISTING PROPERTY LINE

EXISTING 20' POLE LINE EASEMENT

EXISTING 62'-0" TALL PINE TREE (1439' AMSL)

EXISTING 90'-0" TALL PINE TREE (1467' AMSL)

PROPOSED AT&T UNDERGROUND FIBER CONDUIT TO LEASE AREA

PROPOSED AT&T 17'x30' TRAFFIC RATED FIBER GROUND VAULTS EVERY 300' (OR AS REQUIRED) TO LEASE AREA (TYP.)

EXISTING OVERHEAD UTILITIES

EXISTING JOINT UTILITY POLE, FIBER P.O.F.

PROPOSED AT&T 6'-0" WIDE UTILITY EASEMENT

EXHIBIT G

EXISTING 12'-0" WIDE AC PAVED DRIVEWAY

398'-0¹/₄"

260'-6"

EXISTING 12'-0" WIDE GRAVEL ACCESS ROAD TO BE IMPROVED TO 20'-0" WIDE ALL WEATHER ACCESS ROAD

50'-0" TURN RADIUS

PROPOSED AT&T 20'-0" WIDE NON-EXCLUSIVE ACCESS & UTILITY EASEMENT

PROPOSED 10'-0" WIDE GRAVEL TURNOUT

EXISTING GRAVEL TURNOUT AT BARN

EXISTING BARN

25'-0" 30'-0" 25'-0"

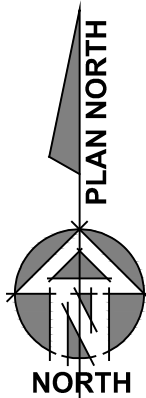
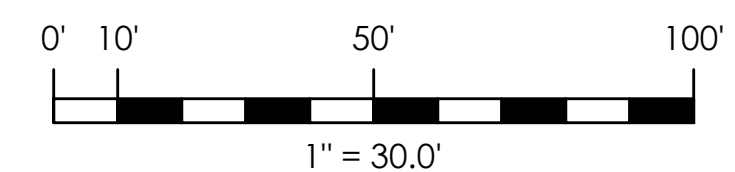

1 ENLARGED SITE PLAN
1"=30'

Issued For:

**CVL00330
LOTUS ROAD**

5621 BIG SKY RANCH RD.
PLACERVILLE, CA 95667

PREPARED FOR



2600 Camino Ramon
San Ramon, California 94583

Vendor:



COMPLETE
Wireless Consulting, Inc.

AT&T SITE NO: CVL00330

PROJECT NO: 162.2196

DRAWN BY: MWS

CHECKED BY: TST

REV	DATE	DESCRIPTION
1	09/11/18	100% ZD Rev 1
	06/01/18	100% ZD
	05/03/18	90% ZD

Licensee:

IT IS A VIOLATION OF LAW FOR ANY PERSON, UNLESS THEY ARE ACTING UNDER THE DIRECTION OF A LICENSED PROFESSIONAL ENGINEER, TO ALTER THIS DOCUMENT.

Architect:



MST ARCHITECTS
1520 River Park Drive
Sacramento, California 95815

SHEET TITLE:

**ENLARGED
SITE PLAN**

SHEET NUMBER:

A-1

NOTE: ACCESS ROAD & LEASE AREA GRADING PLANS TO BE PROVIDED BY A LICENSED CIVIL ENGINEER

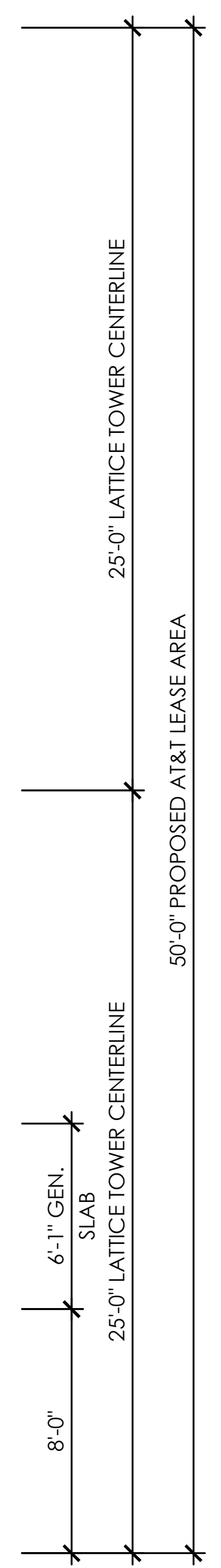
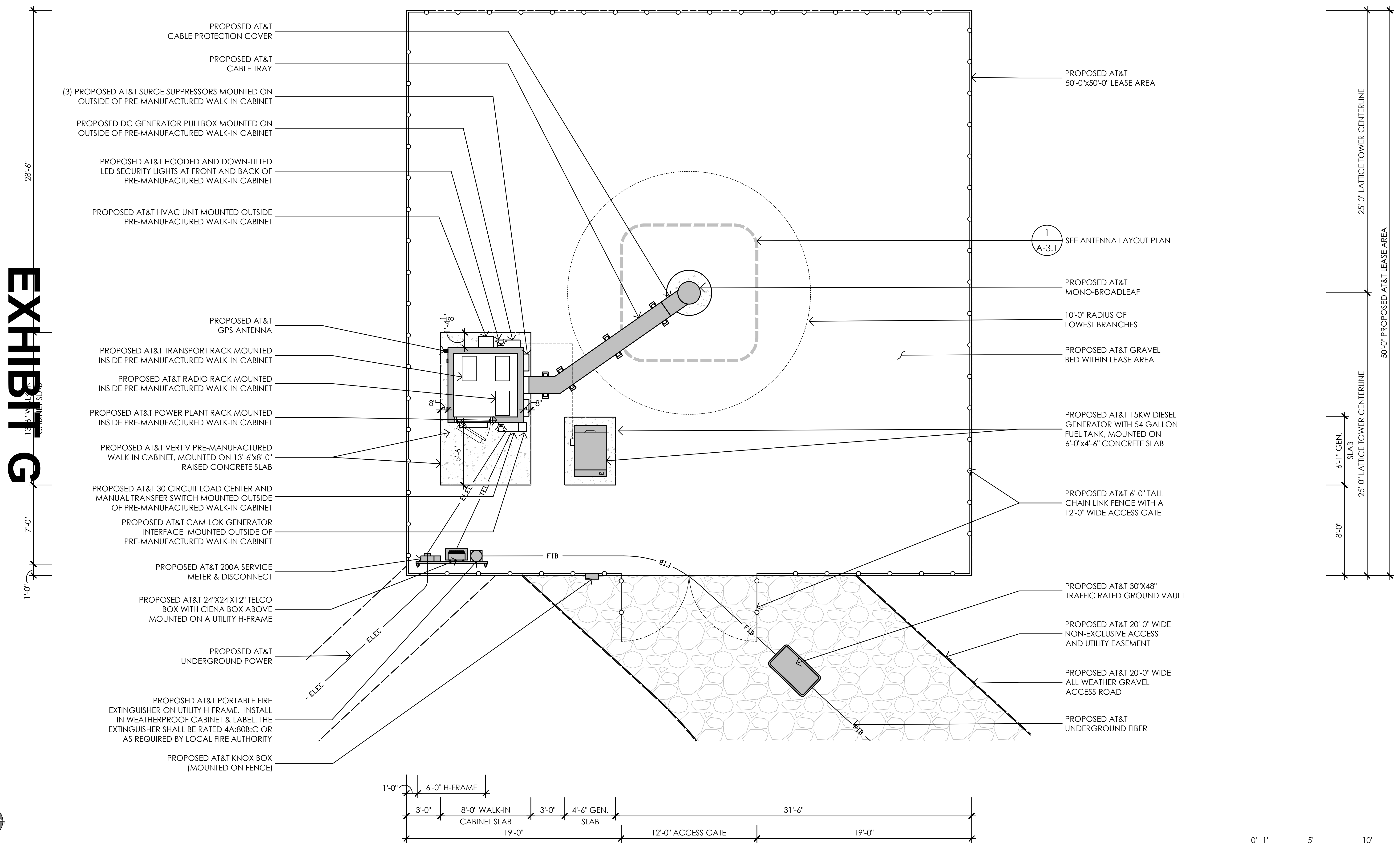
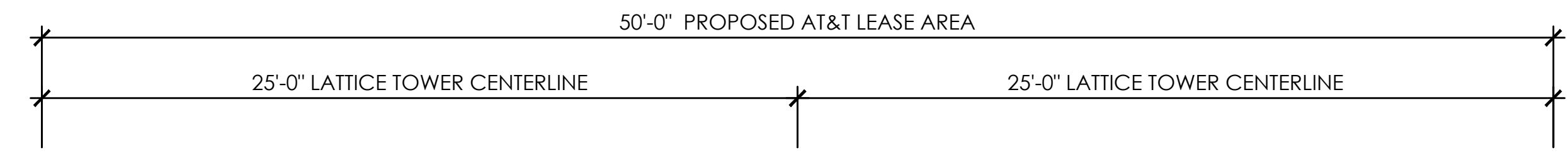
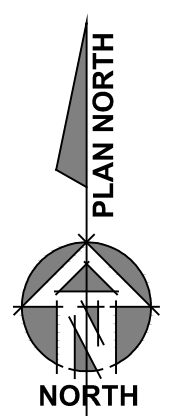
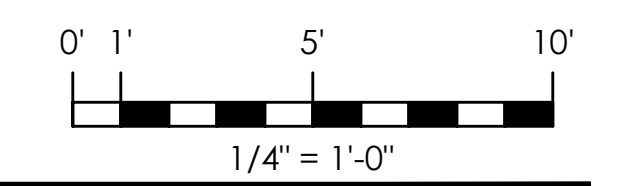

EXHIBIT G



1 EQUIPMENT AREA PLAN
1/4" = 1'-0"



Issued For:
CVL00330
LOTUS ROAD
5621 BIG SKY RANCH RD.
PLACERVILLE, CA 95667

PREPARED FOR

2600 Camino Ramon
San Ramon, California 94583

Vendor:

COMPLETE
Wireless Consulting, Inc.

AT&T SITE NO:	CVL00330
PROJECT NO:	162.2196
DRAWN BY:	MWS
CHECKED BY:	TST

REV	DATE	DESCRIPTION
1	09/11/18	100% ZD Rev 1
	06/01/18	100% ZD
	05/03/18	90% ZD

Licensee:

IT IS A VIOLATION OF LAW FOR ANY PERSON, UNLESS THEY ARE ACTING UNDER THE DIRECTION OF A LICENSED PROFESSIONAL ENGINEER, TO ALTER THIS DOCUMENT.

Architect:

MST ARCHITECTS
1520 River Park Drive
Sacramento, California 95815

SHEET TITLE:
EQUIPMENT AREA PLAN

SHEET NUMBER:
A-2

RF SCHEDULE										
SECTOR	ANTENNA MODEL NO.	AZIMUTH	CENTERLINE	RRU	TMA	FIBER LENGTH	COAX LENGTH	COAX DIA.	NO. OF RRU'S	
A L P H A	A1	KATHREIN 800-10965K	10°	±100'-0"	(1) 4449 B5/B12 / (1) 8843 B25/B66A	-	±150'-0"	-	-	2
	A2	KATHREIN 800-10965K	10°	±100'-0"	(1) 4449 B5/B12 / (1) 8843 B25/B66A	-	±150'-0"	-	-	2
	A3	KATHREIN 800-10965K	10°	±90'-0"	(1) 4478 B14 / (1) 4415 B25	-	±150'-0"	-	-	2
	A4	CCI BSA-M65R-BUU-H6	0°	±90'-0"	(2) RRUS-32	-	±150'-0"	-	-	2
B E T A	B1	KATHREIN 800-10965K	240°	±100'-0"	(1) 4449 B5/B12 / (1) 8843 B25/B66A	-	±150'-0"	-	-	2
	B2	KATHREIN 800-10965K	240°	±100'-0"	(1) 4449 B5/B12 / (1) 8843 B25/B66A	-	±150'-0"	-	-	2
	B3	KATHREIN 800-10965K	240°	±90'-0"	(1) 4478 B14 / (1) 4415 B25	-	±150'-0"	-	-	2
	B4	CCI BSA-M65R-BUU-H6	240°	±90'-0"	(1) RRUS-32	-	±150'-0"	-	-	1
G A M M A	C1	KATHREIN 800-10965K	120°	±100'-0"	(1) 4449 B5/B12 / (1) 8843 B25/B66A	-	±150'-0"	-	-	2
	C2	KATHREIN 800-10965K	120°	±100'-0"	(1) 4449 B5/B12 / (1) 8843 B25/B66A	-	±150'-0"	-	-	2
	C3	KATHREIN 800-10965K	120°	±90'-0"	(1) 4478 B14 / (1) 4415 B25	-	±150'-0"	-	-	2
	C4	CCI BSA-M65R-BUU-H6	120°	±90'-0"	(2) RRUS-32	-	±150'-0"	-	-	2

RF DATA SHEET v1.00.00 DATED 04/12/18

EQUIPMENT IS PRELIMINARY AND SUBJECT TO CHANGE.

NOTE: ANTENNA POSITIONS ARE LEFT TO RIGHT FROM FRONT OF ANTENNA

2 RF SCHEDULE
NO SCALE

Issued For:
CVL00330
LOTUS ROAD
5621 BIG SKY RANCH RD.
PLACERVILLE, CA 95667

PREPARED FOR

2600 Camino Ramon
San Ramon, California 94583

Vendor:

AT&T SITE NO: CVL00330
PROJECT NO: 162.2196
DRAWN BY: MWS
CHECKED BY: TST

REV	DATE	DESCRIPTION
1	09/11/18	100% ZD Rev 1
	06/01/18	100% ZD
	05/03/18	90% ZD

Licensee:

IT IS A VIOLATION OF LAW FOR ANY PERSON, UNLESS THEY ARE ACTING UNDER THE DIRECTION OF A LICENSED PROFESSIONAL ENGINEER, TO ALTER THIS DOCUMENT.

Architect:

1520 River Park Drive
Sacramento, California 95815

SHEET TITLE:
ANTENNA PLAN AND SCHEDULE

SHEET NUMBER:
A-3.1

EXHIBIT G

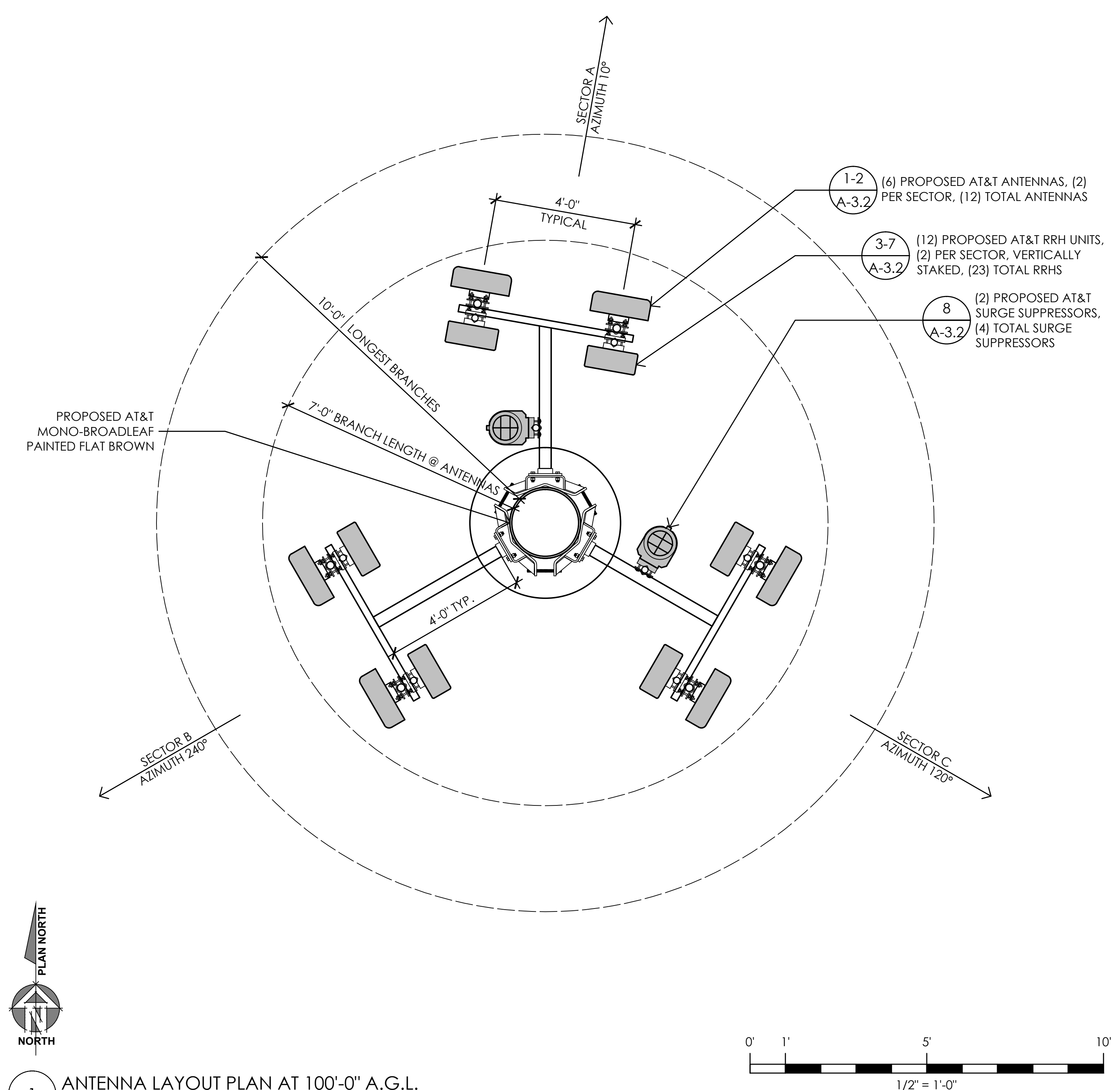
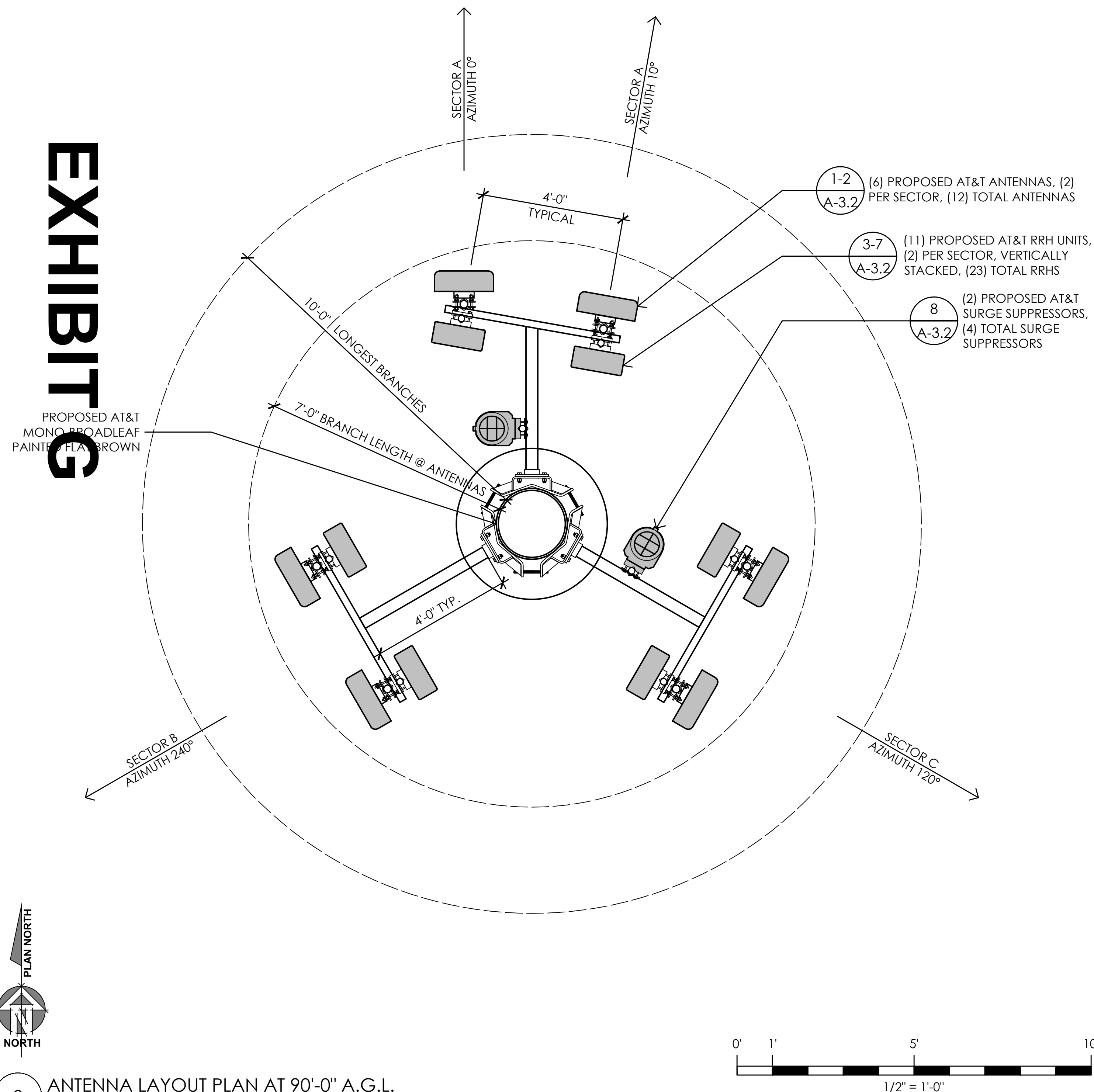

2 ANTENNA LAYOUT PLAN AT 90'-0" A.G.L.
1/2" = 1'-0"

1 ANTENNA LAYOUT PLAN AT 100'-0" A.G.L.
1/2" = 1'-0"

RAYCAP DC6-48-60-18-8F & DC6-48-60-0-8F SURGE SUPPRESSION SOLUTION

COLOR: BLACK/SILVER
 DIMENSIONS: 11" DIA X 27" TALL W/ 9" BASE
 WEIGHT: 50 LBS.± (INCLUDING MOUNTING HARDWARE)

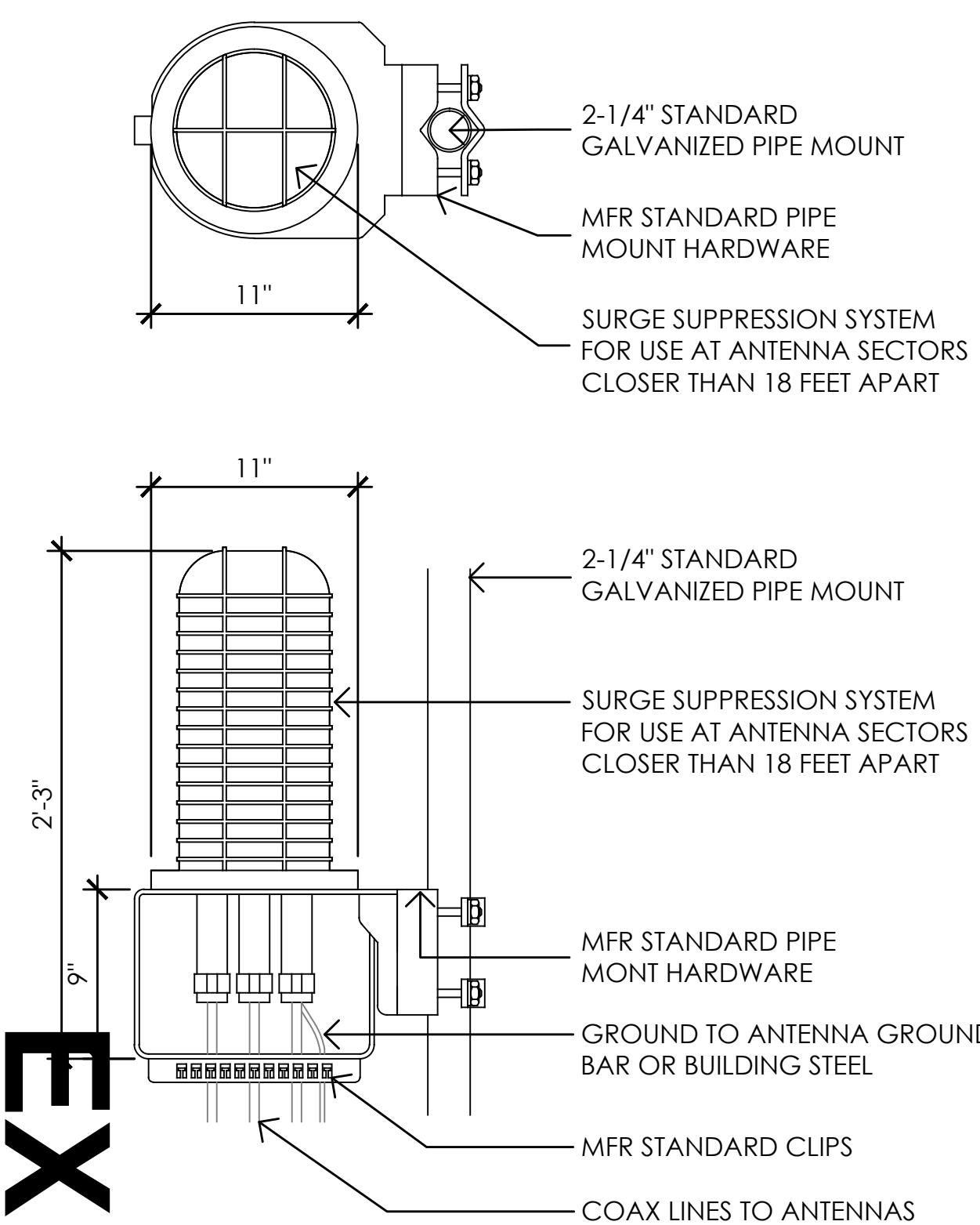

8 SURGE SUPPRESSION (SQUID)

EXHIBIT G

ERICSSON RADIO 8843 REMOTE RADIO UNIT

COLOR: WHITE
 DIMENSIONS: 28" TALL X 15" WIDE X 10" DEEP (INCLUDING SUNSHIELD)
 WEIGHT: 85 LBS.± (INCLUDING MOUNTING HARDWARE)

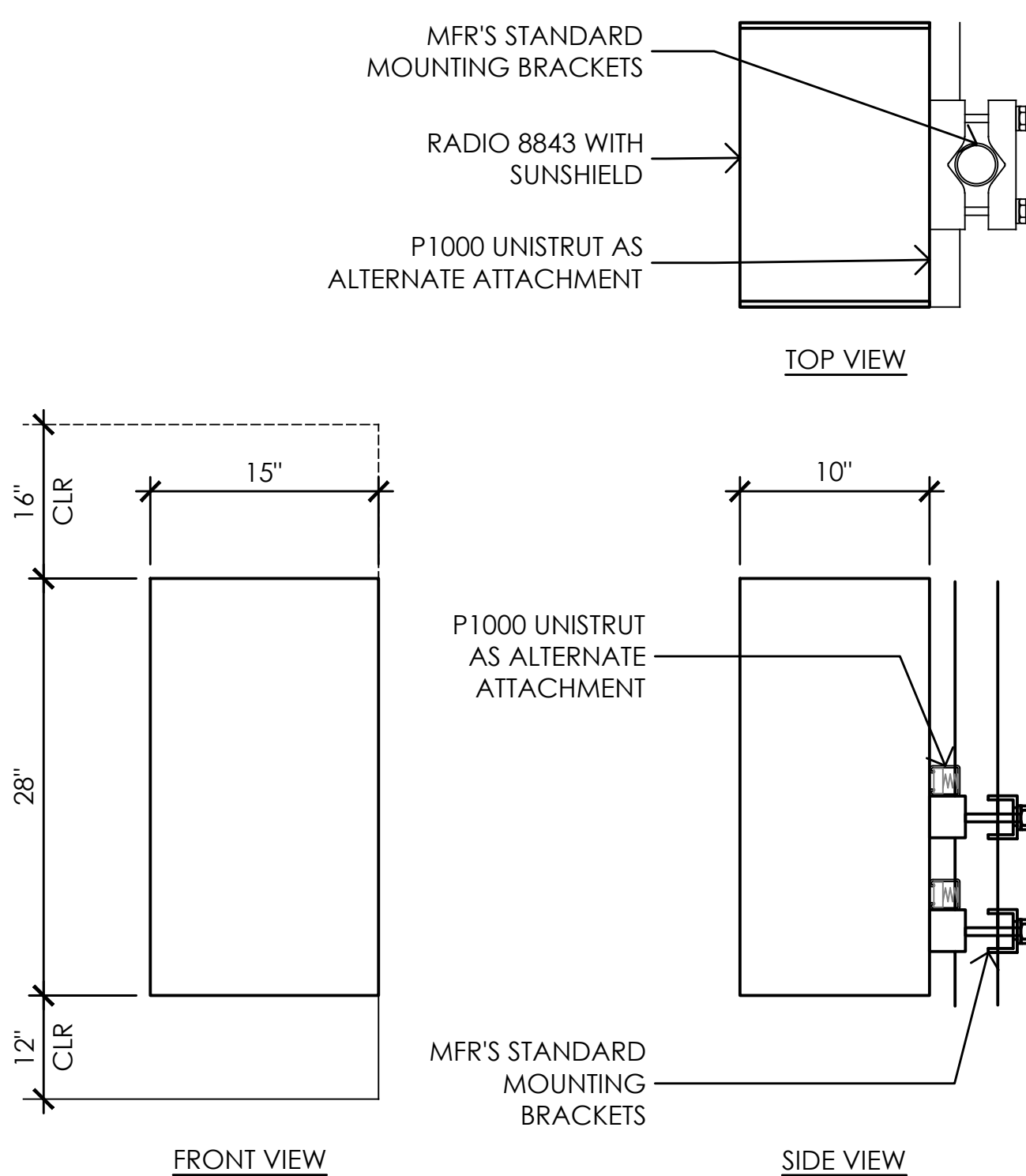

6 ERICSSON RADIO 8843 REMOTE RADIO UNIT

1-1/2" = 1'-0"

ERICSSON RADIO 4415 B25 REMOTE RADIO UNIT

COLOR: WHITE
 DIMENSIONS: 16.5" TALL X 13.4" WIDE X 5.9" DEEP (INCLUDING SUNSHIELD)
 WEIGHT: 46 LBS.± (INCLUDING MOUNTING HARDWARE)

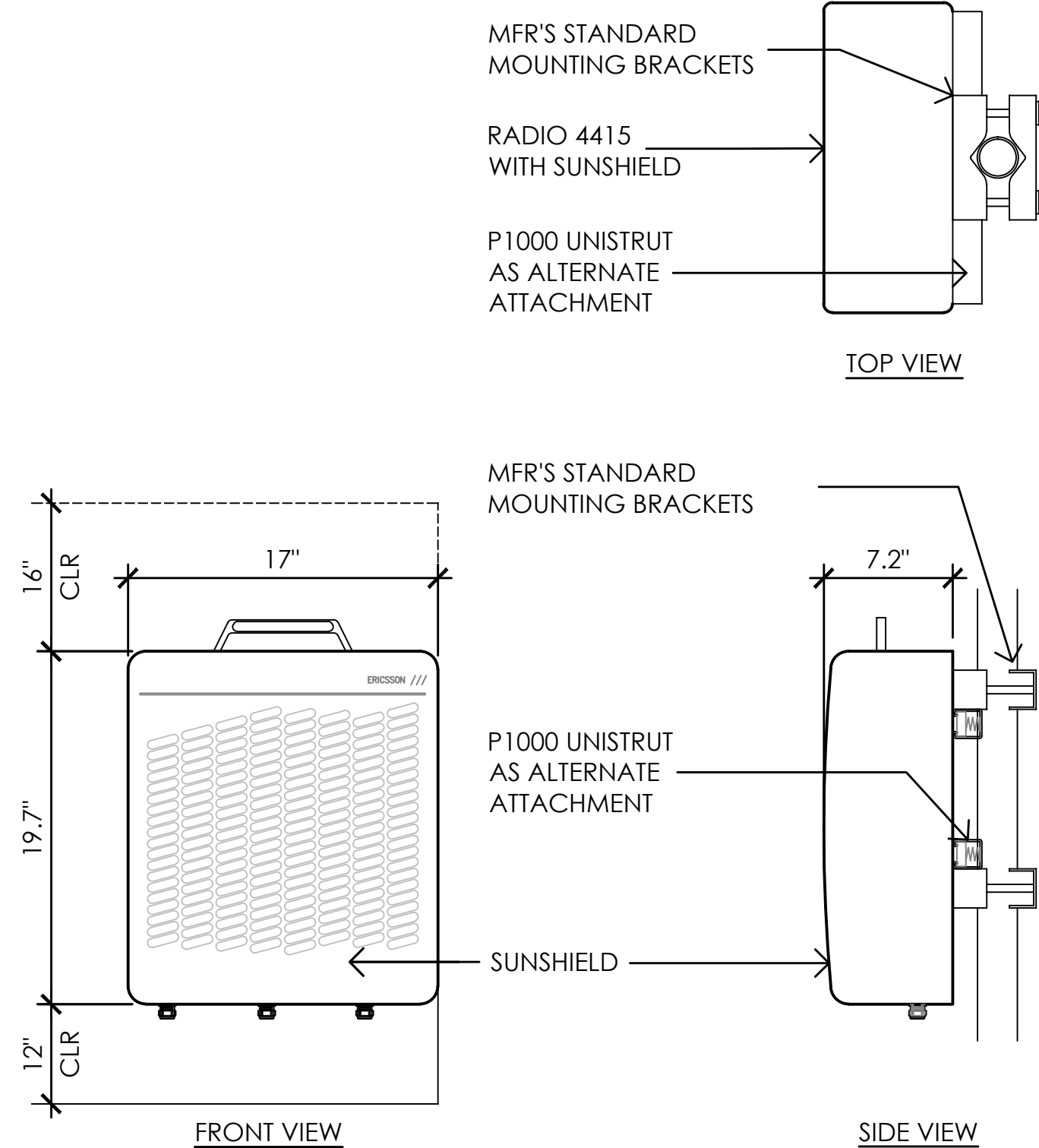

4 ERICSSON RADIO 4415 REMOTE RADIO UNIT

1-1/2" = 1'-0"

EQUIPMENT SUBJECT TO CHANGE

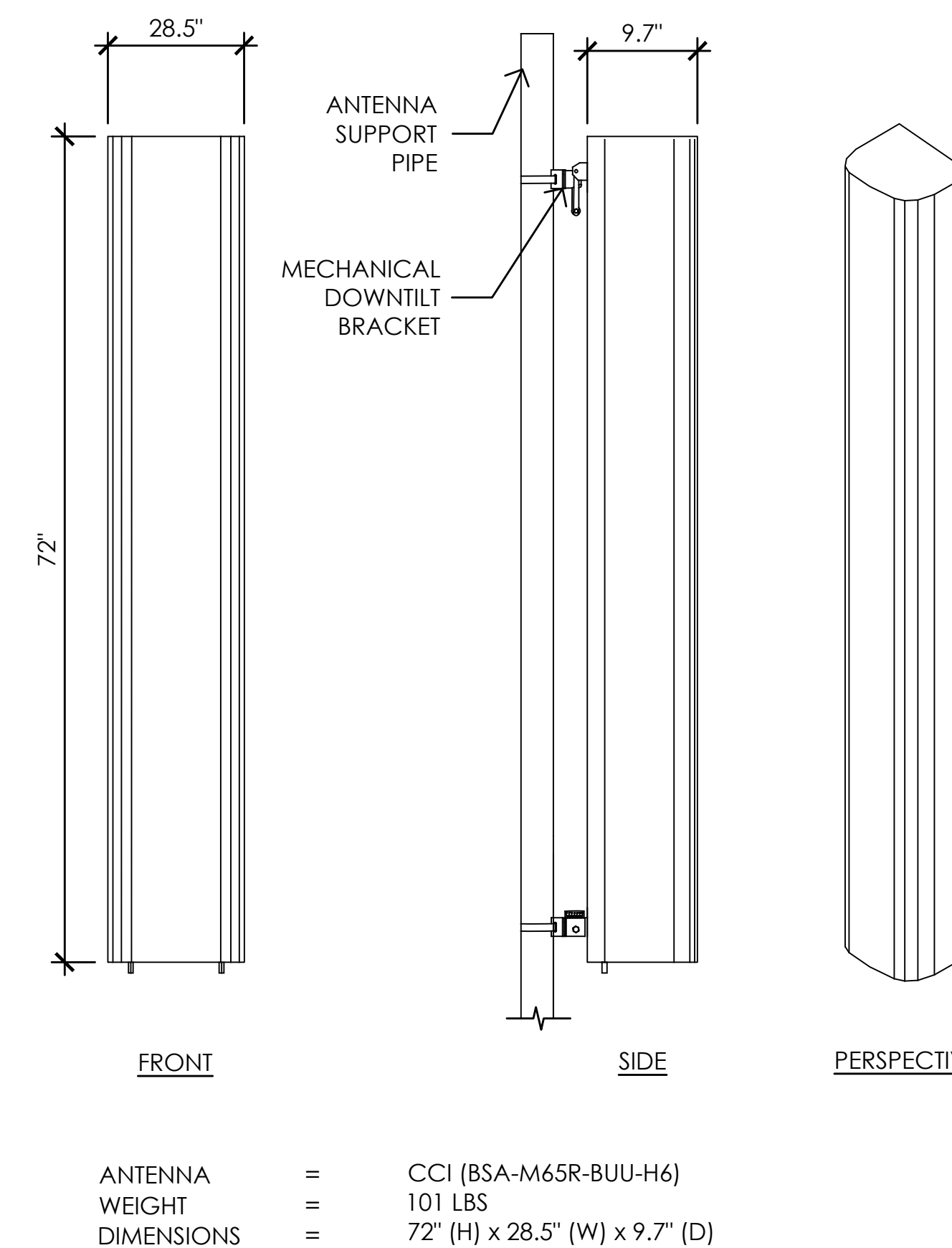

ANTENNA = CCI (BSA-M65R-BUU-H6)
 WEIGHT = 101 LBS
 DIMENSIONS = 72" (H) x 28.5" (W) x 9.7" (D)

2 PROPOSED ANTENNA SPEC

1" = 1'-0"

ERICSSON RADIO 4449 REMOTE RADIO UNIT

COLOR: WHITE
 DIMENSIONS: 28" TALL X 15" WIDE X 10" DEEP (INCLUDING SUNSHIELD)
 WEIGHT: 85 LBS.± (INCLUDING MOUNTING HARDWARE)

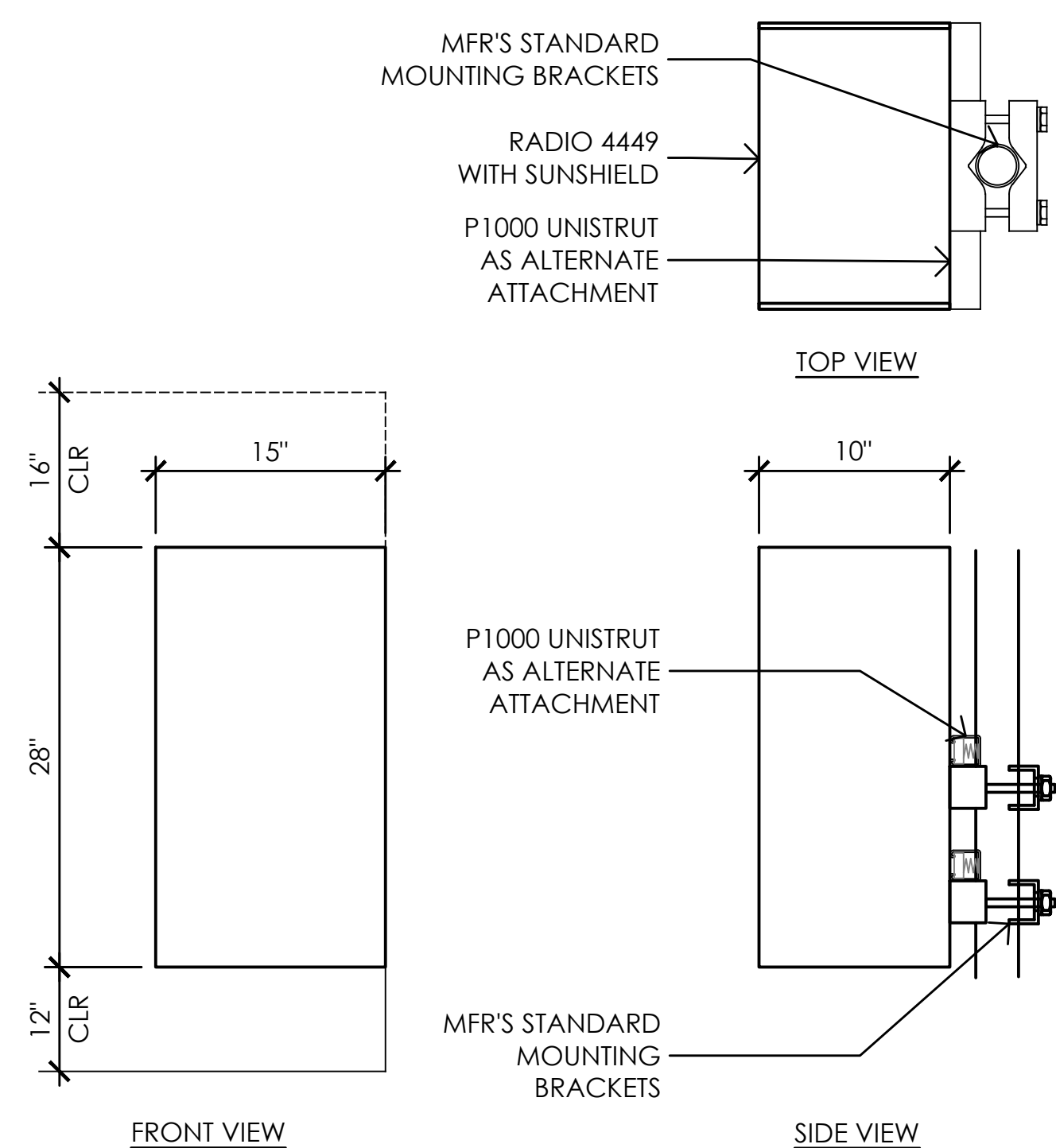

7 ERICSSON RADIO 4449 REMOTE RADIO UNIT

1-1/2" = 1'-0"

ERICSSON RADIO 4478 REMOTE RADIO UNIT

COLOR: WHITE
 DIMENSIONS: 19.7" TALL X 17" WIDE X 7.2" DEEP (INCLUDING SUNSHIELD)
 WEIGHT: 50 LBS.± (INCLUDING MOUNTING HARDWARE)

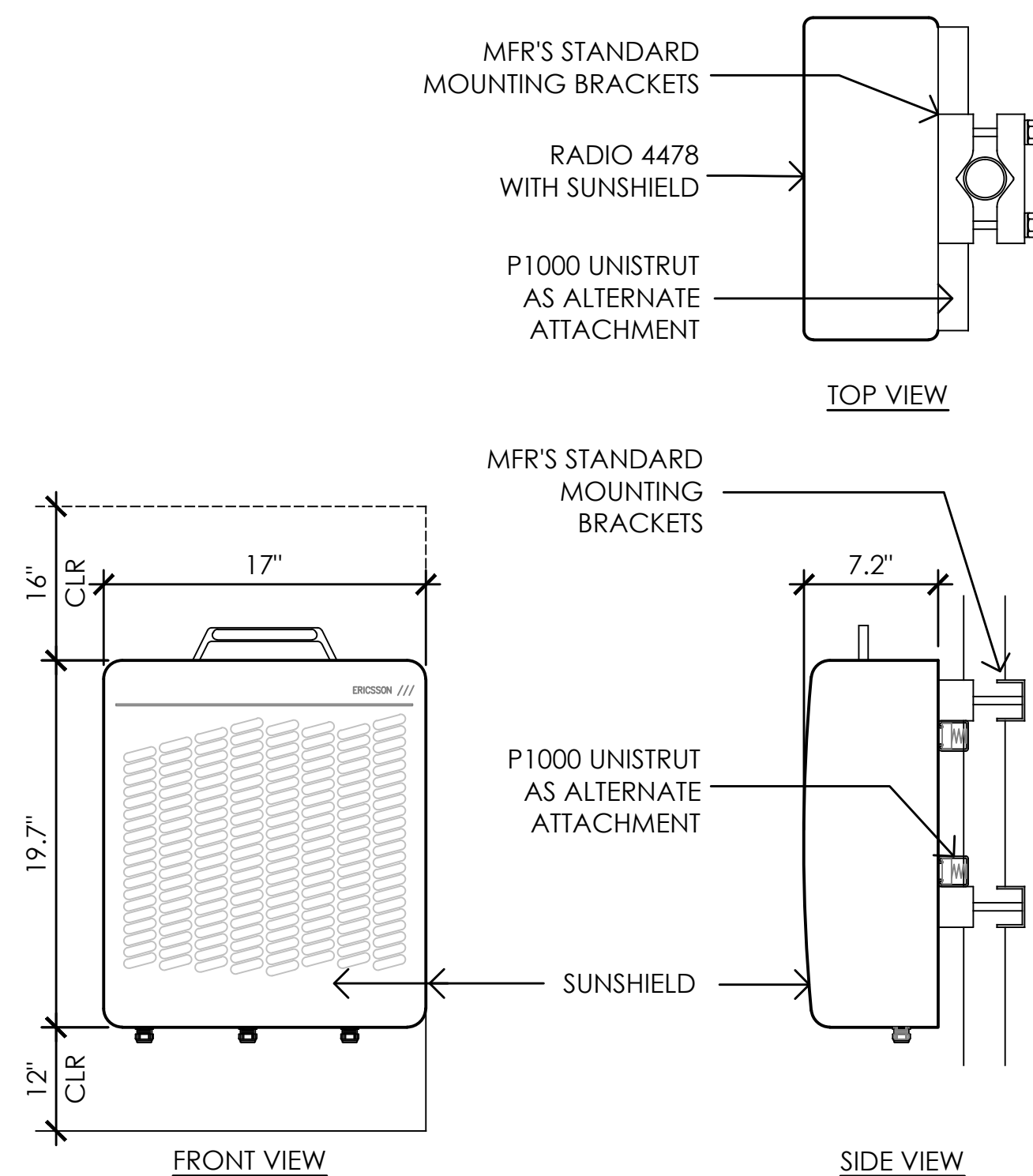

5 ERICSSON RADIO 4478 REMOTE RADIO UNIT

1-1/2" = 1'-0"

ERICSSON WCS RRH-32

MODEL: KRC161 423/1
 COLOR: WHITE
 DIMENSIONS: 29.9" TALL X 13.3" WIDE X 9.5" DEEP (INCLUDING SUNSHIELD)
 WEIGHT: 77 LBS.± (INCLUDING MOUNTING HARDWARE)

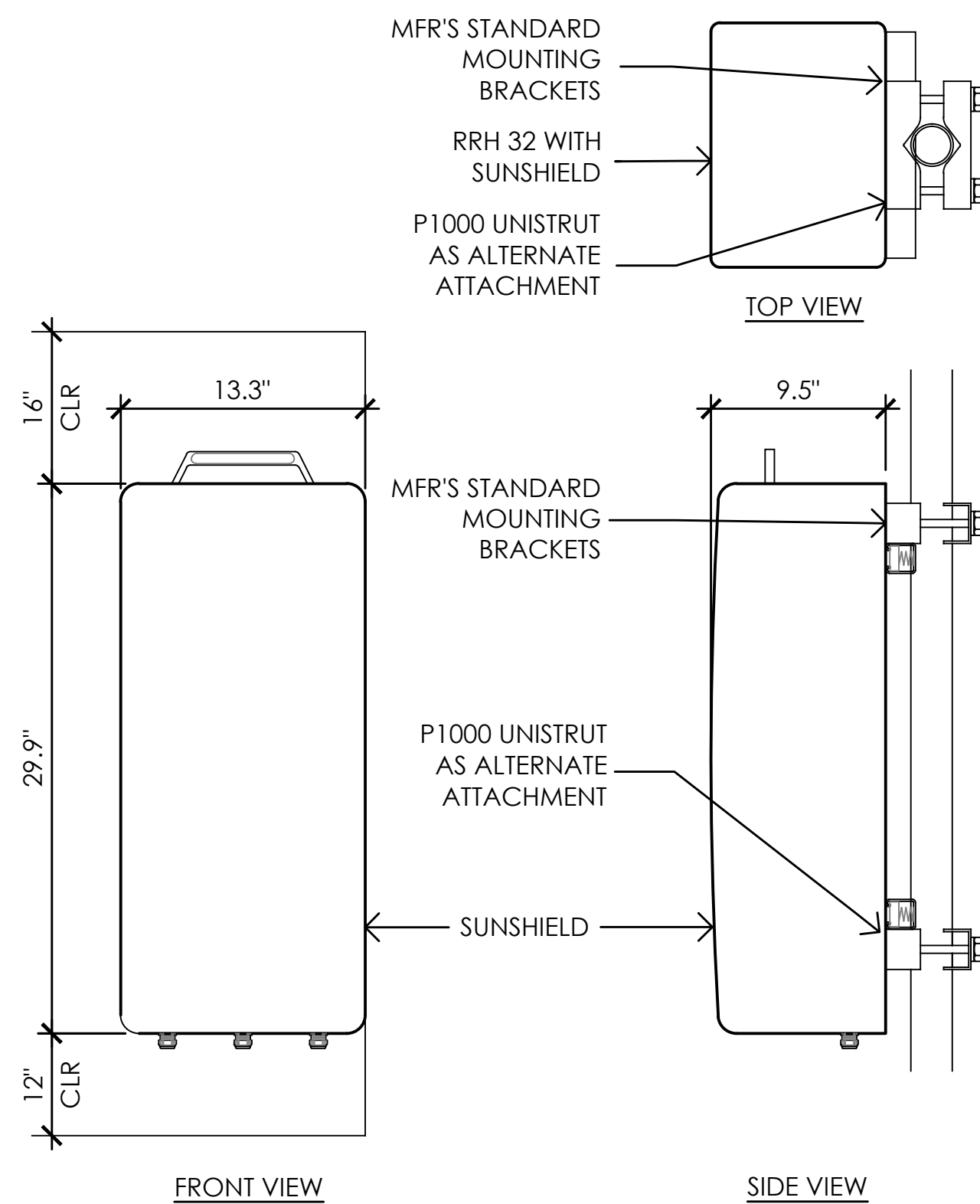

3 ERICSSON WCS RRH-32 REMOTE RADIO UNIT

1-1/2" = 1'-0"

EQUIPMENT SUBJECT TO CHANGE

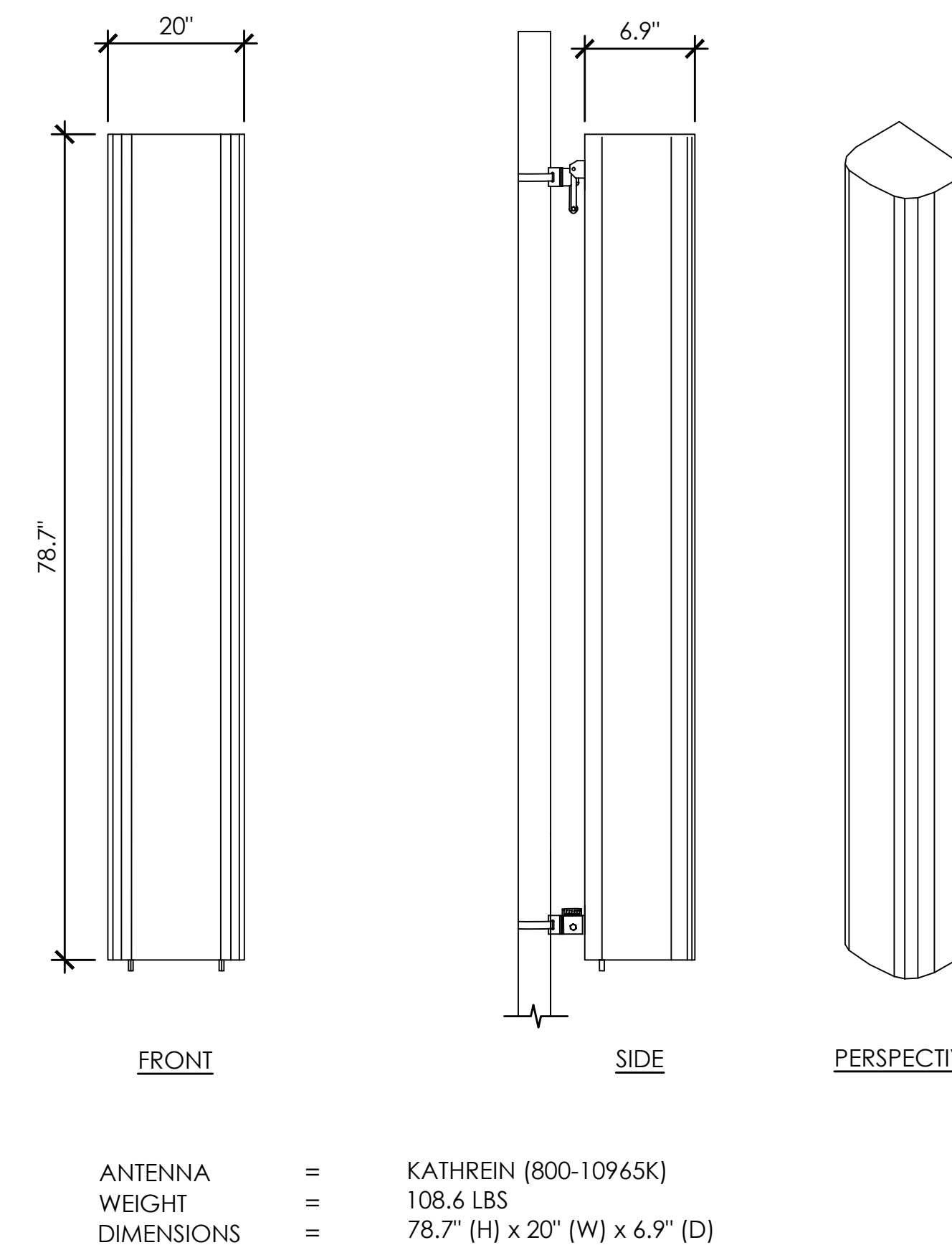

ANTENNA = KATHREIN (800-10965K)
 WEIGHT = 108.6 LBS
 DIMENSIONS = 78.7" (H) x 20" (W) x 6.9" (D)

1 PROPOSED ANTENNA SPEC

1" = 1'-0"

Issued For:
CVL00330
LOTUS ROAD
 5621 BIG SKY RANCH RD.
 PLACERVILLE, CA 95667

PREPARED FOR

 2600 Camino Ramon
 San Ramon, California 94583

Vendor:

COMPLETE
 Wireless Consulting, Inc.

AT&T SITE NO: CVL00330
 PROJECT NO: 162.2196
 DRAWN BY: MWS
 CHECKED BY: TST

REV	DATE	DESCRIPTION
1	09/11/18	100% ZD Rev 1
	06/01/18	100% ZD
	05/03/18	90% ZD

Licensee:
 IT IS A VIOLATION OF LAW FOR ANY PERSON, UNLESS THEY ARE ACTING UNDER THE DIRECTION OF A LICENSED PROFESSIONAL ENGINEER, TO ALTER THIS DOCUMENT.

Architect:

MST ARCHITECTS
 1520 River Park Drive
 Sacramento, California 95815

SHEET TITLE:
ANTENNA DETAILS

SHEET NUMBER:
A-3.2

EXHIBIT G

NOTE: MONO-BROADLEAF TO BE STRUCTURALLY ENGINEERED FOR AT LEAST 2 ADDITIONAL WIRELESS CARRIERS

NOTE: AT&T TO INSTALL "LEAF SOCKS" ON ALL PROPOSED PANEL ANTENNAS & RRH UNITS. ALL ANTENNAS & EQUIPMENT TO BE PAINTED FLAT GREEN

NOTE: BRANCHES SHOWN ARE FOR ILLUSTRATIVE PURPOSES ONLY. NOT TO SCALE

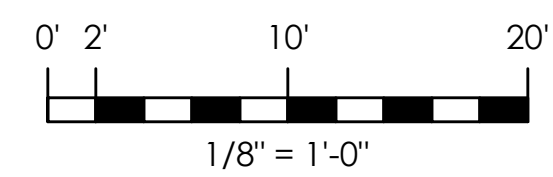
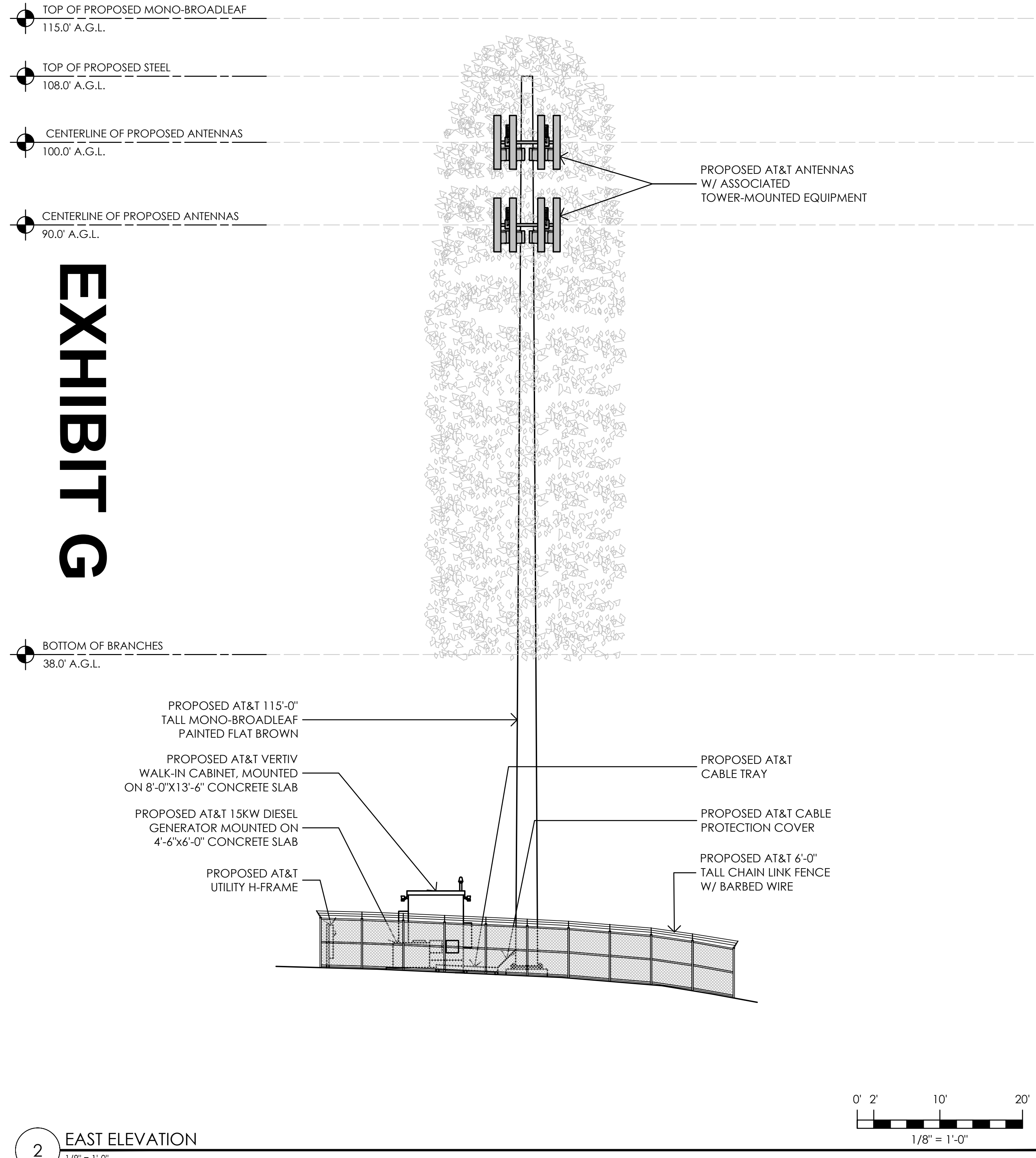

2 EAST ELEVATION
1/8" = 1'-0"

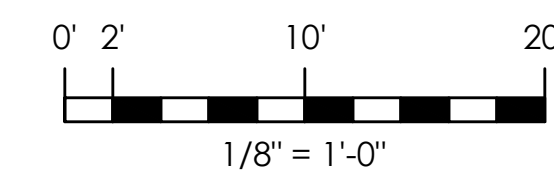
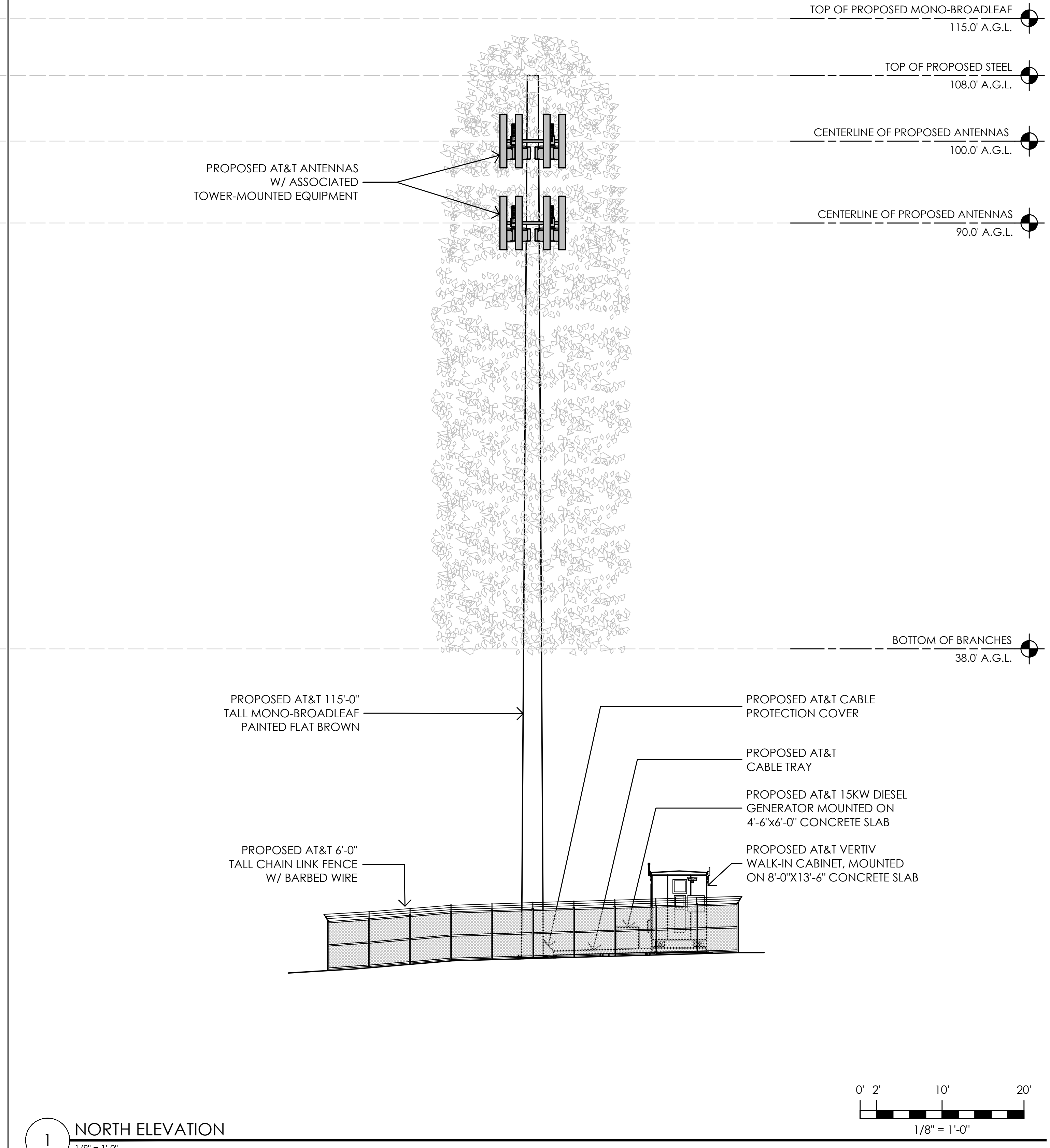

1 NORTH ELEVATION
1/8" = 1'-0"

Issued For:
CVL00330
LOTUS ROAD
5621 BIG SKY RANCH RD.
PLACERVILLE, CA 95667

PREPARED FOR
 at&t
2600 Camino Ramon
San Ramon, California 94583

Vendor:
 COMPLETE
Wireless Consulting, Inc.

AT&T SITE NO: CVL00330
PROJECT NO: 162.2196
DRAWN BY: LX
CHECKED BY: TST

REV	DATE	DESCRIPTION
1	09/11/18	100% ZD Rev 1
	06/01/18	100% ZD
	05/03/18	90% ZD

Licensee:

IT IS A VIOLATION OF LAW FOR ANY PERSON, UNLESS THEY ARE ACTING UNDER THE DIRECTION OF A LICENSED PROFESSIONAL ENGINEER, TO ALTER THIS DOCUMENT.

Architect:
 MST ARCHITECTS
1520 River Park Drive
Sacramento, California 95815

SHEET TITLE:
PROPOSED ELEVATIONS

SHEET NUMBER:
A-4.1

EXHIBIT G

NOTE: MONO-BROADLEAF TO BE STRUCTURALLY ENGINEERED FOR AT LEAST 2 ADDITIONAL WIRELESS CARRIERS

NOTE: AT&T TO INSTALL "LEAF SOCKS" ON ALL PROPOSED PANEL ANTENNAS & RRH UNITS. ALL ANTENNAS & EQUIPMENT TO BE PAINTED FLAT GREEN

NOTE: BRANCHES SHOWN ARE FOR ILLUSTRATIVE PURPOSES ONLY. NOT TO SCALE

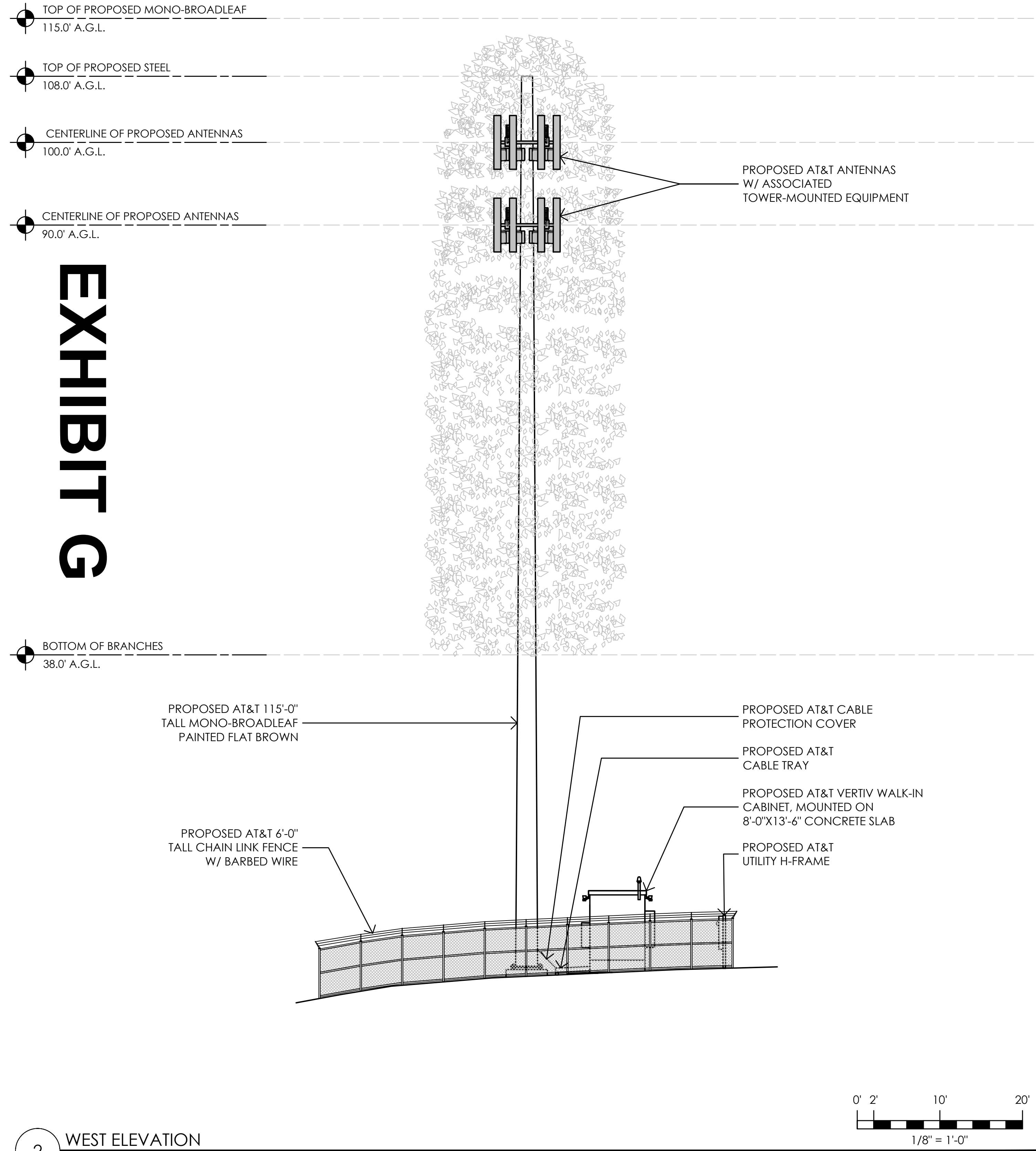

2 WEST ELEVATION
1/8" = 1'-0"

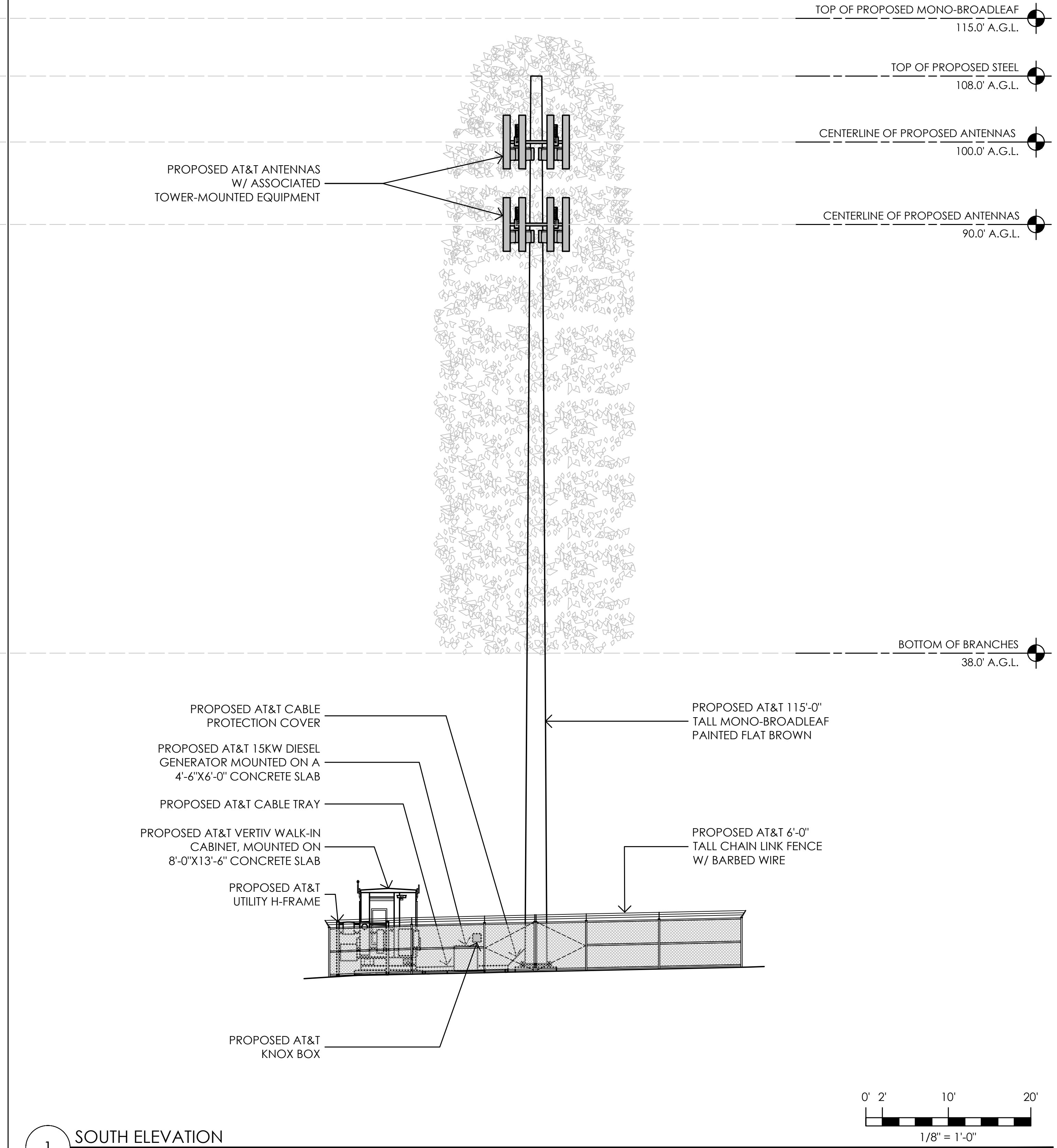

1 SOUTH ELEVATION
1/8" = 1'-0"

Issued For:

CVL00330
LOTUS ROAD

5621 BIG SKY RANCH RD.
PLACERVILLE, CA 95667

PREPARED FOR



2600 Camino Ramon
San Ramon, California 94583

Vendor:



COMPLETE
Wireless Consulting, Inc.

AT&T SITE NO: CVL00330

PROJECT NO: 162.2196

DRAWN BY: LX

CHECKED BY: TST

REV	DATE	DESCRIPTION
1	09/11/18	100% ZD Rev 1
	06/01/18	100% ZD
	05/03/18	90% ZD

Licensee:

IT IS A VIOLATION OF LAW FOR ANY PERSON, UNLESS THEY ARE ACTING UNDER THE DIRECTION OF A LICENSED PROFESSIONAL ENGINEER, TO ALTER THIS DOCUMENT.

Architect:



MST ARCHITECTS
1520 River Park Drive
Sacramento, California 95815

SHEET TITLE:

PROPOSED
ELEVATIONS

SHEET NUMBER:

A-4.2

CUP18-0007 (AT&T Gold Hill/Coloma) EXHIBIT H - COVERAGE MAP

Existing Coverage

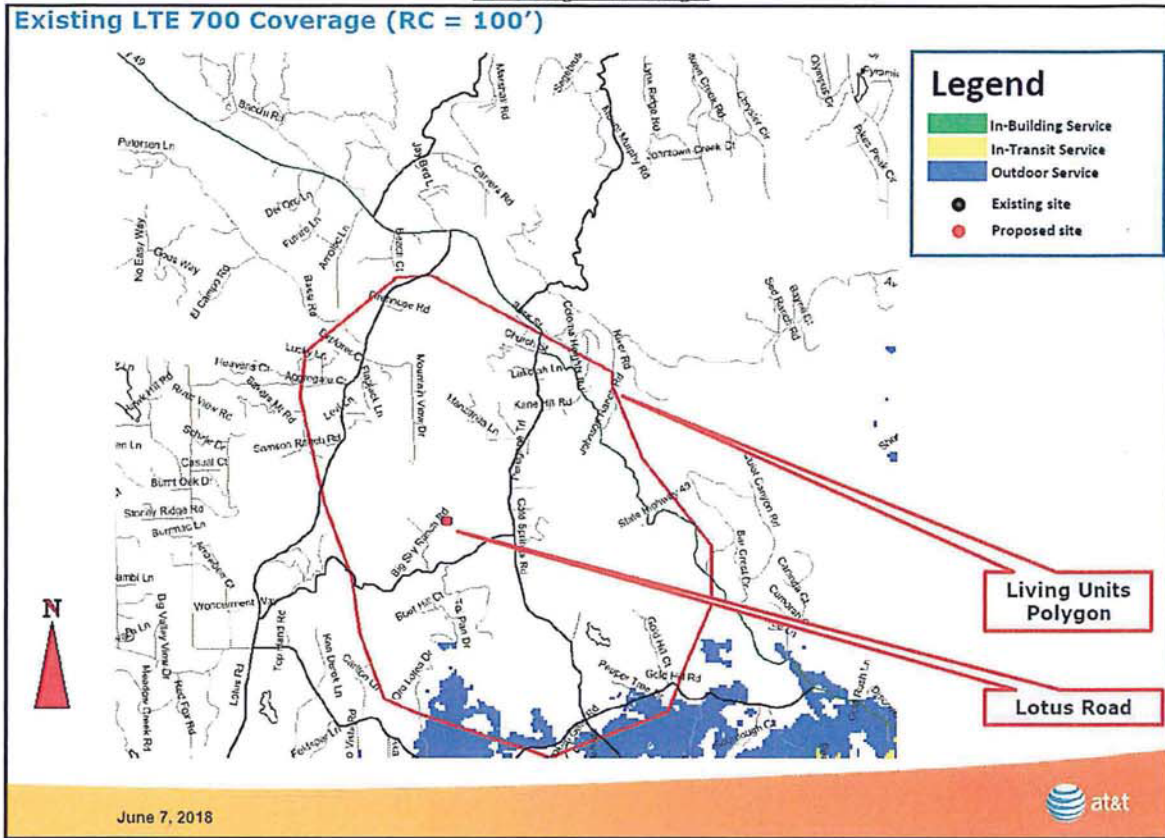

Proposed Coverage

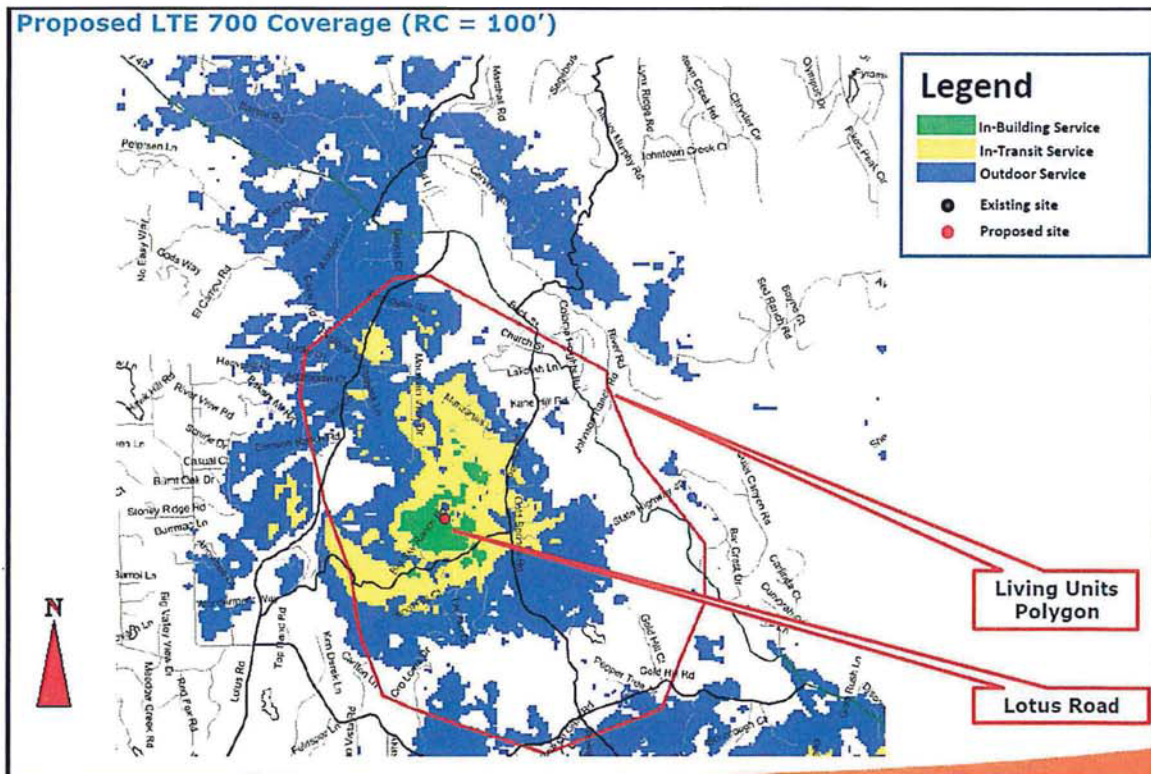

1

CUP 18-0007 (AT&T Gold Hill/Coloma) EXHIBIT I - VISUAL SIMULATIONS

Stationary drone for exact height and placement



Existing

Photosimulation of the view looking southeast from Cold Springs Road at Vineyard Lane.

Lotus Road

5621 Big Sky Ranch Rd
Placerville, CA 95667
CVL00330



Proposed broadleaf tree pole



Proposed

19-0808 D 18 of 41

2

CUP 18-0007 (AT&T Gold Hill/Coloma) EXHIBIT I - VISUAL SIMULATIONS

Stationary drone for exact height and placement



Existing

Photosimulation of the view looking northwest from the nearest point along Thompson Hill Road.

Lotus Road

5621 Big Sky Ranch Rd
Placerville, CA 95667
CVL00330



Proposed broadleaf tree pole



Proposed

19-0808 D 19 of 41

3

CUP 18-0007 (AT&T Gold Hill/Coloma) EXHIBIT I - VISUAL SIMULATIONS

Stationary drone for exact height and placement



Existing

Photosimulation of the view looking northeast from the clearest view along Thompson Hill Road.

Lotus Road

5621 Big Sky Ranch Rd
Placerville, CA 95667
CVL00330



Proposed broadleaf tree pole



Proposed

19-0808 D 20 of 41

CUP 18-0007 (AT&T Gold Hill/Coloma) EXHIBIT I - VISUAL SIMULATIONS

Aerial photograph showing the viewpoints for the photosimulations.

Lotus Road
5621 Big Sky Ranch Rd
Placerville, CA 95667
CVL00330

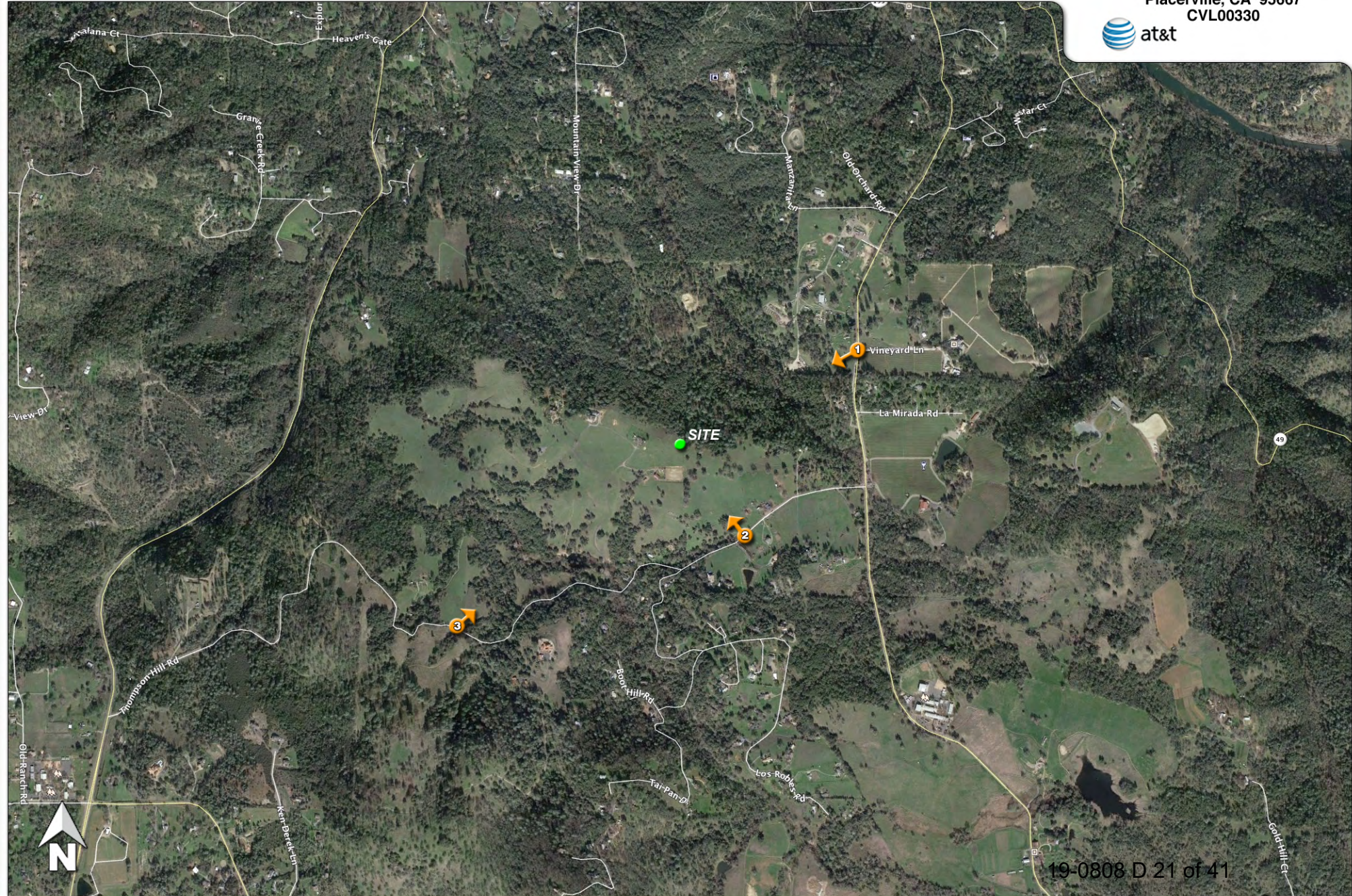

**ALTERNATIVE SITES ANALYSIS
AT&T MOBILITY**

2018 OCT 16 AM 10:57
RECEIVED
PLANNING DEPARTMENT

Site Name: CVL0330 Lotus Road
Location: 5621 Big Sky Ranch Road, Placerville, CA 95667
APN: 089-010-751

Introduction

AT&T Mobility strives to minimize visual and noise impacts for each facility and seeks to incorporate ways to preserve the local community character to the greatest extent feasible at all stages of site selection and design process. Part of this involves seeking properties in areas with substandard wireless coverage that provide the ability to meet community needs, zoning standards, and engineering requirements.

In identifying the location of a new wireless telecommunication facility to fulfill the above referenced service objectives a variety of factors are evaluated. These factors include:

- A willing landlord;
- Compliance with local zoning requirements;
- Satisfaction of the radiofrequency coverage need; and
- Constructability, including available utilities and road access.

Colocation Opportunities Investigated

The first step is always to seek existing structures that would allow for colocation instead of needing to construct a brand-new facility.

Approximately 1.1 miles away from the proposed facility, there is a 55 ft. tall slimline pole, owned by SBA Towers, located at 1242 Oro Loma Road. This facility is located up on a hill and located next to an existing residence. Furthermore, the tower itself is not fenced or enclosed in anyway. The addition of AT&T equipment would require the addition of land for it required ground equipment.

Furthermore, though existing trees provide some screening for the 55-ft. tall SBA Tower, the required height by AT&T's radio frequency engineer at this location entails doubling the height of the facility and providing a larger visual impact than at the original proposed location at 5621 Big Sky Ranch Road, Placerville, CA 95667.

Lastly, due to the terrain of AT&T's targeted search area and its objectives in reaching the southern portions of Coloma, the proposed facility must be approximately 120 ft. tall and placed closer to the hills of Marshall Gold Discovery State Historic Park.

Due to the limitations of space, lack of required height, visual impact, and inability to cover southern Coloma, the SBA Tower was eliminated as a possible colocation opportunity.

Photo of Existing SBA Ground Equipment



Existing 55-ft. Tall SBA Tower

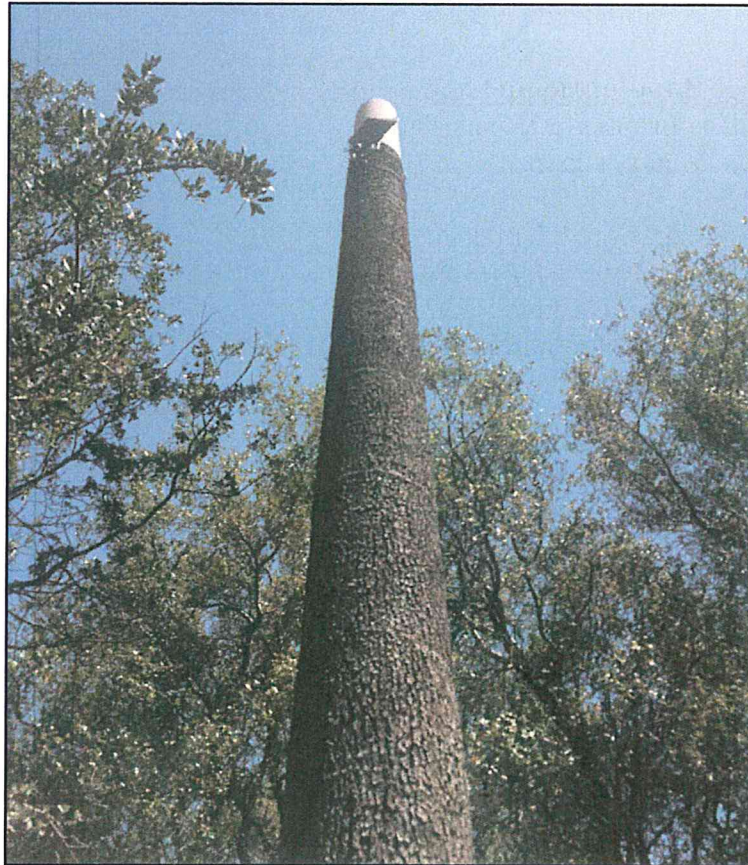

Additional Sites Investigated

Willing landlords in the search area were scarce. Additionally, due to the prevalence of private roads—the majority of the search area is bounded by Lotus Road, Cold Springs Road, and Gold Hill Road—legal access routes are difficult to obtain. Although one interested landlord may have been identified, the subsequent access easement negotiations consistently failed due to an unresponsive or unwilling property owner along the route.

Name: Toney
Address: 1820 Pet Rock Road, Placerville, CA 95667
APN: 317-030-12-100
Coordinates: 38.750959, -120.904475
Zone: RA20
Parcel Size: 24.32 acres

Alternative Site (Toney) Map

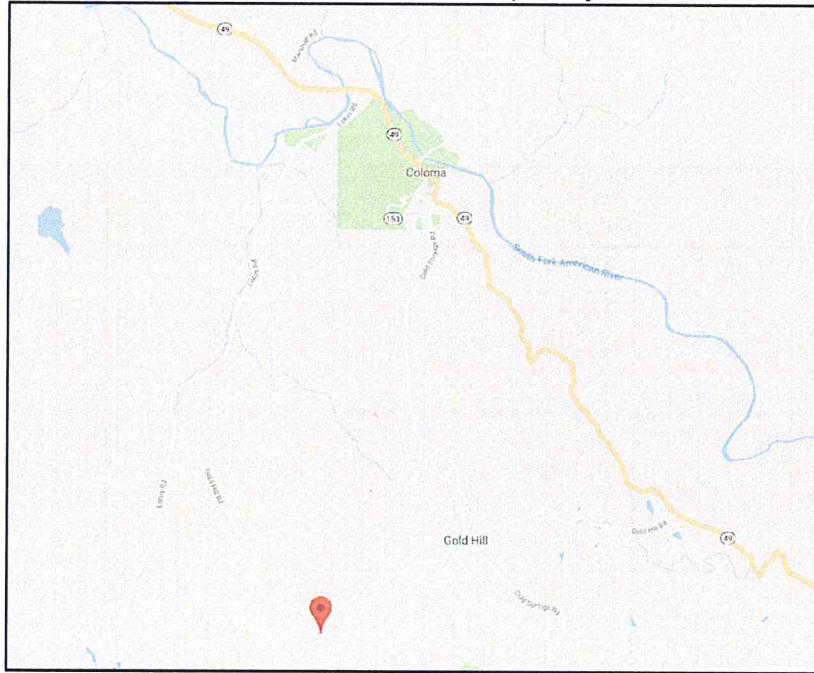

This property was a large hilltop parcel with no residences in the nearby vicinity. Though the property owner was interested, no access agreement could be negotiated to get to the potential facility location. Additionally, the potential location is up on a hill and completely undeveloped. This necessitates a widened access road, turnarounds and turnouts for fire compliance, and a retaining wall for the tower itself. The construction costs, which includes bringing power to the site, would require a grading plan, the addition of overhead power poles to the potential site, and more disturbance to the land than the proposed candidate at 5621 Big Sky Ranch Road, Placerville, CA 95667.

During investigation of locations in the southern half of the search area, AT&T's radio frequency engineer ultimately requested a location further north of Gold Hill Road in order to cover the southern portions of Coloma.

Name: Glenn
Address: 1320 Rancho Vista Road, Placerville, CA 95667
APN: 089-120-05-100
Coordinates: 38.756780, -120.911794
Zone: RE-5
Parcel Size: 11.00 acres

Alternative Site (Glenn) Map

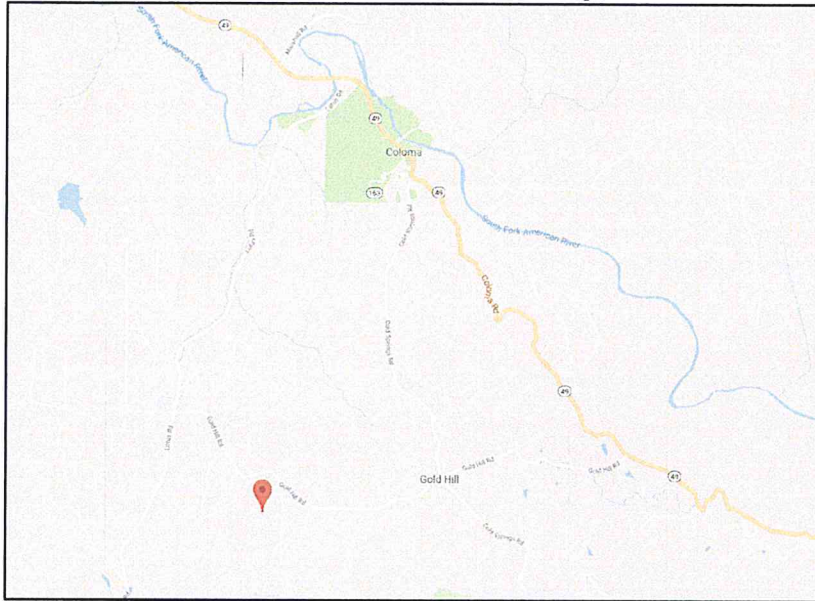

Though the property owner was interested, no access agreement could be negotiated to get to the potential facility location. Additionally, the potential location is up on a hill, which necessitates a widened access road, turnarounds and turnouts, and a retaining wall for the tower itself.

Furthermore, this potential candidate was less appealing than the Toney parcel above because of the proximity to existing residences along Rancho Vista Lane.

During investigation of locations in the southern half of the search area, AT&T's radio frequency engineer ultimately requested a location further north of Gold Hill Road in order to cover the southern portions of Coloma.

Name: David Girard Vineyards
Address: 741 Cold Springs Road, Placerville, Ca 95667
APN: 089-030-23-100
Coordinates: 38.778492, -120.890131
Zone: RE-10
Parcel Size: 41.52 acres

Alternative Site (Girard) Map

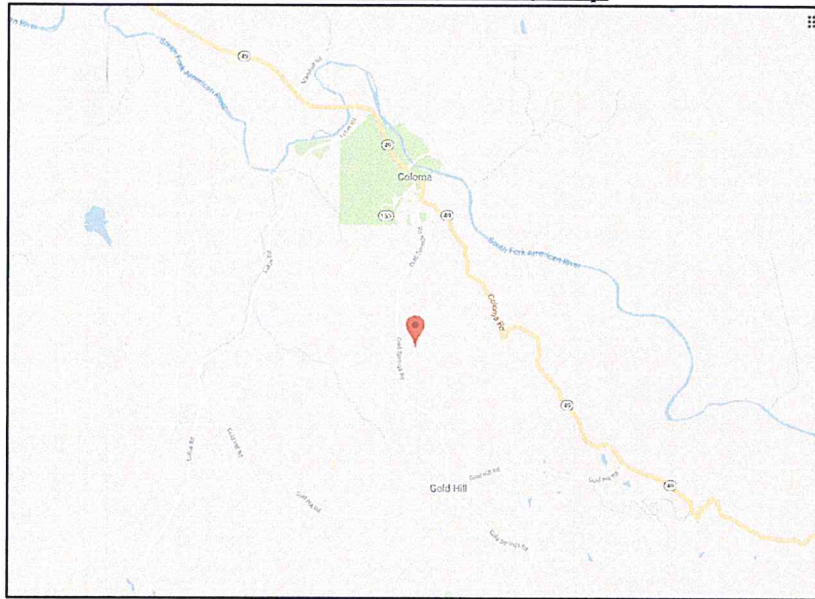

This potential candidate was promising due to the commercial use of the parcel; however, the majority of the parcel sits within a basin/valley that would require additional height added to the AT&T radio frequency engineer's originally requested 120 ft. Furthermore, AT&T investigated the office building and parking lot of the Vineyards. However, there was not enough space to site a new freestanding facility without the removal of at least two (2) parking spaces. Lastly, all active vineyard locations were eliminated due to the loss of farmable land and access road improvements needed.

Conclusion

After an exhaustive search for potential sites and co-location possibilities and a review of the applicable zoning laws, the proposed site at 5621 Big Sky Ranch Road, Placerville, CA 95667 (APN 089-010-751) was selected because it is the best available and least intrusive candidate to improve service to the area and to meet the wireless coverage objective in the area lacking coverage along this particular portion of El Dorado County.

Radio Frequency – Electromagnetic Energy (RF-EME) Compliance Report

Site No. CVL00330
MRSFR007437
Lotus Road
5621 Big Sky Ranch Road
Placerville, California 95667
El Dorado County
38.780738; -120.900953 NAD83
Monotree

2018 JUN 15 PM 2:40
RECEIVED
PLANNING DEPARTMENT

The proposed AT&T installation will be in compliance with FCC regulations upon proper installation of recommended signage.

EBI Project No. 6218004405
June 13, 2018



Prepared for:

AT&T Mobility, LLC
c/o Complete Wireless Consulting Inc
2009 V St
Sacramento, California 95818-1729

Prepared by:



EXHIBIT K

CUP18-0007

19-08080 270 41

TABLE OF CONTENTS

EXECUTIVE SUMMARY..... 1

1.0 FEDERAL COMMUNICATIONS COMMISSION (FCC) REQUIREMENTS 3

2.0 AT&T RF EXPOSURE POLICY REQUIREMENTS 5

3.0 WORST-CASE PREDICTIVE MODELING..... 5

4.0 RECOMMENDED SIGNAGE/COMPLIANCE PLAN 7

5.0 SUMMARY AND CONCLUSIONS..... 8

6.0 LIMITATIONS 8

APPENDICES

- Appendix A Personnel Certifications**
- Appendix B Compliance/Signage Plan**

EXECUTIVE SUMMARY

Purpose of Report

EnviroBusiness Inc. (dba EBI Consulting) has been contracted by AT&T Mobility, LLC to conduct radio frequency electromagnetic (RF-EME) modeling for AT&T Site CVL00330 located at 5621 Big Sky Ranch Road in Placerville, California to determine RF-EME exposure levels from proposed AT&T wireless communications equipment at this site. As described in greater detail in Section 1.0 of this report, the Federal Communications Commission (FCC) has developed Maximum Permissible Exposure (MPE) Limits for general public exposures and occupational exposures. This report summarizes the results of RF-EME modeling in relation to relevant FCC RF-EME compliance standards for limiting human exposure to RF-EME fields.

This report contains a detailed summary of the RF EME analysis for the site, including the following:

- Site Plan with antenna locations
- Graphical representation of theoretical MPE fields based on modeling
- Graphical representation of recommended signage and/or barriers

This document addresses the compliance of AT&T's transmitting facilities independently and in relation to all collocated facilities at the site.

Statement of Compliance

A site is considered out of compliance with FCC regulations if there are areas that exceed the FCC exposure limits and there are no RF hazard mitigation measures in place. Any carrier which has an installation that contributes more than 5% of the applicable MPE must participate in mitigating these RF hazards.

As presented in the sections below, based on worst-case predictive modeling, there are no modeled exposures on any accessible ground walking/working surface related to ATT's proposed antennas that exceed the FCC's occupational and/or general public exposure limits at this site.

As such, the proposed AT&T installation is in compliance with FCC regulations upon proper installation of recommended signage and/or barriers.

AT&T Recommended Signage/Compliance Plan

AT&T's RF Exposure: Responsibilities, Procedures & Guidelines document, dated October 28, 2014, requires that:

1. All sites must be analyzed for RF exposure compliance;
2. All sites must have that analysis documented; and
3. All sites must have any necessary signage and barriers installed.

Site compliance recommendations have been developed based upon protocols presented in AT&T's RF Exposure: Responsibilities, Procedures & Guidelines document, dated October 28, 2014, additional guidance provided by AT&T, EBI's understanding of FCC and OSHA requirements, and common industry practice. Barrier locations have been identified (when required) based on guidance presented in AT&T's RF Exposure: Responsibilities, Procedures & Guidelines document, dated October 28, 2014.

The following signage is recommended at this site:

- Yellow CAUTION 2B sign posted at the base of the monotree climbing ladder.

The signage proposed for installation at this site complies with AT&T's RF Exposure: Responsibilities, Procedures & Guidelines document and therefore complies with FCC and OSHA requirements. Barriers are not recommended on this site. More detailed information concerning site compliance recommendations is presented in Section 4.0 and Appendix B of this report.

1.0 FEDERAL COMMUNICATIONS COMMISSION (FCC) REQUIREMENTS

The FCC has established Maximum Permissible Exposure (MPE) limits for human exposure to Radiofrequency Electromagnetic (RF-EME) energy fields, based on exposure limits recommended by the National Council on Radiation Protection and Measurements (NCRP) and, over a wide range of frequencies, the exposure limits developed by the Institute of Electrical and Electronics Engineers, Inc. (IEEE) and adopted by the American National Standards Institute (ANSI) to replace the 1982 ANSI guidelines. Limits for localized absorption are based on recommendations of both ANSI/IEEE and NCRP.

The FCC guidelines incorporate two separate tiers of exposure limits that are based upon occupational/controlled exposure limits (for workers) and general public/uncontrolled exposure limits for members of the general public.

Occupational/controlled exposure limits apply to situations in which persons are exposed as a consequence of their employment and in which those persons who are exposed have been made fully aware of the potential for exposure and can exercise control over their exposure. Occupational/controlled exposure limits also apply where exposure is of a transient nature as a result of incidental passage through a location where exposure levels may be above general public/uncontrolled limits (see below), as long as the exposed person has been made fully aware of the potential for exposure and can exercise control over his or her exposure by leaving the area or by some other appropriate means.

General public/uncontrolled exposure limits apply to situations in which the general public may be exposed or in which persons who are exposed as a consequence of their employment may not be made fully aware of the potential for exposure or cannot exercise control over their exposure. Therefore, members of the general public would always be considered under this category when exposure is not employment-related, for example, in the case of a telecommunications tower that exposes persons in a nearby residential area.

Table I and Figure I (below), which are included within the FCC's OET Bulletin 65, summarize the MPE limits for RF emissions. These limits are designed to provide a substantial margin of safety. They vary by frequency to take into account the different types of equipment that may be in operation at a particular facility and are "time-averaged" limits to reflect different durations resulting from controlled and uncontrolled exposures.

The FCC's MPEs are measured in terms of power (mW) over a unit surface area (cm²). Known as the power density, the FCC has established an occupational MPE of 5 milliwatts per square centimeter (mW/cm²) and an uncontrolled MPE of 1 mW/cm² for equipment operating in the 1900 MHz frequency range. For the AT&T equipment operating at 850 MHz, the FCC's occupational MPE is 2.83 mW/cm² and an uncontrolled MPE of 0.57 mW/cm². For the AT&T equipment operating at 700 MHz, the FCC's occupational MPE is 2.33 mW/cm² and an uncontrolled MPE of 0.47 mW/cm². These limits are considered protective of these populations.

Table I: Limits for Maximum Permissible Exposure (MPE)				
(A) Limits for Occupational/Controlled Exposure				
Frequency Range (MHz)	Electric Field Strength (E) (V/m)	Magnetic Field Strength (H) (A/m)	Power Density (S) (mW/cm ²)	Averaging Time [E] ² , [H] ² , or S (minutes)
0.3-3.0	614	1.63	(100)*	6
3.0-30	1842/f	4.89/f	(900/f ²)*	6
30-300	61.4	0.163	1.0	6
300-1,500	--	--	f/300	6

Table 1: Limits for Maximum Permissible Exposure (MPE)				
(A) Limits for Occupational/Controlled Exposure				
Frequency Range (MHz)	Electric Field Strength (E) (V/m)	Magnetic Field Strength (H) (A/m)	Power Density (S) (mW/cm ²)	Averaging Time [E] ² , [H] ² , or S (minutes)
1,500-100,000	--	--	5	6
(B) Limits for General Public/Uncontrolled Exposure				
Frequency Range (MHz)	Electric Field Strength (E) (V/m)	Magnetic Field Strength (H) (A/m)	Power Density (S) (mW/cm ²)	Averaging Time [E] ² , [H] ² , or S (minutes)
0.3-1.34	614	1.63	(100)*	30
1.34-30	824/f	2.19/f	(180/f ²)*	30
30-300	27.5	0.073	0.2	30
300-1,500	--	--	f/1,500	30
1,500-100,000	--	--	1.0	30

f = Frequency in (MHz)
 * Plane-wave equivalent power density

Figure 1. FCC Limits for Maximum Permissible Exposure (MPE)
 Plane-wave Equivalent Power Density

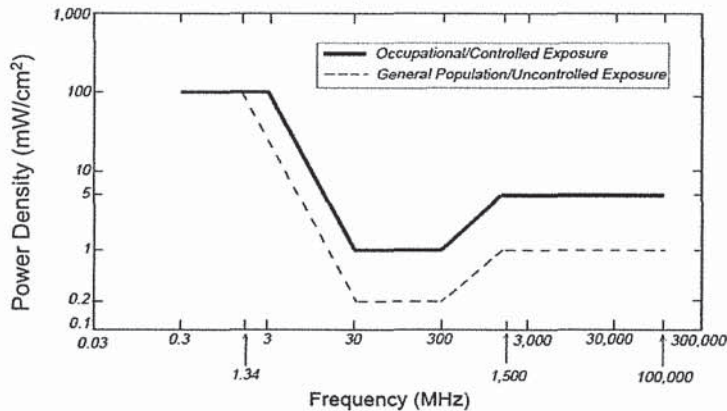

Based on the above, the most restrictive thresholds for exposures of unlimited duration to RF energy for several personal wireless services are summarized below:

Personal Wireless Service	Approximate Frequency	Occupational MPE	Public MPE
Personal Communication (PCS)	1,950 MHz	5.00 mW/cm ²	1.00 mW/cm ²
Cellular Telephone	870 MHz	2.90 mW/cm ²	0.58 mW/cm ²
Specialized Mobile Radio	855 MHz	2.85 mW/cm ²	0.57 mW/cm ²
Long Term Evolution (LTE)	700 MHz	2.33 mW/cm ²	0.47 mW/cm ²
Most Restrictive Freq. Range	30-300 MHz	1.00 mW/cm ²	0.20 mW/cm ²

MPE limits are designed to provide a substantial margin of safety. These limits apply for continuous exposures and are intended to provide a prudent margin of safety for all persons, regardless of age, gender, size, or health.

Personal Communication (PCS) facilities used by AT&T in this area operate within a frequency range of 700-1900 MHz. Facilities typically consist of: 1) electronic transceivers (the radios or cabinets) connected to wired telephone lines; and 2) antennas that send the wireless signals created by the transceivers to be received by individual subscriber units (PCS telephones). Transceivers are typically connected to antennas by coaxial cables.

Because of the short wavelength of PCS services, the antennas require line-of-site paths for good propagation, and are typically installed above ground level. Antennas are constructed to concentrate energy towards the horizon, with as little energy as possible scattered towards the ground or the sky. This design, combined with the low power of PCS facilities, generally results in no possibility for exposure to approach Maximum Permissible Exposure (MPE) levels, with the exception of areas directly in front of the antennas.

2.0 AT&T RF EXPOSURE POLICY REQUIREMENTS

AT&T's RF Exposure: Responsibilities, Procedures & Guidelines document, dated October 28, 2014, requires that:

1. All sites must be analyzed for RF exposure compliance;
2. All sites must have that analysis documented; and
3. All sites must have any necessary signage and barriers installed.

Pursuant to this guidance, worst-case predictive modeling was performed for the site. This modeling is described below in Section 3.0. Lastly, based on the modeling and survey data, EBI has produced a Compliance Plan for this site that outlines the recommended signage and barriers. The recommended Compliance Plan for this site is described in Section 4.0.

3.0 WORST-CASE PREDICTIVE MODELING

In accordance with AT&T's RF Exposure policy, EBI performed theoretical modeling using RoofView® software to estimate the worst-case power density at the site ground-level resulting from operation of the antennas. RoofView® is a widely-used predictive modeling program that has been developed by Richard Tell Associates to predict both near field and far field RF power density values for roof-top and tower telecommunications sites produced by vertical collinear antennas that are typically used in the cellular, PCS, paging and other communications services. The models utilize several operational specifications for different types of antennas to produce a plot of spatially-averaged power densities that can be expressed as a percentage of the applicable exposure limit.

For this report, EBI utilized antenna and power data provided by AT&T, and compared the resultant worst-case MPE levels to the FCC's occupational/controlled exposure limits outlined in OET Bulletin 65. For this report, EBI utilized antenna and power data provided by AT&T and compared the resultant worst-case MPE levels to the FCC's occupational/controlled exposure limits outlined in OET Bulletin 65. The assumptions used in the modeling are based upon information provided by AT&T and information gathered from other sources. There are no other wireless carriers with equipment installed at this site.

Based on worst-case predictive modeling, there are no modeled exposures on any accessible ground walking/working surface related to ATT's proposed antennas that exceed the FCC's occupational and/or general public exposure limits at this site.

At the nearest walking/working surfaces to the AT&T antennas, the maximum power density generated by the AT&T antennas is approximately 5.50 percent of the FCC's general public limit (1.10 percent of the FCC's occupational limit). The composite exposure level from all carriers on this site is approximately 5.50 percent of the FCC's general public limit (1.10 percent of the FCC's occupational

limit) at the nearest walking/working surface to each antenna. Based on worst-case predictive modeling, there are no areas at ground level related to the proposed AT&T antennas that exceed the FCC's occupational or general public exposure limits at this site. At ground level, the maximum power density generated by the antennas is approximately 5.50 percent of the FCC's general public limit (1.10 percent of the FCC's occupational limit).











A graphical representation of the RoofView® modeling results is presented in Appendix B. It should be noted that RoofView® is not suitable for modeling microwave dish antennas; however, these units are designed for point-to-point operations at the elevations of the installed equipment rather than ground-level coverage. Based on AT&T's RF Exposure: Responsibilities, Procedures & Guidelines document, dated October 28, 2014, microwave antennas are considered compliant if they are higher than 20 feet above any accessible walking/working surface. There are no microwaves installed at this site.

4.0 RECOMMENDED SIGNAGE/COMPLIANCE PLAN

Signs are the primary means for control of access to areas where RF exposure levels may potentially exceed the MPE. As presented in the AT&T guidance document, the signs must:

- Be posted at a conspicuous point;
- Be posted at the appropriate locations;
- Be readily visible; and
- Make the reader aware of the potential risks prior to entering the affected area.

The table below presents the signs that may be used for AT&T installations.

Informational Signs		Alerting Signs	
 <p style="text-align: center;">INFO 1</p>	 <p style="text-align: center;">NOTICE 1</p>	 <p style="text-align: center;">NOTICE 2</p>	
 <p style="text-align: center;">INFO 2</p>	 <p style="text-align: center;">NOTICE DECAL</p>		
 <p style="text-align: center;">INFO 3</p>	 <p style="text-align: center;">CAUTION 1 - ROOFTOP</p>	 <p style="text-align: center;">CAUTION 2 - ROOFTOP</p>	
 <p style="text-align: center;">CAUTION - TOWER</p>	 <p style="text-align: center;">WARNING</p>		

Based upon protocols presented in AT&T's RF Exposure: Responsibilities, Procedures & Guidelines document, dated October 28, 2014, and additional guidance provided by AT&T, the following signage is recommended on the site:

- Yellow CAUTION 2B sign posted at the base of the monotree climbing ladder.

No barriers are required for this site. Barriers should be constructed of weather-resistant plastic or wood fencing. Barriers may consist of railing, rope, chain, or weather-resistant plastic if no other types are permitted or are feasible. Painted stripes should only be used as a last resort and only in regions where there is little chance of snowfall. If painted stripes are selected as barriers, it is recommended that the stripes and signage be illuminated. The signage and any barriers are graphically represented in the Signage Plan presented in Appendix B.

5.0 SUMMARY AND CONCLUSIONS

EBI has prepared this Radiofrequency Emissions Compliance Report for the proposed AT&T telecommunications equipment at the site located at 5621 Big Sky Ranch Road in Placerville, California.

EBI has conducted theoretical modeling to estimate the worst-case power density from AT&T antennas to document potential MPE levels at this location and ensure that site control measures are adequate to meet FCC and OSHA requirements, as well as AT&T's corporate RF safety policies. As presented in the preceding sections, based on worst-case predictive modeling, there are no modeled exposures on any accessible ground walking/working surface related to ATT's proposed antennas that exceed the FCC's occupational and/or general public exposure limits at this site.

Signage is recommended at the site as presented in Section 4.0 and Appendix B. Posting of the signage brings the site into compliance with FCC rules and regulations and AT&T's corporate RF safety policies.

6.0 LIMITATIONS

This report was prepared for the use of AT&T Mobility, LLC to meet requirements outlined in AT&T's corporate RF safety guidelines. It was performed in accordance with generally accepted practices of other consultants undertaking similar studies at the same time and in the same locale under like circumstances. The conclusions provided by EBI are based solely on the information provided by the client. The observations in this report are valid on the date of the investigation. Any additional information that becomes available concerning the site should be provided to EBI so that our conclusions may be revised and modified, if necessary. This report has been prepared in accordance with Standard Conditions for Engagement and authorized proposal, both of which are integral parts of this report. No other warranty, expressed or implied, is made.

Appendix A

Personnel Certifications

Reviewed and Approved by:



sealed 14jun2018

Michael McGuire
Electrical Engineer

Note that EBI's scope of work is limited to an evaluation of the Radio Frequency – Electromagnetic Energy (RF-EME) field generated by the antennas and broadcast equipment noted in this report. The engineering and design of the structure, as well as the impact of the antennas and broadcast equipment on the structural integrity of the structure, are specifically excluded from EBI's scope of work.

EBI Consulting

Preparer Certification

I, David Keirstead, state that:

- I am an employee of EnviroBusiness Inc. (d/b/a EBI Consulting), which provides RF-EME safety and compliance services to the wireless communications industry.
- I have successfully completed RF-EME safety training, and I am aware of the potential hazards from RF-EME and would be classified "occupational" under the FCC regulations.
- I am familiar with the FCC rules and regulations as well as OSHA regulations both in general and as they apply to RF-EME exposure.
- I have been trained in on the procedures outlined in AT&T's RF Exposure: Responsibilities, Procedures & Guidelines document (dated October 28, 2014) and on RF-EME modeling using RoofView® modeling software.
- I have reviewed the data provided by the client and incorporated it into this Site Compliance Report such that the information contained in this report is true and accurate to the best of my knowledge.

David Keirstead

Appendix B

Compliance/Signage Plan

At the nearest walking/working surfaces to the AT&T antennas, the maximum power density generated by the AT&T antennas is approximately 5.50 percent of the FCC's general public limit (1.10 percent of the FCC's occupational limit). The composite exposure level from all carriers on this site is approximately 5.50 percent of the FCC's general public limit (1.10 percent of the FCC's occupational limit) at the nearest walking/working surface to each antenna. Based on worst-case predictive modeling, there are no areas at ground level related to the proposed AT&T antennas that exceed the FCC's occupational or general public exposure limits at this site. At ground level, the maximum power density generated by the AT&T antennas is approximately 5.50 percent of the FCC's general public limit (1.10 percent of the FCC's occupational limit).

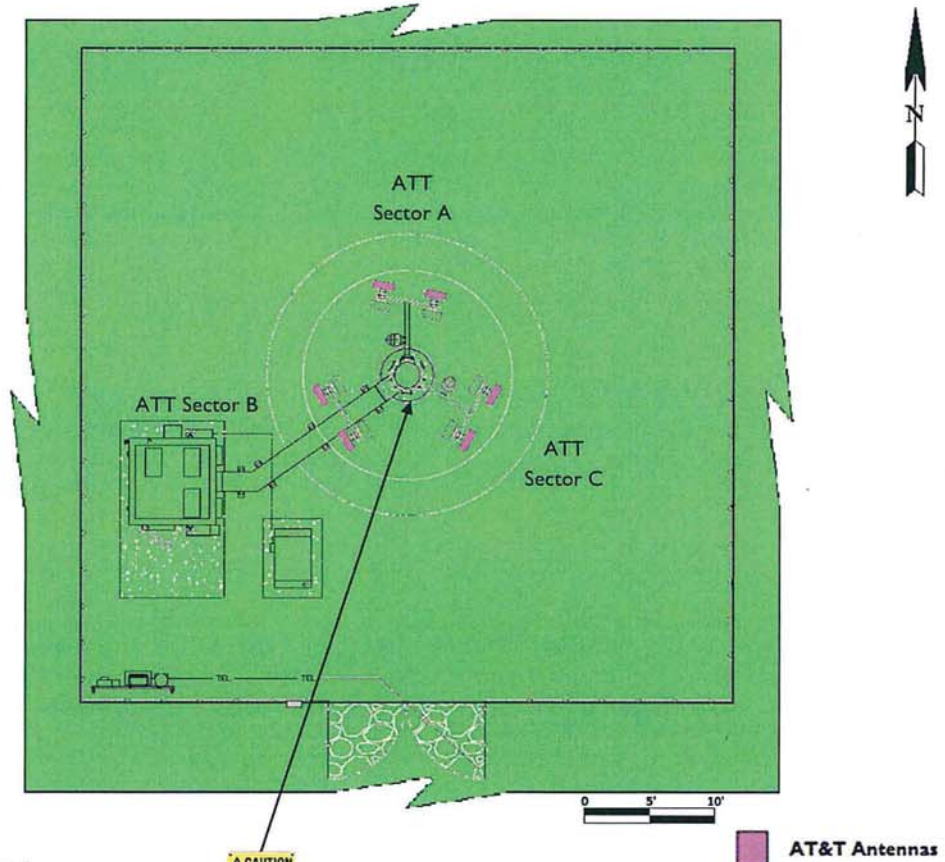

% FCC Public Exposure Limit	
■	Exposure Level \geq 5,000
■	500 < Exposure Level \leq 5,000
■	100 < Exposure Level \leq 500
■	Exposure Level \leq 100

Sign Identification Legend			
	Denotes AT&T Information Sign 1		Denotes AT&T NOTICE Sign
	Denotes AT&T Information Sign 2		Denotes AT&T CAUTION Sign
	Denotes AT&T Information Sign 3		Denotes AT&T CAUTION Tower Sign
	Denotes AT&T Information Sign 4		Denotes AT&T WARNING Sign



<p>Compliance/Signage Plan Facility Operator: AT&T Mobility Site Name: Lotus Road AT&T Site Number: CVL00330 USID Number: 203520 Report Date: 06-13-18</p>	<p>EBI Consulting Environmental Engineering & Design</p>
--	--