

---

# **Capital Improvement Program Project Updates**

## **Presentation to the Parks and Recreation Commission**

**March 3, 2026**

---



**El Dorado County  
Department of Transportation**

# Presentation Purpose

---

- Inform the Commission of the upcoming projects related to parks and recreation, bicycle and pedestrian mobility that are within DOT's Capital Improvement Program
- Answer any questions from Commission and the public
- Receive comments or feedback from the Commission moving forward with project design

# Presentation Outline

---

1. El Dorado Trail Extension - Shingle Springs
2. El Dorado Trail Extension - Halcon to Ponderado
3. Henningsen / Lotus Road Class I Trail
4. Diamond Springs Pedestrian Facility Improvements
5. Diamond Springs Parkway Phase 1B
6. Missouri Flat Road Pedestrian Overcrossing

# El Dorado Trail Extension - Shingle Springs

---

- Construct a Class I path on El Dorado Trail from Shingle Springs Drive to South Shingle Road
- \$1.4 million CMAQ grant for design and RW awarded in 2022
- Total project cost estimate = \$6.7 million
- Potential 2-phase construction due to funding limitations
- Phase 1: Shingle Springs Drive to Mother Lode Drive
- Phase 2: Mother Lode Drive to South Shingle Drive
- Environmental studies currently in progress

# El Dorado Trail Extension - Shingle Springs

## LEGEND

- - - PROPOSED CLASS I MULTI-USE TRAIL (PHASE I)
- - - PROPOSED CLASS I MULTI-USE TRAIL (PHASE II)
- X PICTURE NUMBER (SEE ATTACHMENT D)
- U.S. HIGHWAY 50
- MAJOR ROADWAY

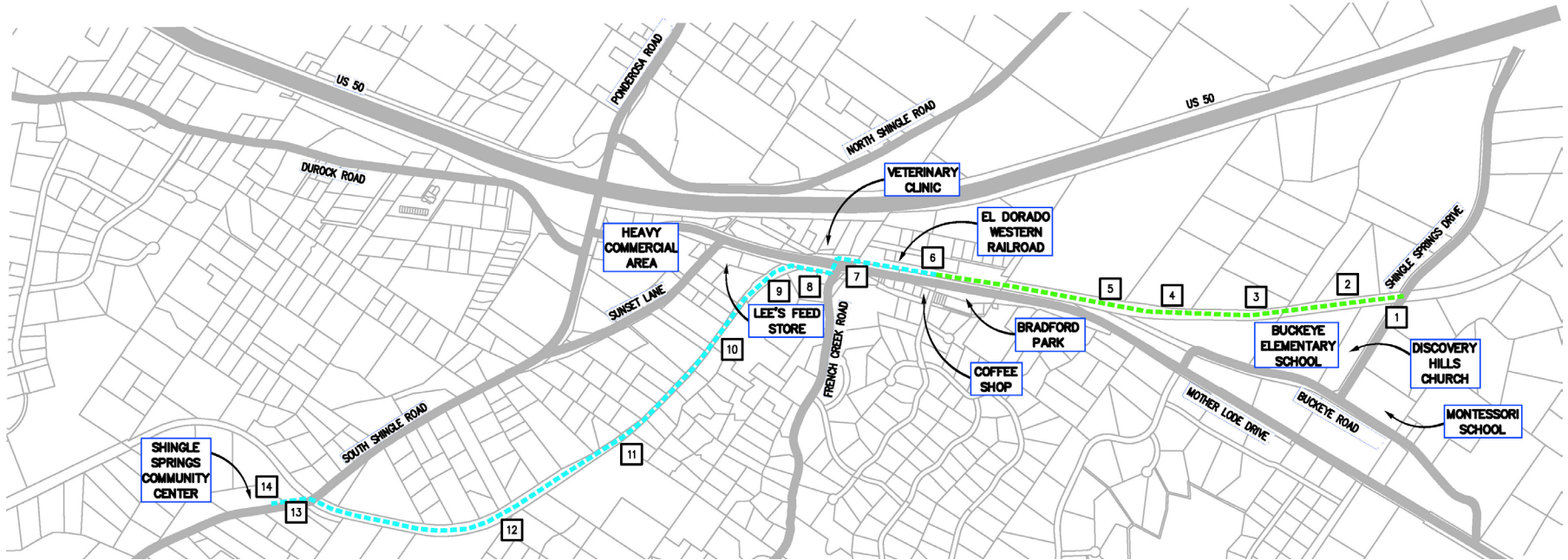

# Proposed Shingle Springs Dr Class II

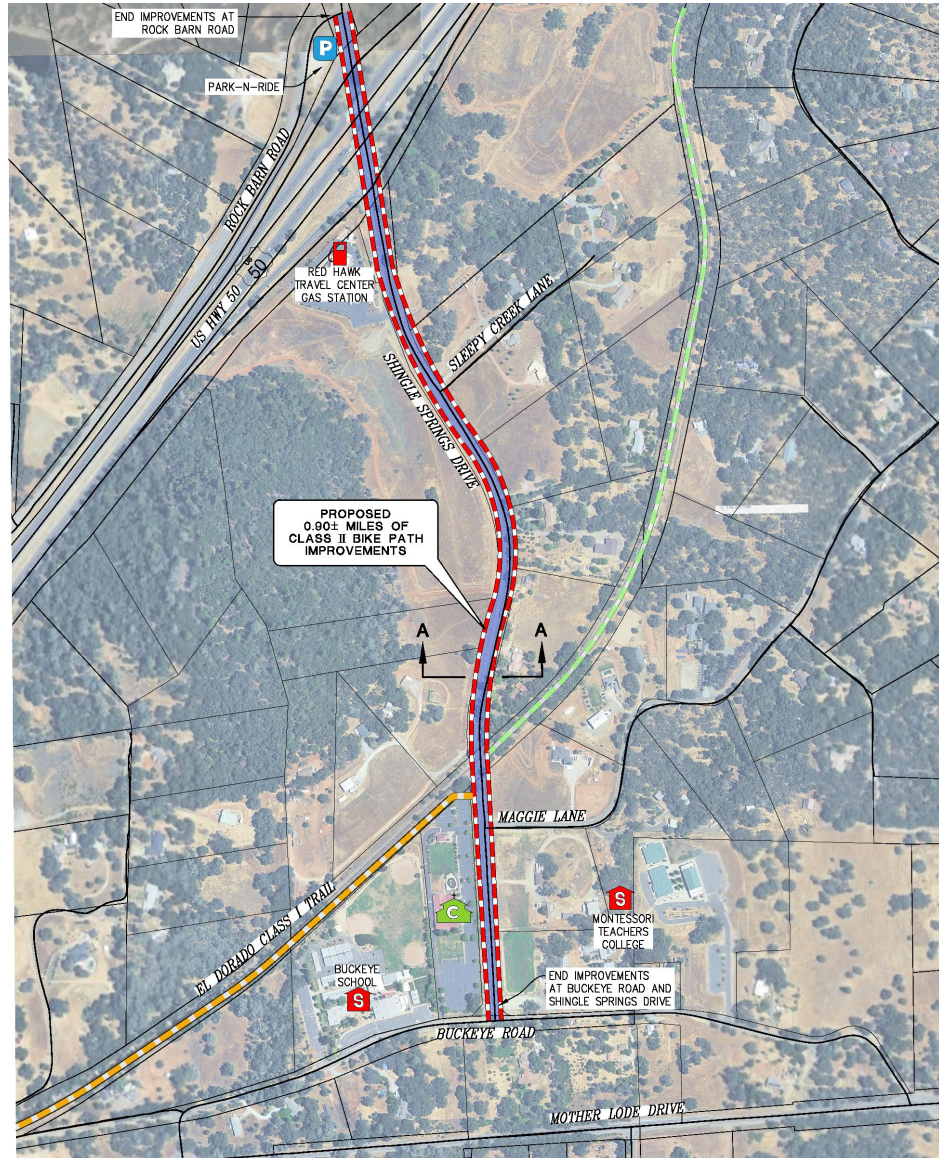

**Connectivity:  
El Dorado Trail  
Schools  
Park and Ride  
Tribal land and  
businesses**

# El Dorado Trail Extension - Halcon to Ponderado

---

## PROJECT OVERVIEW:

- Extends Class I Trail from Halcon Road (in Camino) to Ponderado Road Extension Project
- Provides future connection to cross Hwy 50
- Improve fire and property access along upper (north) area of trail

# El Dorado Trail Extension - Halcon to Pondorado

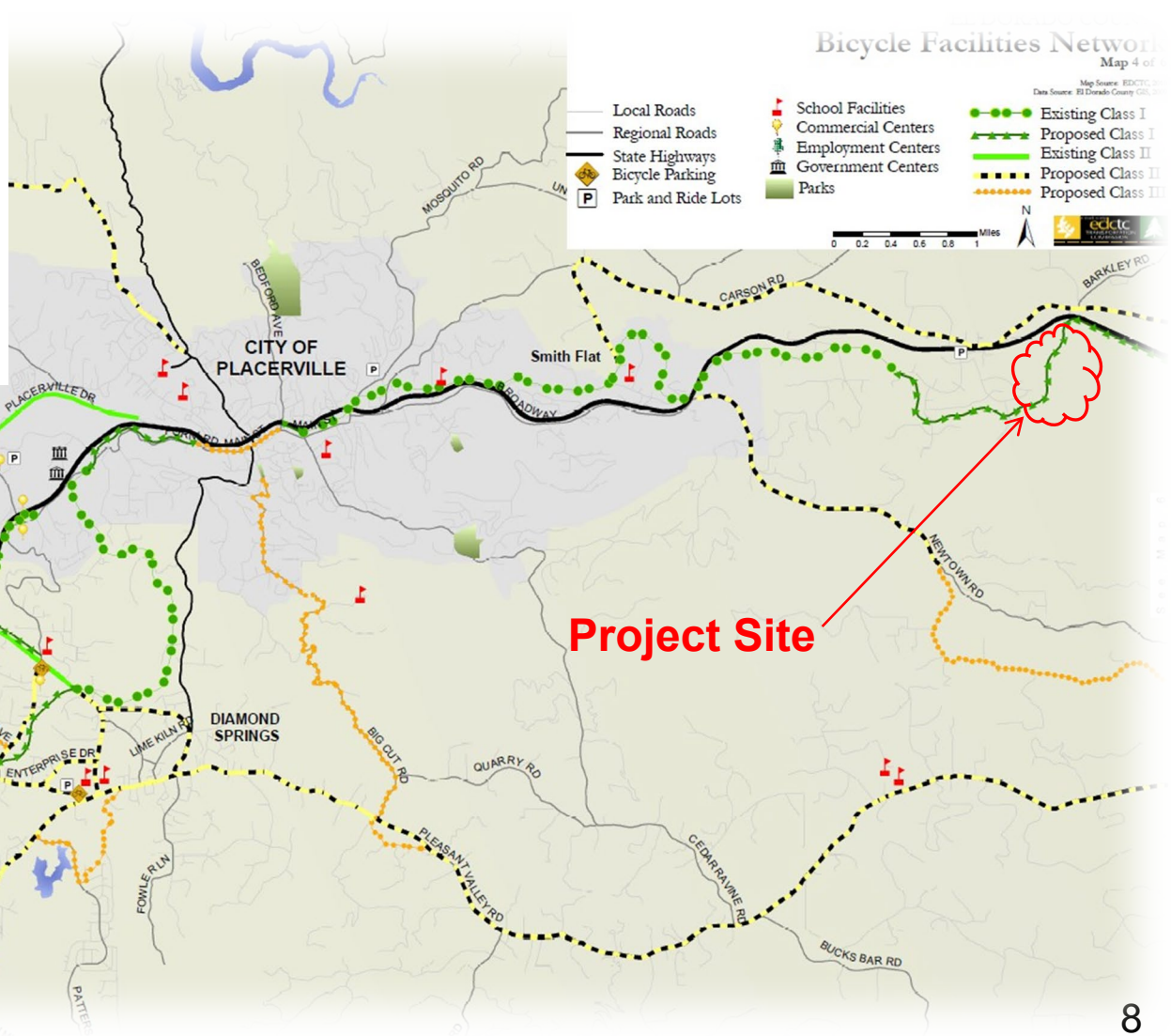
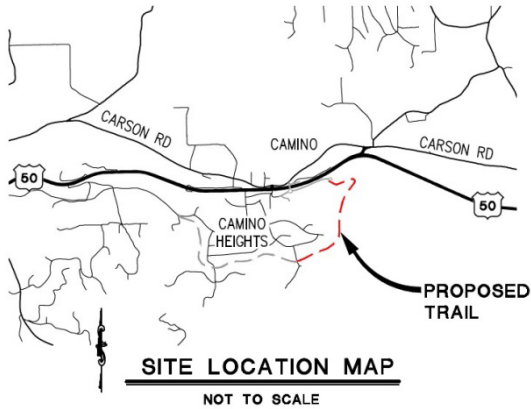

# El Dorado Trail Extension - Halcon to Ponderado

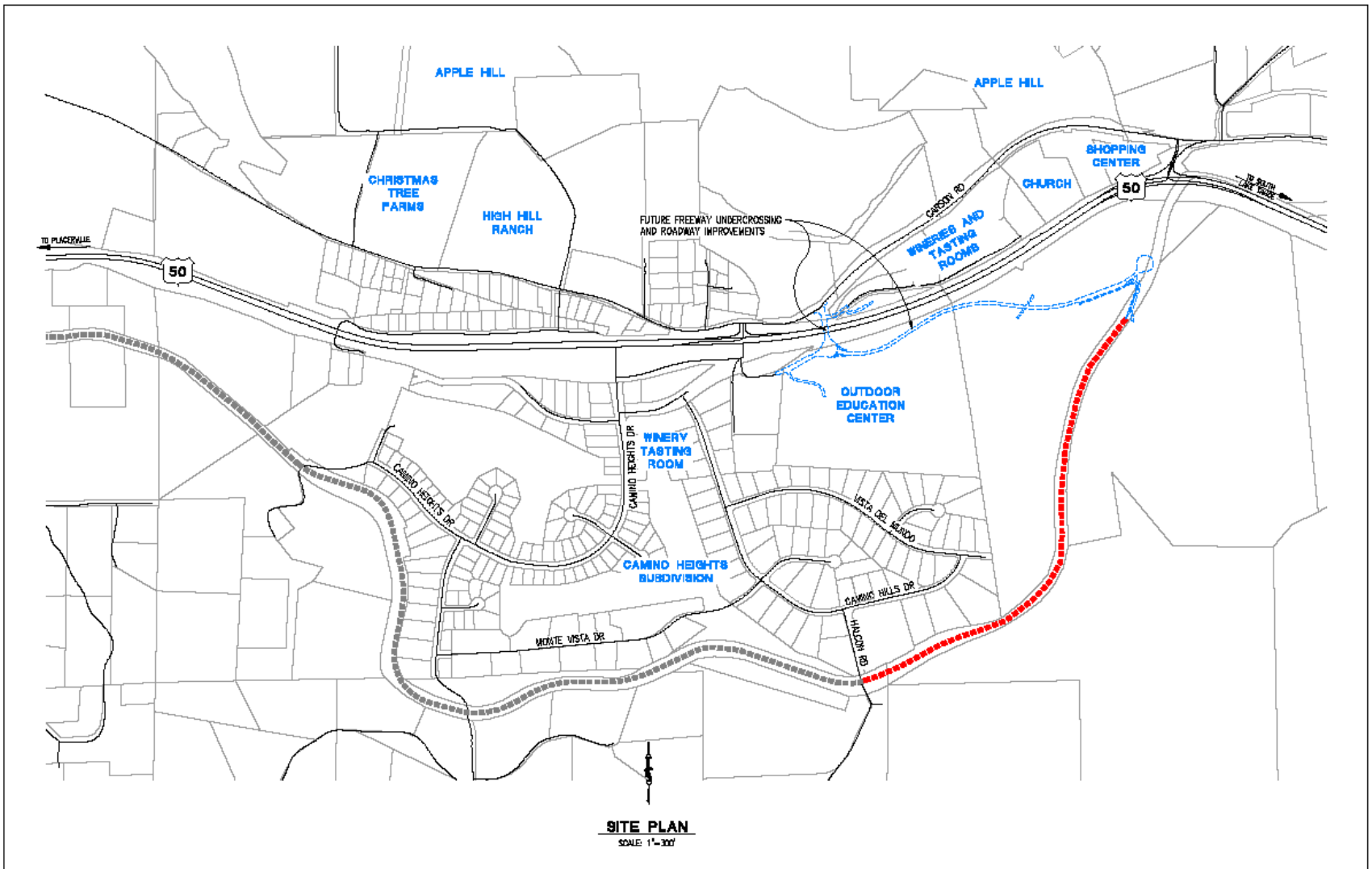

**PRELIMINARY**

# El Dorado Trail Extension - Halcon to Ponderado

---

## PROJECT LOOK AHEAD:

- Awarded CMAQ Grant (PE & ROW)
- Environmental Complete
- Construction - TBD
- County also evaluating and pursuing other funding sources

# Henningesen / Lotus Road Class I Trail

---

## PROJECT HIGHLIGHTS

- Construct approximately 2,300 feet of Class I trail improvements from Henningesen Lotus Park to State Route 49 along Lotus Road that ties into nature trails, park, sidewalks, accommodates bicycles & pedestrians (minimizes impacts)
- Includes approximately 1,000 feet of elevated boardwalk
- CMAQ grant for PE and RW
- Environmental clearance complete
- All improvements within County RW
- Potential for future Class I trail extensions



# Henningsen / Lotus Road Class I Trail

## LEGEND

- EXISTING CLASS II BIKE LANE
- EXISTING SIDEWALK
- PROPOSED CLASS 1 TRAIL

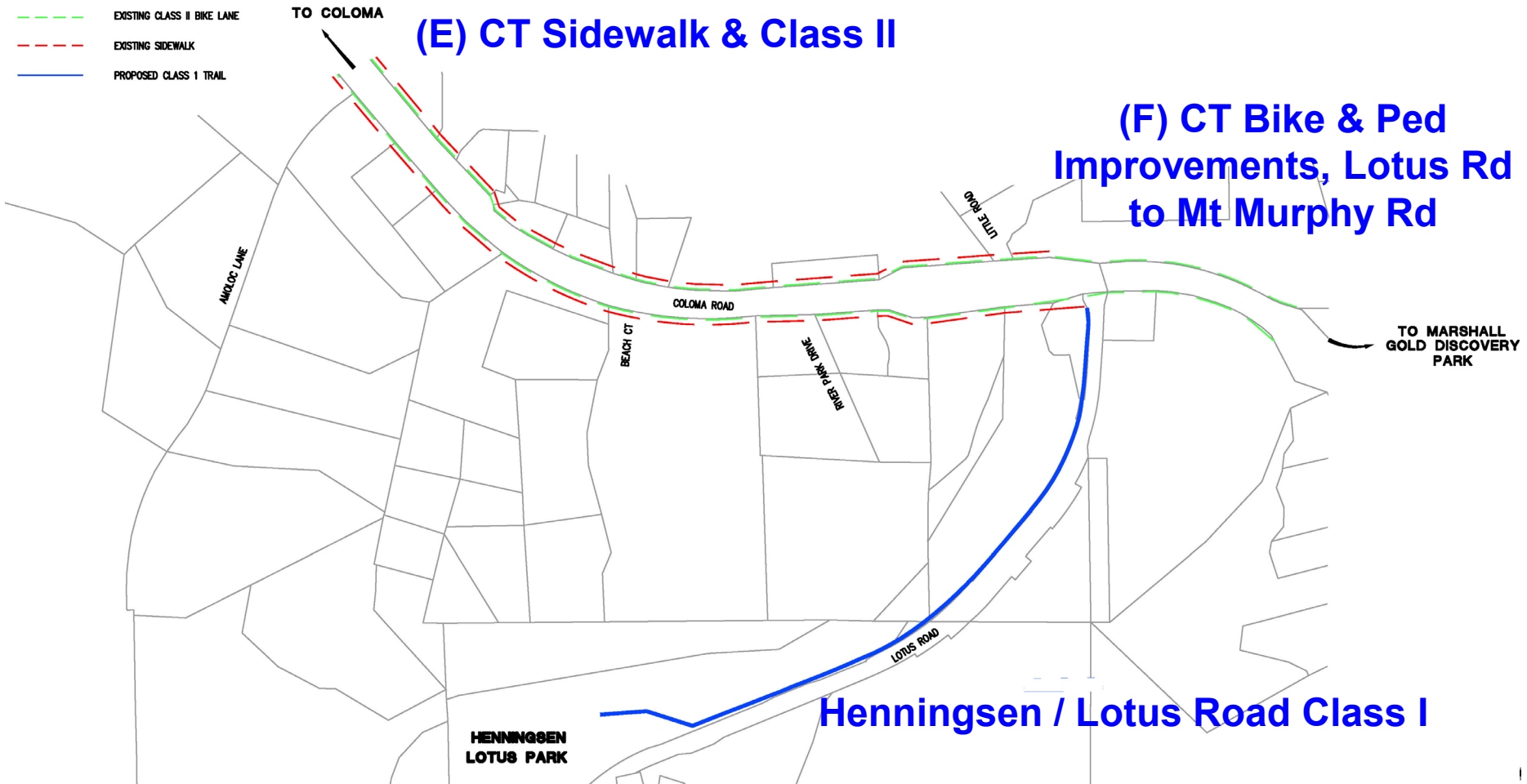

# Henningesen / Lotus Road Class I Trail

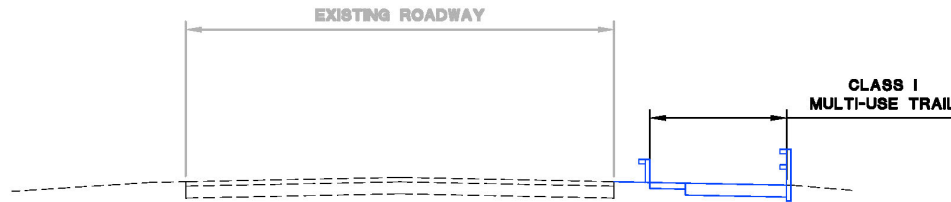

**LOTUS ROAD  
CLASS I MULTI-USE TRAIL IMPROVEMENTS**  
NOT TO SCALE

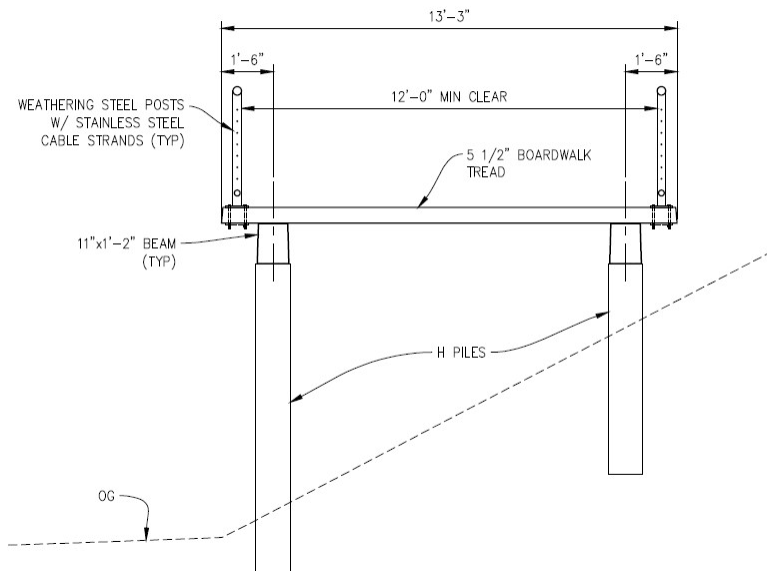

**PRELIMINARY CONCEPT**

# Diamond Springs Pedestrian Facility Improvements

---

## PROJECT HIGHLIGHTS

- Install bicycle facilities and pedestrian facilities, including sidewalks and ADA features
- CMAQ grant for PE and RW
- Environmental clearance complete
- Currently in RW Phase
- Seeking construction grant funds

# Diamond Springs Pedestrian Facility Improvements

---

Location

Map





# Diamond Springs Pedestrian Facility Improvements



**DIAMOND SPRINGS  
PEDESTRIAN FACILITY  
IMPROVEMENTS**  
CIP NO. 36109013  
DIAMOND SPRINGS,  
COUNTY OF EL DORADO  
CALIFORNIA

**LEGEND**

PROPOSED SIDEWALK  
PEDESTRIAN FACILITY  
IMPROVEMENTS PER  
CIP NO. 36109013: 

EXISTING SIDEWALK: 



**COUNTY OF EL DORADO  
DEPARTMENT OF  
TRANSPORTATION**



**FEBRUARY 12, 2020**

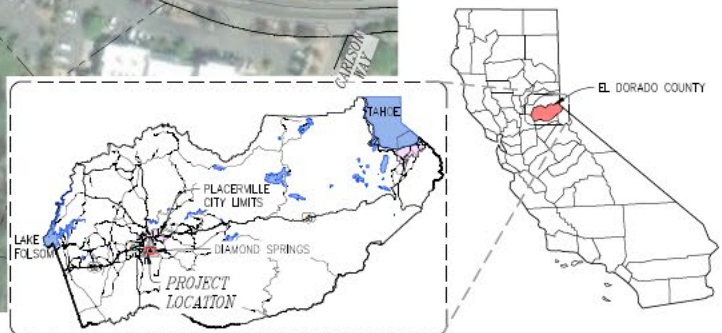

**PRELIMINARY**

Drawing Name: 26-0338 A 17 of 22 - Project: Pedestrian Facility Improvements (CIP No. 36109013) - Date: 02/12/2020 - 08:53 AM - Job No. 26-0338 A 17 of 22 - El Dorado County, California

# Diamond Springs Parkway Phase 1B

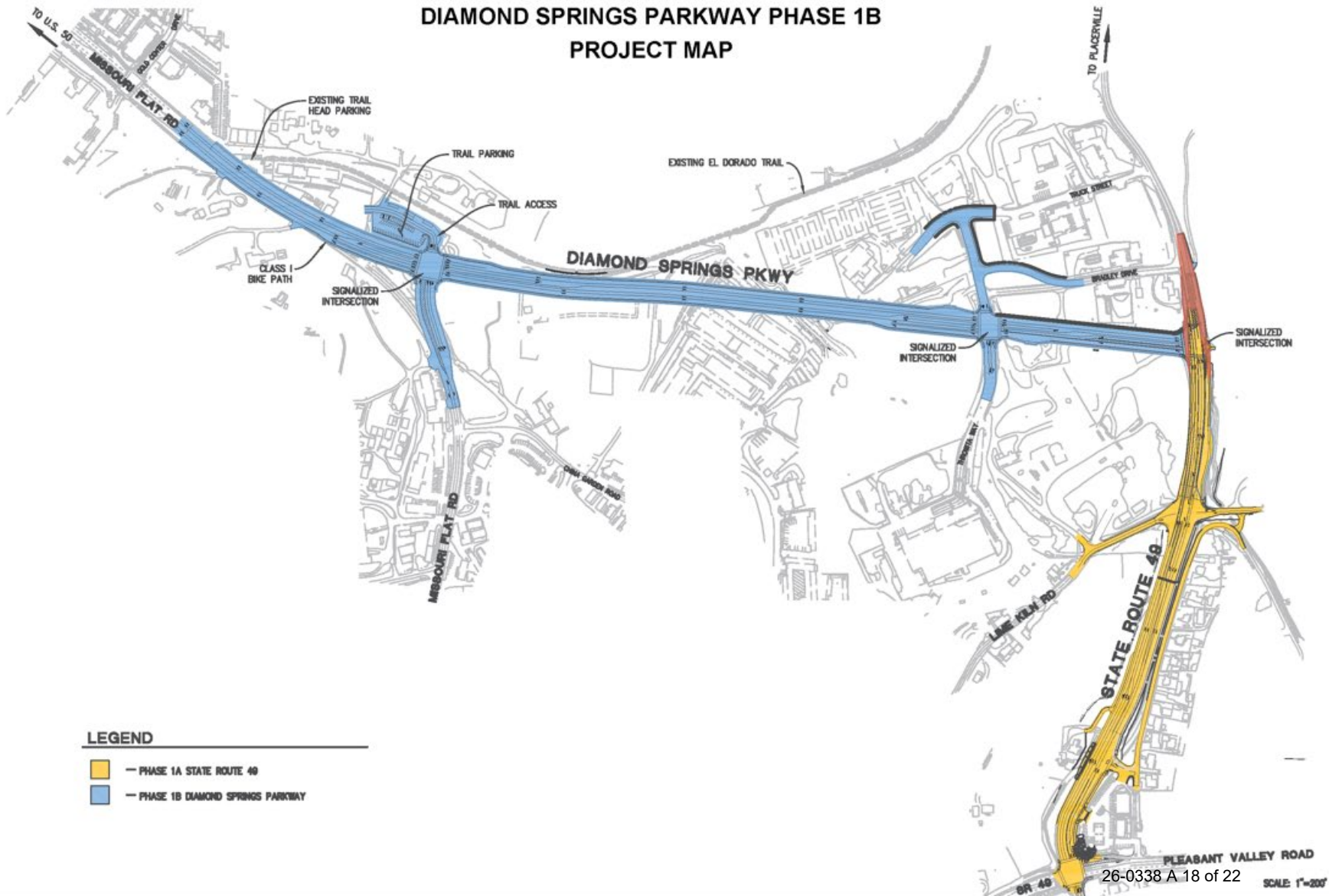

# Missouri Flat Road Pedestrian Overcrossing

---



- **2025 ASCE State of CA Outstanding Bikeways & Trails Project**
- **Design & Construction by Transportation Department**
- **Maintained by CAO Parks and Trails Division**

# Missouri Flat Road Pedestrian Overcrossing

---



# Missouri Flat Road Pedestrian Overcrossing

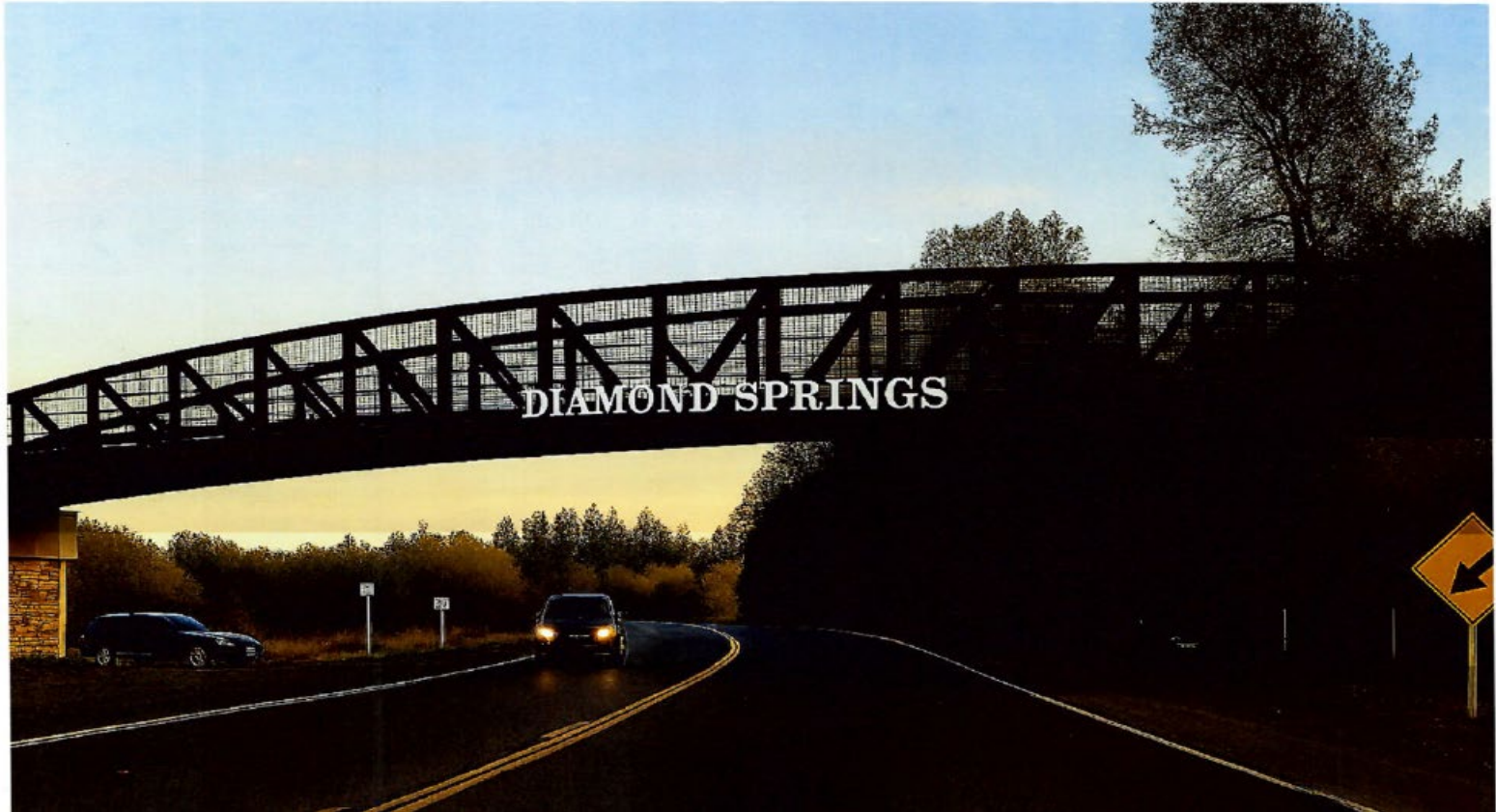

- Proposed community sign by member of public

# Questions?

---