

S17-0016/AT&T CAF4
Site 7 Gold Hill
Location Map
Exhibit A

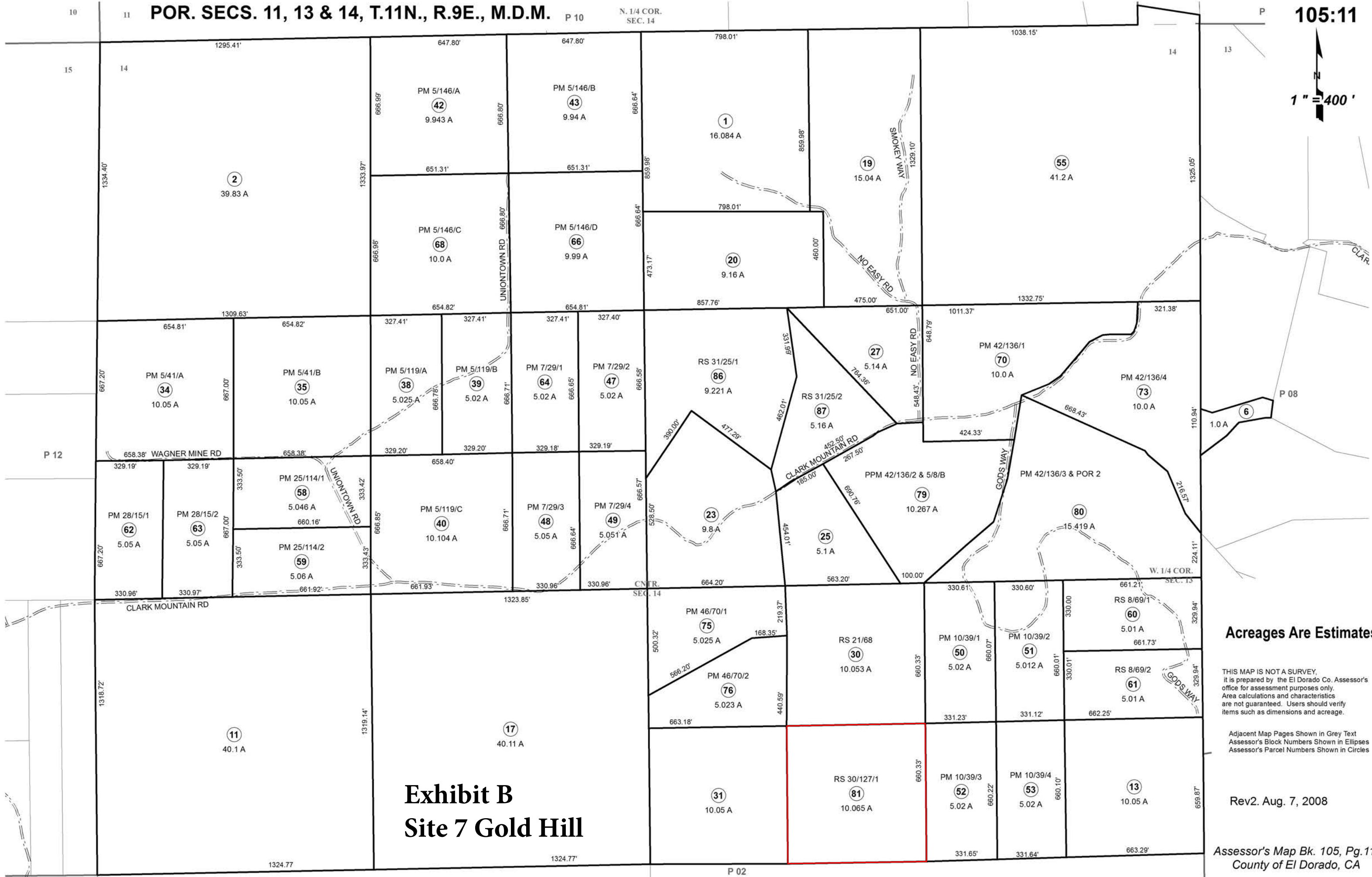

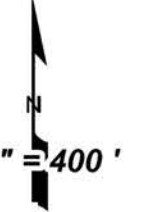

**Exhibit B
Site 7 Gold Hill**

Acreages Are Estimates

THIS MAP IS NOT A SURVEY. It is prepared by the El Dorado Co. Assessor's office for assessment purposes only. Area calculations and characteristics are not guaranteed. Users should verify items such as dimensions and acreage.

Adjacent Map Pages Shown in Grey Text
Assessor's Block Numbers Shown in Ellipses
Assessor's Parcel Numbers Shown in Circles

Rev2. Aug. 7, 2008

Assessor's Map Bk. 105, Pg. 11
County of El Dorado, CA

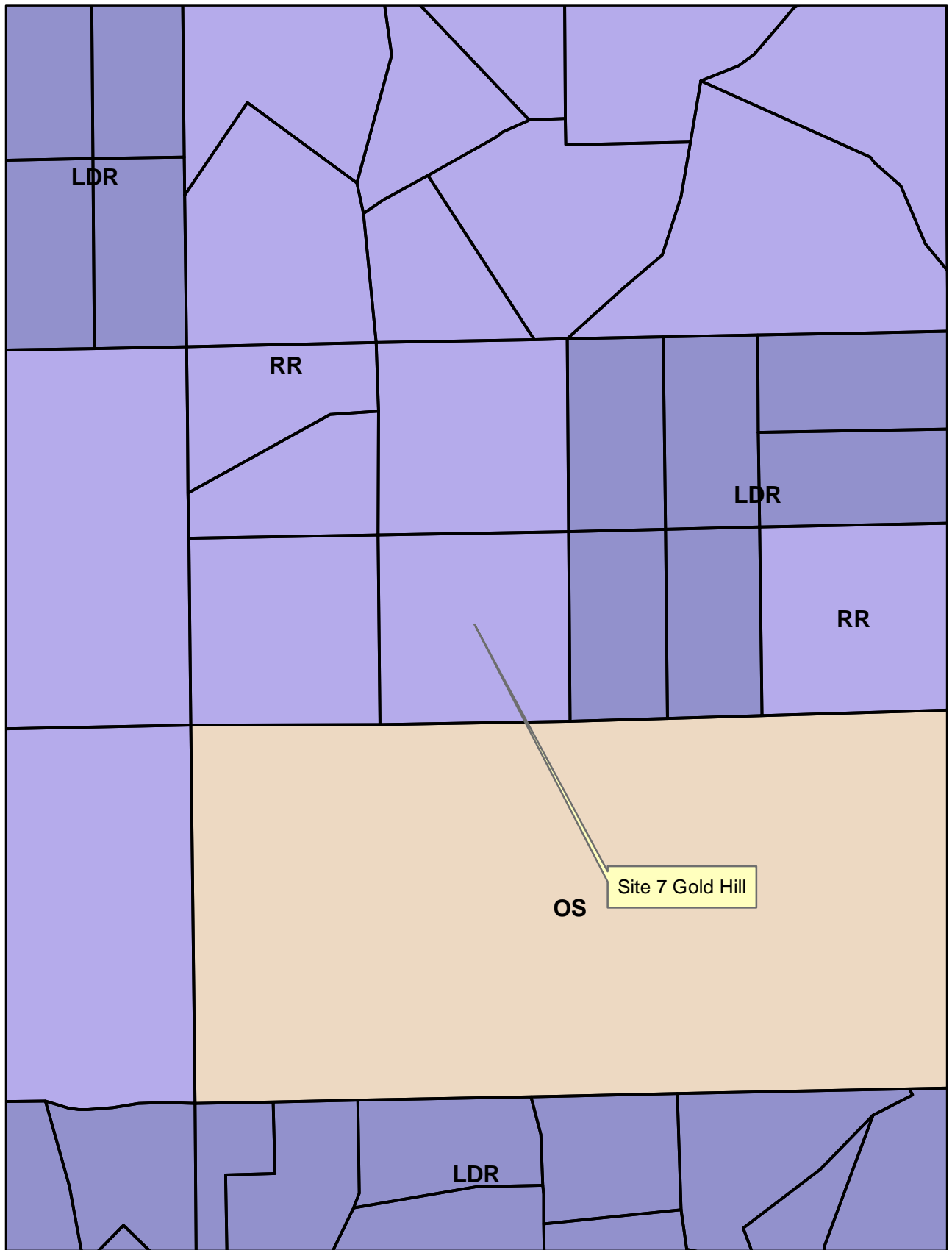

S17-0016/AT&T CAF4
 Site 7 Gold Hill
 General Plan Map
 Exhibit C



- LDR
- OS
- RR

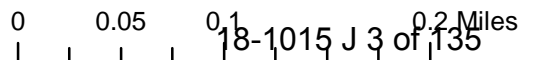

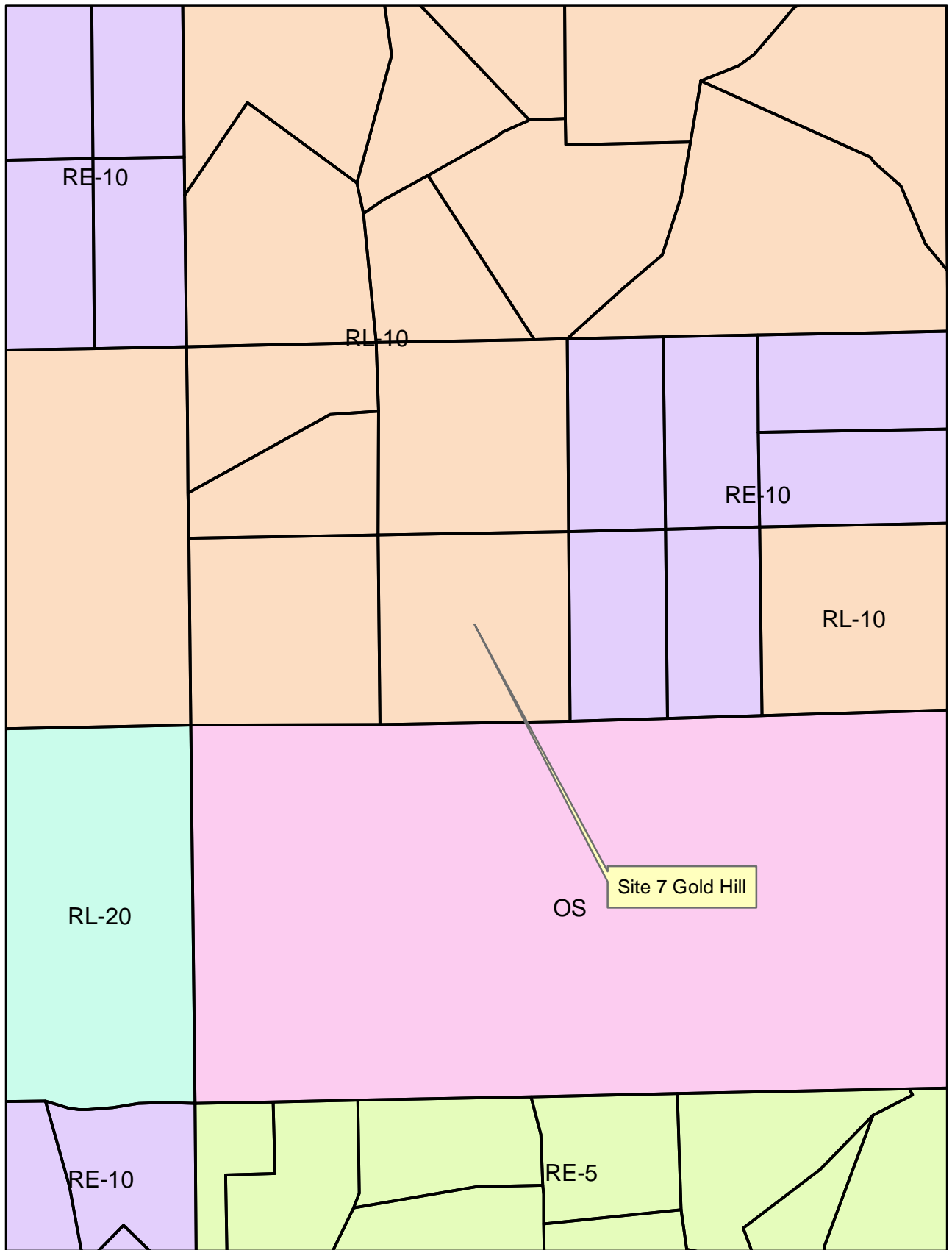

S17-0016/AT&T CAF4
 Site 7 Gold Hill
 Zoning Map
 Exhibit D



- OS
- RE-10
- RE-5
- RL-10
- RL-20

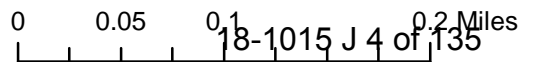



S17-0016/AT&T CAF4
Site 7 Gold Hill
Aerial Map
Exhibit E



0 0.05 0.1 0.2 Miles
18-1015 J 5 of 135



at&t

SITE NUMBER: CVL03054 SITE NAME: GOLD HILL

6812 GODS WAY
LOTUS, CA 95651

PROPRIETARY INFORMATION
THE INFORMATION CONTAINED IN THIS SET OF DRAWINGS IS PROPRIETARY BY NATURE. ANY USE OR DISCLOSURE OTHER THAN THAT WHICH RELATES TO PEEK SITE-COM IS STRICTLY PROHIBITED

CLIENT:



2600 CAMINO RAMON
SAN RAMON, CA 94583

PROJECT INFORMATION:

GOLD HILL

6812 GODS WAY
LOTUS, CA 95651

REV: DATE: DESCRIPTION: BY:

1	6-5-17	90% ZONING DOCUMENTS	AMP
1	8-3-17	95% ZONING DOCUMENTS	ALP
2	8-9-17	100% ZONING DOCUMENTS	ALP

COORDINATING ENGINEER:

Peek Site-Com
 12852 Earhart Ave. Suite 101
 Auburn, California 95602
 Phone (530) 885-6160
 E-Mail info@peeksitecom.com

SEAL:



SITE #: CVL03054 CHK.: ... DRAWN BY: AMP

SHEET TITLE: TITLE SHEET

SHEET NUMBER: T-1 REVISION: 0

SHEET NUMBER: T-1 REVISION: 0

SHEET NUMBER: T-1 REVISION: 0

SHEET NUMBER: T-1 REVISION: 0

SHEET NUMBER: T-1 REVISION: 0

SHEET NUMBER: T-1 REVISION: 0

SHEET NUMBER: T-1 REVISION: 0

SHEET NUMBER: T-1 REVISION: 0

SHEET NUMBER: T-1 REVISION: 0

SHEET NUMBER: T-1 REVISION: 0

SHEET NUMBER: T-1 REVISION: 0

SHEET NUMBER: T-1 REVISION: 0

SHEET NUMBER: T-1 REVISION: 0

SHEET NUMBER: T-1 REVISION: 0

PROJECT INFORMATION

APPLICANT:
AT&T MOBILITY
2600 CAMINO RAMON
SAN RAMON, CA 94583

CONSTRUCTION MANAGER:
PETE MANAS
EPIC WIRELESS
8700 AUBURN FOLSOM ROAD, SUITE 400
GRANITE BAY, CA 95746
(530) 383-5957

SITE SURVEY
GIL ENGINEERING
1226 HIGH STREET
AUBURN, CA 95603
(530) 885-0426

RF ENGINEER:
MUHAMMAD AHMED
MA912P@ATT.COM

RFDS VERSION/DATE:
1.00.01 / 04-28-17

ENGINEERING FIRM:
PEEK SITE-COM
12852 EARHART AVE SUITE 101
AUBURN, CA 95602
(530) 885-6160

SITE ACQUISITION & PLANNING:
JARED KEARSLEY
EPIC WIRELESS
8700 AUBURN FOLSOM ROAD, SUITE 400
GRANITE BAY, CA 95746
(916) 755-1326

CIVIL VENDOR:
VINCOLUMS CONSTRUCTION MANAGER
KEN ABEL
KABEL@VINCOLUMS.COM
(916) 844-4602

PROJECT TEAM

SITE NAME:
SITE NUMBER:
FA LOCATION#:

GOLD HILL
CVL03054
13787671

SITE ADDRESS:

6812 GODS WAY
LOTUS, CA 95651

ASSESSORS PARCEL NUMBER:
LATITUDE:
LONGITUDE:
GROUND ELEVATION:

105-110-81-100
38.802403°
-120.937256°
1102' AMSL

ZONING:
JURISDICTION:
COUNTY:

RL-10
EL DORADO COUNTY
EL DORADO

PROPERTY OWNER:
OWNER ADDRESS:

ANNE L STROUD TR, RODGER STROUD AND KATHLEEN STROUD
6812 GODS WAY
LOTUS, CA 95651

POWER AGENCY:

PG&E
525 MARKET ST, SPEAR TOWER
SAN FRANCISCO, CA 94105
PHONE: 1 (800) 310-2355

TELEPHONE AGENCY:

AT&T

SHEET INDEX

T-1
GN-1
GN-2
C-1
C-2
C-3
C-4
A-1
A-2
A-3
A-3.1
A-4
A-4.1

TITLE SHEET
GENERAL NOTES
SITE SIGNAGE
SITE SURVEY
EROSION CONTROL PLAN & DETAILS
GRADING NOTES & DETAILS
GRADING PLAN
OVERALL SITE PLAN
EQUIPMENT PLAN
ANTENNA PLAN & DETAILS
DETAILS
ELEVATIONS
ELEVATIONS

CODE COMPLIANCE

ALL WORK AND MATERIALS SHALL BE PERFORMED AND INSTALLED IN ACCORDANCE WITH THE CURRENT EDITIONS OF THE FOLLOWING CODES AS ADOPTED BY THE LOCAL GOVERNING AUTHORITIES. NOTHING IN THESE PLANS IS TO BE CONSTRUED TO PERMIT WORK NOT CONFORMING TO THESE CODES.

- 2016 CALIFORNIA BUILDING CODE
- 2016 CALIFORNIA FIRE CODE
- 2016 CALIFORNIA ELECTRICAL CODE
- 2016 CALIFORNIA PLUMBING CODE
- 2016 CALIFORNIA MECHANICAL CODE
- 2016 CALIFORNIA HEALTH AND SAFETY CODE

VICINITY MAP

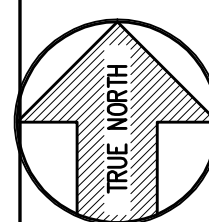
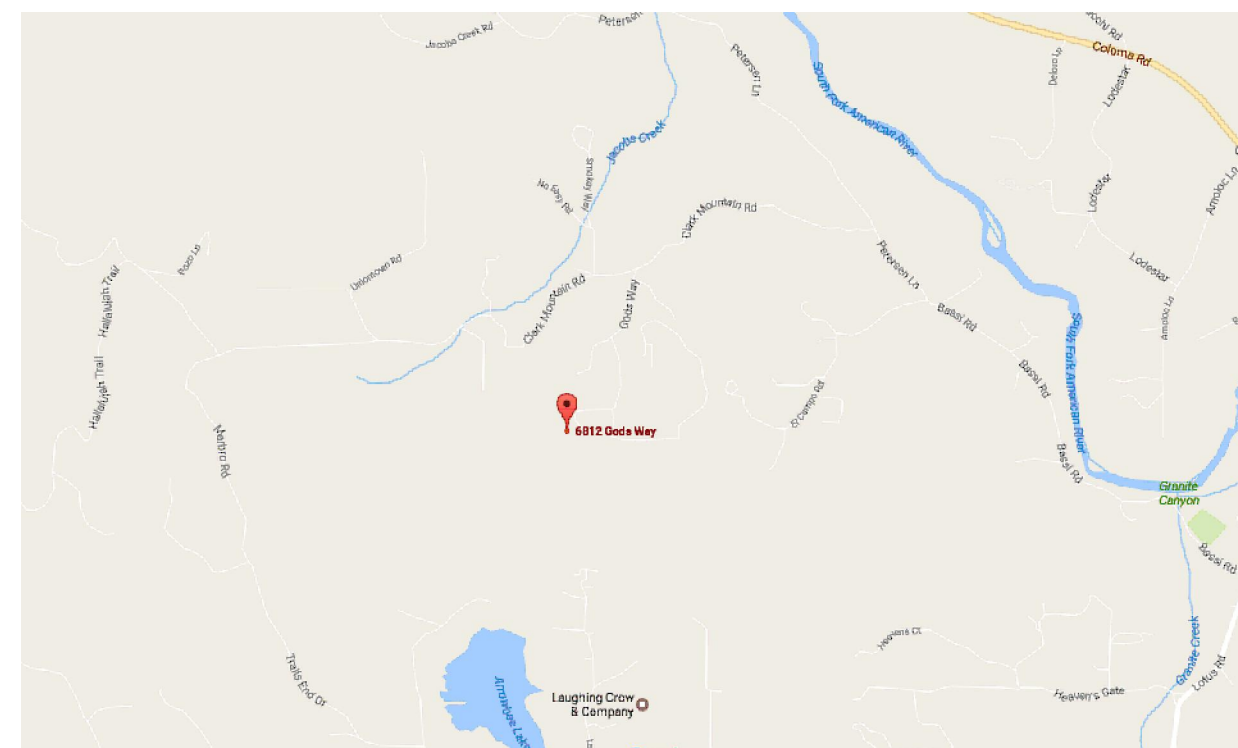

SITE LOCATION

DIRECTIONS FROM AT&T

DIRECTIONS FROM AT&T'S OFFICE AT 2600 CAMINO ROMAN
SAN ROMAN, CA 94583

Summary: 126.4 miles (2 hours, 2 minutes)

Depart San Ramon on I-680 N
Take Ramp (RIGHT) onto I-80 E
Road name changes to I-80 Branch TO US-50
Exit 37 Ponderosa Turn LEFT (North) onto Ponderosa Rd
Turn RIGHT (East) onto N Shingle Rd
Keep STRAIGHT onto Green Valley Rd
Keep STRAIGHT onto Lotus Rd
Turn LEFT (West) onto Bassi Rd
Bear RIGHT (North) onto Petersen Ln
Turn LEFT (West) onto Clark Mountain Rd
Turn LEFT (South) onto Gods Way

Arrive 6812 Gods Way, Lotus, CA 95651

PROJECT DESCRIPTION

AT&T PROPOSES TO CONSTRUCT A NEW UNMANNED TELECOMMUNICATIONS FACILITY. AT&T WILL INSTALL:

- (1) NEW 12' WIDE GRAVEL ACCESS ROAD
- (1) NEW 35'X40' FENCED LEASE AREA
- (1) NEW 6' CHAIN LINK FENCE
- (1) NEW 12' WIDE DOUBLE ACCESS GATE
- (1) NEW 112' MONOPINE
- (1) NEW PRE-FAB LIGHT WEIGHT EQUIPMENT SHELTER
- (1) NEW GPS ANTENNA
- (1) NEW 35kw PROPANE GENERATOR
- (1) LP PROPANE TANK (500 GALLON)
- (12) NEW ANTENNAS
- (9) NEW RRUS-11, (9) NEW RRUS-32 & (3) FUTURE RRUS
- (4) NEW SURGE SUPPRESSORS
- (2) FUTURE 4' M/W DISH

OCCUPANCY & CONST. TYPE

OCCUPANCY: U (UNMANNED)

CONSTRUCTION TYPE: V-B

SPECIAL INSPECTIONS

*SEE SPECIAL INSPECTION FORM

- POST-INSTALLED ANCHORS
- HIGH STRENGTH BOLTING

Exhibit F
Site 7 Gold Hill

ACCESSIBILITY REQUIREMENTS:
THIS FACILITY IS UNMANNED AND NOT FOR HUMAN HABITATION, HANDICAPPED ACCESS REQUIREMENTS ARE NOT REQUIRED IN ACCORDANCE WITH THE 2016 CALIFORNIA BUILDING CODE, CHAPTER 11B, EXCEPTION SECTION 11B-203.5

APPROVALS

APPROVED BY:	INITIALS:	DATE:
AT&T:		
VENDOR:		
R.F.:		
LEASING/LANDLORD:		
ZONING:		
CONSTRUCTION:		
POWER/TELCO:		
PG&E:		

GENERAL CONTRACTOR NOTES

DO NOT SCALE DRAWINGS

THESE DRAWINGS ARE FORMATTED TO BE FULL SIZE 24"X36". CONTRACTOR SHALL VERIFY ALL PLANS AND EXISTING DIMENSIONS AND CONDITIONS ON THE JOBSITE AND SHALL IMMEDIATELY NOTIFY THE ARCHITECT/ENGINEER IN WRITING OF ANY DISCREPANCIES BEFORE PROCEEDING WITH THE WORK OR MATERIAL ORDERS OR BE RESPONSIBLE FOR THE SAME.



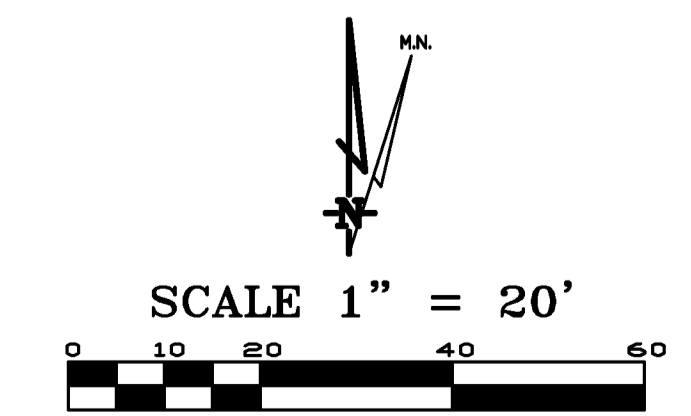
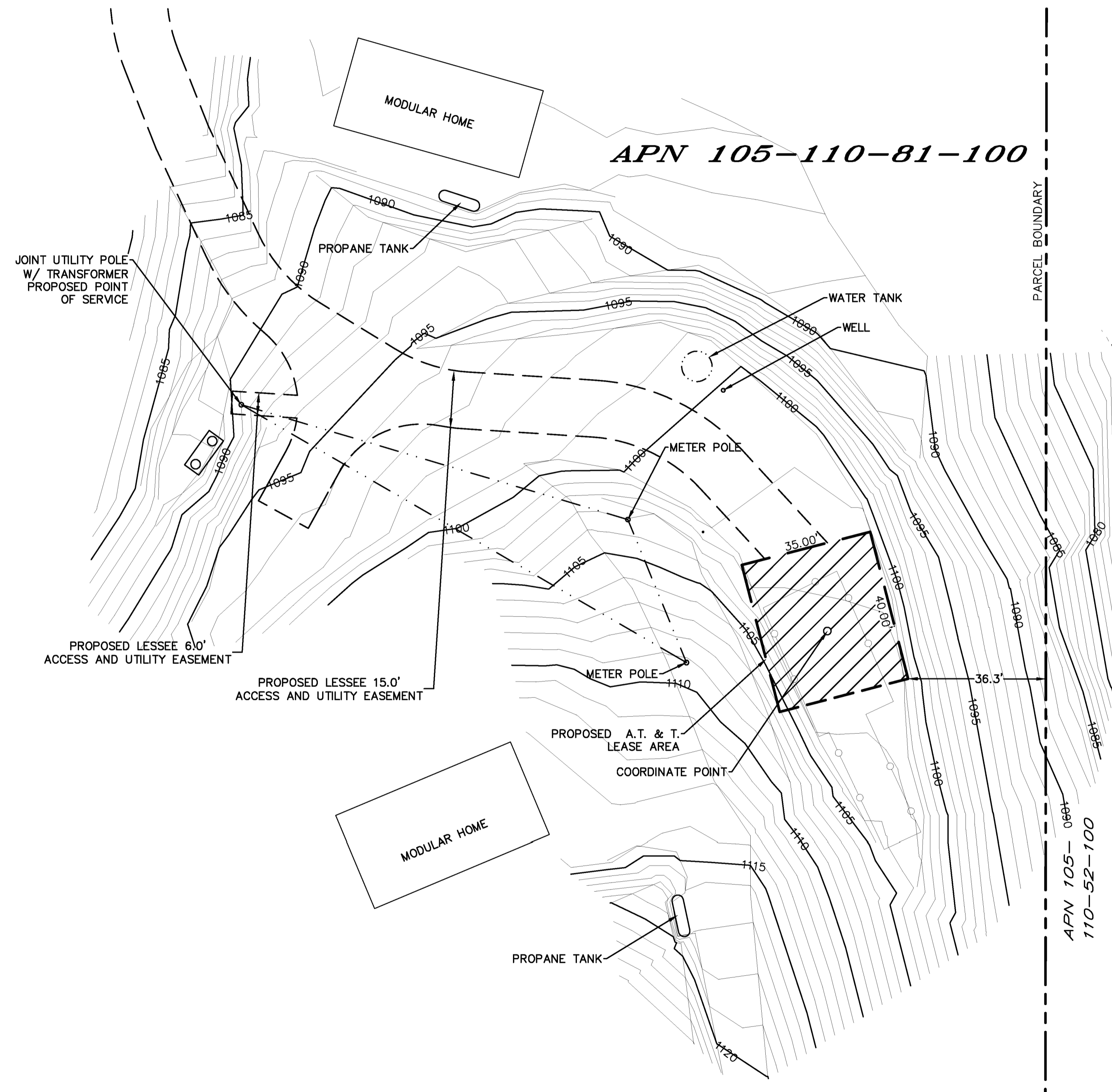

LEASE AREA DETAIL

DATE OF SURVEY: 05-09-17
 SURVEYED BY OR UNDER DIRECTION OF: KENNETH D. GEIL, RCE 14803
 LOCATED IN THE COUNTY OF EL DORADO, STATE OF CALIFORNIA
 BEARINGS SHOWN ARE BASED UPON MONUMENTS FOUND AND RECORD INFORMATION. THIS IS NOT A BOUNDARY SURVEY.
 ELEVATIONS SHOWN ON THIS PLAN ARE BASED UPON U.S.G.S. N.A.V.D. 88 DATUM. ABOVE MEAN SEA LEVEL UNLESS OTHERWISE NOTED.
 N.G.V.D. 1929 CORRECTION: SUBTRACT 2.61' FROM ELEVATIONS SHOWN.
 FEMA FIRM:
 CONTOUR INTERVAL: 1 FT.
 ASSESSOR'S PARCEL NUMBER: 105-110-81-100
 LANDLORD(S): ANNE L STROUD TR, ROGER STROUD, KATHLEEN STROUD
 6812 GODS WAY
 LOTUS, CA 95651

Project Name: CVL03054 Gold Hill
 Project Site Location: 6812 Gods Way
 Lotus, CA 95651
 El Dorado County
 Date of Observation: 05-09-17
 Equipment/Procedure Used to Obtain Coordinates: Trimble Pathfinder
 Geo XT post processed with Pathfinder Office software.
 Type of Antenna Mount: Proposed Monopine
 Coordinates
 Latitude: N 38°48'08.65" (NAD83) N 38°48'09.00" (NAD27)
 Longitude: W 120°56'14.12" (NAD83) W 120°56'10.34" (NAD27)
 Latitude: N 38.802403° (NAD83) N 38.802500° (NAD27)
 Longitude: W 120.937256° (NAD83) W 120.936206° (NAD27)
 ELEVATION of Ground at Structure (NAVD88) 1102' AMSL

CVL03054 Gold Hill
 Lease Area Description
 All that certain lease area being a portion "Tract 1" as delineated on the plat filed in Book 30 of Surveys, Page 127 El Dorado County, California Records being a portion of the Southeast quarter of the Northwest of the Southeast Quarter of Section 14, Township 11 North, Range 9 East M.D.M. being located in El Dorado County, California and more particularly described as follows:

Equipment Lease Area
 Commencing at a monument found set for the Southeast corner of the above referenced Tract 1; thence along the East boundary thereof North 0°03'40" East, 279.44 feet thence leaving said East boundary North 89°56'20" West, 36.32 feet to the True Point of Beginning; thence from said point of beginning North 14°28'18" West, 40.00 feet; thence South 75°31'42" West, 35.00 feet; thence South 14°28'18" East, 40.00 feet; thence North 75°31'42" East, 35.00 feet to the True Point of Beginning.

Together with easement for access and utility purposes, fifteen feet in width, the centerline of which is described as follows: Beginning at a point on the Northwest boundary of the above described lease area which bears South 75°31'42" West, 20.17 feet from the North most corner thereof; thence from said point of beginning North 42°35'15" West, 29.14 feet; thence along a tangent curve to the Northwest, having a radius of 50.00 feet and a central angle of 43°44'25"; thence along said curve a distance of 38.17 feet; ; thence North 86°19'39" West, 33.65 feet; thence along a tangent curve to the West, having a radius of 50.00 feet and a central angle of 27°48'18"; thence along said curve a distance of 24.26 feet; ; thence North 58°31'21" West, 23.08 feet; thence along a tangent curve to the Northwest, having a radius of 50.00 feet and a central angle of 33°38'35"; thence along said curve a distance of 29.36 feet; ; thence North 24°52'46" West, 31.35 feet; thence North 21°42'22" West, 21.72 feet; thence along a tangent curve to the North, having a radius of 50.00 feet and a central angle of 38°24'51"; thence along said curve a distance of 33.52 feet; ; thence North 16°42'29" East, 11.48 feet; thence along a tangent curve to the North, having a radius of 50.00 feet and a central angle of 43°47'39"; thence along said curve a distance of 38.22 feet; ; thence North 60°30'08" East, 40.98 feet; thence along a tangent curve to the Northeast, having a radius of 50.00 feet and a central angle of 23°29'34"; thence along said curve a distance of 20.50 feet; ; thence North 83°59'42" East, 156.78 feet to the existing non-exclusive road and public utility easement as shown on that certain plat filed in Book 10 of Parcel Maps at Page 39, El Dorado County Records; thence along said easement to the public right of way.

Also together with easement, six feet in width, from the above described lease area to the nearest or most convenient utility service connection location.

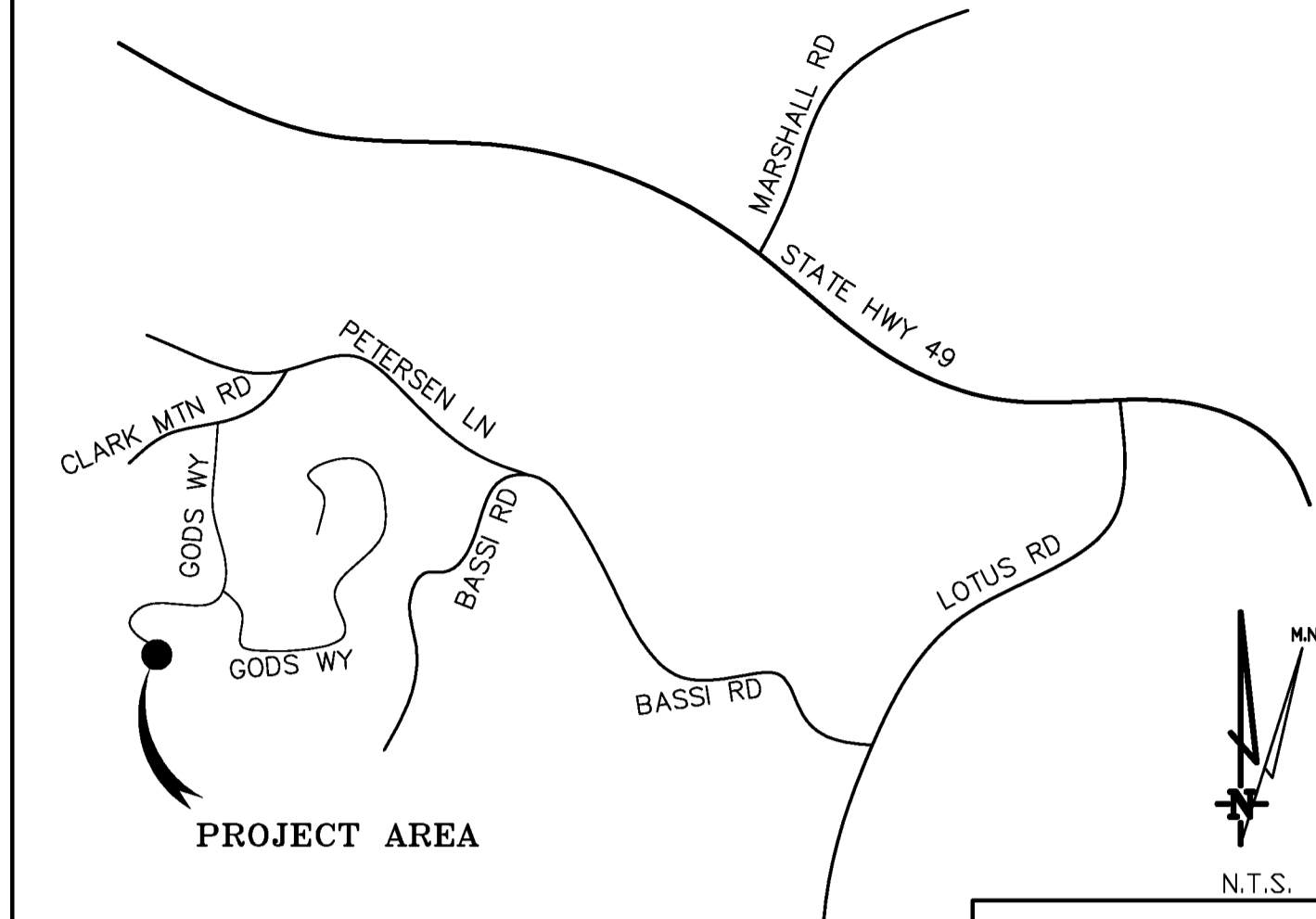

LOTUS, CA VICINITY MAP

THESE DRAWINGS AND/OR THE ACCOMPANYING SPECIFICATION AS INSTRUMENTS OF SERVICE, ARE THE EXCLUSIVE PROPERTY OF GEIL ENGINEERING AND THEIR USE AND PUBLICATION SHALL BE RESTRICTED TO THE ORIGINAL SITE AND CARRIER FOR WHICH THEY ARE PREPARED. REUSE, REPRODUCTION OR PUBLICATION BY ANY METHOD, IN WHOLE OR IN PART, IS PROHIBITED EXCEPT BY WRITTEN PERMISSION FROM GEIL ENGINEERING. TITLE TO THESE PLANS AND/OR SPECIFICATIONS SHALL REMAIN WITH GEIL ENGINEERING WITHOUT PREJUDICE AND VISUAL CONTACT WITH THEM SHALL CONSTITUTE PRIMA FACIE EVIDENCE OF ACCEPTANCE OF THESE RESTRICTIONS.

BOUNDARY SHOWN IS BASED ON MONUMENTATION FOUND AND RECORD INFORMATION. THIS IS NOT A BOUNDARY SURVEY. THIS IS A SPECIALIZED TOPOGRAPHIC MAP WITH PROPERTY LINES AND EASEMENTS BEING A GRAPHIC DEPICTION BASED ON INFORMATION GATHERED FROM VARIOUS SOURCES OF RECORD AND AVAILABLE MONUMENTATION FOUND DURING THE FIELD SURVEY. NO EASEMENTS WERE RESEARCHED OR PLOTTED. PROPERTY LINES AND LINES OF TITLE WERE NOT INVESTIGATED NOR SURVEYED. NO PROPERTY MONUMENTS WERE SET.

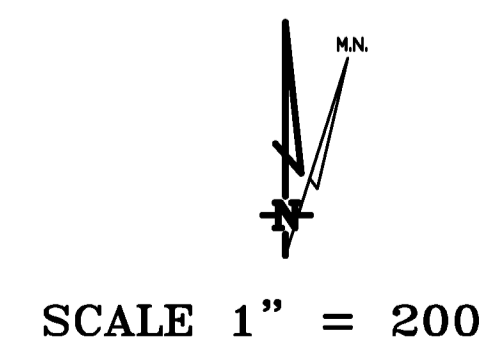
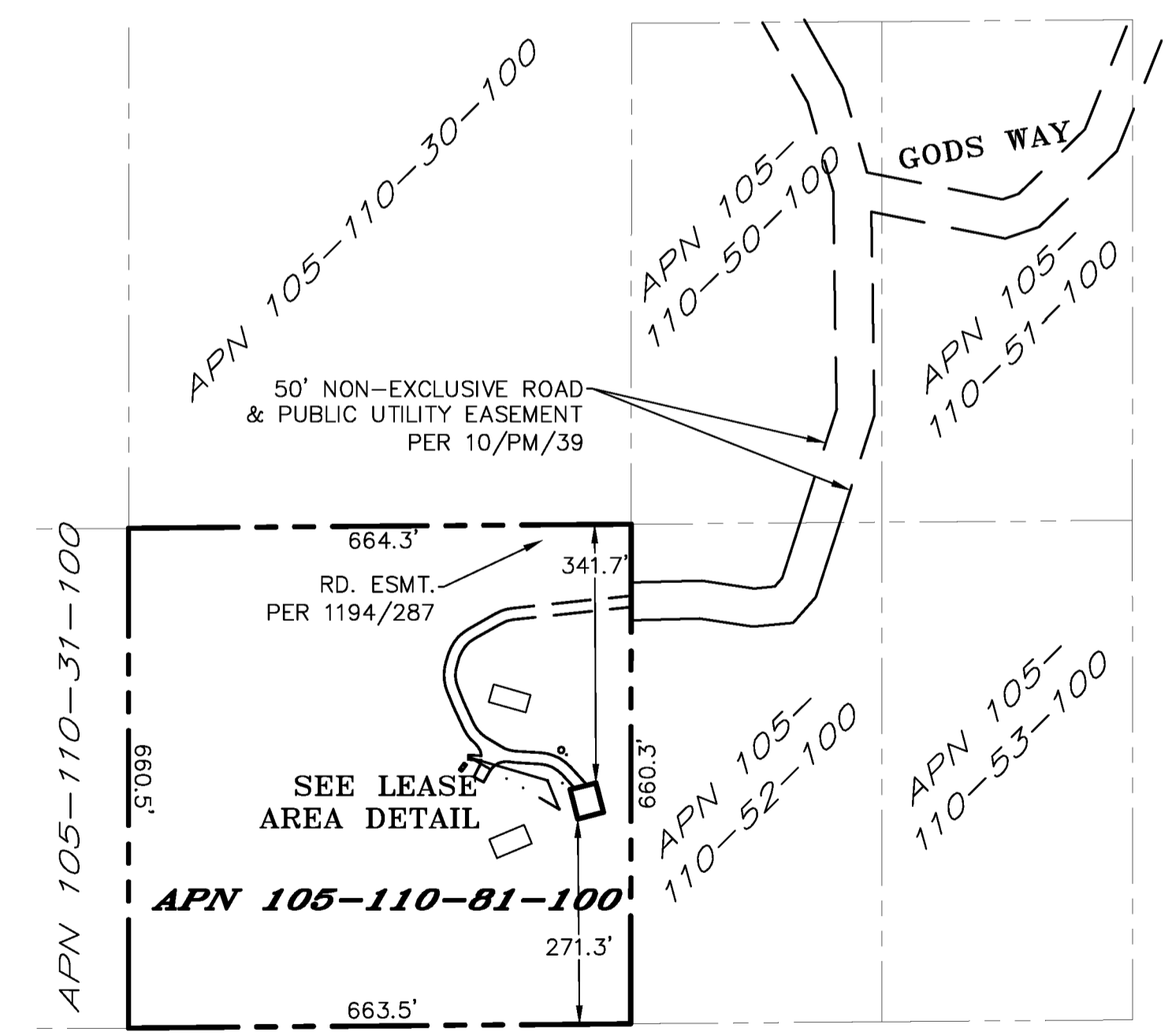

OVERALL PROJECT AREA

DEPT	APPROVED	DATE
ARC		
RE		
RF		
INT		
EE\IN		
OPS		
EE\OUT		

Surveyor
GEIL ENGINEERING
 ENGINEERING • SURVEYING • PLANNING
 1526 HIGH STREET
 AUBURN, CALIFORNIA 96905
 Phone: (530) 838-1000
 Fax: (530) 838-1006

at&t
 MOBILITY

CVL03054 Gold Hill
 6812 Gods Way
 Lotus, CA 95651
 PLOT PLAN AND
 SITE TOPOGRAPHY

REVISIONS	REV	DATE	DESCRIPTION
	05-10-17		Preliminary Drawing
	08-08-17		rev. lease area

Sheet
C-1

GENERAL NOTES

- 1. THE CONTRACTOR SHALL HAVE A RESPONSIBLE PARTY, WHO SHALL HAVE THE AUTHORITY TO REPRESENT AND ACT FOR THE CONTRACTOR, ON THE JOB SITE DURING ALL WORKING HOURS.
- 2. ALL WORK SHALL BE ACCOMPLISHED TO THE SATISFACTION OF THE WASHOE COUNTY AUTHORIZED REPRESENTATIVE.

DEFINITIONS:

- (ESC) = EROSION AND SEDIMENT CONTROL
- (NPDES) = NATIONAL POLLUTANT DISCHARGE ELIMINATION SYSTEM
- (CWA) = CLEAN WATER ACT
- (SWPPP) = STORM WATER POLLUTION PREVENTION PLAN
- (BMP'S) = BEST MANAGEMENT PRACTICES

THE CONTRACTOR SHALL:

MAKE HIM/HERSELF AWARE OF THE REQUIREMENTS OF SAID GENERAL PERMIT AND THE PROVISIONS OF THE GRADING & EROSION CONTROL PLANS.

IMPLEMENT THE ESC FEATURES AND BEST MANAGEMENT PRACTICES (BMP'S) CONTAINED IN THE IMPROVEMENT PLANS, AND OTHERWISE DILIGENTLY PURSUE COMPLIANCE WITH THE LOCAL REQUIREMENTS.

ASSIST THE OWNER, ENGINEER, AND PUBLIC WORKS DEPARTMENT STAFF IN THE ASSESSMENT OF THE FUNCTIONALITY OF AND MODIFICATIONS TO THE FEATURES AND PRACTICES IMPLEMENTED AND PROPOSED.

MEET WITH THE OWNER AND THE PUBLIC WORKS DEPARTMENT STAFF TO DETERMINE AND DISCUSS THE STATUS OF THE PROJECT, CONSTRUCTION SCHEDULE, AND ANY MODIFICATIONS AND/OR ADDITIONS TO THE ESC FEATURES IN ORDER TO DILIGENTLY PURSUE COMPLIANCE.

DOCUMENT ANY MAINTENANCE, REPLACEMENT, INSPECTION, MODIFICATIONS OR ADDITIONS TO THE PROJECT ESC FEATURES, AND NOTIFY THE ENGINEER, OWNER AND PUBLIC WORKS DEPARTMENT STAFF OF ANY SUBSTANTIAL MODIFICATIONS OR ADDITIONS TO THE ESC PRACTICES AND FEATURES. ALL DISTURBED AREAS SHALL BE PROTECTED WITH APPROVED MATERIALS WITHIN 15 DAYS OF COMPLETION OF THE FINISHED GRADES.

MAINTAIN AN INVENTORY OF ESC MATERIALS (STRAW BALES, 1.5" - 3" CLEAN CRUSHED ROCK, FIBER ROLLS, SILT FENCE, ROCK BAGS, ETC.) ON SITE FOR EMERGENCY USE AS DIRECTED BY THE ENGINEER, OWNER, OR THE PUBLIC WORKS DEPARTMENT STAFF.

OTHER RESPONSIBILITIES OF APPLICANT:

- A. PROTECTION OF UTILITIES. THE APPLICANT SHALL BE RESPONSIBLE FOR THE PREVENTION OF DAMAGE TO ANY PUBLIC UTILITIES OR SERVICES.
- B. PROTECTION OF ADJACENT PROPERTY. THE APPLICANT SHALL BE RESPONSIBLE.
- C. FOR THE PREVENTION OF DAMAGE TO ADJACENT PROPERTY. NO PERSON(S) SHALL EXCAVATE ON LAND THAT IS SO CLOSE TO THE PROPERTY LINE AS TO ENDANGER ANY ADJOINING PUBLIC STREET, SIDEWALK, ALLEY, STRUCTURE OR OTHER PUBLIC OR PRIVATE PROPERTY OR EASEMENT WITHOUT SUPPORTING AND PROTECTING SUCH PROPERTY FROM ANY DAMAGE WHICH MIGHT OTHERWISE RESULT.
- D. ADVANCE NOTICE. THE APPLICANT SHALL NOTIFY THE COUNTY AT LEAST FORTY-EIGHT HOURS PRIOR TO THE START OF WORK.
- E. EROSION AND SEDIMENT CONTROL. IT SHALL BE THE SOLE RESPONSIBILITY OF THE APPLICANT TO PREVENT DISCHARGE OF SEDIMENT FROM THE SITE, IN QUANTITIES GREATER THAN BEFORE THE GRADING OCCURRED, TO ANY WATERCOURSE, DRAINAGE SYSTEM, OR ADJACENT PROPERTY.
- F. COMPLIANCE WITH STORMWATER RUNOFF POLLUTION CONTROL CODE. AT ALL TIMES DURING THE PRECONSTRUCTION AND CONSTRUCTION OF ANY PROJECT FOR WHICH GRADING APPROVAL IS ISSUED UNTIL ALL FINAL IMPROVEMENTS AND PERMANENT STRUCTURES ARE COMPLETE, THE APPLICANT SHALL FULLY COMPLY WITH ALL APPLICABLE REQUIREMENTS OF THE STORMWATER RUNOFF POLLUTION CONTROL CODE.

EROSION CONTROL NOTES

- 1. ALL EROSION AND SEDIMENT CONTROL MEASURES SHALL BE CONSTRUCTED AND MAINTAINED IN ACCORDANCE WITH THE COUNTY IMPROVEMENT STANDARDS, CURRENT EDITION, AND THE COUNTY EROSION AND SEDIMENT CONTROL GUIDELINES.
- 2. EROSION CONTROL BEST MANAGEMENT PRACTICES (BMP'S) SHALL BE INSTALLED AND MAINTAINED DURING THE WET SEASON (OCTOBER THROUGH APRIL 30). SEDIMENT CONTROL BMP'S SHALL BE INSTALLED AND MAINTAINED ALL YEAR.
- 3. ALL DRAINAGE INLETS IMMEDIATELY DOWNSTREAM OF THE WORK AREAS AND WITHIN THE WORK AREAS SHALL BE PROTECTED WITH SEDIMENT CONTROL AND INLET FILTER BAGS, YEAR ROUND. INLET FILTER BAGS SHALL BE REMOVED FROM THE DRAINAGE INLETS UPON ACCEPTANCE OF THE PUBLIC IMPROVEMENTS BY THE COUNTY.
- 4. ALL AREAS DISTURBED DURING CONSTRUCTION, BY GRADING, TRENCHING, OR OTHER ACTIVITIES, SHALL BE PROTECTED FROM EROSION DURING THE WET SEASON (OCTOBER 1 THROUGH APRIL 30). HYDROSEED, IF UTILIZED, MUST BE PLACED BY SEPTEMBER 15. HYDROSEED PLACED DURING THE WET SEASON SHALL USE A SECONDARY EROSION PROTECTION METHOD.
- 5. SENSITIVE AREAS AND AREAS WHERE EXISTING VEGETATION IS BEING PRESERVED SHALL BE PROTECTED WITH CONSTRUCTION FENCING. SEDIMENT CONTROL BMP'S SHALL BE INSTALLED WHERE ACTIVE CONSTRUCTION AREAS DRAIN INTO SENSITIVE OR PRESERVED VEGETATION AREAS.
- 6. SEDIMENT CONTROL BMP'S SHALL BE PLACED ALONG THE PROJECT PERIMETER WHERE DRAINAGE LEAVES THE PROJECT. SEDIMENT CONTROL BMP'S SHALL BE MAINTAINED YEAR ROUND UNTIL THE CONSTRUCTION IS COMPLETE OR THE DRAINAGE PATTERN HAS BEEN CHANGED AND NO LONGER LEAVES THE SITE.
- 7. THE FOLLOWING AREAS ARE TO RECEIVE HYDROSEEDING OR OTHER EROSION CONTROL: ALL SLOPES GREATER THAN 10:1.
- 8. FOR DEWATERING OPERATIONS, SEDIMENT- LADEN STORM WATER SHALL BE EITHER PUMPED (NOTE 10) OR ROUTED (TEMPORARY DIVERSION SWALE) TO SEDIMENT TRAP(S) TO ALLOW SEDIMENT TO SETTLE OUT BEFORE DISCHARGE OFF-SITE. ONCE SEDIMENT HAS SETTLED OUT, WATER WILL BE DISCHARGED THROUGH SWALE LINED WITH IMPERVIOUS PLASTIC LINER.
- 9. USE OF FIBER ROLLS SHALL BE AUGMENTED DURING WET SEASON WITH DEWATERING BMP'S IN THE EVENT THAT FIBER ROLLS DO NOT EFFECTIVELY RETAIN STORM WATER ON SITE. DEWATERING MAY INCLUDE PUMPS OR BERMS TO ROUTE WATER TO THE SEDIMENT TRAP. IF PUMPS ARE USED, THEN FILTER BAGS SHALL BE USED AT DISCHARGE HOSE ENDS. DEWATERING MATERIAL SHALL NOT BE DISCHARGED DIRECTLY TO THE STORM DRAIN SYSTEM.

BMP INSTALLATION SCHEDULE

BEST MANAGEMENT PRACTICE	LOCATION	IMPLEMENTATION SCHEDULE	MAINTENANCE SCHEDULE
A. PRESERVING EXISTING VEGETATION	AROUND PERIMETER OF PROJECT SITE	CONTINUOUS, UNTIL CONSTRUCTION IS COMPLETED	EDUCATE EMPLOYEES AND SUBCONTRACTORS REGARDING IMPORTANCE AT MAINTAINING EXISTING VEGETATION TO PREVENT EROSION AND FILER AND SEDIMENT IN RUNOFF FROM DISTURBED AREAS ON THE CONSTRUCTION SITE. INSPECT SITE PERIMETER MONTHLY TO VERIFY THE OUTSIDE VEGETATION IS NOT DISTURBED.
B. PROTECT GRADED AREAS AND SLOPES FROM WASHOUT & EROSION	THROUGHOUT PROJECT SITE	DURING WET SEASON	INSPECT GRADED AREAS AND SLOPES ON AT LEAST A MONTHLY BASIS TO CHECK FOR EROSION. REGRADE TRIBUTARY AREAS OR INSTALL FILTER BARRIER OR SAND BAG DIKES AS NECESSARY TO PREVENT EROSION.
C. GRAVEL FILTER	ALONG FLOW LINES OF UNPAVED ROADWAYS WITHIN SITE	IN PLACE DURING WET SEASON UNTIL ROADWAYS ARE PAVED	INSPECT DAILY AND AFTER EACH STORM. REMOVE ON-SITE SEDIMENT DEPOSITED BEHIND BERM OR BARRIER TO MAINTAIN EFFECTIVENESS.
D. INLET FILTER BAG	INLETS TO THE STORM DRAINAGE SYSTEM	CONTINUOUS UNTIL LANDSCAPING IS IN PLACE	INSPECT WEEKLY AND AFTER EACH STORM. REMOVE SEDIMENT AND DEBRIS BEFORE ACCUMULATIONS HAVE REACHED ONE THIRD THE DEPTH OF THE BAG. REPAIR OR REPLACE INLET FILTER BAG AS SOON AS DAMAGE OCCURS.
E. FIBER ROLL	SEE PLAN SHEET C-4	CONTINUOUS	INSPECT WEEKLY AND AFTER EACH STORM. REMOVE SEDIMENT DEPOSITED BEHIND FIBER ROLL WHENEVER NECESSARY TO MAINTAIN EFFECTIVENESS.
F. HYDROSEEDING	3:1 SLOPES	IN PLACE DURING BY SEPT. 15	INSPECT SLOPES ON AT LEAST A MONTHLY BASIS TO CHECK FOR EROSION. IF EROSION IS NOTED, SPREAD STRAW MULCH OVER AFFECTED AREAS.
G. STABILIZED CONSTRUCTION ENTRANCE	ENTRANCES TO SITE FROM PUBLIC ROADWAYS	CONTINUOUS, UNTIL ENTRANCES AND ON-SITE ROADWAYS ARE PAVED	INSPECT ON A MONTHLY BASIS AND AFTER EACH RAINFALL. ADD AGGREGATE BASE MATERIAL WHENEVER NECESSARY TO PREVENT SEDIMENT FROM BEING TRACKED INTO PUBLIC STREET.
H. WIND EROSION CONTROL PRACTICES	WHEREVER NECESSARY THROUGHOUT PROJECT SITE	CONTINUOUS UNTIL GRADING IS COMPLETED AND SOILS HAVE STABILIZED	INSPECT SITE DURING WINDY CONDITIONS TO IDENTIFY AREAS WHERE WIND EROSION IS OCCURRING AND ABATE EROSION AS NECESSARY
I. GOOD HOUSEKEEPING MEASURES	THROUGHOUT PROJECT SITE	CONTINUOUS UNTIL CONSTRUCTION IS COMPLETED	INSPECT SITE ON AT LEAST A MONTHLY BASIS TO VERIFY THAT GOOD HOUSEKEEPING PRACTICES ARE BEING IMPLEMENTED.
J. PROPER CONSTRUCTION MATERIAL STORAGE	DESIGNATED AREA	CONTINUOUS UNTIL CONSTRUCTION IS COMPLETED	INSPECT SITE ON AT LEAST A WEEKLY BASIS TO VERIFY THAT CONSTRUCTION MATERIALS ARE STORED IN A MANNER, WHICH COULD NOT CAUSE STORM WATER POLLUTION.
K. PROPER CONSTRUCTION WASTE STORAGE AND DISPOSAL INCLUDING 1) CONCRETE SPILL CLEANUP INCLUDING PAINT & PAINTING SUPPLIES 2) VEHICLE FUELING MAINTENANCE & CLEANING	DESIGNATED COLLECTION AREA AND CONTAINERS MATERIAL HANDLING AREA DESIGNATED AREA WITH SECONDARY CONTAINMENT	CONTINUOUS UNTIL CONSTRUCTION IS COMPLETED IMMEDIATELY AT TIME OF SPILL CONTINUOUS	INSPECT MATERIAL HANDING AREAS ON AT LEAST A MONTHLY BASIS TO VERIFY PROPER SPILL CLEANUP. KEEP AMPLE SUPPLIES OF SPILL CLEANUP MATERIALS ON SITE & INSPECT ON REGULAR SCHEDULE.
L. STREET AND STORM DRAINAGE FACILITIES MAINTENANCE DEFINITIONS	STREETS AND STORM DRAINAGE FACILITIES	CONTINUOUS UNTIL CONSTRUCTION IS COMPLETED	MAINTAIN STORM DRAINAGE FACILITIES AND PAVED STREETS CLEAR OF SEDIMENT AND DEBRIS.

1. WET SEASON: ENTIRE PERIOD BETWEEN OCTOBER 1 THROUGH APRIL 30. CONTRACTOR SHALL ALSO IMPLEMENT WET SEASON MEASURES IF WET WEATHER IS EXPECTED DURING THE DRY SEASON.
2. PHASES OF GRADING:
INITIAL (STAGE 1): WHEN CLEARING AND GRUBBING ACTIVITIES OCCUR.
ROUGH (STAGE 2): WHEN CUT AND FILL ACTIVITIES OCCUR AND THE SITE IMPROVEMENTS ARE CONSTRUCTED, INCLUDING UNDERGROUND PIPING, STREETS, SIDEWALKS, AND OTHER IMPROVEMENTS.
FINAL (STAGE 3): WHEN FINAL ELEVATIONS ARE SET, AND SITE IMPROVEMENTS ARE COMPLETED AND READY FOR COUNTY ACCEPTANCE.



ER-1 PORTABLE CONCRETE WASHOUT CONTAINER
NO SCALE

INSPECTION & MAINTENANCE OF FIBER ROLLS:

- REPAIR OR REPLACE SPLIT, TORN, UNRAVELING OR SLUMPING FIBER ROLLS.
 - INSPECT FIBER ROLLS WHEN RAIN IS FORECAST, FOLLOWING RAIN EVENTS, AT LEAST DAILY DURING PROLONGED RAINFALL, AND AT TWO-WEEK INTERVALS DURING THE NON-RAIN SEASON.
 - SEDIMENT SHOULD BE REMOVED WHEN SEDIMENT ACCUMULATION REACHES ONE-HALF THE DESIGNATED SEDIMENT STORAGE DEPTH, USUALLY ONE-HALF THE DISTANCE BETWEEN THE TOP OF THE FIBER ROLL AND THE ADJACENT GROUND SURFACE. SEDIMENT REMOVED DURING MAINTENANCE MAY BE INCORPORATED INTO THE EARTHWORK ON THE SITE OR DEPOSITED AT AN APPROPRIATE LOCATION.
- NOTES:
- FILTER BARRIER SHALL BE CONSTRUCTED LONG ENOUGH TO EXTEND ACROSS THE EXPECTED FLOW PATH AND AS APPROVED BY THE LANDSCAPE INSPECTOR.
 - FILTER ROLL (8" TO 12" DIAMETER) SHALL BE PLACED INTO THE KEY TRENCH AND STAKES ON BOTH SIDES OF THE ROLL WITHIN 4 FEET OF EACH END AND THEN EVERY 3' TO 4' WITH 1" X 2" X 23" STAKES. STAKES ARE TYPICALLY DRIVEN IN ON ALTERNATING SIDES OF THE ROLL. ADJACENT ROLLS SHALL TIGHTLY ABUT.
 - CLEAR SUBGRADE SO THAT REMOVAL OF ALL LOCAL DEVIATIONS AND TO REMOVE LARGE STONES OR DEBRIS THAT WILL INHIBIT INTIMATE CONTACT OF THE FIBER ROLL WITH THE SUBGRADE.
 - PRIOR TO ROLL INSTALLATION, CONTOUR A CONCAVE TRENCH (2 TO 4 INCHES) DEEP ALONG THE PROPOSED INSTALLATION ROUTE. FIBER ROLL SHALL BE INSTALLED ALONG THE SIDE OF WALKS AND AROUND THE CATCH BASIN. THE BOTTOM EDGE OF THE FIBER ROLL SHALL EXTEND TO AND ACROSS THE BOTTOM OF THE TRENCH. THE TRENCH SHALL BE BACKFILLED TO 4 INCHES ABOVE GROUND AND COMPACTED TO BURY AND SECURE THE BOTTOM OF THE FIBER ROLL.
 - CONTRACTOR SHALL MAKE INSPECTIONS WEEKLY DURING THE WET SEASON, MONTHLY DURING THE DRY SEASON AND IMMEDIATELY AFTER EACH RAINFALL TO DETERMINE IF REPAIRS AND SEDIMENT REMOVAL IS REQUIRED. SEDIMENT SHALL BE REMOVED BEFORE IT HAS REACHED ONE THIRD THE HEIGHT OF THE FILTER FABRIC.

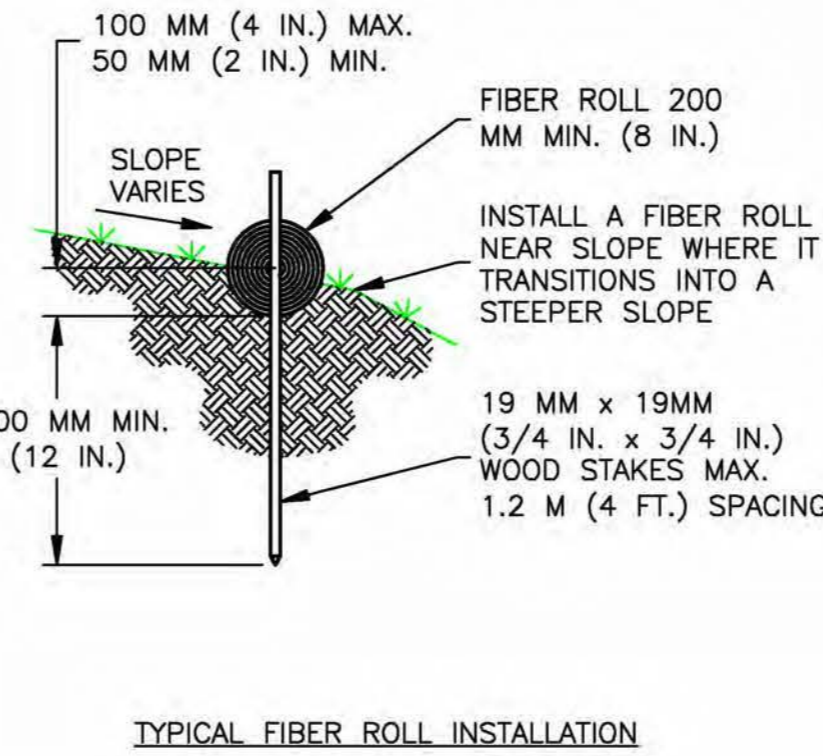

TYPICAL FIBER ROLL INSTALLATION

ER-2 FIBER ROLLS
NO SCALE

REVEGETATION STANDARDS

- PERMANENT REVEGETATION OR LANDSCAPING, IF REQUIRED, IS TO BE COMMENCED ON THE CONSTRUCTION SITE AS SOON AS PRACTICAL AND IN NO CASE EXCEEDING TWELVE MONTHS AFTER ACHIEVING FINAL GRADES AND UTILITY PLACEMENTS. WHENEVER PRACTICAL, LAND IS TO BE DEVELOPED IN INCREMENTS OF WORKABLE SIZE WHICH CAN BE COMPLETED DURING A SINGLE CONSTRUCTION SEASON; EROSION CONTROL MEASURES ARE TO BE COORDINATED WITH THE SEQUENCE OF GRADING OR IMPROVEMENTS.
- ALL SURFACES DISTURBED BY VEGETATION REMOVAL, GRADING, HAUL ROADS, OR OTHER ACTIVITY OF CONSTRUCTION WHICH ALTERS THE NATURAL VEGETATIVE COVER ARE TO BE PREPARED FOR EXPEDITIOUS REVEGETATION OR OTHERWISE MAINTAINED TO CONTROL EROSION UNLESS COVERED WITH IMPERVIOUS OR OTHER IMPROVED SURFACES PURSUANT TO APPROVED PLANS WITHIN FOURTEEN DAYS FOLLOWING THE COMPLETION OF GRADING, OR REMOVAL OF VEGETATION IF NO GRADING WAS INVOLVED.
- TOPSOIL REMOVED FROM THE SURFACE IN PREPARATION FOR GRADING SHALL BE RESTORED TO EXPOSE CUT AND FILL EMBANKMENTS OR BUILDING PADS SO AS TO PROVIDE A SUITABLE BASE FOR SEEDING AND PLANTING.
- ACCEPTABLE METHODS OF REVEGETATION INCLUDE STRAW-MULCHING, HYDRO-MULCHING OR PLANTING OF MIXTURE SPECIFIED IN THE IMPROVEMENT STANDARDS. OTHER METHODS OF REVEGETATION MAY BE APPROVED BY THE COUNTY ENGINEER WHERE EQUIVALENT PROTECTION IS PROVIDED.
- ALL REVEGETATION AND LANDSCAPING ARE TO BE CONDUCTED WITHIN SUITABLE GROWING PERIODS. NATIVE PLANT MATERIALS ARE SPECIFICALLY ENCOURAGED IN ORDER TO REDUCE IRRIGATION DEMANDS.
- TEMPORARY SEDIMENTATION CONTROL FACILITIES ARE TO BE INSTALLED IN CONJUNCTION WITH INITIAL GRADING OPERATIONS AND MAINTAINED THROUGHOUT THE CONSTRUCTION PERIOD TO REMOVE SEDIMENTS FROM RUNOFF WATERS DURING DEVELOPMENT.
- PERMANENT SEDIMENT CATCHMENT BASINS OR OTHER TYPES OF SEDIMENT RETENTION FACILITIES ARE REQUIRED WHEREVER NECESSARY TO PREVENT DISCHARGE OF SEDIMENT INTO WATERS OF THE STATE. SEDIMENT RETENTION FACILITIES SHALL BE INSPECTED AND CLEANED ACCORDING TO A REGULAR MAINTENANCE SCHEDULE.
- THE PLANTING OR SEEDING OF VEGETATIVE PROTECTION MUST BE EFFECTIVE. IF THE VEGETATION DOES NOT GROW AND OFFER PROPER PROTECTION, IT MUST BE REPLANTED OR RESEED.
- THE MAINTENANCE OF VEGETATIVE PROTECTION ON GRADED SLOPES SHALL BE THE RESPONSIBILITY OF THE PERMITEE AND SHALL BE GUARANTEED UNTIL THE VEGETATION IS WELL ESTABLISHED OR IS OFFICIALLY ASSUMED BY ANOTHER PARTY.

DUST MITIGATION PLAN

- SECTION 1: FUGITIVE DUST PREVENTION AND CONTROL
- LAND CLEARING/EARTH MOVING:
WATER SHALL BE APPLIED BY MEANS OF TRUCK(S), HOSES AND/OR SPRINKLERS PRIOR TO ANY LAND CLEARING OR EARTH MOVEMENT TO MINIMIZE DUST EMISSIONS. HAUL VEHICLES TRANSPORTING SOIL INTO OR OUT OF THE PROPERTY SHALL BE COVERED.
- VISIBLY DRY DISTURBED SOIL SURFACE AREAS:
ALL VISIBLY DRY DISTURBED SOIL SURFACE AREAS OF OPERATION SHALL BE WATERED TO MINIMIZE DUST EMISSIONS.
- PAVED ROAD TRACK-OUT:
PAVED ROADS SHALL BE CLEANED IF THE AMOUNT OF DIRT TRACKED-OUT OF THE OPERATION AREA HAS THE POTENTIAL TO CAUSE DUST EMISSIONS.
- VISIBLY DRY DISTURBED UNPAVED DRIVEWAYS:
ALL VISIBLY DRY DISTURBED UNPAVED DRIVEWAY SURFACE AREAS OF OPERATION SHALL BE WATERED TO MINIMIZE DUST EMISSIONS. UNPAVED DRIVEWAYS MAY BE GRAVELED TO REDUCE DUST EMISSIONS.
- VEHICLES ENTERING / EXITING CONSTRUCTION AREA:
VEHICLES ENTERING OR EXITING CONSTRUCTION AREA SHALL TRAVEL AT A SPEED WHICH MINIMIZES DUST EMISSIONS.
- EMPLOYEE VEHICLES:
CONSTRUCTION WORKERS PARK IN DESIGNATED PARKING AREA(S) TO HELP REDUCE DUST EMISSIONS.
- SOIL PILES:
SOIL PILE SURFACES SHALL BE MOISTENED IF DUST IS BEING EMITTED FROM THE PILE(S). ADEQUATELY SECURED TARP, PLASTIC OR OTHER MATERIAL MAY BE REQUIRED TO FURTHER REDUCE DUST EMISSIONS.

REQUIRED BMP'S

- THE FOLLOWING BMP'S SHALL BE REQUIRED ON ALL PROJECTS:
- A. ACCESS POINTS TO THE CONSTRUCTION SITE SHALL HAVE A STABILIZED CONSTRUCTION ACCESS.
 - B. THE PRESERVATION OF EXISTING VEGETATION SHALL BE DONE IN ACCORDANCE WITH PRESERVATION OF EXISTING VEGETATION, AND SILT FENCE.
 - C. PERIMETER PROTECTION ALONG PROPERTY LINES SHALL HAVE PRESERVATION OF EXISTING VEGETATION, OR SILT FENCE.
 - D. SLOPES GREATER THAN 3 PERCENT SHALL BE TEMPORARILY SEEDED AND SLOPES GREATER 3:1 (H:V) SHALL HAVE HYDROSEEDING AND/OR GEOTEXTILES, PLASTIC COVERS, AND/OR EROSION CONTROL BLANKETS INSTALLED.
 - E. THE TOE OF ALL SLOPES SHALL HAVE SILT FENCE AND/OR FIBER ROLL.
 - F. DISTURBED SOIL AREAS BEHIND THE CURB OR BACK OF WALK (OR CURB) SHALL HAVE STRAW MULCH, SOIL BINDERS OR GEOTEXTILES, PLASTIC COVERS, AND EROSION CONTROL BLANKETS/MATS IN CONJUNCTION WITH HYDROSEEDING. SURFACE TREATMENTS SHALL EXTEND TO THE GREATER OF 6 METERS (20 FEET) OR TO THE TOP OF SLOPE.
 - G. ROADWAY SUBGRADES SHALL HAVE FIBER ROLL, SILT FENCE, OR SEDIMENT TRAP.
 - H. DEAD END STREETS, TO BE EXTENDED IN THE FUTURE, SHALL HAVE PRESERVATION OF EXISTING VEGETATION, HYDROSEEDING, SEDIMENT TRAP OR OTHER APPLICABLE BMP TO MINIMIZE THE TRANSPORT OF SEDIMENT ONTO OR FROM THE IMPROVED SURFACE.
 - I. PROJECTS THAT INCLUDE DETENTION BASINS SHALL HAVE A SEDIMENT BASIN.
 - J. PLACE DRAINAGE INLET SEDIMENT BMP'S AT ALL STORM DRAIN INLETS. BMP'S SHALL INCLUDE INLET SEDIMENT CONTROL BARRIER, INLET FILTER BAG AND CONCRETE STAMPS OR EXPLODIED PLAQUARDS.
 - K. EACH CONSTRUCTION SITE SHALL PROVIDE DESIGNATED, PAINT AND WASTE DISPOSAL LOCATIONS AS NECESSARY.
 - L. A BMP INSTALLATION SCHEDULE SHALL BE INCLUDED ON THE IMPROVEMENT PLANS. THE SCHEDULE SHALL INCLUDE THE BMP'S FOR BOTH THE WET SEASON AND THE DRY SEASON.

PROPRIETARY INFORMATION
THE INFORMATION CONTAINED IN THIS SET OF DRAWINGS IS PROPRIETARY BY NATURE. ANY USE OR DISCLOSURE OTHER THAN THAT WHICH RELATES TO PECK SITE-COM IS STRICTLY PROHIBITED



2600 CAMINO RAMON
SAN RAMON, CA 94583

PROJECT INFORMATION:
GOLD HILL
6812 GODS WAY
LOTUS, CA 95651

REV.	DATE	DESCRIPTION	BY
1	6-5-17	90% ZONING DOCUMENTS	AMP
2	8-3-17	95% ZONING DOCUMENTS	ALP
1	8-9-17	100% ZONING DOCUMENTS	ALP

COORDINATING ENGINEER:
Peek Site-Com
12852 Earhart Ave. Suite 101
Auburn, California 95602
Phone (530) 885-6160
E-Mail info@peeksitecom.com

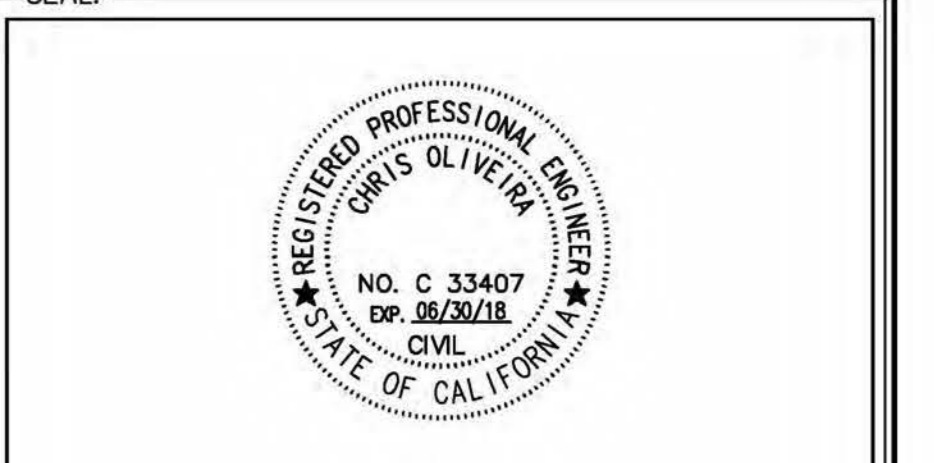

SITE #: _____ CHK.: _____ DRAWN BY: _____
CVL03054 ... AMP

EROSION CONTROL NOTES

SHEET NUMBER: _____ REVISION: _____
C-2 0

GRADING STANDARDS

- 1. GENERAL. UNLESS OTHERWISE RECOMMENDED IN THE APPROVED SOILS ENGINEERING OR ENGINEERING GEOLOGY REPORT, GRADING ACTIVITIES SHALL CONFORM TO THE PROVISIONS OF THIS SECTION.
 - A. CUT SLOPE. THE SLOPE OF CUT SURFACES SHALL BE NO STEEPER THAN IS SAFE FOR THE INTENDED USE AND SHALL BE NO STEEPER THAN 1 UNIT VERTICAL IN 2 UNITS HORIZONTAL (50% SLOPE) UNLESS THE PERMITTEE FURNISHES A SOILS ENGINEERING OR AN ENGINEERING GEOLOGY REPORT, OR BOTH, STATING THAT THE SITE HAS BEEN INVESTIGATED AND GIVING AN OPINION THAT A CUT AT A STEEPER SLOPE WILL BE STABLE AND NOT CREATE A HAZARD TO PROPERTY OR THE ENVIRONMENT.
 - B. FILL SLOPE AND PREPARATION
 - (1) PREPARATION OF GROUND. THE GROUND SURFACE SHALL BE PREPARED TO RECEIVE FILL BY REMOVING VEGETATION, NON-COMPLYING FILL, TOPSOIL AND OTHER UNSUITABLE MATERIALS SCARIFYING TO PROVIDE A BOND WITH THE NEW FILL.
 - (2) FILL MATERIAL. AMOUNT OF ORGANIC MATERIAL DETRIMENTAL TO STRUCTURAL INTEGRITY SHALL NOT BE PERMITTED IN FILLS. EXCEPT AS PERMITTED BY THE BUILDING OFFICIAL, NO ROCK OR SIMILAR IRREDUCIBLE MATERIAL WITH A MAXIMUM DIMENSION GREATER THAN 12 INCHES (0.31 M) SHALL BE BURIED OR PLACED IN FILLS.
 - (3) EXCEPTION. THE BUILDING OFFICIAL MAY PERMIT PLACEMENT OF LARGER ROCK WHEN THE SOILS ENGINEER PROPERLY DEVISES A METHOD OF PLACEMENT, AND CONTINUOUSLY INSPECTS ITS PLACEMENT AND APPROVES THE FILL STABILITY. THE FOLLOWING CONDITIONS SHALL ALSO APPLY:
 - (a) PRIOR TO ISSUANCE OF THE GRADING PERMIT, POTENTIAL ROCK DISPOSAL AREAS SHALL BE SHOWN ON THE GRADING PLAN.
 - (b) ROCK SIZES GREATER THAN 12 INCHES (0.31 M) IN MAXIMUM DIMENSION SHALL BE 10 FEET (3.05 M) OR MORE BELOW GRADE, MEASURED VERTICALLY.
 - (c) ROCKS SHALL BE PLACED SO AS TO ASSURE FILLING OF ALL VOIDS WITH WELL-GRADED SOIL.
 - (4) COMPACTION. ALL FILLS SHALL BE COMPACTED TO A MINIMUM OF 90 PERCENT OF MAXIMUM DRY DENSITY WITH SUFFICIENT TESTING FOR DOCUMENTATION OF COMPLIANCE WITH THIS STANDARD.
 - (5) SLOPE. THE SLOPE OF FILL SURFACES SHALL BE NO STEEPER THAN IS SAFE FOR THE INTENDED USE. FILL SLOPES SHALL BE NO STEEPER THAN 1 UNIT VERTICAL IN 2 UNITS HORIZONTAL (50% SLOPE).
- 2. SETBACKS
 - a. GENERAL. CUT AND FILL SLOPES SHALL BE SET BACK FROM SITE BOUNDARIES IN ACCORDANCE WITH THIS SECTION. SETBACK DIMENSIONS SHALL BE HORIZONTAL DISTANCES MEASURED PERPENDICULAR TO THE SITE BOUNDARY.
 - b. TOP OF CUT SLOPE. THE TOP OF CUT SLOPES SHALL NOT BE MADE NEARER TO A SITE BOUNDARY LINE THAN A MINIMUM OF 2 FEET. THE SETBACK MAY NEED TO BE INCREASED FOR ANY REQUIRED INTERCEPTOR DRAINS.
 - c. TOE OF FILL SLOPE. THE TOE OF FILL SLOPE SHALL BE MADE NOT NEARER TO THE SITE BOUNDARY LINE THAN MINIMUM OF 2 FEET. WHERE A FILL SLOPE IS TO BE LOCATED NEAR THE SITE BOUNDARY AND THE ADJACENT OFFSITE PROPERTY IS DEVELOPED, SPECIAL PRECAUTIONS SHALL BE INCORPORATED IN THE WORK AS THE BUILDING OFFICIAL DEEMS NECESSARY TO PROTECT THE ADJOINING PROPERTY FROM DAMAGE AS A RESULT OF SUCH GRADING. THESE PRECAUTIONS MAY INCLUDE BUT ARE NOT LIMITED TO:
 - (1) ADDITIONAL SETBACKS.
 - (2) PROVISION FOR RETAINING, OR SLOUGH WALLS.
 - (3) MECHANICAL OR CHEMICAL TREATMENT OF THE FILL SLOPE SURFACE TO MINIMIZE EROSION.
 - (4) PROVISIONS FOR THE CONTROL OF SURFACE WATERS.
 - e. MODIFICATION OF SETBACKS. THE BUILDING OFFICIAL MAY APPROVE ALTERNATE SETBACKS. THE BUILDING OFFICIAL MAY REQUIRE AN INVESTIGATION AND RECOMMENDATION BY A QUALIFIED ENGINEER OR ENGINEERING GEOLOGIST TO DEMONSTRATE THAT THE INTENT OF THIS SECTION HAS BEEN SATISFIED.
- 3. MAINTENANCE REQUIRED. THE PROPERTY OWNER SHALL BE RESPONSIBLE FOR ADEQUATELY MAINTAINING ALL DRAINAGE FACILITIES INSTALLED PURSUANT TO THIS SECTION.
- 4. GRADING INSPECTION
 - A. GENERAL. GRADING OPERATIONS FOR WHICH A PERMIT IS REQUIRED SHALL BE SUBJECT TO INSPECTION BY THE BUILDING OFFICIAL.
 - B. PERMITTEE. THE PERMITTEE SHALL BE RESPONSIBLE FOR THE WORK TO BE PERFORMED IN ACCORDANCE WITH THE APPROVED PLANS AND SPECIFICATIONS AND IN CONFORMANCE WITH THE PROVISIONS OF THIS CODE, AND THE PERMITTEE SHALL ENGAGE CONSULTANTS, IF REQUIRED, TO PROVIDE PROFESSIONAL INSPECTIONS ON A TIMELY BASIS. THE PERMITTEE SHALL ACT AS A COORDINATOR BETWEEN THE CONSULTANTS, THE CONTRACTOR AND THE BUILDING OFFICIAL. IN THE EVENT OF CHANGED CONDITIONS, THE PERMITTEE SHALL BE RESPONSIBLE FOR INFORMING THE BUILDING OFFICIAL OF SUCH CHANGE AND SHALL PROVIDE REVISED PLANS FOR APPROVAL.
 - C. BUILDING OFFICIAL. THE BUILDING OFFICIAL SHALL INSPECT THE PROJECT AT THE VARIOUS STAGES OF WORK REQUIRING APPROVAL TO DETERMINE THAT ADEQUATE CONTROL IS BEING EXERCISED BY THE PROFESSIONAL CONSULTANTS.
 - D. NOTIFICATION OF NONCOMPLIANCE. IF, IN THE COURSE OF FULFILLING THEIR RESPECTIVE DUTIES UNDER THIS CHAPTER, THE CIVIL ENGINEER, THE SOILS ENGINEER OR THE ENGINEERING GEOLOGIST FINDS THAT THE WORK IS NOT BEING DONE IN CONFORMANCE WITH THIS CHAPTER OR THE APPROVED GRADING PLANS, THE DISCREPANCIES SHALL BE REPORTED IMMEDIATELY IN WRITING TO THE PERMITTEE AND TO THE BUILDING OFFICIAL.
 - E. TRANSFER OF RESPONSIBILITY. IF THE CIVIL ENGINEER, THE SOILS ENGINEER, OR THE ENGINEERING GEOLOGIST OF RECORD IS CHANGED DURING GRADING, THE WORK SHALL BE STOPPED UNTIL THE REPLACEMENT HAS AGREED IN WRITING TO ACCEPT THEIR RESPONSIBILITY WITHIN THE AREA OF TECHNICAL COMPETENCE FOR APPROVAL UPON COMPLETION OF THE WORK. IT SHALL BE THE DUTY OF THE PERMITTEE TO NOTIFY THE BUILDING OFFICIAL IN WRITING OF SUCH CHANGE PRIOR TO THE RE-COMMENCEMENT OF SUCH GRADING.
- 5. EROSION AND SEDIMENTATION CONTROL
 - A. ADMINISTRATION
 - (1) THE EROSION AND SEDIMENT CONTROL PROVISIONS OF THIS SECTION SHALL BE APPLICABLE TO ALL FACILITIES AND ACTIVITIES UNDER THE SUPERVISION OF THE DIRECTOR OF THE DEPARTMENT OF PUBLIC WORKS.
 - (2) THE ADMINISTRATION OF THIS SECTION, AS IT AFFECTS COUNTY FACILITIES AND ACTIVITIES, IS THE RESPONSIBILITY OF THE DIRECTOR OF THE DEPARTMENT OF PUBLIC WORKS.
 - (3) THE ADMINISTRATION OF THIS SECTION AS IT AFFECTS OTHER BUILDING, GRADING, AND RELATED ACTIVITIES IS THE RESPONSIBILITY OF THE CHIEF BUILDING OFFICIAL.
 - (4) ANY SOILS OR GEOLOGIC REPORTS PREPARED FOR ANY PROJECT WHERE A GRADING PERMIT IS SUBMITTED AS A PART OF A TENTATIVE SUBDIVISION MAP APPLICATION, OR RELATED ENVIRONMENTAL DOCUMENT, SHALL BE PLACED IN THE RECORDS OF THE CHIEF BUILDING OFFICIAL.
 - B. EROSION AND SEDIMENTATION CONTROL. THESE MINIMUM EROSION AND SEDIMENTATION CONTROL STANDARDS SHALL APPLY TO ALL PROJECTS REQUIRING BUILDING, GRADING, AND DEVELOPMENT PERMITS, AND COUNTY OF MENDOCINO PUBLIC WORKS ACTIVITIES, TO PREVENT SEDIMENTATION OR DAMAGE TO ONSITE AND OFFSITE PROPERTY. THESE STANDARDS SHALL BE INCORPORATED INTO THE PROJECT DESIGN AND SHALL BE ADHERED TO DURING PROJECT CONSTRUCTION.

- (g) PROPOSE A NEW OR MODIFIED EROSION AND SEDIMENT CONTROL TECHNIQUE IF THE TECHNIQUE IS PREFERRED AND MEETS THE INTENT OF THESE REGULATIONS. OBTAIN APPROVAL FROM THE COUNTY PRIOR TO IMPLEMENTATION.
 - (h) CONDUCT FREQUENT SITE INSPECTIONS TO ENSURE THAT CONTROL MEASURES ARE WORKING PROPERLY AND TO CORRECT PROBLEMS AS NEEDED.
 - (i) EMPLOY OTHER MEANS OF EROSION AND SEDIMENT CONTROL AS REQUIRED BY THE CHIEF BUILDING OFFICIAL OR DIRECTOR OF THE DEPARTMENT OF PUBLIC WORKS AS APPLICABLE.
- (2) SEDIMENT CONTROL
- (a) USE SEDIMENT BASINS, SILT TRAPS, OR SIMILAR MEASURE TO RETAIN SEDIMENT TRANSPORTED BY RUNOFF WATER ONSITE.
 - (b) COLLECT AND DIRECT SURFACE RUNOFF AT NON-EROSIVE VELOCITIES TO THE COMMON NATURAL WATERCOURSE OF THE DRAINAGE AREA.
 - (c) AVOID CONCENTRATING SURFACE WATER ANYWHERE EXCEPT SWALES OR WATERCOURSES.
 - (d) PREVENT MUD FROM BEING TRACKED ONTO THE PUBLIC ROADWAY BY TRAVELING OVER A TEMPORARY GRAVEL CONSTRUCTION ENTRANCE OR WASHING OFF VEHICLE TIRES BEFORE ENTERING A PUBLIC OR PRIVATE DRIVEWAY.
- (3) SLOPE CONSTRUCTION
- (a) MINIMIZE LENGTH AND STEEPNESS OF SLOPES BY BENCHING, TERRACING OR CONSTRUCTING DIVERSION STRUCTURES.
 - (b) PRESERVE, MATCH, OR BLEND CUTS AND FILLS WITH THE NATURAL CONTOURS AND UNDULATIONS OF THE LAND.
 - (c) ROUND SHARP ANGLES AT THE TOP AND SIDES OF CUT AND FILL SLOPES.
 - (d) MAINTAIN CUT AND FILL SLOPES AT LESS THAN TWO-TO-ONE (2:1, RUN:RISE) SLOPE UNLESS A GEOLOGICAL AND ENGINEERING ANALYSIS INDICATES THAT STEEPER SLOPES ARE SAFE AND EROSION AND SEDIMENT CONTROL MEASURES CAN SUCCESSFULLY PREVENT EROSION.
- (4) PROTECTION OF WATERCOURSES AND DRAINAGE INLETS
- (a) PREPARE DRAINAGEWAYS TO HANDLE CONCENTRATED OR INCREASED RUNOFF FROM DISTURBED AREAS BY USING APPROPRIATE LINING MATERIALS OR ENERGY ABSORBING DEVICES TO REDUCE THE VELOCITY OF RUNOFF WATER.
 - (b) TRAP SEDIMENT-LADEN RUNOFF IN BASINS TO ALLOW SOIL PARTICLES TO SETTLE OUT BEFORE FLOWS ARE RELEASED TO RECEIVING WATERS, STORM DRAINS, STREETS OR ADJACENT PROPERTY. THIS STANDARD IS NOT MANDATORY FOR GRADING THE SITE IS FULLY WINTERIZED AND STABILIZED PRIOR TO AND WHEN CONDUCTED BETWEEN APRIL 15 AND OCTOBER 15. REMOVE TRAPPED SEDIMENT TO A SUITABLE LOCATION ON-SITE OR AT A DISPOSAL SITE APPROVED BY THE COUNTY.
 - (c) DO NOT GRADE OR DRIVE EQUIPMENT IN A STREAMSIDE MANAGEMENT OR OTHER WET AREAS EXCEPT AS ALLOWED THROUGH THE COUNTY STREAMSIDE MANAGEMENT AREA ORDINANCE.
 - (d) DEPOSIT OR STORE EXCAVATED MATERIALS AWAY FROM WATERCOURSES.
 - (e) PROTECT ALL EXISTING OR NEWLY INSTALLED STORM DRAINAGE STRUCTURES FROM SEDIMENT CLOGGING.
 - (f) USE STRAW BALES, FILTER FABRIC WRAPS AND DRAINAGE INLET PROTECTIONS IN A MANNER THAT DOES NOT CAUSE ADDITIONAL EROSION OR FLOODING OF A ROADWAY.
- (5) DISPOSAL OF EXCAVATED MATERIALS
- (a) STOCKPILE TOPSOIL ON THE SITE FOR USE ON AREAS TO BE REVEGETATED.
 - (b) PLACE STOCKPILED SOIL IN LOCATIONS, SO THAT IF EROSION OCCURS, IT WILL NOT CONTRIBUTE TO OFFSITE SEDIMENT DISCHARGE.
 - (c) PROTECT STOCKPILED SOIL PROMPTLY THROUGH THE USE OF APPROPRIATE BMPs TO REDUCE THE RISK OF EROSION AND SEDIMENT TRANSPORT. APPLY MULCH OR OTHER PROTECTIVE COVERINGS ON STOCKPILED MATERIAL THAT WILL BE EXPOSED THROUGH THE WINTER SEASON.
 - (d) DISPOSE OF EXCAVATED MATERIAL NOT USED AT THE SITE AT A LOCATION APPROVED BY THE COUNTY.
- (6) DUST CONTROL
- (a) ALL CONSTRUCTION AREAS, INCLUDING DISPOSAL SITES, SHALL BE TREATED AND MAINTAINED AS NECESSARY TO MINIMIZE THE EMISSION OF DUST. MAINTENANCE SHALL BE CONDUCTED AS NECESSARY TO PREVENT A NUISANCE TO OFFSITE PROPERTIES.
 - (b) ALL CONSTRUCTION SITES, INCLUDING DRIVEWAYS, SHALL BE MAINTAINED AS NECESSARY TO MINIMIZE THE EMISSION OF DUST AND PREVENT THE CREATION OF A NUISANCE TO ADJACENT PROPERTIES.
- (7) REVEGETATION
- (a) APPLY TEMPORARY SEEDING AND MULCHING TO DENUDED AREAS PRIOR TO OCTOBER 15 UNLESS THE PROJECT IS CONDITIONED OTHERWISE.
 - (b) ESTABLISH A PERMANENT VEGETATIVE COVER ON DENUDED AREAS NOT OTHERWISE STABILIZED. PERMANENT VEGETATION GROUND COVER MUST CONTROL SOIL EROSION SATISFACTORILY AND SURVIVE SEVERE WEATHER CONDITIONS.
 - (c) RETAIN A VEGETATIVE BARRIER WHENEVER POSSIBLE AROUND PROPERTY BOUNDARIES.
 - (d) USE SELF-SUSTAINING, NON-INVASIVE PLANTS THAT REQUIRE LITTLE OR NO MAINTENANCE AND DO NOT CREATE AN EXTREME FIRE HAZARD.
 - (e) USE NATIVE PLANT SPECIES WHENEVER FEASIBLE.

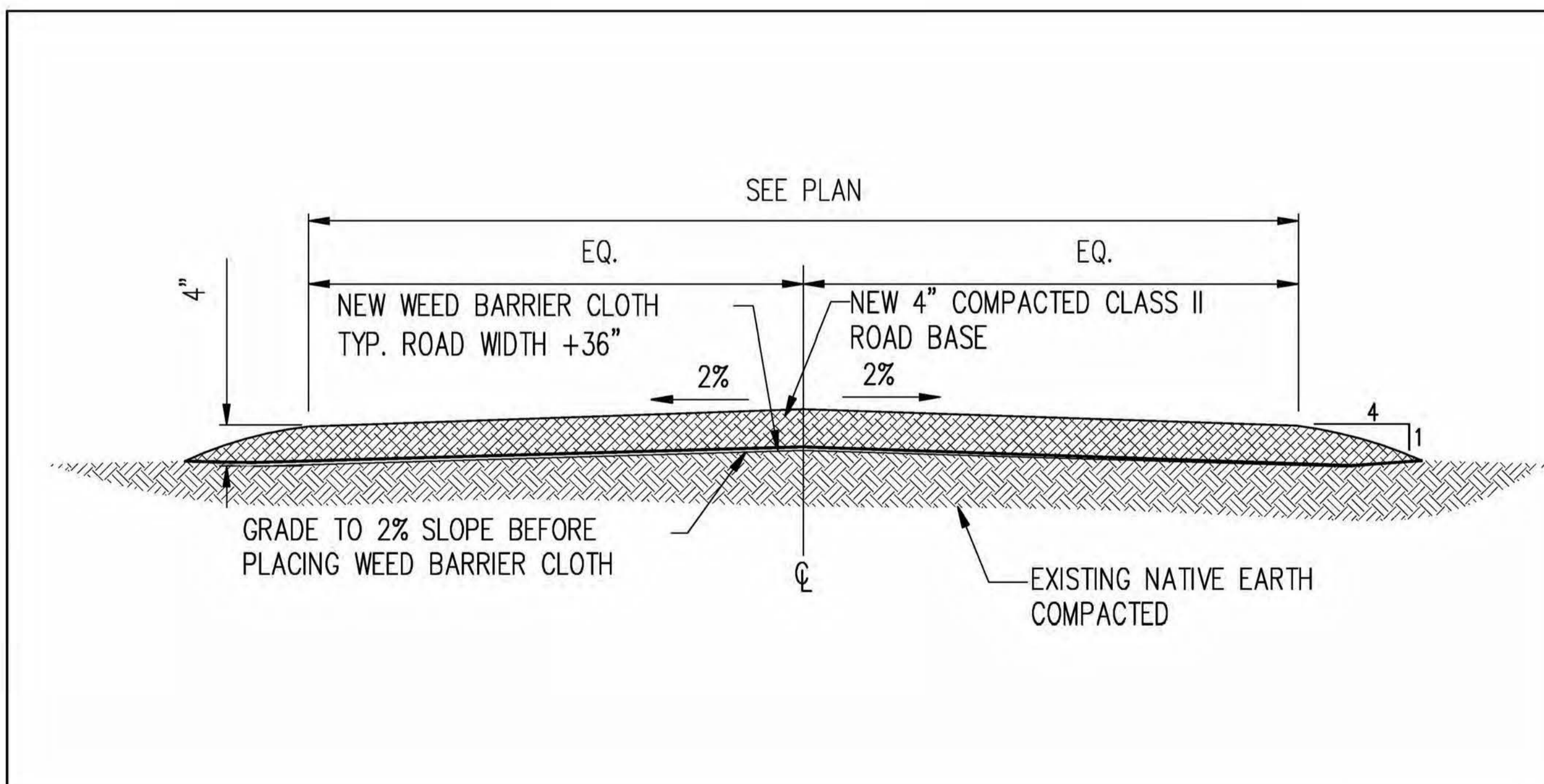

TYP. GRAVEL ROAD SECTION SCALE: N.T.S. 1

PROPRIETARY INFORMATION THE INFORMATION CONTAINED IN THIS SET OF DRAWINGS IS PROPRIETARY BY NATURE. ANY USE OR DISCLOSURE OTHER THAN THAT WHICH RELATES TO PEEK SITE-COM IS STRICTLY PROHIBITED

CLIENT: at&t 2600 CAMINO RAMON SAN RAMON, CA 94583

PROJECT INFORMATION:			
GOLD HILL			
6812 GODS WAY LOTUS, CA 95651			
REV:	DATE:	DESCRIPTION:	BY:
1	6-5-17	90% ZONING DOCUMENTS	AMP
1	8-3-17	95% ZONING DOCUMENTS	ALP
2	8-9-17	100% ZONING DOCUMENTS	ALP

COORDINATING ENGINEER: Peek Site-Com 12852 Earhart Ave. Suite 101 Auburn, California 95602 Phone (530) 885-6160 E-Mail info@peeksitcom.com

SEAL: REGISTERED PROFESSIONAL ENGINEER CHRIS OLIVEIRA NO. C 33407 EXP. 08/29/18 CIVIL STATE OF CALIFORNIA

SHEET #: CVL03054 CHK.: ... DRAWN BY: AMP SHEET TITLE: GRADING NOTES & DETAILS SHEET NUMBER: C-3 REVISION: 0

PROPRIETARY INFORMATION
 THE INFORMATION CONTAINED IN THIS SET OF DRAWINGS IS PROPRIETARY BY NATURE. ANY USE OR DISCLOSURE OTHER THAN THAT WHICH RELATES TO PEEK SITE-COM IS STRICTLY PROHIBITED

CLIENT:



2600 CAMINO RAMON
 SAN RAMON, CA 94583

PROJECT INFORMATION:

GOLD HILL

6812 GODS WAY
 LOTUS, CA 95651

REV: DATE: DESCRIPTION: BY:

REV:	DATE:	DESCRIPTION:	BY:
1	6-5-17	90% ZONING DOCUMENTS	AMP
1	8-3-17	95% ZONING DOCUMENTS	ALP
2	8-9-17	100% ZONING DOCUMENTS	ALP

COORDINATING ENGINEER:

Peek Site-Com

12852 Earhart Ave. Suite 101
 Auburn, California 95602
 Phone (530) 885-6160

E-Mail info@peeksitecom.com

SEAL:



SITE #: CHK.: DRAWN BY:

CVL03054 ... AMP

SHEET TITLE:

GRADING PLAN

SHEET NUMBER: REVISION:

C-4 0

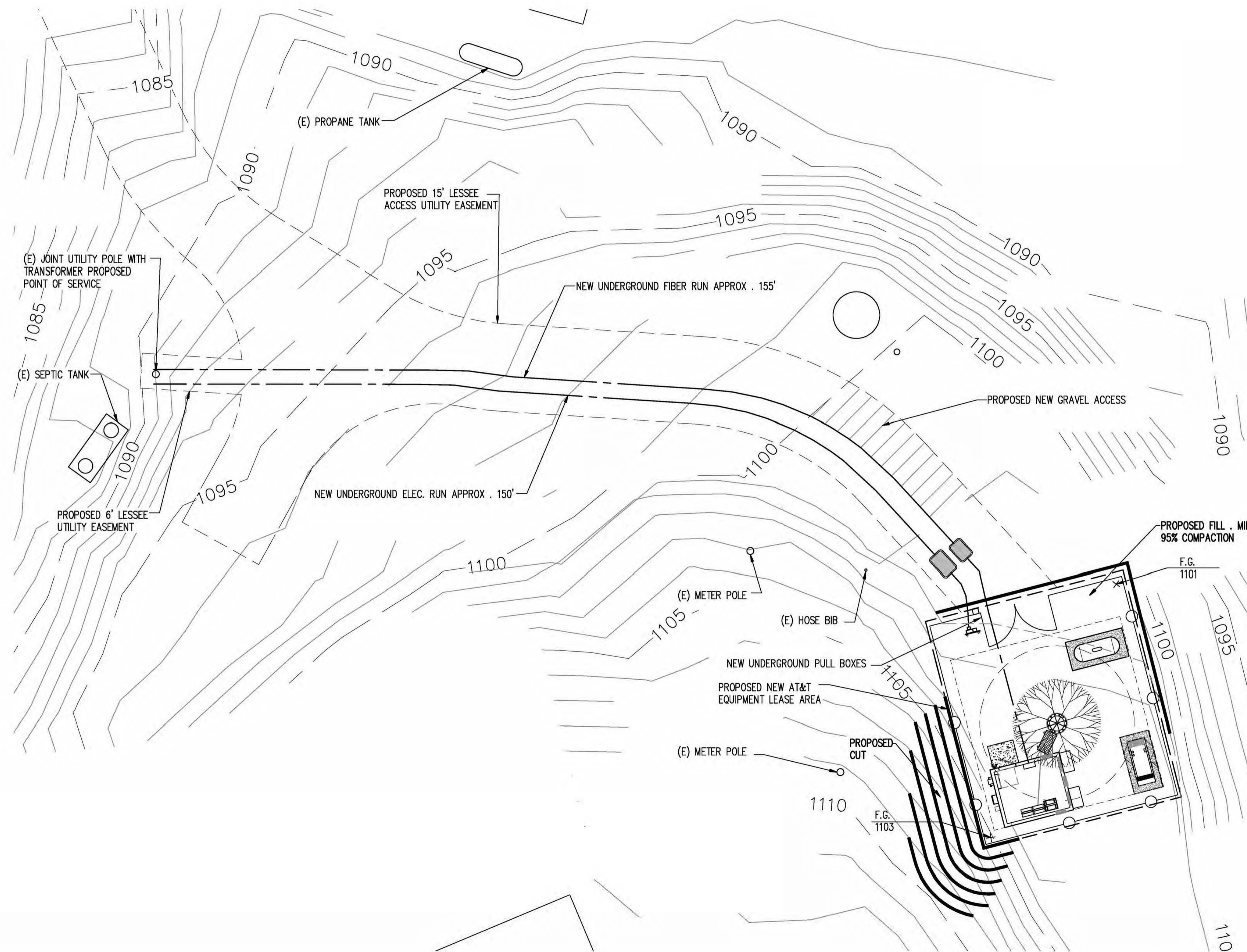

PRELIMINARY GRADING PLAN

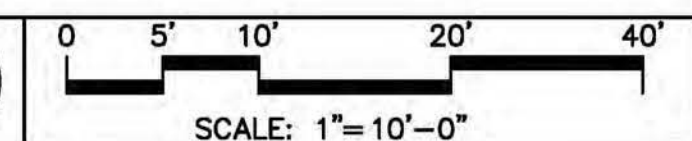

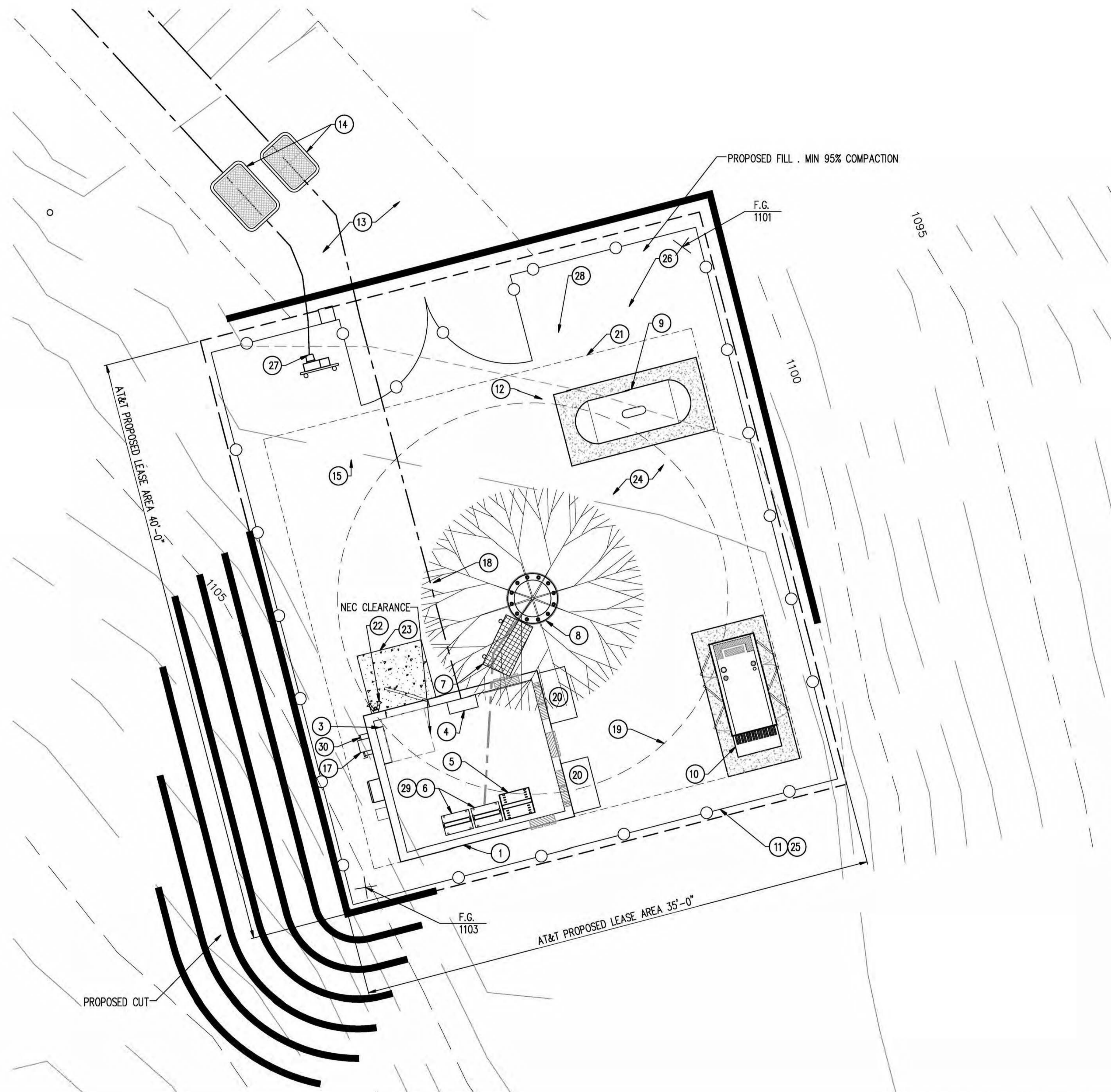

KEY NOTES

1. NEW 10' x 12' LIGHTWEIGHT PRE-FAB EQUIPMENT SHELTER
2. (1) NEW GPS ANTENNA
3. NEW ELEC. PANEL,
4. TELCO BOX,
5. NEW D/C POWER PLANT
6. NEW 23" FIF RACK, TYP. OF (2)
7. NEW HEAVY ICE BRIDGE
8. NEW MONOPIPE
9. NEW 500 GAL LP PROPANE TANK ON NEW 5' x 10' CONC. SLAB
10. NEW 35KW BACK-UP GENERATOR ON NEW CONC. SLAB
11. NEW 6'-0" CHAIN LINK FENCE W/ VINYL SLATS
12. NEW 12' WIDE DOUBLE ACCESS GATE
13. NEW A/C GRAVEL ROAD
14. NEW U/G POWER AND TELCO CONDUITS
15. NEW METER
16. N/A
17. NEW UTILITY RACK
18. NEW 2A:20BC RATED FIRE EXTINGUISHER IN WEATHER RESISTANT CABINET
19. 24' MAX BRANCH DIAMETER AT BASE OF POLE
20. NEW HVAC
21. OUTLINE OF NEW TOWER MAT FOUNDATION
22. NEW OUTDOOR LIGHTS PROVIDED WITH SHELTER, W/ TIMER AND MOTION SENSOR
23. NEW CONC. STOOP
24. NEW MIN. 2" OF 3/4" CLEAN CRUSHED ROCK OVER WEED BARRIER FABRIC COVERING ENTIRE LEASE AREA
25. NEW SOUND BLANKET BBC-13X, 1.2 LBS. PSF MIN. OR EQUAL SOUND BLANKET AT INTERIOR SIDE OF FENCE
26. NEW AT&T 35'X35' LEASE AREA
27. NEW FIRE DEPT. KNOX BOX
28. NEW CARRIER CONTACT SIGNAGE AT GATE
29. NEW CIENA WITHIN FIF RACK
30. NEW 200 DISCONNECT

EQUIPMENT PLAN 1

PROPRIETARY INFORMATION
 THE INFORMATION CONTAINED IN THIS SET OF DRAWINGS IS PROPRIETARY BY NATURE. ANY USE OR DISCLOSURE OTHER THAN THAT WHICH RELATES TO PEEK SITE-COM IS STRICTLY PROHIBITED

CLIENT:



2600 CAMINO RAMON
 SAN RAMON, CA 94583

PROJECT INFORMATION:

GOLD HILL
 6812 GODS WAY
 LOTUS, CA 95651

REV: DATE: DESCRIPTION: BY:

REV	DATE	DESCRIPTION	BY
1	6-5-17	90% ZONING DOCUMENTS	AMP
1	8-3-17	95% ZONING DOCUMENTS	ALP
2	8-9-17	100% ZONING DOCUMENTS	ALP

COORDINATING ENGINEER:

Peek Site-Com
 12852 Earhart Ave. Suite 101
 Auburn, California 95602
 Phone (530) 885-6160
 E-Mail info@peeksitecom.com

SEAL:



SITE #: _____ CHK.: _____ DRAWN BY: _____

CVL03054 ... AMP

SHEET TITLE:

EQUIPMENT PLAN

SHEET NUMBER: _____ REVISION: _____

A-2 0

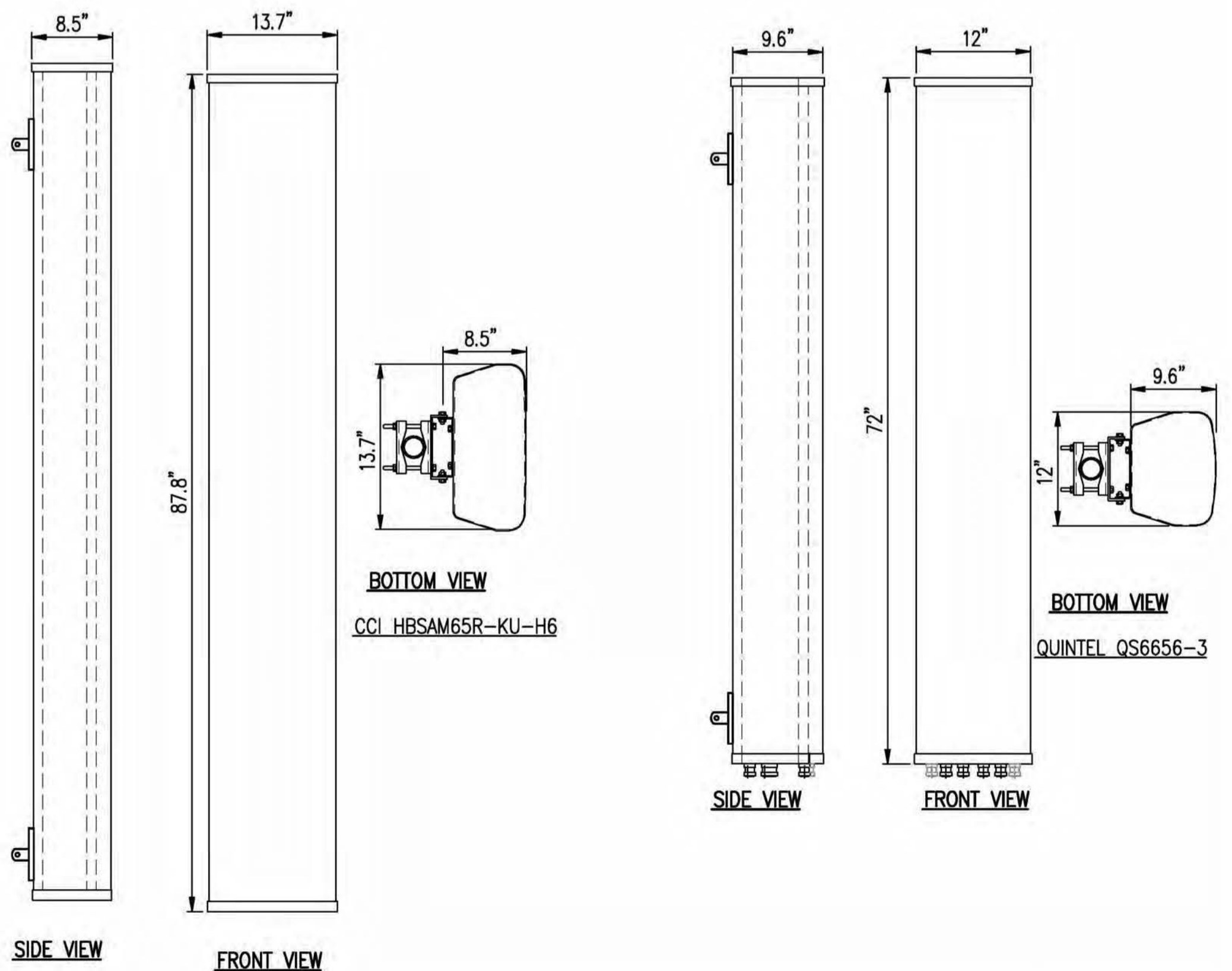

ANTENNA DETAIL

SCALE: N.T.S. 5

RF SCHEDULE

SECTOR/POS.	ANTENNA MODEL	RAD CENTER	PHYSICAL AZIMUTH	RRU	TMA	FIBER LENGTH	COAX LENGTH	COAX DIA.	NO.
A/1	QS6656-3	± 110'	90°	(1) RRUS-11 & (1) RRUS-32 B2	N/A	± 150'	± N/A	N/A	-
A/2	QS6656-3	± 110'	90°	(1) RRUS-11	N/A	± 150'	± N/A	N/A	-
A/3	HBSAM65R-KU-H6	± 100'	90°	(1) RRUS-11 & (1) RRUS-32 B66	N/A	± 150'	± N/A	N/A	-
A/4	HBSAM65R-KU-H6	± 100'	90°	(1) RRUS-32 B30	N/A	± 150'	± N/A	N/A	-
B/1	QS6656-3	± 110'	330°	(1) RRUS-11 & (1) RRUS-32 B2	N/A	± 150'	± N/A	N/A	-
B/2	QS6656-3	± 110'	330°	(1) RRUS-11	N/A	± 150'	± N/A	N/A	-
B/3	HBSAM65R-KU-H6	± 100'	330°	(1) RRUS-11 & (1) RRUS-32 B66	N/A	± 150'	± N/A	N/A	-
B/4	HBSAM65R-KU-H6	± 100'	330°	(1) RRUS-32 B30	N/A	± 150'	± N/A	N/A	-
C/1	QS6656-3	± 110'	210°	(1) RRUS-11 & (1) RRUS-32 B2	N/A	± 150'	± N/A	N/A	-
C/2	QS6656-3	± 110'	210°	(1) RRUS-11	N/A	± 150'	± N/A	N/A	-
C/3	HBSAM65R-KU-H6	± 100'	210°	(1) RRUS-11 & (1) RRUS-32 B66	N/A	± 150'	± N/A	N/A	-
C/4	HBSAM65R-KU-H6	± 100'	210°	(1) RRUS-32 B30	N/A	± 150'	± N/A	N/A	-

RF SCHEDULE

SCALE: N.T.S. 1

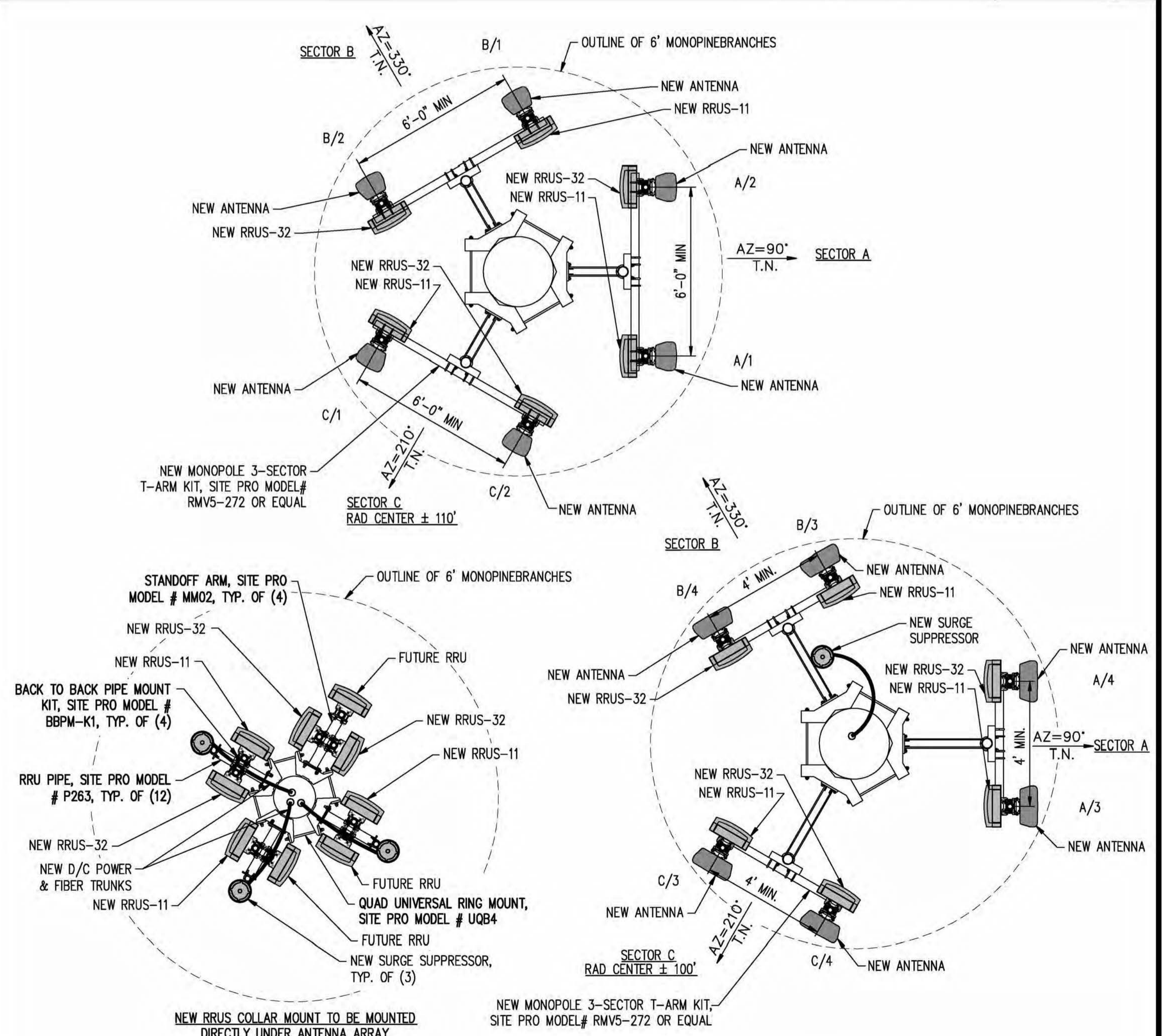

ANTENNA PLAN

SCALE: 3/8"=1'-0" 2

PROPRIETARY INFORMATION
THE INFORMATION CONTAINED IN THIS SET OF DRAWINGS IS PROPRIETARY BY NATURE. ANY USE OR DISCLOSURE OTHER THAN THAT WHICH RELATES TO PEEK SITE-COM IS STRICTLY PROHIBITED



2600 CAMINO RAMON
SAN RAMON, CA 94583

PROJECT INFORMATION:

GOLD HILL

6812 GODS WAY
LOTUS, CA 95651

REV.	DATE	DESCRIPTION	BY
1	6-5-17	90% ZONING DOCUMENTS	AMP
1	8-3-17	95% ZONING DOCUMENTS	ALP
2	8-9-17	100% ZONING DOCUMENTS	ALP

COORDINATING ENGINEER:

Peek Site-Com
12852 Earhart Ave. Suite 101
Auburn, California 95602
Phone (530) 885-6160
E-Mail info@peeksitecom.com



SITE #: CVL03054
CHK.: ...
DRAWN BY: AMP

ANTENNA PLAN & DETAILS

SHEET NUMBER: A-3
REVISION: 0

PROPRIETARY INFORMATION
 THE INFORMATION CONTAINED IN THIS SET OF DRAWINGS IS PROPRIETARY BY NATURE. ANY USE OR DISCLOSURE OTHER THAN THAT WHICH RELATES TO PEEK SITE-COM IS STRICTLY PROHIBITED

CLIENT:



2600 CAMINO RAMON
 SAN RAMON, CA 94583

PROJECT INFORMATION:

GOLD HILL

6812 GODS WAY
 LOTUS, CA 95651

REV: DATE: DESCRIPTION: BY:

1	6-5-17	90% ZONING DOCUMENTS	AMP
1	8-3-17	95% ZONING DOCUMENTS	ALP
2	8-9-17	100% ZONING DOCUMENTS	ALP

COORDINATING ENGINEER:

Peek Site-Com

12852 Earhart Ave. Suite 101
 Auburn, California 95602
 Phone (530) 885-6160

E-Mail info@peeksitecom.com

SEAL:



SITE #: CHK.: DRAWN BY:

CVL03054 ... AMP

SHEET TITLE:

DETAILS

SHEET NUMBER: REVISION:

A-3.1 0

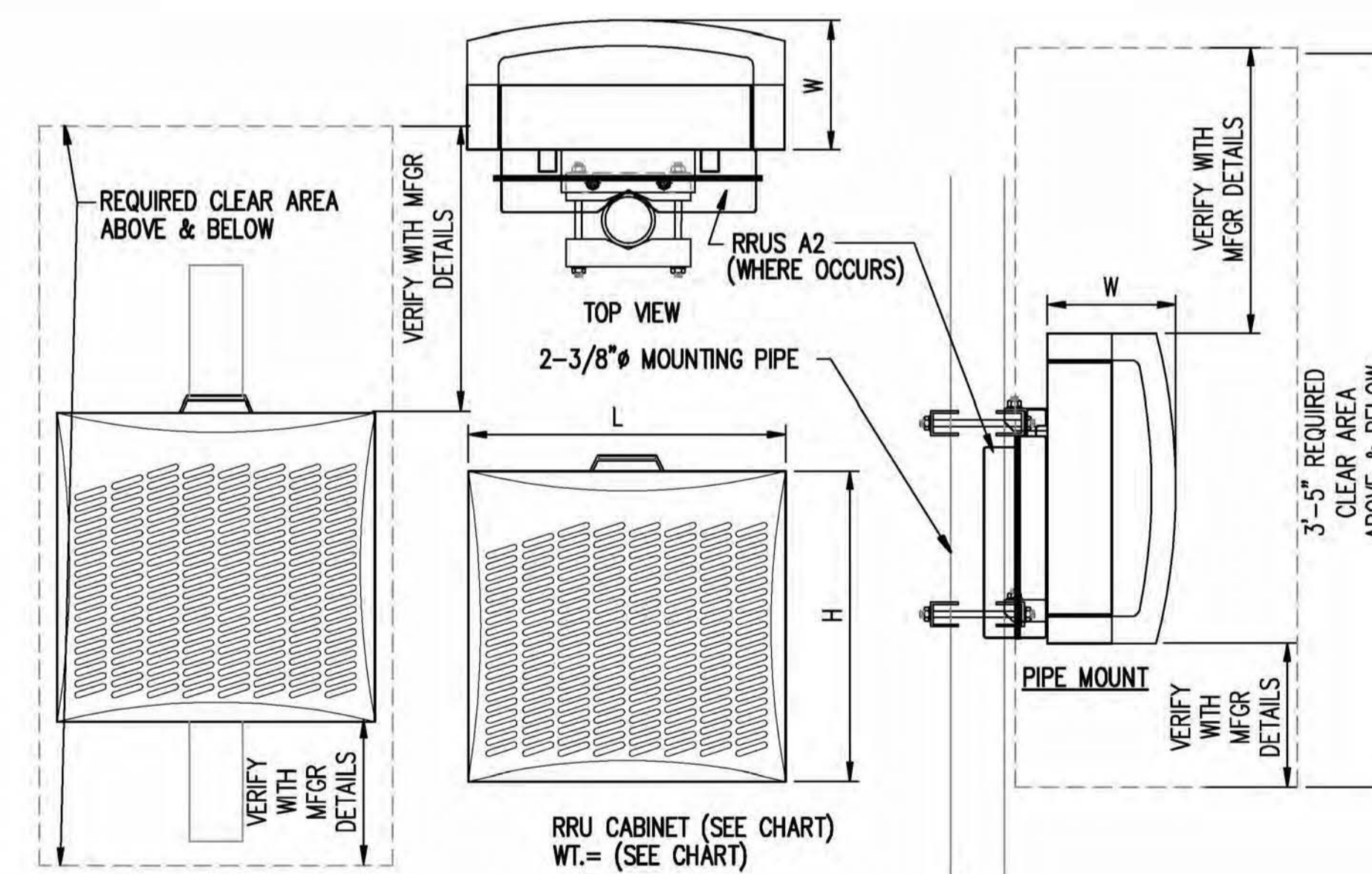
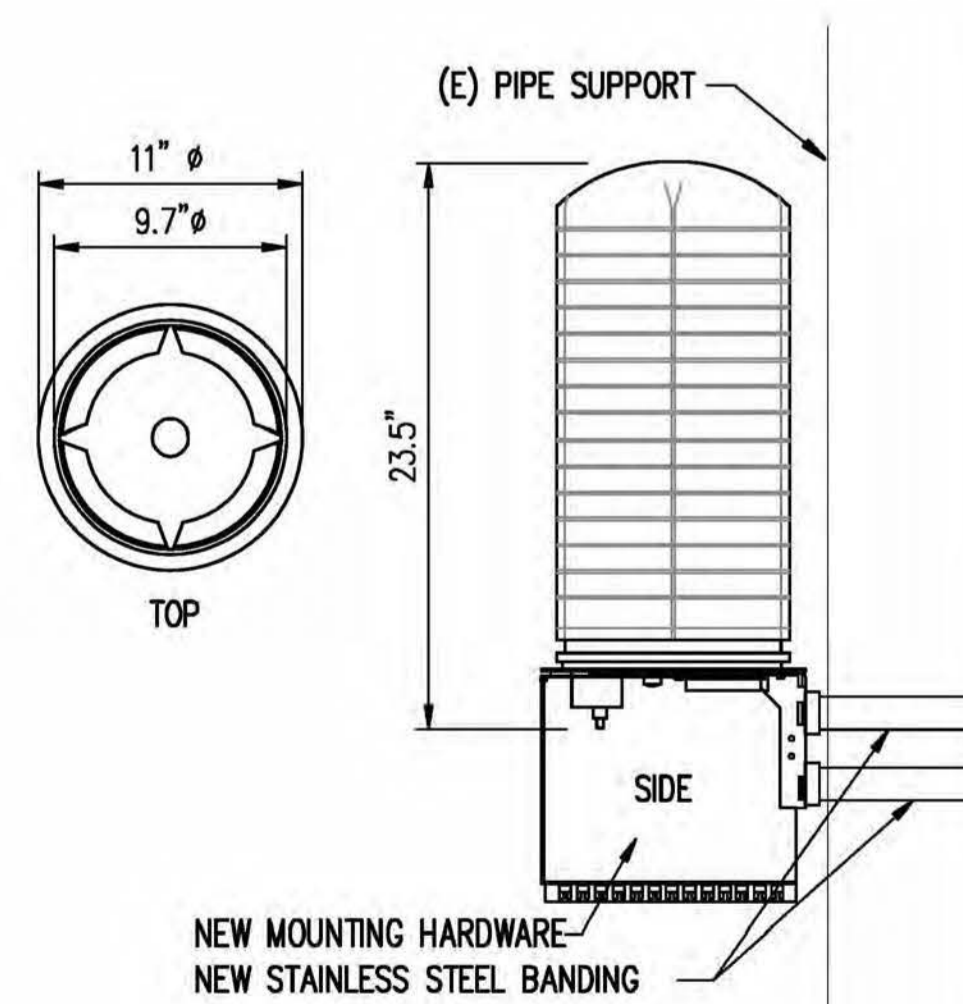

TYPE	LENGTH	HEIGHT	WIDTH	WEIGHT
RRU-11	17.8"	17.3"	7.19"	50 LBS
RRUS-E2	20.4"	18.5"	7.5"	50 LBS
RRUS-32	29.9"	13.3"	9.5"	60 LBS
RRU-12	20.4"	18.5"	7.5"	50 LBS
A2	12.8"	15"	3.5"	21 LBS

NOTE: SEE RF SHEET FOR RRU PLACEMENT

SURGE SUPP. DETAIL

SCALE: N.T.S.

3

RRU DETAIL

SCALE: N.T.S.

4

PROPRIETARY INFORMATION
 THE INFORMATION CONTAINED IN THIS SET OF DRAWINGS IS PROPRIETARY BY NATURE. ANY USE OR DISCLOSURE OTHER THAN THAT WHICH RELATES TO PEEK SITE-COM IS STRICTLY PROHIBITED

CLIENT:



2600 CAMINO RAMON
 SAN RAMON, CA 94583

PROJECT INFORMATION:

GOLD HILL

6812 GODS WAY
 LOTUS, CA 95651

REV: DATE: DESCRIPTION: BY:

1	6-5-17	90% ZONING DOCUMENTS	AMP
1	8-3-17	95% ZONING DOCUMENTS	ALP
2	8-9-17	100% ZONING DOCUMENTS	ALP

COORDINATING ENGINEER:

Peek Site-Com

12852 Earhart Ave. Suite 101
 Auburn, California 95602
 Phone (530) 885-6160
 E-Mail info@peeksitcom.com

SEAL:



SITE #: CHK.: DRAWN BY:

CVL03054 ... AMP

SHEET TITLE:

ELEVATIONS

SHEET NUMBER: REVISION:

A-4.1 0

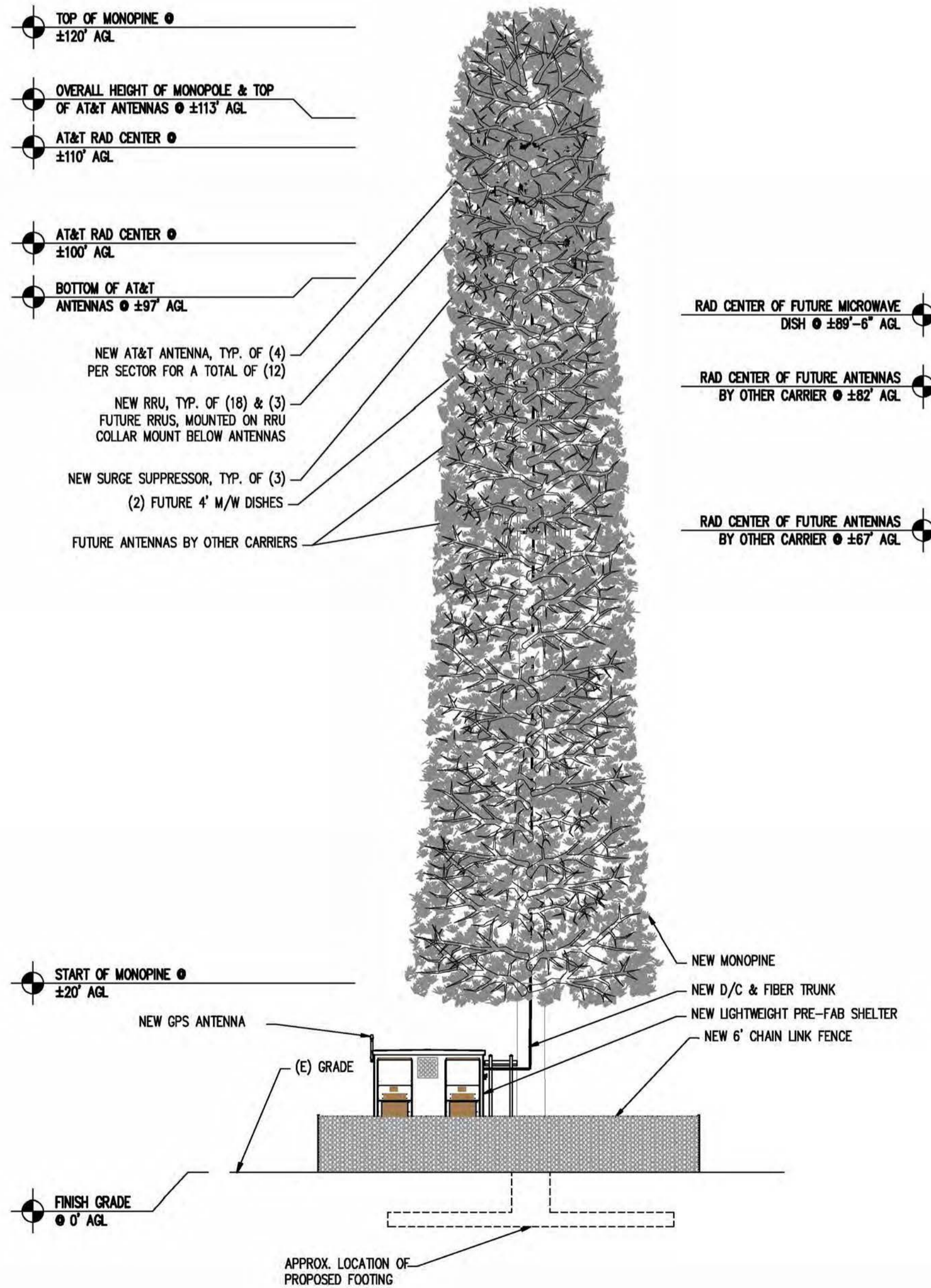

EAST ELEVATION

SCALE: 3/32"=1'-0"

2

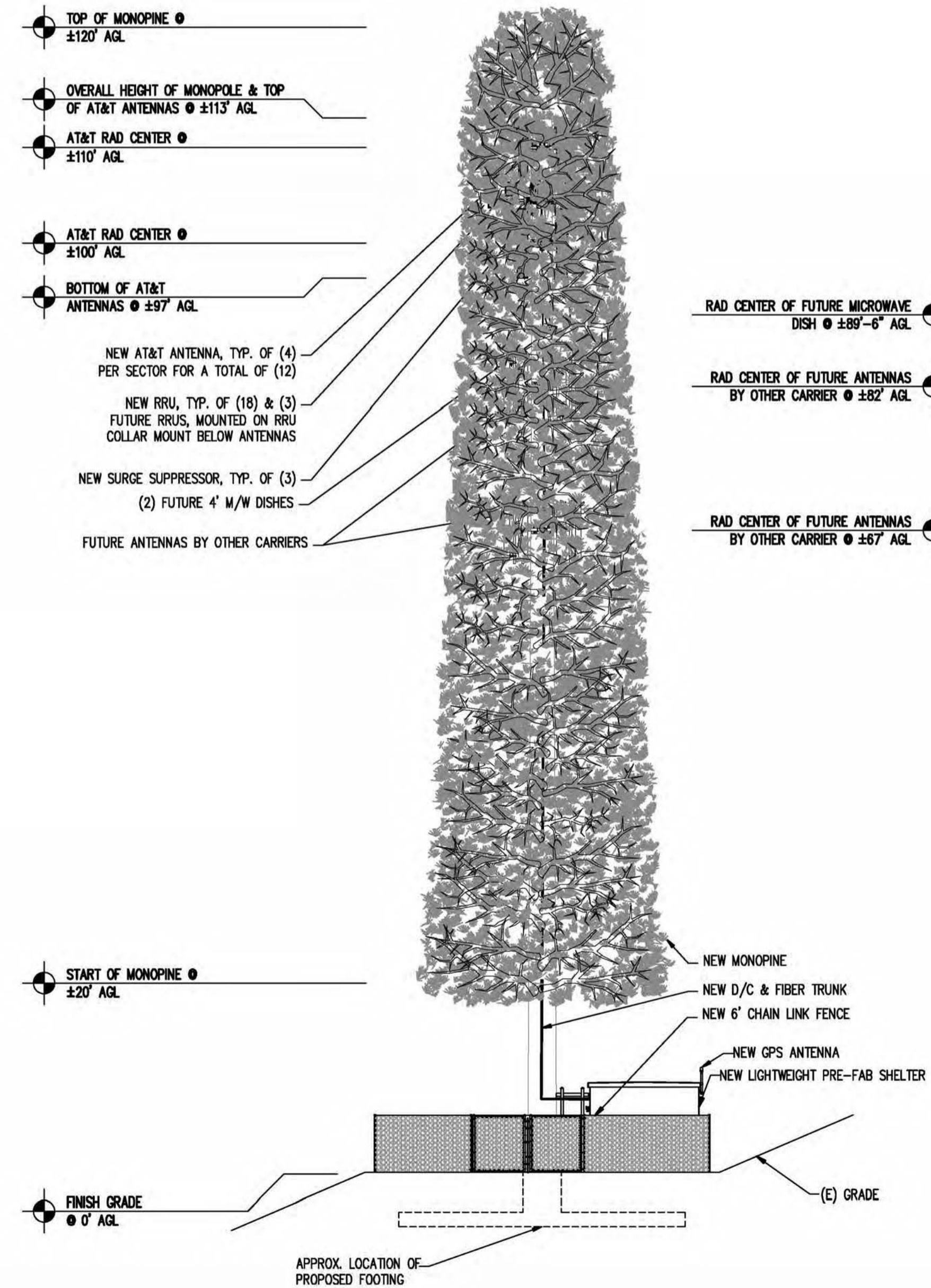

NORTH ELEVATION

SCALE: 3/32"=1'-0"

1

- NOTE:
1. MONOPOLE SHOWN ARE FOR ILLUSTRATIVE PURPOSES ONLY AND ARE NOT TO SCALE.
 2. TRUNK TO BE PAINTED KELLEY MOOR LOG CABIN BROWN OR EQUAL.
 3. ANTENNAS TO BE CONCEALED WITH ANTENNAS SOCKS
 4. RRUS TO BE PAINTED BROWN

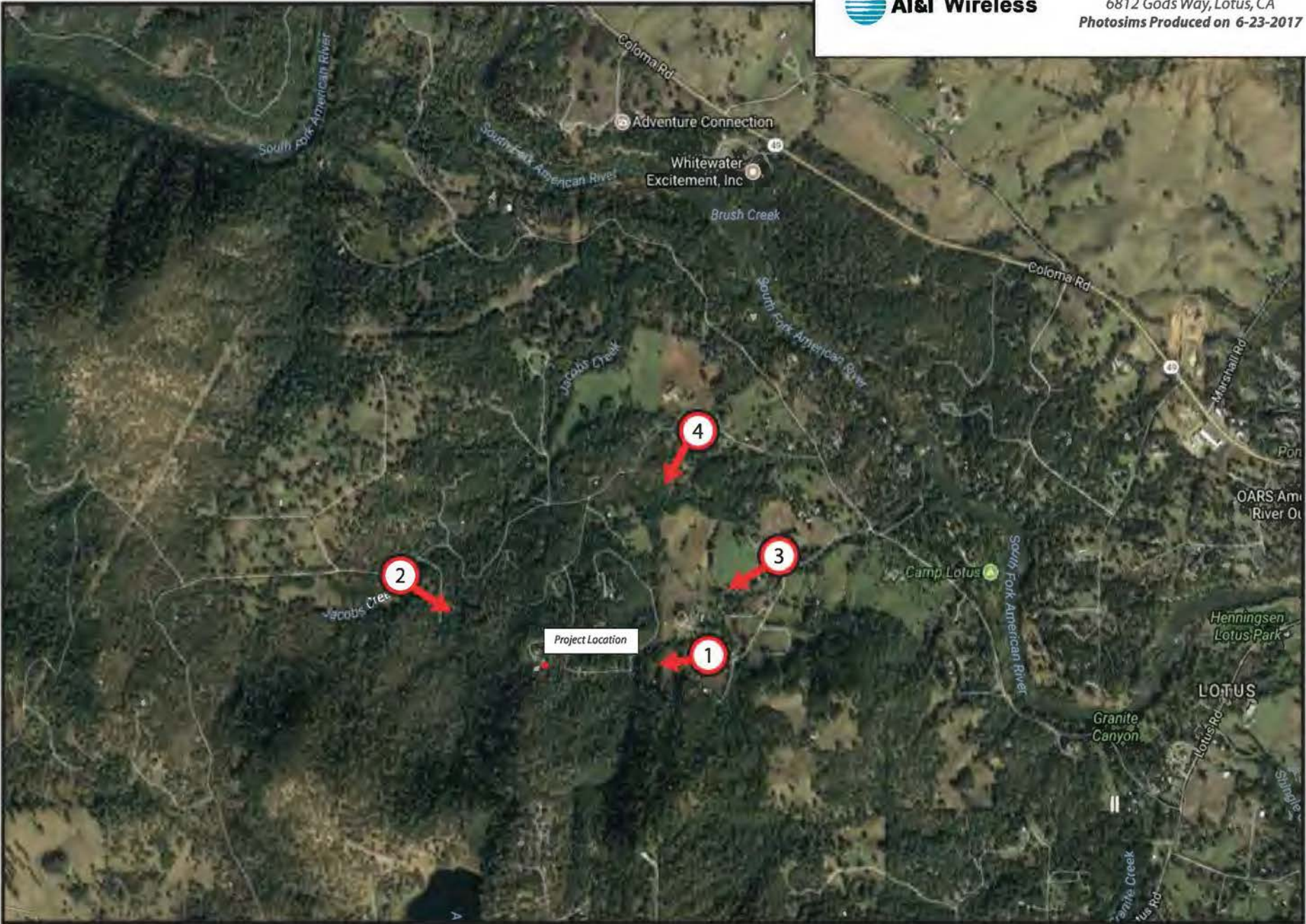

Exhibit G
Site 7 Gold Hill

Existing



Proposed



view from El Campo Road looking west at site

Existing



Proposed



view from Clark Mountain Road looking southeast at site



CVL03054 Gold Hill
6812 Gods Way, Lotus, CA

Photosims Produced on 6-23-2017



Existing



Proposed



view from Bassi Road looking southwest at site



CVL03054 Gold Hill
6812 Gods Way, Lotus, CA
Photosims Produced on 6-23-2017



Existing



Proposed



view from Clark Mountain Road looking southwest at site



CVL03054 Gold Hill
6812 Gods Way, Lotus, CA
Photosims Produced on 6-23-2017



CVL03054 Zoning Propagation Map

June 13, 2017

Exhibit H
Site 7 Gold Hill

Existing LTE 700 Coverage (RC = 108')

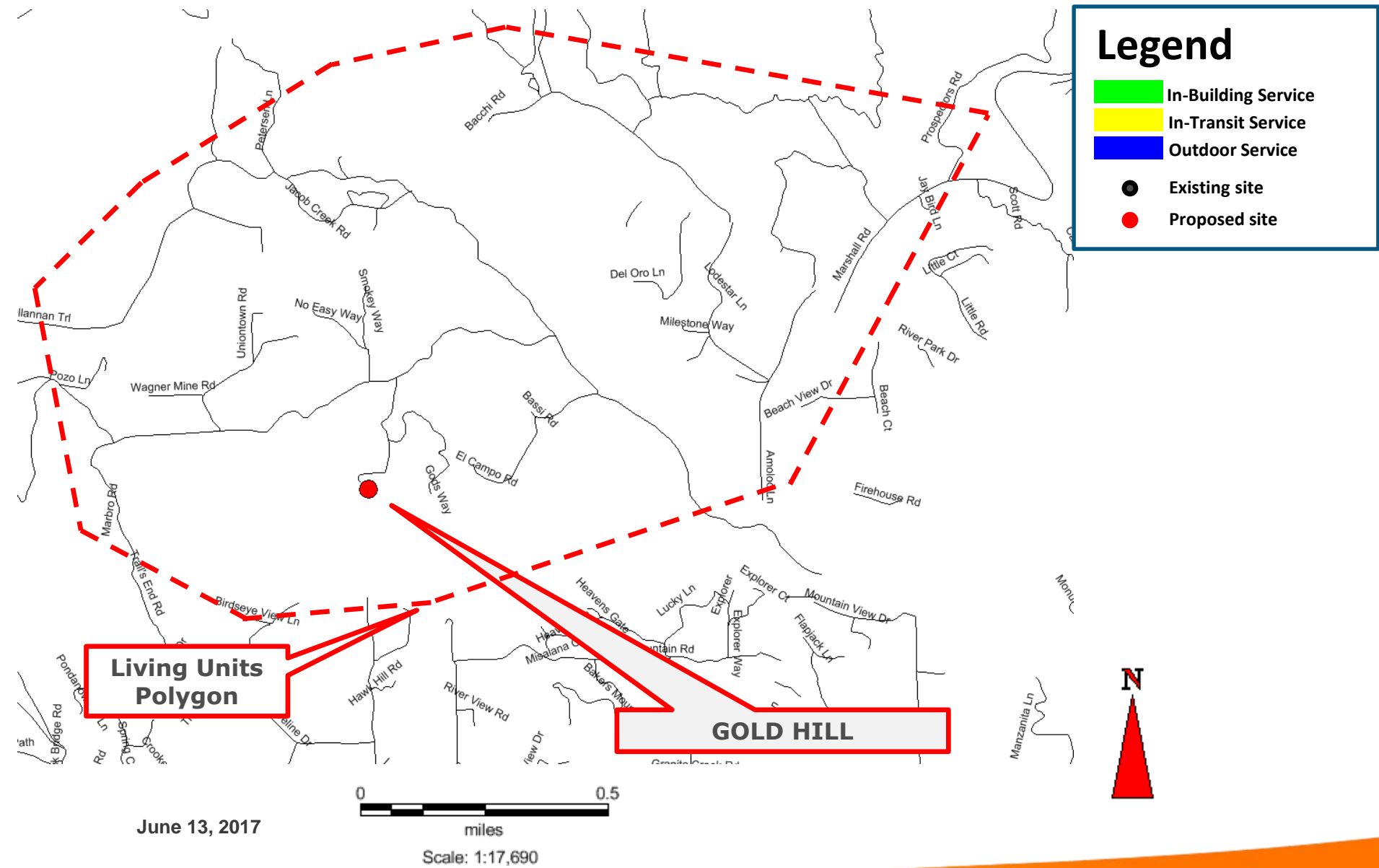

Proposed LTE 700 Coverage (RC = 108')

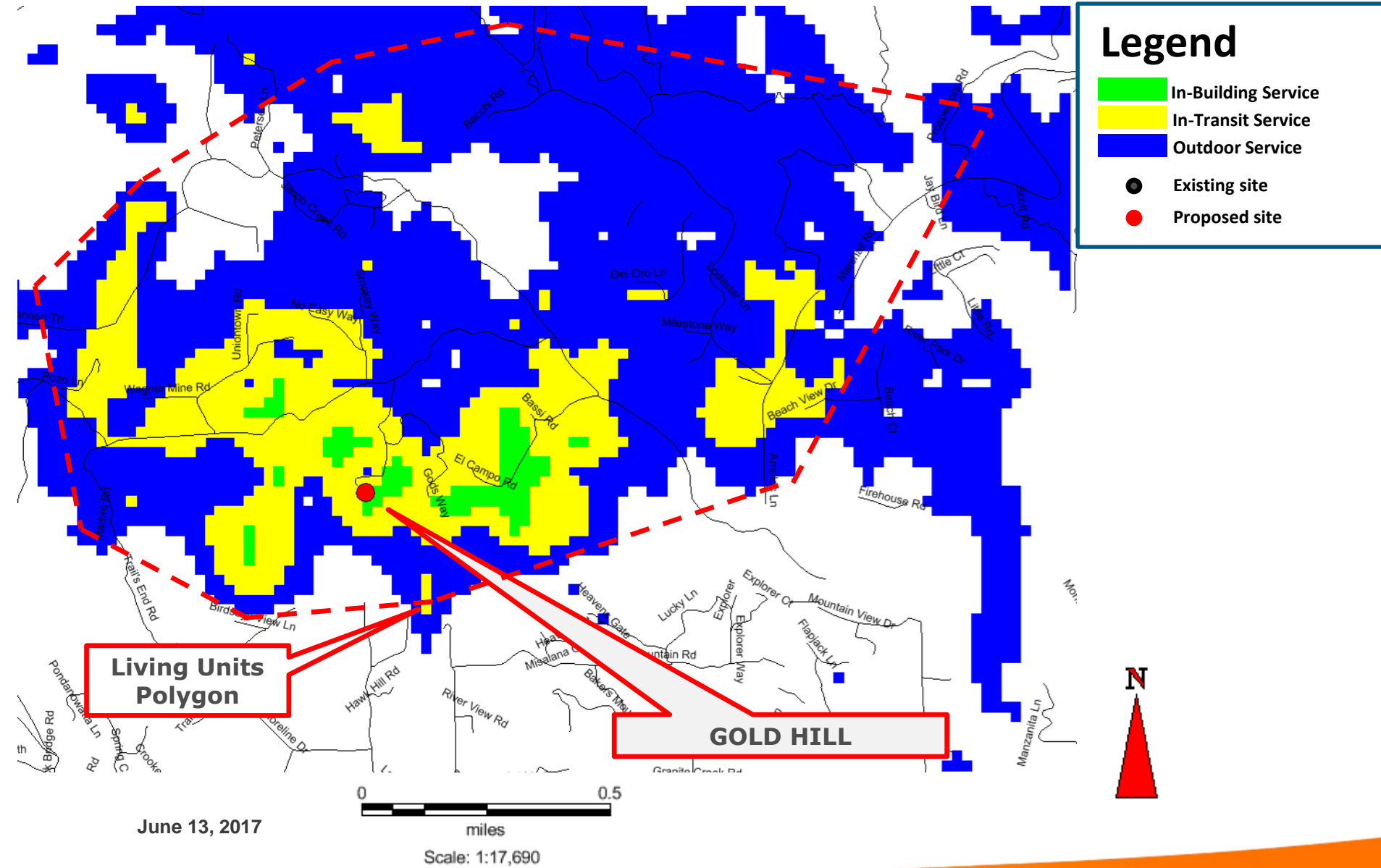



Radio Frequency Emissions Compliance Report For AT&T Mobility

Site Name: Gold Hill	Site Structure Type: Monopine
Address: 6812 Gods Way Lotus, CA	Latitude: 38.802398
Report Date: August 17, 2017	Longitude: -120.937291
	Project: New Build

General Summary

AT&T Mobility has contracted Waterford Consultants, LLC to conduct a Radio Frequency Electromagnetic Compliance assessment of the proposed Gold Hill site located at 6812 Gods Way, Lotus, CA. This report contains information about the radio telecommunications equipment to be installed at this site and the surrounding environment with regard to RF Hazard compliance. This assessment is based on installation designs and operational parameters provided by AT&T Mobility.

The compliance framework is derived from the Federal Communications Commission (FCC) Rules and Regulations for preventing human exposure in excess of the applicable Maximum Permissible Exposure ("MPE") limits. At any location at this site, the power density resulting from each transmitter may be expressed as a percentage of the frequency-specific limits and added to determine if 100% of the exposure limit has been exceeded. The FCC Rules define two tiers of permissible exposure differentiated by the situation in which the exposure takes place and/or the status of the individuals who are subject to exposure. General Population / Uncontrolled exposure limits apply to those situations in which persons may not be aware of the presence of electromagnetic energy, where exposure is not employment-related, or where persons cannot exercise control over their exposure. Occupational / Controlled exposure limits apply to situations in which persons are exposed as a consequence of their employment, have been made fully aware of the potential for exposure, and can exercise control over their exposure. Based on the criteria for these classifications, the FCC General Population limit is considered to be a level that is safe for continuous exposure time. The FCC General Population limit is 5 times more restrictive than the Occupational limits.

Frequency (MHz)	<i>Limits for General Population/ Uncontrolled Exposure</i>		<i>Limits for Occupational/ Controlled Exposure</i>	
	Power Density (mW/cm ²)	Averaging Time (minutes)	Power Density (mW/cm ²)	Averaging Time (minutes)
30-300	0.2	30	1	6
300-1500	f/1500	30	f/300	6
1500-100,000	1.0	30	5.0	6

f=Frequency (MHz)

In situations where the predicted MPE exceeds the General Population threshold in an accessible area as a result of emissions from multiple transmitters, FCC licensees that contribute greater than 5% of the aggregate MPE share responsibility for mitigation.

Exhibit I Site 7 Gold Hill

Based on the computational guidelines set forth in FCC OET Bulletin 65, Waterford Consultants, LLC has developed software to predict the overall Maximum Permissible Exposure possible at any particular location given the spatial orientation and operating parameters of multiple RF sources. These theoretical results represent worst-case predictions as emitters are assumed to be operating at 100% duty cycle.

For any area in excess of 100% General Population MPE, access controls with appropriate RF alerting signage must be put in place and maintained to restrict access to authorized personnel. Signage must be posted to be visible upon approach from any direction to provide notification of potential conditions within these areas. Subject to other site security requirements, occupational personnel should be trained in RF safety and equipped with personal protective equipment (e.g. RF personal monitor) designed for safe work in the vicinity of RF emitters. Controls such as physical barriers to entry imposed by locked doors, hatches and ladders or other access control mechanisms may be supplemented by alarms that alert the individual and notify site management of a breach in access control. Waterford Consultants, LLC recommends that any work activity in these designated areas or in front of any transmitting antennas be coordinated with all wireless tenants.

Analysis

AT&T Mobility proposes the following installation at this location:

- Install twelve (12) new panel antennas
- Install nine (9) new RRUS-11 Remote Radio Head units
- Install nine (9) new RRUS-32 Remote Radio Head units

The antennas will be mounted on a 113-foot monopole with centerlines at 100 and 110 feet above ground level. The antennas will be oriented toward 90, 330 and 210 degrees. The Effective Radiated Power (ERP) in any direction from all AT&T Mobility operations will not exceed 26,557 Watts. Other appurtenances such as GPS antennas, RRUs and hybrid cable are not sources of RF emissions. From this site, AT&T Mobility will enhance voice and data services to surrounding areas in licensed 700, 850, 1900, 2100 and 2300 MHz bands. No other antennas are known to be operating in the vicinity of this site.

Power density decreases significantly with distance from any antenna. The panel-type antennas to be employed at this site are highly directional by design and the orientation in azimuth and mounting elevation, as documented, serve to reduce the potential to exceed MPE limits at any location other than directly in front of the antennas. For accessible areas at ground level, the maximum predicted power density level resulting from all AT&T Mobility operations is 0.5265% of the FCC General Population limits (0.1053% of the FCC Occupational limits). Incident at adjacent buildings depicted in Figure 1, the maximum predicted power density level resulting from all AT&T Mobility operations is 0.6315% of the FCC General Population limits (0.1263% of the FCC Occupational limits). The proposed operation will not expose members of the General Public to hazardous levels of RF energy.

Waterford Consultants, LLC recommends posting contact information signage at the gate that informs personnel entering the site of basic precautions to be followed when working around antennas. RF alerting signage (Warning) should be posted at the base of the proposed Monopine to inform authorized climbers of potential conditions near the antennas. These recommendations are depicted in Figure 2.

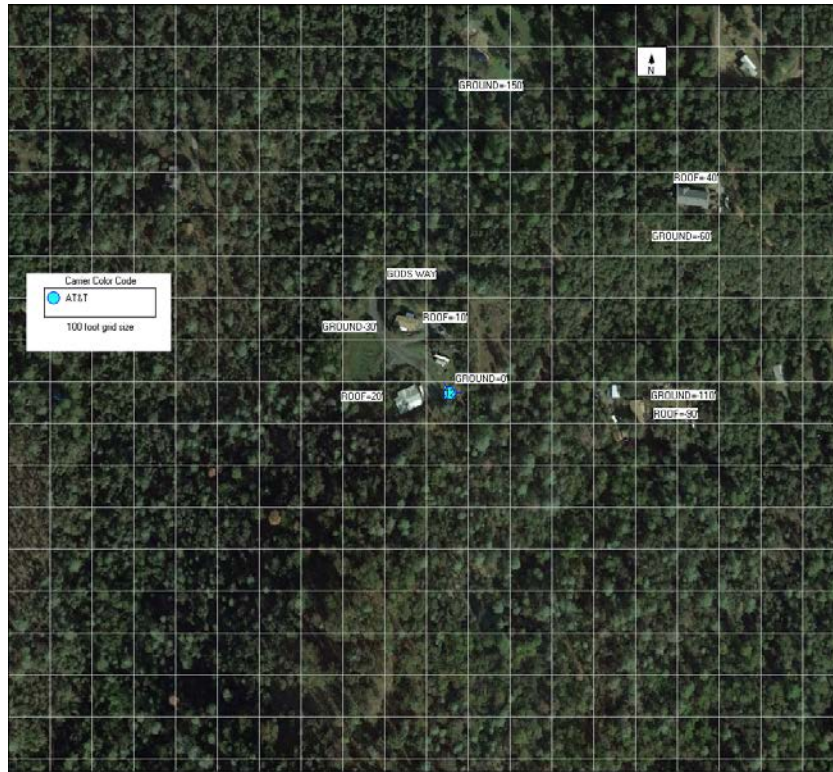

Figure 1: Antenna Locations

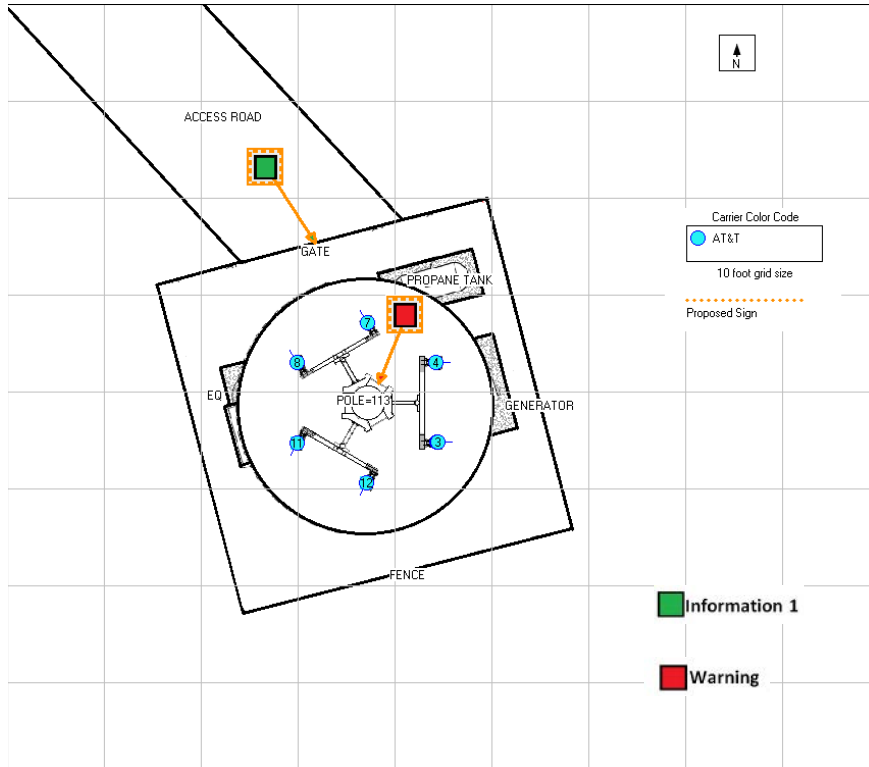

Figure 2: Mitigation Recommendations

Compliance Statement

Based on information provided by AT&T Mobility and predictive modeling, the installation proposed by AT&T Mobility at 6812 Gods Way, Lotus, CA will be compliant with Radiofrequency Radiation Exposure Limits of 47 C.F.R. § 1.1307(b)(3) and 1.1310. RF alerting signage and restricting access to the Monopine to authorized climbers that have completed RF safety training is required for Occupational environment compliance.

Certification

I, David H. Kiser, am the reviewer and approver of this report and am fully aware of and familiar with the Rules and Regulations of both the Federal Communications Commissions (FCC) and the Occupational Safety and Health Administration (OSHA) with regard to Human Exposure to Radio Frequency Radiation, specifically in accordance with FCC's OET Bulletin 65. I have reviewed this Radio Frequency Exposure Assessment report and believe it to be both true and accurate to the best of my knowledge.





on Behalf of



PROJECT SUPPORT STATEMENT

AT&T PROJECT NAME: CONNECT AMERICA FUND II (CAF II) PROJECT

DEVELOPMENT APPLICATION FOR AT&T SITE "GOLD HILL"

AT&T SITE NUMBER: CVL03054

AUTHORIZED AGENT:

EPIC WIRELESS GROUP, LLC

ZONING MANAGER:

JARED KEARSLEY; 916-755-1326; jared.kearsley@epicwireless.net

PROPERTY OWNER: ANNE AND ROGER STROUD, KATHLEEN OCONNOR

LANDOWNER CONTACT: 530-626-4209

APN: 105-110-81-100

6812 Gods Way, Lotus, CA 95651

- **PROJECT'S BACKGROUND AND OBJECTIVES**
- **SEARCH RING'S DESCRIPTION AND OBJECTIVES**
- **POTENTIAL CO-LOCATIONS**
- **ALTERNATIVE SITE ANALYSIS**
- **SUBJECT PARCEL AND SITE DETAILS AND SUPPORTING DOCUMENTS**
- **OPERATIONAL STATEMENT**
- **FIRE SUPPRESSION SYSTEM**
- **OTHER CONSIDERATIONS RELATING TO NEW WIRELESS TELECOMMUNICATION FACILITIES PURSUANT TO 17.14.210 AND 17.22.500 OF THE EL DORADO COUNTY ZONING CODE**

Exhibit J
Site 7 Gold Hill



on Behalf of



Project Background and objectives:

AT&T is participating in a Federal Government funded project called Connect America Fund (CAF) – which is to provide underserved areas throughout the United States in general and throughout El Dorado County in particular with hi-speed broadband internet. The build-up of hi-speed broadband internet throughout rural/underserved areas will not only drive economic growth in rural America, but will expand the online marketplace nationwide, creating jobs, educational and businesses opportunities across the country. The CAF project is required to provide broadband internet services capable of 10 Mbps download and 1 Mbps upload speeds.

AT&T has the necessary technology that allows them to build out their territory in El Dorado County with the much demanded hi-speed broadband internet to help improve the county’s rural infrastructure. AT&T’s basis for transmitting and receiving hi-speed broadband internet to residences is executed by providing one site with either a microwave fiber hop or a direct fiber line to the site and transferring the high speeds of fiber to each Living Unit (LU) via wireless signals. Each LU being provided with the service will have a small square antenna located in a vantage point on the property where it has a direct line of site to the tower. The square antenna will send and receive wireless broadband internet providing the LU with a minimum of 10/1 Mbps download and upload speeds, respectively.

AT&T’s secondary objective is to provide and enhance AT&T’s Wireless Telecommunications services (cellular services) to underserved areas. Cellular services go hand in hand with building the internet infrastructure throughout these underserved areas. People today rely on their mobile devices not only for educational and business purposes, but also for emergency services. Increasing AT&T’s cellular coverage and capacity throughout El Dorado County’s rural areas while providing wireless broadband internet will greatly assist with enhancing the county’s economic growth and the area’s infrastructure.

Given the need for direct line of site to residences, a taller than typical tower will be necessary in order to provide wireless broadband internet services to as many homes in the targeted areas as possible. During the tower design phase, the Radio Frequency (RF) engineer study many variables including surrounding tree heights, tree densities, population densities, and surrounding hill tops, in order to properly design a sufficient tower height with the goal of achieving the FCC’s track census block mandates of reaching specific LU coverage objectives per area. Living Unit (LU) coverage objectives are provided by the RF engineer using density maps and are based on the area’s approximate population. AT&T’s goal is not only to reach the coverage objective, but to outperform the coverage objective to ensure that the maximum amount of homes are being provided this service while taking into consideration a small margin of error during the simulation process.

Search Ring's Description and Objectives:



AT&T Mobility is proposing to build and maintain an unmanned wireless telecommunication facility consisting of a 35' x 40' (1,400) square foot enclosed compound (lease area). The compound will include a 112 foot Stealth Monopine tower, one equipment shelter, one 35kw standby propane generator, and one 500 gallon propane tank. This facility will be located at 6812 Gods Way, Lotus, within El Dorado County's jurisdiction in a 10 acre RL-10 zone. The site is approximately 0.5 miles South of Jacobs Creek and the area consists of evergreen trees, and rolling hills with rocky terrain.

AT&T's objective for the Gold Hill site is to provide wireless hi-speed broadband internet and cellular services to the nearby residences. This site is to provide hi-speed internet and enhanced cellular coverage & capacity to the Lotus area, in all directions of the search ring which is a relatively dense underserved area. The site location's elevation is approximately 1,105 feet while the surrounding community's elevation averages around 850 feet, giving the homes within the community great potential for line of site to the tower. After running a coverage simulation at the site location, AT&T is anticipating meeting their FCC objective for this Search Ring.

Potential Co-locations:

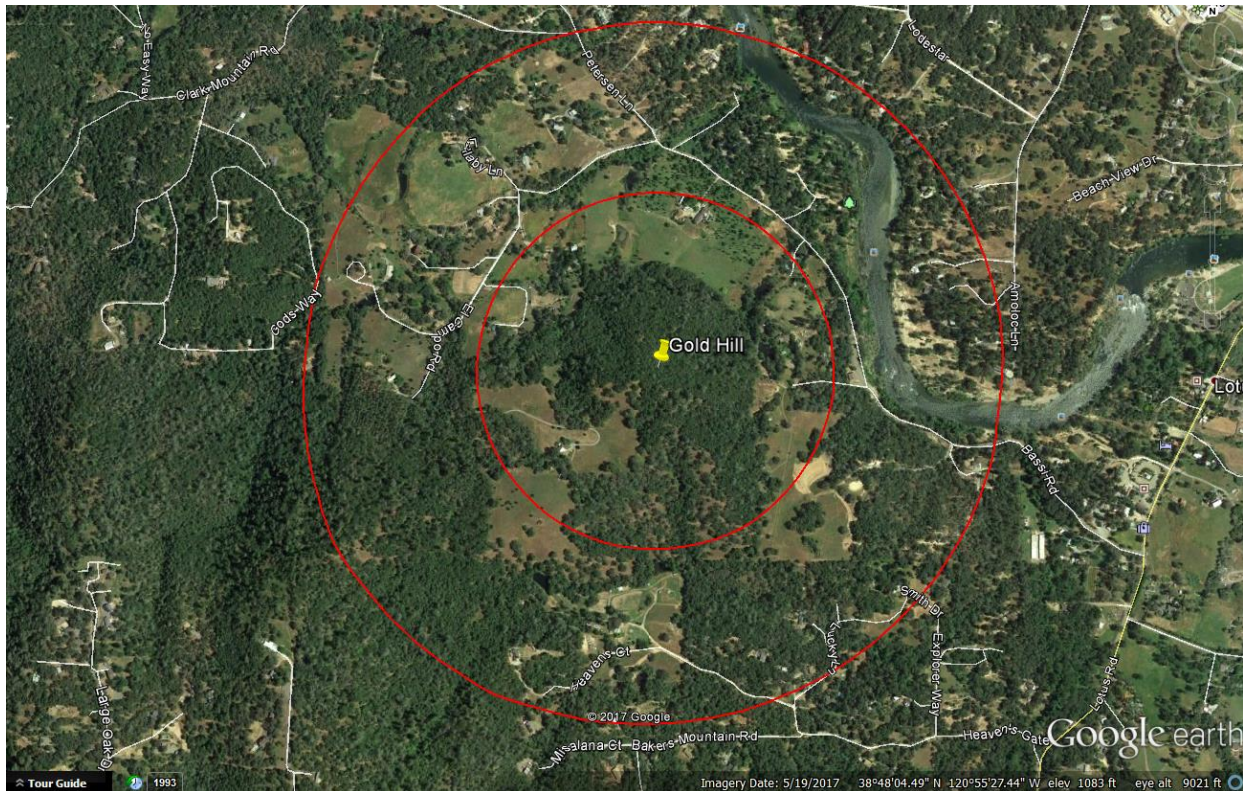

There are no potential Co-location opportunities in the near vicinity of the provided Search Ring. The targeted area is a relatively low populated area, therefore, typical cellular services are less prone to be present.

The nearest wireless facility is located approximately 2.5 miles northeast on a hill top in the Coloma area. The tower is owned by American Tower Co. (ATC) and was designed to cover the Coloma area. The existing ATC tower does not support CAF II coverage for AT&T's targeted area in for their Search Ring Gold Hill.

Alternative Site Analysis pursuant to 17.14.210 (B) (1):

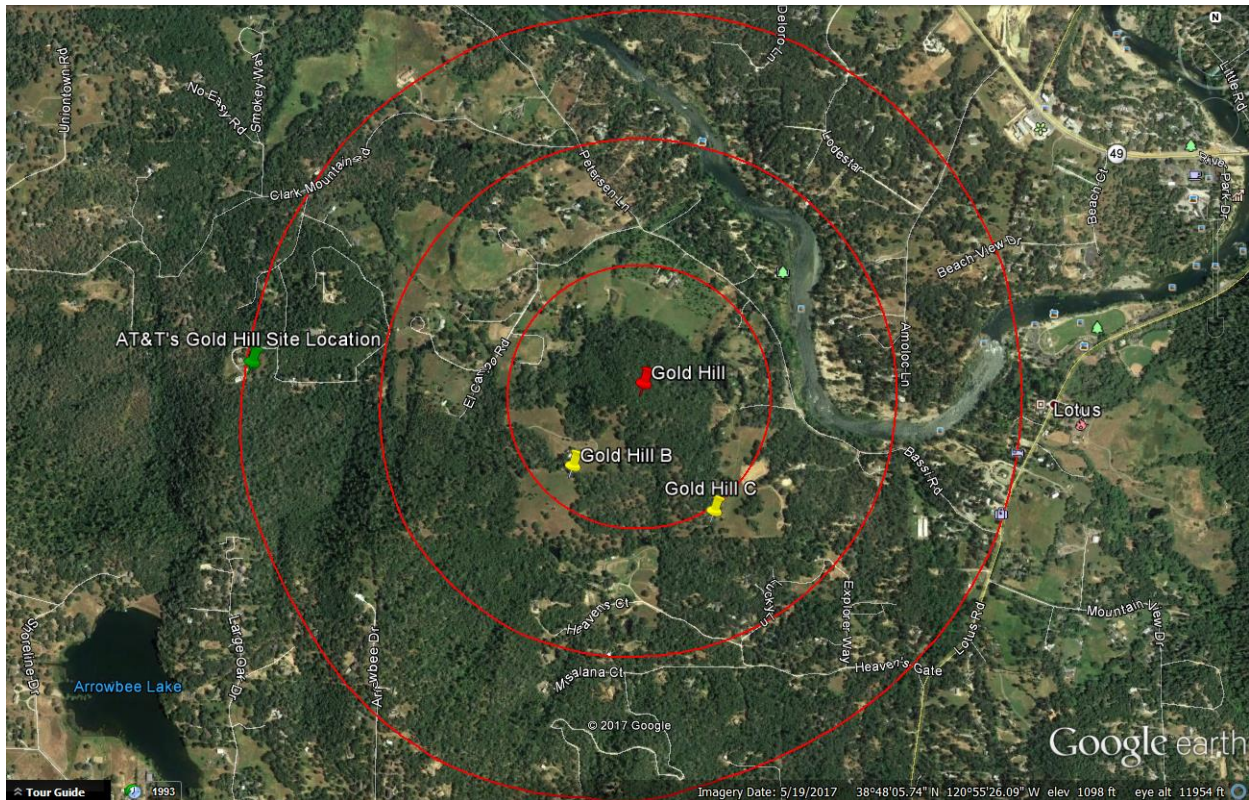

Above is a map showing the Search Ring (center is the red pin), Proposed Site (green pin) and the two alternative sites (yellow pins) that were considered for placement of the telecommunications facility. Each Alternative Site is discussed below:

Gold Hill Alternative Candidate B:

1111 El Campo Road, Lotus, CA 95651

Latitude/Longitude: 38.799644, -120.926345

Proposal – New Tower



Considerations:

Candidate B is located approximately 1,095 feet south-west of the center of AT&T's search ring. The proposed tower would be located on an 89.52 acre, RE-5 zoned property owned by Charles and Susan Tryson. The property is located at the end of El Campo Road and the site was proposed on the south side of the property. Candidate B was selected as AT&T's third candidate as the site yielded approximately 20% fewer LU's than the subject property located on Gods Way. The nearest home to the site was approximately 1,100 feet away resulting in a very unobtrusive site location. No oak woodlands were anticipated needing to be removed. The surrounding Land Uses for the area are RR, LDR, and OS. After the initial primary candidate became disqualified, Epic reached out to both the Stroud's on Gods Way and Candidate B, and unfortunately, Candidate B was no longer interested. AT&T found this information permissible given the chosen candidate on God's Way produced 20% more LUs than Candidate B.

Gold Hill Alternative Candidate C:

105-090-03-100; Placerville, CA 95667 (Property does not have a physical address)

Latitude/Longitude: 38.798162, -120.920812

Proposal – New Tower



Considerations:

Candidate C is located approximately 1,460 feet south-east of the center of AT&T's search ring. The proposed tower would be located on a 15.34 acre, RE-5 zoned property owned by Robert and Denise Hansen. The property is located on the south side of Bassie Rd and the site was proposed on the south side of the property. Candidate C was originally chosen as AT&T's primary candidate as the RF Engineer's simulation yielded 6% more LU's than the subject site located at 6812 Gods Way (Subject Parcel). However, the site location was disqualified after further due diligence and found the adjacent dwelling unit's septic system interfered with AT&T's access route. An alternative access route was entertained, however, the cost was too high given the great amount of ground disturbance required for said new access route. For those reasons, the candidate was disqualified indefinitely. The other site's qualities became irrelevant given the site was not feasible any longer.



on Behalf of

Additional alternative sites considered and letters of interest sent out but received either no response by landlords or uninterested landlords included the following parcels:

5500 Bassi Road, Lotus, CA 95651 – APN: 105-080-27; Owner: Edward & Theresa Markie

4890 Heavens Court, Lotus, CA 95651 – APN: 105-150-09; Owner: Greg and Stephanie Spangler

6920 Gods Way, Lotus, CA 95651 – APN: 105-110-60; Owner: Kevin Barchers

1988 Lullaby Lane, Lotus, CA 95651 – APN: 105-080-88; Owner: Danny and Deanna Lulla

4400 Baker Road, Placerville, CA 95667 – APN: 105-150-16; Owner: Thoren and Anna Tivol

Actual View of the Proposed Location:

The proposed lease area is located on the south-east side of the subject property. The site will not interfere with the existing Land Use of the property (RR). Access will be directly off of Gods Way. The site is elevated above the surrounding area and has great potential for line of site to the communities down below the subject parcel. The nearest home to the site location is approximately 470 feet to the east which is substantially below grade of the site location. The next nearest home is approximately 730 feet due northeast and is also substantially below grade of the site. Dense foliage is present between the site location and both residences that will naturally stealth their view to the tower. No Oak Woodlands are required to be removed and no oaks will be significantly impacted. No Special Species or animals will be affected by the installation, per Sycamore Environmental Consultants, Inc.



on Behalf of

Planning Services

Home > Government > Planning

PARCEL DATA INFORMATION

7/31/2017

*Enter
Another
Parcel*

Assessor's Parcel Number: **105-110-81**

PROPERTY INFORMATION:

STATUS	JURISDICTION	TAX RATE	MAP	ACREAGE
ON ASSESSMENT ROLL AND TAXED	COUNTY OF EL DORADO	72 - 36	RS 30/127/1	10.065

2015 GENERAL PLAN LAND USE INFORMATION:

LAND USE DES.	AG DIST.	ECOLOGICAL PRESERVES	IMPORTANT BIOLOGICAL CORRIDOR	MINERAL RESOURCES	PLATTED LANDS	COMMUNITY REGIONS	RURAL CENTERS	SPECIFIC PLANS	ADOPTED PLAN NAME
RR			IBC						

2015 ZONING INFORMATION:

ZONING DESIGNATION	DESIGN CONTROL	PLANNED DEVELOPMENT	OTHER OVERLAYS
RL-10			

2004 GENERAL PLAN LAND USE INFORMATION:

LAND USE DES.	AG DIST.	ECOLOGICAL PRESERVES	IMPORTANT BIOLOGICAL CORRIDOR	MINERAL RESOURCES	PLATTED LANDS	COMMUNITY REGIONS	RURAL CENTERS	SPECIFIC PLANS	ADOPTED PLAN NAME
RR			IBC						

2004 ZONING INFORMATION:

ZONING DESIGNATION	DESIGN CONTROL	PLANNED DEVELOPMENT	OTHER OVERLAYS
RE-10			

DISTRICTS:

FIRE	CSD	SCHOOL	WATER
EL DORADO COUNTY FPD		GOLD TRAIL UNION	UNASSIGNED

FLOOD ZONE INFORMATION (See Note below):

FIRM PANEL NUMBER & REVISION	PANEL REVISION DATE	FLOOD ZONE	FLOOD ZONE BUFFER	FLOODWAY
06017C0475E	09/26/2008	X		

MISCELLANEOUS DATA:

SUPERVISORIAL DISTRICT	AG PRESERVE	RARE PLANT MITIGATION AREA	MISSOURI FLAT MC&FP
4 MICHAEL RANALLI			No

REMARKS:

Eligibility Review Required

NOTE: The flood zone information presented here is based solely on data derived from the FEMA Flood Information Rate Maps, and does not include data from any other flood studies.

Ref ID: Gold Hill

Property Detail Report

For Property Located At :
6812 GODS WAY, LOTUS, CA 95651-9719



Owner Information

Owner Name: STROUD ANNE L & A L
Mailing Address: 6812 GODS WAY, LOTUS CA 95651-9719 H001
Vesting Codes: / A / TR

Location Information

Legal Description:	RS 30/127/1	APN:	105-110-81-100
County:	EL DORADO, CA	Alternate APN:	105-110-81-100
Census Tract / Block:	309.01 / 1	Subdivision:	
Township-Range-Sect:		Map Reference:	/
Legal Book/Page:		Tract #:	
Legal Lot:		School District:	EL DORADO UN
Legal Block:		School District Name:	
Market Area:		Munic/Township:	
Neighbor Code:			

Owner Transfer Information

Recording/Sale Date:	10/06/2015 / 09/29/2015	Deed Type:	TRUSTEE'S DEED(TRANSFER)
Sale Price:		1st Mtg Document #:	
Document #:	46447		

Last Market Sale Information

Recording/Sale Date:	07/21/2006 / 07/11/2006	1st Mtg Amount/Type:	\$266,000 / CONV
Sale Price:	\$512,500	1st Mtg Int. Rate/Type:	/
Sale Type:	FULL	1st Mtg Document #:	49173
Document #:	49172	2nd Mtg Amount/Type:	/
Deed Type:	GRANT DEED	2nd Mtg Int. Rate/Type:	/
Transfer Document #:		Price Per SqFt:	\$333.01
New Construction:		Multi/Split Sale:	
Title Company:	PLACER TITLE CO.		
Lender:	WASHINGTON MUTUAL BK FA		
Seller Name:	APGAR BOB & DIANA TRUST		

Prior Sale Information

Prior Rec/Sale Date:	06/27/2000 / 06/21/2000	Prior Lender:	LENDER SELLER
Prior Sale Price:	\$52,000	Prior 1st Mtg Amt/Type:	\$42,000 / CONV
Prior Doc Number:	31503	Prior 1st Mtg Rate/Type:	/ FIX
Prior Deed Type:	GRANT DEED		

Property Characteristics

Gross Area:		Parking Type:		Construction:	
Living Area:	1,539	Garage Area:		Heat Type:	
Tot Adj Area:		Garage Capacity:		Exterior wall:	
Above Grade:		Parking Spaces:		Porch Type:	
Total Rooms:	6	Basement Area:		Patio Type:	
Bedrooms:	3	Finish Bsmnt Area:		Pool:	
Bath(F/H):	2 /	Basement Type:		Air Cond:	
Year Built / Eff:	2001 / 2001	Roof Type:		Style:	
Fireplace:	/	Foundation:		Quality:	GOOD
# of Stories:	1.00	Roof Material:		Condition:	AVERAGE
Other Improvements:					

Site Information

Zoning:	RE-10	Acres:	10.06	County Use:	MOBILE HOME ON 2.5+ AC (28)
Lot Area:	438,431	Lot Width/Depth:	x	State Use:	
Land Use:	MOBILE HOME	Res/Comm Units:	2 /	Water Type:	
Site Influence:				Sewer Type:	

Tax Information

Total Value:	\$324,500	Assessed Year:	2016	Property Tax:	\$3,361.62
Land Value:	\$123,500	Improved %:	62%	Tax Area:	072036
Improvement Value:	\$201,000	Tax Year:	2016	Tax Exemption:	HOMEOWNER
Total Taxable Value:	\$317,500				



on Behalf of



Assessor's Parcel Map

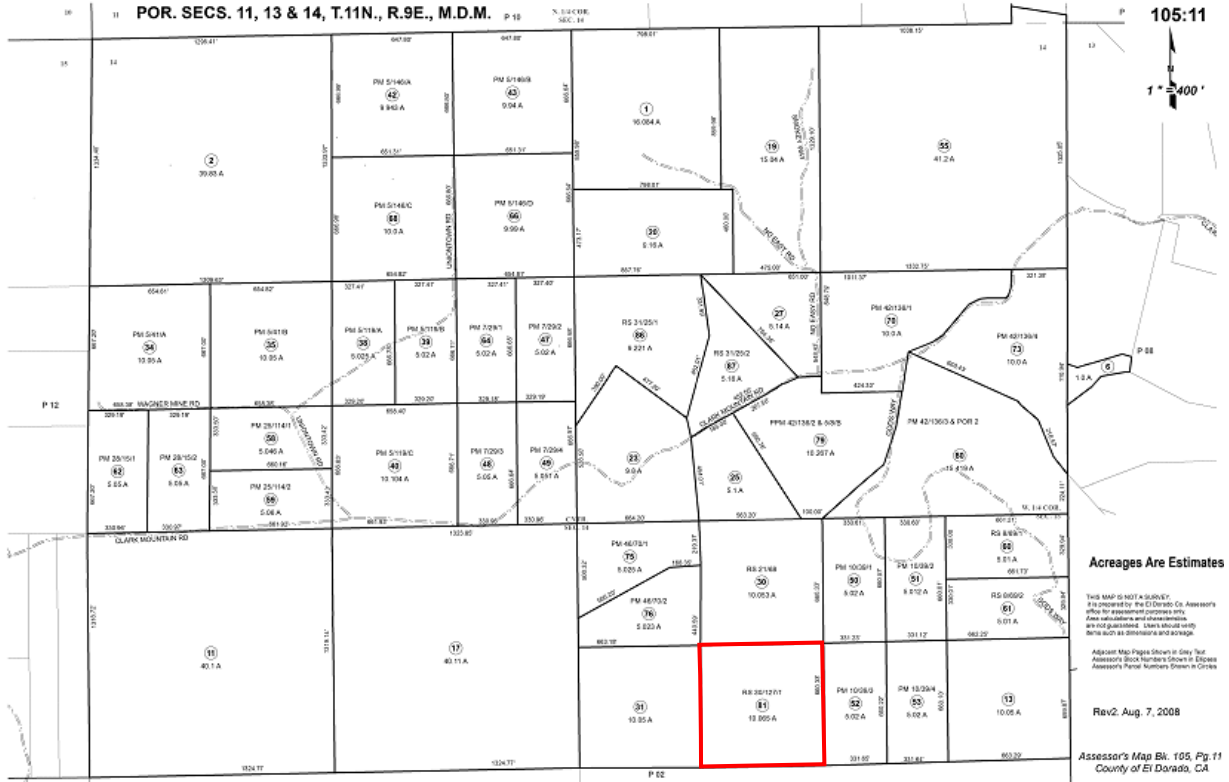

El Dorado County Assessor Web Map

By Shape By Value By Spatial Results

Features selected: 1

10511081

APN_STATUS: 0

USECDPRI: 28

ACREAGE: 10.065

LEGAL_DESC: RS 30/127/1

SUBDIVNAME: UNASSIGNED

ZONEDES: RL-10

[Go To Property Information Screen](#)

38.806 -120.944 Degrees

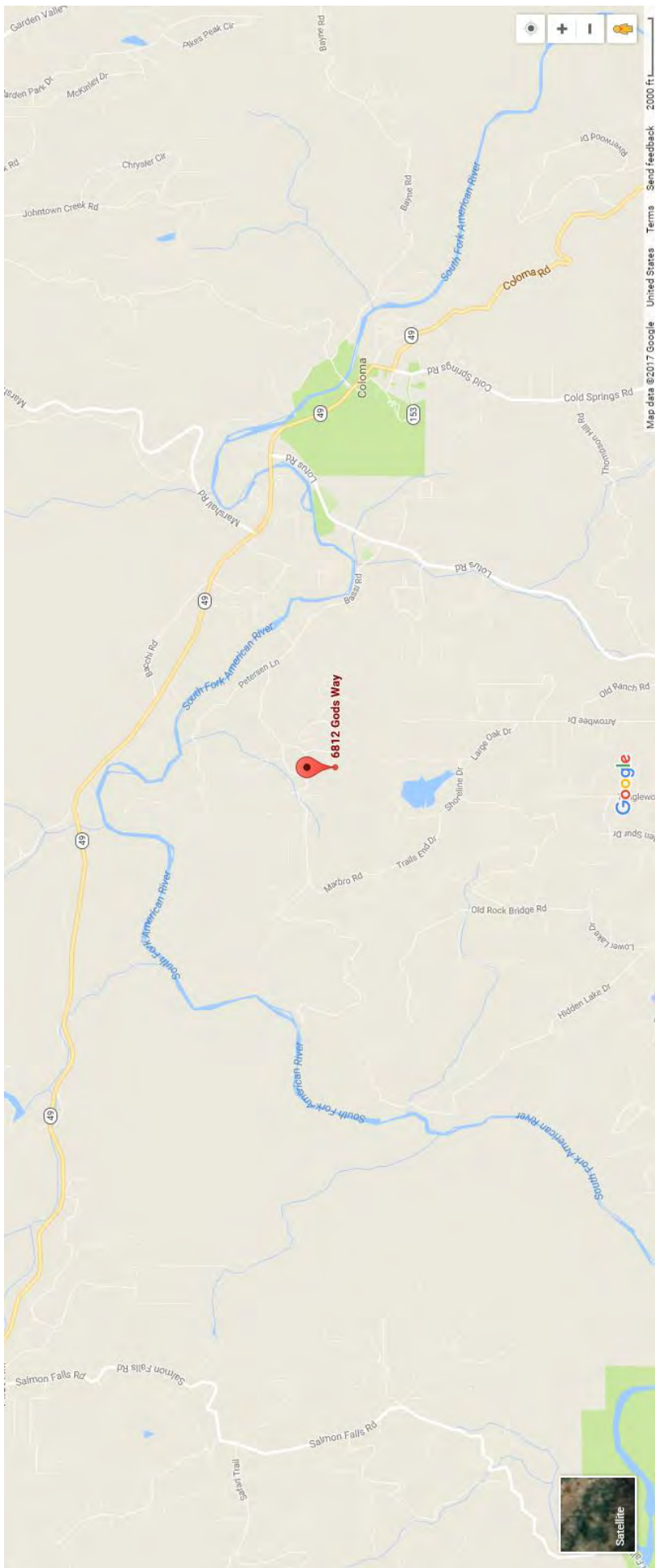

Overhead View of Lease Area and Distances to nearby residences:

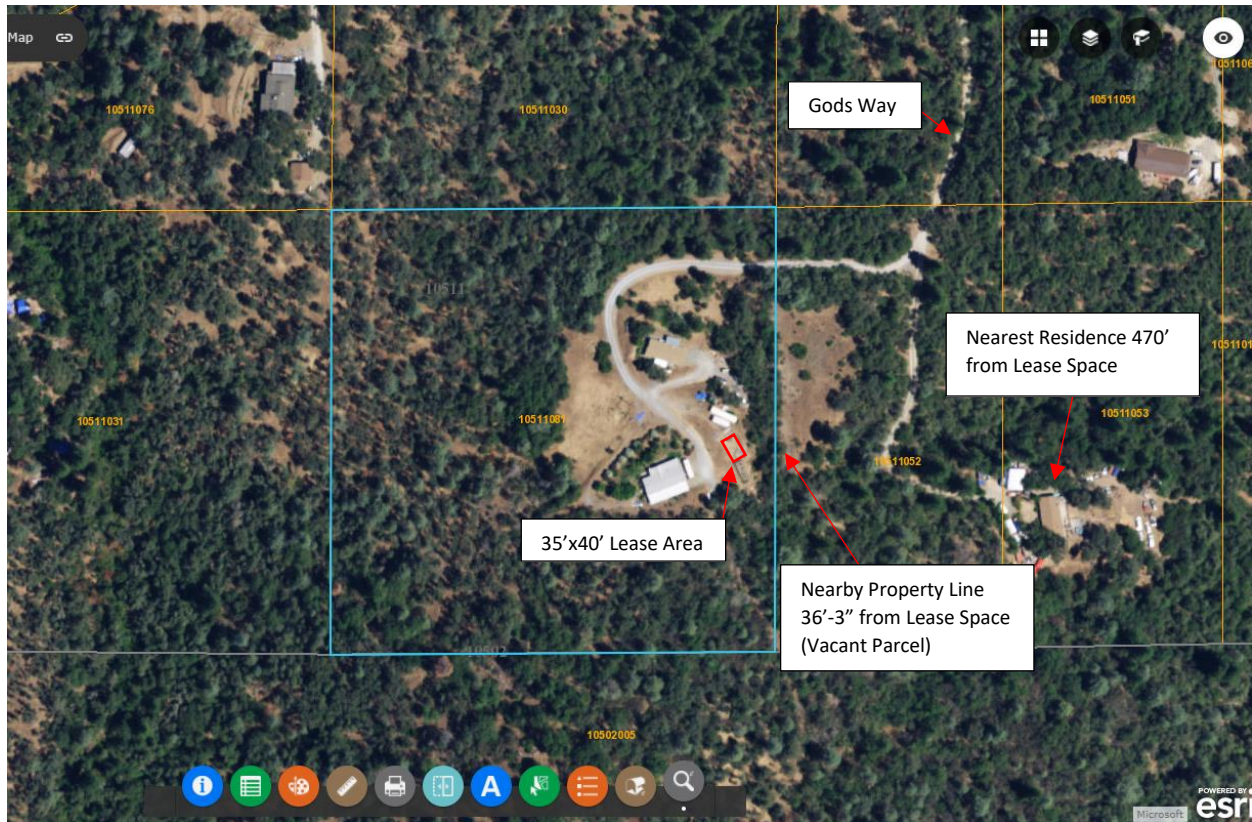

Emergency 35kw Propane Generator and 4 Ton HVAC Noise Analysis:

○ **Equation and Calculation Method:**

The sound analysis methods and results are hypothetical only, using Sound Level and Distance calculations. These calculations do not take outside sounds, trees, hills, buildings, and other sound dampening variables into consideration, but, only raw sound levels after specific traveled distances which results in the worst case scenario for the sounds of the onsite backup generator and HVAC systems.

The use of emergency equipment is exempted from these limits per section 130.37.20(B).

Formulas to calculate the sound level L in dB (sound pressure level or sound intensity level) in dependence of the distance r :

Sound level L and Distance r	
$L_2 = L_1 - 20 \cdot \log\left(\frac{r_1}{r_2}\right) $	$L_2 = L_1 - 10 \cdot \log\left(\frac{r_1}{r_2}\right)^2 $
$r_2 = r_1 \cdot 10^{\left(\frac{L_1 - L_2}{20}\right)}$	$r_1 = \frac{r_2}{10^{\left(\frac{L_1 - L_2}{20}\right)}}$
Sound pressure level (dB) = Sound intensity level (dB)	
$L_2 = L_1 - 20 \cdot \log\left(\frac{r_1}{r_2}\right) $	$L_2 = L_1 - 10 \cdot \lg\left(\frac{r_1}{r_2}\right)^2$

Sound Specifications:

- Emergency Generator Model: SG035 Generac
 - Average decibel (dBA) level at 23 feet = 64.9 dBA
- HVAC Model: ASDCA48
 - Average decibel (dBA) level at 50 feet = 57 dBA

Sound Specifications while taking the Sound Blanket into consideration:

- Emergency Generator Model: SG035 Generac
 - Average decibel (dBA) level at 23 feet = 58.11 dBA
- HVAC Model: ASDCA48
 - Average decibel (dBA) level at 50 feet = 46.36 dB

Findings:

1. Distance to the nearest property line = 36'-3"
 - a. Generator Decibel level at 36'-3" = 54.16 dBA
 - b. HVAC Decibel level at 36'-3" = 49.15 dBA
2. Distance to a nearest residence = 470'
 - a. Generator Decibel level at 470' = 31.9 dBA
 - b. HVAC Decibel level at 470' = 26.9 dBA

Conclusion:

After calculating all decibel levels at each nearby residence's property line and actual residence, the onsite Emergency Backup Generator and HVAC systems are within El Dorado County's noise level standards according to El Dorado County Title 130 Zoning and Noise Ordinance, Chapter 130.37 – Noise Standards.

Table 1 – Eldorado County Table 130.37.060.1
Noise Level Performance Standards for Noise Sensitive Land Uses
Affected by Non-Transportation Sources

Noise Level Descriptor	Daytime 7 a.m. – 7 p.m.		Evening 7 p.m. – 10 p.m.		Night 10 p.m. – 7 a.m.	
	Community / Rural Centers	Rural Regions	Community / Rural Centers	Rural Regions	Community / Rural Centers	Rural Regions
Hourly Leq, dBA	55	50	50	45	45	40
Maximum Level, dBA	70	60	60	55	55	50

BBC-13X Sound Curtains

Sound Seal’s **BBC-13X** offers the benefits of both a noise barrier and a sound absorber for outdoor applications. The BBC-13X consists of a one-inch thick vinyl-coated-fiberglass-cloth faced quilted fiberglass that is bonded to a one-pound per sq. ft. reinforced loaded vinyl noise barrier. **“X”** style Sound Curtain panels are constructed with grommets across the top and **bottom, and exterior grade** Velcro seals along the vertical edges. The product is also available in roll form with edges bound or unbound.



- Class A (or 1) flammability rated per ASTM E 84
- For use on Indoor or Outdoor Applications
- Available facing colors: gray, tan, black, or off-white
- Available barrier colors: gray, tan, blue or olive drab

Applications:

Even in the harshest environments, with a minimum life span of 5 years* and wind load ratings of 120 mph, this product is typically used as a **temporary noise barrier on outdoor applications such as construction site noise mitigation projects**. Also available with a two-pound psf noise barrier or a two-inch thick quilted fiberglass sound absorber for better acoustical performance.

Product Data:

Description	Vinyl coated fiberglass cloth facing on 1” quilted fiberglass 1lb-psf reinforced loaded vinyl barrier
Flammability	Flame Spread: 23.0 Smoke density: 30.0
Nominal thickness	1.0 inch
Temperature range	-20° to +180° F
Standard roll size	54” wide x 25’ long
Weight	1.2 lb psf

Acoustical Performance:

Product	Sound Transmission Loss						
	OCTAVE BAND FREQUENCIES (Hz)						
	125	250	500	1000	2000	4000	STC
BBC-13 X	11	16	24	30	35	35	27

ASTM E-90 & E 413

Product	Sound Absorption Data						
	OCTAVE BAND FREQUENCIES (Hz)						
	125	250	500	1000	2000	4000	NRC
BBC-13 X	.12	.47	.85	.84	.64	.62	.70

ASTM C 423

* when properly installed.



on Behalf of



Operation Statement:

This project is an AT&T Mobility unmanned Telecommunication Wireless Facility. It will consist of the following:

NEW SITE BUILD UNMANNED TELECOMMUNICATIONS FACILITY.

1. **(1) NEW 12' WIDE GRAVEL ACCESS ROAD**
2. **(1) NEW 35' X 40' FENCED LEASE AREA**
3. **(1) NEW 6' CHAIN LINK FENCE**
4. **(1) NEW 12' WIDE DOUBLE ACCESS GATE**
5. **(1) NEW 112' MONOPINE TOWER**
6. **(1) NEW PRE-FAB EQUIPMENT SHELTER**
7. **(1) NEW GPS ANTENNA**
8. **(1) NEW 35KW PROPANE GENERATOR**
9. **(1) LP PROPANE TANK (500 GALLON)**
10. **(12) NEW ANTENNAS**
11. **(9) NEW RRUS-11, (9) NEW RRUS-32 & (3) FUTURE RRUS**
12. **(4) NEW SURGE SUPPRESSORS**
13. **(2) FUTURE 4' M/W DISH**

The facility will operate 24 hours a day 7 days a week. Maintenance workers will visit the site approximately once a month. A 15 foot wide access route will be created directly from Gods Way. There will be minimal noise from the standby generator, turning on once a week for 15 minutes for maintenance purposes and during emergency power outages. The Facility is approximately 36'-3" feet west of the nearest property line and approximately 470 feet west of the nearest residence. The location is surrounded by evergreen trees which will naturally stealth the facility. The surrounding area is covered with evergreen tree backdrops. The tower will be built to provide co-location opportunities.

Fire Suppression System:

A 15 foot wide access route will be created directly from Gods Way. A Hammer Head Fire Turnaround will be proposed within the access route. A Fire Department Knox Box will be located at the Facility's access gate. The El Dorado County Fire Department Station 74 is only 2.5 miles east of the Proposed Facility. Additionally, a 2A:20BC Rated Fire Extinguisher in a weather resistant cabinet will be mounted on the exterior wall of the proposed shelter.



on Behalf of



Conclusion:

Candidate A, 6812 Gods Way, meets the FCC's mandated objectives for the targeted area of Gold Hill and is the best choice for the surrounding area. The chosen location will meet and exceed the FCC's mandated coverage objectives with providing hi-speed broadband internet to homes in the Targeted area of El Dorado County. The Stealth Monopine Tower design has been chosen to blend into the existing surrounding environment as the least intrusive means while filling AT&T's significant gap in coverage. The property's surrounding foliage and tree canopy will naturally camouflage the facility thereby proving low visual impact to the surrounding residents. No Oak Woodlands will be removed or significantly impacted. No special species or protected animals will be impacted per the biological resource assessment prepared by Sycamore Environmental Consultants, Inc.

**LETTER OF AUTHORIZATION
TO FILE PERMIT APPLICATIONS**

Re: El Dorado County APN # 105-110-81-100

To Whom It May Concern:

The undersigned, Landlord, are the owners of the property located at 6812 Gods Way, Lotus, CA 95651, County Assessor's Parcel No. #105-110-81-100, that is the subject of an CUP application for a new Telecommunications Facility. The undersigned has leased a portion of the property to AT&T Mobility C/O Epic Wirelss Group, and hereby authorizes Epic Wireless Group, its agent, to act as applicant to obtain any and all permits required for the approval and construction of this antenna/communication facility.

Landlord/Lessor: Roger Stroud, Anne Stroud & Kathleen OConnor



Landlord



Date

7/8/2017

CVL03054 Zoning Propagation Map

June 13, 2017

Proposed LTE 700 Coverage (RC = 108')

Legend

- In-Building Service
- In-Transit Service
- Outdoor Service
- Existing site
- Proposed site

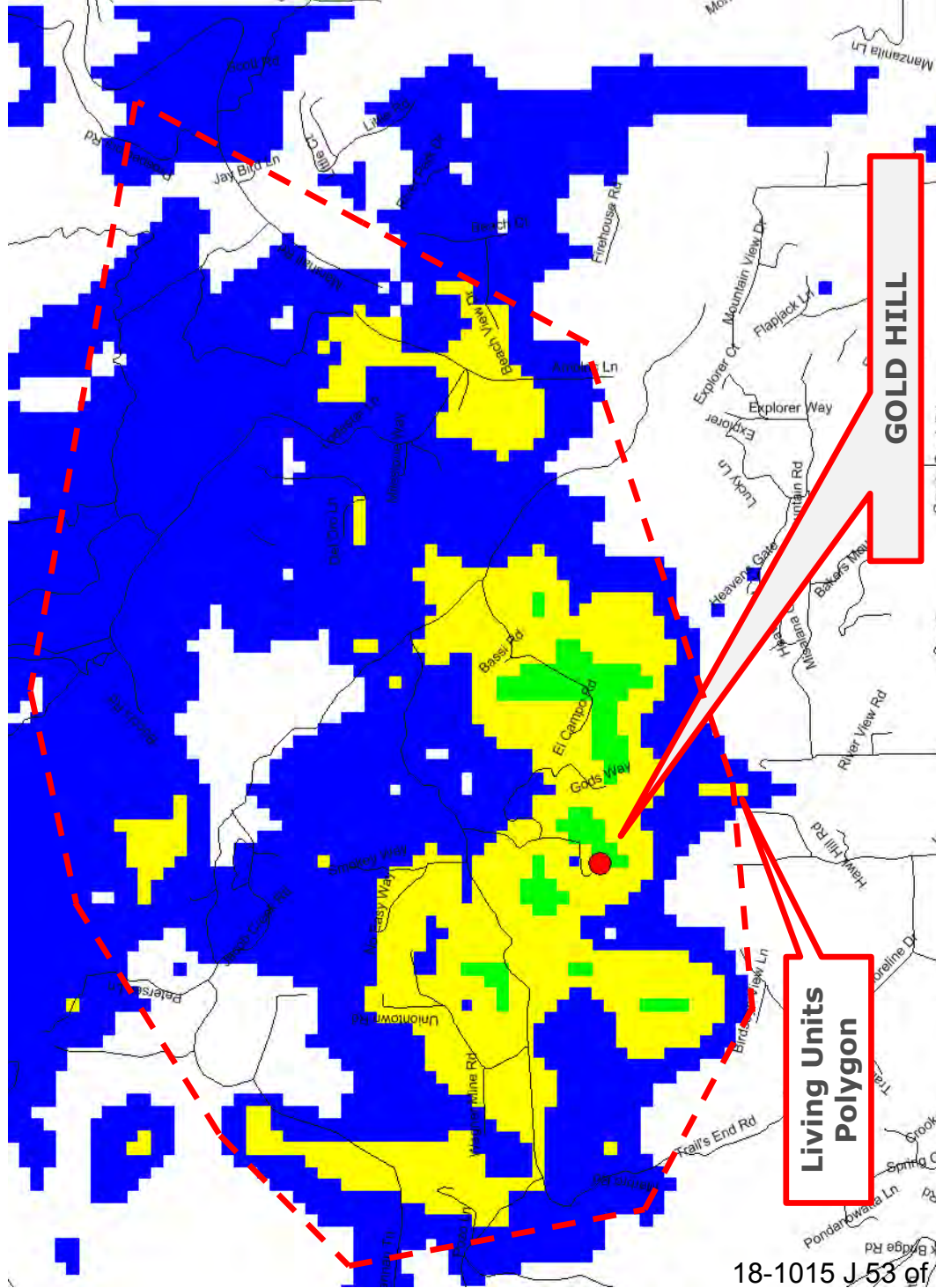

Living Units Polygon

GOLD HILL



Scale: 1:17,690

June 13, 2017





Radio Frequency Emissions Compliance Report For AT&T Mobility

Site Name: Gold Hill	Site Structure Type: Monopine
Address: 6812 Gods Way	Latitude: 38.802398
Lotus, CA	Longitude: -120.937291
Report Date: August 17, 2017	Project: New Build

General Summary

AT&T Mobility has contracted Waterford Consultants, LLC to conduct a Radio Frequency Electromagnetic Compliance assessment of the proposed Gold Hill site located at 6812 Gods Way, Lotus, CA. This report contains information about the radio telecommunications equipment to be installed at this site and the surrounding environment with regard to RF Hazard compliance. This assessment is based on installation designs and operational parameters provided by AT&T Mobility.

The compliance framework is derived from the Federal Communications Commission (FCC) Rules and Regulations for preventing human exposure in excess of the applicable Maximum Permissible Exposure ("MPE") limits. At any location at this site, the power density resulting from each transmitter may be expressed as a percentage of the frequency-specific limits and added to determine if 100% of the exposure limit has been exceeded. The FCC Rules define two tiers of permissible exposure differentiated by the situation in which the exposure takes place and/or the status of the individuals who are subject to exposure. General Population / Uncontrolled exposure limits apply to those situations in which persons may not be aware of the presence of electromagnetic energy, where exposure is not employment-related, or where persons cannot exercise control over their exposure. Occupational / Controlled exposure limits apply to situations in which persons are exposed as a consequence of their employment, have been made fully aware of the potential for exposure, and can exercise control over their exposure. Based on the criteria for these classifications, the FCC General Population limit is considered to be a level that is safe for continuous exposure time. The FCC General Population limit is 5 times more restrictive than the Occupational limits.

Frequency (MHz)	<i>Limits for General Population/ Uncontrolled Exposure</i>		<i>Limits for Occupational/ Controlled Exposure</i>	
	Power Density (mW/cm ²)	Averaging Time (minutes)	Power Density (mW/cm ²)	Averaging Time (minutes)
30-300	0.2	30	1	6
300-1500	f/1500	30	f/300	6
1500-100,000	1.0	30	5.0	6

f=Frequency (MHz)

In situations where the predicted MPE exceeds the General Population threshold in an accessible area as a result of emissions from multiple transmitters, FCC licensees that contribute greater than 5% of the aggregate MPE share responsibility for mitigation.

Based on the computational guidelines set forth in FCC OET Bulletin 65, Waterford Consultants, LLC has developed software to predict the overall Maximum Permissible Exposure possible at any particular location given the spatial orientation and operating parameters of multiple RF sources. These theoretical results represent worst-case predictions as emitters are assumed to be operating at 100% duty cycle.

For any area in excess of 100% General Population MPE, access controls with appropriate RF alerting signage must be put in place and maintained to restrict access to authorized personnel. Signage must be posted to be visible upon approach from any direction to provide notification of potential conditions within these areas. Subject to other site security requirements, occupational personnel should be trained in RF safety and equipped with personal protective equipment (e.g. RF personal monitor) designed for safe work in the vicinity of RF emitters. Controls such as physical barriers to entry imposed by locked doors, hatches and ladders or other access control mechanisms may be supplemented by alarms that alert the individual and notify site management of a breach in access control. Waterford Consultants, LLC recommends that any work activity in these designated areas or in front of any transmitting antennas be coordinated with all wireless tenants.

Analysis

AT&T Mobility proposes the following installation at this location:

- Install twelve (12) new panel antennas
- Install nine (9) new RRUS-11 Remote Radio Head units
- Install nine (9) new RRUS-32 Remote Radio Head units

The antennas will be mounted on a 113-foot monopole with centerlines at 100 and 110 feet above ground level. The antennas will be oriented toward 90, 330 and 210 degrees. The Effective Radiated Power (ERP) in any direction from all AT&T Mobility operations will not exceed 26,557 Watts. Other appurtenances such as GPS antennas, RRUs and hybrid cable are not sources of RF emissions. From this site, AT&T Mobility will enhance voice and data services to surrounding areas in licensed 700, 850, 1900, 2100 and 2300 MHz bands. No other antennas are known to be operating in the vicinity of this site.

Power density decreases significantly with distance from any antenna. The panel-type antennas to be employed at this site are highly directional by design and the orientation in azimuth and mounting elevation, as documented, serve to reduce the potential to exceed MPE limits at any location other than directly in front of the antennas. For accessible areas at ground level, the maximum predicted power density level resulting from all AT&T Mobility operations is 0.5265% of the FCC General Population limits (0.1053% of the FCC Occupational limits). Incident at adjacent buildings depicted in Figure 1, the maximum predicted power density level resulting from all AT&T Mobility operations is 0.6315% of the FCC General Population limits (0.1263% of the FCC Occupational limits). The proposed operation will not expose members of the General Public to hazardous levels of RF energy.

Waterford Consultants, LLC recommends posting contact information signage at the gate that informs personnel entering the site of basic precautions to be followed when working around antennas. RF alerting signage (Warning) should be posted at the base of the proposed Monopine to inform authorized climbers of potential conditions near the antennas. These recommendations are depicted in Figure 2.

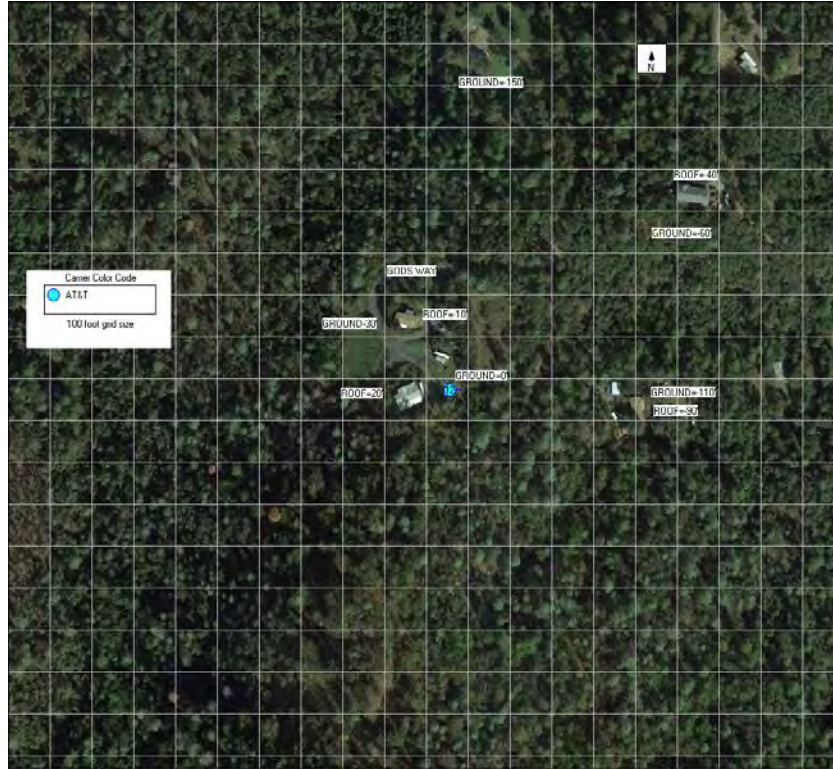

Figure 1: Antenna Locations

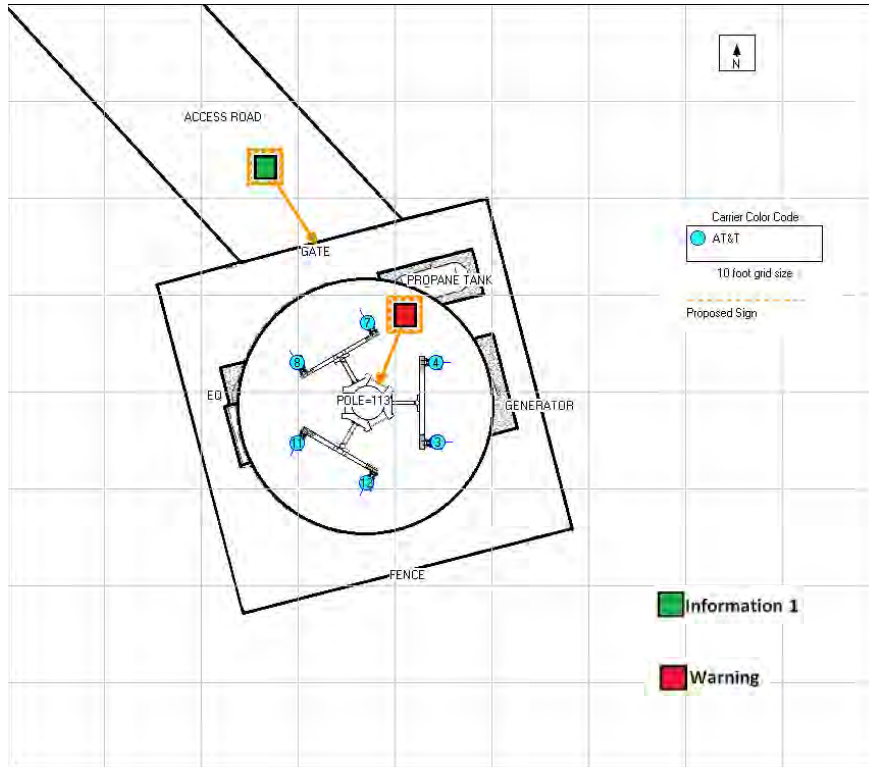

Figure 2: Mitigation Recommendations

Compliance Statement

Based on information provided by AT&T Mobility and predictive modeling, the installation proposed by AT&T Mobility at 6812 Gods Way, Lotus, CA will be compliant with Radiofrequency Radiation Exposure Limits of 47 C.F.R. § 1.1307(b)(3) and 1.1310. RF alerting signage and restricting access to the Monopine to authorized climbers that have completed RF safety training is required for Occupational environment compliance.

Certification

I, David H. Kiser, am the reviewer and approver of this report and am fully aware of and familiar with the Rules and Regulations of both the Federal Communications Commissions (FCC) and the Occupational Safety and Health Administration (OSHA) with regard to Human Exposure to Radio Frequency Radiation, specifically in accordance with FCC's OET Bulletin 65. I have reviewed this Radio Frequency Exposure Assessment report and believe it to be both true and accurate to the best of my knowledge.





**Marvair DC Free Air HVAC Unit
with 48 VDC Evaporator Fan Motor, 100%
Free Cooling and CoolLinks™ Controller**

Models ASDCA36-42-48-60-72

PRELIMINARY

General Description

The Marvair® ComPac® II air conditioners are designed to cool telecommunications shelters where the high internal heat load requires year round cooling-even when ambient temperatures are below 60°F (15°C). To provide cooling during a wide range of ambient conditions, the ASDCA air conditioners have the necessary controls and components for year round cooling. The unit uses the non-ozone depleting R-410A refrigerant.

DC power provides emergency cooling/ventilation

Should there be loss of power to the site, the Marvair DC Free Air unit will continue to cool/ventilate the site by utilizing DC power to introduce outside air into the shelter for free cooling. The DC Free Air unit will continue to ventilate the site and extend the run time of the equipment until battery power is exhausted or, at the minimum, owner specified pull down of battery drain.



ASDCA36

The ASDCA models operate on both AC and DC power. The compressor, condenser fan motor and electric heat operate on AC power, but the evaporator motors, the 100% free cooling economizer damper and the internal control board operate on DC power – an inverter is **not** required. Since these key components are all powered by 48 VDC – the same 48 VDC power used by the shelter's radios- they are always operational.

The 48 VDC power supply connects to an internal DC breaker. From this breaker, power is supplied to the DC indoor blower and control board. A 48 VDC to 24 VDC converter powers the 100% DC free cooling damper.

Free Cooling with the Marvair 100% Full flow Economizer

When the outside air is cool and dry, the economizer damper opens and draws in filtered, outside air to cool the shelter. The Marvair 100% full flow economizer means the same CFM of outside air is brought into the shelter as the rated air flow of the unit. The innovative design of the full flow economizer assembly also allows outside air to exit the building – pressure relief- when the full flow economizer is operating. This design eliminates the need for additional, costly penetrations in the shelter.

Free cooling provides temperature control, energy savings, and increased reliability by decreasing the operating hours of the compressor and the condenser fan. To insure proper operation and optimum performance, all economizers are non-removable, factory installed and tested.

CoolLinks™ PLC controller

The Siemens PLC-based CoolLinks controller sequences the operation of the two Marvair ComPac II units to ensure the most energy-efficient conditioning of the shelter space and the most balanced use of the conditioning equipment. The CoolLinks system determines the need to cool or heat the shelter based on an indoor temperature sensor and outside temperature/humidity sensor connected directly to the controller. When cooling or heating is required, the controller selects the unit that was not running in the previous cooling/heating cycle. This lead/lag operation ensures that each unit receives equal runtime and therefore extends the operating life of the units. In the event that one of the units is unavailable, for example, scheduled maintenance, the system will automatically select the active unit. Similarly, if the internal shelter temperature continues to rise/fall, the system will run both units.

For cooling requests, the CoolLinks controller first examines the external shelter conditions to establish whether DC Free Cooling is possible. If acceptable, the 100% full flow economizer damper on the lead unit is opened to 100%. The damper then modulates its position, regulated by the controller, to cool the shelter to the target set point. During extreme cold outdoor temperatures this prevents “shocking” the equipment in the shelter.

If DC Free Cooling is active on one unit and the internal temperature continues to rise, DC Free Cooling will then be activated on the second unit. Should the temperature continue to rise, the DC Free Cooling will be disabled on both units, both economizer dampers will be closed, and mechanical cooling activated on the lead unit. The control scheme allows the CoolLinks controller to make as efficient use of the external air as possible to minimize HVAC power consumption.

The CoolLinks controller communicates with the Marvair air conditioners over Ethernet. Should communications between the controller and one of the units fail, the unit will continue to run in stand-alone mode and cool to a mixed-air set point of 55°F (12.8°C). Whenever communications are restored, the CoolLinks controller will assume control of the air conditioner. An Ethernet connection is also provided for a SNMP interface through which the Network Operations Center can receive traps (alarms), monitor/change cooling and heating set points, and monitor HVAC unit and system operational parameters.

Air Conditioner Alarms and Lockouts

Each air conditioner is monitored over Ethernet and if a problem is detected, an alarm is generated. The alarm is displayed on the CoolLinks PLC in the shelter **and** sent via SNMP trap to the network operations center.

- High Pressure Alarm – the refrigerant pressure has exceeded the set point pressure *once* in a cooling cycle. The air conditioner will continue to operate, but notification is sent that there is a high pressure fault.
- High Pressure Lockout Alarm - the refrigerant pressure has exceeded the set point pressure *twice* in a cooling cycle. The air conditioner will shut down and notification will be sent that there is a high pressure lockout.
- Low Pressure Alarm – the refrigerant pressure has dropped below the set point pressure *once* in a cooling cycle. The air conditioner will continue to operate, but notification is sent that there is a low pressure fault.
- Low Pressure Lockout Alarm - the refrigerant pressure has dropped below the set point pressure *twice* in a cooling cycle. The air conditioner will shut down and notification will be sent that there is a low pressure lockout.
- Damper Alarm – if the 100% full flow damper does not open when required, an alarm notification is sent that the damper is not open.
- Dirty Filter Alarm – a switch monitors the pressure on either side of the filter. If the differential pressure exceeds the set point pressure, an alarm notification is sent that there is not sufficient air flow through the filter.
- Communications Alarm – a signal is sent if there is a loss of communication between the air conditioner and the CoolLinks controller.

Shelter & System Alarms

- In addition to the HVAC alarms, the CoolLinks controller also provides Shelter and System alarms. The alarm is displayed on the CoolLinks PLC in the shelter **and** also sent via SNMP trap to the network operations center.
- First Stage High Temperature Alarm – Inside temperature above 85°F (29.4°C).
- Second Stage High Temperature Alarm – Inside temperature above 90°F (32.2°C).
- Low Temperature Alarm - Inside temperature is below 45°F (7.2°C).
- Landline Power Alarm – A loss of landline power.
- Smoke Alarm - If the smoke sensor input to the CoolLinks system is active, the Compressor, Heater, and Indoor Blower Motor on both HVAC units will be shut down and the damper will closed completely. This will stop air flow within the shelter.
- Hydrogen Detector Alarm- If the hydrogen sensor input to the CoolLinks system is active, the damper(s) on units that are not currently in mechanically cooling will be fully opened and the Indoor Blower Motor(s) will be turned on. This will expel noxious gases and introduce outside air into the shelter. If one unit is in mechanical cooling, it will continue to run. The other air conditioner will turn on and operate in the emergency ventilation mode.
- Generator Operation Alarm - If the generator running input to the CoolLinks system is active, only one HVAC unit will be permitted to run in mechanical cooling. As the generator is typically sized to run only one HVAC unit, this ensures that the generator load is not exceeded.

Remote Access Data Points

Through the Ethernet connection, the network operations center can monitor and change various data points in the HVAC system and the shelter.

Data Points which can be monitored **and** changed:

- First Stage Cooling Set Point Temperature
- Second Stage Cooling Set Point Differential Temperature
- First Stage Heating Set Point Temperature
- Second Stage Heating Set Point Differential Temperature

Data points which can only be monitored:

- Inside Temperature - Current
- Outside Temperature - Current
- Outside Humidity - Current
- Dew point - Current

- Inside Temperature - Average Last Hour
- Outside Temperature - Average Last Hour
- Outside Humidity - Average Last Hour
- Dew point - Average Last Hour

- Unit 1 & Unit 2 Mechanical Cooling Time - Last Hour
- Unit 1 & Unit 2 Mechanical Cooling Requests - Last Hour
- Unit 1 & Unit 2 DC Free Air Cooling Time - Last Hour
- Unit 1 & Unit 2 DC Free Air Cooling Requests - Last Hour
- Unit 1 & Unit 2 Heating Time - Last Hour
- Unit 1 & Unit 2 Heating Requests - Last Hour

Standard Features

Designed for Operation in Low Ambient Conditions

- **Low ambient control cycles** condenser fan to maintain proper refrigerant pressures. Allows operation in mechanical cooling (compressor) down to 0°F (-18°C). Note: low temperature operation is affected by ambient conditions, e.g. wind and humidity.
- **Three minute by-pass of the low pressure switch** for start-up of compressor when outdoor temperatures are below 55°F (13°C).
- **Factory built-in economizer.**

High Efficiency

- **High efficiency compressor.**
- **Lanced fins standard on all evaporator and condenser coils.**

Built-in Reliability

- **High pressure switch and low pressure switch with lockout** protects refrigerant circuit.
- **Adjustable .03 to ten minute delay on make for short cycle protection.**

Ease of Installation

- **Sloped top with flashing** eliminates need of rain hood.
- **Built-in mounting flanges** facilitate installation and minimize chance of water leaks.
- **Supply and return openings** exactly match previous models.
- **Factory installed disconnect** on all units.
- **Single Point Power Entry** complies with latest edition of U.L. Standard 1995.

Rugged Construction

- **Copper tube, aluminum fin** evaporator & condenser coils.
- **Field or factory installed heaters** on discharge side of evaporator coil (optional)
- **Baked on neutral beige finish over galvanized steel** for maximum cabinet life. (Other finishes are available.)

Ease of Service

- **Service access valves** are standard.
- **Standard 2" (50 mm) pleated filter** with a MERV rating of 8 changeable from outside.
- **All major components** are readily accessible.
- **Front Control Panel** allows easy access and complies with NEC clearance codes on redundant side-by-side systems.
- **LEDs indicate operational status** and fault conditions.
- **Foiled backed insulation** on the indoor air path.
- **A minimum position potentiometer that can be adjusted to prevent the economizer damper from closing completely.** This control ensures that whenever the evaporator fan is operating, fresh air is being introduced into the building.

Kim: are these statements valid?

Grilles

For ASDCA36

Supply Grille:

28" x 8" (711mm x 203mm)..... P/N 80675

Return Grille:

20" x 12" (508mm x 356mm)..... P/N 80678

For ASDCA42-48-60-72

Supply Grille:

30" x 10" (762mm x 254mm)..... P/N 80676

Return Grille:

30" x 16" (762mm x 406mm)..... P/N 80679

Factory Installed Accessories

Phase Monitor - Monitors 3Ø power supply and will turn the air conditioner off if power supply is not phased properly. Not required on 1Ø units.

Compressor Sound Jacket - To reduce sound of compressor.

Right & Left Side Compressor Configuration –

The air conditioners can be built with the compressor on the opposite side to facilitate service access when two units are installed side by side. In the 36, the standard location for the compressor is on the right hand side. In the 42-48-60, the standard location for

the compressor is on the left hand side. In the 72, the compressor is accessed from the front of the unit and an opposing configuration is not required.

Hard Start Kit - Used on single phase equipment to give the compressor higher starting torque under low voltage conditions. (Field installed only) (Note: Not recommended for use on scroll compressors.)

Options

Coastal Environment Package – Recommended for units to be installed near an ocean or on seacoast. Includes corrosion resistant fasteners, sealed or partially sealed condenser fan motor, protective coating applied to all exposed internal copper and metal in the in the condenser section and an impregnated polyurethane on the condenser coil and fan blades. See Coastal Environmental Technical Bulletin for more details.

Protective Coil Coatings - Either the condenser or evaporator coil can be coated, however, coating of the evaporator coil is not common. For harsh conditions, e.g., power plants, paper mills or sites where the unit will be exposed to salt water, the coil should be coated. Note: Cooling capacity may be reduced by up to 5% on units with coated coils.

MODEL # - ASDCA48ACA050C-A2-100-VAR

Model Identification

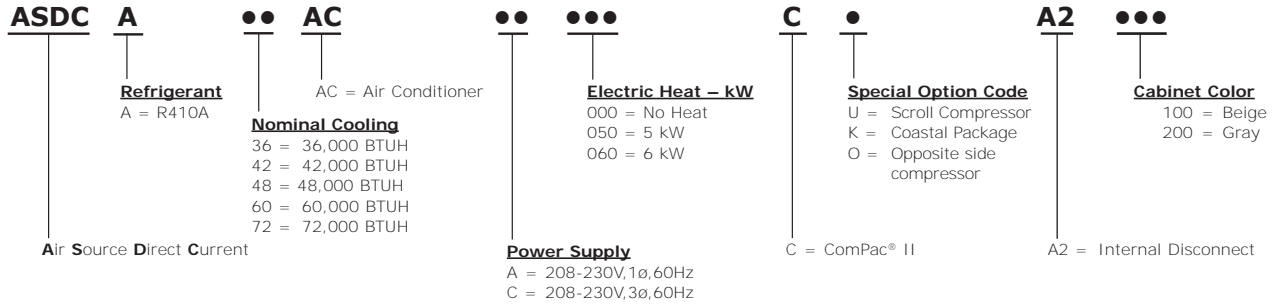

Electrical Characteristics - Compressor, Fan & Blower Motors

BASIC MODEL	COMPRESSOR			OUTDOOR FAN MOTOR				INDOOR BLOWER MOTORS				
	VOLTS / HZ / PH	RLA ¹	LRA ²	VOLTS / HZ / PH	RPM ³	FLA ⁴	HP ⁵	QTY	VDC ⁶	RPM ³	FLA ⁴	HP ⁵
ASDCA36ACA	208/230-60-1	14.7	84.0	208/230-60-1	1075	1.8	1/4	2	48	2070	4.4	1/6
ASDCA42ACA	208/230-60-1	15.7	84.0	208/230-60-1	825	2.8	1/3	2	48	1930	6.0	1/4
ASDCA48ACA	208/230-60-1	18.6	102.0	208/230-60-1	825	2.8	1/3	2	48	1930	6.0	1/4
ASDCA60ACA	208/230-60-1	23.0	130.0	208/230-60-1	825	2.8	1/3	2	48	1930	6.0	1/4
ASDCA72ACA	208/230-60-1	30.1	158.0	208/230-60-1	825	2.9	1/2	2	48	1930	6.0	1/4
ASDCA36ACC	208/230-60-3	13.2	88.0	208/230-60-1	1075	1.8	1/4	2	48	2070	4.4	1/6
ASDCA42ACC	208/230-60-3	13.6	83.1	208/230-60-1	825	2.8	1/3	2	48	1930	6.0	1/4
ASDCA48ACC	208/230-60-3	13.7	83.1	208/230-60-1	825	2.8	1/3	2	48	1930	6.0	1/4
ASDCA60ACC	208/230-60-3	15.6	111.0	208/230-60-1	825	2.8	1/3	2	48	1930	6.0	1/4
ASDCA72ACC	208/230-60-3	22.4	149.0	208/230-60-1	825	2.9	1/2	2	48	1930	6.0	1/4

¹RLA = Rated Load Amps ²LRA = Locked Rotor Amps ³RPM = Revolutions per Minute ⁴FLA = Full Load Amps ⁵HP = Horsepower ⁶VDC = Volts, DC

Summary Electrical Ratings (Wire and Circuit Breaker Sizing)

BASIC MODEL	VOLTAGE PHASE / HZ	000 = None		050 = 5 kw		060 = 6 kw	
		SPPE ³		SPPE ³		SPPE ³	
		MCA ¹	MFS ²	MCA ¹	MFS ²	MCA ¹	MFS ²
ASDCA36ACA	208/230-1-60	24.2	40	26.0	40		
ASDCA42ACA	208/230-1-60	27.6	45	27.6	45		
ASDCA48ACA	208/230-1-60	30.1	50	30.1	50		
ASDCA60ACA	208/230-1-60	35.6	60	35.6	60		
ASDCA72ACA	208/230-1-60	40.5	60	40.5	60		
ASDCA36ACC	208/230-3-60	18.3	30			18.3	30
ASDCA42ACC	208/230-3-60	19.8	30			19.8	30
ASDCA48ACC	208/230-3-60	19.9	30			19.9	30
ASDCA60ACC	208/230-3-60	22.3	35			22.3	35
ASDCA72ACC	208/230-3-60	30.9	50			30.9	50

¹MCA = Minimum Circuit Ampacity (Wiring Size Amps) ²MFS = Maximum Fuse Size ³SPPE = Single Point Power Entry
MCA & MFS are calculated at 230 volts on the ACA & ACC models. This chart should only be used as a guideline for estimating conductor size and overcurrent protection. For the requirements of specific units, always refer to the data label on the unit.

Unit Load Amps

BASIC MODEL NUMBER	VOLTAGE PHASE / HZ	CURRENT LOAD (MOTORS)		LOAD OF RESISTIVE HEATING - ELEMENTS ONLY (AMPS)	
		Compressor & Outdoor Fan	Indoor Blower	TOTAL MAXIMUM HEATING AMPS (VAC)	
				ALL HEATING ELEMENTS ARE ON A SEPARATE CIRCUIT	
VAC Amps	DC Amps	05 kW	06 kW		
ASDCA36ACA	208/230-1-60	19.7	8.8	20.8	
ASDCA42ACA	208/230-1-60	22.6	12.0	20.8	
ASDCA48ACA	208/230-1-60	24.6	12.0	20.8	
ASDCA60ACA	208/230-1-60	29.0	12.0	20.8	
ASDCA72ACA	208/230-1-60	33.0	12.0	20.8	
ASDCA36ACC	208/230-3-60	15.0	8.8		14.4
ASDCA42ACC	208/230-3-60	16.4	12.0		14.4
ASDCA48ACC	208/230-3-60	16.5	12.0		14.4
ASDCA60ACC	208/230-3-60	18.4	12.0		14.4
ASDCA72ACC	208/230-3-60	25.3	12.0		14.4

Heating kW is rated at 240 volts Total heating and cooling amps includes all VAC motors.
Loads are not equally balanced on each phase and values shown are maximum phase loads. Three phase models contain single phase motor loads.
Derate heater output by 25% for operation at 208 volts.

Dimensional Data - ASDCA36

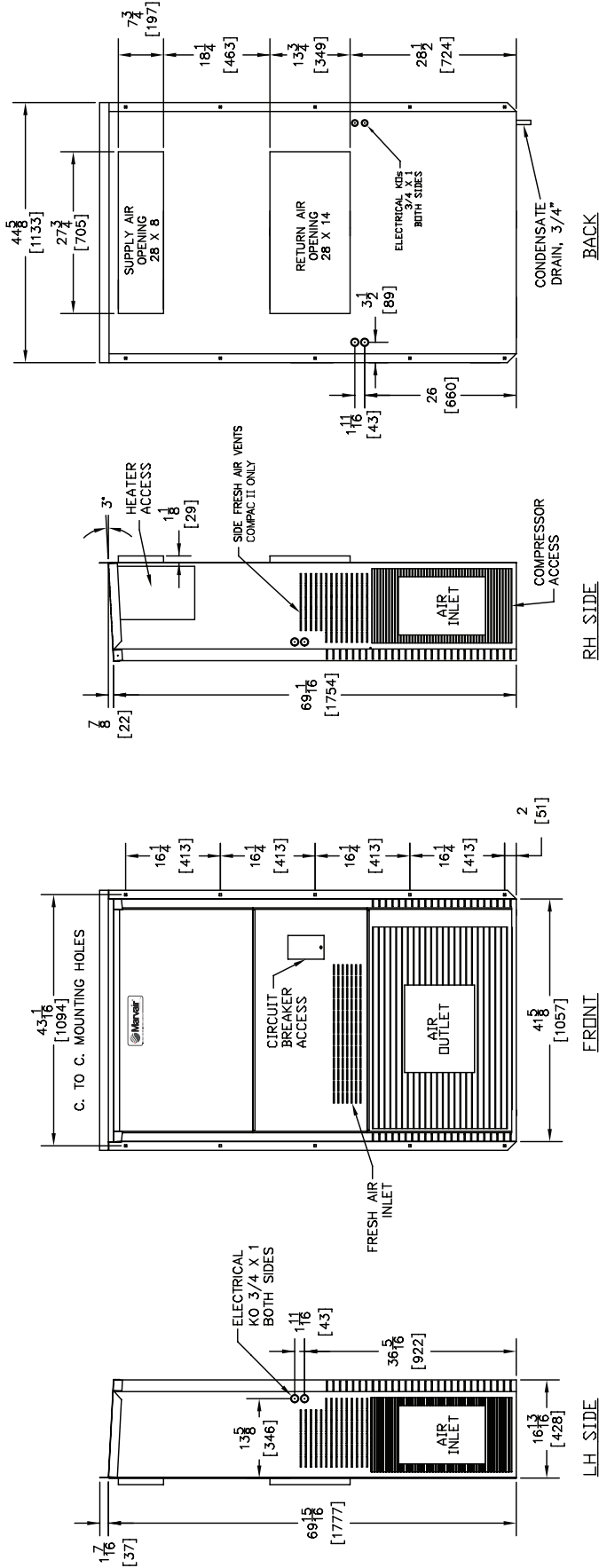

Shipping Weight (pounds/kilograms)

ASDCA36	LBS/KGS
COMPAC II	410/186.4

Filter Size

ASDCA36	INCHES	MILLIMETERS	PART NUMBER	FILTERS PER UNIT	MERV RATING
RETURN AIR FILTER	30 x 16 x 2	762 x 406 x 51	92486	1	8

BOTTOM MOUNTING BRACKET

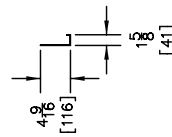
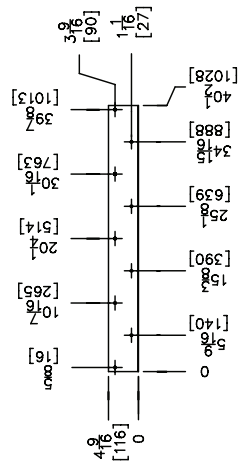

Dimensional Data - ASDCA42-48-60

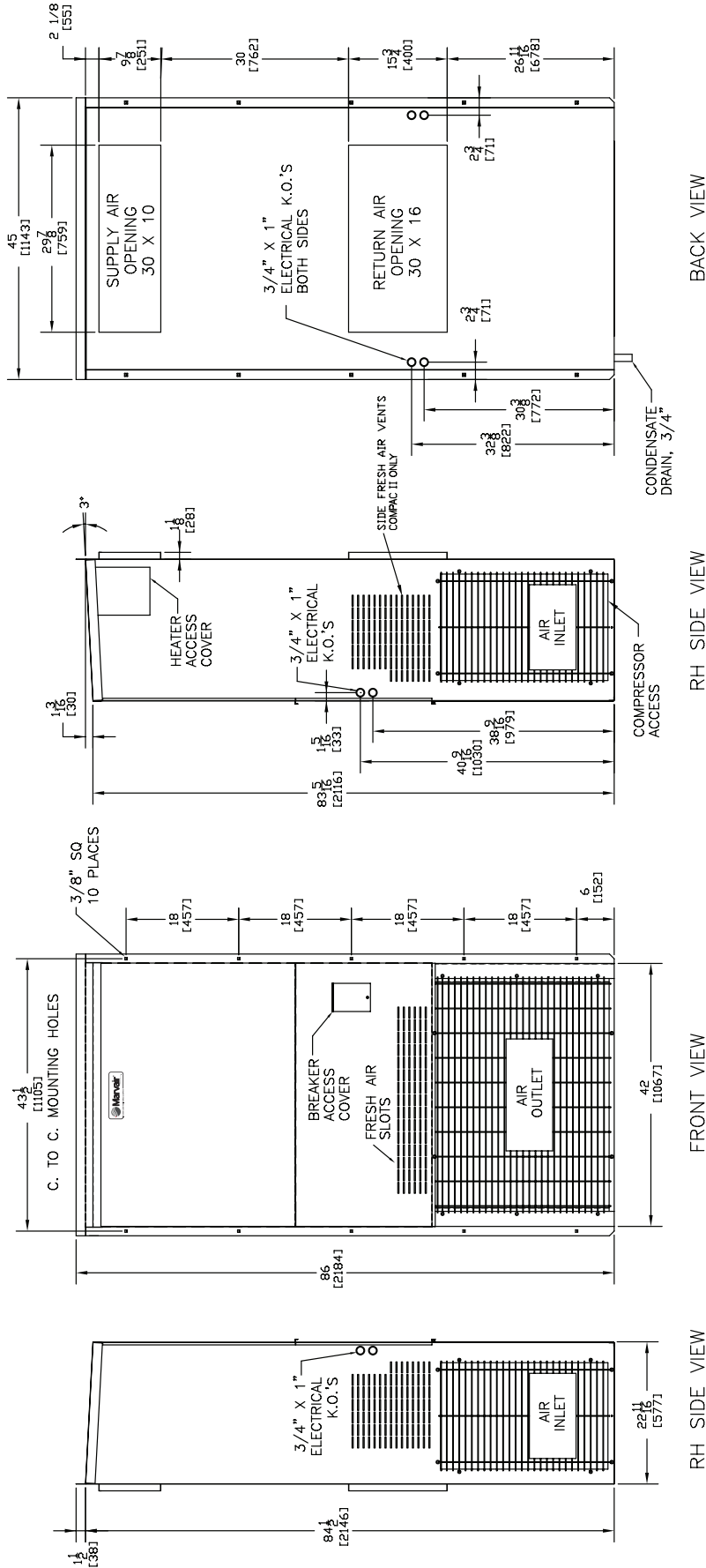

Shipping Weight (pounds/kilograms)

ASDCA42-48-60	LBS/KGS
COMPAC II	590/268

Filter Size

ASDCA42-48-60	INCHES	MILLIMETERS	PART NUMBER	FILTERS PER UNIT	MERV RATING
RETURN AIR FILTER	36 1/2 x 22 x 2	927 x 559 x 51	80162	1	8

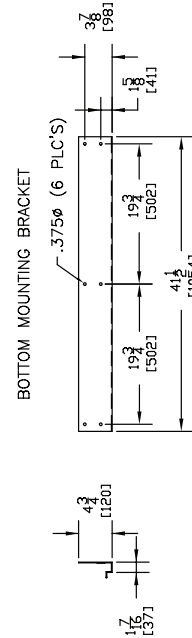

Dimensional Data - ASDCA72

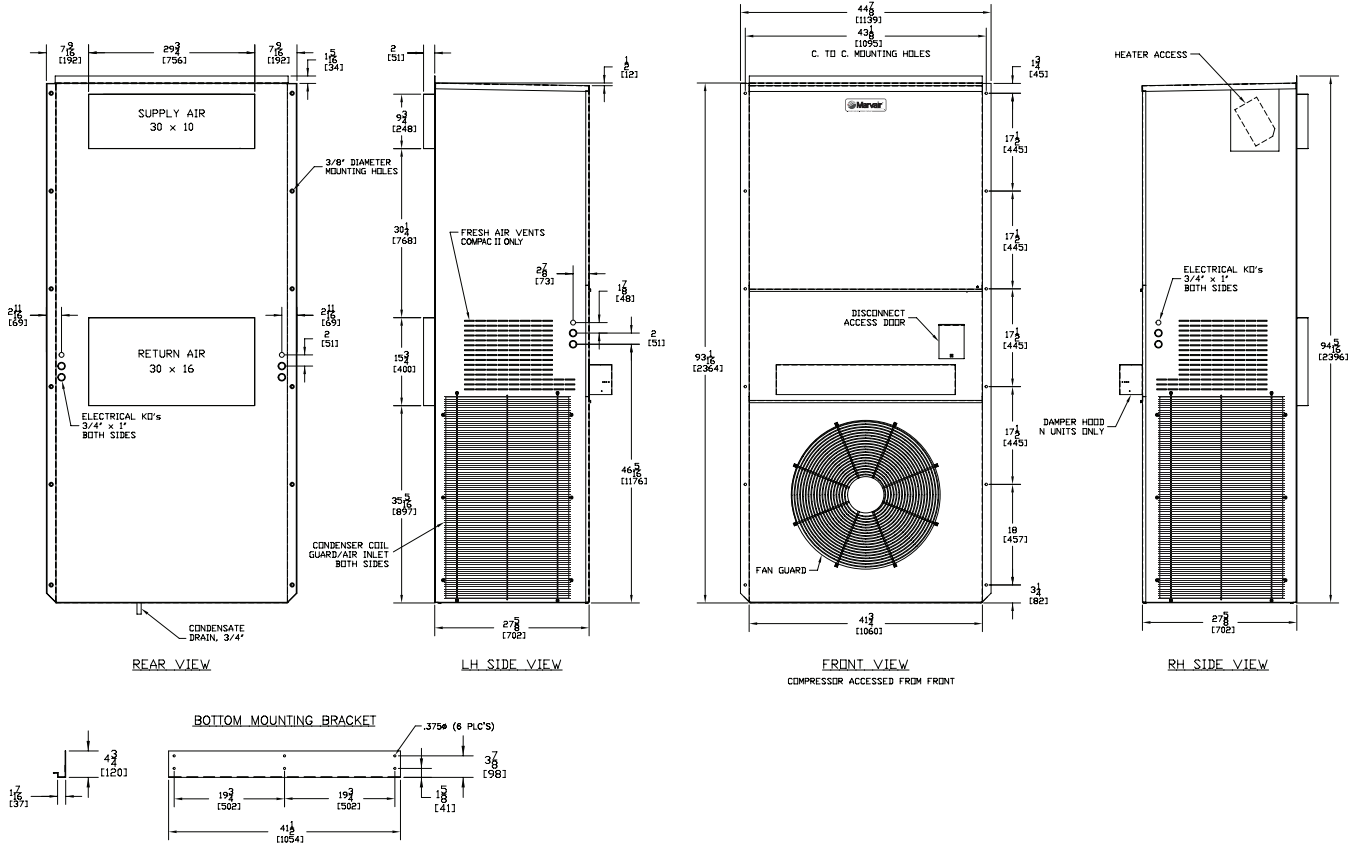

Shipping Weight (pounds/kilograms)

ASDCA72	LBS/KGS
COMPAC II	640/291

Filter Size

ASDCA72	INCHES	MILLIMETERS	PART NUMBER	FILTERS PER UNIT	MERV RATING
RETURN AIR FILTER	18 x 24 x 2	457 x 610 x 51	TBD	2	8



Please consult the Marvair® website at www.marvair.com for the latest product literature. Detailed dimensional data is available upon request. A complete warranty statement can be found in each product's Installation/Operation Manual, on our website or by contacting Marvair at 229-273-3636. As part of the Marvair continuous improvement program, specifications are subject to change without notice.



P.O. Box 400 • Cordele, GA 31010
 156 Seedling Drive • Cordele, GA 31015
 Ph: 229-273-3636 • Fax: 229-273-5154
 Email: marvair@airxcel.com • Internet: www.marvair.com



Supplement to the ComPac Product Manual for the ASDC air conditioners

This supplement to the ComPac Product Manual describes the 48 VDC wiring, the connection of the Ethernet cable (page 2) and the CoolLinks™ Operator Interface Instructions (page 3) for the ASDCA air conditioners. These air conditioners require a 48 Volt DC power to operate the evaporator air movers and the free cooling damper motor.

48 VDC wiring

1. If the air conditioners are powered, remove AC **and** DC power to the air conditioners by switching the breakers **in the shelter** to the OFF position.
2. Size a 2 conductor wire cable per NEC standard taking into account the ampacity of the DC circuit listed on the rating plate and the location of the power supply. Connect the properly sized cable between a DC breaker in the shelter and the DC breaker in the air conditioner. The DC breaker in the air conditioner is located on the right side of the bank of breakers.
3. Turn on the DC breaker in the shelter.
4. Verify the polarity and the voltage to make sure the polarity is correct and that there is 48 VDC at the breaker in the air conditioner. If the polarity is not correct, switch the wires.
5. Turn on the DC breaker in the air conditioner.
(See photos on following page.)

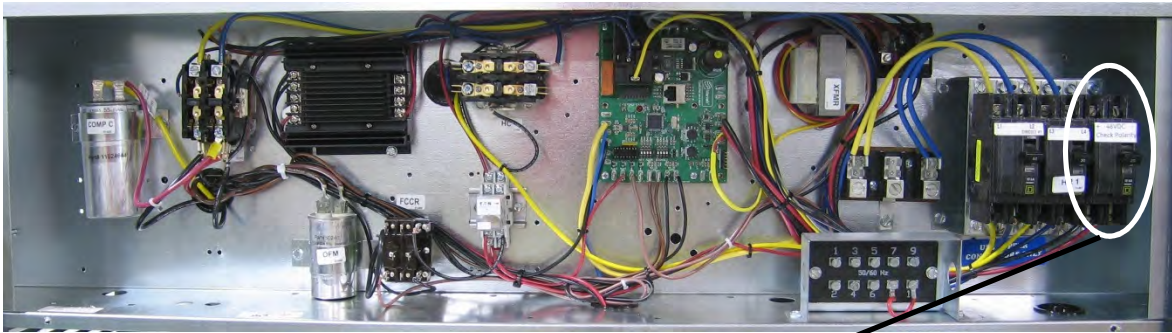

Connection of PLC controller board in shelter to CoolLinks™ board in the air conditioner

Route a standard Cat 5e Ethernet cable from the PC board in the air conditioner to the PLC controller in the shelter. If the cable is routed through the air stream, it must be plenum rated. When the PLC is configured, the air conditioners will be designated as AC #1 and AC#2.

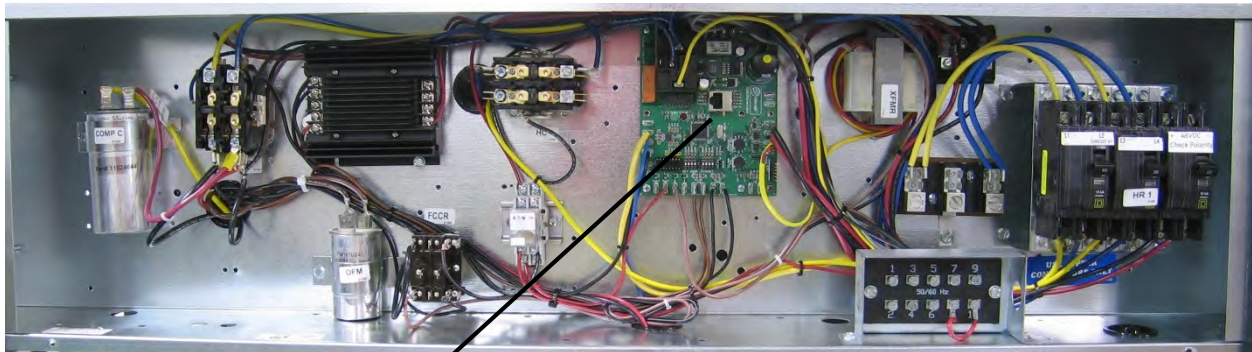

CoolLinks Ethernet jack



Operator Interface Instructions

System Status

The main screen displays the status of the Marvair CoolLinks system and the two Marvair HVAC units. Standing inside the shelter facing the HVAC return air vents, unit 1 is the left-hand unit and unit 2 is the right-hand unit. The fields on the status screen are as follows:

Indoor Temperature:	Indoor temperature from the temperature sensor mounted on the wall between the HVAC return air grilles. This sensor controls the enabling/disabling of the cooling/heating.
IBM Pushbutton:	Indicates the status of the Indoor Blower Motor (IBM) as Running or Stopped. If the blower motor is not under automatic control, pressing the pushbutton will turn the motor on and off. Press once to turn on and press again to turn off. The motor is under automatic control whenever the HVAC unit is the lead unit, during cooling post-purge, free-air operation, and emergency ventilation.
Unit Status Panel:	Indicates the status of the HVAC unit as follows: <ul style="list-style-type: none">• Lead Yes: unit is lead unit, No: unit is lag unit• Cool Yes: unit is cooling, No: unit is not cooling• Heat Yes: unit is heating, No: unit is not heating• Filter Ok: filter is good, Maint: filter is blocked• Comm Yes: PLC comms active, No: PLC comms fault
Lead Swap Pushbutton:	Swap the lead and lag unit. Note that if the lag unit is in lockout or has a comms fault, the system will not swap. If the lead unit experiences a lockout or



comms failure, the system will automatically swap to the lag unit.

Comfort Mode Pushbutton: Drop the first-stage cooling set point to 75°F to allow a service technician to work comfortably inside the shelter. After one hour the set point will return to its previous value. Comfort mode is also cancelled if the technician enters a new first-stage cooling set point.

Reset Lockout Pushbutton: Resets the lockout condition on whichever unit is in lockout. Note that a call for cooling must be active before the lockout can be reset.

Outdoor Air: Outside air temperature (°F).

Humidity: Outside air relative humidity (%).

Dew Point: Dew point temperature (°F). When the calculated dew point (based on outside air temperature and relative humidity) is below the maximum dew point temperature and the free-air enable temperature, and the outside air temperature is below the indoor air temperature, then enable free-air cooling.

Alarm Message: Active unit alarms are displayed in the alarm message window between the IBM (Indoor blower Motor) pushbutton and the unit status panel. If multiple alarms are present the system scrolls through the active alarms with each alarm displayed for five seconds. If no alarms are present, the message window is blank. Thirteen possible alarm messages may be displayed:

- High Pressure Switch Alarm
- Low Pressure Switch Alarm
- High Pressure Switch Lockout Alarm
- Low Pressure Switch Lockout Alarm
- 1st High Indoor Temperature Alarm (> 85°F)



- 2nd High Indoor Temperature Alarm (> 90°F)
- Low Indoor Temperature Alarm (< 45°F)
- Landline Power Alarm
- Damper Alarm
- Smoke Alarm
- Generator Running
- Hydrogen Alarm
- Communications Alarm

The main screen with each of the operator/display fields is presented below. Note that the six function keys at the bottom of the screen are not currently assigned and have no effect on the operation of the Marvair CoolLinks system.

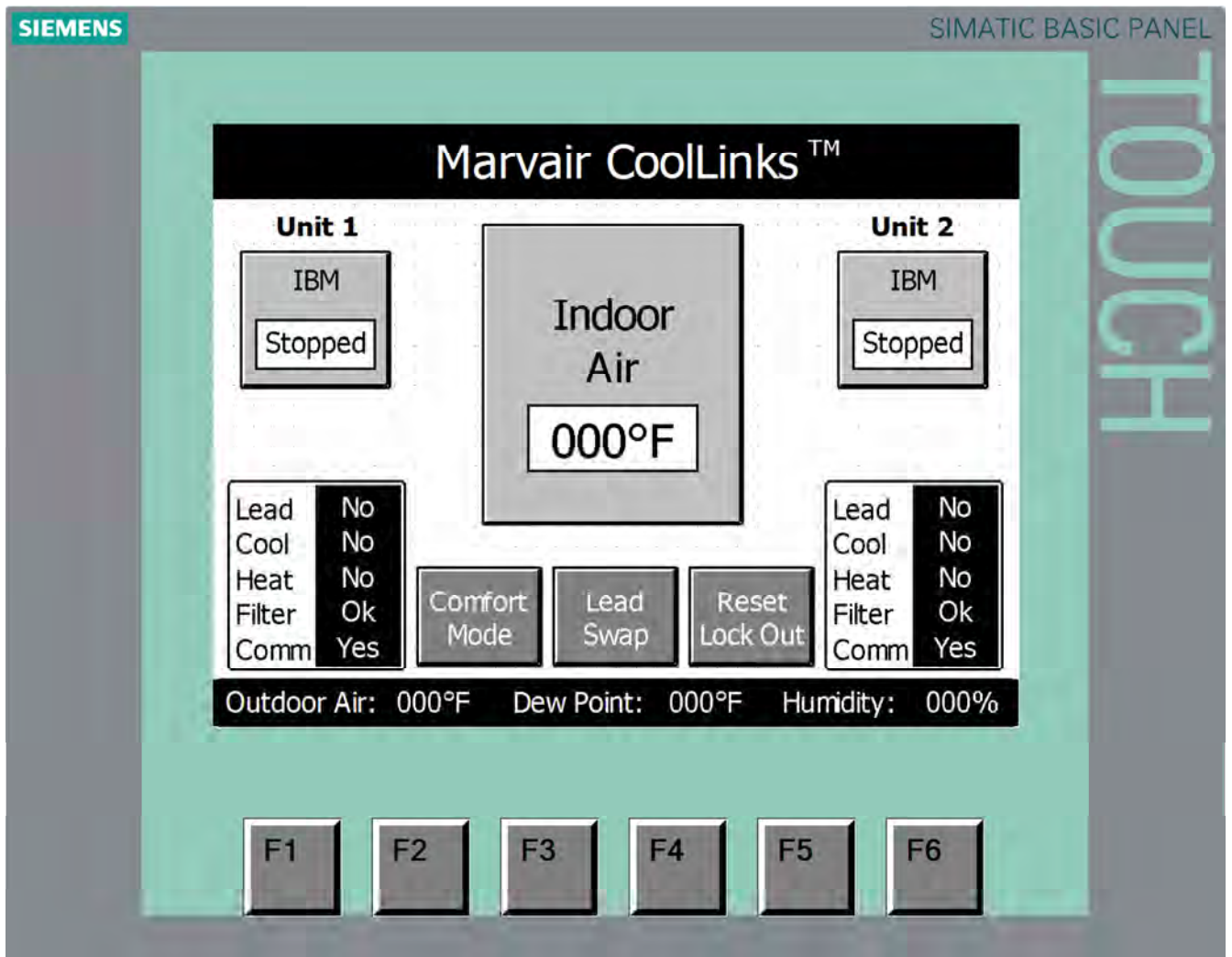



Changing Set Points

Set points control the cooling and heating operation of the Marvair CoolLinks system. Basically, there are two groups of set points, cooling first and second stage set points, and heating first and second stage set points. The minimum set point for cooling is 50°F and the maximum set point for heating is 90°F. To access these set points, simply touch the top or bottom of the Indoor Temperature display. This will then enable the set point control panel. If a new set point value is not entered within ten seconds, the display will revert back to the Indoor Temperature display. From the set point control panel, alter the set points as follows:

Cooling First Stage:

Press the Cooling push-button then press the 1st Stage push-button. Both push buttons will turn dark gray with white text and the current cooling first-stage set point value will be displayed. Next, press the set point value to display the numeric entry screen and enter the desired set point. The system will now enable cooling whenever the indoor temperature is 1° F above the set point and disable cooling when the indoor temperature drops to 2° F below the set point.

Cooling Second Stage:

Press the Cooling push-button then press the 2nd Stage push-button. Both push buttons will turn dark gray with white text and the current cooling second-stage set point value will be displayed. Next, press the set point value to display the numeric entry screen and enter the differential set point. The system will now enable second-stage cooling whenever the indoor temperature is 1° F higher than the first-stage cooling set point plus the second stage cooling differential and disable second-stage cooling when the indoor temperature drops to 2° F below the first-stage set point. It is strongly recommend that the second-stage cooling differential be set to a minimum of 5° F to allow the first-stage cooling time to operate fully and to prevent short-cycling of the second unit.



Cooling Example:

First-Stage Set Point: 78°F

Second-Stage Differential: 5°F

First-stage cooling will start when the indoor temperature reaches 79°F (set point + 1°F) and will stop when the indoor temperature reaches 76°F (set point – 2°F).

Second-stage cooling will start when the indoor temperature reaches 84°F (set point + 1°F + 5°F) and will stop when the indoor temperature reaches 76°F (set point – 2°F).

Note that once first-stage cooling is enabled, the unit will run for at least **five minutes** even if the indoor temperature reaches the disable temperature. This is to prevent short-cycling of the unit and to allow the compressor sufficient time to remove moisture from the air as well cool the shelter.

Heating First Stage:

Press the Heating push-button then press the 1st Stage push-button. Both push buttons will turn dark gray with white text and the current heating first-stage set point value will be displayed. Next, press the set point value to display the numeric entry screen and enter the desired set point. The system will now enable heating whenever the indoor temperature is 1°F below the set point and disable heating when the indoor temperature rises to 1° F above the set point.

Heating Second Stage:

Press the Heating push-button then press the 2nd Stage push-button. Both push buttons will turn dark gray with white text and the current heating second-stage set point value will be displayed. Next, press the set point value to display the numeric entry screen and enter the differential set point. The system will now enable second-stage heating whenever the indoor temperature is 1° F lower than the first-stage heating set point minus the second stage heating differential and disable second-stage heating when the indoor temperature rises to 1° F above the first-stage set point. It is strongly recommend that the second-stage heating differential be set to a minimum of



two degrees F to allow the first-stage heating time to operate fully and to prevent short-cycling of the second unit.

Heating Example:

First-Stage Set Point: 60°F

Second-Stage Differential: 2°F

First-stage heating will start when the indoor temperature reaches 59°F (set point – 1°F) and will stop when the indoor temperature reaches 61°F (set point + 1°F).

Second-stage heating will start when the indoor temperature reaches 57°F (set point – 1° - 2°F) and will stop when the indoor temperature reaches 61°F (set point + 1°F).

The main screen with the set point control panel is presented below. Note that if the cooling and heating temperature set points overlap, the system will only allow cooling to be active. As with the status screen, the six function keys at the bottom of the screen are not currently assigned and have no effect on the operation of the Marvair CoolLinks system.

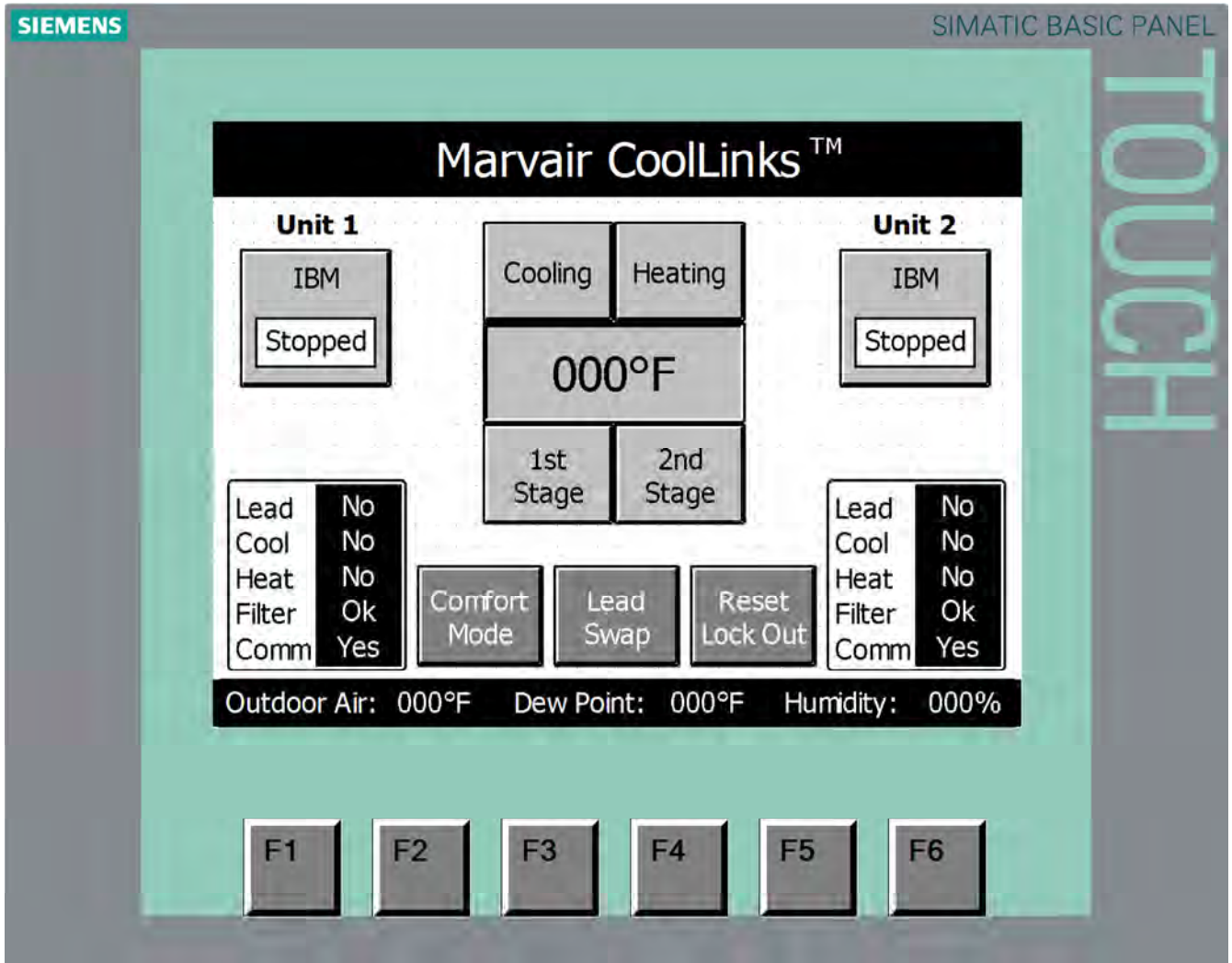

DC Free-Air Cooling

When the outside temperature and humidity are below acceptable limits, mechanical cooling is disabled and outside air is introduced to cool the shelter. The position of the damper is first opened to 100% then regulated to maintain a mixed air temperature of 55°F. This set point is user-selectable on the CoolLinks HVAC board for 55°, 57°, 59°, or 61°F. Both the damper and the Indoor Blower Motor are powered by 48 VDC. Every twenty-four hours, the damper is opened to 25% to verify the operation of damper motor, damper fault switch, and damper actuator linkage.



Emergency Ventilation

The Marvair CoolLinks system will enable emergency ventilation if landline power is lost or if both HVAC units are in lockout. In this situation, the system will fully open the damper and run the Indoor Blower Motor on each HVAC unit. The system will also try to modulate the damper position to maintain a mixed air temperature of 55°F).

Smoke Detection

If the smoke sensor input to the CoolLinks system is active, the Compressor, Heater, and Indoor Blower Motor on both HVAC units will be shut down and the damper will be fully closed. This is to halt the flow of air within the shelter.

Hydrogen Detection

If the hydrogen sensor input to the CoolLinks system is active, the damper(s) on units that are not currently mechanically cooling will be fully opened and the Indoor Blower Motor(s) will be turned on. The intention here is to expel noxious gases and to introduce outside air into the shelter.

Generator Running

If the generator running input to the CoolLinks system is active, only one HVAC unit will be permitted to run mechanical cooling. As the generator is sized to run only one HVAC unit, this ensures that the generator load is not exceeded.

Note: When in generator run mode, the HVAC unit is **not** allowed to operate in the DC Free-Air Cooling mode. This prevents "wet stacking" of the generator because the engine would be running at a small percentage of its capacity.

STANDBY POWER RATING

35 kW, 44 kVA, 60 Hz

PRIME POWER RATING*

32 kW, 39 kVA, 60 Hz

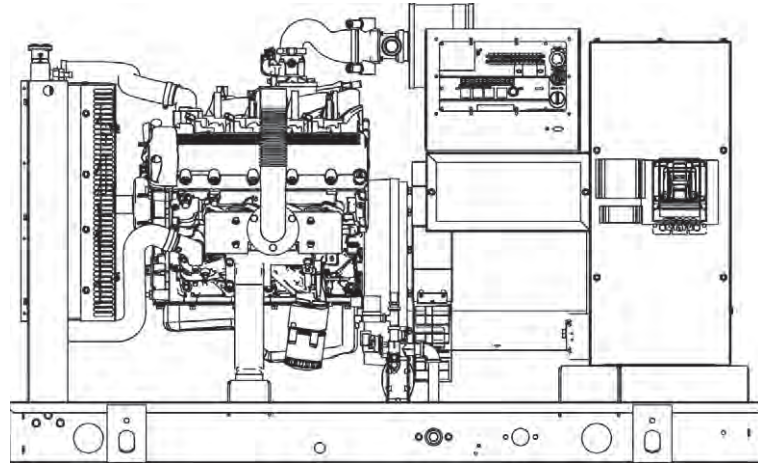

*Built in the USA using domestic and foreign parts

*EPA Certified Prime ratings are not available in the U.S. or its Territories.

Image used for illustration purposes only

CODES AND STANDARDS

Generac products are designed to the following standards:

 UL2200, UL508, UL142, UL498

 NFPA70, 99, 110, 37

 NEC700, 701, 702, 708

 ISO9001, 8528, 3046, 7637, Pluses #2b, 4

 NEMA ICS10, MG1, 250, ICS6, AB1

 ANSI C62.41
American National Standards Institute

  IBC 2009, CBC 2010, IBC 2012, ASCE 7-05, ASCE 7-10, ICC-ES AC-156 (2012)

POWERING AHEAD

For over 50 years, Generac has led the industry with innovative design and superior manufacturing.

Generac ensures superior quality by designing and manufacturing most of its generator components, including alternators, enclosures and base tanks, control systems and communications software.

Generac's gensets utilize a wide variety of options, configurations and arrangements, allowing us to meet the standby power needs of practically every application.

Generac searched globally to ensure the most reliable engines power our generators. We choose only engines that have already been proven in heavy-duty industrial application under adverse conditions.

Generac is committed to ensuring our customers' service support continues after their generator purchase.

STANDARD FEATURES

ENGINE SYSTEM

General

- Oil Drain Extension
- Air Cleaner
- Fan Guard
- Stainless Steel flexible exhaust connection
- Factory Filled Oil & Coolant
- Radiator Duct Adapter (open set only)
- Critical Exhaust Silencer (enclosed only)

Fuel System

- Flexible fuel line NPT Connection
- Primary and secondary fuel shutoff

Cooling System

- Closed Coolant Recovery System
- UV/Ozone resistant hoses
- Factory-Installed Radiator
- 50/50 Ethylene glycol antifreeze
- Radiator drain extension

Engine Electrical System

- Battery charging alternator
- Battery cables
- Battery tray
- Rubber-booted engine electrical connections
- Solenoid activated starter motor

ALTERNATOR SYSTEM

- UL2200 Genprotect™
- Class H insulation material
- 2/3 Pitch
- Skewed Stator
- Brushless Excitation
- Sealed Bearings
- Amortisseur winding
- Full load capacity alternator

GENERATOR SET

- Internal Genset Vibration Isolation
- Separation of circuits - high/low voltage
- Separation of circuits - multiple breakers
- Wrapped Exhaust Piping
- Standard Factory Testing
- 2 Year Limited Warranty (Standby rated Units)
- 1 Year Warranty (Prime rated units)
- Silencer mounted in the discharge hood (enclosed only)

ENCLOSURE (IF SELECTED)

- Rust-proof fasteners with nylon washers to protect finish
- High performance sound-absorbing material (L1 & L2)
- Gasketed doors
- Stamped air-intake louvers
- Air discharge hoods for radiator-upward pointing
- Stainless steel lift off door hinges
- Stainless steel lockable handles
- Rhino Coat™ - Textured polyester powder coat

CONTROL SYSTEM



Control Panel

- Digital H Control Panel - Dual 4x20 Display
- Programmable Crank Limiter
- 7-Day Programmable Exerciser
- Special Applications Programmable PLC
- RS-232/485
- All-Phase Sensing DVR
- Full System Status
- Utility Monitoring
- Low Fuel Pressure Indication
- 2-Wire Start Compatible
- Power Output (kW)
- Power Factor
- kW Hours, Total & Last Run

- Real/Reactive/Apparent Power
- All Phase AC Voltage
- All Phase Currents
- Oil Pressure
- Coolant Temperature
- Coolant Level
- Engine Speed
- Battery Voltage
- Frequency
- Date/Time Fault History (Event Log)
- Isochronous Governor Control
- Waterproof/sealed Connectors
- Audible Alarms and Shutdowns
- Not in Auto (Flashing Light)
- Auto/Off/Manual Switch
- E-Stop (Red Mushroom-Type)
- NFPA110 Level I and II (Programmable)
- Customizable Alarms, Warnings, and Events
- Modbus protocol
- Predictive Maintenance algorithm
- Sealed Boards
- Password parameter adjustment protection

- Single point ground
- 15 channel data logging
- 0.2 msec high speed data logging
- Alarm information automatically comes up on the display

Alarms

- Oil Pressure (Pre-programmable Low Pressure Shutdown)
- Coolant Temperature (Pre-programmed High Temp Shutdown)
- Coolant Level (Pre-programmed Low Level Shutdown)
- Low Fuel Pressure Alarm
- Engine Speed (Pre-programmed Over speed Shutdown)
- Battery Voltage Warning
- Alarms & warnings time and date stamped
- Alarms & warnings for transient and steady state conditions
- Snap shots of key operation parameters during alarms & warnings
- Alarms and warnings spelled out (no alarm codes)

CONFIGURABLE OPTIONS

ENGINE SYSTEM

General

- Engine Block Heater
- Oil Heater
- Air Filter Restriction Indicator
- Stone Guard (Open Set Only)
- Critical Exhaust Silencer (Open Set Only / Standard on Ultra Low Emissions Option)

Fuel Electrical System

- 10A & 2.5A UL battery charger
- Battery Warmer

ALTERNATOR SYSTEM

- Alternator Upsizing
- Anti-Condensation Heater
- Tropical Coating
- Permanent Magnet Excitation

CIRCUIT BREAKER OPTIONS

- Main Line Circuit Breaker
- 2nd Main Line Circuit Breaker
- Shunt Trip and Auxiliary Contact
- Electronic Trip Breaker

ENGINEERED OPTIONS

ENGINE SYSTEM

- Fluid containment Pans
- Coolant heater ball valves

ALTERNATOR SYSTEM

- 3rd Breaker Systems

CONTROL SYSTEM

- Spare inputs (x4) / outputs (x4) - H Panel Only
- Battery Disconnect Switch

GENERATOR SET

- Gen-Link Communications Software (English Only)
- Extended Factory Testing (3 Phase Only)
- IBC Seismic Certification
- 8 Position Load Center
- 2 Year Extended Warranty
- 5 Year Warranty
- 5 Year Extended Warranty

ENCLOSURE

- Standard Enclosure
- Level 1 Sound Attenuation
- Level 2 Sound Attenuation
- Steel Enclosure
- Aluminum Enclosure
- 150 MPH Wind Kit
- 12 VDC Enclosure Lighting Kit
- 120 VAC Enclosure Lighting Kit
- AC/DC Enclosure Lighting Kit
- Door Alarm Switch

GENERATOR SET

- Special Testing
- Battery Box

ENCLOSURE

- Motorized Dampers
- Enclosure Ambient Heaters

CONTROL SYSTEM

- 21-Light Remote Annunciator
- Remote Relay Board (8 or 16)
- Oil Temperature Sender with Indication Alarm
- Remote E-Stop (Break Glass-Type, Surface Mount)
- Remote E-Stop (Red Mushroom-Type, Surface Mount)
- Remote E-Stop (Red Mushroom-Type, Flush Mount)
- Remote Communication - Bridge
- Remote Communication - Ethernet
- 10A Run Relay
- Ground Fault Indication and Protection Functions

RATING DEFINITIONS

Standby - Applicable for a varying emergency load for the duration of a utility power outage with no overload capability.

Prime - Applicable for supplying power to a varying load in lieu of utility for an unlimited amount of running time. A 10% overload capacity is available for 1 out of every 12 hours. The Prime Power option is only available on International applications. Power ratings in accordance with ISO 8528-1, Second Edition

APPLICATION AND ENGINEERING DATA

ENGINE SPECIFICATIONS

General

Make	Generac
Cylinder #	8
Type	V
Displacement - L (cu In)	5.4L (329.53)
Bore - mm (in)	90.17 (3.55)
Stroke - mm (in)	105.92 (4.17)
Compression Ratio	9:1
Intake Air Method	Naturally Aspirated
Number of Main Bearings	4
Connecting Rods	Forged
Cylinder Head	Aluminum
Cylinder Liners	No
Ignition	Single Fire
Piston Type	Aluminum Alloy
Crankshaft Type	Nodular Iron
Lifter Type	Hydraulic
Intake Valve Material	Steel Alloy
Exhaust Valve Material	Hardened Steel
Hardened Valve Seats	Yes

Engine Governing

Governor	Electronic
Frequency Regulation (Steady State)	±0.25%

Lubrication System

Oil Pump Type	Gear
Oil Filter Type	Full-flow sping-on cartridge
Crankcase Capacity - L (qts)	5.7 (6)

Cooling System

Cooling System Type	Pressurized Closed Recovery
Water Pump Flow -gal/min (l/min)	38 (144)
Fan Type	Pusher
Fan Speed (rpm)	2143
Fan Diameter mm (in)	508 (20)
Coolant Heater Wattage	1500
Coolant Heater Standard Voltage	120 V

Fuel System

Fuel Type	Natural Gas, Propane Vapor
Carburetor	Down Draft
Secondary Fuel Regulator	Standard
Fuel Shut Off Solenoid	Standard
Operating Fuel Pressure	7" - 11" H ₂ O

Engine Electrical System

System Voltage	12 VDC
Battery Charging Alternator	Standard
Battery Size	See Battery Index 0161970SBY
Battery Voltage	12 VDC
Ground Polarity	Negative

ALTERNATOR SPECIFICATIONS

Standard Model	390mm
Poles	4
Field Type	Revolving
Insulation Class - Rotor	H
Insulation Class - Stator	H
Total Harmonic Distortion	<5%
Telephone Interference Factor (TIF)	<50

Standard Excitation	Brushless
Bearings	Sealed Ball
Coupling	Flexible Disc
Prototype Short Circuit Test	Yes
Voltage Regulator Type	Full Digital
Number of Sensed Phases	All
Regulation Accuracy (Steady State)	±0.25%

OPERATING DATA

POWER RATINGS

		Natural Gas	Propane Vapor
Single-Phase 120/240 VAC @1.0pf	35 kW	Amps: 146	Amps: 146
Three-Phase 120/208 VAC @0.8pf	35 kW	Amps: 121	Amps: 121
Three-Phase 120/240 VAC @0.8pf	35 kW	Amps: 105	Amps: 105
Three-Phase 277/480 VAC @0.8pf	35 kW	Amps: 53	Amps: 53
Three-Phase 347/600 VAC @0.8pf	35 kW	Amps: 42	Amps: 42

STARTING CAPABILITIES (sKVA)

sKVA vs. Voltage Dip

	kW	480 VAC						208/240 VAC					
		10%	15%	20%	25%	30%	35%	10%	15%	20%	25%	30%	35%
Standard	35	24	36	48	60	72	84	18	27	36	45	54	63
Upsize 1	40	27	41	54	68	81	95	20	31	41	51	61	71
Upsize 2	50	34	52	69	86	103	120	26	39	52	65	77	90
Upsize 3	60	42	63	83	104	125	146	32	47	62	78	94	110

FUEL CONSUMPTION RATES*

Natural Gas - ft ³ /hr (m ³ /hr)			Propane Vapor - ft ³ /hr (m ³ /hr)		
Percent Load	Standby		Percent Load	Standby	
25%	239 (6.8)		25%	79.7 (2.3)	
50%	409 (11.6)		50%	136.6 (3.9)	
75%	553 (15.7)		75%	184.4 (5.2)	
100%	682 (19.3)		100%	227.7 (6.4)	

* Fuel supply installation must accommodate fuel consumption rates at 100% load.

COOLING

		Standby
Air Flow (inlet air combustion and radiator)	ft ³ /min(m ³ /min)	2460 (69.7)
Coolant Flow per Minute	gal/min (l/min)	38 (144)
Coolant System Capacity	gal (l)	3 (11.36)
Heat Rejection to Coolant	BTU/hr	144,000
Max. Operating Air Temp on Radiator	°F (°C)	122 (50)
Max. Operating Ambient Temperature (before derate)	°F (°C)	110 (43.3)
Maximum Radiator Backpressure	in H ₂ O	0.5

COMBUSTION AIR REQUIREMENT

	Standby
Flow at Rated Power cfm (m ³ /min)	87 (2.5)

ENGINE

		Standby
Rated Engine Speed	rpm	1800
Horsepower at Rated kW**	hp	54
Piston Speed	ft/min	1251
BMEP	psi	72

EXHAUST

		Standby
Exhaust Flow (Rated Output)	cfm (m ³ /min)	260 (7.4)
Max. Backpressure (Post Turbo)	inHg (Kpa)	1.5 (5.1)
Exhaust Temp (Rated Output - post silencer)	°F (°C)	900 (482)
Exhaust Outlet Size (Open Set)	mm (in)	63.5 (2.5)

** Refer to "Emissions Data Sheet" for maximum bHP for EPA and SCAQMD permitting purposes.

Deration – Operational characteristics consider maximum ambient conditions. Derate factors may apply under atypical site conditions. Please consult a Generac Power Systems Industrial Dealer for additional details. All performance ratings in accordance with ISO3046, BS5514, ISO8528 and DIN6271 standards.

DIMENSIONS AND WEIGHTS

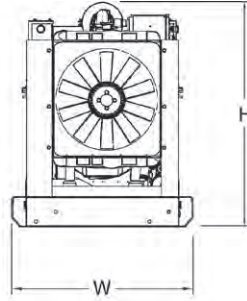
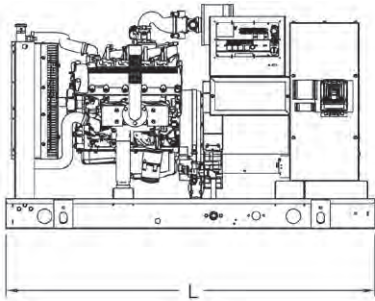

OPEN SET (Includes Exhaust Flex)

L x W x H in (mm)	76 (1930) x 37.4 (949.9) x 46 (1176)
Weight lbs (kg)	2199 (997)

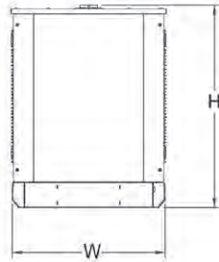
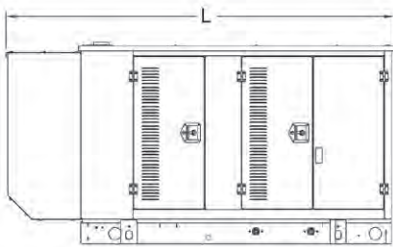

STANDARD ENCLOSURE

L x W x H in (mm)	94.8 (2408.9) x 38 (965.1) x 49.5 (1258.1)
Weight lbs (kg)	Steel: 2639 (1197) Aluminum: 2417 (1096)

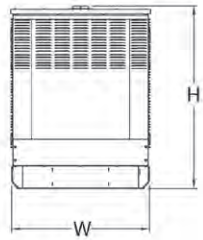
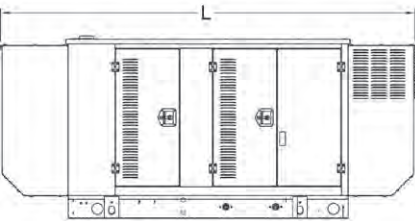

LEVEL 1 ACOUSTIC ENCLOSURE

L x W x H in (mm)	112.5 (2857.1) x 38 (965.1) x 49.5 (1258.1)
Weight lbs (kg)	Steel: 2719 (1233) Aluminum: 2451 (1112)

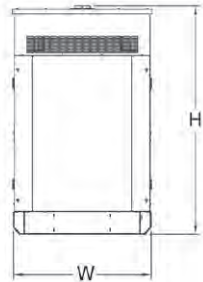
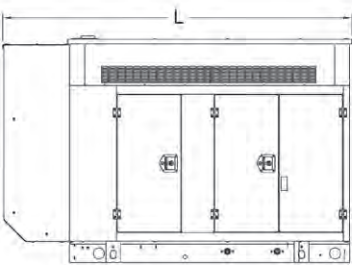

LEVEL 2 ACOUSTIC ENCLOSURE

L x W x H in (mm)	94.8 (2408.9) x 38 (965.1) x 62 (1573.9)
Weight lbs (kg)	Steel: 2871 (1302) Aluminum: 2517 (1142)

YOUR FACTORY RECOGNIZED GENERAC INDUSTRIAL DEALER

Specification characteristics may change without notice. Please consult a Generac Power Systems Industrial Dealer for detailed installation drawings.

LEVEL 2 ACOUSTIC ENCLOSURE SG35 5.4L

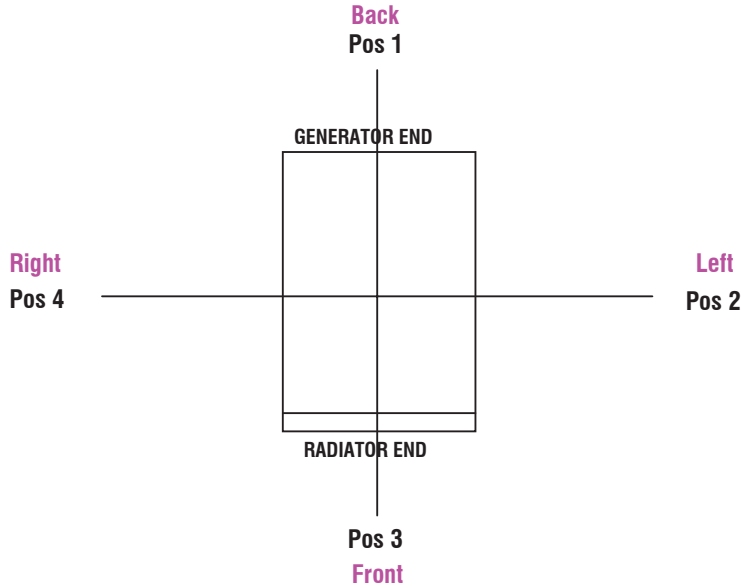

Measured Sound Levels - 60 Hz

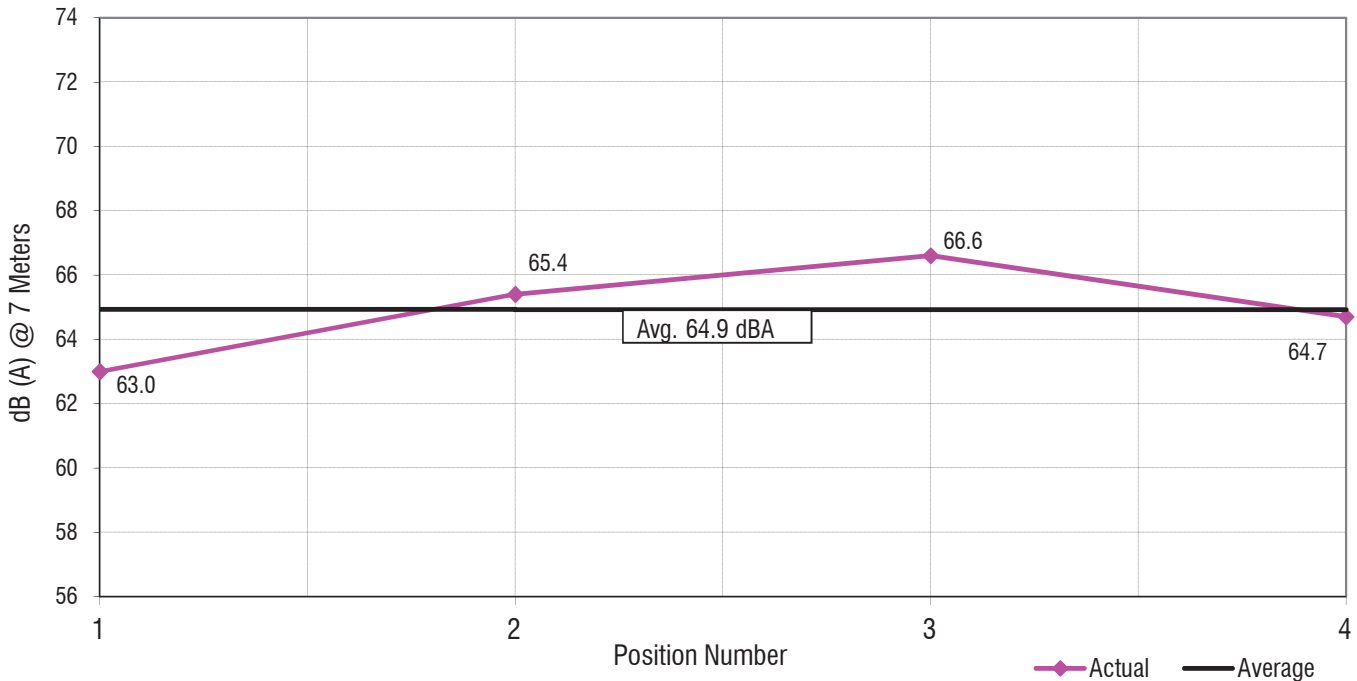

Notes:

1. All positions 23 ft (7M) from side faces of generator set.
2. Generator operating at full load.
3. Test conducted on a 100 foot diameter asphalt surface.
4. Non-enclosed sets do not include exhaust sound during testing.

EXHAUST EMISSIONS DATA

**STATEMENT OF EXHAUST EMISSIONS
2016 SPARK-IGNITED GENERATORS
INDUSTRIAL SERIES**

NON-SCAQMD												
Model	Engine	EPA Engine Family	Fuel	CATALYST Req'd	Comb Cat or Separate Cat	EPA Cert #	Grams/bhp-hr.			Rated RPM	BHP	Fuel Flow (lb/hr)
							THC	NOx	CO			
SG035	5.4	GGNXB05.42NN	NG	No	NR	GGNXB05.42NN-049	1.60	2.52	95.32	1800	82.10	36.91
SG035	5.4	GGNXB05.42NL	LPG	No	NR	GGNXB05.42NL-048	1.24	3.45	112.01	1800	82.30	34.60
SG050	5.4	GGNXB05.42NN	NG	No	NR	GGNXB05.42NN-049	1.60	2.52	95.32	1800	82.10	36.91
SG050	5.4	GGNXB05.42NL	LPG	No	NR	GGNXB05.42NL-048	1.24	3.45	112.01	1800	82.30	34.60
SG050	6.8	GGNXB06.82NL	LPG	No	NR	GGNXB06.82NL-010	1.86	2.67	172.30	1800	84.66	46.55

NR: Not Required

Refer to page 2 for definitions and advisory notes.

CALIFORNIA SCAQMD CERTIFIED												
Model	Engine	EPA Engine Family	Fuel	CATALYST Req'd	SCAQMD CEP #	EPA Cert #	Grams/bhp-hr.			Rated RPM	BHP	Fuel Flow (lb/hr)
							THC	NOx	CO			
SG035	5.4	GGNXB05.42L1	NG	Yes	530212	GGNXB05.42L1-017	0.38	0.22	0.64	1800	81.95	24.91
SG035	5.4	GGNXB05.42L2	LPG	Yes	530215	GGNXB05.42L2-018	0.04	0.10	0.70	1800	81.70	29.13
SG050	5.4	GGNXB05.42L1	NG	Yes	530212	GGNXB05.42L1-017	0.38	0.22	0.64	1800	81.95	24.91
SG050	5.4	GGNXB05.42L2	LPG	Yes	530215	GGNXB05.42L2-018	0.04	0.10	0.70	1800	81.70	29.13
SG050	6.8	GGNXB06.82L6	LPG	Yes	470347	GGNXB06.82L6-024	0.01	0.05	0.50	1800	85.92	34.14

Refer to page 2 for definitions and advisory notes.

18-1015-182 of 135

EXHAUST EMISSIONS DATA

STATEMENT OF EXHAUST EMISSIONS 2016 SPARK-IGNITED GENERATORS

2016 EPA SPARK-IGNITED EXHAUST EMISSIONS DATA

Effective since 2009, the EPA has implemented exhaust emissions regulations on stationary spark-ignited (gaseous) engine generators for emergency applications. All Generac spark-ignited gensets, including SG, MG, QTA and QT series gensets, that are built with engines manufactured in 2009 and later meet the requirements of 40CFR part 60 subpart JJJJ and are EPA certified. These generator sets are labeled as EPA Certified with decals affixed to the engines' valve covers.

The attached documents summarize the general information relevant to EPA certification on these generator sets. This information can be used for submittal data and for permitting purposes, if required. These documents include the following information:

EPA Engine Family

The EPA Engine Family is assigned by the Manufacturer under EPA guidelines for certification purposes and appears on the EPA certificate.

Catalyst Required

Indicates whether an exhaust catalyst and Air/Fuel Ratio control system are required on the generator set to meet EPA certification requirements. Generally, units rated 80kW and smaller do not require a catalyst to meet EPA certification requirements. Please note that some units that do not require a catalyst to meet EPA requirements do need a catalyst if the California SCAQMD option is selected. Please see "California SCAQMD" below for additional information on this option.

Combination Catalyst or Separate Catalyst

SG and MG series generator sets typically utilize a single combination catalyst/silencer as part of meeting EPA certification requirements. Many QT and QTA series generator sets use the same engines as SG and MG series units, but have different exhaust configurations that require the use of conventional silencers with additional separate catalysts installed.

EPA Certificate Number

Upon certification by the EPA, a Certificate Number is assigned by the EPA.

Emissions Actuals - Grams/bhp-hr

Actual exhaust emission data for Total Hydrocarbons (THC), Nitrogen Oxides (NOx) and Carbon Monoxide (CO) that were submitted to EPA and are official data of record for certification. This data can be used for permitting if necessary. Values are expressed in grams per brake horsepower-hour; to convert to grams/kW-hr, multiply by 1.341. Please see advisory notes below for further information.

California Units, SCAQMD CEP Number

A separate low-emissions option is available on many Generac gaseous-fueled generator sets to comply with the more stringent South Coast Air Quality Management District requirements that are recognized in certain areas in California. Gensets that include this option are also EPA Certified.

General Advisory Note to Dealers

The information provided here is proprietary to Generac and its' authorized dealers. This information may only be disseminated upon request, to regulatory governmental bodies for emissions permitting purposes or to specifying organizations as submittal data when expressly required by project specifications, and shall remain confidential and not open to public viewing. This information is not intended for compilation or sales purposes and may not be used as such, nor may it be reproduced without the expressed written permission of Generac Power Systems, Inc.

Advisory Notes on Emissions Actuals

- The stated values are actual exhaust emission test measurements obtained from units representative of the generator types and engines described.
- Values are official data of record as submitted to the EPA and SCAQMD for certification purposes. Testing was conducted in accordance with prevailing EPA protocols, which are typically accepted by SCAQMD and other regional authorities.
- No emission values provided are to be construed as guarantees of emissions levels for any given Generac generator unit.
- Generac Power Systems reserves the right to revise this information without prior notice.
- Consult state and local regulatory agencies for specific permitting requirements.
- The emissions performance data supplied by the equipment manufacturer is only one element required toward completion of the permitting and installation process. State and local regulations may vary on a case-by-case basis and must be consulted by the permit applicant/equipment owner prior to equipment purchase or installation. The data supplied herein by Generac Power Systems cannot be construed as a guarantee of installability of the generator set.
- The emission values provided are the result of multi-mode, weighted scale testing in accordance with EPA testing regulations, and may not be representative of any specific load point.
- The emission values provided are not to be construed as emission limits.



**UNITED STATES ENVIRONMENTAL PROTECTION AGENCY
2016 MODEL YEAR
CERTIFICATE OF CONFORMITY
WITH THE CLEAN AIR ACT**

**OFFICE OF TRANSPORTATION
AND AIR QUALITY
ANN ARBOR, MICHIGAN 48105**

Certificate Issued To: Generac Power Systems, Inc.
(U.S. Manufacturer or Importer)

Certificate Number: GGNXB05.42NL-048

Effective Date:
10/20/2015
Expiration Date:
12/31/2016

Byron J. Bunker, Division Director
Compliance Division

Issue Date:
10/20/2015
Revision Date:
N/A

Manufacturer: Generac Power Systems, Inc.
Engine Family: GGNXB05.42NL
Mobile/Stationary Certification Type: Stationary

Fuel: LPG/Propane

Emission Standards:

Part 90 Phase 1

CO (g/kW-hr) : 519

HC + NOx (g/kW-hr) : 13.4

Emergency Use Only : Y

Pursuant to Section 213 of the Clean Air Act (42 U.S.C. section 7547) and 40 CFR Part 60, 1065, 1068, and 60 (stationary only and combined stationary and mobile) and subject to the terms and conditions prescribed in those provisions, this certificate of conformity is hereby issued with respect to the test engines which have been found to conform to applicable requirements and which represent the following nonroad engines, by engine family, more fully described in the documentation required by 40 CFR Part 60 and produced in the stated model year.

This certificate of conformity covers only those new nonroad spark-ignition engines which conform in all material respects to the design specifications that applied to those engines described in the documentation required by 40 CFR Part 60 and which are produced during the model year stated on this certificate of the said manufacturer, as defined in 40 CFR Part 60. This certificate of conformity does not cover nonroad engines imported prior to the effective date of the certificate.

It is a term of this certificate that the manufacturer shall consent to all inspections described in 40 CFR 1068.20 and authorized in a warrant or court order. Failure to comply with the requirements of such a warrant or court order may lead to revocation or suspension of this certificate for reasons specified in 40 CFR Part 60. It is also a term of this certificate that this certificate may be revoked or suspended or rendered void *ab initio* for other reasons specified in 40 CFR Part 60.

This certificate does not cover large nonroad engines sold, offered for sale, or introduced, or delivered for introduction, into commerce in the U.S. prior to the effective date of the certificate.



5/23/2017

NCIC File No.: ELD-17-37

Jared Kearsley
Epic Wireless Group
8700 Auburn Folsom Road, Suite 400
Granite Bay, CA 95746

Records Search Results for
AT&T/Epic Wireless/El Dorado County Resource Record Search Request – APN: 105-110-81

Jared Kearsley:

Per your request received by our office on 5/5/2017, a complete records search was conducted by searching California Historic Resources Information System (CHRIS) maps for cultural resource site records and survey reports in El Dorado County within a 1/4-mile radius of the proposed project area.

Review of this information indicates that the proposed project area contains zero (0) prehistoric-period resource(s) and zero (0) historic-period cultural resource(s). Additionally, zero (0) cultural resources study reports on file at this office cover a portion of the proposed project area.

Outside the proposed project area, but within the 1/4-mile radius, the broader search area contains zero (0) prehistoric-period resource(s) and zero (0) historic-period cultural resource(s). Additionally, one (1) cultural resources study reports on file at this office cover a portion of the broader search area.

In this part of El Dorado County, archaeologists locate prehistoric-period habitation sites “along streams or on ridges or knolls, especially those with southern exposure.” (Moratto 1984:290) This region is known as the ethnographic-period territory of the Nisenan, also called the Southern Maidu. The Nisenan maintained permanent settlements along major rivers in the Sacramento Valley and foothills; they also periodically traveled to higher elevations (Wilson and Towne 1978:387-389). The proposed project search area is situated in the Sierra Nevada about one eighth of a mile east of drainage to Jacobs Creek. Given the extent of known cultural resources and the environmental setting, there is low potential for locating prehistoric-period cultural resources in the immediate vicinity of the proposed project area.

Within the search area, the 1866 GLO plat of T11N, R9E shows no evidence of nineteenth-century historical activity. The 1950 Coloma 7.5' USGS topographical map shows evidence of a twentieth-century unpaved road. Given the extent of known cultural resources and patterns of local history, there is low potential for locating historic-period cultural resources in the immediate vicinity of the proposed project area.

SENSITIVITY STATEMENT:

- 1) With respect to cultural resources, it appears that the proposed project area **is not sensitive**.
- 2) Should the lead agency/authority require a cultural resources survey, a list of qualified local consultants can be found at <http://chrisinfo.org>.
- 3) If cultural resources are encountered during the project, avoid altering the materials and their context until a qualified cultural resources professional has evaluated the project area. **Project personnel should not collect cultural resources**. Prehistoric-period resources include: chert or obsidian flakes, projectile points, and other flaked-stone artifacts; mortars, grinding slicks, pestles, and other groundstone tools; and dark friable soil containing shell and bone dietary debris, heat-affected rock, or human burials. Historic-period resources include: stone or adobe foundations or walls; structures and remains with square nails; mine shafts, tailings, or ditches/flumes; and refuse deposits or bottle dumps, often located in old wells or privies.
- 4) Identified cultural resources should be recorded on DPR 523 (A-J) historic resource recordation forms, available at http://ohp.parks.ca.gov/?page_id=1069.
- 5) Review for possible historic-period cultural resources has included only those sources listed in the referenced literature and should not be considered comprehensive. The Office of Historic Preservation has determined that buildings, structures, and objects 45 years or older may be of historical value. If the area of potential effect contains such properties not noted in our research, they should be assessed by an architectural historian before commencement of project activities.

Due to processing delays and other factors, not all of the historical resource reports and resource records that have been submitted to the Office of Historic Preservation are available via this records search. Additional information may be available through the federal, state, and local agencies that produced or paid for historical resource management work in the search area. Additionally, Native American tribes have historical resource information not in the California Historical Resources Information System (CHRIS) Inventory, and you should contact the California Native American Heritage Commission for information on local/regional tribal contacts.

The California Office of Historic Preservation (OHP) contracts with the California Historical Resources Information System's (CHRIS) regional Information Centers (ICs) to maintain information in the CHRIS inventory and make it available to local, state, and federal agencies, cultural resource professionals, Native American tribes, researchers, and the public. Recommendations made by IC coordinators or their staff regarding the interpretation and application of this information are advisory only. Such recommendations do not necessarily represent the evaluation or opinion of the State Historic Preservation Officer in carrying out the OHP's regulatory authority under federal and state law.

Thank you for using our services. Please contact North Central Information Center at (916) 278-6217 if you have any questions about this record search. An invoice is enclosed.

Sincerely,

Dr. Nathan Hallam, Coordinator
North Central Information Center



SYCAMORE ENVIRONMENTAL CONSULTANTS, INC.

6355 Riverside Blvd., Suite C, Sacramento, CA 95831
916/ 427-0703 Fax 916/ 427-2175
www.sycamoreenv.com

14 July 2017

Mr. Jared Kearsley
Leasing / Zoning Manager
Epic Wireless Group
8700 Auburn Folsom Road, Suite 400
Granite Bay, CA 95746
Phone: 916-755-1326

Subject: *AT&T Gold Hill Site CVL03054 Project in El Dorado County, CA*

Dear Mr. Kearsley:

Sycamore Environmental prepared a Biological Resources Evaluation (BRE) for the AT&T Gold Hill Site CVL03054 Project in El Dorado County, CA. The BRE is a baseline document. This letter identifies potential biological resource issues and recommended avoidance and minimization measures.

Trees

The 2004 El Dorado County General Plan Policy 7.4.4.4 requires all new development projects adhere to tree canopy retention and replacement standards. For parcels greater than one acre in size with 1 percent oak tree canopy cover or greater, 90 percent of the canopy must be retained.

Recommendation:

- The limits of construction will be fenced by the Contractor to minimize impacts on trees. Trucks and other vehicles will not be allowed to park beyond, nor shall equipment be stored beyond, the fencing. No vegetation removal or ground disturbing activities will be permitted beyond the fencing. Incorporation of this measure will help ensure that trees are not impacted beyond what is permitted by construction entitlements.

Migratory Birds and Birds of Prey

Under the MBTA, nests that contain eggs or unfledged young are not to be disturbed during the breeding season. Nesting or attempted nesting by migratory birds and birds-of-prey is anticipated from 15 January through 31 August.

Recommendation:

- Tree and vegetation removal shall occur outside of the nesting season (15 January through 31 August annually). All tree removal shall occur between 1 September and 14 January, which is outside of nesting season for MBTA and Fish and Game Code protected birds. If work occurs outside the nesting season, there will be no need to conduct a preconstruction survey for active nests.
- If project work occurs during the nesting season, a qualified biologist shall conduct a pre-construction survey for nesting birds of prey and other birds protected by the MBTA and Fish and Game Code within 15 days prior to the start of construction. The survey area shall cover the Project, a 500 ft radius for nesting birds of prey, and a 100 ft radius for all other MBTA and Fish and Game Code protected birds. If no active nest of a bird of prey, MBTA bird, or other Fish and Game Code-protected bird is found, then no further mitigation measures are necessary.

- Should an active nest of a protected bird be identified, an exclusion zone of 500 feet shall be established around the nest if it is a bird of prey, and 100 feet if it is a protected bird other than a bird of prey. Buffer sizes may be adjusted at the discretion of the biologist depending on the species of bird, the location of the nest relative to the project, the existing level of disturbance, and other site-specific conditions. No work will be allowed in the exclusion zone until the biologist determines that the nest is no longer active, or monitoring determines that a smaller ESA will protect the active nest.
- From 15 January through 31 August, if additional trees or shrubs need to be trimmed and/or removed after construction has started, a survey will be conducted for active nests in the area to be affected. If an active nest is found, the above measures will be implemented.
- If an active nest is identified in or adjacent to the construction zone after construction has started, the above measures will be implemented to ensure construction is not causing disturbance to the nest.

Please contact me with any questions.

Sincerely,



Jessie Quinn, Ph.D.
Ecologist

Enclosure: Biological Resources Evaluation

Biological Resources Evaluation
for the
AT&T Gold Hill Site CVL03054 Project
El Dorado County, CA

Prepared by:

Sycamore Environmental Consultants, Inc.

6355 Riverside Blvd., Suite C

Sacramento, CA 95831

Phone: 916/ 427-0703

Contact: Jessie Quinn

Prepared for:

Epic Wireless Group, LLC

8700 Auburn Folsom Road, Suite 400

Granite Bay, CA 95746

Phone: 916/ 755-1326

Contact: Jared Kearsley

July 2017

[This page intentionally left blank]

Biological Resources Evaluation
for the
AT&T Gold Hill Site CVL03054
El Dorado County, CA

TABLE OF CONTENTS

I. SUMMARY OF FINDINGS AND CONCLUSIONS 1

II. INTRODUCTION..... 1

A. Purpose of Report 1

B. Project Location 1

C. Project Applicant 1

D. Project Description..... 1

III. STUDY METHODS..... 7

A. Studies Conducted 7

B. Survey Dates, Personnel, and Coverage 7

C. Problems Encountered and Limitations That May Influence Results 7

D. Literature Search 7

E. Field Survey Methods 8

F. Mapping 8

IV. ENVIRONMENTAL SETTING 9

A. Soils 9

B. Weather and Climate Conditions 9

C. Biological Communities 13

 1. Structures/landscaping/gravel roads 17

 2. Ruderal 17

D. The Existing Level of Disturbance 17

V. BIOLOGICAL RESOURCES IN THE BIOLOGICAL STUDY AREA 18

A. Determination of Special-Status Species and Communities in the Biological Study Area 18

B. Evaluation of Special-Status Natural Communities..... 18

C. Evaluation of Special-Status Fish and Wildlife Species 18

 1. Birds 18

D. Evaluation of Special-Status Plant Species..... 19

E. Potentially Jurisdictional Waters 19

VI. LITERATURE CITED & PERSONAL COMMUNICATIONS 20

A. Literature Cited 20

VII. PREPARERS..... 21

FIGURES

Figure 1. Project Location.....	3
Figure 2. Aerial Photograph.....	5
Figure 3. Soils Map.....	11
Figure 4. Biological Resources Map.....	15

TABLES

Table 1. USGS Quads Evaluated for the AT&T Gold Hill Site Plan Project.....	8
Table 2. Biological Communities and Other Features in the BSA	13

APPENDICES

Appendix A. Plant and Wildlife Species Observed	
Appendix B. USFWS Species List	
Appendix C. CNDDDB Summary Report and CNPS Inventory Query	
Appendix D. Photographs	

I. SUMMARY OF FINDINGS AND CONCLUSIONS

This Biological Resources Evaluation report was prepared for the AT&T Gold Hill Site CVL03054 Project (Project) to document baseline biological conditions observed in 2017. The approximately 0.39-acre (ac) Biological Study Area (BSA) is located south of Highway 49 in the community of Lotus, in unincorporated El Dorado County, CA.

Trees and vegetation in and adjacent to the BSA provide habitat for nesting birds protected by the Migratory Bird Treaty Act (MBTA) and Fish and Game Code. The nesting bird season is generally defined as 15 February through 31 August, though some species of birds may begin nesting as early as 15 January.

No special-status wildlife or plant species have the potential to occur in the BSA. The BSA is in a previously disturbed area within an Important Biological Corridor. The BSA is not in a Rare Plant Mitigation Area or within Important Habitat for Migratory Deer Herds. Based on aerial images in Google Earth from October 2016, the 10.065-acre parcel on which the BSA is located contains more than 1 percent canopy cover of oak woodlands. There are no wetlands or waters in the BSA.

II. INTRODUCTION

A. Purpose of Report

The purpose of this Biological Resources Evaluation (BRE) report is to document baseline biological resources in the AT&T Gold Hill Site CVL03054 Project (Project) Biological Study Area (BSA).

B. Project Location

The approximately 0.39-ac BSA is located in the western foothills of the Sierra Nevada Mountains in unincorporated El Dorado County, California. The BSA is located in a rural residential area, and is bound by large lot residences to the north and undeveloped mixed oak woodland to the south. The BSA is on the Coloma USGS topographic quad (T11N R9E, Section 14, Mt. Diablo Base & Meridian; Figure 1), and is in the South Fork American Hydrologic Unit (Hydrologic Unit Code 18020129). The geographic coordinates of the BSA are 38.802850° north, 122.648761° east (WGS84), and the UTM coordinates (Zone 10N) are 679,067 meters east, 4,296,912 meters north. Elevation in the BSA ranges from approximately 1,110 to 1,050 ft above sea level. The BSA is located on the top of a hill. Figure 2 is an 11 July 2016 aerial photo of the BSA and surrounding area.

C. Project Applicant

Applicant:
AT&T Mobility
2600 Camino Ramon
San Ramon, CA 94583

Consulting Planner
Epic Wireless Group, LLC
8700 Auburn Folsom Road, Suite 400
Granite Bay, CA 95746
Phone: 916/ 755-1326
Contact: Mr. Jared Kearsley

D. Project Description

AT&T intends to construct a wireless telecommunications facility at 6812 Gods Way, Lotus, in northeastern El Dorado County. The proposed AT&T Gold Hill Site CVL03054 Project (Project) facility

tower will be a new 110-ft monopine tower with a new GPS antenna; six wireless antennas and nine remote radio units (RRUs) mounted at 108 ft; six wireless antennas, one surge protector, and nine RRUs mounted at 100 ft; and six RRUs and three surge protectors on a collar mount directly below the sectors. In the future, the tower can also accommodate three additional RRUs and two 4-ft diameter microwave dishes mounted at 89.5 ft. Future antennas can be mounted by other carriers at approximately 82 and 67 ft. The tower has been designed with pine foliage to match the existing surrounding trees. The foliage would extend horizontally approximately seven ft above the top of the structure to an overall structure height of approximately 117 ft. Antennas will be concealed with socks. The monopine “trunk” and RRUs will be painted brown.

The Project will extend an existing 12-ft wide gravel driveway on the property by roughly 100 ft to provide access to the proposed facility. The new access road will remain within the proposed 15-ft wide lessee access utility easement. The facility will include a pre-fabricated equipment shelter and a new 15-Kw propane generator and a 500-gallon propane tank, each located on new 50-ft² concrete pads. The facility will be located on a 35-ft by 40-ft lease area and enclosed with a new 6-ft chain link fence and 12-ft wide double access gate. Connecting the facility with existing power and fiber lines will require excavation of an approximately 155-ft long linear utility trench along the proposed access road, through which to run cables. At the point of connection, a 6-ft wide and 10.5-ft long utility easement is proposed, which will allow the Project to join the new cables to the existing joint utility pole with a transformer. Two new underground power and telecommunication conduits will be installed less than 5 ft northeast of the double gate of the lease area.

The Project does not include removal or pruning of oak trees.

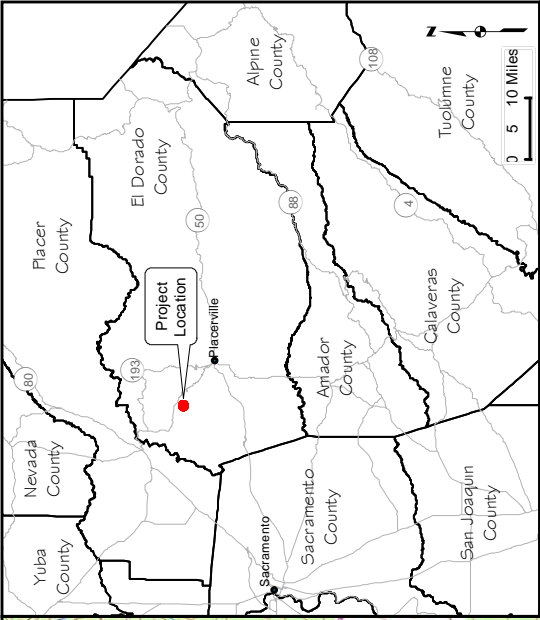

AT&T Gold Hill Site
 CVL03054 Project
 El Dorado County, CA
 6 July 2017

Figure 1. Project Location Map

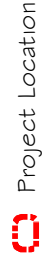

Project Location

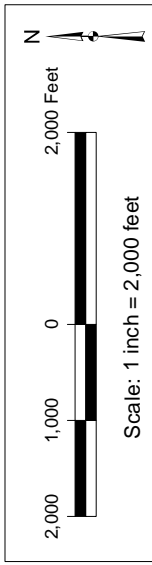

SYCAMORE
 Environmental
 Consultants, Inc.

Coloma, CA (Revised 1973)
 CASIL California USGS Digital Raster Graphics (DRG),
 7.5 Minute (C) Series, Albers NAD83 Mosaics (MrSID)
 o_nw0202.sd

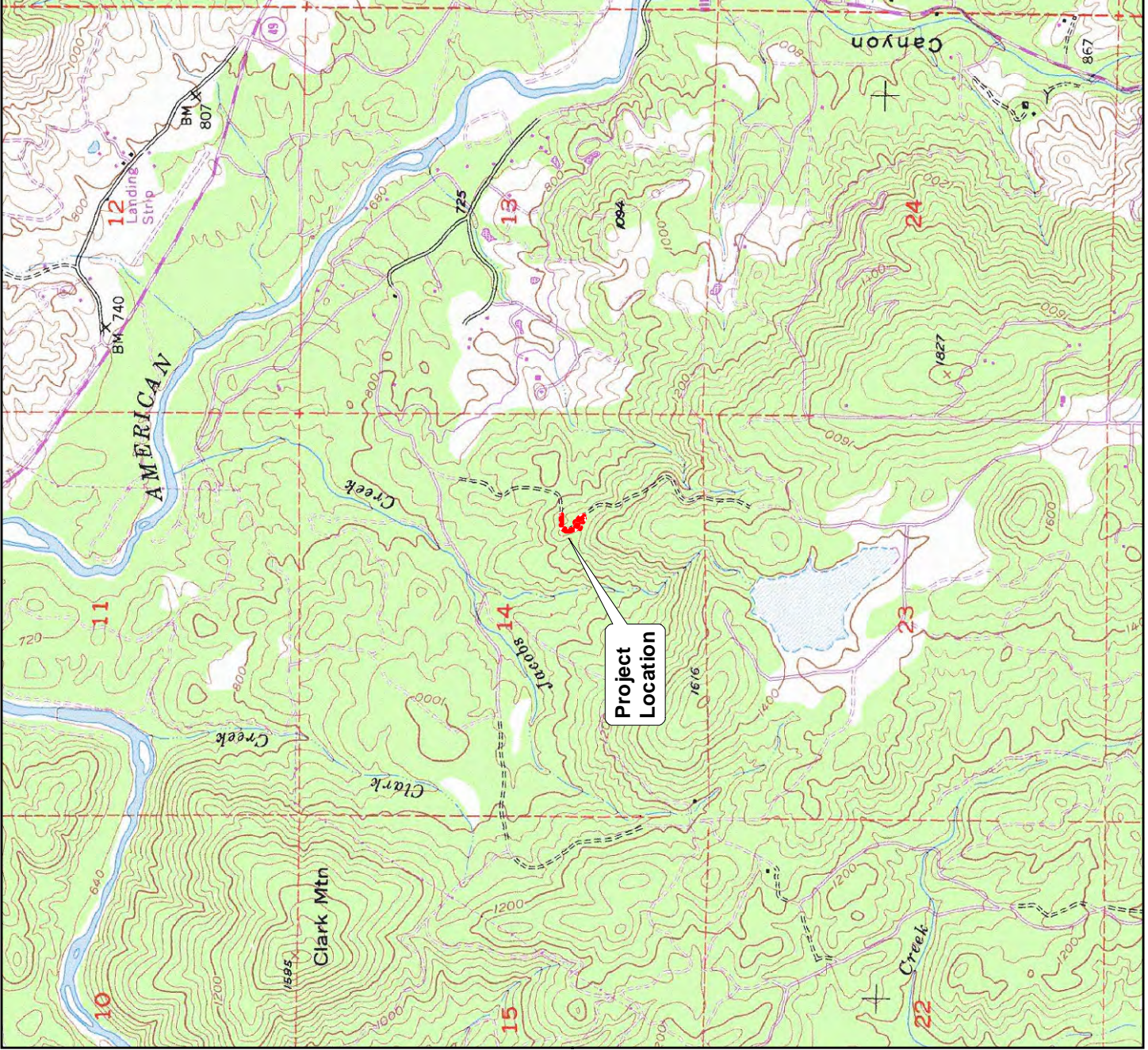

[This page intentionally left blank]

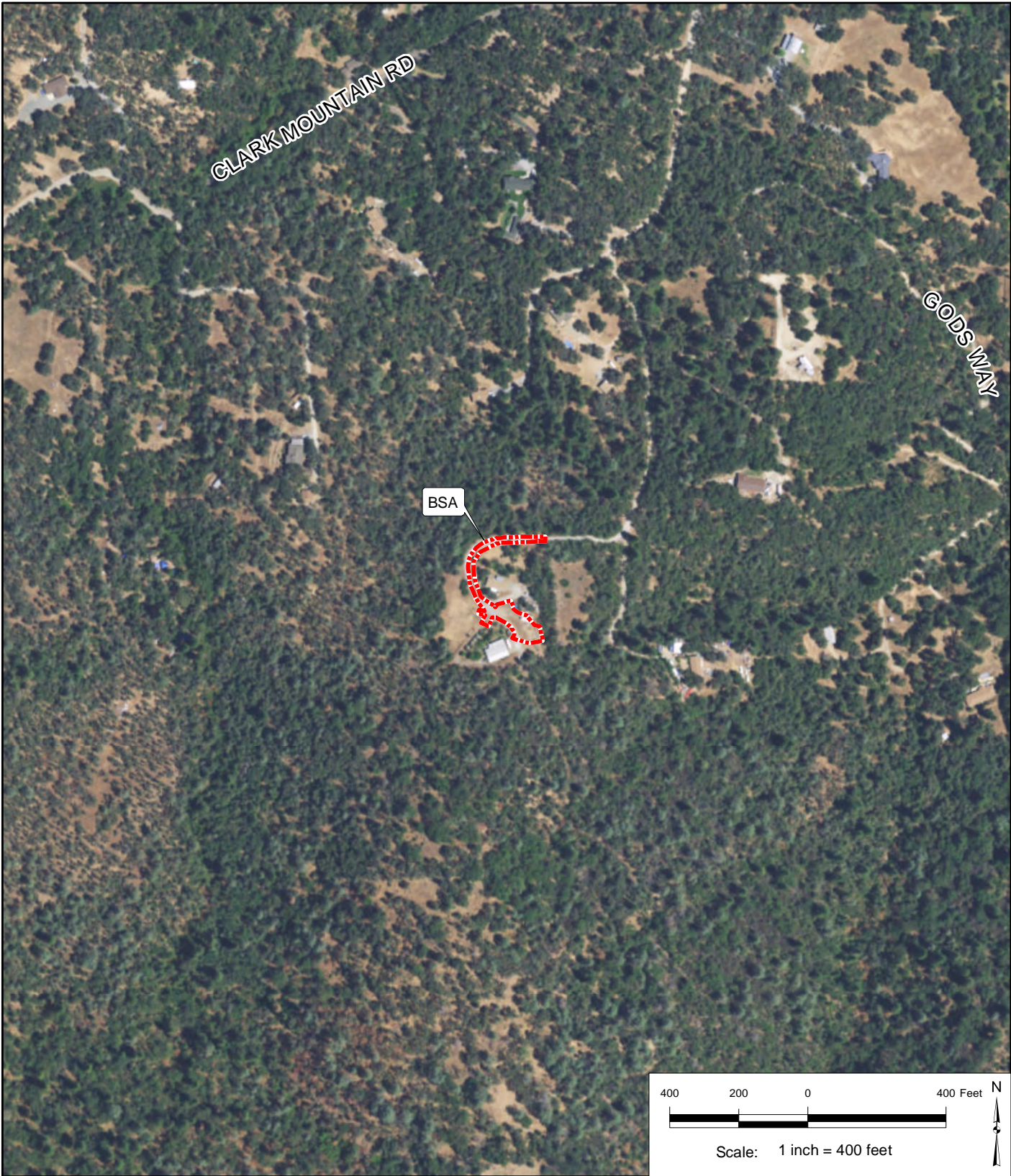

AT&T Gold Hill Site
 CVL03054 Project
 El Dorado County, CA
 6 July 2017

 Biological Study Area (BSA)



Aerial Photograph: 11 July 2016
 NAIP2016 USDA FSA Imagery
 ESRI ArcGIS Basemap Layer

Figure 2. Aerial Photograph

[This page intentionally left blank]

III. STUDY METHODS

A. Studies Conducted

An evaluation of biological resources was conducted to determine whether any special-status plant or wildlife species, their habitat, or sensitive habitats occur in the BSA. Data on known special-status species and habitats in the area was obtained from state and federal agencies. Maps and aerial photographs of the BSA and surrounding area were reviewed. The field survey, map review, and a review of the biology of evaluated species and habitats were used to determine the special-status species and sensitive habitats that could occur in the BSA.

Special-status species in this report are those listed under the federal or state endangered species acts, under the California Native Plant Protection Act, as a California species of special concern or fully protected by the California Department of Fish and Wildlife (CDFW), or that are California Rare Plant Rank 1 or 2 (CNPS 2017). This is consistent with special-status species definitions in the El Dorado County General Plan EIR (2004). Special-status natural communities are waters, wetlands, riparian communities, and any natural community ranked S1, S2, or S3 by CDFW (2010). Special-status species and communities may also include those considered locally important or sensitive. El Dorado County identifies Important Biological Corridors and Important Habitat for Migratory Deer Herds in its General Plan (2016), and Rare Plan Mitigation areas per the Board of Supervisors Resolution No. 205-98. General Plan Policy 7.4.4.4 requires all new development projects adhere to tree canopy retention and replacement standards.

Data received from USFWS, CNDDDB, and CNPS records (Appendices B and C) were used to evaluate species and habitats of concern with potential to occur within the BSA. The CNDDDB tracks other species that have not been designated by CDFW as a California species of special concern; these species were not evaluated as special-status species in this BRE.

B. Survey Dates, Personnel, and Coverage

Fieldwork for this BRE, covering the 0.39-ac BSA, was conducted by Jessica Orsolini, Senior Wildlife Biologist, and Juan Mejia, Biologist, on 28 June 2017.

C. Problems Encountered and Limitations That May Influence Results

No problems or limitations were encountered.

D. Literature Search

An IPaC Trust Resource Report was obtained from the U.S. Fish and Wildlife Service (USFWS), Sacramento Field Office on 26 June 2017 (Appendix B). The list identifies federal-listed, candidate, and proposed species that potentially occur in, or could be affected by, the Project.

The California Natural Diversity Database (CNDDDB) was queried prior to field surveys for known occurrences of special-status species in or near the BSA (Coloma Quad and the eight surrounding quads). The list was updated most recently on 26 June 2017 (CDFW 2017, Appendix C). The California Native Plant Society (CNPS) inventory of rare and endangered plants was queried prior to field surveys for known occurrences of special-status plants in or near the BSA (Coloma Quad and the eight surrounding

quads). The list was updated most recently on 26 June 2017 (Appendix C). Table 1 lists the USGS quads evaluated.

Table 1. USGS Quads Evaluated for the AT&T Gold Hill Site CVL03054 Plan Project

Auburn	Greenwood	Georgetown
Pilot Hill	Coloma	Garden Valley
Clarksville	Shingle Springs	Placerville

E. Field Survey Methods

Biological surveys conducted for this report consisted of biologists walking through the BSA while looking for special-status wildlife species, their sign, and their habitat. Areas adjacent to the BSA were also inspected for important habitat features such as elderberry shrubs, vernal pools, burrows, and other wetlands/waters. Biological community boundaries were recorded with a sub-meter accurate GPS. All wildlife species observed in or near the BSA were recorded (Appendix A).

F. Mapping

Biological communities observed by Sycamore Environmental were mapped using a Trimble GeoXT sub-meter accurate GPS. The 6 July aerial photo in Figures 2 and 4 was downloaded from ESRI World Imagery. Biological communities were mapped based on GPS data, field observations, and interpretation of the aerial photographs available on Google Earth. No additional sensitive biological resources were observed.

IV. ENVIRONMENTAL SETTING

The BSA is located in an undeveloped area south of highway 49 in Coloma, CA. Land use adjacent to the BSA consists of undeveloped forest and dispersed residences. The South Fork American River is to the north and Arrowbee Lake is located to the south. The parcel on which the BSA is located is approximately 10.065 acres in size.

A. Soils

Mapped soil units in the BSA were determined using the Soil Survey of El Dorado Area (NRCS 1974). Mapped soil units in the BSA is Boomer very rocky loam, 30-50% slopes (Figure 3; NRCS 2016). Figure 3 is a soils map.

Boomer very rocky loam, 30-50% Percent Slopes:

These soils occur on uplands with black oak, ponderosa pine and manzanita. A typical profile of Boomer loam is dark brown (7.5YR 5/4) loam from 0 to 3 inches; dark brown (7.5YR 3/4) gravelly sandy clay loam from 3 to 11 inches; yellowish red (5YR 4/6) gravelly clay loam from 11 to 23 inches; yellowish red (5YR 4/6) gravelly clay loam from 11 to 23 inches; yellowish red (5YR 4/6) clay loam from 23 to 33 inches; strong brown (7.5 YR 5/8) silty clay loam from 33 to 45 inches; and strongly weathered greenstone below 45 inches. This soil is neutral to medium acidic. Boomer series are fine-loamy, mixed, superactive mesic Ultic Haploxeralfs. These soils formed in material weathered from metavolcanic rock. Permeability is moderately slow. Surface runoff is slow to very rapid and erosion hazard is moderate.



B. Weather and Climate Conditions

Fieldwork was conducted on 28 June 2017. Precipitation in California is typically reported for the period from 1 July through 30 June of the next calendar year. The historic average precipitation from 1 July through 25 April for the National Weather Service Sacramento Executive Airport gauge is 18.18 inches. From 1 July 2016 through 25 April 2017, the Sacramento Executive Airport Gauge received 33.08 inches of rain (NWSFO 2017), or 182% of the average precipitation. The BSA had wetter than average hydrologic conditions during the 28 June fieldwork. Weather during the survey was sunny, calm, and dry.

[This page intentionally left blank]

AT&T Gold Hill Site
 CVL03054 Project
 El Dorado County, CA
 6 July 2017

Figure 3. Soils Map

-  Biological Study Area (BSA)
-  Soil Boundary

Soil Mapping Unit	Symbol Name
AwD Auburn silt loam, 2 to 30 percent slopes	
BkE Boomer very rocky loam, 30 to 50 percent slopes	

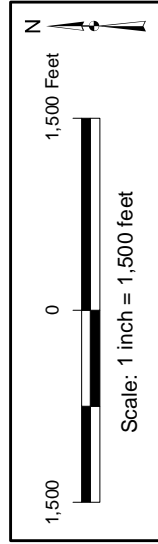

SYCAMORE
 Environmental
 Consultants, Inc.

Soil Survey Geographic (SSURGO) database for
 El Dorado Area, California, USDA, NRCS
 URL: <http://SoilDataMart.nrcs.usda.gov/>

Aerial Photograph: 11 July 2016
 NAIP2016_USDA FSA Imagery
 ESRI ArcGIS Basemap Layer

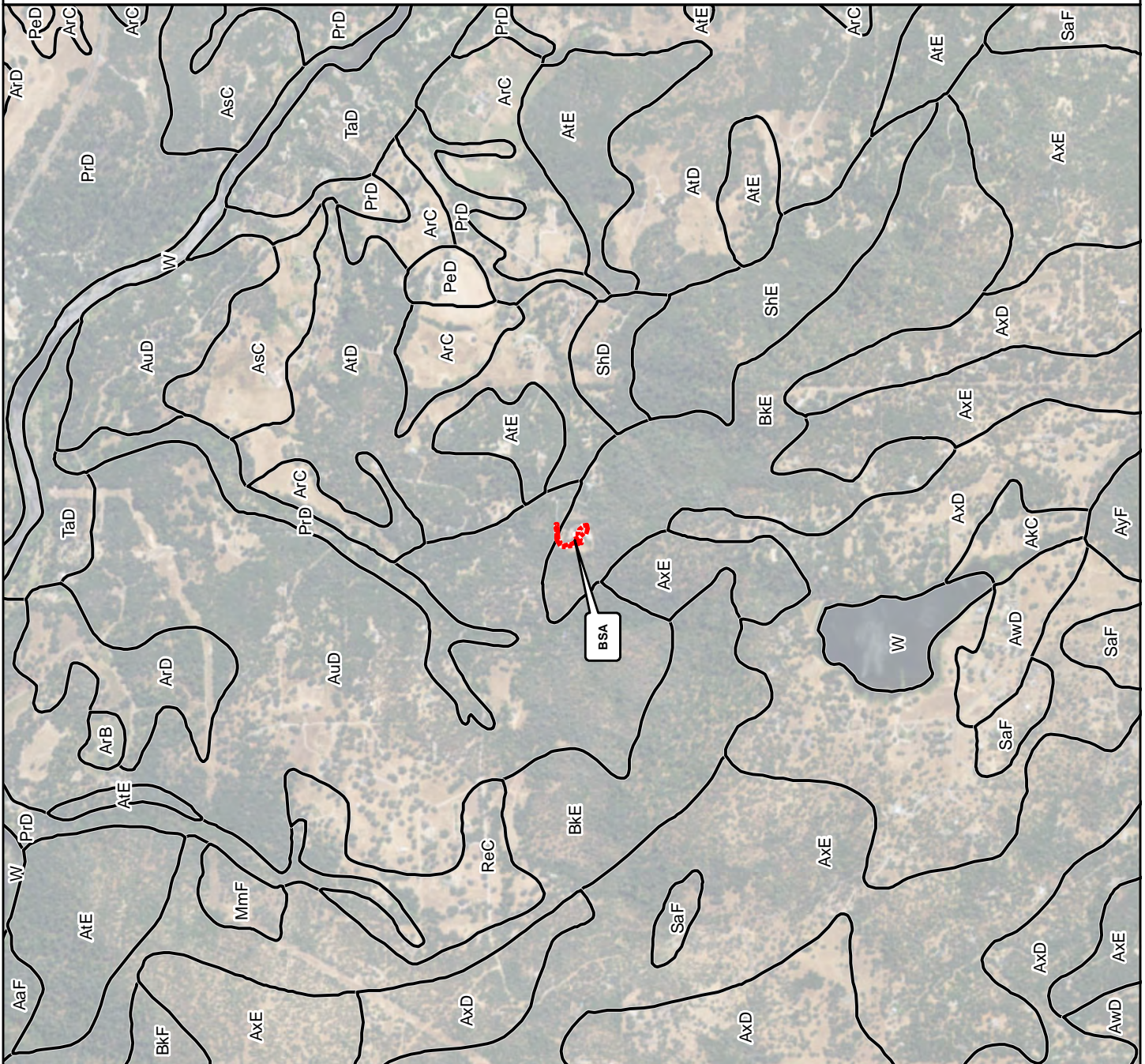

[This page intentionally left blank]

C. Biological Communities

Biological communities are defined by species composition and relative abundance. Biological communities correlate where applicable with the list of California terrestrial natural communities recognized by CDFW (2010). Descriptions of biological communities present in the BSA are included below. Biological community descriptions include plant species identified during the field surveys. Biological communities are mapped in Figure 4 and their acreages are in Table 2. Photographs of the BSA are in Appendix D.

Table 2. Biological Communities in the BSA

Biological Community	Vegetation Alliances and CDFW Alliance Codes ¹	Rarity Rank ²	Acreage ³
Structures/Landscaping/Gravel roads	--	--	0.26
Ruderal	--	--	0.13
Total:			0.39

¹ Vegetation alliances based on descriptions and classification methods in Sawyer et al. (2009). Alliance codes from CDFW (2010). Some communities may lack recognized vegetation alliances or contain multiple alliances.



² Rarity ranking follows NatureServe's Heritage Methodology and is based on degree of imperilment as measured by rarity, trends, and threats. State (S) ranks of 1-3 are considered highly imperiled by CDFW (2010). Nonnative vegetation has no rarity rank.

³ Acreages were calculated using ArcMap functions.

[This page intentionally left blank]



AT&T Gold Hill Site
 CVL03054 Project
 El Dorado County, CA
 6 July 2017

-  Biological Study Area (BSA)
-  Structures/Landscaping/Gravel roads
-  Ruderal (RUD)



Aerial Photograph:
 25 October 2016
 Google Earth Imagery

Figure 4.
 Biological Resources Map

[This page intentionally left blank]

1. Structures/landscaping/gravel roads

A total of 0.26 acre of developed land use occurs in the BSA, including a gravel road, structures, and associated landscaping.

2. Ruderal

A total of 0.13 ac of ruderal land occurs in the south end of the BSA on either side of the gravel road. This non-native grassland community is dominated by American bird's foot trefoil (*Acmispon americanus*) lesser hawkbit (*Leontodon saxatilis*), yellow starthistle (*Centaurea solstitialis*), harvest brodiaea (*Brodiaea elegans*), Monterey centaury (*Zeltnera muehlbergii*), prickly lettuce (*Lactuca seriola*), and clustered clover (*Trifolium glomeratum*). Ruderal land has no special status.

D. The Existing Level of Disturbance

The vast majority of the BSA has a high level of existing disturbance from the gravel roads, mowing of the grass, and human access.

V. **BIOLOGICAL RESOURCES IN THE BIOLOGICAL STUDY AREA**

A. **Determination of Special-Status Species and Communities in the Biological Study Area**

Field surveys were conducted by Sycamore Environmental biologists to determine if individuals or habitat for special-status species identified in the file data were present in the BSA. Special-status species for which suitable habitat is present are discussed below.

Special-status wildlife species, plant species, and communities for which suitable habitat is not present, or whose distributional limits preclude the possibility of their occurrence in the BSA, are not discussed in Section V of this report.

B. **Evaluation of Special-Status Natural Communities**

The BSA is located within an Important Biological Corridor (IBC), in a previously disturbed and developed area. There are no special-status natural communities within the BSA.

The project is not located within Important Migratory Deer Habitat.

Based on aerial images in Google Earth from October 2016, the 10.065-acre parcel on which the BSA is located contains more than 1 percent canopy cover of oak woodlands.

C. **Evaluation of Special-Status Fish and Wildlife Species**

1. **Birds**

Migratory Birds and Birds of Prey

STATUS: Fish and Game Code 3503.5 protects all birds in the orders Falconiformes and Strigiformes (collectively known as birds of prey). Birds of prey include raptors, falcons, and owls. Migratory birds are protected under the federal Migratory Bird Treaty Act (MBTA) of 1918 (16 U.S.C. 703-711). The MBTA makes it unlawful to take, possess, buy, sell, purchase, or barter any migratory bird listed in 50 CFR Part 10 including feathers or other parts, nests, eggs, or products, except as allowed by implementing regulations (50 CFR 21). All migratory bird species are protected by the MBTA. Any disturbance that causes direct injury, death, nest abandonment, or forced fledging of migratory birds, is restricted under the MBTA. Any removal of active nests during the breeding season or any disturbance that results in the abandonment of nestlings is considered a ‘take’ of the species under federal law.

HABITAT PRESENT IN THE BSA: No bird of prey nests or nests of other birds protected by the MBTA or Fish and Game Code were observed in the BSA during biological surveys. Bird species observed are listed in Appendix A. Trees and vegetation in the BSA provide nesting habitat for birds of prey and other birds protected by the MBTA and Fish and Game Code.

DISCUSSION: The nesting bird season is generally defined as February 15th through August 31st, though some species can begin nesting as nearly as January 15th.

D. Evaluation of Special-Status Plant Species

The project is not located in a Rare Plant Mitigation Area. There are no special status plant species with potential to occur in the BSA.

E. Potentially Jurisdictional Waters

Field surveys conducted by Sycamore Environmental biologists included evaluation of potential wetlands or waters within the BSA.

There are no potentially jurisdictional waters in the BSA.

VI. LITERATURE CITED & PERSONAL COMMUNICATIONS

A. Literature Cited

- Baldwin, B. et al. (ed.). 2012. *The Jepson Manual, Vascular Plants of California*, 2nd ed. University of California Press, Berkeley, CA.
- California Department of Fish and Wildlife (CDFW). 10 September 2010. List of California Vegetation Alliances. Biogeographic Data Branch, CNDDDB, Sacramento, CA.
- California Department of Fish and Wildlife (CDFW). April 2017 (2017a). Special Plant and Animal Lists, including the following: Special Vascular Plants, Bryophytes, and Lichens List, Endangered, Threatened and Rare Plants List, Special Animals List and Endangered and Threatened Animals List. Nongame Wildlife, Sacramento, CA. <http://www.dfg.ca.gov/wildlife/nongame/list.html>
- California Native Plant Society (CNPS). Accessed May and June 2017. Inventory of rare and endangered plants (online edition, v8-01a). California Native Plant Society, Sacramento, CA. <http://www.rareplants.cnps.org/>
- El Dorado County. January 2004, Certified 19 July 2004 (2004). El Dorado County general plan, final environmental impact report (EIR). Resolution No. 234-2004, State Clearinghouse No. 2001082030. Prepared by EDAW.
- El Dorado County. Adopted 19 July 2004, last amended 6 December 2016 (2016). 2004 El Dorado County General Plan A Plan for Managed Growth and Open Roads; A Plan for Quality Neighborhoods and Traffic Relief. Resolution No. 235-2004, State Clearinghouse No. 2001082030. Prepared by El Dorado County Planning Department, Placerville, CA.
- National Resources Conservation Service (NRCS). 16 September 2016. Soil Survey Geographic (SSURGO) database for El Dorado County, CA. USDA, NRCS. <http://SoilDataMart.nrcs.usda.gov>
- Natural Resources Conservation Service (NRCS). Accessed May 2017. Official soil series descriptions (OSD). Soil Survey Staff, United States Department of Agriculture. <https://soilseries.sc.egov.usda.gov/>
- National Weather Service Forecast Office (NWSFO), Sacramento, CA. Accessed July 2017. Observed Weather. <http://www.nws.noaa.gov/climate/index.php?wfo=sto>
- Sawyer, J. O., T. Keeler-Wolf, and J. M. Evens. 2009. *A manual of California vegetation*, 2nd ed. California Native Plant Society, Sacramento, CA.

VII. PREPARERS

Adrienne Levoy, B.S., Conservation and Resource Studies, University of California, Berkeley, CA. Over 9 years experience as a professional biologist. Conducts wildlife surveys, yellow-billed cuckoo, burrowing owl, and Swainson's hawk protocol surveys, biological resource evaluations, worker awareness training, and construction monitoring; prepares impact/mitigation analyses, and assists with permit application preparation. She prepares reports used in the CEQA/NEPA process that document resources, identify impacts, recommends mitigation measures, and assists with permit application preparation. She holds a USFWS recovery permit for listed yellow-billed cuckoo (TE-78073B-0) and a CDFW Scientific Collecting Permit (SC-13362).

Responsibilities: Report preparation.

Jessica Quinn, Ph.D., Ecology, University of California, Davis, CA. Over 8 years of experience as a professional ecologist. Conducts special-status plant and wildlife surveys; provides technical support for wetland delineations; and coordinates and prepares PES submissions. Project management, prepares CEQA documents and reports used in the CEQA/NEPA process that document resources, identify impacts, and recommend mitigation measures. She has managed and conducted wetland functional analyses, environmental risk assessments, environmental screening evaluations, and restoration design evaluations, and has received training in biology and survey techniques for CA red-legged frog, NEPA and Habitat Conservation Planning. Her background includes 13 additional years of experience managing and conducting ecological research on mammals, birds, and grassland ecology. Dr. Quinn holds a CDFW Rare, Threatened and Endangered Plant Voucher Collecting Permit (#2081(a)-16-053-V), and is an authorized individual on the CDFW Scientific Collecting Permit (SC-7617). Responsibilities: Project manager, report preparation.

Jeffery Little, Vice President, Sycamore Environmental. Over 24 years experience with preparation of NES, BA, and NEPA/CEQA compliance documents, impact analysis, agency formal and informal consultations and permitting. Project management, conducts special-status species surveys, jurisdictional delineations, and prepares mitigation and monitoring plans. CAD/ GIS Manager responsible for data collection, map creation, impact analyses, and report preparation. He holds a California Department of Fish and Wildlife Rare, Threatened and Endangered Plant Voucher Collecting Permit (2081(a)-14-078-V), and is an authorized individual on the CDFW Scientific Collecting Permit (SC-7617).

Responsibilities: Principal-in-Charge, QA/QC

Aramis Respass, GIS Analyst/ CAD Operator. Over 20 years experience in drafting and spatial analysis using AutoCAD map and ArcGIS for public and private projects. Prepares figures for biological and permitting documents such as project location maps, biological resource maps, wetlands/waters delineation maps, impact analysis maps, and other supporting graphics. Primary experience evolved from surveying and civil engineering practices to advanced GPS/GIS technology.

Responsibilities: Figure preparation and spatial analysis.

APPENDIX A

Plant and Wildlife Species Observed

Plant Species Observed. Taxonomy follows Baldwin et al. 2012.

Family	Scientific Name	Common Name	N/I ¹	CAL-IPC ²
GYMNOSPERMS				
EUDICOTS				
Asteraceae	<i>Baccharis pilularis</i>	Coyote brush	N	
	<i>Centaurea solstitialis</i>	Yellow star-thistle	I	High
	<i>Carduus pycnocephalus</i> ssp. <i>pycnocephalus</i>	Italian thistle	I	Moderate
	<i>Cirsium vulgare</i>	Bull thistle	I	Moderate
	<i>Lactuca serriola</i>	Prickly lettuce	I	
	<i>Leontodon saxatilis</i>	Hairy hawkbit	I	
	<i>Tragopogon dubius</i>	Yellow salsify	I	
Euphorbiaceae	<i>Croton setigerus</i>	Turkey-mullein	N	
Fabaceae	<i>Acmispon americanus</i> var. <i>americanus</i>	Deervetch	N	
	<i>Trifolium hirtum</i>	Rose clover	I	Limited
	<i>Trifolium glomeratum</i>	Clustered clover	I	
Gentianaceae	<i>Zeltnera muehlenbergii</i>	Monterey centaury	N	
Geraniaceae	<i>Erodium botrys</i>	Storksbill, filaree	I	
Rosaceae	<i>Rubus armeniacus</i>	Himalayan blackberry	I	High
	<i>Galium aparine</i>	Goose grass	N	
Scrophulariaceae	<i>Verbascum thapsus</i>	Woolly mullein	I	Limited
MONOCOTS				
Poaceae	<i>Aira caryophyllea</i>	Silver hair grass	I	
	<i>Avena barbata</i>	Slender wild oat	I	Moderate
	<i>Cynodon dactylon</i>	Bermuda grass	I	Moderate
	<i>Cynosurus echinatus</i>	Bristly dogtail grass	I	Moderate
	<i>Hordeum murinum</i> ssp. <i>leporinum</i>	Hare barley	I	Moderate
Themidaceae	<i>Brodiaea elegans</i> ssp. <i>elegans</i>	Harvest brodiaea	N	

¹ N = Native to CA; I = Introduced.

² Negative ecological impact according to the California Invasive Plant Council (Cal-IPC 2006).

Wildlife Species Observed

COMMON NAME	SCIENTIFIC NAME
BIRDS	
Spotted towhee	<i>Pipilo maculatus</i>
Lesser goldfinch	<i>Spinus psaltria</i>
Tree swallow	<i>Tachycineta bicolor</i>
Turkey vulture	<i>Cathartes aura</i>

[This page intentionally left blank]



United States Department of the Interior



FISH AND WILDLIFE SERVICE
Sacramento Fish And Wildlife Office
Federal Building
2800 Cottage Way, Room W-2605
Sacramento, CA 95825-1846
Phone: (916) 414-6600 Fax: (916) 414-6713

In Reply Refer To:

June 26, 2017

Consultation Code: 08ESMF00-2017-SLI-2438

Event Code: 08ESMF00-2017-E-06633

Project Name: Gold Hill Wireless Telecommunication Facility

Subject: List of threatened and endangered species that may occur in your proposed project location, and/or may be affected by your proposed project

To Whom It May Concern:

The enclosed species list identifies threatened, endangered, proposed and candidate species, as well as proposed and final designated critical habitat, under the jurisdiction of the U.S. Fish and Wildlife Service (Service) that may occur within the boundary of your proposed project and/or may be affected by your proposed project. The species list fulfills the requirements of the Service under section 7(c) of the Endangered Species Act (Act) of 1973, as amended (16 U.S.C. 1531 et seq.).

Please follow the link below to see if your proposed project has the potential to affect other species or their habitats under the jurisdiction of the National Marine Fisheries Service:

http://www.nwr.noaa.gov/protected_species/species_list/species_lists.html

New information based on updated surveys, changes in the abundance and distribution of species, changed habitat conditions, or other factors could change this list. Please feel free to contact us if you need more current information or assistance regarding the potential impacts to federally proposed, listed, and candidate species and federally designated and proposed critical habitat. Please note that under 50 CFR 402.12(e) of the regulations implementing section 7 of the Act, the accuracy of this species list should be verified after 90 days. This verification can be completed formally or informally as desired. The Service recommends that verification be completed by visiting the ECOS-IPaC website at regular intervals during project planning and implementation for updates to species lists and information. An updated list may be requested through the ECOS-IPaC system by completing the same process used to receive the enclosed list.

The purpose of the Act is to provide a means whereby threatened and endangered species and the ecosystems upon which they depend may be conserved. Under sections 7(a)(1) and 7(a)(2) of the Act and its implementing regulations (50 CFR 402 et seq.), Federal agencies are required to

utilize their authorities to carry out programs for the conservation of threatened and endangered species and to determine whether projects may affect threatened and endangered species and/or designated critical habitat.

A Biological Assessment is required for construction projects (or other undertakings having similar physical impacts) that are major Federal actions significantly affecting the quality of the human environment as defined in the National Environmental Policy Act (42 U.S.C. 4332(2) (c)). For projects other than major construction activities, the Service suggests that a biological evaluation similar to a Biological Assessment be prepared to determine whether the project may affect listed or proposed species and/or designated or proposed critical habitat. Recommended contents of a Biological Assessment are described at 50 CFR 402.12.

If a Federal agency determines, based on the Biological Assessment or biological evaluation, that listed species and/or designated critical habitat may be affected by the proposed project, the agency is required to consult with the Service pursuant to 50 CFR 402. In addition, the Service recommends that candidate species, proposed species and proposed critical habitat be addressed within the consultation. More information on the regulations and procedures for section 7 consultation, including the role of permit or license applicants, can be found in the "Endangered Species Consultation Handbook" at:

<http://www.fws.gov/endangered/esa-library/pdf/TOC-GLOS.PDF>

Please be aware that bald and golden eagles are protected under the Bald and Golden Eagle Protection Act (16 U.S.C. 668 et seq.), and projects affecting these species may require development of an eagle conservation plan (http://www.fws.gov/windenergy/eagle_guidance.html). Additionally, wind energy projects should follow the wind energy guidelines (<http://www.fws.gov/windenergy/>) for minimizing impacts to migratory birds and bats.

Guidance for minimizing impacts to migratory birds for projects including communications towers (e.g., cellular, digital television, radio, and emergency broadcast) can be found at: <http://www.fws.gov/migratorybirds/CurrentBirdIssues/Hazards/towers/towers.htm>; <http://www.towerkill.com>; and <http://www.fws.gov/migratorybirds/CurrentBirdIssues/Hazards/towers/comtow.html>.

We appreciate your concern for threatened and endangered species. The Service encourages Federal agencies to include conservation of threatened and endangered species into their project planning to further the purposes of the Act. Please include the Consultation Tracking Number in the header of this letter with any request for consultation or correspondence about your project that you submit to our office.

Attachment(s):

- Official Species List

Official Species List

This list is provided pursuant to Section 7 of the Endangered Species Act, and fulfills the requirement for Federal agencies to "request of the Secretary of the Interior information whether any species which is listed or proposed to be listed may be present in the area of a proposed action".

This species list is provided by:

Sacramento Fish And Wildlife Office

Federal Building

2800 Cottage Way, Room W-2605

Sacramento, CA 95825-1846

(916) 414-6600

Project Summary

Consultation Code: 08ESMF00-2017-SLI-2438

Event Code: 08ESMF00-2017-E-06633

Project Name: Gold Hill Wireless Telecommunication Facility

Project Type: ** OTHER **

Project Description: Installation of wireless telecommunication facility in northeastern El Dorado County.

Project Location:

Approximate location of the project can be viewed in Google Maps:

<https://www.google.com/maps/place/38.802414294515486N120.93724781487958W>



Counties: El Dorado, CA

Endangered Species Act Species

There is a total of 6 threatened, endangered, or candidate species on your species list. Species on this list should be considered in an effects analysis for your project and could include species that exist in another geographic area. For example, certain fish may appear on the species list because a project could affect downstream species. See the "Critical habitats" section below for those critical habitats that lie wholly or partially within your project area. Please contact the designated FWS office if you have questions.

Amphibians

NAME	STATUS
California Red-legged Frog (<i>Rana draytonii</i>) There is a final critical habitat designated for this species. Your location is outside the designated critical habitat. Species profile: https://ecos.fws.gov/ecp/species/2891	Threatened

Fishes

NAME	STATUS
Delta Smelt (<i>Hypomesus transpacificus</i>) There is a final critical habitat designated for this species. Your location is outside the designated critical habitat. Species profile: https://ecos.fws.gov/ecp/species/321	Threatened
Steelhead (<i>Oncorhynchus (=Salmo) mykiss</i>) Population: Northern California DPS There is a final critical habitat designated for this species. Your location is outside the designated critical habitat. Species profile: https://ecos.fws.gov/ecp/species/1007	Threatened

Flowering Plants

NAME	STATUS
Layne's Butterweed (<i>Senecio layneae</i>) No critical habitat has been designated for this species. Species profile: https://ecos.fws.gov/ecp/species/4062	Threatened
Pine Hill Ceanothus (<i>Ceanothus roderickii</i>) No critical habitat has been designated for this species. Species profile: https://ecos.fws.gov/ecp/species/3293	Endangered
Stebbins' Morning-glory (<i>Calystegia stebbinsii</i>) No critical habitat has been designated for this species. Species profile: https://ecos.fws.gov/ecp/species/3991	Endangered

Critical habitats

There are no critical habitats within your project area.

[This page intentionally left blank]



Selected Elements by Scientific Name

California Department of Fish and Wildlife

California Natural Diversity Database



Query Criteria: Quad (Auburn (3812181) OR Greenwood (3812088) OR Georgetown (3812087) OR Pilot Hill (3812171) OR Coloma (3812078) OR Garden Valley (3812077) OR Clarksville (3812161) OR Shingle Springs (3812068) OR Placerville (3812067))

Species	Element Code	Federal Status	State Status	Global Rank	State Rank	Rare Plant Rank/CDFW SSC or FP
<i>Accipiter gentilis</i> northern goshawk	ABNKC12060	None	None	G5	S3	SSC
<i>Agelaius tricolor</i> tricolored blackbird	ABPBXB0020	None	Candidate Endangered	G2G3	S1S2	SSC
<i>Allium jepsonii</i> Jepson's onion	PMLIL022V0	None	None	G2	S2	1B.2
<i>Ammonitella yatesii</i> tight coin (=Yates' snail)	IMGASB0010	None	None	G1	S1	
<i>Andrena blennospermatis</i> Blennosperma vernal pool andrenid bee	IIHYM35030	None	None	G2	S2	
<i>Andrena subapasta</i> An andrenid bee	IIHYM35210	None	None	G1G2	S1S2	
<i>Aquila chrysaetos</i> golden eagle	ABNKC22010	None	None	G5	S3	FP
<i>Arctostaphylos nissenana</i> Nissenan manzanita	PDERI040V0	None	None	G1	S1	1B.2
<i>Ardea alba</i> great egret	ABNGA04040	None	None	G5	S4	
<i>Ardea herodias</i> great blue heron	ABNGA04010	None	None	G5	S4	
<i>Athene cunicularia</i> burrowing owl	ABNSB10010	None	None	G4	S3	SSC
<i>Balsamorhiza macrolepis</i> big-scale balsamroot	PDAST11061	None	None	G2	S2	1B.2
<i>Banksula californica</i> Alabaster Cave harvestman	ILARA14020	None	None	GH	SH	
<i>Banksula galilei</i> Galile's cave harvestman	ILARA14040	None	None	G1	S1	
<i>Bombus morrisoni</i> Morrison bumble bee	IIHYM24460	None	None	G4G5	S1S2	
<i>Bombus occidentalis</i> western bumble bee	IIHYM24250	None	None	G2G3	S1	
<i>Branchinecta lynchi</i> vernal pool fairy shrimp	ICBRA03030	Threatened	None	G3	S3	
<i>Calystegia stebbinsii</i> Stebbins' morning-glory	PDCON040H0	Endangered	Endangered	G1	S1	1B.1
<i>Calystegia vanzuukiae</i> Van Zuurk's morning-glory	PDCON040Q0	None	None	G2Q	S2	1B.3



Selected Elements by Scientific Name
California Department of Fish and Wildlife
California Natural Diversity Database



Species	Element Code	Federal Status	State Status	Global Rank	State Rank	Rare Plant Rank/CDFW SSC or FP
<i>Carex cyrtostachya</i> Sierra arching sedge	PMCYP03M00	None	None	G2	S2	1B.2
<i>Carex xerophila</i> chaparral sedge	PMCYP03M60	None	None	G2	S2	1B.2
<i>Ceanothus roderickii</i> Pine Hill ceanothus	PDRHA04190	Endangered	Rare	G1	S1	1B.1
Central Valley Drainage Hardhead/Squawfish Stream Central Valley Drainage Hardhead/Squawfish Stream	CARA2443CA	None	None	GNR	SNR	
<i>Chlorogalum grandiflorum</i> Red Hills soaproot	PMLIL0G020	None	None	G2	S2	1B.2
<i>Clarkia biloba ssp. brandegeae</i> Brandegee's clarkia	PDONA05053	None	None	G4G5T4	S4	4.2
<i>Corynorhinus townsendii</i> Townsend's big-eared bat	AMACC08010	None	None	G3G4	S2	SSC
<i>Cosumnoperla hypocrena</i> Cosumnes stripetail	IIPLE23020	None	None	G2	S2	
<i>Crocانthemum suffrutescens</i> Bisbee Peak rush-rose	PDCIS020F0	None	None	G2Q	S2	3.2
<i>Desmocerus californicus dimorphus</i> valley elderberry longhorn beetle	IICOL48011	Threatened	None	G3T2	S2	
<i>Elanus leucurus</i> white-tailed kite	ABNKC06010	None	None	G5	S3S4	FP
<i>Emys marmorata</i> western pond turtle	ARAAD02030	None	None	G3G4	S3	SSC
<i>Falco peregrinus anatum</i> American peregrine falcon	ABNKD06071	Delisted	Delisted	G4T4	S3S4	FP
<i>Fremontodendron decumbens</i> Pine Hill flannelbush	PDSTE03030	Endangered	Rare	G1	S1	1B.2
<i>Fritillaria eastwoodiae</i> Butte County fritillary	PMLIL0V060	None	None	G3Q	S3	3.2
<i>Galium californicum ssp. sierrae</i> El Dorado bedstraw	PDRUB0N0E7	Endangered	Rare	G5T1	S1	1B.2
<i>Haliaeetus leucocephalus</i> bald eagle	ABNKC10010	Delisted	Endangered	G5	S3	FP
<i>Horkelia parryi</i> Parry's horkelia	PDROS0W0C0	None	None	G2	S2	1B.2
<i>Hydrochara rickseckeri</i> Ricksecker's water scavenger beetle	IICOL5V010	None	None	G2?	S2?	
<i>Lasionycteris noctivagans</i> silver-haired bat	AMACC02010	None	None	G5	S3S4	
<i>Lathyrus sulphureus var. argillaceus</i> dubious pea	PDFAB25101	None	None	G5T1T2	S1S2	3



Selected Elements by Scientific Name
California Department of Fish and Wildlife
California Natural Diversity Database



Species	Element Code	Federal Status	State Status	Global Rank	State Rank	Rare Plant Rank/CDFW SSC or FP
<i>Myotis yumanensis</i> Yuma myotis	AMACC01020	None	None	G5	S4	
<i>Oncorhynchus mykiss irideus</i> steelhead - Central Valley DPS	AFCHA0209K	Threatened	None	G5T2Q	S2	
<i>Packera layneae</i> Layne's ragwort	PDAST8H1V0	Threatened	Rare	G2	S2	1B.2
<i>Pekania pennanti</i> fisher - West Coast DPS	AMAJF01021	Proposed Threatened	Candidate Threatened	G5T2T3Q	S2S3	SSC
<i>Phrynosoma blainvillii</i> coast horned lizard	ARACF12100	None	None	G3G4	S3S4	SSC
<i>Rana boylei</i> foothill yellow-legged frog	AAABH01050	None	None	G3	S3	SSC
<i>Rana draytonii</i> California red-legged frog	AAABH01022	Threatened	None	G2G3	S2S3	SSC
<i>Riparia riparia</i> bank swallow	ABPAU08010	None	Threatened	G5	S2	
<i>Sagittaria sanfordii</i> Sanford's arrowhead	PMALI040Q0	None	None	G3	S3	1B.2
<i>Viburnum ellipticum</i> oval-leaved viburnum	PDCPR07080	None	None	G4G5	S3?	2B.3
<i>Wyethia reticulata</i> El Dorado County mule ears	PDAST9X0D0	None	None	G2	S2	1B.2

Record Count: 51

[This page intentionally left blank]

Plant List

Inventory of Rare and Endangered Plants

31 matches found. Click on scientific name for details

Search Criteria

California Rare Plant Rank is one of [1A, 1B, 2A, 2B, 3, 4], Found in Quads 3812181, 3812088, 3812087, 3812171, 3812078, 3812077, 3812161 3812068 and 3812067;

[Modify Search Criteria](#)
[Export to Excel](#)
[Modify Columns](#)
[Modify Sort](#)
[Display Photos](#)

Scientific Name	Common Name	Family	Lifeform	Blooming Period	CA Rare Plant Rank	State Listing Status	Federal Listing Status
Allium jepsonii	Jepson's onion	Alliaceae	perennial bulbiferous herb	Apr-Aug	1B.2		
Allium sanbornii var. congdonii	Congdon's onion	Alliaceae	perennial bulbiferous herb	Apr-Jul	4.3		
Allium sanbornii var. sanbornii	Sanborn's onion	Alliaceae	perennial bulbiferous herb	May-Sep	4.2		
Arctostaphylos mewukka ssp. truei	True's manzanita	Ericaceae	perennial evergreen shrub	Feb-Jul	4.2		
Arctostaphylos nissenana	Nissenan manzanita	Ericaceae	perennial evergreen shrub	Feb-Mar	1B.2		
Balsamorhiza macrolepis	big-scale balsamroot	Asteraceae	perennial herb	Mar-Jun	1B.2		
Calandrinia breweri	Brewer's calandrinia	Montiaceae	annual herb	(Jan)Mar-Jun	4.2		
Calystegia stebbinsii	Stebbins' morning-glory	Convolvulaceae	perennial rhizomatous herb	Apr-Jul	1B.1	CE	FE
Calystegia vanzuukiae	Van Zuurk's morning-glory	Convolvulaceae	perennial rhizomatous herb	May-Aug	1B.3		
Carex cyrtostachya	Sierra arching sedge	Cyperaceae	perennial herb	May-Aug	1B.2		
Carex xerophila	chaparral sedge	Cyperaceae	perennial herb	Mar-Jun	1B.2		
Ceanothus fresnensis	Fresno ceanothus	Rhamnaceae	perennial evergreen shrub	May-Jul	4.3		
Ceanothus roderickii	Pine Hill ceanothus	Rhamnaceae	perennial evergreen shrub	Apr-Jun	1B.1	CR	FE
Chlorogalum grandiflorum	Red Hills soaproot	Agavaceae	perennial bulbiferous herb	May-Jun	1B.2		
Clarkia biloba ssp. brandegeae	Brandegee's clarkia	Onagraceae	annual herb	May-Jul	4.2		
Claytonia parviflora ssp. grandiflora	streambank spring beauty	Montiaceae	annual herb	Feb-May	4.2		
Cordylanthus tenuis ssp. brunneus	serpentine bird's-beak	Orobanchaceae	annual herb (hemiparasitic)	Jul-Aug	4.3		
	Bisbee Peak	Cistaceae	perennial evergreen	Apr-Aug	3.2		

<u>Crocanthemum suffrutescens</u>	rush-rose		shrub				
<u>Delphinium hansenii ssp. ewaianum</u>	Ewan's larkspur	Ranunculaceae	perennial herb	Mar-May	4.2		
<u>Eriogonum tripodum</u>	tripod buckwheat	Polygonaceae	perennial deciduous shrub	May-Jul	4.2		
<u>Eriophyllum jepsonii</u>	Jepson's woolly sunflower	Asteraceae	perennial herb	Apr-Jun	4.3		
<u>Fremontodendron decumbens</u>	Pine Hill flannelbush	Malvaceae	perennial evergreen shrub	Apr-Jul	1B.2	CR	FE
<u>Fritillaria eastwoodiae</u>	Butte County fritillary	Liliaceae	perennial bulbiferous herb	Mar-Jun	3.2		
<u>Galium californicum ssp. sierrae</u>	El Dorado bedstraw	Rubiaceae	perennial herb	May-Jun	1B.2	CR	FE
<u>Horkelia parryi</u>	Parry's horkelia	Rosaceae	perennial herb	Apr-Sep	1B.2		
<u>Lathyrus sulphureus var. argillaceus</u>	dubious pea	Fabaceae	perennial herb	Apr-May	3		
<u>Lilium humboldtii ssp. humboldtii</u>	Humboldt lily	Liliaceae	perennial bulbiferous herb	May-Jul(Aug)	4.2		
<u>Packera layneae</u>	Layne's ragwort	Asteraceae	perennial herb	Apr-Aug	1B.2	CR	FT
<u>Sagittaria sanfordii</u>	Sanford's arrowhead	Alismataceae	perennial rhizomatous herb (emergent)	May-Oct(Nov)	1B.2		
<u>Viburnum ellipticum</u>	oval-leaved viburnum	Adoxaceae	perennial deciduous shrub	May-Jun	2B.3		
<u>Wyethia reticulata</u>	El Dorado County mule ears	Asteraceae	perennial herb	Apr-Aug	1B.2		

Suggested Citation

California Native Plant Society, Rare Plant Program. 2017. Inventory of Rare and Endangered Plants of California (online edition, v8-03 0.39). Website <http://www.rareplants.cnps.org> [accessed 26 June 2017].

Search the Inventory

[Simple Search](#)

[Advanced Search](#)

[Glossary](#)

Information

[About the Inventory](#)

[About the Rare Plant Program](#)

[CNPS Home Page](#)

[About CNPS](#)

[Join CNPS](#)

Contributors

[The Calflora Database](#)

[The California Lichen Society](#)

APPENDIX D

Photographs



Photo 1. View facing northwest towards gravel road from the south end of the BSA. 28 June 2017.



Photo 2. View facing southeast towards ruderal community and landscaped garden on the south end of BSA. 28 June 2017.

[This page intentionally left blank]



Photo 3. View facing east towards gravel road from the north end of the BSA.



Photo 4. View facing north towards the existing gravel road from the center of the BSA. 28 June 2017.

[This page intentionally left blank]



Photo 5: View facing south towards ruderal community and gravel road from center of the BSA. 28 June 2017.



Photo 6. View facing southeast towards ruderal community and existing structures from the south end of the proposed access road. Existing gravel road on the right. 28 June 2017.

[This page intentionally left blank]